

---

This is a reproduction of a library book that was digitized by Google as part of an ongoing effort to preserve the information in books and make it universally accessible.

Google™ books

<https://books.google.com>

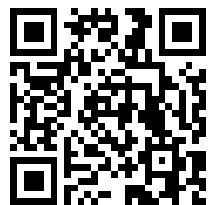

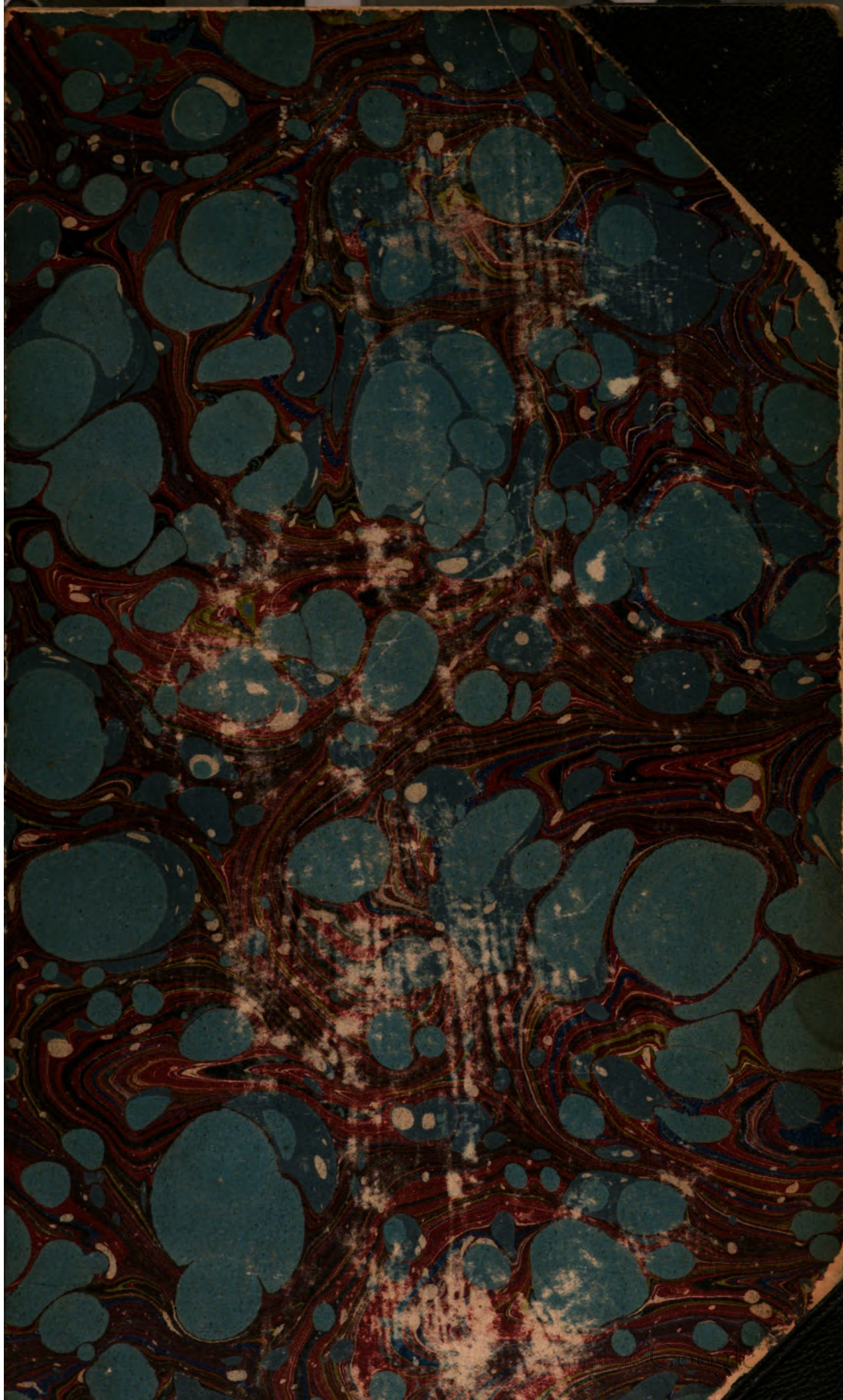

**THE  
PENNSYLVANIA  
STATE UNIVERSITY  
LIBRARY**



2302





**THE  
PENNSYLVANIA  
STATE UNIVERSITY  
LIBRARY**



2302













THE  
AMERICAN  
ANNUAL CYCLOPÆDIA  
AND  
REGISTER OF IMPORTANT EVENTS  
OF THE YEAR  
1862.

EMBRACING POLITICAL, CIVIL, MILITARY, AND SOCIAL AFFAIRS; PUBLIC DOCUMENTS; BIOGRAPHY, STATISTICS, COMMERCE, FINANCE, LITERATURE, SCIENCE, AGRICULTURE AND MECHANICAL INDUSTRY.

VOLUME II.

NEW YORK:  
D. APPLETON & COMPANY, 443 & 445 BROADWAY.

M.DCCC.LXIII.

C 31  
Am 35  
V. 2

ENTERED, according to Act of Congress, in the year 1868, by  
D. APPLETON & COMPANY,  
In the Clerk's Office of the District Court of the United States for the Southern District  
of New York.

**THE PENNSYLVANIA STATE  
UNIVERSITY LIBRARY**

## P R E F A C E .

---

**THE** favorable reception given to the volume of this work for the preceding year has induced the publishers to make special efforts in the preparation of this one. It is their aim to make an Annual Supplement not only to the New American Cyclopædia, but to all others, which shall embrace contemporaneous events, and the progress attained in the various branches of knowledge. Such a work is addressed to all classes of readers, since it includes in its contents whatever transpires in political, military, civil, and social affairs, commerce, finance, literature, science, agriculture, art, and mechanical industry.

The year 1862 will probably be looked upon as the most important in a period of great events. It witnessed the struggles of great armies ; the numerous battles and ceaseless skirmishes in the United States ; the expedition against Mexico ; the disgraceful flight of King Otho of Greece ; the unfortunate conflict at Aspromonte, in Italy ; the enkindling of the Polish revolution ; the French war in Cochin China ; the recognition in Russia of the rights of man, by the approaching emancipation of the serfs ; the Tae-ping rebellion in China ; and, not least, the distress in Lancashire, and the stoppage of the looms of Lyons. Of scarcely less note were the naval conflict below New Orleans ; the contest between the Monitor and Merrimac, and the destructive exploits of the Alabama. Among the peaceful events were the debates and proceedings in the Federal Congress on confiscation and emancipation ; the triumph of anti-slavery views in the Government of the United States, and its measures for emancipation ; the silent revolution shown by the ballot-box ; and the measures of the seceded States to secure their independent organization.

The relation of these events, especially those of a military character, it is hoped, will be found truthful and just. It is a detailed statement, day by day and step by step, of the movements of the armies, the objects of those movements, and their consequences. It has been prepared chiefly from official papers, and is accompanied with corresponding maps and plans of battles. Important documents and reports are also given.

The details of the internal affairs of the country embrace the organizations of the armies North and South, their officers, and the number and condition of the troops; the important measures of the Federal and Confederate Congresses; the acts and resolutions of State Legislatures and State political organizations; the votes of the citizens at the elections; the messages of the Presidents of the United and seceded States; the orders and instructions of cabinet officers and of commanding generals; the commercial regulations relating to trade with ports of the Southern States; the loans, taxes, and currency measures and debts of the Federal and Confederate Governments; their intercourse with foreign nations, and the difficult questions that occurred; the enforcement of martial law, and the exchange of prisoners; thus comprising all important occurrences in the history of the nation.

The interesting events relating to foreign nations, as above stated, are presented with such fulness as to enable the reader to comprehend their causes, their influence upon the welfare of the people, and their probable results.

The progress of mechanical industry is shown in the active construction of iron-clad vessels; in the display at the British Industrial Exhibition; in the many interesting inventions presented at the Patent Office; in the repairs of the steamer Great Eastern, and some other achievements.

The developments in natural science have not been overlooked. In some branches these have been fully brought up, and notice has been taken of various questions raised among scientific men, and the views presented in their discussions.

The continued prosperity of the commerce of the country, and its kindred pursuits, since the previous year, and the surprising resources of the people, as shown in the vast financial operations of the Government, forming a portion of current history of more than usual interest, are explained with ample details.

The geographical explorations were active in all quarters, and those of archæology produced some surprising results. The record of literature was hardly less important than in former years, although the number of works issued was somewhat reduced.

The present condition of the principal religious denominations of the United States is so presented as to show their branches, membership, numbers, views on civil affairs, and the spread of their distinctive opinions among the nations of the earth.

The mortality of the year was unusually large, and the number of distinguished men who closed their career was far greater than usual. Their services have been fully recognized.

THE  
ANNUAL CYCLOPÆDIA.

---

A

**AFRICA**, one of the six grand divisions of the earth's surface, comprises the southwest-ern portion of the eastern continent. Its political divisions are, on the north, the Empire of Morocco; the French province of Algeria; the pashaliks of Tunis, Tripoli, and Barca, and the oasis of Fezzan, dependencies of the Turkish empire; Egypt, a viceroyalty of the Turkish empire, though in a state of *quasi*-independ-ency. On the east, Nubia and Kordofan, de-pendencies of Egypt; Abyssinia, a collection of petty states under savage chieftains, a consid-erable number of which have recently become subject to the sway of the bold and capable Theodore, the chief of Amhara, who has taken the title of "King of the Kings of Ethiopia;" the countries bordering on the gulf of Aden and the Indian Ocean, and stretching southwestward for more than a thousand miles; these are in-habited by tribes of savages known by the names of Somauli, Wakuafi, Wanika, Galla, &c. &c. The names of the principal countries are: Adel, Ajan, Berbera, Zanguebar (which is a collection of several states), and Mozambique, the coast of which is held by the Portuguese. At different points of this long stretch of coast the Arabs have established themselves, and have reduced the native tribes to subjection, though others, as the Gallas, defy their author-ity and maintain an ascendancy over the tribes of the interior. Of these interior tribes or their country little is known, the many attempts made by missionaries and explorers to pene-trate to any considerable distance from the coast, having been, in most instances, repulsed by the savages, often with the loss of the lives of the explorers. On the Mozambique coast the Portuguese have maintained for many years an extended commerce, mainly in ivory and slaves. Dr. Livingstone has penetrated into the interior through this country, ascending the

Zambezi to the Victoria Falls, and exploring a portion of the course of the Shire and the Rov-uma as well as the lakes Nyassa and Nyanja. East of Mozambique, and separated from it by the Mozambique channel, is the great and pop-ulous island of Madagascar.

South Africa is composed of several states, part of them British colonies, and part in some sense dependencies of these. The Cape Colony is the oldest of these, and occupies the southern portion of the continent; above it, on the S. E., are Caffraria, Natal, and the Zulu country; and lying west of these and separated from them by the Kalamba mountains, the Orange river, and Transvaal Republics, composed mostly of Dutch settlers and their Hottentot or Bechu-ana dependents. On the west coast, north of the Orange river, and extending about 300 miles into the interior, is the Hottentot coun-try, and lying between this and the Transvaal Republics, the land of the Bechuanas.

North of the Hottentot country, stretching northward for more than 1,500 miles, is the region long known as Lower Guinea, but really composed of numerous chieftaincies and some Portuguese colonies. These chieftaincies, be-ginning with the most southern, are Cimbebas and the country of the Damaras, Benguela, An-gola a Portuguese colony, Congo, Loango, the region of the Gabûn, country of the Calbongas, and Biafra. Between this and the eastern coast described above, lies a vast tract, varying in width from ten to twenty-eight degrees of longitude, and extending from nearly ten de-grees above to sixteen degrees below the equa-tor, almost wholly unexplored by Europeans. Along the eastern portion of it Dr. Livingstone has made some discoveries, but much of this has only been penetrated by him and his ad-venturous coadjutors.

From the gulf of Biafra the continent turns

sharply westward, and the coast line of Upper Guinea faces the south. This region, long known as the slave coast, is occupied by several native states, the largest being the Kingdom of Dahomey, the king of which has attained an evil notoriety by the vast number of human sacrifices immolated on his altars. North of this, and stretching in a belt of variable width across the continent to the confines of Nubia and Kordofan, is that region known formerly as Soudan and Nigritia, composed of numerous and constantly changing states, part of them Mohammedan and part pagan. The most important of these, beginning in the east, are Darfur, Waday, Bergoo, Kanem, Bornou, Adamawa, Houssa, Timbuctoo, Yoruba, and Bambarra.

Where the western coast of Africa begins again to turn-northward, is the little Republic of Liberia, and northwest of it the British colony of Sierra Leone, both settled in great part by free negroes, either from the United States or Great Britain, or recaptured Africans taken from slave ships, or, as in the case of a portion of the inhabitants of Liberia, native tribes who have become civilized. Lying between this and the Great Desert is the country of Senegambia named from its two great rivers, inhabited by several tribes of negroes and mixed races. France has a colony, St. Louis, at the mouth of the Senegal, and England a settlement, Bathurst, at the mouth of the Gambia. Between this country and the Empire of Morocco, and extending eastward to the confines of Egypt and Nubia, with but here and there a fertile oasis and grove of palms amid its vast wastes of sand, stretches the Great Desert of Sahara. Its oases are inhabited by tribes of Arab or half Arab origin, the Tuaregs, the Tibboos, &c., and its deserts are traversed by caravans and companies of Arab Bedouins, the exact counterparts of their brethren of Arabia.

In another place (*see* GEOGRAPHICAL EXPLORATIONS) will be found the results obtained, during 1862, by the numerous exploring parties who have penetrated into the unknown interior of this vast continent-peninsula. In the present article it is proposed to notice briefly a few of the important political events of the past year in the countries best known to the civilized world.

In Morocco the treaty of peace with Spain, of April 26, 1860 (*see* NEW AMERICAN CYCLOPEDIA, vol. xi, art. MOROCCO), by which the Emperor Sidi Mohammed agreed to pay to Spain an indemnity of 20,000,000 piastres (about \$4,000,000, and to cede a district of territory around Melilla, valued at \$37,500,000, had remained unfulfilled up to the summer of 1861. The indemnity had not been paid, and the Kabyles, or inhabitants of Rif, refused to obey the mandate of the emperor, and surrender their lands; and throughout Morocco, there were indications of insurrection, which the emperor lacked the power to suppress. Spain meantime held the important city of Tetuan in which she was authorized to con-

tinue a garrison till the fulfilment of the treaty, and made preparations for its permanent occupation. Unwilling to relinquish this important post, Sidi Mohammed sent his brother Muley-el-Abbas, to treat with the Spanish Government for more favorable terms. He succeeded in negotiating a new treaty, in which the payment of three million *douros* within 5 months is guaranteed, and the payment of the remainder of the indemnity made a lien on the customs receipts, for the prompt payment of which the Queen of Spain is authorized to appoint an agent to receive a portion of the duties at each of the five ports of the empire. The Spaniards are to evacuate Tetuan when the first instalment of the indemnity is paid, the territory ceded by the former treaty being placed under their control prior to the evacuation. The Spanish missionaries are to be allowed to found a Mission House at Tetuan, and to be protected in their persons, their asylums, and the exercise of their worship throughout the empire. In January, 1862, a convention was concluded between the Sultan of Morocco and the British Government, by virtue of which the sultan obtained a loan of about half a million pounds sterling, at 5 per cent., at a discount of 17 per cent., reimbursable from the half of the revenue of the ports, at the rate of £38,000 per annum, to be collected by English officers resident at those ports. The amount of this loan was to be paid over to Spain as indemnity. This gives the British Government an influence in Morocco, which, with her possession of Gibraltar, enables her to hold the keys of the Mediterranean.

In Egypt, Mohammed Said Pasha, viceroy since 1854, and the wisest and most judicious ruler of Egypt in modern times, died in January, 1863. He had released the fellahs or cultivators of the soil, from the condition of serfs in which he found them, abolished the system of monopolies by which the government was the sole purchaser and vender of Egyptian products, and allowed the farmer to sell his crops in any market he chose; substituted a tax of 8 per cent. of the income, payable in money, for the old tax of one tenth, payable in kind, abrogated all internal excises, bestowed on the fellah the liberty of changing his residence at will, and allowed the judges of the provinces and districts to be elected by the people, as a measure of judicial reform. He had also made great reforms in the conscription, organization, and discipline of the army. The finances, which, on his accession to the viceroyalty, were in a deplorable state, are now in a better condition than those of any other oriental country. The debt is only 82 millions of dollars, the annual receipts about 8 millions of dollars beyond the ordinary expenditure, and the bonds of the government at par, with 8 per cent. interest, while the ordinary and legal interest of the country is 10 per cent.

There is undoubtedly a dark side to this picture. Bribery, corruption, and speculation,

which seem inseparable from all oriental governments, existed here also; and contractors were continually robbing the government. The worst feature in the administration of Said Pasha was his neglect and partial suppression of the schools of the vicerealty, established with so much labor by his grandfather Mehemet Ali. His successor, Ismail Pasha, who is a warm advocate of education, will unquestionably remedy this great defect of his administration. In 1862 Said Pasha was obliged to resort to another loan of 8 millions of dollars, which was negotiated at 82½ per cent. for 7 per cent. thirty years' bonds. The present debt of the vicerealty is \$33,250,000, of which about \$17,000,000 is for bonds issued to the Company of the Canal of Suez. The imports of the country for 1861 were \$18,396,308, and its exports \$17,155,491, from the port of Alexandria alone, to which is to be added a small sum from other ports. In October, 1861, Egypt was visited by a terrible flood; the Nile breaking through the levees or dikes, which confined it in Upper Egypt, laid almost the whole of Lower Egypt under water, destroying the crops of maize and millet, and greatly injuring the cotton and sugar crops. The railroads and telegraph lines were also undermined and torn up, and a vast number of dwellings and animals destroyed. To the great joy of the people the flood subsided rapidly, and despite its destructiveness of property, greatly enhanced the yield and value of the crop of 1862.

The ship canal, intended to unite the Mediterranean and the Red Sea, by cutting through the Isthmus of Suez from Port Said to Suez, projected by M. Ferdinand Lesseps, and carried forward by the French, Egyptian, and Turkish Governments, is approaching completion. At the annual meeting of the canal company in May, 1862, M. Lesseps stated that it would undoubtedly be opened to canal-boat navigation by May, 1863, and to ships by the spring of 1866. The work has been one of great difficulty; it was found necessary to construct a fresh-water canal to connect with the Nile, as well as the ship canal, and to build piers, jetties, and breakwaters to protect shipping entering the canal from either sea; and in order to secure the opening of one of the ancient canals, the company were under the necessity of purchasing the entire estate of Waday, the property of El-Hamy Pasha, at a cost of about \$400,000. The total expenditure to May, 1862, had been about \$42,000,000, and nearly \$30,000,000 would probably be required to complete it. Twenty-six thousand men were employed on the work, and M. Lesseps hoped to have 85,000 to 40,000 employed during the next year.

In Abyssinia, Theodore, "King of the Kings of Ethiopia" (see *NEW AMERICAN CYCLOPEDIA*, vol. xv, art. THEODORUS), has completely subdued Tigré, the most important of the Abyssinian States opposed to him, and having cut off the right hand and right foot of Négousserèh, its king, that chief survived the mutilation but

three days. Theodore is now, without dispute, master of the whole of Abyssinia, and seems disposed to cultivate friendly relations and to introduce civilization and education into his domains.

Proceeding down the eastern coast of Africa, we find the next point of interest in the island of Madagascar. Ranavalona, Queen of the Hovas, the most considerable native tribe of the island, and a most bitter and ferocious persecutor of the Christian missionaries and native converts among the Hovas, died on the 16th of August, 1861, at her capital, Tananarive. Her only son, on her decease, ascended the throne, with the title of Radama II, king of Madagascar. He had been, during his mother's lifetime, friendly to the missionaries and the native Christians, and was regarded as himself a convert. On his accession to the throne he assured the delegations of the English and French Governments of his determination to maintain religious liberty, and the extension of commerce, agriculture, and the arts and sciences among his people. He caused the productions of Madagascar to be represented in the International Exhibition of 1862 in London, and has adopted as his intimate friend and counsellor M. Lambert, a French gentleman, with whom he had been on terms of friendship before his accession to the throne. Great jealousy is manifested by the French and English Governments of the influence exerted by one or the other over the young king, partly from the effect which the preponderating sway of one or the other might have on the colonies which each government possesses in the Indian Ocean, and partly from the fact that the one is the champion of Protestantism and the other of Catholicism in the East. At the latest accounts the French seemed to be gaining the advantage. Radama II was crowned in August, 1862.

South of Mozambique, in the northern part of the Zulu country and extending in the interior toward the Zambezi river, a series of German missionary colonies have been planted by the exertions of Pastor Harms of Ilermannsburg in Hanover. The work was commenced in 1854. About 200 colonists have gone out, and they have ten or twelve stations, and have collected very considerable bodies of natives, who have become partially civilized. The movement is one of great promise.

Passing around the Cape of Good Hope and skirting the coast of Lower Guinea, where there have been no occurrences of political or social interest to call for notice, the Bight of Benin is worthy of attention, where, in August, 1861, the English Government took possession of the kingdom of Lagos, and in 1862 established themselves at Whydah, the two most important centres of the slave trade. This occupation not only promises to accomplish more than any previous measure for the overthrow of the slave trade, but opens a ready route of communication with Abbeokuta and the Yoruba country in the interior, a region



admirably adapted for the culture of cotton and the production of palm and cocoa oils.

The Republic of Liberia has made material progress within the past two years. The recognition of the republic by the United States Government and the appointment of a commissioner to represent it there, have been attended with beneficial results. The Republic has entered with great zeal upon the culture of cotton, coffee, sugar, and rice, and the quality of its productions, which are already exported in considerable quantities to England and the United States, is very superior. Within the past year a college fairly endowed, and with a course of instruction equal to that in most of the colleges in the United States, has been opened in Monrovia. Its president and professors are all men of color, and possess suitable qualifications for their several chairs.

The culture of cotton has received a remarkable impulse throughout Africa. Egypt exported in 1862 a much larger quantity than in any previous year; Liberia and Sierra Leone sent some very excellent long stapled cotton into market; the Yorubas and the tribes dwelling on the banks of the Quorra contributed a considerable quantity; some thousands of bales were sent from Kaffraria and the Cape Colony, and Dr. Livingstone, in his ascent of the Shue and Rovuma, found its cultivation already large and rapidly increasing. In the future, Africa promises to be a powerful rival to the United States for the cotton trade of the world.

**AGRICULTURE.** A condition of war is not usually considered favorable to agricultural progress; but except in those States which have formed the actual battle ground of the past year, the agricultural products of 1862 have been unusually large and profitable. In the Southern States the area devoted to the culture of cotton has been greatly diminished; corn and other cereals having taken its place in extensive districts, while many of the best cotton lands have been trampled by contending armies.

In the Northern States the crops of all descriptions have been abundant. The great export demand for the cereals in 1861, together with the demand for army consumption, led to the planting of a much greater breadth than usual; in winter wheat about 18 per cent. more

area was planted than the previous year, taking the whole country together, and in some of the largest wheat growing States the excess of area planted was much more than this; thus, Wisconsin had 67 per cent. more area than in 1861, Michigan 85 per cent., Ohio 18.7 per cent., while Illinois had only 14 per cent. The yield of winter wheat was 26 per cent. above that of 1861. Of spring wheat the increased area sown was about 23 per cent., but the crop was about 10 per cent. below the average, and perhaps a little more than that below the crop of 1861. Including both kinds of wheat the yield was probably about equal to that of 1861, and fully 10 per cent. above the average of the past five years. The crop of Indian corn was about equal to that of 1861, and 22 per cent. above the average of the past five years. The area planted was no greater than in 1861. Oats were an average crop; a larger area having been sown, but the yield to the acre being about one tenth less. The hay crop was slightly above the average, but the great demand for the army kept the price high, \$30 per ton being the average price paid by Government in the winter of 1862-'3. Potatoes were slightly above the average. Fruits of all kinds were remarkably abundant, the apple crop being fully double that of ordinary years, and the peach crop nearly quadruple. Beans were largely above the average in their yield, as were also hops, tobacco, and clover seed. Sorghum was planted in much larger quantities than ever before, and the production of the syrup and sugar nearly doubled. But for the tendency of the seed to deteriorate by admixture with ordinary broom corn, &c., the yield would have been still greater.\*

The autumn of 1862 developed the fact that there was again a great deficiency in the cereal crops of Western Europe, and that the export demand for American grains and flour would be nearly equal to that of the preceding year. The following table shows the exports of cereals from two of the principal ports in 1861 and 1862, as well as the receipts at Chicago, the largest of the lake ports, and at Boston. A large amount of grain was sent to Europe by way of the Welland canal and the St. Lawrence river; but the amount, as compared with that of the previous year, is not yet ascertainable.

FLOUR AND GRAINS.	New York.		Philadelphia.		Boston.		Chicago.	
	Exported, 1861.	Exported, 1862.	Exported, 1861.	Exported, 1862.	Received, 1861.	Received, 1862.	Received, 1861.	Rec'd, 1862.
Flour, bbls..	8,110,346	2,961,513	862,553	444,391	1,438,999	1,865,838	908,835	1,097,086
Wheat, bush.	28,898,314	25,564,755	2,054,938	1,946,673	29,388	63,015	17,539,909	18,137,538
Corn, "	12,889,850	12,020,848	698,235†	778,522‡	1,938,000	1,889,021	26,548,238	31,146,721
Rye, "	1,000,405	1,104,549	....	....	38,156	39,978	479,005	976,752
Barley, "	8,927	43,061	....	....	....	....	417,129	800,476
Oats, "	160,825	210,669	....	....	1,047,345	1,168,991	....	....

The exports of grain and flour, it will be seen by the above table, in 1862 were not quite

\* These crop statistics have been compiled from the "Crop Reports" of the "American Agriculturist," to which our acknowledgments are tendered.

† Besides 81,673 barrels corn meal.

‡ Besides 50,149 barrels corn meal.

equal to those of 1861, but since the 1st of Jan. 1863, they have been much larger than in the same period of 1862, so that the total export of the crop of 1862 will probably fully equal that of 1861; the high rate of exchange has contributed materially to this result. The prices of breadstuffs at the beginning of the

year 1862 and at its close, were as follows: flour, Jan. 1, 1862, \$5.40 to \$8.25 per barrel; Dec. 31, \$6.05 to \$10. Wheat, Jan. 1, \$1.26 to \$1.52½ per bushel; Dec. 31, \$1.30 to \$1.75. Corn, Jan., 65 to 68 cts. per bushel; Dec., 83 to 95 cts. Rye, Jan., 82 to 85 cts.; Dec., 90 to \$1.02. Barley, Jan., 67 to 80 cts. per bushel; Dec., \$1.33 to \$1.55. The prices of other agricultural products showed a still greater appreciation. Cotton, as was to be expected, rose from 32 to 34 cts. in Jan., to 68 to 72½ cts. in Dec. Rice, \$6.75 to \$7.75 per cwt. in Jan., was \$9 per cwt. in Dec. Potatoes, \$1.88 to \$2.25 per bbl. in Jan., were \$1.60 to \$3 in Dec. Butter, which ranged from 11 to 21 cts. in Jan., was from 16 to 26 in Dec. Mess pork, \$11.75 to \$12.37 per bbl. in Jan., was \$14.62 to \$14.75 in Dec.

Three measures, enacted by Congress in the session of 1861-'2, had an important bearing upon agriculture. The first was the establishment of a distinct department or bureau of agriculture, which had hitherto been attached to the Patent Office. Isaac Newton, Esq., of Pennsylvania, was appointed the commissioner of the new department. Second, the passage of the Homestead bill, designed to encourage the development of the new lands of the West by actual settlers, who should, on certain conditions of loyalty and actual improvement of the lands for a term of three years, become the proprietors in fee simple of a small farm, by paying only the register's fee, was in effect a law for the promotion of agriculture, to which similar enactments on the part of some of the newer States also contributed; and third, the "Agricultural College Act," by which there were granted to each State 30,000 acres of land at the minimum price of \$1.25 per acre, for each senator and representative they might have in Congress, according to the apportionment under the census of 1860, to constitute an endowment for at least one college, in which, without excluding classical or other scientific studies, instruction should be given in agriculture and the principles of the mechanic arts. Ten per cent. of the proceeds of the lands so granted might be used for the purchase of a farm or farms for practical instruction in agriculture, but no portion of it could be expended for buildings or furniture; and the remainder of the proceeds should constitute a permanent and inviolable fund, to be invested in stocks at not less than 5 per cent. (to be made good by the State if lost), the interest whereof should be applied to the teaching of "such branches of learning as are related to agriculture and the mechanic arts, in such manner as the legislatures of the States may respectively prescribe, in order to promote the liberal and practical education of the industrial classes in the several pursuits and professions of life." The several States, in order to avail themselves of the benefits of this act, must signify their acceptance of it within two years from its passage.

The establishment of the "Agricultural Department" seems thus far to have been of much

less advantage to the agricultural interests of the country than its framers had expected. The "propagating garden," established at Washington many years since by the Patent Office, is indeed maintained; and large quantities of seeds are distributed through the members of Congress to their constituents; but no effort has yet been made or proposed to obtain reports of the condition or prospects of the crops, analyses of soils and plants, or to ascertain the meteorology or climatic peculiarities of different sections of the country, the adaptations of their soil or temperature to different classes, species, or varieties of plants. The investigation of the grasses, cereals, and root crops most serviceable and profitable for each section, and the introduction of useful plants and fruits of other countries, or the development under favorable circumstances of some of the wild plants and fruits, are also objects properly coming within the scope of such a department, but as yet they have received little or no attention.

The encouragement of the immigration of practical agriculturists by means of "Homestead" acts, has been tried successfully in other countries less eligibly situated, and bids fair to produce good results here. Texas, before coming into the Union, had largely increased her population by land grants, and Missouri and Michigan have both offered State lands in small quantities to actual settlers, either entirely free or at a nominal price.

The "Agricultural College Act" cannot fail of effecting much good. The necessity of scientific instruction in agriculture has long been felt by many of the more intelligent tillers of the soil; and while some have sought instruction in the great agricultural schools of Germany and France, others have attempted to effect the establishment of such schools in this country, and with some success. The scientific schools attached to Harvard, Dartmouth, and Yale colleges, each provide for instruction in some of the branches of agricultural science, and have proved of great advantage to the intelligent practical farmers who have availed themselves of the course; neither of these, however, has an experimental farm, and for the want of which they have been compelled to confine themselves to theoretical instruction.

The State of Michigan was the first to establish an agricultural college, having appropriated \$50,000 for the purpose in 1855, and purchased a tract of 7,000 acres of land near Lansing, upon which were erected buildings for the institution. In 1857 the Legislature appropriated a further sum of \$40,000, and in May, 1857, the first class was admitted. For some cause the college has within the past two years suspended operations. It is now under the care of the State Board of Agriculture. An agricultural college was incorporated in New York in 1853, but no means were provided for its support. In 1855 a subscription was commenced, and an act passed the Legis-

lature in the same year, loaning the college \$40,000 for twenty years without interest, provided a like sum could be raised by private subscription. This amount, and a considerable sum in excess of it, was raised, a farm of 700 acres purchased in Ovid, Seneca county, and buildings erected sufficient for the accommodation of 150 students; the first class was organized in Dec. 1860, but the college was closed from the depression produced by the war, and has not since been opened. The "People's College" at Havana, Schuyler county, was also intended to be partially agricultural in its character, and has a farm of 200 acres; buildings have been erected, but it is not yet opened for students. The Maryland Agricultural College was incorporated in 1856, and is located on a farm of 400 acres, ten miles north of Washington, D. C.; \$50,000 were raised for it by subscription, and the State makes an annual appropriation of \$6,000 for its support. It was opened for students in 1860 and is still in operation. Its course of instruction differs but little from that of ordinary colleges, and it does not require manual labor from the students. The Minnesota Agricultural College was incorporated in 1853, and has a farm of 320 acres in Glen county, but has not yet erected buildings.

Iowa has purchased a farm, and made a beginning toward the erection of buildings for an agricultural college; but has as yet no organized school. Illinois and Wisconsin have also taken some legislative action relative to such institutions. Oregon, at the session of her Legislature in Sept., 1862, incorporated a State agricultural college at Eugene City, Lane county. There are also collegiate institutions for instruction in agriculture established by private enterprise near Chicago, Illinois, and near Cincinnati, Ohio.

The most complete organization for agricultural training in this country, and the only one now in operation which gives a course approaching in thoroughness and extent the agricultural colleges of the continent of Europe, is the Agricultural College of Pennsylvania, situated on a farm of 400 acres in Centre county, near Bellefonte, not far from the geographical centre of the State. This college was projected in 1853, and incorporated in 1854, at first under the name of the "Farmers' High School of Pennsylvania," which was changed in 1862 to that of "Agricultural College of Pennsylvania." The State Agricultural Society appropriated \$10,000 toward its establishment; the Legislature in 1857 granted \$25,000, upon condition that \$25,000 more were raised by private subscription. A second sum of \$25,000 was granted upon the same terms; and in 1856 Gen. James Irvin gave 200 acres, and sold 200 more at a low price to the trustees, from his estate in Centre county, for the location. Centre county raised about \$15,000 in addition for the college, and, including the State appropriation, there had been raised in 1859 about \$103,000. The buildings were, however, but partially erected, and re-

quired over \$40,000 more for their completion, and other expenditures to the extent of \$15,000 more were needed to fit it for a true agricultural college. In 1861 the Legislature granted a further appropriation of \$50,000, which enabled the corporation to complete their buildings and furnish the necessary apparatus and implements. The college was opened for pupils in 1858; four classes had been organized in the summer of 1862, and two classes had graduated. The trustees had secured at the beginning the services of Evan Pugh, Ph. D. and F. C. S., as the president, and he spent two years in Europe visiting the agricultural colleges, collecting a library and cabinet of geology and mineralogy, and familiarizing himself with the methods of instruction there pursued, and returned in 1860 to take charge of the college. Besides his duties as president, Dr. Pugh also acts as professor of chemistry, scientific agriculture, mineralogy, and geology. There are four other professors: one of English language and literature, and moral and intellectual philosophy; one of botany, physiology, zoology, horticulture, and gardening; one of the mathematical sciences, and one of the science and art of veterinary surgery; two assistants in analytical chemistry, and five superintendents of the farm, nursery garden, &c. The course of study occupies four years, and the student who passes successfully the several examinations and presents a thesis, receives on graduating the degree of bachelor of scientific agriculture (B. S. A.). After a fifth year of study he may receive the degree of master of scientific agriculture (M. S. A.). There are partial scientific and practical courses, without degrees, for those who are unable to take a full course. The course of study comprises for the first year arithmetic and elementary algebra, horticulture, elementary anatomy and physiology, physical geography and elementary astronomy, English grammar and composition, elocution, history, practical agriculture, and the details of management on the college farm. For the second year, advanced algebra and geometry, general chemistry, vegetable anatomy and physiology, zoology and veterinary surgery, geology, paleontology, practical agriculture and horticulture, logic and rhetoric. The studies of the third year are: surveying, navigation, levelling, drafting with the use of instruments, analytics, trigonometry and calculus, natural philosophy, chemical analysis, veterinary surgery, entomology, agricultural botany, practical agriculture and pomology, political and social economy. The fourth year's studies are analytical geometry, differential and integral calculus, engineering, drafting, mechanical drawing, quantitative chemical analysis, veterinary pharmacy, gardening, agricultural accounts and farm management, moral and intellectual philosophy. Every student is required to perform three hours' manual labor on the farm or in the garden, nursery, or orchard daily. The cost of board and tuition, room, rent, and washing, is \$100

per annum, and incidentals bring it up to about \$125. In 1862 the college had 110 students.

The tendency, especially in the Western States, to perform the heavy labors of gathering and securing the crops by the aid of machinery, has stimulated the inventive genius of the people to the utmost, and every year, even at a period when the great interest seems to centre in firearms, projectiles, and other implements of war, witnesses the applications at the Patent Office of a host of inventors of mowing machines, reaping machines, machine rakes, hoes, cultivators, corn shellers, threshers, drills, seed planters, steam ploughs, cow milkers, &c., &c. In 1861 about 400 patents were issued for agricultural implements, and the number was not much less in 1862. Among these were 25 for beehives, 51 for cultivators, 26 for churns, 70 for harvesting implements, 26 for corn planters, 41 for ploughs, 45 for seeding machines, 19 for threshing machines, and smaller numbers for a great variety of other implements. At the international exhibition at London in 1862. 11 of the 85 awards to American exhibitors were for agricultural machines and implements. One of them, the milking machine of Kershaw and Colvin, attracted much attention from the English farmers.

The culture of fruit is yearly becoming a more important branch of American agriculture, and the improvement of the qualities and the selection of the best varieties for cultivation, is a topic of great interest. Many portions of the Northern and Western States possess especial adaptation to fruit crops; among these are notably Northern New York and Ohio, the lower peninsula of Michigan, and Iowa, Wisconsin, and Minnesota, for apples and pears; and New Jersey, Delaware, Southern Pennsylvania, Western Virginia, Kentucky, Tennessee, and Southern Indiana, Illinois, and Missouri, for peaches. In the size and lusciousness of its fruits, California bears away the palm, though it will find a formidable rival in Eastern Oregon, which is destined to be the fruit garden of the Pacific.

Efforts have been made during the past year, and with considerable success, to obtain opinions from large numbers of intelligent fruit growers in different sections of the country relative to the varieties of fruit best adapted to profitable cultivation in their respective regions. The following statement, condensed from the "American Agriculturist" for May, 1862, gives the result of the opinions of seventy-seven eminent fruit growers in the different sections of the Union, in regard to the best varieties of apples, sweet and sour, winter and summer, for cultivation in each section.

In New England reports were received from 17 fruit growers, all of them distinguished for long experience and thorough knowledge of fruit culture. Fourteen of these pronounced the Early Harvest the best summer apple (not sweet), and fifteen the Sweet Bough the best sweet summer apple; after these the Red

Astrachan had 13 votes, William's Favorite 7, Saps of Wine 3, and Golden Sweet 6. For autumn apples the Porter and Gravenstein had each 13 votes, the Fall Pippin 8, the Fameuse 4, and the Maiden's Blush and Northern Sweet 3 each. For winter apples, the whole 17 pronounced the Baldwin best, and of other varieties, the Rhode Island Greening had 14 votes, the Roxbury Russet 11; Hubbardston Nonsuch 7; Peck's Pleasant 6, and the Esopus Spitzenberg and Northern Spy 3 each. The Ladies' Sweeting was the only winter sweet apple commended. In New York the first preferences in summer apples were the same as in New England; of 17 fruit growers all declared for the Early Harvest, 16 for the Sweet Bough, and 13 for the Red Astrachan. In other varieties the selection differed from that of the New England fruit culturists; the American Summer Pearmain and Early Joe receiving 4 votes each, and the Early Strawberry and Primate 3 each. In autumn apples, in the State of New York, the Fall Pippin stood highest, receiving 14 votes, the Gravenstein next with 13 votes, the Porter 11, the Hawley 4, and the Twenty Ounce and Primate each 3. The northern sweet autumn apples most approved were Jersey Sweeting, Autumn Bough and Northern Sweet. Of winter apples, New York, like New England, gave the first preference to the Baldwin, and the second to the Rhode Island Greening; but after these, the Esopus Spitzenberg had 11 votes, the Roxbury Russet 7, Northern Spy and King of Tompkins County each 6, Hubbardston Nonsuch and Swaar each 4, Westfield Seek-no-further and Newtown Pippin each 3. Of sweet winter apples, the Talman Sweeting was the first favorite, having 10 votes, and the Ladies' Sweeting the next. From New Jersey, Pennsylvania, Maryland, Delaware, and Virginia, 13 fruit growers reported. Their preferences for summer apples were the Early Harvest, Red Astrachan and American Summer Pearmain, and for sweet apples the Sweet Bough and Golden Sweet. In autumn apples the Rambo stood highest, receiving 7 votes; next the Fall Pippin and Porter, each having 5 votes; and the Maiden's Blush and Smokehouse each 4. The Jersey Sweeting was the only autumn sweeting approved. In winter apples the Baldwin was the first choice, having 9 votes, and next in order the Rhode Island Greening and Smith's cider apple, having 6 votes each; the Roxbury Russet and Fornwalder, having 4 votes each, and the Northern Spy and Ridge Pippin, having 3 each. The Ladies' Sweeting was the only winter sweet apple named.

From Ohio, Indiana, and Michigan 16 fruit growers reported, and of them 12 gave their suffrages for the Early Harvest, and 6 for the Red Astrachan, among summer apples; while the Summer Queen, and Summer Rose, the Carolina Red June, and the Benoni had each their admirers. Of sweet summer apples the Sweet Bough and Golden Sweet were the favorites.

Among autumn apples the Rambo occupied the highest place, receiving 12 votes, while the Fall Pippin had 10, and the Maiden's Blush 8; other favorites, receiving 8 votes each, were the Porter, Gravenstein, Lowell, Late Strawberry, and Fall Wine. Of sweet fall apples none but the Jersey Sweeting was named. Of winter apples, the Yellow Bellflower received the most votes, and next in order, having 5 votes each, were the Rhode Island Greening and the Belmont; then followed the Westfield Seek-no-further, Rawle's Janet, the Wine Sap, Smith's Cider, and Rome Beauty. The Broadwell and Talman Sweeting were the favorite sweet apples.

From Wisconsin, Illinois, Iowa, and Utah, 9 reports were received. In summer apples the Early Harvest, Red Astrachan, and Carolina Red June were the favorites, while the Keswick Codlin had 3 votes. Of sweet summer apples the High Top was the only one named. In autumn apples the Rambo, as generally throughout the Middle and Western States, takes the lead, followed by the Maiden's Blush, Fameuse, and Fall Pippin, while the Pumpkin Sweet is preferred as a fall sweet apple. Among winter apples the Yellow Bellflower is the prime favorite, and after this in their order Rawle's Janet, the Wine Sap, Westfield Seek-no-further, and Golden Russet. Talman's Sweeting is the only winter sweet apple named.

From Missouri, Kentucky, Tennessee, and Minnesota five reports were received. Of summer apples, the Early Harvest, as everywhere else, was first. After this the Carolina Red June and the Red Astrachan, and for a sweet apple the Sweet Bough. Of autumn apples, none save the Gravenstein was named. Among winter apples, Rawle's Janet occupied the first place, and after it the Yellow Bellflower, Wine Sap, Fornwalder, Limber Twig, and Pryor's Red.

Taking the whole country, the following apples seem to be most generally approved and adapted to all the varieties of climate: for summer apples the Early Harvest, Red Astrachan and Sweet Bough; for autumn the Fall Pippin, Porter, Gravenstein, and Rambo; for winter the Baldwin and the Rhode Island Greening.

A few other varieties, more lately introduced, but possessing high merit, receiving only single votes in these reports, are yet worthy to be named. Among these are the Early Bough and the Summer Paradise among the summer apples; the Willis Sweeting, and the Fall Orange among the autumn varieties; the Vanderveer, an apple of admirable flavor, the Prentiss Russet, and the Moore and Pound Sweetings among the winter apples.

A similar, though less extensive canvass in regard to pears, gives this result, the pears being named in the order of their value: *Standards*—Bartlett, Flemish Beauty, Lawrence, Beurre Clairgeau, Beurre Giffard, Rostiezer, Winter Nelis and Beurre Superfin. *Dwarfs*—Louise Bonne de Jersey, Rostiezer, Duchess

D'Angoulême, White Doyenne, Beurre Diel, Eastern Beurre, Fondante D'Automne, Beurre D'Anjou, Vicar of Wakefield, Winter Nelis, Tyson, Kirtland, Doyenne, D'Ete, Seckel, Flemish Beauty, Bartlett, and Glout Morceau.

In grapes, the following seems to be the verdict of the best grape growers: North of lat. 43° the best wine grapes are the Delaware and Clinton; the best table grapes, the Delaware, Hartford Prolific, Concord and Logan. Between 40° and 43°, for wine, the Delaware, Chester, and Catawba; for the table, the Delaware, Rebecca, Diana, and Isabella. South of 40°, for wine, the Catawba and Delaware; for the table, the Delaware, Catawba, Rebecca, Diana, Isabella, and To Kalon. In strawberries, there is much diversity of opinion; but the prevailing sentiment seems to be in favor, for family use, of the Triomphe de Gand, Hooker's, and Wilson's seedlings. Other varieties may be better for market purposes.

ALABAMA, one of the States bounded on the south by the Gulf of Mexico contains, an area of 50,722 square miles and in this respect is the fourteenth in comparative size. In population it is the thirteenth in rank, containing 964,201, of whom 526,431 are whites, 2,690 free colored, and 435,080 slaves. Of the whites 270,190 are males; 256,081 females; of the slaves 217,766 are males and 217,314 females. In density of population it is the twentieth in rank, having 19.01 inhabitants to the square mile. Its ratio of increase per square mile, during the last ten years, has been 3.80. The number of slaves manumitted during the ten years preceding 1860 was 101, and the number of fugitives was 36. The mortality in the State during the year ending May 31st, 1860, was 12,760, of whom 6,753 were males, and 6,007 females. The most fatal diseases were consumption, croup, diarrhœa, typhoid fever, and pneumonia. The number of violent deaths was 549 males and 356 females, nearly all of which were accidental. Deaf and dumb, 285. The value produced in iron foundries during the same period was \$142,480; coal 10,000 bushels; value of lumber produced \$2,017,641. Flour and meal, \$807,502. Spirituous liquors distilled, 528,800 gallons. Capital invested in cotton manufactures, \$1,306,500; Spindles 28,540, looms 663; annual products, \$917,105. Capital invested in the manufacture of woollen goods, \$100,000; spindles, 1,000; looms, 20. Annual products, \$218,000. Value of leather produced, \$340,400. The improved lands amount to 6,462,987 acres and the unimproved 12,687,913 acres. The cash value of farms is \$172,176,168; value of live stock, \$48,061,805. The crop of cotton amounted in 1860 to 997,998 bales of four hundred pounds each. Wheat, 1,222,487 bushels; rye, 73,942; corn, 32,761,194; oats, 716,435; rice, 499,559 pounds; tobacco, 221,284 pounds; wool, 681,404 pounds. Miles of railroads, 743; cost of construction, \$17,591,188.

The amount of cotton received at Mobile, the

only port of the State, from the first of September to the first of December, 1860, was 362,-370 bales, being nearly one third of the crop raised in the State during that year. The amount received during the same period in 1861, was 22 bales. That which was raised was kept on the plantations, as the blockade cut off all shipments. The commerce of the State was entirely destroyed, except what took place with the adjoining States. In 1862 a very short crop was produced, owing to the small breadth of land planted and the unusual shortness of the yield. The corn crop was also short, but sufficient for home consumption. The wheat and oat crops were an entire failure, owing to an unprecedented drought, which continued through twelve weeks.

Alabama is rich in mineral treasures. Lead and saltpetre, which were greatly needed by the Confederate Government, exist within her limits, and vigorous efforts were made to procure them. Four caves in the State were worked for nitre, which yielded in a few months over twelve thousand pounds, at a cost of seventy-five cents per pound.

The arrival of the Federal forces under Gen. Benjamin F. Butler at Ship Island, at the beginning of 1862, caused great alarm at Mobile. It was supposed that an immediate attack would be made upon that city. The governor, John Gill Shorter, on the 1st of March issued a proclamation to arouse the people to action. He requested the citizens and directed the military officers to burn "every lock of cotton within the State, if it became necessary to prevent it from falling into the hands of the public enemy. He further urged them not to plant one seed of cotton beyond their home wants, but to put down their lands in grain and every other kind and description of farm produce, and to raise every kind of live stock, which might contribute to the relief of the needy families of the soldiers of the army. There were at that time eighteen hundred persons supplied with the necessary articles of food at the free market, which had been opened in Mobile. He further appealed to the people to contribute their shot guns to arm the soldiers, saying:

Men, brave and gallant men, responding to the call of their bleeding country, are rushing by thousands to the field. Their cry is for arms with which to engage the foe. People of Alabama! will you not commit your arms into their hands? People of Alabama! will you not send the shot guns and rifles rusting in your houses, that I may place them in the hands of your own sons to defend your altars and your homes? Agents are appointed all over the State to collect arms. If they do not find you I beg you to find them. Let every sheriff and judge of probate, and all State officers, civil and military, receive and forward arms. Expenses will be promptly paid by the State.

Let every man do something toward arming our troops, if he cannot go to the battle field. Turn your shops into laboratories for the manufacture of arms and munitions of war. Send me thousands of shot guns and rifles, bowie knives and pikes. Send powder and lead and ball. What you cannot afford to give, the State will buy. Let the entire resources and energies of the people be devoted to the one great purpose of war—war stern and unrelenting—war to the knife—

such a war as, in the providence of God, we may be compelled to wage in order to vindicate the inalienable right of self-government.

About the same time, the militia of the counties of Mobile, Washington, Clark, Baldwin, Marengo, Choctaw, Sumter, Green, Perry, Wilcox, Monroe, Dallas, Pickens, Tuscaloosa, Bibb, Shelby, Covington and Antagua were ordered to hold themselves in readiness to be called out for ninety days. The entire body of militia in these populous counties was to take the field, and in addition sixty companies of volunteers. Each company was to consist of one captain, one first and two second lieutenants, five sergeants, four corporals, and not less than sixty-four nor more than one hundred privates. Each company was also to be provided with at least six axes, four hatchets and four shovels and ten days' rations, and be prepared as minute men to proceed to Mobile. Each man was desired to provide himself with twenty rounds of ammunition suitable for the gun he carried, and to take with him his bullet mould and powder flask.

The force which the State had contributed to the war previous to the call of President Davis for an additional quota of 12 regiments, was 22 regiments, and battalions, of at least ten companies of horse and as many of foot. The conscription act followed, by which every man between eighteen and thirty-five was declared to be a soldier. This law created much dissatisfaction in the State, and some suits were commenced to test its constitutionality, but the authorities waived the question, and sustained the Confederate Government.

On the approach of the Federal force in north Alabama (*see* ARMY OPERATIONS), much apprehension was raised that Montgomery might be captured. At the time more than fifty thousand bales of cotton were stored there. Orders were issued by the Government, requiring the railroads to prepare transportation to remove it at once when desired by the owners, and all public drays were impressed into service to remove other portions to a warehouse without the city, where it could be burned without endangering the city. At the same time all persons were forbid to remove the cotton from their warehouses to their private residences. Great alarm was produced throughout the northern part of the State by the approach of the force under Gen. Mitchell. It was supposed that the Federal army would cross the Tennessee river, at the extreme southward point of that river in Alabama, near Gunter's Landing. This is within fifty miles of Gadsden on the Coosa river, which distance might be passed in one day, and the passage of any more steamboats up to Rome might thus be cut off; or the boats might be seized and a force transported to Rome, where some most important establishments for the manufacture of cannon and small arms were in operation. At this point engines and cars in large numbers might also have been captured and a movement made to destroy the bridges of the railroad.

Some expeditions were made by bodies of Federal troops to towns in the northern part of the State, during which many skirmishes occurred. The town of Athens was one of the last in this part of the State to accede to the Confederacy. The threats of devastation by the neighboring town caused this change. Subsequently a body of Federal troops belonging to the brigade of Col. Turchin, were retiring from the town, about the 10th of May, when some of the citizens cheered. The soldiers becoming provoked returned, and made a general onslaught upon the community; stores were sacked and dwellings plundered. The affair was subsequently investigated by a court-martial at Huntsville, and a verdict found dismissing Col. Turchin from service. Previous to the session of the court a commission appointing him a brigadier-general was issued by President Lincoln. On the 25th of July, a guard at Courtland bridge, consisting of two Federal companies of the 10th Kentucky and one company of the 1st Ohio cavalry, were surprised and captured by a force of irregular cavalry. Some other small affairs occurred between the irregular troops of the State and outposts of the Federal forces.

The tax imposed by the Confederate Government in 1861, amounting to two millions of dollars, was paid by the State, and the Legislature also passed an act to guarantee the payment of a million and a half of Confederate bonds, and recommended a similar measure to the other states of the Confederacy.

ARGENTINE REPUBLIC, THE, is bounded on the north by Bolivia, on the east by the Paraguay and Uruguay rivers, south by the Atlantic and Rio Negro, and west by Chili. It lies between the 20th and 40th parallels of S. latitude and 56th and 70th degrees of W. longitude, and contains about 780,000 square miles. President, General Bartolomeo Mitré, elected 1862. Ever since the overthrow of the rule of the Dictator Rosas in 1853, the Argentine Republic has been a prey to internal dissensions. There were two great parties. The one, the old Federal party, sought to impart a kind of organization to the Argentine nationality, and succeeded for a moment in rallying upon this platform all the provinces save that of Buenos Ayres. The other party, the old Unitarians, had its centre in Buenos Ayres, which for some time maintained a separate existence. The constitution of the Argentine Confederacy was adopted in May, 1853, and provided for two chambers, a senate consisting of 30 members, and a house of representatives counting 51 deputies. Buenos Ayres was again united with the Argentine Republic by the peace of San José de Flores, Nov. 10, 1859, and by the act of union concluded June 6, 1860, at Parana. Hostilities between Buenos Ayres and the Argentine Confederacy recommenced in 1861. On Sept. 17, 1861, Gen. Mitré, of Buenos Ayres, defeated the Argentine troops at Pavon. In consequence of this victory, the President of the Argentine

Republic, Dr. Santiago Derqui, abdicated the presidency, and the national government was provisionally intrusted to General Mitré, who was charged with convoking a national congress on May 25, 1862, at Buenos Ayres, to which place the diplomatic corps, which had hitherto resided in Parana, transferred its residence. The congress adopted a new constitution, which provided for the federalization of the city of Buenos Ayres, its relation to the Confederacy being made similar to the relation of the District of Columbia to the United States. The province of Buenos Ayres, however, elects a governor, but his jurisdiction is only "extra-mural," the city being exempt from it. The congress elected Gen. Mitré first president of the reunited Argentine Republic, and he was installed on October 14. Since that time the republic has enjoyed a permanent peace, and both the people and the men in power appear intent on peaceful and industrial improvement.

The republic, as now constituted, embraces 14 provinces, the names, subdivisions, area, and population of which are as follows:

NAMES OF PROVINCES.	Sub-divisions	Area in geog. sq. m.	Population.	Capitals.	Population.
Juguy .....	9	1,577	33,300	Juguy .....	6,900
Salta .....	16	2,365	66,600	Salta .....	11,800
Catamarca .....	8	1,833	50,000	Catamarca .....	12,000
Tucuman .....	9	1,100	58,500	Tucuman .....	11,000
Santiago .....	8	1,525	60,000	Santiago .....	6,000
Corrientes .....	17	2,133	35,000	Corrientes .....	16,000
La Rioja .....	7	1,463	34,500	La Rioja .....	4,000
Cordova .....	14	2,775	130,000	Cordova .....	25,000
Santa Fé .....	4	1,150	40,000	Santa Fé .....	13,000
Entre Rios .....	10	1,409	30,000	Parana .....	3,000
San Juan .....	4	833	63,000	San Juan .....	20,000
San Luis .....	8	1,136	32,000	San Luis .....	5,000
Mendoza .....	8	1,444	60,000	Mendoza .....	13,000
Buenos Ayres .....	51	3,933	350,000	Buenos Ayres .....	120,000

Besides these provinces, the territory of the republic comprises the district Gran Chaco, with 6,667 geographical square miles and about 100,000 free Indians, and the Southern Desert as far as the Rio Negro, with 8,967 square miles.

ARKANSAS, one of the southwestern States, is west of the Mississippi river and south of the State of Missouri. Its population, according to the census of 1860, was 435,450, of whom 324,191 were whites; free colored, 144; slaves, 111,115. The ratio of increase from 1850 to 1860 was, whites, 99.88; free colored, 81.25; slaves, 135.91. The number of each sex of the white population was: males, 171,447; females, 152,666. The number of manumitted slaves was 41; fugitives, 28. The mortality in the State for the year ending May 31, 1860, was 8,860. Consumption, fever, and pneumonia were the most fatal diseases. The number of deaf and dumb in the State was 142, of whom 15 were slaves. The product of iron founderies during 1860 was valued at \$52,000. The value of sawed and planed lumber, \$1,033,185. The number of gallons of spirituous liquors distilled in the year ending June 1, 1860, was 8,500, valued at \$6,125. Value of leather produced, \$115,375. Number of acres of improved land,

1,933,036; do. unimproved, 7,609,988. The cash value of farms was \$91,673,409. Number of horses, 101,249; mules, 44,458; milch cows, 158,873; working oxen, 70,944; sheep, 202,674; swine, 1,155,879. Value of live stock, \$22,040,311. Wheat, 955,298 bushels; rye, 77,869 bushels; corn, 17,753,665 bushels; oats, 502,866 bushels; tobacco, 999,757 pounds; cotton, 367,485 bales, of 400 pounds each; wool, 410,285 pounds; peas and beans, 439,412 bushels; Irish potatoes, 418,000 bushels; sweet potatoes, 1,462,714 bushels; barley, 8,079 bushels. Value of home-made manufactures, \$928,481. Railroads, 38 miles.

The military movements of the Federal troops at the West in the beginning of the year excited great apprehensions in Arkansas. Already twenty-five regiments and six battalions of infantry and cavalry and ten companies of artillery, amounting to 21,500, had been sent to the Confederate army for the war. On the 18th of February Governor Reector issued a proclamation calling into immediate service every man in the State subject to military duty. They were required to appear within twenty days. On the same day a despatch from St. Louis to Washington, sent by Gen. Halleck, announced that Gen. Curtis had driven Gen. Price from Missouri into Arkansas, and that "the flag of the Union is floating in Arkansas." At the same time the commandant at Pocahontas, a short distance southeast of the position of the Federal forces under Gen. Curtis, becoming alarmed, issued the following appeal to the people:

POCAHONTAS, ARK., Feb. 26, 1862.

Reliable information has just been received by me that the enemy, 16,000 strong, left Greenville, Mo., on Saturday last, for the purpose of attacking Pocahontas. It now becomes the duty of every man to turn out promptly, shoulder his musket, and drive the Vandals from the State.

This is probably the advance guard of a much larger force of the enemy. Come without delay, singly or in squads, and rendezvous in Jacksonport. Bring as few horses as possible, as forage is scarce.

MAJOR KEYWORTH, Com'g.

The Confederate force, retiring before Gen. Curtis, abandoned Mudtown. They were subsequently charged with having poisoned the provisions not taken away and the wells of the town. It was reported to Gen. Halleck that forty-two officers and men were thereby poisoned, whereupon he issued, on the 28th of February, an order, saying:

We cannot retaliate by adopting the same barbarous mode of warfare, nor can we retaliate by punishing the innocent for the acts of the guilty. The laws of war forbid this, but the same code authorizes us to retaliate upon the guilty parties.

Persons guilty of such acts, when captured, will not be treated as ordinary prisoners of war, nor will they be shot, but will suffer the ignominious punishment of being hung as felons. Officers are in a measure responsible for the acts of their troops. Officers of troops guilty of such acts, although not themselves the advisers or abettors of the crime, will, when captured, be put in irons and conveyed as criminals to these headquarters. The laws of war make it their duty to prevent such barbarities, and if they neglect that duty they must suffer the consequences.

For the important military movements in the State, see ARMY OPERATIONS. It was beyond the power of the Confederate Government to send aid to Arkansas, and the State was forced to rely upon its own resources and such aid as might be obtained from Missouri, the Indian territory, and Texas. This state of affairs induced the governor, in May, to issue an address to the people, in which his indignation is expressed in these words:

It was for liberty that Arkansas struck, and not for subordination to any created secondary power, north or south. Her best friends are her natural allies, nearest at home, who will pulsate when she bleeds, whose utmost hope is not beyond her existence. If the arteries of the Confederate heart do not permeate beyond the east bank of the Mississippi, let southern Missourians, Arkansians, Texans, and the great West know it and prepare for the future. Arkansas lost, abandoned, subjugated, is not Arkansas as she entered the Confederate Government. Nor will she remain Arkansas, a Confederate State, desolated as a wilderness. Her children, fleeing from the wrath to come, will build them a new ark, and launch it on new waters, seeking a haven somewhere of equality, safety, and rest.

After the military movements in the north-western part of the State, including the battle of Pea Ridge, Gen. Curtis moved to the White river, and occupied Batesville about the 1st of May. Here he was met by many demonstrations of attachment to the Union. Many citizens came forward and took the oath of allegiance to the United States; these were judges of courts, clergymen, and citizens holding positions of influence. His advance being pushed forward on the road to Little Rock, a great excitement was produced there. The governor issued a proclamation calling upon the State militia to repair immediately to its defence. Finding himself not sufficiently supported, Gov. Reector fled, and the State was left without any executive government. Martial law was then declared by Brig.-Gen. Roane, commanding the department, and George C. Watkins was appointed provost marshal. The weakness of Arkansas at this moment was caused by the concentration of all the Confederate military strength at Corinth, and her fate was as much involved in the security of that position as the fate of Tennessee or Mississippi. But while the forces of Arkansas were taken to defend Corinth, ten regiments were taken from Gen. Curtis to reinforce the Federal troops attacking it. This left him in no condition to march upon Little Rock, and the capital of the State thus escaped being captured.

On the 19th of May a skirmish took place near Searcy, between one hundred and fifty men of Col. (acting Brig.-Gen.) Osterhaus's division and a State force under Cols. Coleman and Hicks. The loss was small on both sides. Other skirmishes occurred during the march of Gen. Curtis from Batesville to Helena, of small importance. Bridges were burned by the Arkansas troops across Bayou Des Arc and Cypress river, and about ten thousand bales of cotton on the Arkansas river, and all the cotton and sugar at Jacksonport. By the first of June,



twelve thousand men were collected at Little Rock in answer to the call of the governor, but were very destitute of arms. The State records, however, had been removed to Arkadelphia.

After Gen. Curtis had occupied Helena, the Federal Government appointed John S. Phelps of Missouri military governor, and Col. Wm. F. Switzler secretary for Arkansas. He left St. Louis on Aug. 19, for Helena. It was contemplated at this time that a movement on Little Rock would be made. This however was not done, and the office of governor became of little importance. Two regiments were organized at Helena, composed of citizens of Arkansas; they were chiefly men who had suffered in consequence of their attachment to the Union, and were refugees.

The legislative proceedings in Arkansas possess little interest. An act was passed imposing a tax of thirty dollars per bale on cotton. The object was to favor the cultivation of grain and to discourage that of cotton.

At the State election in August, Flanagan was chosen governor. The opposing candidate was Governor Rector. On the day of inauguration the 1st Monday in November, the governor elect being absent in the army, the duties of the office devolved upon Mr. Fletcher, the president of the senate. An animated contest took place between B. C. Johnson and Augustus H. Garland for the senatorship in the Confederate Congress. Mr. Johnson was elected.

The loss of all communication with the North and foreign countries, stimulated the domestic manufactures of the State. At the close of the year there was in operation a tobacco factory at Burtonville; a large cotton factory in Washington county; another for cotton and wool at Van Buren, Crawford county, another at Norristown, Pope county; another in Pike county. Large saltpetre works were set up in Newton county; and in Independence county some fine caves of the same article were mined. Lead mines in Newton and Sevier counties were worked. Salt was made on the White river, and also near the Louisiana State line. Works on the Washita, with an unlimited supply of brine, commenced vigorous operations. A cannon foundry was at work at Camden; two foundries at Little Rock were at work, one of which furnishes grapeshot for the army. At Hopefield, opposite Memphis, the machine shop of the Memphis and Little Rock railroad was turned into an armory for altering and repairing guns. Several extensive tanneries were commenced in various parts of the State. The State arsenal at Little Rock was converted into an armory for the use of the Confederate Government. At the State penitentiary, gun carriages, caissons, wagons, boots and shoes, clothing, and other material for the army were manufactured.

**ARMY, CONFEDERATE.** The policy usually adopted by countries between which hostilities exist, to conceal from each other not only their military plans, but especially the strength of the forces by which they are to be executed,

has been very carefully pursued by the Confederate Government. No precise statement of its forces in the field has ever been published, or any such details as would enable the United States Government to form an accurate estimate of their numbers. In all the military operations of the Confederate States, large, and probably exaggerated statements of the numbers of men have been made before action, which have been greatly reduced after a conflict. It is also impossible for the most unprejudiced observer to form a correct estimate of the numbers of men from the mere appearance of an army. These circumstances have rendered it difficult to state with precision the number of Southern troops which have been actually brought into service. The entire white population of the States comprising the Confederacy, by the census of 1860, was as follows:

Alabama .....	526,481
Arkansas .....	824,191
Florida .....	77,748
Georgia .....	591,588
Louisiana .....	357,629
Mississippi .....	353,901
North Carolina .....	681,100
South Carolina .....	291,888
Tennessee .....	526,783
Texas .....	421,394
Virginia .....	1,047,411
Total .....	5,449,468

This statement of the population includes the whole of Virginia and the whole of Tennessee. A statement of the population made in the Confederate States, for an estimate of the effects of conscription embraces only one half of Virginia, and two thirds of Tennessee. A statement, however, including all of Virginia and Tennessee, and excluding aid received from Kentucky and Missouri, somewhat exceeds the available force of the Confederate Government. According to the census of 1860 the population of the United States between the ages of eighteen and thirty-five was fifteen per cent. of the aggregate population. Under this ratio the males between those ages in the Confederate States, by the census of 1860, were 817,419. The estimate made in the Confederate States on this basis was for a white population of 5,015,618. The number between the ages of eighteen and thirty-five was put at 752,342. It was also estimated that the volunteers offering who were not embraced in these ages, together with those from Kentucky, Maryland, and Missouri, would make the aggregate soldiery of the Confederacy reach the number of 800,000. It has been generally supposed that the number of volunteers under eighteen and over thirty-five, including also those from Kentucky and Missouri, was large. The Confederate estimates make it about 50,000. From the male population between the ages of eighteen and thirty-five in 1860, amounting to 817,419 if the entire population of the States which have joined the Confederacy is estimated; and amounting to 752,342 if only the population is estimated, which was under the control of the Confederate Government on the 16th of April, when the conscrip-

tion act was passed; there is to be a deduction for those who were not able bodied, or who were exempt from service. This deduction would amount to fifteen per cent. If this deduction is made on the Confederate estimate of 752,342, it is 112,851, and leaves the number of able-bodied men 639,491, to which fifty thousand should be added for volunteers under and above the prescribed ages, and also from Maryland, Kentucky, and Missouri, making the total 689,491. If the deduction of fifteen per cent. is made from the whole population of the Confederate States within the prescribed ages in 1860, viz., 817,419, it is 122,612, and leaves 694,807, with no additions to be made for volunteers from other States or of other ages. The troops furnished by the States at the close of 1861 with their quotas were nearly as follows:

STATES.	Volunteers.	Quota.
Alabama.....	22,000	23,750
Arkansas.....	21,500	21,485
Florida.....	7,000	5,141
Georgia.....	25,000	27,623
Louisiana.....	23,577	23,706
Mississippi.....	17,824	23,284
North Carolina.....	34,024	39,209
South Carolina.....	19,000	18,270
Tennessee.....	44,600	52,948
Texas.....	19,500	28,573
Virginia.....	70,000	66,105
Total.....	305,095	349,954

These volunteers were mostly for twelve months. To these troops in the Confederate service should be added the militia force called out in Georgia, and the volunteers from Maryland, Kentucky, and Missouri, making the entire force about 350,000.

On the 1st of February the President called upon the States for an additional quota of troops: Mississippi, 7 regiments; Alabama, 12; North Carolina, 5; Georgia, 12,000 men, &c. The governors resorted to threats of a draft, and the quotas were completed. The original force had been reduced by sickness and the casualties of war to such an extent, that when the Federal armies commenced operations in February and March, 1862, the Confederate Government was entirely unprepared to

resist them. The first disasters showed to the Government and people their real weakness. Soon after the session of Congress commenced under the Permanent Government, President Davis sent in a Message urging the passage of a conscription act. One was passed on the 16th of April, which declared every man, with a few exceptions, between the ages of 18 and 35 years, a soldier. (See CONFEDERATE STATES.) Thirty days were allowed in which to volunteer, after which the law took absolute effect. All contracts with volunteers were annulled, and those over 35 and under 18 years were required to continue in the service 90 days after their term of enlistment expired. Before the ninety days expired an order from the Secretary of War extended the time of service. This conscript act thus brought out the full number liable to conscription, 639,491, reduced by the losses of war and sickness, exemptions, and desertions up to midsummer 1862, which reduction was not less than 100,000 men, and probably near 200,000. The weakness of the Confederate armies was however so sensibly felt, that the press publicly declared in the middle of August that the Confederacy had not 300,000 effective men in the field, and Congress, in October, passed a second conscription act, by which the President was authorized to call into the field all men between the ages of 35 and 45 years. The act provided that only such portions of this conscription should be called out as the President deemed necessary. By the 1st of November the Secretary of War issued an order for the enrolment of all persons, except exempts, between 18 and 45 years of age. This law was declared to be "odious to a large class of the people." A few regiments of Indians have been brought into the field, but they have proved so troublesome that the experiment has not been tried any further.

The following is an official list of general officers in the service in August, 1862. The major and brigadier generals are said to belong to the Provisional Army, their commissions having been granted under the Provisional Government, or prior to 1862:

<i>General-in-Chief.</i>	*William J. Hardee..... Georgia.	Henry A. Wise..... Virginia.
*Robert E. Lee..... Virginia.	*Benj. Huger (rel'd)..... South Carolina.	*August R. Lawton..... Georgia.
<i>Adjutant and Inspector-General.</i>	*James Longstreet..... Alabama.	G. J. Pillow (rel'd)..... Tennessee.
*Samuel Cooper..... Virginia.	*J. B. Magruder..... Virginia.	*Daniel S. Donelson..... Tennessee.
<i>Quartermaster-General.</i>	*Thomas J. Jackson..... Virginia.	*David E. Jones..... South Carolina.
*A. C. Myers..... Louisiana.	*Manassah Lovell..... District Columbia.	*John H. Winder..... Maryland.
*Larkin Smith (Assistant).	*E. Kirby Smith (rel'd)..... Florida.	*Ashbel A. Early..... Virginia.
<i>Chief of Ordnance.</i>	William W. Loring..... North Carolina.	*Arnold Elzey..... Maryland.
*Benjamin Huger..... South Carolina.	Sterling Price..... Missouri.	*Samuel Jones..... Virginia.
<i>Generals—Regular Army.</i>	*John P. McCown..... Tennessee.	*C. O. Sibley (dead)..... Louisiana.
*Samuel Cooper..... Virginia.	*Daniel H. Hill..... North Carolina.	*Wm. H. C. Whiting..... Georgia.
*Joseph E. Johnston..... Virginia.	*Richard S. Ewell..... Virginia.	*Daniel Ruggles..... Virginia.
*Robert E. Lee..... Virginia.	*John C. Pemberton..... Virginia.	Charles Clark..... Mississippi.
*P. G. T. Beauregard..... Louisiana.	*Ambrose P. Hill..... Virginia.	*Roswell S. Ripley..... South Carolina.
*Braxton Bragg..... Louisiana.	John C. Breckinridge..... Kentucky.	*Isaac R. Trimble..... Maryland.
<i>Major-Generals—Provisional Army.</i>	Wm. S. Cheatham..... Tennessee.	*Paul O. Hebert..... Louisiana.
*Leonidas Polk..... Louisiana.	Thomas C. Hindman..... Arkansas.	*Richard C. Gatlin..... North Carolina.
*Earl Van Dorn..... Mississippi.	*Richard H. Anderson..... South Carolina.	L. Pope Walker..... Alabama.
*Gustavus W. Smith..... Kentucky.	*James E. B. Stewart..... Virginia.	*Albert B. Blanchard..... Louisiana.
*Theo. N. Holmes..... North Carolina.	*Simon B. Buckner..... Kentucky.	*Gab. J. Rains (killed)..... Kentucky.
	*James M. Withers..... Alabama.	*Lafayette McLaws..... Georgia.
	<i>Brigadier-Generals.</i>	*Thomas F. Dayton..... South Carolina.
	John B. Floyd (rel'd)..... Virginia.	*Lloyd Tilghman..... Kentucky.
		*Nat. G. Evans..... South Carolina.

*Cadmus C. Wilcox.....Tennessee.	John S. Williams.....Kentucky.	Ripley, Ohio; ——— Leadbeater, Connecticut; S. G. Frunch, New Jersey; D. M. Froot.
Richard E. Rhodes.....Alabama.	N. B. Forrest.....Tennessee.	CASUALTIES, &c.—Killed.—Maj.-Gen. A. S. Johnston,* Texas, at Shiloh, April 6, 1862.
Richard Taylor.....Louisiana.	Robert E. Garland (killed).....Virginia.	Brig.-Gen. R. S. Garnett,* Va., at Carriek's Ford, July 11, 1861.
*James H. Trapier.....South Carolina.	*A. W. Reynolds.....Virginia.	Brig.-Gen. Bernard E. Bee,* S. C., at Manassas, July 31, 1861.
*Samuel G. French.....Mississippi.	—— Jenkins.....South Carolina.	Brig.-Gen. F. K. Zollnoffer, Tenn., at Somerset, January 19, 1862.
William H. Carroll.....Tennessee.	*—— Pender.....North Carolina.	Brig.-Gen. Ben McCulloch, Texas, at Pea Ridge, March 7, 1862.
*Hugh W. Mercer.....Georgia.	Edward W. Gantt.....Arkansas.	Brig.-Gen. A. H. Gladden, La., at Shiloh, April 6, 1862.
Humphrey Marshall.....Kentucky.	Solon Borland.....Arkansas.	Brig.-Gen. T. W. Ashby, at ———, May —, 1862.
*Alexander P. Steuart.....Tennessee.	*M. L. Smith.....Mississippi.	Brig.-Gen. Robert Hatton, Tenn., at Seven Pines, May 31, 1862.
*W. Montgomery Gardner.....Georgia.	*William B. Tallafarro.....Virginia.	Brig.-Gen. Richard Griffith, Miss., before Richmond, June 27, 1862.
*Richard B. Garnett.....Virginia.	*George E. Pickett.....Virginia.	Brig.-Gen. C. S. Winder,* Md., at Cedar Mountain, August 9, 1862.
William Mahone.....Virginia.	—— Wright.....Georgia.	Brig.-Gen. J. T. Hughes, Mo., at Independence, August —, 1862.
L. O'B. Branch (killed), North Carolina.	—— Helm.....Kentucky.	Brig.-Gen. Robert E. Garland, Va., at South Mountain, September 14, 1862.
Maxey Gregg.....South Carolina.	George Maurey.....Tennessee.	Brig.-Gen. Starke, N. C., at Antietam, September 17, 1862.
Robert Toombs.....Georgia.	Blanton Duncan.....Kentucky.	Brig.-Gen. Law O'B. Branch, N. C., at Antietam, September 17, 1862.
*George H. Stewart.....Virginia.	*L. A. Armistead.....Virginia.	Brig.-Gen. Henry Little, Missouri, at Iuka, September 19, 1862. Total—15.
*Wm. W. Mackall.....District Columbia.	—— Semmes.....Georgia.	Acting Brig.-Gen. F. S. Bartow, Ga., at Manassas, July 21, 1861.
*Henry Heth.....Virginia.	—— Maxey.....	Acting Brig.-Gen. James McIntosh, at Pea Ridge, March 7, 1862. Total—18.
*Johnson K. Duncan.....Louisiana.	S. R. Gist.....South Carolina.	<i>Dead.</i> —Brig.-Gen. J. B. Grayson, Ky.; T. A. Flourney, Ark.; Phillip St. George Cooke,* Va. (suicide)—3.
John E. Jackson.....Georgia.	*D. M. Froot.....Missouri.	<i>Resigned.</i> —Maj.-Gens. David E. Twiggs, Ga. (since dead); M. L. Bonham, S. C.; George B. Crittenden, Ky.; Brig.-Gens. H. R. Jackson, Ga.; T. T. Fauntleroy, Va.; G. W. Randolph, Va.; L. T. Wigfall, Texas; S. C. Anderson, Tenn.; J. R. Anderson,* Va.; Albert Pike, Ark.; W. H. T. Walker,* Ga.—11.
*Edward Johnson.....Virginia.	Beverly R. Robertson.....Virginia.	
Howell Cobb.....Georgia.	J. B. S. Roane.....Arkansas.	
Joseph L. Hogg.....Texas.	C. L. Stevenson.....	
William S. Featherston.....Mississippi.	Wade Hampton (dead), South Carolina.	
Roger A. Pryor.....Virginia.	A. G. Jenkins.....Virginia.	
*John H. Forney.....Alabama.	—— Fields.....	
*John B. Villepique (dead), Georgia.	—— Martin.....North Carolina.	
*Bushnel E. Johnson.....Tennessee.	*Fitz Hugh Lee.....Virginia.	
*Thomas K. Jackson.....	John E. Jones.....Virginia.	
*Thomas Jordan.....Virginia.	James E. Slaughter.....	
*John S. Bowen.....Missouri.	Henry Hayes.....Louisiana.	
*John B. Hood.....Texas.	Henry W. Hilliard.....Alabama.	
*G. B. Anderson (k'd), North Carolina.	*Abraham Buford.....Kentucky.	
*Thomas M. Jones.....Virginia.		
J. J. Pettigrew.....South Carolina.		
Albert Rust.....Arkansas.		
James J. Ramsey.....Georgia.		
Hamilton P. Bee.....Texas.		
Henry McCulloch.....Texas.		
William Preston.....Kentucky.		
*Henry Little (killed), Missouri.		
*R. Ransom.....North Carolina.		
Martin E. Greene.....Missouri.		
Thomas R. R. Cobb (killed), Georgia.		
—— Wood.....Alabama.		
—— Kemper.....South Carolina.		
—— Kershaw.....South Carolina.		
—— Leadbeater.....Tennessee.		
—— Armstrong.....		

\* Graduates of West Point.

The Confederate army in Virginia, near the close of the year, was in a most destitute condition. The following statement, dated at Winchester, Virginia, on September 26, was circulated through the Confederate States, as entirely reliable, and made the basis of appeals to the people to contribute to the relief of the soldiers:

I can recall no parallel instance in history, except Napoleon's disastrous retreat from Moscow, where an army has ever done more marching and fighting, under such great disadvantages, than Gen. Lee's has done since it left the banks of the James river.

This army proceeded directly to the line of the Rappahannock, and, moving out from that river, it fought its way to the Potomac, crossed the stream, and moved on to Frederick and Hagerstown, had a heavy engagement at Boonsboro' Gap, and another at Crampton Gap below, fought the greatest pitched battle of the war at Sharpsburg, and then recrossed the Potomac back into Virginia. During all this time, covering the full space of a month, the troops rested but four days! And let it always be remembered, to their honor, that of the men who performed this wonderful feat one fifth of them were barefooted, one half of them in rags, and the whole of them half famished. The country from the Rappahannock to the Potomac had been visited by the enemy with fire and sword, and our transportation was insufficient to keep the army supplied from so distant a base as Gordonsville; and, when provision trains would overtake the army, so pressing were the exigencies of their position, the men seldom had time to cook. Their difficulties were increased by the fact

that cooking utensils in many cases had been left behind, as well as everything else that would impede their movements. It was not unusual to see a company of starving men have a barrel of flour distributed to them, which it was utterly impossible for them to convert into bread with the means and the time allowed to them. They could not procure even a piece of plank or a corn or flour sack upon which to work up their dough.

Do you wonder, then, that there should have been stragglers from the army?—that brave and true men should have fallen out from sheer exhaustion, or in their efforts to obtain a mouthful to eat along the roadsides? Or that many seasoned veterans, the conquerors in the valley, at Richmond and Manassas, should have succumbed to disease, and been forced back to the hospital? I look to hear a great outcry against the stragglers. Already lazy cavalrymen and dainty staff officers and quartermasters, who are mounted and can forage the country for something to eat, are condemning the weary private, who, notwithstanding his body may be covered with dust and perspiration, and his feet with stone bruises, is expected to trudge along under his knapsack and cartridge box, on an empty stomach, and never turn aside for a morsel of food to sustain his sinking limbs. Out upon such monstrous injustice! That there has been unnecessary straggling is readily admitted; but, in a large majority of cases, the men have only to point to their bleeding feet, tattered garments, and gaunt frames for an answer to the unjust charge. No army on this continent has every accomplished as much or suffered as much as the army of Northern Virginia within the last three months. At no period during the first Revolutionary War, not even at Valley Forge, did our

forefathers in arms encounter greater hardships, or endure them more uncomplainingly.

But great as have been the trials to which the army has been subjected, they are hardly worthy to be named in comparison with the sufferings in store for it this winter, unless the people of the Confederate States, everywhere and in whatever circumstances, come to its immediate relief. The men must have clothing and shoes this winter. They must have something to cover themselves when sleeping, and to protect themselves from the driving sleet and snow storms when on duty. This must be done, though our friends at home should have to wear cotton, and sit by the fire. The army of Virginia stands guard this day, as it will stand guard this winter, over every hearthstone throughout the South. The ragged sentinel who may pace his weary rounds this winter on the bleak spurs of the Blue Ridge, or along the frozen valleys of the Shenandoah and Rappahannock, will also be your sentinels, my friends, at home. It will be for you and your household that he encounters the wrath of the tempest and the dangers of the night. He suffers, and toils, and fights for you, too, brave, true-hearted women of the South. Will you not clothe his nakedness, then? Will you not put shoes and stockings on his feet? Is it not enough that he has written down his patriotism in crimson characters along the battle road from the Rappahannock to the Potomac? And must his bleeding feet also impress their mark of fidelity upon the snows of the coming winter?

It is not necessary to counsel violent measures; but it is not expected that any person will be permitted to accumulate leather and cloth for purposes of speculation. The necessities of the armies rise up like a mountain, and cannot, and will not be overlooked. It was hoped at one time that we might obtain winter supplies in Maryland. This hope was born after the army left Richmond, and has now miserably perished. The Government is unable to furnish the supplies, for they are not to be had in the country. If it had exercised a little foresight last spring and summer, when vessels were running the blockade with cargoes of calico, linen, and other articles of like importance, a partial supply at least of hats, blankets, shoes, and woollen goods might have been obtained from England. But foresight is a quality of the mind that is seldom put in practice in these days.

But whatever may be done by the people should be done immediately. Not one moment can be lost that will not be marked, as by the second-hand of a watch, with the pangs of a sufferer. Already the hills and valleys in this high latitude have been visited by frost, and the nights are uncomfortably cool to the man who sleeps upon the ground. Come up, then, men and women of the South, to this sacred duty! Let nothing stand between you and the performance of it. Neither pride nor pleasure, nor personal ease and comfort, should withhold your hands from the holy work. The supply of leather and wool, we all know, is limited; but do what you can, and all you can, and as soon as you can. If you cannot send woollen socks, send half-woollen or cotton socks; and so with under clothing, coats, and pants; and if blankets are not to be had, then substitute comforts made of dyed osnaburgs, stuffed with cotton. Anything that will keep off the cold will be acceptable. Even the speculator and extortioner might forego their gains for a season, and unite in this religious duty.

If the army of Virginia could march through the South just as it is—ragged, and almost barefooted and hatless; many of the men limping along, and not quite well of their wounds and sickness, yet cheerful, and not willing to abandon their places in the ranks; their clothes riddled with balls, and their banners covered with the smoke and dust of battle, and shot into tatters, many of them inscribed with "Williamsburg," "Seven Pines," "Gaines's Mill," "Garnett's Farm," "Front Royal," "McDowell," "Cedar Run," and other victorious fields—if this army of veterans, thus clad and shod, with tattered uniforms and banners, could

march from Richmond to the Mississippi, it would produce a sensation that has no parallel in history since Peter the Hermit led his swelling hosts across Europe to the rescue of the Holy Sepulchre.

The Governor of North Carolina issued an appeal to the citizens in behalf of the soldiers of that State in the following words:

After the most strenuous exertions on the part of its officers, the State finds it impossible to clothe and shoe our soldiers without again appealing to that overflowing fountain of generosity—the private contributions of our people. The rigors of winter are approaching, our soldiers are already suffering, and must suffer more if our sympathies are not practical and active. The quartermaster's department is laboring faithfully to provide for them; but owing to speculation and extortion, will fall short. The deficiency must be supplied by the people. We shall have an active winter campaign, and how can our troops, if ragged, cold and barefoot, contend with the splendidly equipped columns of the enemy.

The articles most needed, and which the State finds it most difficult to supply, are shoes, socks and blankets, though drawers, shirts, and pants would be gladly received. If every farmer who has hides tanning would agree to spare one pair of shoes, and if every mother in North Carolina would knit one strong pair of either thick cotton or woollen socks for the army, they would be abundantly supplied. A great lot of blankets also might yet be spared from private use, and thousands could be made from the carpets upon our parlor floors. With good warm houses and cotton bed clothing we can certainly get through the winter much better than the soldiers can with all the blankets, we can give them.

The colonels of militia regiments throughout the State are hereby appointed agents for the purchase and collection of all such articles as can be spared by our people, who, through their respective captains, are ordered immediately to canvass every county and visit every citizen in their beats for this purpose. A liberal price will be paid for everything where the owner feels that he or she is not able to donate it, and active agents will immediately forward them to our suffering regiments. Expenses will be allowed the officers engaged in this duty, and transportation furnished the colonels or their agents to bring the articles to Raleigh.

And now, my countrymen and women, if you have anything to spare for the soldier, in his name I appeal to you for it. Do not let the speculator have it, though he offer you an enormous price; spurn him from your door, and say to him that our brave defenders have need for it, and shall have it without passing through his greedy fingers. Do not place yourselves among the extortioners—they are the vilest and most cowardly of all our country's enemies; and when this war is ended, and people come to view the matter in its proper light, you will find that the most detested Tories are more respected than they. When they tempt you with higher prices than the State offers; just think for a moment of the soldier, and what he is doing for you. Remember, when you sit down by the bright and glowing fire, that the soldier is sitting upon the cold earth; that in the wind which is whistling so fearfully over your roof, only making you feel the more comfortable because it harms you not, he is shivering in darkness on the dangerous outpost, shuddering through the dreary hours of his watch. Remember that when you come forth in the morning well fed and warmly clad, leading your families toward the spot where the blessed music of the Sabbath bells tells you of the peaceful worship of the God of Peace, the soldier is going forth at the same moment, perhaps, half fed, after a night of shivering and suffering, to where the roar of artillery and shout of battle announce that he is to die that your peace and safety may be preserved. Oh, remember these things, generous and patriotic people of North Carolina, and give freely of your perishable

goods to those who are giving all that mortal men can give for your safety and your rights. Z. B. VANCE.  
 RALEIGH, Oct. 15, 1862.

These appeals were not without effect. As an instance, the proprietors of the Pulaski House, in Mobile, contributed the carpeting of one hundred and twenty rooms, which was estimated to be sufficient to make five hundred blankets.

The straggling from the army, as the winter approached, was without a parallel. The press, the President, and officers of the Confederate and State Governments appealed to the people, and particularly to the women, to frown upon all stragglers, and use every means to secure their apprehension. It was declared that more than half the men who went into service from the northeastern counties of the State of Georgia were at home without leave, and most of them were skulking in the mountains to avoid being arrested. Others had banded together under a few desperate leaders to resist any attempts that might be made to arrest them, or to release from the jails those who had been arrested. Some of those bands had arms and ammunition, and subsisted by plunder. They were volunteers and not conscripts, as the conscript laws had never been enforced in that section.

**ARMY OF THE UNITED STATES.** The United States, unlike the great powers of Europe, has not hitherto considered a large standing army necessary, and has only maintained a sufficient force to garrison moderately its forts and fortresses, and to form a nucleus for the organization and training of a large volunteer army in time of war. The policy of the Government being eminently peaceful, it has been only on great emergencies that it has been necessary to call out any considerable force of militia or volunteers. Aside from the war of 1812 and the Mexican, no such force had ever been called for previous to the present war; and the militia of particular districts had only occasionally been summoned in small numbers to suppress local insurrections or riots. It may be well, therefore, to give a brief historical sketch of the origin, growth, and present condition of the regular or standing army of the United States, and then to speak of the militia and volunteer troops.

I. *The Regular Army.*—The Constitution of the United States, Art. 1, sec. 8, empowers Congress "to raise and support armies;" and Art. 2, sec. 2, designates the President as "commander in chief of the army and navy, and of the militia when called into the service of the United States." The War Department, as the agency by which the President was to carry into effect these provisions of the Constitution, was established by act of Congress, Aug. 7, 1788. At first the standing army was organized under the "Original Rules and Articles of War," adopted by the Continental Congress of 1776, with such slight modifications as were necessary to adapt them to the altered condition of affairs. This military code formed the

basis of the present articles of war, though greatly modified in 1806.

In 1790, Congress fixed the number of rank and file in the army at 1,216 men; in 1791 an additional regiment of 900 men was authorized. In 1796, the standing army consisted of 4 regiments of infantry, of 8 companies each; 2 companies of light dragoons; and a corps of artilleryists and engineers; and the President was authorized by Congress to appoint one major-general and one brigadier-general, each with a suitable staff, for the command of this force; but in 1797 the major-general was discharged as being unnecessary.

In 1798, a provisional force of 10,000 men was authorized owing to the threatening attitude of France; but the danger passed over and the army returned to its former small proportions. The war of 1812 had been long foreseen, and provision made for it not by an increase of the regular army but by the authorization of a provisional volunteer force of 80,000 to 85,000 men, and at the close of the war in 1815 this provisional army was disbanded; but no permanent modifications were made in the peace establishment till 1821.

By the act of Congress for the organization of the army in 1821, 7 regiments of infantry, 4 of artillery, and a corps each of engineers, topographical engineers, and ordnance were established and provision made for medical, adjutant-general's, quartermasters', paymasters', and commissary-generals' departments. Irregular mounted rangers, occasionally called into the service, formed the only cavalry force of the army till 1833, when a regiment of dragoons was authorized; and in 1836 a second was added.

At the commencement of the Mexican war in May, 1846, the whole number of troops of the line was 7,244. The regular army was increased during the war, by the enlistment, to twenty thousand soldiers, aside from the volunteer troops; this addition was made to the different arms of the service as follows: 9 infantry regiments (one of them a *coltigueur* regiment, that is, light horsemen); a third regiment of dragoons, and a regiment of mounted riflemen, who, however, served on foot during the war. At the close of the war the third regiment of dragoons and the 9 infantry regiments were discharged, and the only permanent increase of the army was the mounted rifles.

The grade of lieutenant-general by brevet, which had not existed since the death of Washington, was revived and bestowed on Maj.-Gen. Winfield Scott in 1855. The same year, there were added to the regular army 2 regiments of infantry and 2 of cavalry.

On the 1st of January, 1860, the whole number of commissioned officers in the regular army was 1,088; of non-commissioned officers, musicians, artificers, and privates, 11,848, forming a total of line troops of 12,931.

In August, 1862, the following was the number of officers of each grade and privates, in the regular army:

Major-Generals.....	5	Regimental hospital	
Brigadier-Generals....	13	stewards.....	13
Colonels.....	97	Battalion sergeant-ma-	
Lieutenant-Colonels...	79	jors.....	37
Majors.....	243	Battalion quartermas-	
Aides-de-camp.....	88	ter-sergeants.....	37
Captains.....	677	Battalion commissary-	
Adjutants.....	30	sergeants.....	37
Regimental Quarter-		Battalion hosp'l stew-	
masters.....	30	ards.....	37
Regimental Commis-		First sergeants.....	448
saries.....	6	Company quartermas-	
Battalion Adjutants...	27	ter-sergeants.....	54
First Lieutenants.....	648	Company commissary-	
Second Lieutenants....	500	sergeants.....	73
Supernumerary Lieut-		Sergeants.....	1,790
enants.....	73	Corporals.....	8,090
Military Storekeepers.	88	Musicians.....	1,298
Hospital Chaplains....	109	Farriers and black-	
Medical cadets.....	70	smiths.....	144
Sergeant-Majors.....	21	Artificers.....	415
Quartermaster-Serg'ts.	21	Saddlers.....	73
Commissary Sergeants	7	Wagoners.....	84
Leaders of bands.....	9	Teamsters.....	144
Chief musicians.....	40	Privates.....	81,479
Saddler's sergeants....	6	Ordnance, enlisted men	905
Chief trumpeters.....	6		
Chief farriers.....	6	Total commissioned.	2,888
Ordnance sergeants....	98	Total enlisted.....	40,626
Hospital stewards.....	201		
Aggregate line troops....			43,014

The pay of both officers and men is the same as that of the volunteers, the discipline somewhat more strict, and the drill generally more perfect. The titles of officers are, except in the case of the highest officer, lower than in the volunteers—colonels, lieutenant-colonels, majors, captains, and in one or two cases, even lieutenants in the regular army, being brigadier-generals of volunteers, and the first three, in some instances major-generals in the volunteer army. Promotion in the regular army is, however, greatly coveted by men who intend to make military life a permanent profession.

II. *The Militia Force.*—An act was passed by Congress, May 8, 1792, providing for a uniformed militia, to be raised in each State, and to form the reserve force which could be called out in case of invasion or rebellion; but during the long period of peace, the militia organization had been almost wholly neglected. Most of the States had at one time or another proper laws for the State organization of the militia, but these were generally but little regarded, and the fines imposed for non-appearance on parade were regarded as a vexatious exaction. The commencement of the present war found not more than two or three States with a militia organization sufficiently perfect to admit of a response through it to the President's proclamation of April, 1861. In most of the States even the three months' troops were volunteers. Since that time nearly every State has passed a militia law, which will provide against the evils of being obliged to send into the field in case of war entirely unorganized and undisciplined troops. These laws differ somewhat in detail in the different States; but all provide for the enrolment of all able-bodied white male citizens (some, as for instance, Rhode Island and Massachusetts, include colored citizens also) between the ages of 18 and 45, with certain specified exceptions, among which are usually clergymen, teachers, State and United States officers,

railroad and telegraph employes, firemen, and convicts, idiots, and drunkards; these are divided into two classes, the active and inactive militia, the first embracing the voluntary companies and such other companies organized under the law as may be necessary to make up a given number of regiments and brigades, such number to be completed if needful by draft from the enrolled men between 18 and 30; the others, including all between 30 and 45, to form the inactive militia, and required under penalty of a fine or tax of \$1 per annum to appear on a specified day and answer to their names. The active militia have a full corps of officers, and are required to be uniformed and to have all the necessary arms and equipments at their arsenals in condition for immediate service; they are also to be called out once or twice a year for a camp drill of two or three days, and are paid for their time and service. The officers are drilled and instructed in their duties two, three, or four times a year, and receive a moderate compensation for their time. It has been a prevalent idea among the militia, having perhaps some foundation in the law of 1792, that militia troops could not be required to go out of their own State to fight, and could not be retained in the United States service more than three months; and these ideas led more than once, as the readers of the history of the war of 1812 will remember, to serious and disastrous results; but Congress, in its session of 1861-'2, passed an act (July 17, 1862) authorizing the President to call out the militia for nine months, and to use them either for the filling up of old regiments or the organization of new corps. It is impossible to give anything more than an approximation of the number of the militia enrolled or who should be enrolled in the loyal States. The report of the adjutant-general of the United States in 1860, based, however, in many of the States on returns made from 7 to 15 years previous, gave the number (omitting Iowa, Oregon, New Mexico, Washington, Kansas, and Nebraska) as 3,070,987, officers and privates; this would be very nearly one tenth of the population, and adopting this as a basis of calculation, the number of men between 18 and 45 capable of bearing arms in the loyal States would be 2,242,841. This estimate is probably below rather than above the truth. Of the 77,875 three months' troops, a little more than one half were militia; of the 30,000 or 40,000 called out in the summer of 1862, all or nearly all were militia. There were also some militia regiments among the nine months' force raised under the call of August 9, 1862.

III. *The Volunteer Army.*—It was evident at the commencement of this war, as in every war in which the nation has been engaged, that though the militia of the several States might render efficient service in the beginning, while other forces were in the process of organization, they could not be depended upon for a long war; the tenure of their service (three

months being then generally understood to be the longest term for which they could be called out), and the mode of appointing their officers by the suffrages of the privates, were fatal to their use for any considerable period, and volunteers were called for within four weeks from the first proclamation, though unfortunately not in sufficiently large numbers at first. In July Congress, by act of July 22, 1861, authorized the raising of 500,000 volunteers, and on the 25th of the same month, probably inadvertently gave authority for the raising of 500,000 more.

How many were actually raised under these two acts is somewhat uncertain. Secretary Cameron, in his report of Dec. 1, 1862, gives the aggregates as follows: Three months' regiments, 77,875 men; volunteers for the war, 640,687. The reports of the adjutant-generals of the different States show a very considerable difference between the number raised and the number credited therein in this report; some claiming many thousands more, and others considerably less than the number assigned them by the Secretary. At the date of the Secretary's report a large number of regiments organizing under the call had not been mustered into the service; many of the regiments indeed were not fully organized till January or February. About the 1st of June, 1862, a call for militia troops for three months' service was made upon several of the States, and Massachusetts, Rhode Island, New York, Pennsylvania, and Ohio sent forward regiments numbering in all nearly 40,000 men. In August and September the raids of the Confederate forces along the Ohio river, and the invasion of Maryland by the Confederate generals Lee, Jackson, and Stuart, led to the calling out of militia and volunteer troops in large numbers, from Pennsylvania, Ohio, Indiana, and Illinois, who were discharged when the enemy had been driven back. On the 1st of July, 1862, the President called for 800,000 more volunteers for the war, and on the 9th of August for 800,000 for nine months, who were to be drafted unless they volunteered promptly. There was subsequently considerable vacillation on the part of the Government in regard to the force to be raised under these two calls. In Pennsylvania a part of those enlisted under the first call were enlisted for twelve months only; in other States an excess raised under the first was allowed to be credited to the second; and in some instances an excess under the previous calls was allowed to count on these. There was very little drafting; probably up to Feb. 1, 1863, there were not 10,000 drafted men in the army. This was mainly due to the great exertions made in the loyal States to promote volunteering and the very liberal bounties offered by States, counties, cities, towns, and individuals, to those who would enlist. The following table, prepared from official reports from each loyal State, shows the number of troops furnished by each for the war to Dec. 1, 1862:

STATES.	Three months' troops, call of April 15, 1861.	All others to Dec. 1, 1862.
Maine.....	768	80,240
New Hampshire.....	779	16,000
Vermont.....	780	19,066
Massachusetts.....	8,786	72,107
Rhode Island.....	1,285	10,000
Connecticut.....	775	28,551
New York.....	10,188	*219,059
New Jersey.....	8,068	27,400
Pennsylvania.....	19,199	1280,000
Delaware.....	775	2,500
Maryland.....	.....	10,000
West Virginia.....	779	20,000
Kentucky.....	.....	55,000
Missouri.....	9,256	88,081
Ohio.....	10,226	164,402
Indiana.....	6,000	94,698
Illinois.....	4,941	180,059
Michigan.....	781	47,220
Wisconsin.....	792	42,567
Minnesota.....	880	10,257
Iowa.....	968	50,000
Kansas.....	.....	14,000
California.....	.....	9,000
Oregon.....	.....	1,500
Colorado.....	.....	2,200
Nebraska.....	.....	2,500
New Mexico.....	.....	2,000
District of Columbia.....	2,228	2,000
Total.....	78,959	1,855,087

The number of these troops now in service can only be conjectured. It does not probably exceed 900,000.

The following table gives the pay and perquisites of the officers and privates of the regular and volunteer service, both receiving the same pay in their respective grades:

MONTHLY PAY OF NON-COMMISSIONED OFFICERS,  
PRIVATES, &c.

<i>Cavalry.</i>		
Sergeant-Major.....	\$21 00	Corporal..... \$14 00
Quartermaster-Serg't.	31 00	Bugler..... 18 00
Chief Bugler.....	21 00	Farrier and Black-
First Sergeant.....	30 00	smith..... 15 00
Sergeant.....	17 00	Private..... 13 00
<i>Ordnance.</i>		
Sergeant.....	\$34 00	Private, first class.... \$17 00
Corporal.....	30 00	Private, second class. 13 00
<i>Artillery and Infantry.</i>		
Sergeant-Major.....	\$21 00	Artificer, artillery.... \$15 00
Quartermaster-Serg't.	17 00	Private..... 13 00
First Sergeant.....	30 00	Principal musician... 31 00
Sergeant.....	17 00	Musician..... 13 00
Corporal.....	13 00	
<i>Sappers, Minors, and Pontoniers.</i>		
Sergeant.....	\$34 00	Private, second class. \$13 00
Corporal.....	30 00	Musician..... 13 00
Private, first class....	17 00	
<i>Brigade Bands.</i>		
Leader.....	\$45 00	Drum-Major..... \$17 00
Four of the Band....	34 00	Four of the Band.... 30 00
Eight of the Band....	17 00	
Medical Cadets (and 1		Matrons..... \$6 00
ration per day).....	\$30 00	Female Nurses, per
Hospital Stewards....	80 00	day and 1 ration 40
Master Wagoners (3d		cents.
Aug. 1861).....	17 00	Wagoners (Aug. 3, '61) 14 00

124 cents per month is to be retained from the pay of each enlisted man of the army for the support of the "Soldier's Home." \$2 per month is allowed for reenlistment, and \$1 per month additional for each subsequent period of five years' service, provided the enlistment is made within one month after the expiration of each term.

\* Including 15,888 three months' troops in the summer of 1862.

† Including 50,000 volunteers raised to repel the invasion of the State in September, 1862.

‡ Including 16,857 three months' troops furnished in the summer of 1862.

§ Including 4,229 troops raised for short special service.

ARMY OF THE UNITED STATES

19

TABLE OF PAY, SUBSISTENCE, &c., ALLOWED BY LAW TO THE OFFICERS OF THE ARMY.

RANK AND CLASSIFICATION OF OFFICERS.	Pay.	Subsistence.		Servants.		Total monthly pay.	Forage furnished for horses.	
	Per month.	Number of rations per day.	Monthly commutation value.	Number of servants allowed.	Monthly commutation value.		In time of war.	In time of peace.
<i>General Officers.</i>								
Lieutenant-General.....	\$270 00	40	\$360 00	4	\$90 00	\$720 00	And for forage.	\$50
Aides-de-camp and Military Secretary to Lieutenant-General, each.....	80 00	5	45 00	2	45 00	170 00	\$2	2
Major-General.....	220 00	15	185 00	4	90 00	445 00	7	5
Senior Aide-de-camp to General-in-Chief.....	80 00	4	36 00	2	47 00	163 00	4	2
Aide-de-camp, in addition to pay, &c., of Lieutenant.....	24 00	..	..	..	..	24 00	2	2
Brigadier-General.....	124 00	12	108 00	3	67 50	299 50	5	4
Aide-de-camp, in addition to pay, &c., of Lieutenant.....	20 00	..	..	..	..	11 00	2	2
<i>Adjutant-General's Department.</i>								
Adjutant-General—Brigadier-General.....	124 00	12	108 00	3	67 50	299 50	5	4
Assistant Adjutant-General—Colonel.....	110 00	6	54 00	2	47 00	211 00	5	2
Assistant Adjutant-General—Lieutenant-Colonel.....	95 00	5	45 00	2	47 00	187 00	4	2
Assistant Adjutant-General—Major.....	80 00	4	36 00	2	47 00	163 00	4	2
<i>Judge-Advocate-General—Colonel.....</i>								
Judge-Advocate—Major.....	110 00	6	54 00	2	47 00	211 00	5	2
(Division)—Major.....	80 00	4	36 00	2	47 00	163 00	4	2
<i>Inspector-General's Department.</i>								
Inspector-General—Colonel.....	110 00	6	54 00	2	47 00	211 00	5	2
Assistant Inspector-General—Major.....	80 00	4	36 00	2	47 00	163 00	4	2
<i>Signal Department.</i>								
Signal Officer—Major.....	80 00	4	36 00	2	47 00	163 00	4	2
<i>Quartermaster's Department.</i>								
Quartermaster-General—Brigadier-General.....	124 00	12	108 00	3	67 00	299 50	5	4
Assistant Quartermaster-General—Colonel.....	110 00	6	54 00	2	47 00	211 00	5	2
Deputy Quartermaster-General—Lieutenant-Colonel.....	95 00	5	45 00	2	47 00	187 00	4	2
Quartermaster—Major.....	80 00	4	36 00	2	47 00	163 00	4	2
Assistant Quartermaster—Captain.....	70 00	4	36 00	1	23 50	129 50	3	2
<i>Subsistence Department.</i>								
Commissary-General of Subsistence—Colonel.....	110 00	6	54 00	2	47 00	211 00	5	2
Assistant Commissary-General of Subsistence—Lt.-Col.....	95 00	5	45 00	2	47 00	187 00	4	2
Commissary of Subsistence—Major.....	80 00	4	36 00	2	47 00	163 00	4	2
Commissary of Subsistence—Captain.....	70 00	4	36 00	1	23 50	129 50	3	2
Assistant Commissary of Subsistence, in addition to pay, &c., of Lieutenant.....	20 00	..	..	..	..	11 00	..	..
<i>Medical Department.</i>								
Surgeon-General—Brigadier-General.....	124 00	12	108 00	3	67 50	299 50	5	4
Surgeons of ten years' service.....	80 00	8	72 00	2	47 00	199 00	4	2
Surgeons of less than ten years' service.....	50 00	4	36 00	2	47 00	163 00	4	2
Assistant Surgeons of ten years' service.....	70 00	8	72 00	1	23 50	165 50	3	2
Assistant Surgeons of five years' service.....	70 00	4	36 00	1	23 50	129 50	3	2
Assistant Surgeons of less than five years' service.....	58 33	4	36 00	1	23 50	112 83	2	2
<i>Pay Department.</i>								
Paymaster-General, \$2,740 per annum.....	..	..	..	..	..	288 33	..	..
Deputy Paymaster-General.....	95 00	5	45 00	2	47 00	187 00	4	2
Paymaster.....	80 00	4	36 00	2	47 00	163 00	4	2
<i>Officers of the Corps of Engineers, Corps of Topographical Engineers, and Ordnance Department.</i>								
Chief of Ordnance—Brigadier-General.....	124 00	12	108 00	3	67 50	299 50	5	4
Colonel.....	110 00	6	54 00	2	47 00	211 00	5	2
Lieutenant-Colonel.....	95 00	5	45 00	2	47 00	187 00	4	2
Major.....	80 00	4	36 00	2	47 00	163 00	4	2
Captain.....	70 00	4	36 00	1	23 50	129 50	3	2
First Lieutenant.....	58 33	4	36 00	1	23 50	112 83	2	2
Second Lieutenant.....	58 33	4	36 00	1	23 50	112 83	2	2
Brevet Second Lieutenant.....	58 33	4	36 00	1	23 50	112 83	2	2
<i>Officers of Mounted Dragoons, Cavalry, Riflemen, and Light Artillery.</i>								
Colonel.....	110 00	6	54 00	2	47 00	211 00	5	2
Lieutenant-Colonel.....	95 00	5	45 00	2	47 00	187 00	4	2
Major.....	80 00	4	36 00	2	47 00	163 00	4	2
Captain.....	70 00	4	36 00	1	23 50	129 50	3	2
First Lieutenant.....	58 33	4	36 00	1	23 50	112 83	2	2
Second Lieutenant.....	58 33	4	36 00	1	23 50	112 83	2	2
Brevet Second Lieutenant.....	58 33	4	36 00	1	23 50	112 83	2	2
Adjutant, in addition to pay of Lieutenant.....	10 00	..	..	..	..	10 00	..	..
Regimental Quartermaster, in addition to pay of Lieut.....	10 00	..	..	..	..	10 00	..	..
<i>Officers of Artillery and Infantry.</i>								
Colonel.....	95 00	6	54 00	2	45 00	194 00	4	2
Lieutenant-Colonel.....	80 00	5	45 00	2	45 00	170 00	3	2
Major.....	70 00	4	36 00	2	45 00	151 00	3	2
Captain.....	60 00	4	36 00	1	22 50	118 50	..	..
First Lieutenant.....	50 00	4	36 00	1	22 50	108 50	..	..
Second Lieutenant.....	45 00	4	36 00	1	22 50	103 50	..	..
Brevet Second Lieutenant.....	45 00	4	36 00	1	22 50	103 50	..	..
Adjutant, in addition to pay, &c., of Lieutenant.....	10 00	..	..	..	..	10 00	2	2
Regiml Quartermaster, in addition to pay, &c., of Lt.....	10 00	..	..	..	..	10 00	2	2



Storekeepers attached to the quartermaster's department; at armories, and at arsenals of construction; the storekeeper at Watertown arsenal, and storekeepers of ordnance serving in Oregon, California, and New Mexico, receive \$1,490 per annum; at all other arsenals, \$1,040 per annum.

Chaplains are paid \$100 per month, 2 rations per day, or \$18 per month commutation value; and in time of war or peace \$1 per month is allowed for forage; total, \$119.

Paymasters' clerks receive \$700 per annum, and one ration (75 cents) per day when on duty.

The officer in command of a company is allowed \$10 per month for the responsibility of clothing, arms, and accoutrements.—Act March 2, 1827, Sec. 2.

Subaltern officers, employed on the general staff, and receiving increased pay therefor, are not entitled to the additional or fourth ration provided by the Act March 2, 1827, Sec. 2.

Every commissioned officer below the rank of brigadier-general receives one additional ration per day for every five years' service.—Act July 5, 1836, Sec. 12; and July 7, 1838, Sec. 9.

In suddenly calling such vast numbers of men into the field, the industrial energies of the Northern States were aroused to prepare them for an active campaign. While the generals were engaged in organizing and disciplining these forces, the Government was preparing for their equipment. Their clothing was of a uniform material, which was made up in every part of the loyal States. The personal outfit of the soldiers was very complete. The arms were in part manufactured in the country, and partly imported from Europe. The supply of artillery in the country was also so small that it was not only manufactured to the utmost extent practicable, but also imported from Europe. The harness for the horses in every variety of the service, and the materials of which it was composed, and the equipments for the large force of cavalry, were not in existence, and could be obtained only by manufacture and importation. The thousands of wagons required existed only in the form of rough wood and bars of iron. The tents of the soldiers demanded for their manufacture the active efforts of those heretofore employed to make the sails for ships. These demands exposed the unprepared condition of the country for a great war, and delayed the period of active operations. The abundant resources of the Northern States, however, enabled them to fit out their troops with a profuseness that was burdensome, and interfered to some extent with military success.

From a careful investigation and comparison of the monthly "casualty returns" made to the office of the adjutant-general, it is calculated that the number of deaths in the volunteer force of the United States in active service has been at the annual ratio of 58.2 per thousand men, of which 44.6 were from disease and accident, and 8.6 from wounds received in action. Some

defects and omissions in the regimental returns render it probable that this may be an understatement, as the data do not include deaths among those discharged from or otherwise quitting the service. An allowance, however, was made for this defect.

Assuming that the rate of mortality experienced by those who quit the service (by discharge for disability, desertion, or otherwise) is the same as those continuing in the service, to wit, 58.2 per 1,000—a very moderate estimate, since those discharged for disability are justly presumed to be at the time, in point of health, inferior to their comrades who remain—the actuary of the Sanitary Commission, reckons the annual rate of deaths at about 65 per 1,000.

It appears from the returns, that while the death-rate from wounds in action is greater in the case of officers than of privates, being respectively  $11\frac{1}{2}$  and  $8\frac{1}{2}$  per 1,000, the death-rate of officers from disease and accident is much less than of privates—22 for the former to 46 for the latter—and that the rate from all causes, embracing both disease and violence, is less with the officers than with the men—the entire rate for officers being 33, and for men 54 per 1,000.

The excess of the mortality due to disease and accident, over that due to wounds in action, is a noticeable fact in the volunteer army of the United States, as in all other armies—two thirds of the deaths of the officers and five sixths of those of the men resulting from disease and accident; the remaining one third and one sixth, respectively, being caused by wounds received in battle.

It appears from the returns that the general mortality of the army has been gradually increasing since the commencement of the war, and that the rate for the autumnal months is 1.7 times that indicated by the returns for the summer period, and the winter rate in turn double 1.9 times that of autumn.

It is also observed that the mortality of the armies recruited at the West, and which operate at the West, is 3.01 times that of the troops recruited in the Middle and New England States, and which serve in the armies at the East; the Western rate from wounds received in action being 4.9 times, and that from disease and accident 2.8 times as great as the corresponding rates in the East.

To supply losses among the enlisted men in the Eastern armies requires recruits at the rate of 18.8 per 1,000 per month, or 226 per 1,000 per annum; of which latter proportion 32 is the number required to supply the annual loss by death; 100 the annual loss by discharge from service, chiefly from disability; 79 the annual loss from missing in action and from desertions; and 15 to supply the loss from other causes.

To supply such losses in the Western armies requires recruits at the rate of 19.5 per 1,000 per month, or 184 per 1,000 per annum; of which latter proportion 96 are required to

supply the annual loss from deaths; 101 the loss from discharges from service, mainly from disability; 35 the loss from missing in action and from desertions, and 2 from other causes.

The number of "missing" and of "deserters" in the Eastern volunteer army is more than double the number of those classes in the Western volunteer forces.

Taking the returns of the period from the 1st of June, 1861, to the 1st of March, 1862, as the basis of calculation, it is estimated that to secure in the field a constant force of 500,000 effective men, the nation must not only maintain 58,000 sick men, but must also recruit the ranks of the enlisted portion of these forces with new material at the rate of 128,000 per annum so long as the war shall last—a rate somewhat exceeding 10,000 recruits per month. Of those 128,000 annual recruits 88,000 are to supply losses by death and discharges from service (exclusive of discharges for expiration of term of enlistment); 84,000 for desertions and missing in action; and 6,000 to supply other losses specified and unspecified.

The desertions from the army in the autumn of 1862 became so great as to cause the appointment of officers to arrest and return such persons. An order of Gen. Buell, dated near Florence, Alabama, on June 24, stated that 14,000 officers and soldiers were absent from the various divisions of his army. Some had gone without any authority, and others with the permission of officers not authorized to grant it. Sickness was generally stated to be the cause of this absence, but in many cases it had notoriously ceased to exist. In September the War Department issued the following order:

*Orders respecting Special Provost Marshals, and defining their duties.*

WAR DEPARTMENT, ADJUTANT-GENERAL'S OFFICE, }  
WASHINGTON, Sept. 24, 1862. }

*First.* There shall be a Provost Marshal General of the War Department, whose headquarters will be at Washington, and who will have the immediate supervision, control, and management of the corps.

*Second.* There will be appointed in each State one or more Special Provost Marshals, as necessity may require, who will report to, and receive instructions and orders from the Provost Marshal General of the War Department.

*Third.* It will be the duty of the Special Provost Marshals to arrest all deserters, whether regulars, volunteers, or militia, and send them to the nearest military commander, or military post, where they can be cared for and sent to their respective regiments; to arrest, upon the warrant of the Judge Advocate, all disloyal persons subject to arrest under the orders of the War Department; to inquire into and report treasonable practices, seize stolen or embezzled property of the Government, detect spies of the enemy, and perform such other duties as may be enjoined upon them by the War Department; and report all their proceedings promptly to the Provost Marshal General.

*Fourth.* To enable Special Provost Marshals to discharge their duties efficiently, they are authorized to call on any available military force within their respective districts, or else to employ the assistance of citizens, constables, sheriffs, or police officers, so far as may be necessary under such regulations as may be prescribed by the Provost Marshal General of the War

Department with the approval of the Secretary of War.

*Fifth.* Necessary expenses incurred in this service will be paid on duplicate bills certified by the Special Provost Marshals, stating the time and nature of the service, after examination and approval by the Provost Marshal General.

*Sixth.* The compensation of Special Provost Marshals will be \_\_\_\_\_ dollars per month, and actual travelling expenses and postage will be refunded on bills certified to under oath and approved by the Provost Marshal General.

*Seventh.* All appointments in this service will be subject to be revoked, at the pleasure of the Secretary of War.

*Eighth.* All orders heretofore issued by the War Department, conferring authority upon other officers to act as Provost Marshals (except those who have received special commissions from the War Department), are hereby revoked.

By order of the Secretary of War,

J. THOMAS, Adjutant-General.

The operations for the surgical department have been aided by humane and benevolent associations. The horrors of battle have been assuaged by ministers of mercy, and the services of the medical profession have been voluntarily and gratuitously offered on every occasion. Relief associations in every State have done much to comfort and assist the sick and wounded in camps and hospitals, and their vigilant superintendence has perhaps operated to check the negligence, abuse, and fraud that too often prevail even in such institutions. Religious congregations and societies have also tendered to the Government their church buildings for hospitals, while their pastors have ministered to the patients.

The subsistence of the armies during the year has been reported as good and wholesome. Fresh beef has generally been supplied to the armies in the field on the hoof, to lessen, as far as possible, the quantity of transportation required, and in larger proportion of the ration to marching columns. The troops on the coasts of the Carolinas, and at the Gulf posts, including New Orleans, received their fresh beef by shipment from New York. In addition to the troops, subsistence has been furnished to all political prisoners and prisoners of war, to a large number of contrabands, and to the suffering Union inhabitants found in the march of armies in the Confederate States. It is stated by the general-in-chief—Halleck—that no armies in the world are so well supplied as the armies of the United States.

Notwithstanding the extraordinary demand for arms occasioned by the new levies, and the enormous losses occasioned by the casualties of war, and, in some instances, by the misconduct of officers and men, over four hundred thousand new troops suddenly called into the field were supplied at once. The issues from the ordnance department include 1,926 field and siege, and 1,206 fortification cannon, 7,294 gun carriages, caissons, mortar beds, travelling forges and battery wagons; 1,276,686 small arms, 987,291 sets of equipment and accoutrements, and 218,991,127 rounds of ammunition for artillery and small arms.

ARMY OF THE UNITED STATES.

GENERAL OFFICERS OF THE REGULAR ARMY OF THE UNITED STATES.

Officers not thus \* designated are graduates of the Military Academy.

NAME.	Rank.	Date of commission.	Brevets and former commissions.	Entry into service.	Born in	Appointed from
George B. McClellan.....	Maj.-Gen.	May 14, 1861.		July 1, 1846.	Penn.	Ohio.
John O. Fremont*.....	do.	May 14, 1861.		July 7, 1839.	S. C.	Cal.
Henry W. Halleck.....	do.	Aug. 19, 1861.	Commanding army.	July 1, 1839.	N. Y.	Cal.
John E. Wool*.....	do.	May 16, 1862.	Brevet February 23, 1847.	April 14, 1819.	N. Y.	N. Y.
William S. Harney*.....	Brig.-Gen.	June 14, 1858.	Brevet April 18, 1847.	Feb. 13, 1818.	La.	La.
Edwin V. Sumner*.....	do.	March 16, 1861.	{ M.-G. brt. May 31, 1847. M.-G. vol., July 4, 1862. }	March 3, 1819.	Mass.	N. Y.
Irvin McDowell.....	do.	May 14, 1861.	M.-G. vol. March 14, 1862.	July 1, 1833.	Ohio.	Ohio.
Robert Anderson.....	do.	May 15, 1861.		July 1, 1825.	Ky.	Ky.
William B. Rosserans.....	do.	May 16, 1861.		July 1, 1842.	Ohio.	Ohio.
Phillip St. G. Cooke.....	do.	Nov. 12, 1861.		July 1, 1827.	Va.	Va.
Joseph Hooker.....	do.	July 4, 1862.	M.-G. vol. July 4, 1862.			
John Pope.....	do.	July 14, 1862.	M.-G. vol. March 21, 1863.	July 1, 1842.	Ky.	Ill.

VOLUNTEER SERVICE—GENERAL OFFICERS APPOINTED UNDER ACT OF CONGRESS, DEC. 1863.

NAME, RANK, AND DATE OF COMMISSION.			Born in	Appointed from	NAME, RANK, AND DATE OF COMMISSION.			Born in	Appointed from
<i>Major-Generals.</i>									
Nathaniel P. Banks*.....	May 16, 1861.	Mass.	Mass.	James S. Wadsworth*.....	August 9, 1861.	N. Y.	N. Y.		
John A. Dix*.....	May 16, "	N. H.	N. Y.	John H. Martindale.....	August 9, "	N. Y.	N. Y.		
Benjamin F. Butler*.....	May 16, "	N. H.	Mass.	Samuel D. Sturgis.....	August 10, "	Penn.	Penn.		
David Hunter.....	August 13, "	D. C.	Illinois.	George Stoneman.....	August 13, "	N. Y.	N. Y.		
Edwin D. Morgan*.....	Sept. 23, "	Mass.	N. Y.	James W. Denver*.....	August 14, "	Va.	Cal.		
Ethan A. Hitchcock.....	Feb. 10, 1862.	Vt.	Missouri.	Egbert L. Viele.....	August 17, "	N. Y.	N. Y.		
Ulysses S. Grant.....	Feb. 16, "	Ohio.	Ohio.	James Shields.....	August 19, "	Ireland.	Cal.		
Irvin McDowell.....	March 14, "	Ohio.	Ohio.	William F. Barry.....	August 20, "	N. Y.	N. Y.		
Ambrose E. Burnside.....	March 18, "	Ind.	E. I.	John J. Abercrombie.....	August 21, "	Tenn.	Tenn.		
Don Carlos Buell.....	March 21, "	Ohio.	Indiana.	Silas Casey.....	August 21, "	R. I.	E. I.		
John Pope.....	March 21, "	Ky.	Illinois.	Lawrence P. Graham*.....	August 21, "	Va.	Va.		
Samuel R. Curtis.....	March 21, "	N. Y.	Iowa.	George G. Meade.....	August 21, "	Spain.	D. C.		
Franz Sigel*.....	March 21, "	Germ'y	Missouri.	Abram Duryee*.....	August 21, "	N. Y.	N. Y.		
John A. McClernand*.....	March 21, "	Ky.	Illinois.	Oliver O. Howard.....	Sept. 3, "	Maine.	Maine.		
Lewis Wallace*.....	March 21, "	Ind.	Indiana.	Eleazer Paine.....	Sept. 3, "	Ohio.	Illinois.		
William S. Rosserans.....	March 21, "	Ohio.	Ohio.	Daniel E. Stickles*.....	Sept. 3, "	N. Y.	N. Y.		
Cassius M. Clay*.....	April 11, "	Ky.	Kent'y.	Kbenazer Dumont*.....	Sept. 3, "	Ind.	Indiana.		
George H. Thomas.....	April 25, "	Va.	Virginia.	Robert H. Milroy*.....	Sept. 3, "	Ind.	Indiana.		
George Cadwalader*.....	April 25, "	Penn.	Penn.	Willis A. Gorman*.....	Sept. 7, "	Ky.	Minn.		
John G. Foster.....	April 26, "	N. H.	N. H.	Daniel Butterfield*.....	Sept. 7, "	N. Y.	N. Y.		
John G. Parks.....	April 26, "	Penn.	Penn.	W. T. Ward*.....	Sept. 18, "	Ky.	Ky.		
William T. Sherman.....	May 1, "	Ohio.	Ohio.	John G. Bernard.....	Sept. 23, "	Mass.	Mass.		
Edward O. C. Ord.....	May 2, "	Md.	D. C.	Innis N. Palmer.....	Sept. 23, "	N. Y.	N. Y.		
Edwin V. Sumner*.....	July 4, "	Mass.	N. Y.	Beth Williams.....	Sept. 23, "	Maine.	Maine.		
Samuel P. Heintzelman.....	July 4, "	Penn.	Penn.	John Newton.....	Sept. 23, "	Va.	Va.		
Erasmus D. Keyes.....	July 4, "	Mass.	Maine.	Winfield S. Hancock.....	Sept. 23, "	Penn.	Penn.		
William B. Franklin.....	July 4, "	Penn.	Penn.	Randolph B. Marcy.....	Sept. 23, "	Mass.	Mass.		
Joseph Hooker.....	July 4, "	Mass.	Cal.	George Wright.....	Sept. 23, "	Vt.	Vt.		
Darius M. Couch.....	July 4, "	N. Y.	Mass.	George Sykes.....	Sept. 23, "	Md.	Maryl'd.		
Henry W. Slocum.....	July 4, "	N. Y.	N. Y.	William W. Burns.....	Sept. 23, "	Ohio.	Ohio.		
John J. Peck.....	July 4, "	N. Y.	N. Y.	William H. French.....	Sept. 23, "	Md.	D. C.		
George W. Morrell.....	July 4, "	N. Y.	N. Y.	William T. H. Brooks.....	Sept. 23, "	Ohio.	Ohio.		
William F. Smith.....	July 4, "	Vt.	Vt.	John M. Brannan.....	Sept. 23, "	D. C.	Indiana.		
John Sedgwick.....	July 4, "	Conn.	Conn.	John P. Hatch.....	Sept. 23, "	N. Y.	N. Y.		
Alex. McD. McCook.....	July 17, "	Ohio.	Ohio.	David S. Stanley.....	Sept. 23, "	Ohio.	Ohio.		
Thos. L. Ottendene*.....	July 17, "	Ky.	Ky.	William K. Strong*.....	Sept. 23, "	N. Y.	N. Y.		
Horatio G. Wright.....	July 19, "	Conn.	Conn.	Albin Schoepf*.....	Sept. 30, "	Hung'y	Maryl'd.		
Gordon Granger.....	Sept. 17, "	N. Y.	N. Y.	James S. Negley*.....	Octob'r 1, "	Penn.	Penn.		
Stephen H. Hurlbut*.....	Sept. 17, "	S. C.	Illinois.	Francis B. Spinola.....	Octob'r 1, "	N. Y.	N. Y.		
Robert C. Schenck.....	August 30, "	Ohio.	Ohio.	Thomas J. Wood.....	Octob'r 11, "	Ky.	Ky.		
Schuyler Hamilton.....	Sept. 17, "	N. Y.	N. Y.	Richard W. Johnson.....	Octob'r 11, "	Ky.	Ky.		
J. D. Cox*.....	Octob'r 6, "	Canada.	Ohio.	A. Von Steinwehr*.....	Octob'r 12, "	Germ'y	N. Y.		
James B. McPherson.....	Octob'r 8, "	Ohio.	Ohio.	George W. Cullum.....	Nov. 1, "	N. Y.	Penn.		
Lovell H. Rousseau.....	Octob'r 8, "	Ky.	Ky.	Jeremiah T. Boyle.....	Nov. 9, "	N. Y.	Ky.		
Christopher C. Augur.....	Nov. 14, "	N. Y.	Mich.	Jullus H. Stahl*.....	Nov. 12, "	Hung'y	N. Y.		
J. F. Reynolds.....	Dec. —, "	Penn.	Penn.	George W. Morgan*.....	Nov. 19, "		Ohio.		
<i>Brigadier-Generals.</i>									
Andrew Porter*.....	May 17, 1861.	Penn.	Penn.	John M. Schofield.....	Nov. 21, "	N. Y.	Illinois.		
Charles P. Stone.....	May 17, "	Mass.	D. C.	Thomas J. McKean.....	Nov. 21, "	Penn.	Penn.		
Thomas W. Sherman.....	May 17, "	R. I.	R. I.	Zealous B. Tower.....	Nov. 23, "	Mass.	Mass.		
George A. McCall.....	May 17, "	Penn.	Penn.	Jefferson C. Davis*.....	Dec. 18, "	Ind.	Indiana.		
Wm. R. Montgomery.....	May 17, "	N. J.	N. J.	John M. Palmer*.....	Dec. 20, "	Ky.	Illinois.		
John W. Phelps.....	May 17, "	Vt.	Vt.	James H. Garfield*.....	Jan. 11, 1862.	Ohio.	Ohio.		
Charles S. Hamilton.....	May 17, "	N. Y.	Wis.	Lewis G. Arnold.....	Jan. 24, "	N. J.	N. J.		
Rufus King.....	May 17, "	N. Y.	Wis.	Frederick Steele.....	Jan. 29, "	N. Y.	N. Y.		
B. M. Prentiss*.....	May 17, "	Va.	Illinois.	William S. Ketohum.....	Feb. 3, "	Conn.	Conn.		
Benjamin F. Kelley*.....	May 17, "	N. H.	Virginia.	Abner Doubleday.....	Feb. 3, "	N. Y.	N. Y.		
A. S. Williams*.....	May 17, "	Conn.	Mich.	John W. Davidson.....	Feb. 3, "	Va.	Va.		
James Cooper*.....	May 17, "	Md.	Md.	Napoleon J. T. Dana.....	Feb. 3, "	Maine.	Minn.		
James B. Eicketts.....	July 21, "	N. Y.	N. Y.	David D. Birney*.....	Feb. 3, "	Ala.	Penn.		
Orlando B. Wilcox.....	July 21, "	Mich.	Mich.	T. Francis Meagher*.....	Feb. 3, "	Ireland.	N. Y.		
Michael Corcoran.....	July 21, "	Ireland.	N. Y.	Henry M. Nagle.....	Feb. 4, "	Penn.	Penn.		
Henry H. Lockwood.....	August 3, "	Del.	Del.	James G. Spears*.....	March 5, "	Tenn.	Tenn.		
Louis Blenker*.....	August 9, "	Germ'y	N. Y.	Eugene A. Carr.....	March 7, "	N. Y.	N. Y.		
				Thomas A. Davies.....	March 7, "	N. Y.	N. Y.		
				Daniel Tyler.....	March 13, "	Conn.	Conn.		
				William H. Emory.....	March 17, "	Md.	Maryl'd.		

VOLUNTEER SERVICE.—Continued.

NAME, RANK, AND DATE OF COMMISSION.			Born in	Appointed from	NAME, RANK, AND DATE OF COMMISSION.			Born in	Appointed from
<i>Brigadier-Generals.—Continued.</i>									
Andrew J. Smith	March 17, 1862	Penn.	Penn.	Green Clay Smith	June 11, 1862	June 11, 1862	Ky.		
Marcus E. Patrick	March 17, "	N. Y.	N. Y.	William B. Campbell	June 30, "	June 30, "	Tenn.		
Isaac F. Quinby	March 17, "	N. J.	N. Y.	Phillip H. Sheridan	July 1, "	July 1, "	Mass.		
Hiram G. Berry	March 17, "	Maine.	Maine.	Benjamin S. Roberts	July 16, "	July 16, "	Vt.		
Orris S. Ferry	March 17, "	Conn.	Conn.	Alfred Pleasanton	July 16, "	July 16, "	D. C.		
Daniel P. Woodbury	March 19, "	N. H.	N. Y.	Jacob Ammen	July 16, "	July 16, "	Va.		
Henry M. Juda	March 21, "	Md.	N. Y.	C. P. Buckingham	July 16, "	July 16, "	Ohio.		
John Cook	March 21, "	Ill.	Illinois.	Fitz-Henry Warren	July 16, "	July 16, "	Mass.		
John McArthur	March 21, "	Scott'd.	Illinois.	Morgan L. Smith	July 16, "	July 16, "	N. Y.		
Jacob G. Lanman	March 21, "	Md.	Iowa.	Charles Cruft	July 16, "	July 16, "	Ind.		
Horatio P. Van Cleave	March 21, "	Ill.	Minn.	Frederick Salmon	July 16, "	July 16, "	Prussia.		
John A. Logan	March 21, "	Ill.	Illinois.	Cad. C. Washburne	July 16, "	July 16, "	Maine.		
Speed S. Fry	March 21, "		Ky.	Francis J. Herron	July 16, "	July 16, "	Penn.		
Alexander Asboth	March 21, "			John Cochrane	July 17, "	July 17, "	N. Y.		
James Crate	March 21, "	Penn.	Missouri.	John B. Turchin	July 17, "	July 17, "	Russia.		
Mahlon D. Manson	March 24, "	Ohio.	Indiana.	Henry S. Briggs	July 17, "	July 17, "	Mass.		
Edward E. S. Canby	March 31, "	Ky.	Indiana.	James D. Morgan	July 17, "	July 17, "	Illinois.		
Greville M. Dodge	March 31, "	Mass.	Iowa.	August Willich	July 17, "	July 17, "	Prussia.		
Robert B. Mitchell	April 8, "	Ohio.	Kansas.	Henry D. Terry	July 17, "	July 17, "	Conn.		
James G. Blunt	April 8, "	Maine.	Kansas.	James Steedman	July 17, "	July 17, "	Ohio.		
Amiel W. Whipple	April 14, "	Mass.	Mass.	George F. Shepley	July 18, "	July 18, "	Maine.		
Cavler Grover	April 14, "	Maine.	Maine.	John Buford	July 27, "	July 27, "	Ky.		
George L. Hartuff	April 15, "	N. Y.	Mich.	Frank P. Blair	August 7, "	August 7, "	Missouri.		
Rufus Baxton	April 15, "	Mass.	Mass.	Richard Busted	August 7, "	August 7, "	Ireland.		
Benjamin Alvord	April 15, "	Vt.	Vt.	John R. Kenly	August 22, "	August 22, "	Md.		
Napoleon B. Buford	April 15, "	Ky.	Illinois.	John P. Slough	August 25, "	August 25, "	Ohio.		
William S. Smith	April 15, "	Ohio.	Ohio.	Godfrey Weitzel	August 29, "	August 29, "	Ohio.		
Nathan Kimball	April 15, "	Ind.	Indiana.	Gabriel R. Paul	Sept. 5, "	Sept. 5, "	Mo.		
Charles Devens	April 15, "	Mass.	Mass.	Hermann Haupt	Sept. 5, "	Sept. 5, "	Penn.		
James H. Van Alen	April 15, "	N. Y.	N. Y.	Charles E. Hovey	Sept. 5, "	Sept. 5, "	Vt.		
Carl Schurz	April 15, "	N. Y.	Wis.	Thomas L. Kane	Sept. 7, "	Sept. 7, "	Penn.		
Samuel W. Crawford	April 25, "	Penn.	Penn.	Geraham Mott	Sept. 7, "	Sept. 7, "	N. J.		
Henry W. Weasels	April 25, "	Conn.	Conn.	George Crook	Sept. 7, "	Sept. 7, "	Ohio.		
Milo S. Haakell	April 25, "	N. Y.	Indiana.	Joseph B. Carr	Sept. 7, "	Sept. 7, "	N. Y.		
Leonard F. Ross	April 25, "	Ill.	Illinois.	Nelson Taylor	Sept. 7, "	Sept. 7, "	Conn.		
John W. Geary	April 25, "	Penn.	Penn.	J. G. Reynolds	Sept. 7, "	Sept. 7, "	Ky.		
Alfred H. Terry	April 25, "	Conn.	Conn.	Charles C. Gilbert	Sept. 9, "	Sept. 9, "	Ohio.		
Andrew A. Humphrey	April 28, "	Penn.	D. C.	Edward Ferrero	Sept. 10, "	Sept. 10, "	Spain.		
James H. Carleton	April 28, "	Maine.	Maine.	James Nagle	Sept. 10, "	Sept. 10, "	Penn.		
Abraham Baird	April 28, "	Penn.	Penn.	Calvin E. Pratt	Sept. 10, "	Sept. 10, "	Mass.		
John C. Robinson	April 28, "	N. Y.	N. Y.	Henry J. Hunt	Sept. 15, "	Sept. 15, "	Mich.		
Truman Seymour	April 28, "	Vt.	Vt.	Francis L. Vinton	Sept. 19, "	Sept. 19, "	Maine.		
Quincy A. Gillmore	April 28, "	Ohio.	Ohio.	Gustavus A. Smith	Sept. 19, "	Sept. 19, "	Ohio.		
Henry Princes	April 28, "	Maine.	Maine.	Francis C. Barlow	Sept. 19, "	Sept. 19, "	N. Y.		
Abraham S. Platt	April 28, "	Ohio.	Ohio.	N. J. Jackson	Sept. 24, "	Sept. 24, "	Mass.		
Thomas T. Crittenden	April 28, "	Ala.	Indiana.	Mason Brayman	Sept. 24, "	Sept. 24, "	N. Y.		
Max Weber	April 28, "		N. Y.	Geo. W. Getty	Sept. 25, "	Sept. 25, "	D. C.		
Jeremiah C. Sullivan	April 28, "			Gouv. K. Warren	Sept. 26, "	Sept. 26, "	N. Y.		
Alvin P. Hovey	April 28, "	Ind.	Indiana.	Alfred Sully	Sept. 26, "	Sept. 26, "	Penn.		
James C. Veatch	April 28, "	Ind.	Indiana.	Wm. W. Averill	Sept. 26, "	Sept. 26, "	N. Y.		
William P. Benton	April 28, "	Md.	Indiana.	Robert W. Cowdin	Sept. 26, "	Sept. 26, "	Vt.		
John C. Caldwell	April 28, "	Vt.	Maine.	Henry H. Sibley	Sept. 29, "	Sept. 29, "	Mich.		
Neal Dow	April 28, "	Maine.	Maine.	Alexander Hays	Sept. 29, "	Sept. 29, "	Penn.		
George S. Greene	April 28, "	R. I.	N. Y.	John H. H. Ward	Octob'r 4, "	Octob'r 4, "	N. Y.		
Samuel P. Carter	May 1, "	Tenn.	Tenn.	John M. Thayer	Octob'r 4, "	Octob'r 4, "	Mass.		
John Gibbon	May 9, "	Penn.	N. C.	J. J. Bartlett	Octob'r 4, "	Octob'r 4, "	N. Y.		
Emastus B. Tyler	May 14, "	N. Y.	Ohio.	Solomon Meredith	Octob'r 6, "	Octob'r 6, "	N. C.		
Charles Griffin	June 9, "	Ohio.	Ohio.	James Bowen	Octob'r 11, "	Octob'r 11, "	N. Y.		
George H. Gordon	June 9, "	Mass.	Mass.	Gustave P. Cluseret	Octob'r 14, "	Octob'r 14, "	France.		
James M. Tuttle	June 9, "	Ohio.	Iowa.	Eliakim P. Scammon	Octob'r 15, "	Octob'r 15, "	Maine.		
Julius White	June 9, "	N. Y.	Illinois.	Robert S. Granger	Octob'r 20, "	Octob'r 20, "	Ohio.		
Peter J. Osterhaus	June 9, "	Prussia.	Missouri.	Joseph E. West	Octob'r 25, "	Octob'r 25, "			
Stephen G. Burbridge	June 9, "	Ky.	Ky.	Joseph W. Revere	Octob'r 25, "	Octob'r 25, "			
Washington L. Elliott	June 11, "	Penn.	Penn.	Alfred W. Elliot	Nov. 1, "	Nov. 1, "	Penn.		
Albion P. Howe	June 11, "	Maine.	Maine.	E. N. Stoughton	Nov. 5, "	Nov. 5, "			
				Geo. L. Andrews	Nov. 10, "	Nov. 10, "	Mass.		

*Casualties in the Volunteer Force.*—Maj.-Gen. Charles F. Smith, at Savannah, Tenn., April 25, 1862.  
 Maj.-Gen. O. M. Mitchell, at Beaufort, S. C., Oct. 30, 1862.  
 Maj.-Gen. Israel B. Richardson, of wounds received at the battle of Antietam, at Harper's Ferry, November 4, 1862.  
 Maj.-Gen. Philip Kearney, of New Jersey, killed at the battle of Chantilly, Va., September 1, 1862.  
 Maj.-Gen. Jesse L. Reno, of Massachusetts, killed at the battle of Catochtin, Md., September 14, 1862.  
 Maj.-Gen. William Nelson, of Kentucky, killed in a personal rencontre at Louisville, September 29, 1862.  
 Brig.-Gen. F. W. Lander, at Camp Chase, Va., March 2, 1862.  
 Brig.-Gen. Wm. H. Keim, at Harrisburg, Pa., May 18, 1862.  
 Brig.-Gen. William H. L. Wallace, at Savannah, Tenn., of wounds received at the battle of Shiloh, Tenn., April 10, 1862.  
 Brig.-Gen. Nathaniel Lyon, of Connecticut, killed at the battle of Wilson's Creek, Mo., August 10, 1861.  
 Brig.-Gen. Thomas Williams, of Michigan, killed at the battle of Baton Rouge, La., August 5, 1862.  
 Brig.-Gen. Robert L. McCook, of Ohio, shot by guerillas in northern Alabama, August 6, 1862.  
 Brig.-Gen. Joseph B. Plummer, of Missouri, at Camp Gaylord, Miss., August 9, 1862.

Brig.-Gen. Henry Bohlen, of Pennsylvania, killed on the Rappahannock, Va., August 23, 1862.  
 Brig.-Gen. George W. Taylor, of New Jersey, killed at the second battle of Bull Run, Va., August 31, 1862.  
 Brig.-Gen. Isaac I. Stevens, of Washington Territory, killed at the battle of Chantilly, Va., September 1, 1862.  
 Brig.-Gen. Joseph K. F. Mansfield, died at the battle of Antietam, Md., September 18, 1862.  
 Brig.-Gen. Isaac P. Rodman, of R. I., died at Hagerstown, Md., Sept. 29, of wounds received at the battle of Antietam.  
 Brig.-Gen. Pleasant A. Hackleman, of Indiana, killed at the battle of Corinth, Miss., October 4, 1862.  
 Brig.-Gen. James S. Jackson, of Kentucky, killed at the battle of Perryville, Ky., October 8, 1862.  
 Brig.-Gen. Wm. R. Terrill, of Va. (Captain Fifth U. S. Artillery), killed at the battle of Perryville, Ky., Oct. 8, 1862.  
 Brig.-Gen. F. E. Patterson, at Fairfax, Va., Nov. 22, 1862.  
 Brig.-Gen. Richard J. Olesby, of Michigan, at the battle of Perryville, Ky., October 8, 1862.  
 Brig.-Gen. George D. Bayard, of New Jersey, at the battle of Fredericksburg, Va., December 13, 1862.  
 Brig.-Gen. Joshua W. Bill, of Ohio, at the battle of Murfreesborough, December 31, 1862.

**ARMY OPERATIONS.** At the commencement of the year 1862, the position of the Federal forces was as follows: At Fortress Monroe and Newport News under the command of General Wool, there were estimated to be 15,000 men in a good state of organization and discipline. Thence proceeding up the Potomac, Gen. Hooker's division, including Gen. Sickles's brigade, was south of Washington, and partly on the Maryland side of the Potomac. They numbered about 10,000 men. Southwest of Washington, and in the neighborhood of that city, was the mass of Gen. McClellan's army, consisting of a large portion of the men who had volunteered from the middle and eastern States, for the war. They were organized into eight divisions, and becoming disciplined for future operations. The divisions of Gens. Keyes and Casey were in and around Washington, that of Gen. Stone was at and near Poolesville, and that of Gen. Banks near Darnestown, with detachments on the Potomac to Williamsport. The entire force thus organized, was not far from 160,000 men, which, in connection with other troops on the line of railroad to Baltimore, at that city, and in the vicinity, was something less than 200,000 men. This force before Washington was subsequently designated as the Army of the Potomac. It was organized into divisions, each commanded by a major-general, or by a brigadier-general acting as a major-general; and each division consisted of three brigades, each brigade of four, a few of five, regiments of infantry, making twelve infantry regiments in a division, one regiment of cavalry, and three and sometimes four batteries of artillery, or about twenty pieces. To each division generally one regiment of cavalry was assigned, and one or two of them had four instead of three batteries.

Further up the Potomac, was Gen. Kelly's force, of which Gen. Lander soon took command, looking up the valley of the Shenandoah, toward Winchester. Gen. Rosecrans was in western Virginia, with a force somewhat less than 20,000 men.

At Louisville, in Kentucky, Gen. Buell had collected and combined the scattered Federal forces, and was now organizing and preparing for future operations, an army of more than 100,000 men. At St. Louis and Cairo, Gen. Halleck was performing a similar service, and at the same time holding in check the Confederate forces in Missouri, and preparing to drive them entirely over its southern border. The force he was thus organizing, was nearly equal to that under Gen. Buell in Kentucky.

On the western frontier preparations were also making for an expedition, which was designed to be more than 20,000 strong, for the purpose of penetrating from Kansas to the Gulf of Mexico. A naval force was also collected at Cairo and St. Louis, to cooperate, by gunboats, with the military force, at important points on the western rivers. The entire Federal force, including the troops under Gen.

Sherman in South Carolina, and those under Gen. Burnside on their way to North Carolina, and the regiments designed for the expedition under Gen. Butler, made not more than 450,000 to 475,000 in the field.

The position and force of the Confederate army at the commencement of the year, were nearly as follows: At Norfolk and Yorktown there was a considerable force, probably over 30,000 men. The larger portion of this force was at Yorktown. A small force also manned batteries on the James and York rivers. The army before Washington was fortified on a very extended line. Its right wing rested upon the Potomac, beyond Fredericksburg, and at Stafford Court House, Dumfries, &c., and thus formed a support to the batteries which blockaded the Potomac river, and endangered the navigation between Washington and the lower Potomac into Chesapeake Bay. The main body was at Centreville and Manassas. The former place was strongly fortified, and held not less than 75,000 troops. The left wing occupied Aldie and Leesburg, and considerable forces were stationed at Winchester and Martinsburg. This entire force has been estimated to have reached 175,000 men, under Gen. Joseph Johnston. A small force was in western Virginia.

In Kentucky, the Confederate forces were stationed at Prestonburg, Hazel Green, Bowling Green, Columbus, Hickman, Donelson and Fort Henry, and amounted to 30,000 men.

The points occupied by the Confederate forces in Tennessee, were Cumberland Gap, Nashville, Waverly, Humboldt, Chattanooga, Jonesboro, Memphis, and forts Osceola, Wright, Randolph, Rector and Harris. These troops amounted to 20,000 men.

There were also Confederate troops stationed at Vicksburg, Natchez, New Orleans, Mobile, Savannah, Charleston, and at various points in Missouri. The total force under arms, was not far from 350,000 men.

The Confederate forces at this time occupied half of Missouri, nearly half of Kentucky, including the strong positions of Columbus and Bowling Green, western Virginia, nearly as far north as the Kanawha river, the whole of eastern Virginia, except a few miles around Washington and Fortress Monroe and Newport News, the whole of North Carolina, except Hatteras Inlet, the whole of Florida except Key West, and Santa Rosa Island, and all the rest of the Southern States.

The results of the previous year when compared with the purposes entertained by the citizens of the North, appear most insignificant. But this is not a true view of the case. It was too soon to expect results, and nothing was done which had any influence upon the termination of the war. These gigantic combatants were yet unprepared for the conflict. Armies had been collected and hastily equipped, and the work of organization and discipline to change raw militia into men of war was progressing on both sides. So unused, however,



40

5

80

70

were the people to such events, that a speedy close of the contest had been anticipated by them. War, in their minds, was to be begun, carried on, and closed up with the despatch of ordinary enterprises.

It was not only necessary to organize and discipline armies, but to provide food, munitions, and transportation, and to organize artillery reserves, the engineer corps, the pontoon trains, the telegraphs, and the hospitals; but also to manufacture or import from other countries cannon, carriage harness, cavalry equipments, small arms, artillery, camp equipage, bridge trains, &c. The time required to secure these objects, under the most favorable circumstances, was even longer than had been assigned for the duration of hostilities by the people of both the Northern and Southern States.

The Federal Government proposed to blockade the coast to cut off the Confederate States from all communication with other nations. The recovery of the Mississippi valley, by which the western States of the Confederacy would be separated, and the outlet of the Northwest to the ocean recovered, was also a part of the purpose of the Government. The recovery of the Border Slave States by actual military force, and their protection against invasion by the Confederate Government, which claimed them as a part of its Union, was the occasion of the most active and extensive military operations. It was anticipated that the signal success which would attend the execution of these purposes, would so emphatically convince the Southern people of the irresistible power of the North as to satisfy them that the attainment of their independence was hopeless. At the same time it was believed their efforts of resistance would so exhaust their limited resources as to make a return to the Union on their part a necessity. Such appear to have been the purposes of the Federal Government, and such were the views of the people. On the opposite side, the purposes of the Confederate Government were no less determined, and the views of the people no less sanguine and exalted. A defence was to be made to the last extremity, and if this was successful, an invasion of the enemy was to follow, when the smoking ruins of Philadelphia, New York, and Cincinnati would wring humiliating conditions from the North. The year which passed has thus witnessed most stupendous military operations conducted on a theatre which was almost the size of a continent, with a profusion of expenditure and a waste of resources sufficient to engulf most nations. The actors in these terrific scenes now stand forth to receive the judgment of mankind not only upon their skill, ability, and sincerity, but upon those higher and nobler qualities which are the jewels of humanity.

The military operations in the interior of the country have been conducted chiefly with a reference to the lines of the railroads and the water courses. The facilities for the transportation of supplies and for the concentration of

men furnished by these railroads and the rivers, in a country so covered with woods, and so poorly supplied with common roads, has resulted in making some of them the base of all important movements.

At the beginning of the year preparations were vigorously pushed forward both at the West and with the Army of the Potomac. The forces of each side on the line between the Federal and Confederate States maintained their respective positions during the month of January, excepting in eastern Kentucky. There Col. Humphrey Marshall had a few months previous intrenched the Confederate forces under his command, consisting of a few regiments of infantry, one battery of artillery, and five or six companies of cavalry at a town called Paintville. It was expected in the Confederate States that he would be able to sweep the whole of eastern Kentucky, take possession of Frankfort, the seat of the State Government, and set up the authority of the Provisional Governor Johnson. Meanwhile Col. John A. Garfield, commanding a brigade of Union forces, having the 42d Ohio and 14th Kentucky infantry and a squadron of Ohio cavalry, advanced to encounter the Confederate force. Embarrassed by the difficulty of moving supplies at that low stage of the Big Sandy river, it was the 7th of January when his advance, consisting of five companies of the 42d Ohio, under Lieut.-Col. Sheldon, reached Paintville. The Confederate force had then evacuated its intrenchments two and a half miles south of the town, but a part of it was placed in ambush at Jennie Creek, two miles west. This body was driven out immediately by Col. Bolles, of the 1st Virginia cavalry, who had come up. At the same time Col. Garfield, with eight companies of the 42d Ohio and two companies of the 14th Kentucky, moved upon the main position of the enemy, who were found to have hastily retreated. On the next day the 40th Ohio, Col. Cranox, and six companies of the 1st Kentucky cavalry joined Col. Garfield; a part of the 22d Kentucky, under Lieut.-Col. Munroe, had also reached him. With a portion of this force, the pursuit of the enemy was immediately commenced up the road along the Big Sandy river.

The following despatches from Col. Garfield describe his movements:

PAINTSVILLE, January 8.

To Capt. J. B. Fry, Assistant Adjutant-General:

I entered this place yesterday with the 42d Ohio, the 4th Kentucky, and 800 of the 2d Virginia cavalry. On hearing of my approach, the main rebel force left their strongly intrenched camp and fled. I sent my cavalry to the mouth of Jennie Creek, where they attacked and drove the rebel cavalry, which had been left as a vanguard, a distance of five miles, killing three and wounding a considerable number.

Marshall's whole army is now flying in utter confusion. He had abandoned and burned a large amount of his stores. We have taken fifteen prisoners. Our loss is two killed and one wounded. I start in pursuit to-morrow morning.

(Signed)

J. A. GARFIELD,  
Col. commanding Brigade.



## SECOND DISPATCH.

*To Capt. J. B. Fry, Assistant Adjutant-General:*

I left Paintsville on Thursday noon with 1,100 men, and drove in the enemy's pickets two miles below Prestonburg. The men slept on their arms. At 4 o'clock yesterday morning we moved toward the main body of the enemy at the forks of Middle Creek, under command of Marshall. Skirmishing with his outposts began at 8 o'clock, and at 1 p. m. we engaged his force of 2,500 men and 3 cannon, posted on the hill—fought them until dark, having been reinforced by 700 men from Paintsville, and drove the enemy from all their positions. He carried off the majority of his dead and all of his wounded.

This morning we found twenty-seven of his dead on the field. His killed cannot be less than sixty. We have twenty-five prisoners, ten horses, and a quantity of stores. The enemy burned most of his stores, and fled precipitately. To-day I have crossed the river, and am now occupying Prestonburg. Our loss is—two killed and twenty-five wounded.

(Signed) J. A. GARFIELD,  
Col. commanding Brigade.

This was a rapid and spirited movement on the part of Col. Garfield, and it resulted in forcing Col. Humphrey Marshall with his troops to retire from eastern Kentucky.

On the 16th of January Col. Garfield issued the following address to the inhabitants:

HEADQUARTERS EIGHTEENTH BRIGADE,  
PAINTSVILLE (KY.), January 16, 1862.

*Citizens of the Sandy Valley:*

I have come among you to restore the honor of the Union and to bring back the Old Banner, which you all once loved, but which, by the machinations of evil men and by mutual misunderstanding, has been dishonored among you. To those who are in arms against the Federal Government I offer only the alternative of battle or unconditional surrender. But to those who have taken no part in this war, who are in no way aiding or abetting the enemies of the Union—even to those who hold sentiments averse to the Union, but yet give no aid and comfort to its enemies—I offer the full protection of the Government, both in their persons and property.

Let those who have been seduced away from the love of their country to follow after and aid the destroyers of our peace lay down their arms, return to their homes, bear true allegiance to the Federal Government, and they shall also enjoy like protection. The army of the Union wages no war of plunder, but comes to bring back the prosperity of peace. Let all peace-loving citizens who have fled from their homes return and resume again the pursuits of peace and industry. If citizens have suffered from any outrages by the soldiers under my command, I invite them to make known their complaints to me, and their wrongs shall be redressed and the offenders punished. I expect the friends of the Union in this valley to banish from among them all private feuds, and let a liberal-minded love of country direct their conduct toward those who have been so sadly estranged and misguided, hoping that these days of turbulence may soon be ended and the days of the Republic soon return.

J. A. GARFIELD,  
Col. commanding Brigade.

But the most important action of the month was fought at a place called Webb's Cross Roads on the 19th. It is known as the battle of Mill Springs, although this place is about five miles distant from the spot where the battle was fought. For three months previous the Federal General Schoepff had been stationed at Somerset, a small town in south-eastern Kentucky, with a force of about 8,000 men. The

object was to prevent the advance of the Confederate force any further north. At the same time the Confederate General Zollicoffer, with nearly the same force, was entrenched directly south on both banks of the Cumberland river, for the purpose of defending the approach to the Cumberland Gap and the road into east Tennessee against any Federal force. About two weeks previous to the action, Gen. Zollicoffer was reinforced by the division under Gen. Crittenden, which had been previously stationed at Knoxville, Tennessee. Gen. Crittenden took command, and issued the following proclamation:

DIVISION HEADQUARTERS, MILL SPRINGS, KY.,  
January 6, 1862.

*To the People of Kentucky:*

When the present war between the Confederate States and the United States commenced, the State of Kentucky determined to remain neutral. She regarded this as her highest interest, and, balancing between hope for the restoration of the Union and love for her Southern sisters, she declared and attempted to maintain a firm neutrality.

The conduct of the United States Government toward her has been marked with duplicity, falsehood, and wrong. From the very beginning, the President of the United States, in his Messages, spoke of the chosen attitude of Kentucky with open denunciation, and on the one hand treated it with contempt and derision, while on the other hand he privately promised the people of Kentucky that it should be respected. In violation of this pledge, but in keeping with his first and true intention, he introduced into the State arms which were placed exclusively in the hands of persons known or believed to be in favor of coercion, thus designing to control the people of Kentucky, and to threaten the Confederate States. Then the Government of the Confederate States, in self-defence, advanced its arms into your midst, and offer you their assistance to protect you from the calamity of Northern military occupation.

By the administration of your State Government, Kentucky was being held to the United States, and bound at the feet of Northern tyranny. That Government did not rest upon the consent of your people. And now, having thrown it off, a new Government has been established and Kentucky admitted into the Southern Confederacy. Can Kentuckians doubt which Government to sustain? To the South you are allied by interest, by trade, by geography, by similarity of institutions, by the ties of blood, and by kindred courage. The markets of the North do not invite your products—your State is, to the centre of its trade, society, and laws, but a distant province, despised for its customs and institutions—your heroic lineage forbids association in arms with their warriors of Manassas, of Leesburg, and of Belmont; and your former devotion to the Union must intensify your hatred toward that section which has, in its Abolition crusade, broken to pieces the Constitution, and which is now vainly endeavoring to destroy the liberty of the Southern States!

At first you may have been deceived as to the purposes of the North. They talked of restoring the Union. Do you not see that it is hopelessly lost in the storm of war, and that, while the rotten Government of the North is shaking over its ruins, the South has erected out of them a new, powerful, and free constitutional republic! And now, indeed, the mask is thrown off, and you find the North, through its President, and Secretary of War, and public journals, and party leaders, giving up the claim of Union, and proclaiming the extinction of slavery and the subjugation of the South. Can you join in this enterprise? The South would never in any event consent to a reconstruction. She is contending with unconquerable spirit, with great

military power, with unbroken success, for constitutional freedom, and for her own national government. Where is your spirit of other days, that you do not rush to her victorious standard? Shall the sons of Tennessee, Virginia, Mississippi, and other Southern States, with whom you have gathered the laurels on other battle fields, win them all in this war of independence, while you are inactive and lost in slothful indolence? May the proud genius of my native Kentucky forbid it.

In these mountains, where freedom and patriotism stir the human heart, can you sleep with the clarion of a glorious war ringing in your ears? True, you have refused to bear the arms and wear the livery of Northern despotism. Their base hirelings have been among you, but have not seduced you into their ranks. Will you stay at home and let noble bands of soldiers, armed in your cause as in their own, pass on to battle fields, on your own soil, consecrated by no deed of your valor?

Having assumed command of the forces of the Confederate States on Cumberland river, in south-eastern Kentucky, I make this appeal to you. You are already assured that we come among you as friends and brothers, to protect you in your personal liberties and property, and only to make war against the invaders of your home and our common enemies. I invoke you to receive us as brothers, and to come to our camp and share with us the dangers and the honor of this struggle. Come to these headquarters, as individuals or in companies, and you will be at once accepted and mustered in with pay and arms from the Government of the Confederate States. At first many Kentuckians entered the army of the South for the great cause it supports; now this has become the cause of Kentucky, and it is your duty to espouse it. Duty and honor unite in this call upon you. Will you join in the moving columns of the South, or is the spirit of Kentucky dead? GEO. B. CRITTENDEN, Major-General.

Previous to the junction of the force of Gen. Crittenden with that of Gen. Zollicoffer, Gen. Buell, in command of the Federal department, with his headquarters at Louisville, had detached from his main body a division under Gen. Geo. H. Thomas to attack the rear of Gen. Zollicoffer, whose position was a strong one. It was about fifteen miles south-west of Somerset, forty miles south-east of Columbia, and six miles below the head of steamboat navigation. It was considered to be one of the three Confederate strongholds in Kentucky—the first being Columbus, in the extreme West; the second, Bowling Green in central Kentucky; and the third, this one in the south-east, commanding the coal mines and many of the salt wells south of the Cumberland, and suitable to check any Federal advance into east Tennessee. The hills on the immediate bank of the river are between three and four hundred feet in height and their summits were fortified. The actual situation of the Confederate force has been variously represented. It was nearly destitute of supplies, and upon hearing of the approach of the Federal force, the choice was presented to Gen. Crittenden, either to retreat without striking a blow, or to remain in his position and be stormed out, or to surrender upon the approach of starvation, or to make an advance. The latter measure was chosen, and for this reason the Confederate general was found without his intrenchments and making an attack upon the approaching

force. It is probable, however, that the Federal force was supposed to be much smaller than it in truth was, and hence the Confederate general was tempted to advance and make an attack. That day (Sunday) he was defeated and retired to his intrenchments. During the night he abandoned his camp, and by the aid of a small steamboat crossed the Cumberland with his entire force. The Federal forces most actively engaged were: the 9th Ohio, Col. McCook; 2d Minnesota, Col. Van Cleve; 4th Kentucky, Col. Fry; 10th Indiana, Col. Munson; with the batteries of Capts. Stanhart and Wetmore. These were supported by the 14th Ohio, Col. Steadman; and the 10th Kentucky, Col. Haskin. The force of Gen. Schœpff came up and joined in the pursuit. The Confederate force consisted of the 15th Mississippi, Col. Walthal; 19th Tennessee, Col. Cummings; 20th Tennessee, Capt. Battle; 25th Tennessee, Capt. Stouton; 17th Tennessee, Col. Newman; 28th Tennessee, Col. Murray; 29th Tennessee, Col. Powell; 16th Alabama, Col. Wood, with two batteries. The Federal loss was 88 killed and 194 wounded; the Confederate loss was 190 killed (among whom was Gen. Zollicoffer), 60 wounded, and 89 prisoners. The forces of Gen. Thomas and Gen. Crittenden were about equal. The force of Gen. Schœpff, however, was equal to a reserve for Gen. Thomas. The artillery of Gen. Thomas was of longer range than the Confederate guns.

The following order of thanks was issued by President Lincoln in consequence of this victory:

WAR DEPARTMENT, *January 22, 1862.*

The President, commander-in-chief of the army and navy, has received information of a brilliant victory achieved by the United States forces over a large body of armed traitors and rebels at Mill Springs, in the State of Kentucky.

He returns thanks to the gallant officers and soldiers who won that victory; and when the official reports shall be received, the military skill and personal valor displayed in battle will be acknowledged and rewarded in a fitting manner.

The courage that encountered and vanquished the greatly superior numbers of the rebel force, pursued and attacked them in their intrenchments, and paused not until the enemy was completely routed, merits and receives commendation.

The purpose of this war is to attack, pursue, and destroy a rebellious enemy, and to deliver the country from danger menaced by traitors. Alacrity, daring, courageous spirit, and patriotic zeal, on all occasions and under every circumstance, are expected from the army of the United States.

In the prompt and spirited movements and daring battle of Mill Springs, the nation will realize its hopes, and the people of the United States will rejoice to honor every soldier and officer who proves his courage by charging with the bayonet and storming intrenchments, or in the blaze of the enemy's fire.

By order of the President.

EDWIN M. STANTON, Secretary of War.

This victory opened the path into east Tennessee, but no advantage was taken of it by the Federal Government. It also produced an exhilaration in the North far above its importance.

Some important reconnaissances were made in western Kentucky at this time, extending even to the Tennessee line. The country around Fort Columbus was fully explored, the length and condition of the roads ascertained, the number of bridges and their strength, the depth of the streams without bridges, and the sentiments of the inhabitants. Fort Henry was twice approached by the gunboat Lexington, and its strength estimated. These reconnaissances were made by forces from the Department of Missouri, then under the command of Maj.-Gen. Halleck. Early in January troops began to concentrate at Cairo, Paducah, and Fort Jefferson from different quarters. To such an extent had this progressed that, in the public mind, it was supposed that a great movement was on foot.

The plan of the campaign in the West now began to be manifest. At the time when Gen. Buell was ordered to the command of the department of the Ohio, the views of the Government were favorable to an expedition to the Cumberland Gap and into east Tennessee, for the purpose of seizing the Virginia and east Tennessee line of railroad and affording aid to the loyal citizens. The Confederate line of defence had now become so fully developed, with its strong positions of Bowling Green and Columbus, that the propriety of an expedition by the forces in Kentucky into east Tennessee became a question for military investigation. The mountainous character of the country through which the Gap had to be reached, the roughness of the roads, rendering the conveyance of artillery extremely difficult and slow, and subjecting an army at every interval to formidable resistance, were discouraging obstacles to an advance in that direction.

On the other hand, the movement of troops from Cairo up the Cumberland river by transports and gunboats against Nashville, so as to reach the rear of the Confederate army under Gen. Buckner, presented an easy manner of breaking the enemy's line and compelling the evacuation of Kentucky. Its successful achievement might be attended with the capture of the Confederate force at Bowling Green. These views finally prevailed and measures were taken to carry them into execution. The original plan of the western campaign had been for a military and naval expedition to proceed from St. Louis and Cairo down the Mississippi river. For this purpose the gunboats were originally constructed. They were found to be of sufficiently light draft to navigate the Cumberland and Tennessee rivers, and the coöperation of the western department under Gen. Halleck was also secured. Indeed the Mississippi river expedition was thus diverted at the outset, and Gen. Halleck, by order of the President, assumed the entire command. After a union of these two armies, they were expected to control the whole country to New Orleans.

The reconnaissances of Fort Henry had con-

vinced Com. Foote, in command of the western fleet of gunboats, that it could be easily reduced by his gunboats. At an early day he applied to Gen. Halleck for permission to attack the fort. These views undoubtedly had an important influence on the plan of the western campaign.

The States which contributed chiefly to the force organized by Gen. Buell in Kentucky were: Ohio, Kentucky, Indiana, Illinois, Michigan, Wisconsin, Minnesota, Pennsylvania, and Tennessee, as follows: Ohio, thirty regiments of infantry, two and half regiments of cavalry, and eight batteries of artillery; Indiana, twenty-seven regiments of infantry, one and half regiments of cavalry, and five batteries of artillery; Illinois, three regiments of infantry; Kentucky, twenty-four regiments of infantry, four regiments, of cavalry, and two batteries of artillery; Pennsylvania, three regiments of infantry, two regiments of cavalry, one battery of artillery; Michigan, three regiments of infantry, one battery of artillery; Wisconsin, three regiments of infantry; Minnesota, two regiments of infantry, and one battery of artillery; Tennessee, two regiments of infantry. Besides these there were of regulars, three regiments of infantry, and three batteries of artillery. Thus making one hundred and two regiments of infantry, ten regiments of cavalry, and twenty-one batteries of artillery; which might be summed up as follows: infantry 100,000, cavalry 11,000, artillerists 8,000; total 114,000 men, and 126 pieces of artillery. This army was divided into four grand divisions under the command of Gens. Alexander McDowell McCook, Geo. H. Thomas, Ormsby M. Mitchell, Thos. L. Crittenden. Among the brigade commanders, of whom there were twenty, were the following officers: Ebenezer Dumont, Albin Schœpff, Thos. J. Wood, Wm. Nelson, Richard W. Johnson, Jerre T. Boyle, Jas. S. Negley, Wm. T. Ward.

The force organized by Gen. Halleck, with his headquarters at St. Louis, was concentrated at that place and Cairo and Paducah, excepting that portion which was in the field in the State of Missouri. It was somewhat less in numbers than the army of Gen. Buell. For operations in Kentucky and Tennessee it was placed under the command of Gen. Grant. It was drawn chiefly from the States adjacent to Missouri.

The naval force prepared to coöperate with the military consisted of twelve gunboats carrying an armament in all of one hundred and twenty-six guns. None of these guns were less than 82-pounders, some were 42-pounders, and also 9 and 10-inch naval columbiads. In addition, each boat carried a rifled Dahlgren 12-pounder boat howitzer on the upper deck. Several of the larger guns on each boat were rifled.

The boats were built very wide, in proportion to their length, giving them almost the same steadiness in action that a stationary land battery would possess. They were constructed

with the sides sloping upward and downward from the water line, at an angle of forty-five degrees. The bow battery on each boat consisted of solid oak timber twenty-six inches in thickness, plated on the exterior surface with iron two and a half inches thick.

The side and stern batteries were somewhat thinner, but had the same thickness of iron over that portion covering the machinery.

The boats were built so that in action they could be kept "bow on;" hence the superior strength of the bow battery. Broad-sides were so arranged as to be delivered with terrible effect while shifting position. To facilitate movements in action, the engines and machinery were of the most powerful kind. The boilers were five in number, constructed to work in connection with or independent of each other.

Seven of these boats only were iron clad. The number of mortar boats ordered was thirty-eight. Each one which was built, carried a mortar of 18-inch calibre. The charge of powder for the mortar was about twenty-three pounds. Each boat was manned by a captain, lieutenant, and twelve men. Formidable as this naval force appears, its preparation was very tardily undertaken by the Government, and at the moment when first needed, but few of the boats were ready.

On the 27th of January, the President of the United States appeared as commander-in-chief of the army and navy, and issued the following order:

EXECUTIVE MANSION, WASHINGTON, Jan. 27, 1862.  
PRESIDENT'S GENERAL WAR ORDER, No. 1.

*Ordered,* That the 22d day of February, 1862, be the day for a general movement of the land and naval forces of the United States against the insurgent forces.

That especially

The Army at and about Fortress Monroe,  
The Army of the Potomac,  
The Army of Western Virginia,  
The Army near Munfordsville, Kentucky,  
The Army and Flotilla at Cairo,  
And a Naval Force in the Gulf of Mexico,

be ready for a movement on that day.

That all other forces, both land and naval, with their respective commanders, obey existing orders for the time, and be ready to obey additional orders when duly given.

That the Heads of Departments, and especially the Secretaries of War and of the Navy, with all their subordinates, and the General-in-Chief, with all other commanders and subordinates of land and naval forces, will severally be held to their strict and full responsibilities for the prompt execution of this order.

ABRAHAM LINCOLN.

This order was unproductive of direct military effect, but was viewed as an indication of the President's desire that active measures should be taken speedily toward the initiation of hostilities. Gen. McClellan still continued to be general-in-chief, and all the movements of Gen. Buell up to the occupation of Nashville, and those of Gens. Halleck and Grant, were made under his instructions up to the 11th of March, when the order of the President was issued, relieving him "from the command of the other military departments."

By the "Army near Munfordsville, Kentucky," were designated the forces of Gen. Buell. After the battle of Mill Springs, movements were made by order of Gen. Buell, as if with the purpose of advancing into eastern Tennessee in force. The Cumberland river was crossed at Waitaboro', and a column was pushed toward Cumberland Gap, while two brigades were moved from Gen. Buell's centre toward his left. The Confederates understood that east Tennessee was the destination of these troops, and hastily sent a large force by railroad from Bowling Green through Nashville to Knoxville. But the army of Gen. Thomas, instead of going to east Tennessee, turned back to Danville and subsequently marched to join Gen. Nelson, at Glasgow, and flank Bowling Green on the left. Thus, instead of dividing his forces, Gen. Buell concentrated them by a movement from the left to the centre. Meanwhile the centre of Gen. Buell's force, under Gen. Mitchell, had been advanced toward Munfordsville, on the road to Bowling Green.

By the term "The Army and Flotilla at Cairo," was designated the military force of Gen. Halleck's department, collected at Cairo, Paducah, and Fort Jefferson, under Gen. Grant, together with the gunboats, and intended for the Tennessee river expedition.

A movement against Fort Henry on the Tennessee river was at once undertaken. This fort is situated near the line of Kentucky and Tennessee, on the east bank of the stream. It stands on the low lands adjacent to the river, about the high water mark, and being just below a bend in the river, and at the head of a straight stretch of about two miles, it commands the river for that distance, and very little else. On Saturday night, Feb. 1, the gunboats St. Louis, Cincinnati, Carondelet, Essex, Tyler, and Lexington, in an incomplete state of preparation, being the only ones manned, left Cairo, and proceeded to the mouth of the Tennessee at Paducah. Here they were joined by the gunboat Conestoga and a fleet of transports, with a land force under Gen. Grant, and on Monday afternoon proceeded up the river. By Tuesday all were anchored about eight miles below the fort, which being an unfavorable place for the debarkation of troops, a reconnaissance was made by the Essex, St. Louis, and Cincinnati. A suitable place for the landing, encampment, and general rendezvous of the troops was found just below the range of the guns of the fort. The troops were landed during the afternoon, and the transports returned to Paducah for more regiments. By Thursday morning, Feb. 6, a large force was gathered, and a body of troops under Gen. Smith were also landed on the west side of the river, where it was supposed that a considerable Confederate force was encamped. The troops after being landed were formed into two divisions; the first, consisting of the 8th, 18th, 27th, 29th, 30th, and 31st, making one brigade; and the 11th, 20th, 45th, and 48th Illinois regiments making

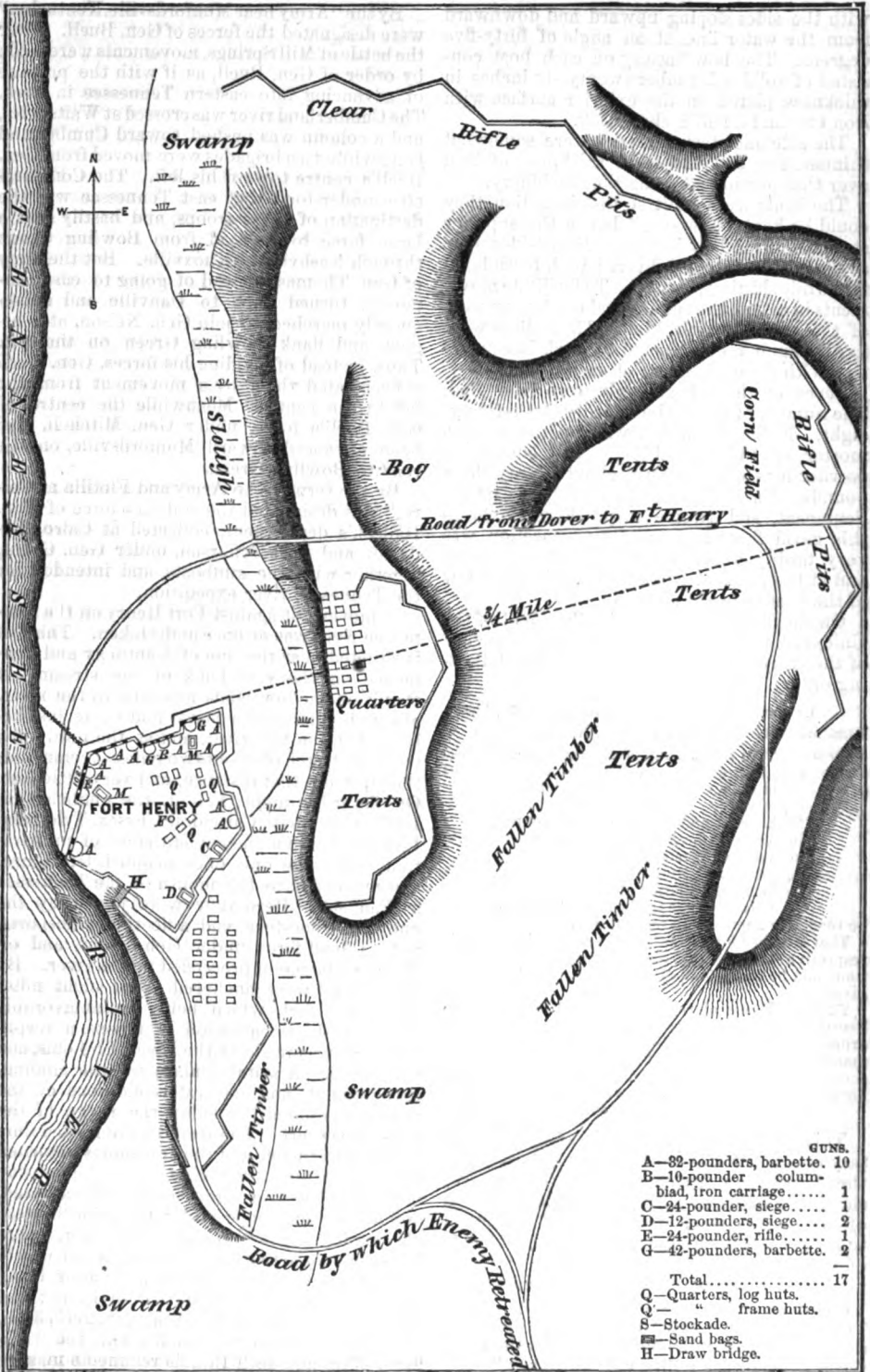

another brigade, with one regiment (the 4th Illinois), and four independent companies of cavalry, and four batteries of artillery, under Gen. McClelland. This division was ordered to move across the country to a point on the road leading from the fort to the town of Dover, on the Cumberland river, for the purpose of preventing reinforcements to the enemy and cutting off his retreat. The second division consisted of the 7th, 9th, 12th, 28th, and 41st Illinois regiments, the 11th Indiana, 7th and 12th Iowa, 8th and 13th Missouri, with artillery and cavalry, under Gen. Smith. About ten o'clock the land force commenced the march over the hilltops, and the gunboats began to move under steam toward the fort. Passing up the narrow passage to the westward of the island below the fort, they were protected from its guns until within a mile, and emerged in line of battle, the St. Louis, Lieut. Paulding, on the left, next the Carondelet, Commander Walke, next the flag ship Cincinnati, Commander Stembel, and next upon the right the Essex, Commander Porter. The other boats acted as a reserve. Firing upon both sides soon commenced, but the gunboats continued to approach until within six hundred yards of the Confederate batteries. The action lasted for one hour and a quarter, when the flag on the fort was hauled down. Meantime the high water and muddy roads prevented the arrival of the land forces under Gen. Grant, and the Confederate troops in the fort retired, and escaped. Commodore Foote, commanding the naval portion of the expedition, says: "The garrison, I think, must have commenced their retreat last night, or at an early hour this morning. Had I not felt it an imperative necessity to attack Fort Henry to-day, I should have made the investment complete and delayed until to-morrow, so as to secure the garrison. I do not now believe, however, the result would have been any more satisfactory."

This Confederate force was supposed to number between four and five thousand. The fort was armed with twenty guns, 32 and 84-pounders, including one 10-inch Columbiad. Before the close of the action a shot entered the boiler of the Essex, which resulted in wounding and scalding twenty-nine officers and men. Eighty-three prisoners were taken, among whom was Brig. Gen. Tilghman, and a large amount of stores, and everything belonging to the retiring force. On the gunboats two were killed and nine wounded in the action, and on the part of the Confederates five killed and ten wounded.

The result of this action occasioned great joy in the Northern States. The Secretary of the Navy, Gideon Welles, sent the following despatch to Com. Foote:

NAVY DEPARTMENT, February 9, 1862.

Your despatch announcing the capture of Fort Henry, by the squadron which you command, has given the highest gratification to the President, to Congress, and the country. It was received and read in both

Houses of Congress in open session. The country appreciates your gallant deeds, and this department desires to convey to you and your brave associates its profound thanks for the service you have rendered.

GIDEON WELLES.

Secretary of the Navy.

Flag Officer A. H. Foote, U. S. N., commanding the United States naval forces, Cairo, Ill.

By the possession of Fort Henry the Federal forces were in the rear of Columbus on the Mississippi, and within ten miles of the bridge by which the railroad connection was made between Columbus and Bowling Green. There was now no obstacle to the passage of the gunboats to the sources of the Tennessee river in northern Alabama.

Immediately after the surrender, Commander Phelps was ordered to proceed with the gunboats Conestoga, Tyler, and Lexington, up the river to the railroad bridge, and to destroy so much as would prevent its use by the enemy, and thence proceed as far up the river as the stage of water would permit, and capture the gunboats and other vessels which might be useful to the enemy.

After dark, on the same day, the expedition arrived at the bridge for the railroad crossing about twenty-five miles above Fort Henry, where considerable camp equipage was destroyed. Thence the expedition proceeded as far up the river as Florence in Alabama, at the foot of the Muscle shoals. Here the enemy burnt six of their steamers and two were captured, beside a half complete gunboat and considerable lumber. Two hundred stands of arms, a quantity of stores and clothing were also seized, and the encampment of a regiment destroyed. This sudden appearance of the Federal gunboats was like an unexpected apparition to the inhabitants, and loyal and friendly feelings were manifested on every side.

The next step of Com. Foote was to return to Cairo to prepare the mortar boats for operations against Fort Donelson. He desired a delay of a few days to complete them, believing that thereby the garrison, however extensive, could be shelled out without much loss of life to the Federal force. But Gen. Halleck regarded an immediate attack as a military necessity, and it was made although the fleet was reduced to a crippled state, and the loss of life was considerable. There is no question of the correctness of Gen. Halleck's views relative to the attack; the deficiency resulted from a degree of precipitation in the entire movement after the issue of the President's proclamation.

At this time Gen. Crittenden, in command of the right wing of Gen. Buell's army, having advanced to the left bank of Green river near South Carrollton and manœuvred in front of the Confederate (Gen. Buckner's) force, suddenly retreated to Calhoun on Green river. Steamers were there awaiting him, on which his force was embarked and taken down the Green river to the Ohio, down the Ohio, and

up the Cumberland, where a junction was effected with Gen. Grant's army.

Troops were also sent from St. Louis, Cairo, and Cincinnati, until the following regiments and batteries were under the command of Gen. Grant, not including the force brought by Gen. Crittenden:

*Illinois Infantry.*—7th, Col. John Cook, acting brigadier-general; Lieut.-Col. Andrew J. Babcock; 8th, Col. Richard J. Oglesby, acting brigadier-general; Lieut.-Col., Frank L. Rhodes; 9th, Col. Augustus Marsey; 10th, Col. James D. Morgan; 11th, Col. Thomas E. Ransom; 12th, Col. John McArthur; 16th, Col. Robert F. Smith; 18th, Col. Michael K. Lawler; 20th, Col. C. Carroll Marsh; 22d, Col. Henry Dougherty (invalid); Lieut.-Col. H. E. Hart; 27th, Col. Napoleon B. Buford; 28th, Col. Amory K. Johnson; 29th, Col. James S. Riordan; 30th, Col. Philip B. Fouke, absent; Lieut.-Col. E. B. Dennis; 31st, Col. John A. Logan; 32d, Col. John Logan; 41st, Col. Isaac C. Pugh; 45th, Col. John E. Smith; 46th, Col. John A. Davis; 48th, Col. Isham N. Haynie; 49th, Col. Wm. R. Morrison, wounded; Lieut.-Col., Thomas G. Allen; 50th, Col. Moses M. Bane; 52d, Lieut.-Col. John S. Wilcox; 55th, Col. David Stuart; 57th, Col. S. D. Baldwin.

*Illinois Artillery.*—2d regiment, Col. Silas Noble; 3d regiment, Col. Eugene A. Carr; 4th regiment, Col. T. Lyle Dickey; 7th regiment, Col. William Pitt Kellogg.

*Illinois Artillery Batteries.*—Schwartz's, Dresser's, Taylor's, McAllister's, Richardson's, Willard's, and Buell's; in all, thirty-four guns.

*Troops from other States.*—3d Iowa, Col. N. G. Williams; 7th Iowa, Col. John G. Lauman; 11th Iowa, Col. Abraham F. Hare; 12th Iowa, Col. Jackson J. Wood; 18th Iowa, Col. Marcellus M. Crocker; 14th Iowa, Col. William T. Shaw; 8th Missouri, Col. Morgan M. Smith; 18th Missouri, Col. Crafts J. Wright; 1st Missouri Artillery, Major Cavender; 11th Indiana, Col. George F. McGinniss; 23d Indiana, Col. Wm. L. Sanderson; 48th Indiana, Col. Norman Eddy; 52d Indiana, Col. James M. Smith.

Gen. Lewis Wallace commanded a third division, in which were the following regiments who were engaged in the battle at Donelson: 28th Kentucky, Col. James L. Shackelford; 81st Indiana, Maj. Fred. Arn; 44th Indiana, Col. Hugh B. Reed; 17th Kentucky, Col. John McHenry.

The force of Gen. Grant had grown within a few days into almost gigantic proportions. Its numbers have been variously stated. After the surrender of Donelson, Gen. Halleck sent the following despatch to Gen. Hunter:

HEADQUARTERS, DEPARTMENT OF ST. LOUIS, Feb'y 19.  
To Maj.-Gen. D. Hunter, Commanding  
Department of Kansas at Fort Leavenworth:

To you more than any other man out of this department, are we indebted for our success at Fort Donelson.

In my strait for troops to reinforce Gen. Grant, I ap-

plied to you. You responded nobly, by placing your forces at my disposal.

This enabled us to win the victory. Receive my most heartfelt thanks.

(Signed) H. W. HALLECK, Major-General.

A respectable authority wrote as follows, on the morning of Feb. 14:

At eleven o'clock last night we arrived within two miles of the fort. Here we found the Carondelet at anchor. She had been engaging the enemy during the afternoon, at a distance of a mile, had fired about two hundred shots, and retired without receiving any damage. By six o'clock this morning, sixteen transports had arrived from St. Louis, Cairo and Cincinnati, carrying in all about 10,000 troops, cavalry, artillery and infantry. The debarkation occupied about four hours. The sight of such strong reinforcements encouraged all our men greatly. Knowing already that the fort was surrounded by Gen. Grant's command—estimated at 30,000—we felt that such a large addition to his numbers would make assurance doubly sure.

Senator Trumbull thus stated, in the Senate of the United States, his view of the force engaged: "I think there is a disposition to over-estimate the number of men upon both sides in the field. We have seen a statement within a few days going the rounds of the papers, that Fort Donelson was invested by an army of fifty thousand men; I have seen it in a number of papers; but when we come to see what regiments were there, instead of being fifty thousand, there were not thirty thousand men. A gentleman direct from Cairo, well acquainted with all the troops engaged in that gallant affair, informs me that the number of our troops was less than twenty-eight thousand."

The Confederate regiments in the fort were reported as follows:

*Regiments.*—Tennessee, 11; Mississippi, 8; Texas, 1; Kentucky, 2; Arkansas, 1; Virginia, 4; Alabama, 1.

*Cavalry Battalions.*—Alabama, 1; Tennessee, 1; Mississippi, 1.

The location of the fort was on a fine slope, one hundred and fifty feet high, on a slight bend on the west side of the Cumberland river. At this point the Cumberland and Tennessee rivers, both running north, approach within about twelve miles of each other. Opposite on the Tennessee is situated Fort Henry. There were two batteries at Fort Donelson—the first about twenty-five feet above the water, consisting of nine guns, eight 32's and one 10-inch; the second having one rifled 82-pounder and two 82-pound carronades, located sixty feet higher up. The main fort was in the rear of these batteries, occupying a high range cloven by a deep gorge opening toward the south. The outworks consisted in the main of rifle pits. Along the front of the extension line, the trees had been felled and the brush out and bent over breast high, making a wide abatis very difficult to pass through. The Confederate camp was behind the hill and beyond the reach of shot and shell from the gunboats.

At three o'clock on the afternoon of Feb. 14, Com. Foote began the conflict with four

iron-clad gunboats and two wooden ones. It continued for an hour and a quarter, and the latter part of the time within four hundred yards of the fort, when the wheel of one vessel and the tiller of another were shot away, and both rendered unmanageable, and drifted down the river. At this time the Confederates appeared to be deserting their batteries along the water. The other boats were injured between wind and water, and fifty-four had been killed and wounded, when all retired. Com. Foote deeming his services to be less required on the spot than at Cairo, "until damages could be repaired, and a competent force brought up from that place to attack the fort," retired to Cairo. At the same time he sent a gunboat up the Tennessee to render the railroad bridge above Fort Henry impassable. This had not been done by Lieut. Phelps who had gone up that river with three gunboats.

The land forces under Gen. Grant left Fort Henry on the 12th of February, in two divisions, stated by Gen. Grant as "about fifteen thousand strong,"—six regiments having been sent round on transports. The head of the marching column arrived within two miles of Fort Donelson at twelve o'clock. The Confederate fortifications were from this point gradually approached and surrounded, with occasional skirmishing on the line. The next day the investment was extended on the Confederate flanks, and drawn closer to their works, with skirmishing all day. That night the gunboats and reinforcements arrived. On the next day the attack of the gunboats was made, and after its failure Gen. Grant resolved to make the investment as perfect as possible, and to partially fortify and await the repairs to the gunboats. This plan was frustrated by a vigorous attack upon his right under Gen. McClelland, by the enemy. The battle was closely contested for several hours, and with considerable advantage to the enemy, when they were finally repulsed, having inflicted upon the Union troops a loss of one thousand two hundred in killed, wounded, and missing. At this time Gen. Grant ordered a charge to be made on the left by Gen. Charles F. Smith with his division. This was brilliantly done, and the contest here, which continued until dark, resulted in giving to him possession of part of the intrenchments. Soon after this charge was commenced, an attack was ordered by Gen. Grant to be made by Gen. Wallace of the third division, and two regiments of the second division, on the other Confederate flank, by which it was still further repulsed. At the points thus gained, all the troops remained for the night, feeling that, notwithstanding the brave resistance, a complete victory awaited them in the morning.

The result of this conflict convinced the Confederate officers that without fresh troops they would be unable to hold their position on the next day. Gens. Pillow and Floyd determined therefore to withdraw as no reinforcements

would reach them, leaving Gen. Simon B. Buckner in command. By means of two or three small steamboats these officers retired during the night taking about five thousand troops with them.

Early the next morning a flag of truce was sent to Gen. Grant with the following letter :

HEADQUARTERS, FORT DONELSON, Feb. 16, 1862.

SIR: In consideration of all the circumstances governing the present situation of affairs at this station, I propose to the commanding officer of the Federal forces the appointment of commissioners to agree upon terms of capitulation of the forces at this post under my command. In that view I suggest an armistice until twelve o'clock to day.

I am, very respectfully, your obedient servant,

S. B. BUCKNER.

Brigadier-General C. S. Army.

To Brig.-Gen. U. S. Grant, Commanding  
United States forces near Fort Donelson.

The reply of Gen. Grant to this letter was as follows :

HEADQUARTERS, ON THE FIELD, }  
FORT DONELSON, Feb. 16, 1862. }

To Gen. S. B. BUCKNER :

SIR: Yours of this date, proposing an armistice and the appointment of commissioners to settle on the terms of capitulation, is just received.

No terms, except unconditional and immediate surrender, can be accepted.

I propose to move immediately on your works.

I am, very respectfully, your obedient servant,

U. S. GRANT,

Brigadier-General Commanding.

The answer of Gen. Buckner was as follows :

HEADQUARTERS, DOVER (TENN.), Feb. 16, 1862.

Brig.-Gen. U. S. Grant, U. S. Army :

SIR: The distribution of the forces under my command, incident to an unexpected change of commanders, and the overwhelming force under your command, compel me, notwithstanding the brilliant success of the Confederate arms, to accept the ungenerous and unchivalrous terms which you propose.

I am, sir, your servant,

S. B. BUCKNER.

Brigadier-General C. S. Army.

The fort was subsequently given up and occupied by the Union troops.

In the action 231 were killed and 1,007 wounded on the Confederate side. The number was larger on the Union side. About 10,000 prisoners were made, and 40 pieces of cannon and extensive magazines of all kinds of ordnance, quartermasters' and commissary stores were captured.

The following is a list of the regiments which were captured at Fort Donelson: 49th Tennessee regiment, Col. Bailey; 43d Tennessee regiment, Col. Abernethy; 27th Alabama regiment, Col. Jackson; 42d Tennessee regiment, Col. Quarrells; Captain Guy's battery; 26th Tennessee regiment, Col. Silliard; 14th Mississippi regiment, Col. Baldwin; 18th Tennessee regiment, Col. Palmer; 2d Kentucky regiment, Col. Hanson; 20th Mississippi regiment, Major Brown; Captain Milton's company; 15th Virginia regiment, Lieut. Haslep; Texas regiment, Col. Gregg; 15th Arkansas regiment, Col. Lee; Capt. Oreston's cavalry; 15th Tennessee regi-





- A** Water Batteries—Lower Battery, 8 32-pounder guns; 1 10-inch Columbiad.  
 Upper Battery, 1 82-pound heavy rifled gun; 2 32-pound carronades.
- B** Rifle Pits, carried by General Smith's division.
- C** General Grant's Headquarters during the siege.
- D** Part of Confederate Intrenchments, carried by a portion of General McClelland's division.
- E** Fallen Timber.
- F** Confederate Tents.
- G** Confederate Log Huts.
- H** Woods.

ment, Maj. Clark; one Company, Col. Lugg; Porter's artillery; 8d Tennessee regiment, Col. Brown; 8th Kentucky regiment, Capt. Lyon; 30th Tennessee regiment, Maj. Humphrey; 32d Tennessee regiment, Col. Cook; 41st Tennessee regiment, Col. Forquehanor; Mississippi regiment, Col. Davidson. A portion of the Federal troops in Gen. McClelland's division were under arms two days and nights, amid driving storms of snow and rain.

The fall of the fort occasioned great rejoicing in the Northern cities.

The commanding general (Grant) thus addressed his troops:

HEADQUARTERS, DISTRICT OF WEST TENN., }  
FORT DONELSON, Feb. 17, 1862. }

The General commanding takes great pleasure in congratulating the troops of this command for the triumph over rebellion gained by their valor on the 13th, 14th, and 15th instant.

For four successive nights, without shelter during the most inclement weather known in this latitude, they faced an enemy in large force in a position chosen by himself. Though strongly fortified by nature, all the additional safeguards suggested by science were added. Without a murmur this was borne, prepared at all times to receive an attack, and with continuous skirmishing by day, resulting ultimately in forcing the enemy to surrender without conditions.

The victory achieved is not only great in the effect it will have in breaking down rebellion, but has secured the greatest number of prisoners of war ever taken in any battle on this continent.

Fort Donelson will hereafter be marked in capitals on the map of our united country, and the men who fought the battle will live in the memory of a grateful people.

By order U. S. GRANT,  
Brigadier-General Commanding.

The following is the order of Gen. Halleck:

HEADQUARTERS, DEPARTMENT OF MISSOURI, }  
ST. LOUIS, Feb. 19, 1862. }

●The Major-General commanding the department congratulates Flag-Officer Foote, Brig.-Gen. Grant, and the brave officers and men under their command on the recent brilliant victories on the Tennessee and Cumberland.

The war is not ended. Prepare for new conflicts and new victories. Troops are concentrating from every direction. We shall soon have an army which will be irresistible. The Union Flag must be restored everywhere, and the enthralled Union men in the South must be set free. The soldiers and sailors of the Great West are ready and willing to do this. The time and place have been determined on. Victory and glory await the brave!

By command of Maj. Gen. HALLECK,  
N. H. McLEAN, Assistant Adjutant-General.

The Confederate Congress being at that time in session, the following Message was addressed to that body by President Davis:

EXECUTIVE DEPARTMENT, March 11, 1862.

To the Speaker of the House of Representatives:

I transmit herewith copies of such official reports as have been received at the War Department of the defence and fall of Fort Donelson.

They will be found incomplete and unsatisfactory. Instructions have been given to furnish further information upon the several points not made intelligible by the reports. It is not stated that reinforcements were at any time asked for; nor is it demonstrated to have been impossible to have saved the army by evacuating the position; nor is it known by what means it was found practicable to withdraw a part of the

garrison, leaving the remainder to surrender; nor upon what authority or principles of action the senior Generals abandoned responsibility by transferring the command to a junior officer.

In a former communication to Congress, I presented the propriety of a suspension of judgment in relation to the disaster at Fort Donelson, until official reports could be received. I regret that the information now furnished is so defective. In the mean time, hopeful that satisfactory explanation may be made, I have directed, upon the exhibition of the case as presented by the two senior Generals, that they should be relieved from command, to await further orders whenever a reliable judgment can be rendered on the merits of the case.

JEFFERSON DAVIS.

The successful operations against Fort Donelson were followed by the immediate evacuation of Bowling Green by the Confederate troops under Gen. Johnston. The centre of Gen. Buell's army under Gen. Mitchell was advancing from Munfordsville upon Bowling Green on the 14th of February, and by a forced march reached the river at that place on the next day. He immediately began to reconstruct the bridge, which had been burned some hours previous to his arrival, and took possession of the fortifications on the next day.

Since the battle of Mill Springs the intention of holding Bowling Green had been given up by the Confederate commander, and the troops were gradually withdrawn. About the 26th of January Gen. Floyd, with a command composed of his brigade and those of Gens. Wood and Breckinridge, left Bowling Green and went to Nashville and east Tennessee. The brigade of Gen. Buckner about the same time moved in the direction of Hopkinsville, near which place he manoeuvred in front of Gen. Crittenden until the latter left to join Gen. Grant, when Gen. Buckner fell back and combined his forces with those at Fort Donelson. The force then remaining at Bowling Green consisted of the brigades commanded by Gens. Hardee and Hindman, which were chiefly Arkansas regiments, and twelve in number. This force, being about 8,000 men, was totally inadequate to defend the position against the forces of Gen. Mitchell and the reserve of Gen. Buell commanded by Gen. McCook.

On the 19th of February Com. Foote left Fort Donelson with two gunboats Conestoga and Cairo on an armed reconnoissance. At Clarksville he learned that nearly two thirds of the citizens had fled in alarm, and therefore issued a proclamation, assuring "all peaceably disposed persons that they could with safety resume their business avocations, and requiring only the military stores and equipments to be given up and holding the authorities responsible that it should be done without reservation." Clarksville is on the line of railroad communication between Memphis and Nashville and Memphis and Bowling Green and Louisville. Below the town were two small forts which were taken by the Federal force without any resistance: They mounted three guns each. One span of the railroad bridge had also been destroyed.

The fate of Nashville was now settled. With a high state of the water of the Cumberland river, there were no obstacles to the immediate approach of the gunboats with a force on transports. The centre of Gen. Buell's army had already arrived at Bowling Green, within

your path. The fire of your artillery and the bursting of your shells announced your arrival. Surprised and ignorant of the force that had thus precipitated itself upon them, they fled in consternation.

In the night time, over a frozen, rocky, precipitous pathway, down rude steps for fifty feet, you have passed the advance guard, cavalry, and infantry, and before the dawn of day, you have entered in triumph a position of extraordinary natural strength, and by your enemy proudly denominated the Gibraltar of Kentucky.

With your own hands, through deep mud, in drenching rains, and up rocky pathways next to impassable, and across a footpath of your own construction, built upon the ruins of the railway bridge, destroyed for their protection, by a retreating and panic-stricken foe, you have transported upon your own shoulders your baggage and camp equipage.

The General commanding the department, on receiving my report announcing these facts, requests me to make to the officers and soldiers under my command the following communication :

"Soldiers who by resolution and energy overcome great natural difficulties, have nothing to fear in battle, where their energy and prowess are taxed to a far less extent. Your command have exhibited the high qualities of resolution and energy, in a degree which leaves no limit to my confidence in them in their future movements.

"By order of "Brig. Gen. BUELL,  
"Commanding Department of the Ohio."

Soldiers! I feel a perfect confidence that the high estimate placed upon your power, endurance, energy, and heroism, is just. Your aim and mine has been to deserve the approbation of our commanding officer, and of our Government and our country.

I trust you feel precisely as does your commanding General, that nothing is done while anything remains to be done.

By order of Brig.-Gen. O. M. MITCHELL,  
Commanding.

The certainty of the capture of Nashville showed to the Confederate generals the danger in which Columbus, their strong position on the Mississippi, was placed. Even the occupation of Clarksville by the Union forces put into their possession that part of the railroad running to Columbus, and opened the way to approach that position from the rear. At the same time the river in front was under the control of the Federal gunboats. Gen. Beauregard, having previously retired from his command at Manassas, was now the commanding officer in this Confederate department with Gen. Johnston. Orders were accordingly issued on the 18th of February to destroy a portion of the track and bridges of the Memphis and Ohio railroad preparatory to a removal of the forces at Columbus to Island No. Ten, about forty-five miles below on the Mississippi river.

At the same time preparations were made to remove the Confederate stores and other public property from Nashville. The near approach of the Federal forces filled the authorities of the State with great alarm. The Legislature, which had just been convened in extra session, retired with Gov. Harris to Memphis, taking the archives and treasury of the State. Extreme measures and the destruction of property were proposed by the Governor to the citizens, but without gaining their approval. The railroad and the suspension bridges over the river were, however, destroyed.

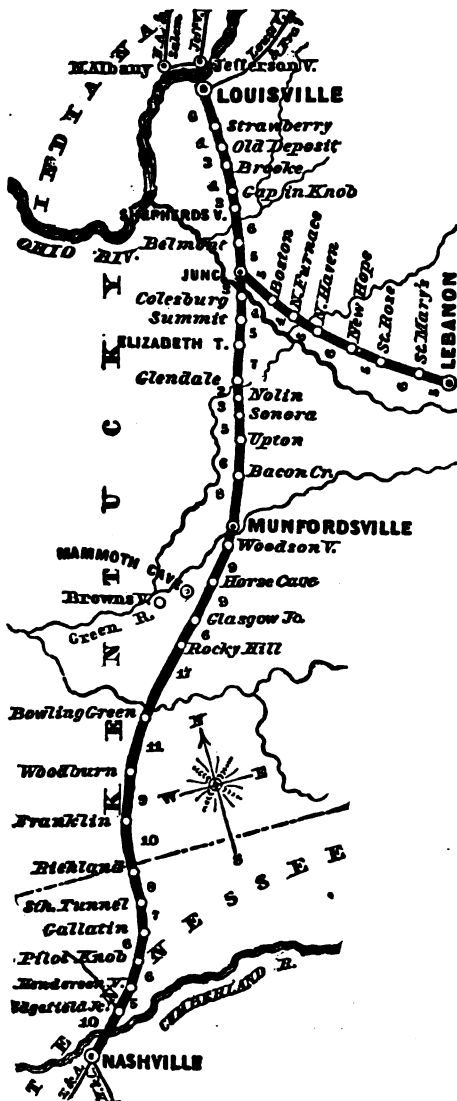

two days' march of Nashville. Its progress had been attended with many difficulties, and Brig.-Gen. Mitchell in command issued the following address to his soldiers :

BOWLING GREEN, February 19, 1862.

*Soldiers of the Third Division!* You have executed a march of forty miles in twenty-eight hours and a half. The fallen timber and other obstructions opposed by the enemy to your movements, have been swept from

After taking possession of Clarksville, Com. Foote returned to Cairo for the purpose of obtaining an additional gunboat and six or eight mortar boats. Meantime the troops of Gen. Grant, under Brig.-Gen. Smith, were pushed forward to Clarksville, and at the request of Gen. Smith, Lieut. Bryant, of the gunboat Cairo, preceded seven transports with the brigade of Gen. Nelson up the river to Nashville. They arrived on the 24th. The troops were landed without any opposition, as there was not any hostile force on the banks of the river. On the same day the advance of Gen. Buell's centre from Bowling Green arrived on the opposite side of the river, to see the Stars and Stripes already floating in triumph from the staff on the State capitol. The Confederate force under Gen. Albert S. Johnston retired to Murfreesborough, a small town thirty-two miles distant on the Nashville and Chattanooga railroad. Here they were soon after joined by the force under the Confederate General Crittenden.

An invasion having now been commenced within the limits of the States attached to the Confederacy, the Major-General commanding the department of Missouri issued the following order for the regulation of the troops:

HEADQUARTERS, DEPARTMENT OF MISSOURI, }  
St. Louis, February 22. }

The Major-General commanding the department desires to impress upon all officers the importance of preserving good order and discipline among their troops as the armies of the West advance into Tennessee and the Southern States. Let us show to our fellow citizens in these States that we come merely to crush out rebellion, and to restore to them peace and the benefits of the Constitution and the Union, of which they have been deprived by their selfish and unprincipled leaders.

They have been told that we come to oppress and plunder. By our acts we will undeceive them; we will prove to them that we come to restore, not to violate, the Constitution and laws in restoring to them the flag of the Union. We will assure them that they shall enjoy under its folds the same protection of life and property as in former days.

Soldiers, let no excess on your part tarnish the glory of our arms. The orders heretofore issued in this department in regard to pillaging, marauding, the destruction of private property and stealing, and the concealment of slaves, must be strictly enforced.

It does not belong to the military to decide upon the relation of master and slave. Such questions must be settled by civil courts. No fugitive slave will, therefore, be admitted within our lines or camps except when especially ordered by the General commanding. Women, children, merchants, farmers, mechanics, and all persons not in arms, are regarded as non-combatants, and are not to be molested in their persons or property. If, however, they aid and assist the enemy, they become belligerents, and will be treated as such. If they violate the laws of war, they will be made to suffer the penalties of such violation.

Military stores and public property must be surrendered, and any attempt to conceal such property by fraudulent transfer or otherwise, will be punished; but no private property will be touched unless by orders of the General commanding.

Whenever it becomes necessary to levy forced contributions for the supply and subsistence of our troops, such levies will be made as light as possible, and be so distributed as to produce no distress among the people. All property so taken must be receipted and fully accounted for, as heretofore directed.

These orders will be read at the head of every regi-

ment, and all officers are commanded to strictly enforce them.

By command of Maj.-Gen. HALLECK.

N. H. McLEAN, Assistant Adjutant-General.

The effect of these military operations was a great excitement in the neighboring Confederate States. To witness their strongest positions for defence flanked and evacuated without a blow, to see other fortified points compelled to a quick surrender by an irresistible force of men and gunboats, revealed to them the gigantic contest in which they were engaged. They said: "No people were ever engaged in a more serious struggle. It is emphatically a combat for life or death." The Governor of Mississippi issued a proclamation calling upon every citizen able to bear arms to have his arms in readiness. Boards of police in all the counties of the State were required to appoint "enrollers" preparatory to drafting, and to establish gun shops to repair arms. The Governor of Arkansas issued a proclamation drafting into immediate service every man in the State subject to military duty, and requiring them to respond within twenty days. Gov. Harris of Tennessee issued a proclamation, saying: "As Governor of your State and Commander in Chief of its army, I call upon every able-bodied man of the State, without regard to age, to enlist in its service. I command him who can obtain a weapon to march with our armies. I ask him who can repair or forge an arm to make it ready at once for the soldier. I call upon every citizen to open his purse and his storehouses of provision to the brave defenders of our soil. I bid the old and the young, wherever they may be, to stand as pickets to our struggling armies." Thus was set on foot a system of measures which led to the passage of a conscription act by the Confederate Congress and the raising of an immense Confederate army during the ensuing summer months.

Meanwhile, on the morning of the 4th of March, an expedition consisting of the gunboats Louisville, Carondelet, St. Louis, Pittsburg, Lexington and four mortar boats, left Cairo for Columbus on the Mississippi. Transports with the following troops formed a part of the expedition: 42d and 27th Illinois, 6 companies of the 55th Illinois, four companies of the 71st Ohio and one company of the 54th Ohio. On arrival the fort was found to be unoccupied, except by two hundred and fifty of the 2d Illinois regiment, who had reached it by a land march a short time previous. The enemy had commenced the evacuation on the 26th ult. Almost everything difficult to move had been more or less destroyed. Still a large amount of army material was obtained. The enemy had retired down the river.

At Nashville order was speedily restored. Col. Matthews of the 51st Ohio was appointed provost marshal and the troops were all quartered without the city. An immense amount of military stores of the Confederate Government was found in the city. They consisted

of pork, beef, rice, corn and molasses. Gen. Buell removed his headquarters to the city, and the reserve of his army under Gen. McCook had arrived and were in quarters before the 2d of March.

This division in its progress had protected the railroad and repaired the bridges and roads on the route to Louisville. All of Gen. Buell's force was concentrated at Nashville and encamped along the different turnpikes leading from the city in a southerly direction at distances from two to five miles from the city, with pickets extending to the distance of ten miles.

Thus the Confederate line of defence from the Mississippi east to the mountains was swept away. The strongholds were evacuated and the less impregnable positions captured. There was nothing to withstand the triumphant march of the Federal forces southward over the country but the military force which might be gathered from the Confederate States. Was Tennessee therefore restored to the Union? Opposition presented itself everywhere. The Federal flag wherever waved was in the hands of individuals, and might indicate the true sentiments of the bearer, or might be upheld to cover and conceal the real disloyalty of his heart. Public bodies and representatives of established organizations made no such display. That Tennessee which one year previous reposed in peace under the folds of the national flag, now stood aloof and claimed that her allegiance was due to another power. This power she hoped would soon return and eject the invaders. Thus it was evident the territory was acquired by the Federal forces, but the hearty allegiance of the people would never be restored while the Confederate Government remained safe and strong in its seat at Richmond.

Meantime important events had taken place elsewhere. The military and naval expedition under Gen. Burnside was making important captures in the most populous and fertile part of the State of North Carolina. His force, being engaged at the time in active operations, was not included in the order of the President for a general advance. This army corps comprised three brigades. The first, under the command of Brig.-Gen. John G. Foster, consisted of the 23d, 24th, 25th and 27th Massachusetts, and the 10th Connecticut regiments; the second, under the command of Brig.-Gen. Jesse L. Reno, consisted of the 51st New York, 51st Pennsylvania, 21st Massachusetts, 6th New Hampshire, and 9th New Jersey regiments; the third, under the command of Brig.-Gen. John G. Parke, consisted of the 8th and 11th Connecticut, 58d and 89th New York, and a battalion of the 5th Rhode Island, together with battery F of the Rhode Island artillery. These three brigades numbered about 16,000 men and required more than 80 transports to take them to their destination—5 vessels to transport the horses, 8 or 10 to carry the supplies, a siege train and 2 pontoon bridge schooners, a divi-

sion hospital, and one for the signal corps. The naval portion of the expedition was under the command of L. M. Goldsborough, subsequently raised to the rank of rear admiral.

The chief of staff was Commander A. L. Case, staff medical officer, S. O. Jones, signal officer, H. G. B. Fisher. The names of the steam gunboats and of their commanders were as follows:

Name.	Guns.	Commander.	Rank.
Stars and Stripes	7	A. Herden	Lieut. Commanding.
Valley City	4	J. C. Chaplin	" "
Underwriter	3	N. Y. Jefford	" "
Hetzell	2	H. K. Davenport	Lieut. Com'dg.
Delaware	6	S. P. Quackenbush	" "
Shawshene	2	T. G. Woodward	Act. Master.
Lockwood	3	G. L. Graves	" "
Corus	2	J. McDermid	" "
Morse	2	Peter Hays	" "
Whitehead	1	Charles A. French	" "
J. N. Seymour	2	F. S. Welles	" "
Philadelphia	2	S. Reynolds	" "
Henry Brinker	1	J. E. Giddings	" "
Granite	1	E. Boomer	" "
General Putnam	2	McCook	Lieut. Com'dg.
Hunchback	4	E. R. Calhoun	Act. Lieut. Com.
Southfield	4	C. F. W. Rehm	Act. Vol. Lt. Com.
Com. Barney	2	B. D. Kenshaw	Act. Lt. Com.
Com. Ferry	2	Chas. W. Flusser	Lieut. Com'dg.
Total	51		

To these may also be added the Virginia, Louisiana, Young America, Jenny Lind. These steamers were of three classes: screw and side wheel tugs, navy screw gunboats, and armed ferry boats. Their armaments consisted chiefly of 30-pounder Parrotts rifled, and long smooth 32's, 64's, and some of much heavier caliber. A coast division of gunboats, with the transports, consisted of the Picket, 4 guns, Pioneer, 4 guns, Hussar, 4 guns, Vidette, 8 guns, Ranger, 4 guns, Chasseur, 4 guns.

The transport portion of the expedition was under the command of Samuel F. Hazard of the U. S. navy.

Nothing had been withheld that was necessary to secure success, and the accomplished officers, the disciplined and gallant men, and the abundant material awakened the most sanguine expectations on the part of the Government and the people.

The expedition sailed from Hampton Roads on the 12th of January, consisting of over 100 vessels of all classes.

The order to sail was issued on Saturday night the 11th, and by daylight on Sunday morning the largest portion of the fleet had passed outside the capes. Some vessels, and especially the water boats, refused to leave the capes. The first part of the day was pleasant, with a light wind from the southwest. During the afternoon it was thick weather, and the sailing vessels were generally obliged to cast off from the steamers and take care of themselves, and two or three of the canal boats, with hay and horses on board, broke away and were blown ashore. The expedition was bound to Hatteras Inlet, which is an entrance from the ocean to Pamlico Sound. It is a narrow passage with seven feet of water on the bar, and difficult to enter in rough weather without dan-

ger of grounding. The entrance to the inlet was commanded by two forts, which were captured by an expedition under Gen. B. F. Butler and Commodore Stringham during the preceding year. (*See ANNUAL CYCLOPEDIA, 1861—EXPEDITIONS.*)

The wind changed to the southeast and continued blowing in that quarter for several days after the vessels began to arrive. This brought in a considerable sea or swell, which made it dangerous for all the vessels drawing much water to cross the bar and attempt to enter except at the top of the tide. Those drawing the least water got in first, the others anchored outside watching an opportunity. In this perilous situation, with a high sea, a strong wind blowing on shore, and shoal water, with a crooked channel, several days passed during which the fleet was endeavoring one by one to get within the inlet. The steamer *City of New York* grounded on the bar, and the sea swept clean over her and quickly reduced her to a wreck. The gunboat *Zouave* sunk in the inlet, and two or three other small vessels were equally unfortunate. Within the inlet the anchorage was narrow and the change of the tide brought the vessels in contact, and the roughness of the water caused a constant chafing of rigging and spars, and crashing of bulwarks.

For two days the wind and sea were so high as to prevent all communication with the outer vessels, or with each other. The New Jersey regiment was then called to enter upon its work, with mourning in its ranks. Its Colonel, J. W. Allen, and its surgeon, F. S. Weller, were drowned by the overturning of a small boat in the breakers at the inlet.

The gale increased; dark clouds swept down from the east and seemed almost to touch the vessels' masts as they swayed to and fro. A single person here and there appeared on some vessel's deck, holding on by the rail or the rigging, and a few scattered groups of the soldiers who had been landed, were seen hurrying on the beach as if in search of shelter from the fury of the blast. The tents of the Massachusetts 24th, which had been pitched on the beach, were swept away, and the poor soldiers spent a fearful night, exposed to the peltings of a pitiless storm, with yet a more fearful night to follow. Even the brave commander of the expedition was heard to exclaim in suppressed tones, "This is terrible! When will the storm abate?"

This violent storm was followed by a high tide, and on the 24th, nearly all the vessels which had arrived were within the entrance, and by the 26th repairs had been made and the force was ready to move. Fortunately the few Confederate gunboats on the sound kept aloof and made no attack.

Preparations were now made for a speedy movement. The object was to proceed up Pamlico Sound, and open the passage into Albemarle Sound. This passage was called Croatan Sound, and was bounded on the one side by

the mainland and on the other by Roanoke Island, which is low and marshy. As this was the principal communication between Pamlico and Albemarle, the enemy had erected fortifications in the upper part of the passage, on Roanoke Island, and had also obstructed it by piles and sunken vessels. They had a fleet of seven small gunboats, prepared to contest the passage, and stationed near the batteries.

On the 8d of February, Gen. Burnside issued the following general orders:

HEADQUARTERS, DEPARTMENT OF NORTH CAROLINA,  
PAMLICO SOUND, February 8, 1862. }

GENERAL ORDERS, No. 5.

This expedition being about to land on the soil of North Carolina, the General Commanding desires his soldiers to remember that they are here to support the Constitution and the laws, to put down rebellion, and to protect the persons and property of the loyal and peaceable citizens of the State. In the march of the army, all unnecessary injuries to houses, barns, fences, and other property will be carefully avoided, and in all cases the laws of civilized warfare will be carefully observed.

Wounded soldiers will be treated with every care and attention, and neither they nor prisoners must be insulted or annoyed by word or act.

With the fullest confidence in the valor and the character of his troops, the General Commanding looks forward to a speedy and successful termination of the campaign.

By command of Brig.-Gen. A. E. BURNSIDE.  
LEWIS RICHMOND, Asst. Adj.-Gen.

Further orders relative to signals, and to the disembarkation of the troops, were issued on the next day.

Everything being ready, the forward movement commenced at half past seven on the morning of the 5th of February. The naval squadron following the flag officer's vessel, headed the fleet. Their course was at first southward, following the zigzag channel, until it finally became north by west. At regular and short intervals the gunboats filled their places in the line, and with scarcely perceptible motion, steadily stretched away to the horizon. Next came the transports and gunboats carrying the troops, consisting of sixty-five vessels, of all classes and characters. Each brigade formed three columns, headed by the flag ship of the brigade. Each large steamer had one, two, and in some instances, three schooners in tow. The aisles between the three columns of vessels were kept unbroken, through the whole length, which extended almost two miles over the surface of the sound, except by the two or three small propellers whose duty consisted in conveying orders.

At sundown the fleet came to anchor about ten miles from the southern point of Roanoke Island. The next morning, at eight o'clock, it was in motion. The preceding beautiful day was followed by a stormy one, and anchors were again dropped at the entrance of the inlet or strait. This was the day on which Fort Henry was taken. The next morning was clear, and the sun rose in a sky marked only with clouds enough to give it peculiar beauty. By ten o'clock all preparations had been made, and the

gunboats moved forward, entering the inlet. The flag ship of Gen. Burnside next followed, but the remainder of the transports were detained nearly two hours. A gun fired from one of the Confederate gunboats announced the approach of the Federal squadron. At half past eleven the conflict commenced between the gunboats at long range, but it was noon before they were engaged in close action. The Confederate boats gradually retired, drawing their opponents within range of the forts, when fire was opened by the latter.

The contest between the boats and the battery continued with varied energy during the next three hours, in which time the barracks within the forts were consumed. At three o'clock the troops began to land, under the protection of the fire of three of the gunboats. At this time the Confederate gunboats drew near and recommenced the action, which was continued until their ammunition was exhausted. They then retired up the inlet or sound. The battery continued to fire until the Union gunboats retired for the night. The bravery of the Confederate defence was admitted on every side. On the Federal side, five had been killed and ten wounded. In the fort, the Confederates reported one killed and three wounded, and in the gunboats five wounded, and the largest gunboat sunk, and another disabled.

By four o'clock the transports had all arrived, and the first body of troops were landed unobstructed at five o'clock. In a short time six thousand were on shore, and the remainder of the force landed soon after.

The next morning the troops started in three columns, the centre under Gen. Foster, composed of the 23d, 25th, and 27th Massachusetts, and 10th Connecticut; the next, or left flanking column, under Gen. Reno, consisted of the 21st Massachusetts, 51st New York, 9th New Jersey, and 51st Pennsylvania; the third, or right flanking column, under Gen. Parke, consisted of the 4th Rhode Island, first battalion of the 5th Rhode Island, and the 9th New York. The approach to the enemy was by a road through a swamp, on each side of which was a thick underbrush. An earthwork about thirty-five yards wide had been erected across the road for defence. The attack was bravely made, as it had been planned, upon the enemy's position, and after a most spirited and splendid defence, as reported by the assailants, they were obliged to give way before this overwhelming force, and retiring further up the island were overtaken, and Col. Shaw, their commander, surrendered. Thus six forts, forty guns, over two thousand prisoners, and three thousand stand of arms were captured. The Union loss was thirty-five killed and two hundred wounded. The Confederate loss in killed was reported to be sixteen, and wounded thirty-nine. The artillery of each side consisted of some heavy pieces, such as 100-pound Parretts, and a 100-pound Sawyer gun captured by the Confederates some time previous. The contest between

the battery and the gunboats, in the morning, was unimportant, and the latter proceeded to remove the obstructions in the channel.

On the reception of the report of Gen. Burnside at Washington the following order was issued by President Lincoln:

WASHINGTON, Feb. 15.

The President, Commander-in-Chief of the Army and Navy, returns thanks to Brigadier-General Burnside and Flag Officer Goldsborough, and to General Grant and Flag Officer Foote, and the land and naval forces under their respective commands, for their gallant achievements in the capture of Fort Henry and at Roanoke Island. While it will be no ordinary pleasure for him to acknowledge and reward in a becoming manner the valor of the living, he also recognizes his duty to pay fitting honor to the memory of the gallant dead. The charge at Roanoke Island, like the bayonet charge at Mill Springs, proves that the close grapple and sharp steel of loyal and patriotic citizens must always put the rebels and traitors to flight. The late achievements of the navy show that the flag of the Union, once borne in proud glory around the world by naval heroes, will soon again float over every rebel city and stronghold, and that it shall forever be honored and respected as the emblem of Liberty and Union in every land and upon every sea.

By order of the President.

(Signed) EDWIN M. STANTON,  
Secretary of War.

GIDEON WELLES, Secretary of the Navy.

On the afternoon of the next day after the surrender, Commodore Rowan, by order of Com. Goldsborough, with fourteen steamers, proceeded toward Elizabeth city. It is the capital of Pasquotank county, North Carolina, situated on the Pasquotank river, about twenty miles from its mouth and thirty miles from Roanoke Island. That night the fleet anchored about eighteen miles from the city. Next morning, the 10th, on approaching the town, seven Confederate gunboats and one schooner were discovered, and after a brief contest they retired under the guns of a small fort, were set on fire, and abandoned. This fort on Cobb's Point, mounting four guns, was also abandoned. At the same time the town was deserted by the Confederate forces, after having set on fire some of the houses, which were burned. All the Confederate gunboats were destroyed excepting one. Two were killed and about twelve wounded on the Union gunboats. The loss on the other side is not known. Commander Rowan immediately sent the gunboats Louisiana, Underwriter, Commodore Perry, and Lockwood, under Lieut. A. Maury, to Edenton, on the west end of Albemarle Sound. It is the capital of Chowan county and is at the head of Edenton bay, which opens into Albemarle Sound a little below the mouth of Chowan river. On the 12th the town was taken possession of by Lieut. Maury. Part of a light artillery regiment, from one to three hundred in number, withdrew without firing a gun. No fortifications existed, nor was any opposition made. Eight cannon and one schooner on the stocks were destroyed. Two schooners with four thousand bushels of corn were captured on the sound, and six bales of cotton taken from the custom house wharf.

On the next day, the 14th, Lieut. Jeffers was sent by Lieut. Maury with the gunboats Underwriter, Lockwood, Shawshene, and Whitehead, towing a couple of schooners to the mouth of the Chesapeake and Albemarle canal. The enemy were found engaged in placing obstructions in the mouth of the canal. These works were completed by sinking the two schooners and burning all that remained above water. This small expedition then returned to the mouth of North River. This was two days before the surrender of Fort Donelson. On the 18th of February the joint commanders of the Union forces in North Carolina issued the following proclamation, declaring to the people of that State the object of their mission :

ROANOKE ISLAND, NORTH CAROLINA, }  
February 18, 1862. }

*To the People of North Carolina :*

The mission of our joint expedition is not to invade any of your rights, but to assert the authority of the United States, and to close with you the desolating war brought upon your State by comparatively a few bad men in your midst.

Influenced infinitely more by the worst passions of human nature than by any show of elevated reason, they are still urging you astray to gratify their unholy purposes.

They impose upon your credulity by telling you of wicked and even diabolical intentions on our part; of our desire to destroy your freedom, demolish your property, liberate your slaves, injure your women, and such like enormities—all of which, we assure you, is not only ridiculous, but utterly and wilfully false.

We are Christians as well as yourselves, and we profess to know full well, and to feel profoundly, the sacred obligations of the character.

No apprehensions need be entertained that the demands of humanity or justice will be disregarded. We shall inflict no injury, unless forced to do so by your own acts, and upon this you may confidently rely.

Those men are your worst enemies. They, in truth, have drawn you into your present condition, and are the real disturbers of your peace and the happiness of your firesides.

We invite you, in the name of the Constitution, and in that of virtuous loyalty and civilization, to separate yourselves at once from these malign influences, to return to your allegiance, and not compel us to resort further to the force under our control.

The Government asks only that its authority may be recognized; and we repeat, in no manner or way does it desire to interfere with your laws constitutionally established, your institutions of any kind whatever, your property of any sort, or your usages in any respect.

L. M. GOLDSBOROUGH, Flag Officer,  
Commanding North Carolina Blockading Squadron.

A. E. BURNSIDE, Brigadier-General,  
Commanding Department of North Carolina.

It may be thought that this part of North Carolina was in a very defenceless condition. In many respects this was not so. It cost the United States two military and naval expeditions before it was reached. The first expedition, under the command of Gen. Benjamin F. Butler and Commodore S. H. Stringham, consisted of the steam frigates Minnesota and Washash, and armed steamers Monticello, Pawnee, and Harriet Lane, and the steam transports Adelaide and George Peabody, and the tug Fanny. The steam frigate Susquehanna also joined the expedition. The military force consisted of 880 men. These forces captured the

forts at the entrance of Hatteras Inlet, and made no further advance. The result of the expedition was the acquisition of the forts captured, the control of the island in which they were located, and the closing of the inlet against the passage of vessels running the blockade. The expedition under Gen. Burnside entered the inlet and captured the fortifications on Roanoke Island and destroyed the Confederate navy, when the country lay at its mercy. Small fortifications and some military force was found, however, at every town of any importance. No civil, commercial, or political changes were made such as to indicate that the inhabitants regarded themselves as restored to the Union. Those in whose hands was held the local civil and political power, retired to safe quarters upon the approach of the Federal force. They acknowledged another allegiance due to a power which they believed or hoped would yet be able to expel the Union troops. So long as that power retained its strength they either feared or declined to acknowledge allegiance elsewhere. That invariable follower of the invasion of hostile armies, the provost marshal, or military governor, attended the footsteps of the Burnside expedition as he has almost every other which has entered within the limits of the Confederate States during this year.

On the 19th of February a reconnoitring expedition left Edenton for Winton, the capital of Hereford county, situated near the head of navigation on the Chowan river, about fifty miles above its mouth. It consisted of the flotilla under the command of Commander Rowan and a company of Col. Hawkins' N. Y. regiment. This force had been informed at Elizabeth City, that five hundred Union men at Winton had raised "the Stars and Stripes" and desired protection. Upon arriving opposite the landing of the town, which was a short distance in the rear, a perfect shower of balls and buckshot were fired upon the advancing vessel. The river here is about a hundred yards wide and the banks high. The boats ascended and brought their guns to bear and fired several shells, and retired about eight miles down the river for the night. The next morning they returned and shelled the village. The military were landed and found it deserted, when the buildings were set on fire and burned.

The movements of the Federal forces caused efforts to be made by the State authorities to resist them. On the 22d Governor Clark issued the following proclamation :

NORTH-CAROLINIANS! Our country needs your aid for its protection and defence against an invading foe. The President of the Confederate States has made a requisition upon our State to complete her quota of troops in the field. Our own borders are invaded by the enemy in force, now threatening an advance to deprive us of liberty, property, and all that we hold dear, as a self-governing and free people. We must resist him at all hazards and by every means in our power. He wages a war for our subjugation—a war forced upon us in wrong and prosecuted without right, and in a spirit of vengeful wickedness without a parallel in the history of warfare among civilized nations.



As you value your rights of self-government and all the blessings of freedom—the hallowed endearments of home and fireside, of family and kindred—I call upon you to rally to their defence, and to sustain the noble and sacred cause in which we are engaged. North Carolina has always proved true, constant and brave, in the hour of trial and of danger. Never let it be said, that in the future she has failed to maintain her high renown. If we are threatened now more than heretofore, and upon our own soil, let our exertions be equal to every demand on our patriotism, honor, and glory. No temporary reverses dampened the ardor of your ancestors, even though the enemy marched in columns through the State. The fires of liberty still burned brightly in their breasts.

They were moved to new energy and resisted by gallant deeds, with abiding hope and unflinching courage and perseverance, bravely contending with enemies at home as well as the foreign foe, until, after a struggle of seven long years, our independence was achieved and acknowledged. Let us imitate their glorious example. The enemy is redoubling his efforts and straining every nerve to overrun our country and subjugate us to his domination—his avarice and ambition. Already it is proposed in their Congress to establish a territorial government in a portion of our State. Now is the time to prove our zeal and animate by example. I call upon the brave and patriotic men of our State to volunteer, from the mountains to the sea.

You are wanted both to fill up our quota in the confederate army and for the special defence of the State. I rely, with entire confidence, on a prompt and cheerful response to this call upon your patriotism and valor. Tender yourselves in companies and squads, under officers of your own selection. You will be at once accepted and organized into regiments under the laws that are or may be made, and which it is my duty to execute. The Adjutant-General will issue the necessary orders for this purpose.

Fellow citizens! Your first allegiance is due to North Carolina. Rally to her banners. Let every man do his duty and our country will be safe.

Given under my hand and the seal of the State, at Raleigh, this twenty-second day of February, 1862.

[SEAL] HENRY T. CLARK.

Preparations were now made by Gen. Burnside for an attack upon Newbern. This city is situated at the confluence of the Neuse and Trent rivers, about fifty miles from Pamlico Sound near its southern extremity. It is second in commercial importance in the State, and is connected by railroad with Raleigh the capital. On the 11th of March the troops intended for the expedition were embarked and ordered with the naval force to rendezvous at Hatteras Inlet. The latter force was under Commander Rowan, Com. Goldsborough having been ordered to Hampton Roads. These forces having combined left Hatteras the next morning and arrived about sunset at Slocum's Creek, eighteen miles below Newbern, and the place selected for disembarking the troops. The landing was effected the next morning with great enthusiasm under cover of the gunboats, and after a toilsome march of twelve miles through the mud, the head of the column reached, that evening, within a mile and a half of the Confederate stronghold. The remainder came up during the night with eight pieces of artillery, chiefly boat howitzers. The gunboats shelled the road in advance of the march of the troops, and covered their encampment at night. Early the next morning Gen. Foster's brigade was ordered by

Gen. Burnside to proceed up the main country road to attack the enemy's left, Gen. Reno up the railroad to attack the enemy's right, and Gen. Parke to follow Gen. Foster and attack the enemy in front, with instructions to support either or both brigades. The engagement which ensued continued for four hours, and resulted in carrying a continuous line of Confederate field work, over a mile in length, protected on the river flank by a battery of thirteen heavy guns and on the opposite flank by a line of redoubts over half a mile in length for riflemen and field pieces in the midst of swamps and dense forests. This line was defended by eight Confederate regiments of infantry, five hundred cavalry, and three batteries of field-artillery, each of six guns.

The position was finally carried by a brave charge, which enabled the Federal force to gain the rear of all the batteries between that point and Newbern. This was done by a rapid advance of the entire force up the main road and railroad, while the gunboats proceeded up the river throwing their shot into the forts and in front of the advancing forces. The enemy in retreating destroyed the country road bridge and the draw of the railroad bridge over the river Trent, thus preventing pursuit, and escaped by the railroad. Meantime the gunboats arrived at the wharves and commanded the city, but it was not occupied by the troops until Gen. Foster's brigade was brought up by the vessels. Thus eight batteries containing forty-six heavy guns, three batteries of light artillery containing six guns each, two steamboats, a number of sailing vessels, wagons, horses, a large quantity of ammunition, commissary and quartermasters' stores, forage, and two hundred prisoners were captured. The Union loss was ninety-one killed and four hundred and sixty-six wounded. The Confederate loss was severe, but not so great, as they were effectually covered by their works. They retired to Tuscarora about ten miles from Newbern. Gen. Gatlin being indisposed, they were commanded by Gen. O. B. Branch.

On the next day Gen. Burnside issued the following address to his force:

HEADQUARTERS, DEPT. OF NORTH CAROLINA, }  
NEWBERN, March 15.

*General Order, No. 17.*

The General Commanding congratulates his troops on their brilliant and hard won victory of the 14th. Their courage, their patience, their endurance of fatigue, exposure and toil, cannot be too highly praised.

After a tedious march, drawing their howitzers by hand through swamps and thickets, after a sleepless night, in a drenching rain, they met the enemy in his chosen position, found him protected by strong earthworks, mounting many and heavy guns, and in an open field themselves—they conquered. With such soldiers, advance is victory.

The General Commanding directs with peculiar pride, that, as a well-deserved tribute to valor in this second victory of the expedition, each regiment engaged shall inscribe on its banner the memorable name "Newbern."

By command of Brigadier-General

A. E. BURNSIDE.

Lewis Richmond, Adjutant-General.



On the 20th Gen. Parke's brigade commenced to march from Newbern for Beaufort, and on the 23d entered Moorhead city, thirty-six miles from Newbern, and found it evacuated. It is a short distance from Beaufort and connected by a steam ferry. A flag of truce was then sent over to Fort Macon, and a surrender demanded. This was refused, and vigorous measures were at once commenced to reduce it by a siege. Beaufort is the capital of Carteret county, situated at the mouth of Newport river, and a few miles from the sea. The harbor is the best in the State, and its entrance is defended by Fort Macon.

Meanwhile, on the 20th, a naval column consisting of the gunboats Louisiana, Delaware, and Com. Perry, with the transport Admiral, having on board eight companies of the 24th Massachusetts regiment, proceeded to Washington, a small town on the left bank of the Tar river about forty miles from Pamlico Sound. On the 25th, the force arrived before the town, and were received by the authorities without opposition. Below the town obstructions had been placed in the river, and abandoned fortifications were found on each shore adjacent. The commander, A. Maury, thus reported to his superior officer: "I found on further consultation with the authorities, on whom I made my demand for the restoration of the Hatteras Light property, that underlying an apparent acquiescence of the people of the town and neighborhood, in permitting the building of gunboats, and the construction of batteries to repel the approach of the Federal forces, was a deep-rooted affection for the old Union, and not a little animosity for its enemies; the latter element not being diminished by the importation of troops from a distant State. The result of this state of affairs was, as could be anticipated, the abandonment of its defences by the troops, followed by the destruction of what remained of Confederate property by the people. The launched gunboat had been towed several miles up the river, loaded with turpentine, and fired on the night of our arrival. A few hundred bushels of meal and corn left in the commissary store, were distributed to the poor by my orders. All the Hatteras Light property in the town was secured. The woods and swamps were represented as being alive with refugees from the draft. Many of them, encouraged by our presence, came in. They were bitter and deep in their denunciations of the secession heresy, and promised a regiment if called to aid in the restoration of the flag." This force returned to Newbern.

The force in the neighborhood of Fort Macon, however, was not idle. A detachment from Gen. Parke's brigade, consisting of the 4th Rhode Island and 8th Connecticut, on the night of the 25th, crossed over and took possession of Beaufort without opposition. In the day time this passage would have been resisted by the fort. No military force was found in the town. Preparations were now made se-

riously to invest the fort. All communication by land or water was cut off, and guns were put into position to reduce it. The garrison consisted of nearly five hundred men under command of Col. White. The regular siege operations commenced on the 11th of April, when a reconnoissance in force was made by Gen. Parke. The pickets of the enemy stationed on Bogue Beach, two miles from the fort, were driven in and a good situation for the siege guns was found. Everything being in readiness, on the morning of the 25th of April, fire was opened upon the fort from a breaching battery eleven hundred feet distant, and flanking mortars planted at a distance of about fourteen hundred yards, and behind sand banks which prevented the garrison from seeing them before the fire was opened. At the same time the blockading gunboats Daylight, Commander Lockwood; State of Georgia, Commander Armstrong; Chippewa, Lieut. Payson and bark Gemsbok, Lieut. Caverdy; approached the fort and began to fire. The three steamers assisted the bark, and kept under way, steaming round in a circle and delivering their fire as they came within range, a mile and a quarter distant from the fort. After an hour and a quarter, the sea became so rough and their fire consequently so inaccurate, that the fleet retired. The action however continued between the batteries and the fort until toward evening, when the latter was surrendered with the honors of war. All the guns on the side of the fort opposite that attacked, were dismounted, and also all but three of those bearing upon the Federal force, when it became untenable. The firing of the fleet did no injury to the fort. The Daylight was struck by an 8-inch solid shot which entered her quarter. Seven of the garrison were killed and eighteen wounded. One was reported killed on the Federal side.

While this siege was pressed forward, Gen. Burnside, in order to create the impression at Norfolk, Va., that he was approaching with his whole force, sent Gen. Reno with the 21st Massachusetts, 51st Pennsylvania, a part of the 9th and 89th New York, and 6th New Hampshire in that direction. Proceeding nearly to Elizabeth City, he disembarked at a point about three miles below, on the night of the 19th of April. Col. Hawkins was ordered forward with the 9th and 89th New York and the 6th New Hampshire toward South Mills, to be followed by Gen. Reno four hours after, upon getting the remaining troops ashore. Col. Hawkins lost his way and came in behind Gen. Reno on the march, and was ordered to follow. Having marched about sixteen miles, and within a mile and a half of South Mills, a Confederate force opened with artillery upon the advanced guard before it was discovered. They were found posted across the road, with their infantry in ditches, and their artillery commanding all the direct approaches. Their rear was protected by a dense forest. Gen. Reno or-

dered the 6th New Hampshire to form in a line on the left of the road and support the four pieces of artillery, while the 51st Pennsylvania and 21st Massachusetts filed to the right and passed over to the edge of the wood to turn the enemy's flank, and the New York regiments supported them. The effect of these movements, and the sharp firing that ensued, caused the enemy soon to retire in a rapid manner. The force rested until evening, and then withdrew to their boats. The Federal loss was fourteen killed and ninety-six wounded, and two taken prisoners. The Federal force remained on the field for seven hours, buried their dead, and transported all the wounded except fourteen, so severely wounded that they could not be moved, but who were comfortably provided for and left in charge of a surgeon and chaplain. "In obedience to orders," says Gen. Burnside, "Gen. Reno then returned to his fleet and embarked his men." Ten or fifteen prisoners were taken, most of whom belonged to the 3d Georgia regiment. The loss of the Confederate force was unknown; thirty killed and wounded were left on the field. They reported one regiment and three pieces of artillery as the entire force engaged.

On the 23d of April, a naval expedition consisting of the gunboats Lockwood, Whitehead, and Putnam, under Lieut. Flosser, was sent to obstruct the entrance of the Dismal Swamp canal. This was done by means of sinking a schooner, and filling the canal with brush, stumps, rails, and earth, and trunks of trees.

On the 6th of June, a sharp engagement occurred eight miles from Washington near Pactolus, between a Confederate force under Col. Singleterry and the 24th Massachusetts under Capt. Potter. This latter officer had been stationed at Washington with a small force, and hearing of the gathering of the enemy, obtained reinforcements, and successfully attacked them. Seven were killed and eleven wounded on the Federal side.

Some other military movements, to be hereafter stated, took place during the succeeding months. This portion of North Carolina was held by the Union forces throughout the year. Its ports were closed to imports for the Confederate States, and its commerce ceased entirely. (See NORTH CAROLINA.) The principal part of the forces under Gen. Burnside were subsequently brought to Newport News, where they remained in transports until the Army of the Potomac returned to Alexandria. They then united with it under Gen. Pope.

This expedition in its outfit, vigor of action, and complete achievements, showed that it was commanded by an experienced, judicious, and able officer. It was necessarily confined in its operations to the shores of the country, where it could act in concert with the gunboats. Public expectation had looked forward to see it penetrate the State of North Carolina, and occupy the eastern line of railroad connecting the Southern States with Richmond. It never

was strong enough to entertain such a thought. Brave old North Carolina has always had a high reputation for soldiers. Her white population is over six hundred thousand, and her militia must have been nearly one sixth of this number. Gen. Burnside's military force was about sixteen thousand strong. His expedition had not been in the field four months, when the Government found itself entirely without soldiers who could be sent to reinforce him.

The achievements of the military and naval expedition to the coast of South Carolina and Georgia, should be described in this connection. For an account of its outfit, departure, and occupation of Hilton Head and adjacent islands, see ANNUAL CYCLOPEDIA, 1861—EXPEDITIONS. Undoubtedly there was a double object in this expedition. On the one hand it was designed to seize and hold as large a district of the coast as might be practicable, and on the other prepare a base for future operations against Charleston and Savannah, South Carolina, and the great State of Georgia. The point designed for its headquarters, and for the base of future operations, was occupied at once. The first labor was to prepare Port Royal for the purposes in view. Immense cargoes of commissary stores, ordnance, and means of transportation were landed from the large ocean steamers which accompanied the expedition. Extensive warehouses were erected for the preservation of the stores; while for the security of the depot whence supplies were to be drawn for all portions of the command, and to enable as many troops as possible to be spared for distant operations, long lines of defence had to be constructed. While the works were pushed forward reconnoissances were made in every direction to ascertain the position and strength of the enemy, to learn the depth of water in the numerous creeks and inlets, and remove all obstructions that might have been placed in important channels of communication.

At the beginning of the year it was observed to be the design of the enemy to shut up the Federal troops in Port Royal Island, by placing obstructions in Coosaw river and Whale Branch, by constructing batteries at Port Royal Ferry, at Seabrook, and at or near Boyd Creek, and by accumulating men in the vicinity so as to be able to throw a force of twenty-five hundred or three thousand upon any of these points, at a short notice. It was determined to arrest their designs peremptorily, and in such a manner as would serve a subsequent purpose. Commander E. R. P. Rodgers had charge of the naval force of the expedition, consisting of the gunboats Ottawa, Lieut. Stevens, Pembina, Lieut. Bankhead, and four armed boats of the Wabash, carrying howitzers, and under the command of Lieuts. Upsher, Lane, Irwin, and Master Kempff, which were to enter the Coosaw by Beaufort river; and the gunboat Seneca, Lieut. Ammen, and tug boat Ellen, Master Budd, which were to move up Beaufort river, and approach the batteries at Seabrook and

Port Royal Ferry by Whale Branch. The tug boat E. B. Hale, Master Foster, was added to the expedition after it started. The part assigned to the naval force was to protect the landing of the troops at Haywood's plantation, the first point of debarkation, to cover the route of the advancing column, and the second point of debarkation, and to assail the batteries on their front. The military force consisted of the 47th and 48th New York regiments, Cols. Frazer and Perry, the 79th New York, 50th and 100th Pennsylvania, and 8th Michigan, with a naval howitzer force of forty men, under Lieut. Irwin. After the forces, landed at the two points, had marched, driving all of the enemy who were seen before them, and formed a junction, they were divided into centre, right, and left wings, and ordered forward to attack the batteries of the enemy. A sharp skirmish of half an hour ensued upon their approach to the battery, when the enemy retired, and the works were completely destroyed. An incomplete work at Seabrook, two miles from Port Royal Ferry, was destroyed at the same time. The result of the expedition was the destruction of the two batteries, driving the enemy five miles into the rear, and rendering the Broad and Coosaw rivers secure for the gunboats. The land force was commanded by Gen. Stevens. Eleven privates were wounded and two of them missing. Four of the enemy were found dead.

While all the improvements were urged forward at Hilton Head, reconnaissances were constantly made. The next movement of interest

took place on the 26th of January, in consequence of explorations which had been previously made, and which were of such an adventurous nature as to entitle to honor the parties engaged. The city of Savannah is about fifteen miles from the mouth of the river of that name, and situated on its right or southern bank. The approach to it by water is defended by Fort Pulaski (*see ANNUAL CYCLOPEDIA, 1861—FORTS*), a casemated work on Cockspur Island, at the mouth of the river, and Fort Jackson, a barbette work on the mainland, only four miles below the city. The left bank of the river is formed by a succession of islands, and the channel is also interrupted by large and numerous ones. The network of creeks and bays which surround Hilton Head terminates to the southward in Calibogue Sound, which is separated from Savannah river at its mouth by Turtle and Jones Islands. The waters that bound two sides of Jones Island, which is triangular in shape, are called Mud and Wright rivers; the latter is the more southern, and separates Jones from Turtle Island, which lies next to Dawfuskie Island, the western shore of Calibogue Sound. The water on the third side of Jones Island is the Savannah river. This island is about five miles long, and between two and three broad. About half way between its upper and lower angles, and fronting on the Savannah, is Venus Point, where a Federal battery was subsequently placed to cut off communication between Savannah and Fort Pulaski.

Lieut. J. H. Wilson, of the topographical

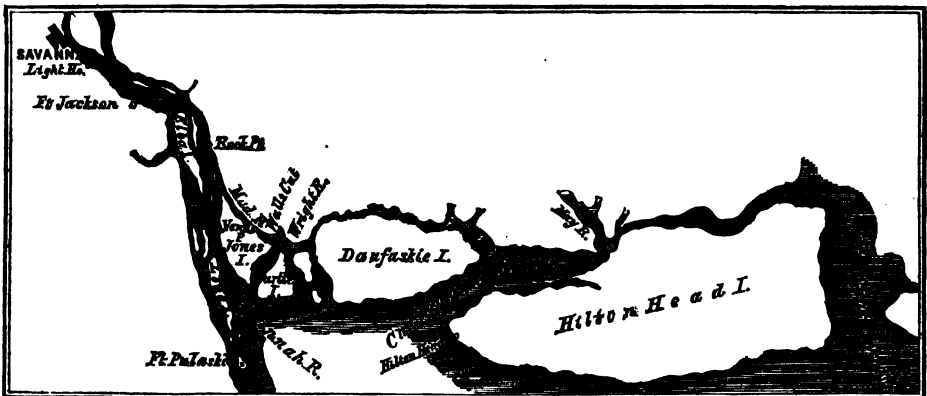

engineers, becoming convinced, from information obtained of negro pilots and others, that an interior passage existed, connecting Calibogue Sound with the Savannah river, and which, if passable by gunboats, might lead to cutting off Fort Pulaski from communication with Savannah, was despatched by Gen. Sherman on a reconnoissance. Taking with him two row boats, and about seventy men of the Rhode Island regiment, he left Calibogue Sound with his negro crew and pilots, and ventured by night through the intricate passages. At this time

the Union troops had not advanced beyond Dawfuskie Island, and on some of these rivers Confederate pickets were still stationed. The oars of the reconnoitring party, however, were muffled, and they passed by the pickets without discovery. Under cover of the darkness they penetrated several miles up one of these streams, leaving the pickets in their rear. If discovered, retreat or escape would have been impossible for them, as there was no opportunity of returning except on the same route by which they came. The river which they thus

explored led into no other channel, but wasted away in a marsh. They got back into another stream. Finally the creeks became so shallow as to be unnavigable for any but the smallest craft. At one point an artificial channel had been constructed about two hundred yards long, called Wall's Cut. This led to the rear of Jones Island, and into both the Mud and Wright rivers, both of which, as stated above, empty into the Savannah, the former about six miles, and the latter about two miles above Fort Pulaski. This cut had, however, been obstructed by three rows of piles driven across its entire width, and by a large brig sunk in the same direction, across the channel. At high tide the reconnoitring party were able to get over the piles and pass the brig. The reeds on both banks were very high, and the cut altogether invisible from Savannah, while the marshy nature of the region prevented any approach by land. There was danger of meeting pickets or stray parties of sportsmen, shooting wild ducks abounding in those waters. The party remained concealed by the reeds during the day, and at night pursued their explorations. They found the channel of Mud river impassable for large vessels by reason of its shallow water, but got easily through the Wright river, and rounding the point of Jones Island, entered the Savannah. There they remained nearly all night, moving at times under the guns of Fort Pulaski, near enough to hear the challenge of the lonely sentinels, or the conversation of the gunners on the parapets before tattoo. They found the depth and bearings of the channel in all directions; went up the river beyond Venus Point, and even passed the entrance of Mud river, and then returned into the Wright, establishing to their own satisfaction that gunboats of ten feet draught could pass by that route into the Savannah, without incurring any material risk from the guns of Pulaski, which were at the nearest point a mile and three-fourths distant.

Upon this report Gen. Sherman caused another and fuller reconnoissance to be made. Major Beard of the 48th New York was sent to remove the obstructions in Wall's Cut. A party of volunteer engineers and a company of the 7th Connecticut accompanied him; and while some kept a careful watch, others were engaged at the obstructions. They were removed in three weeks of unremitting night labor. All the piles were sawn off a foot below the bottom of the cut, and the brig turned lengthwise, leaving a passage wide enough for the gunboats. All this was accomplished without awakening the suspicions of the enemy, whose pickets had been withdrawn. All stragglers, white or black, who approached were seized; of these, four or five whites seemed to have been hunting, for they were in boats loaded with game; others were slaves who had escaped from Savannah. All were astonished to see their captors there. No scouts were ever detected, and no boats passed on the Savannah river except the steamers

plying to Fort Pulaski from Savannah. On some nights the rain fell furiously, but the work proceeded. After the obstructions had been removed, a violent storm that lasted for several days rendered any further operations impracticable; still the pickets kept up their watch on the dismal and muddy marsh, and every straggler or spy was seized.

A naval reconnoissance was now made by Capt. John Rodgers and Lieut. Barnes, in company with Lieut. Wilson. Like all the others it was made in the night. The party were able to pass through the cut, take soundings in the Wright river, enter the Savannah, and ascertain all that was necessary to determine the practicability of the passage of gunboats. Capt. Rodgers reported favorably, and was willing to command the movement. It was determined therefore that a reconnoissance in force should be made, and preparations were commenced for that purpose.

It had always been known that a passage existed on the right side of the Savannah, leading from Warsaw Sound through the Wilmington river until it narrows into St. Augustine Creek, and finally empties into the Savannah just below Fort Jackson. This passage was defended by a battery. Information was however obtained from negroes of another passage leading up also from Warsaw, but much nearer to the Savannah and entering it lower down than St. Augustine Creek. This second passage is called Wilmington Narrows. Several reconnoissances were made along its course and the result was a determination by Gen. Sherman and Com. Dupont to send a force up Wilmington Narrows, at the same time that operations should begin in the vicinity of Wall's Cut. Accordingly on the 28th of January, Gen. Wright with the 4th New Hampshire, Col. Whipple, 6th Connecticut, Col. Chatfield, and 97th Pennsylvania, Col. Guess, on the transports Cosmopolitan, Boston, and Delaware were convoyed by the gunboats Ottawa, Seneca, and others under Capt. C. H. Davis to Warsaw Sound. The force then proceeded up the Wilmington Narrows for some miles and in the rear of Fort Pulaski until it arrived at a place where piles had been placed to obstruct its further progress. The gunboats remained at this spot a short distance from the Savannah during the night, while reconnoissances were made on land and water. In the morning Capt. John Rodgers with three gunboats appeared on the opposite side of the Savannah in Wall's Cut. Two of these vessels passed into Wright river. About eleven o'clock in the forenoon Com. Tatnall and the five Confederate steam gunboats attempted to pass down the river with scows in tow, when fire was opened upon them by the gunboats on each side. The country on each side is so flat that but little obstruction to the sight intervened. In less than half an hour Com. Tatnall and one of his vessels were driven back; the other three escaped injury apparently and made

good their passage down to Fort Pulaski. They returned at low water and escaped uninjured. The objects of the reconnaissance being now attained the forces returned to Hilton Head. The gunboats in Wright river did not go down as far as the entrance to the Savannah, as they would be in reach of the guns of Fort Pulaski, and Capt. Rodgers feared that they might get aground. This withdrawal of the boats from Wall's Cut was regarded by the Confederate commander as an abandonment of the purpose to enter the Savannah by that route. Confidence was thus restored in the minds of the citizens of Savannah, and the wisest hoped that the fort, which was the key of the city, might be enabled to detain their enemy for an indefinite length of time. The greatest consternation therefore prevailed in Savannah when the fort was ultimately captured.

Gen. Sherman now commenced a series of measures by which to cut off all communication between the city and the fort. This consisted in the planting of batteries on the river. The most important one was at Venus Point on the river side of Jones Island. A road was made with almost herculean labor across its marshy surface from Wall's Out, by the 48th New York regiment. Over this road the cannon were brought and placed in the battery. An attack was made on this battery by the Confederate gunboats on the 14th of March. After an engagement of an hour they were driven off. Another battery was placed on the extremity of Long Island, which was on the other side of the channel of the river, and still another was placed on floats at the mouth of Mud river. Some weeks were passed before this work was done and the communication entirely cut off. Preparations were next commenced for the reduction of the fort. This was to be done by batteries established on Tybee Island adjacent to Cockspar Island, on which the fort is located. These were not completed until the 9th of April, when the following order for the bombardment of the fort was issued:

*General Orders—No. 17.*

HEADQUARTERS UNITED STATES FORCES, }  
TYBEE ISLAND, GA., April 9, 1862. }

The batteries established against Fort Pulaski will be manned and ready for service at break of day tomorrow.

The signal to begin the action will be one gun from the right mortar of Battery Halleck (2,400 yards from the work), fired under the direction of Lieutenant Horace Porter, chief of ordnance; charge of mortar 11 lbs., charge of shell 11 lbs., elevation 55°, and length of fuse 24<sup>ft</sup>.

This battery (two 13-inch mortars) will continue firing at the rate of fifteen minutes to each mortar alternately, varying the charge of mortars and length of fuse, so that the shells will drop over the arches of the north and northeast faces of the work, and explode immediately after striking, but not before.

The other batteries will open as follows, viz:

Battery Stanton (three 13-inch mortars, 3,400 yards distant), immediately after the signal, at the rate of fifteen minutes for each piece, alternately from the right; charge of mortar 14 lbs., charge of shell 7 lbs.,

elevation 45°, and length of fuse 23°, varying the charge of mortar and length of fuse as may be required. The shells should drop over the arches of the south face of the work, and explode immediately after striking, but not before.

Battery Grant (three 13-inch mortars, 3,200 yards distant), immediately after the ranges for Battery Stanton have been determined, at the rate of fifteen minutes for each piece, alternately from the right; charge of shell 7 lbs., elevation 45°, charge of mortar and length of fuse to be varied to suit the range, as determined from Battery Stanton. The shells should drop over the arches of the south face of the work, and explode immediately after striking, but not before.

Battery Lyon (three 10-inch columbiads, 3,100 yards from the work), with a curved fire, immediately after the signal, allowing ten minutes between the discharges for each piece, alternating from the right; charge of guns 17 lbs., charge of shell 8 lbs., elevation 20°, and length of fuse 20°; the charge and length of fuse to vary as required. The shell should pass over the parapet and into the work, taking the gorge and north face in reverse, and exploding at the moment of striking, or immediately after.

Battery Lincoln (three 8-inch columbiads, 3,045 yards from the work), with a curved fire, immediately after the signal, allowing six minutes between discharges for each piece, alternating from the right; charge for gun 10 lbs., charge of shell 1½ lbs., elevation 20°, and length of fuse 20°, directed the same as Battery Lyon, upon the north face and gorge in reverse, varying the charge and length of fuse accordingly.

Battery Burnside (one 13-inch mortar, 2,750 yards from the work), firing every ten minutes, from the range as obtained for Battery Sherman; charge of shell 7 lbs.; elevation 45°; charge of mortar and length of fuse varying as required from those obtained for Battery Sherman. The shells should drop on the arches of the north and northeast faces, and explode immediately after striking, but not before.

Battery Sherman (three 10-inch mortars, 2,650 yards from the work), commencing immediately after the ranges for Battery Grant have been determined, and firing at the rate of fifteen minutes for each piece, alternating from the right; charge of shell 7 lbs.; elevation 45°; charge of mortar and length of fuse to be fixed to suit the range as determined from Battery Grant. The shells should drop over the arches of the north and northeast faces.

Battery Scott (three 10-inch and one 8-inch columbiads, 1,677 yards from the work), firing solid shot and commencing immediately after the barbette fire of the works has ceased. Charge of 10-inch columbiads 20 lbs., elevation 41°; charge of 8-inch columbiad 10 lbs., elevation 5°. This battery should breach the pan coupé between the south and southeast faces, and the embrasure next to it in the southeast face: the elevation to be varied accordingly, the charge to remain the same. Until the elevation is accurately determined each gun should fire once in ten minutes; after that, every six or eight minutes.

Battery Sigel (five 30-pounder Parrotts and one 24-pounder James', 1,620 yards from the work), to open with 41° fuse on the barbette guns of the fort at the second discharge from Battery Sherman. Charge for 30-pounders, 3½ lbs.; charge for 24-pounder, 5 lbs.; elevation, 40° for both calibers.

As soon as the barbette fire of the work has been silenced, this battery will be directed, with percussion shells, upon the walls, to breach the pan coupé between the south and southeast face, and the embrasure next to it in the southeast face, the elevation to be varied accordingly, the charge to remain the same. Until the elevation is accurately determined, each gun should fire once in six or eight minutes; after that, every four or five minutes.

Battery McClellan (two 42 and two 32-pounder James', 1,620 yards from the work) opens fire immediately after Battery Scott. Charges for 42-pounder, 8 lbs.; charge for 32-pounder, 6 lbs.; elevation of 42-

pounder, 41°, and 32-pounder, 4°. Each piece should fire once every five or six minutes after the elevation has been established, charge to remain the same. This battery should breach the works in the pancoupé between the south and southeast faces, and the embrasure next to it in the southeast face. The steel scraper for the grooves should be used after every fifth or sixth discharge.

Battery Totten (four 10-inch siege mortars, 1,685 yards from the work) opens fire immediately after Battery Sigel, firing each piece about once in five minutes; charge of mortar, 3½ lbs.; charge of shell, 3 lbs.; elevation, 45°; and length of fuse, 13½". The charge of mortar and length of fuse vary, so as to explode the shell over the northeast and southeast faces of the work.

If any battery should be unmasked outside the work Battery Totten should direct its fire upon it, varying the charge of mortars and length of fuse accordingly.

The fire from each battery will cease at dark, except special directions be given to the contrary.

A signal officer at Battery Scott, to observe the effects of the 13-inch shells, will be in communication with other signal officers stationed near Batteries Stanton, Grant, and Sherman, in order to determine the range for these batteries in succession.

By order of Brig.-Gen. Q. A. GILMORE.

Before the bombardment was commenced on the 10th, the fort was summoned to surrender. The following is the correspondence:

HEADQUARTERS DEPARTMENT OF THE SOUTH, }  
TYBEE ISLAND, GA., April 10, 1862. }

To the Commanding Officer, Fort Pulaski:

SIR: I hereby demand of you the immediate surrender and restoration of Fort Pulaski to the authority and possession of the United States.

This demand is made with a view to avoiding, if possible, the effusion of blood which must result from the bombardment and attack now in readiness to be opened.

The number, caliber, and completeness of the batteries surrounding you, leave no doubt as to what must result in case of refusal: and as the defence, however obstinate, must eventually succumb to the assailing force at my disposal, it is hoped you will see fit to avert the useless waste of life.

This communication will be carried to you under a flag of truce by Lieut. J. H. Wilson, United States Army, who is authorized to wait any period not exceeding thirty minutes from delivery for your answer.

I have the honor to be, sir, your most obedient servant,  
DAVID HUNTER,

Major-General Commanding.

Gen. Hunter had been placed in command of the Federal forces, and Gen. Sherman, before completing the enterprises he had commenced, was recalled. The Confederate commander of the fort replied to this demand as follows:

HEADQUARTERS, FORT PULASKI, April 10, 1862.

Maj.-Gen. David Hunter, commanding on Tybee Island:

SIR: I have to acknowledge receipt of your communication of this date, demanding the unconditional surrender of Fort Pulaski.

In reply I can only say that I am here to defend the fort, not to surrender it.

I have the honor to be, very respectfully, your obedient servant,  
CHAS. H. ÖLMSTEAD,

Colonel First Volunteer regiment of Georgia, commanding post.

On this refusal, and at twenty-three minutes of eight o'clock in the morning the fire was opened. Three minutes after the fort replied from a 10-inch barbette gun, and soon after the firing became general on both sides. After eighteen hours the fort was breached in the southeast

angle, and at the moment of surrender, 2 o'clock P. M. of the 11th, preparations had been commenced for storming. Forty-seven guns, a great supply of fixed ammunition, forty thousand pounds of powder, and large quantities of commissary stores, and three hundred and sixty prisoners were taken.

It was expected at Savannah that an attack would be immediately made upon Fort Jackson, to be followed by its surrender, and that of the city also. Nothing of the kind, however, was contemplated. The Union commander was in no condition to undertake such an enterprise, and actually was obliged to content himself with holding what had been acquired. The possession of Fort Pulaski prevented any further attempts to run the blockade into Savannah by the mouth of the river.

While these operations had been going on against Fort Pulaski, the other portion of the military and naval forces at Hilton Head had not been idle. On the 28th of February Com. Dupont sailed from Port Royal in the steam frigate Wabash, accompanied by the following vessels: Ottawa, Mohican, Ellen, Seminole, Pawnee, Pocahontas, Flag, Florida, James Adger, Bienville, Alabama, Key Stone State, Seneca, Huron, Pembina, Isaac Smith, Penguin, Potomska, armed cutter Henrietta, armed transport McClellan, the latter having on board the battalion of marines under the command of Maj. Reynolds, and the transports Empire City, Marion, Star of the South, Belvidere, Boston, and George's Creek, conveying a brigade under the command of Brig.-Gen. Wright.

On the 2d of March the expedition came to anchor in St. Andrew's Sound, and on the next morning a portion of the gunboats and transports, under Commander Drayton, proceeded down Cumberland Sound toward Fernandina on the north extremity of Amelia Island. Cumberland Sound is the passage between Cumberland Island and the mainland. Amelia Island is next in order below Cumberland Island; the north point of the former and the south point of the latter being nearly opposite. The remainder of the fleet proceeded down outside to the entrance between Cumberland and Amelia Islands. The object of sending a portion of the fleet through Cumberland Sound was to turn the works on the south end of Cumberland and the north end of Amelia Islands. The enemy having received information of the expedition, abandoned their works on its approach and retired. Fort Clinch on Amelia Island was taken possession of and garrisoned. The town of Fernandina, which was almost deserted, was occupied by the Union force, and a small steam boat loaded with stores was overtaken and captured. The Confederate force stationed at Fernandina consisted of the 4th Florida, Col. Hopkins, with a number of companies of cavalry and light artillery. Reconnoitring expeditions were sent out in different directions with successful results. New Fernandina on Amelia Island, about a mile and a half from Old Fer-



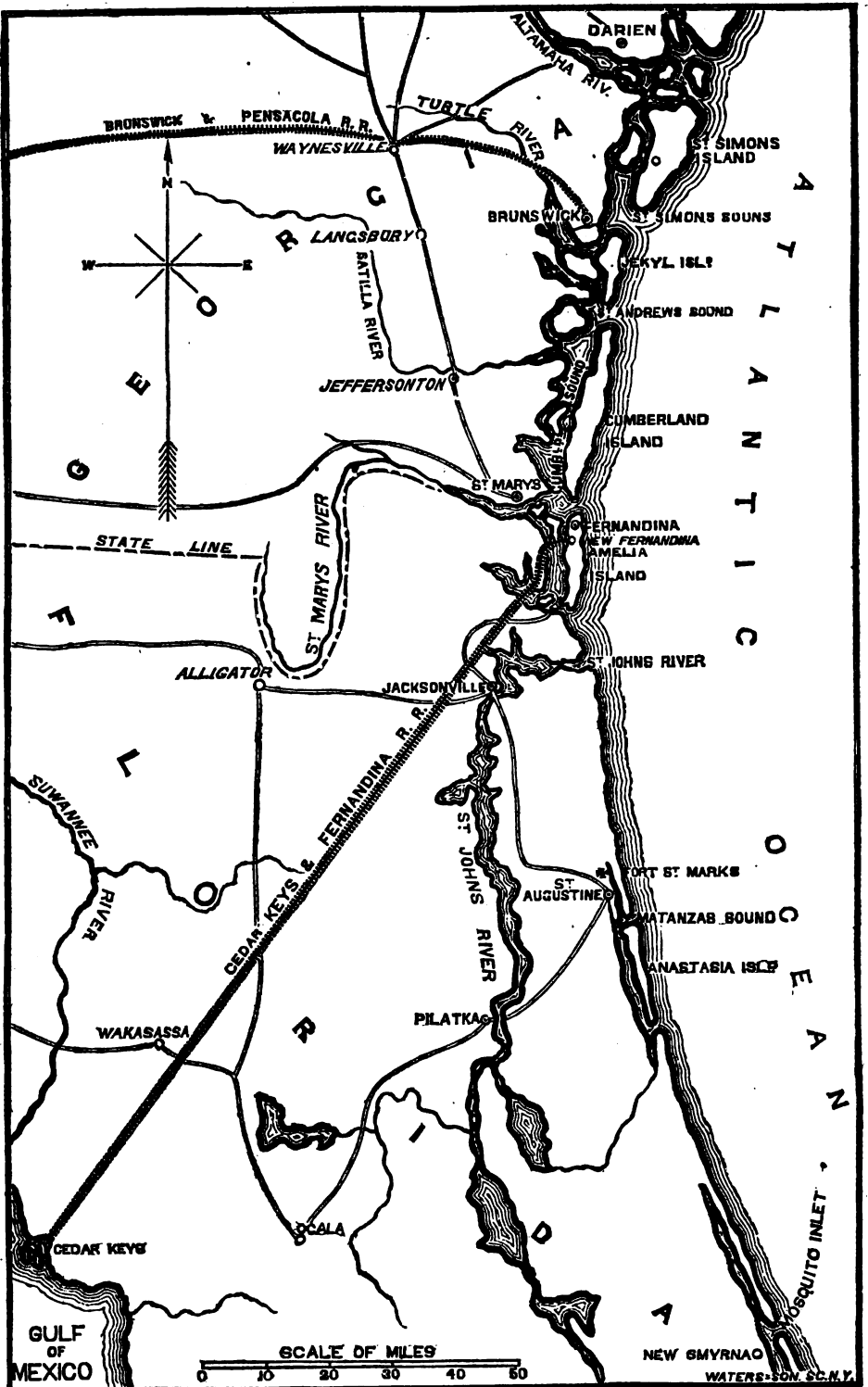

nandina, is the eastern termination of the railroad across the peninsula. The western termination is Cedar Keys, a small town located on one of a group of small islands close to the west coast of Florida. It was captured by a Union force on the 16th of January. On the same night that Fernandina was taken Commander E. R. P. Rodgers in the Ottawa ascended the St. Mary's river, and took possession of the town of that name, driving out a picket of the enemy's cavalry. This town and Fernandina were uninjured. Preparations for a most vigorous defence were found to have been made at both places, but the State troops were probably required for the Confederate army. The difficulties arising from the indirectness of the channel and from the shoalness of the bar would have added to the defences by keeping approaching vessels a long time exposed to fire under great disadvantages. Having turned the property over to the military power the expedition was ready for further movements.

A principal and ultimate object of this entire expedition was, in its first conception, to take and keep under control the whole line of seacoast, especially of the State of Georgia. Having heard at Fernandina that the works at Brunswick in Georgia had been abandoned, Com. Dupont on the 7th of March despatched a force, consisting of the Mohican, Pocahontas, and Potomska, under Commander Gordon, to hold the place. It is a port of entry in the extreme southeastern part of the State of Georgia, pleasantly situated on Turtle river, and has a spacious harbor. It is the eastern terminus of the Brunswick and Florida railroad. Commander Gordon with his vessels crossed the bar on the 8th, and anchored at sundown within two miles of the forts commanding the channel. The next day he took possession of the batteries on St. Simon's Island, and on Jeky Island. When abandoned, all their guns and ammunition had been removed. The town also was entirely deserted, and nearly all the property which could be removed had been taken away. Proclamations were posted by Commander Gordon on several public buildings, urging the inhabitants to return to their homes and promising protection to the property of all good citizens. The force then retired to the vessels.

On the 18th with the Potomska and Pocahontas Commander Gordon proceeded from St. Simon's Sound through the inland passage to Darien on the Altamaha river. Piles had been driven in two places across the passage, which were removed. Darien like Brunswick was entirely deserted, and also all the plantations on St. Simon's Island. But one white man was found on the island, and one old negro, although about fifteen hundred troops had been quartered there a few months previous. The former appeared to be in great dread of the coming of the Union force, and had been told that they would destroy even women and children.

At the same time when this force was order-

ed to Brunswick on the 7th of March, Com. Dupont sent the gunboats Ottawa, Seneca, Pam-bina, and Huron, with the Isaac Smith and Ellen under Lieut. Stevens to St. John's river with instructions to cross its difficult and shallow bar, feel the forts if still held, and push on to Jacksonville and even Pilatka and capture river steamers. St. John's river empties into the Atlantic some twenty-five miles south of Fernandina. On the 11th Lieut. Stevens succeeded in crossing the bar and anchored for the night. During the evening large fires were seen in the direction of Jacksonville, which proved to have been made under the order of the Confederate commander, Gen. Trapier, by the burning of mills, houses, and property belonging to Northern men suspected of entertaining Union sympathies. On arriving at Jacksonville during the next day, the corporate authorities came off to Lieut. Stevens and gave up the town. The 4th New Hampshire, Col. Whipple, was landed and took possession. The location of the town is on the northern bank of the St. John's, about twenty-five miles from its mouth. It contains about three thousand inhabitants. From almost all the houses a white flag was displayed on the approach of the force, and men, women, and children of all colors turned out to see the display. A Union feeling was aroused and encouraged. A public meeting was called and resolutions adopted in favor of organizing a Union State Government and calling a convention to meet at Jacksonville for that purpose on the 10th of April, then approaching. On the 8th of April the Union commander, Gen. Wright, evacuated the town, and then sent information of his movement to the Confederate commander, Gen. Trapier, inviting him to come and re-occupy the town, and requesting him to take care of the women and children remaining. On the 9th the Confederate officers stood on the dock and watched the vessels sailing away. On the 10th, the Union convention, which had been warmly encouraged by these retiring officers with their force, was called to assemble. Of course it was not held. The more active Unionists had through fear left with the fleet.

Com. Dupont, immediately after having despatched Commander Gordon to Brunswick and Lieut. Stevens to Jacksonville, as above stated, proceeded himself toward St. Augustine. Arriving off the harbor he ordered Commander Rodgers to approach the city with a flag of truce, presuming that if there were any people along the coast likely to remain in their houses, they would be found at St. Augustine. As Commander Rodgers approached the city, a white flag was hoisted upon one of the bastions of Fort Marion. As he landed upon the wharf and inquired for the chief authority, he was soon joined by the mayor and conducted to the city hall, where the municipal authorities were assembled. His report to Com. Dupont proceeds as follows:

I informed them that, having come to restore the

authority of the United States, you had deemed it more proper to send in an unarmed boat to inform the citizens of your determination, than to occupy the town at once by force of arms; that you were desirous to calm all apprehensions of harsh treatment, and that you should carefully respect the persons and property of all citizens who submitted to the authority of the United States; that you had a single purpose to restore the state of affairs which existed before the rebellion.

I informed the municipal authorities that so long as they respected the authority of the Government we serve, and acted in good faith, municipal affairs would be left in their own hands, so far as might be consistent with the exigencies of the times. The mayor and council informed me that the place had been evacuated the preceding night by two companies of Florida troops, and that they gladly received the assurances I gave them, and placed the city in my hands.

I recommended them to hoist the flag of the Union at once, and in prompt accordance with the advice, by order of the mayor, the national ensign was displayed from the flag staff of the fort. The mayor proposed to turn over to me the five cannon mounted at the fort, which are in good condition and not spiked, and also the few munitions of war left by the retreating enemy. I desired him to take charge of them for the present, to make careful inventories and establish a patrol and guard, informing him that he would be held responsible for the place until our force should enter the harbor.

I called on the clergymen of the city, requesting them to re-assure the people, and to confide in our kind intentions toward them. About 1,500 people remain in St. Augustine, about one-fifth of the inhabitants having fled. I believe there are many citizens who are earnestly attached to the Union, a large number who are silently opposed to it, and a still larger number who care very little about the matter. There is much violent and pestilent feeling among the women; they have a theatrical desire to figure as heroines! Their minds have doubtless been filled with the falsehoods so industriously circulated in regard to the lust and hatred of our troops.

On the night before our arrival a party of women assembled in front of the barracks and cut down the flag staff, in order that it might not be used to support the old flag. The men seemed anxious to conciliate in every way. There is a great scarcity of provisions in the place. There seems to be no money, except the wretched paper currency of the rebellion, and much poverty exists.

In the water battery at the fort are three fine army 32-pounders and two 8-inch sea coast howitzers, with shot and some powder. Several good guns were taken away some months ago. The garrison of the place left from St. Augustine at midnight on the 18th, for Smyrna, where are said to be about 800 troops, a battery, the steamer Carolina, and a considerable quantity of arms and ammunition.

The fort at this place is the second one of the old forts in Florida of which possession had then been recovered. The other is Fort Clinch at Fernandina. St. Augustine is farther south than Jacksonville and situated on the north shore of Matanzas Sound about two miles from the sea, from which it is separated by the island of Anastasia. The population exceeds two thousand.

The next object of Com. Dupont was to visit Musquito Inlet, fifty miles farther south. It had been reported to him that the inlet was resorted to by vessels of light draft for the introduction of arms transhipped from English vessels and steamers at the English colony of Nassau. Accordingly the Penguin, Lieut. T. A. Budd, and the Henry, Andrew S. W. Mather,

master, were sent in advance and ordered to cross the bar and establish an inside blockade and guard from incendiarism the live oak timber on the Government lands. On their arrival they started with four or five light boats and forty-three men and moved southward into Mosquito lagoon, but when returning, they were unexpectedly fired on, upon landing, and the commanding officers and three men were killed, and several wounded, and two taken prisoners.

By these operations along the Florida coast some small steamers and other vessels were captured, and the blockade was rendered more effective by the actual occupation of the principal ports. The country appeared to be undefended and entirely unprepared to make any resistance against the overwhelming Union force. Many fortified positions were found, but the soldiers were not seen. The white population in Florida in 1860 was 77,778, and during the previous year the State sent about ten thousand men to the Confederate army. Her military strength was thus reduced to a feeble condition. Whatever progress was made in restoring the Union was defeated by the sudden evacuation of Jacksonville and the abandonment of many Union citizens there. It taught the people of the State that so long as the Confederate Government existed in security, it might at any time return and demand their allegiance.

Commodore Dupont now returned to Port Royal, leaving a small force at all the points taken. On his arrival on the 27th of March, he learned that the formidable Confederate batteries on Skidaway and Green islands had been abandoned, by which complete control was obtained of Warsaw and Ossibaw sounds and the mouths of Vernon and Wilmington rivers, which form a part of the approaches from the south to Savannah.

Toward Charleston the only movement of importance which had been made by Gen. Sherman was the occupation of Edisto Island by the 47th New York. This took place on the 11th of February. This island is about twelve miles long and nine broad, and is about ten miles from the mainland, twenty miles from the Charleston and Savannah railroad, and forty miles from Charleston. The island was found to be entirely deserted except by the negroes. Considerable cotton was gathered, although the greater portion of that produced had been burned.

On the 31st of March Maj.-Gen. David Hunter assumed the command of the department of the South, consisting of the States of South Carolina, Georgia, and Florida. Thus Gen. Sherman was relieved of the command and assigned to another post. In a proclamation issued on the same day, Gen. Hunter announced the division of his department into three districts as follows:

1. The first, to be called the Northern District, will comprise the States of South Carolina, Georgia, and

all that part of Florida north and east of a line extending from Cape Canaveral northwest to the Gulf coast, just north of Cedar Keys and its dependencies, and thence north to the Georgia line. The headquarters of this district will be at Port Royal, South Carolina, and Brig.-Gen. H. W. Benham (who will relieve Brig.-Gen. Sherman) is appointed to command this district and the troops therein, which troops will constitute a division, to be called the First Division of the Department of the South.

2. The second, to be called the Southern District, will comprise all of Florida and the islands adjacent, south of the said line from Cape Canaveral, extending northwest to the Gulf coast, just north of Cedar Keys. The headquarters of this district and the troops will remain, as at present, under command of Brig.-Gen. J. M. Brannan.

3. The third, to be called the Western District, will comprise that part of Florida west of the line before described as running north from Cedar Keys to the Georgia line. The headquarters of this district will remain at Fort Pickens, as at present, with Brig.-Gen. L. G. Arnold commanding.

The preparations, commenced by Gen. Sherman for the capture of Fort Pulaski, were pushed forward by Gen. Hunter, until the fort surrendered in April, as has been above described. The subsequent movements under Gen. Hunter consisted in reconnoissances in force toward Charleston. The southern boundary of the harbor of Charleston is formed by James Island. This island is bounded on the north by the harbor of Charleston and the Ashley river, on the northwest by Wappoo Creek, on the south and southwest by Stono river, and on the east are a few small islands and the ocean. Wappoo Creek connects with the Ashley river in the immediate rear of Charleston, and by entering Stono river and into Wappoo Creek, gunboats can reach Charleston. The next island south of importance is John's Island, and the next Edisto Island. Between these and Hilton Head is a number of islands of much less size. Early in May Com. Dupont ordered the channel of Stono river to be sounded out and buoys to be placed. This was completed on the 20th of May, and the gunboats Unadilla, Pembina, and Ottawa crossed the bar and entered the river. Along the river, owing to its great importance as a means of access to the city, a vast number of earth-work fortifications had been erected. All of

these were abandoned as the gunboats proceeded. The distance from the mouth of the Stono to Wappoo Creek is about eight miles. Little was done in the river by the fleet for many days, except silencing some of the Confederate batteries, and preventing the erection of others in commanding points likely to be needed on the march toward Charleston, of which this was designed as a preliminary movement. No signs of the approaching army appeared for two weeks, during which several reconnoissances were made by the fleet. The fire of the forts at the entrance to Wappoo Creek was drawn from two large rifled cannon at the lower battery of seven guns. The Huron and Pembina were anchored within range of these guns and within three miles of Charleston. From their masts could be seen a dozen spires, cupolas and observatories, the top masts of two or three large ships, and nearly all the northwestern part of the city. On the 2d of June the military advance with Gens. Hunter and Benham arrived and were landed on James Island, to await the coming of Gen. Wright with cavalry, artillery, and additional infantry from the Edisto. An important fortification which had been vacated was occupied on James Island. On the 5th the additional forces arrived, and a series of skirmishes ensued for the next ten days both on James and John's islands. On the 13th a sharp contest occurred between several New York and Pennsylvania regiments and the 47th Georgia.

Meanwhile a diversion was made by a small Confederate force against Hilton Head, which caused much consternation there, but effected nothing further.

It was soon manifest that the Confederate force had been increased, and nothing of importance could be further effected by Gen. Hunter without reinforcements. As the Government had none at this time to send, not being able to reinforce the more important army in Virginia, military operations were comparatively suspended.

Up to this time movements of some importance had taken place in Missouri and Arkansas. Two sharp skirmishes for the numbers engaged took place,—the one at Mt. Zion, eighteen miles southwest of Sturgeon, on the 28th of December, 1861, and the other near Fayette, on the 8th of January of the year 1862. In the former, Brig.-Gen. Prentiss commanded, and in the latter Major Torneru. They produced no special influence on the campaign in that department. On the 29th of January, Gen. Earl Van Dorn took command of the Confederate forces in the trans-Mississippi district, which comprised a considerable portion of the State of Missouri, with his headquarters at Little Rock. On the preceding day, the division of the Union army under the command of Col. Jeff. C. Davis left Marseilles for Springfield. It consisted of four regiments—the 8th



and 22d Indiana, 37th Illinois, and 9th Missouri, with two batteries, and three companies of cavalry. The other forces immediately moved forward, and combined under Gen. Curtis. On the 11th of February this army moved forward from Lebanon, formed in three divisions—the right under Col. Davis, the centre under Gen. Sigel, and the left under Col. Carr. Six miles from Springfield on the 12th, a skirmish took place between the advance of this force and a body of Confederate troops, with serious loss to both sides. During the night a continuous fire was kept up between the pickets. On the next morning the Confederate force had retreated, and Gen. Curtis occupied Springfield without opposition. About six hundred sick and a large amount of stores were left behind by the Confederate General Price. Gen. Halleck, in command of this department, sent the following despatch to the commander-in-chief, Gen. McClellan, at Washington:

St. Louis, February 14, 1862.

The flag of the Union floats over the court house in Springfield. The enemy retreated after a short engagement, leaving a large amount of stores and equipments, which were captured by Gen. Curtis. Our cavalry are in close pursuit.

H. W. HALLECK, Major-General.

Such had been Gen. Halleck's skilful management of this department, that a few days previous he had received the following despatch from the Secretary of War:

WASHINGTON, February 8, 1862.

*Maj.-Gen. Halleck, St. Louis:* Your energy and ability received the strongest commendation of this Department. You have my perfect confidence, and you may rely upon my utmost support in your undertakings. The pressure of my engagements has prevented me from writing you, but I will do so fully in a day or two.

EDWIN M. STANTON, Secretary of War.

As Gen. Price retreated Gen. Curtis followed rapidly in pursuit. On the 16th his army had advanced sixty-nine miles south of Springfield, and on the 18th had crossed the Arkansas line. Several skirmishes took place in the mountain defiles. The following despatch was sent to Washington by Gen. Halleck:

St. Louis, February 18, 1862.

*To Maj.-Gen. McClellan, Washington:*

The flag of the Union is floating in Arkansas. Gen. Curtis has driven Price from Missouri, and is several miles across the Arkansas line, cutting up Price's rear, and hourly capturing prisoners and stores. The army of the Southwest is doing its duty nobly.

H. W. HALLECK, Major-General.

On the 19th Gen. Price had been reënforced by Gen. McCulloch, and made a stand at Sugar Creek crossing, but was defeated after a short engagement, and retreated. Squads of recruits from Missouri, on their way to join the Confederate force, were captured at this time, among whom was Brig.-Gen. Edward Price, son of Gen. Price. On the 26th Gen. Price had been driven from his stronghold at Cross Hollows, leaving his sick and wounded, and such stores as he could not destroy. He burned his

extensive barracks at that place. The Federal forces had now, for some days, been subsisting chiefly on provisions which they had captured.

On the 27th, Gen. Halleck sent the following despatch to Washington:

HEADQUARTERS, St. Louis, February 27.

*Maj.-Gen. McClellan:*

Gen. Curtis has taken possession of Fayetteville, Arkansas, capturing a large number of prisoners, stores, baggage, &c.

The enemy burnt a part of the town before they left. They have crossed the Boston Mountains in great confusion. We are now in possession of all their strongholds.

Forty-two officers and men of the Fifth Missouri cavalry were poisoned at Mud Town by eating poisoned food which the rebels left behind them. The gallant Capt. Dolfort died, and Lieut. Col. Von Dutch and Capt. Lehman have suffered much, but are recovering. The anger of our soldiers is very great, but they have been restrained from retaliating upon the prisoners of war.

H. W. HALLECK, Major-General.

Gen. Price thus reported his retreat from Missouri, under date of Feb. 25:

"About the latter part of January my scouts reported that the enemy were concentrating in force at Rolla, and shortly thereafter they occupied Lebanon. Believing that this movement could be for no other purpose than to attack me, and knowing that my command was inadequate for such successful resistance as the interests of my army and the cause demanded, I appealed to the commanders of the Confederate troops in Arkansas to come to my assistance. This, from correspondence, I was led confidently to expect, and relying upon it, I held my position to the last moment, and, as the sequel proved, almost too long; for on Wednesday, February 12, my pickets were driven in, and reported the enemy advancing upon me in force. No resource was now left me except retreat, without hazarding all with greatly unequal numbers upon the result of one engagement. This I deemed it unwise to do. I commenced retreating at once. I reached Cassville with loss unworthy of mention in any respect. Here the enemy in my rear commenced a series of attacks running through four days. Retreating and fighting all the way to the Cross Hollows in this State, I am rejoiced to say my command, under the most exhausting fatigue, all the time with but little rest for either man or horse, and no sleep, sustained themselves, and came through, repulsing the enemy upon every occasion with great determination and gallantry. My loss does not exceed four to six killed and some fifteen to eighteen wounded."

On the 1st of March, Gen. Curtis issued the following address to the people of the Southwest:

HEADQUARTERS ARMY OF THE SOUTHWEST, }  
CAMP HALLECK, ARK., March 1, 1862. }

I have received a private communication from an intelligent writer, a citizen of Arkansas, who says: "We, as citizens, have left our homes and firesides for the purpose, as we supposed, of having to defend ourselves against a brutal soldiery that would lay waste our humble homes, and outrage the chastity of our wives and daughters, and place our own lives in jeopardy. We

have organized what is called Home Guard Companies, partly of Union men and partly of Southern men, all of whom are anxious to return to their homes. We are happy to find that you and your men are not composed of that class of persons commonly called jayhawkers, who do not regard the rights of citizens and property, but confine the war to its legitimate object."

The falsehoods circulated concerning us have driven thousands from their homes, and I take the liberty of responding publicly to the sentiments expressed by the writer, because these falsehoods have involved the whole community in the troubles which he seeks to mitigate.

The only legitimate object of the war is peace, and the writer only does me justice when he says I adhere to this legitimate object. Peaceable citizens shall be protected as far as possible. I act under strict orders of Maj.-Gen. Halleck. The flight of our foes from their camps, and the imitation of their conduct by the citizens, in fleeing from their homes, leaving their effects abandoned as it were for the victors, have much embarrassed me in my efforts to preserve discipline in my command, as these circumstances offered extraordinary temptations.

The burning of farms and fields of grain in Missouri, and extensive barracks and valuable mills in Arkansas by the enemy, has induced some resentments on the part of my troops, which I have severely punished. Necessary supplies for my command could not keep up with my rapid movements, and peaceable citizens not being at home to sell them to my quartermasters, I am compelled to take them without purchase, making settlement difficult and doubtful; occasioning irregularities which I have always labored to counteract. If peaceably disposed citizens will stay at home, or return home, and check the clandestine, stealthy warfare that is carried on under the cover and cloak of peaceable citizens, much of the havoc of war will be avoided, and many poor families can be protected from distress and misery. I have followed the war-path through the entire State of Missouri, have seen the havoc and devastation surrounding it, and I deplore the prospect of these disasters in the virgin soil of Arkansas.

Armed men, in the garb of citizens, are concealed by citizens, and the unfortunate condition of Missouri will be transferred to Arkansas, if you allow this complicity of yourselves in the struggle. If you do not discriminate by requiring soldiers to wear some distinctive badge, you must not complain if we cannot discriminate.

There is no honor, no glory, no good that can be gained by taking up arms in this way, to defend your homes, for we do not wish to molest them if you are peaceably disposed. We only wish to put down rebellion by making war against those in arms, their aiders and abettors. We come to vindicate the Constitution, to preserve and perpetuate civil and religious liberty, under a flag that was embelmed in the blood of our Revolutionary fathers. Under that flag we have lived in peace and prosperity until the flag of rebellion involved us in the horrors of civil war.

We have restored the Stars and Stripes to north-western Arkansas, where I am glad to find many who rejoice to see the emblem of their former glory, and hope for a restoration of the peace and happiness they have enjoyed under its folds. A surrender to such a flag is only a return to your natural allegiance, and is more honorable than to persist in a rebellion that surrendered to the national power at Forts Henry and Donelson, at Nashville and at Roanoke, and throughout the most powerful Southern States. Why then shall the West be devastated to prolong a struggle which the States of Maryland, Virginia, Kentucky, North Carolina, and Tennessee cannot successfully maintain?

Disband your companies; surrender your arms; for in all instances where men in arms have voluntarily surrendered and taken the oath of allegiance to our common country, they have been discharged. No prisoners have, to my knowledge, been shot or hung, or cruelly treated by us.

I know of no instance where my troops have treated

females with violence, and I have not heard of a complaint of any kind. I enjoin on the troops kindness, protection, and support for women and children. I shall, to the best of my ability, maintain our country's flag in Arkansas, and continue to make relentless war on its foes, but shall rejoice to see the restoration of peace in all the States and Territories of our country—that peace which we formerly enjoyed and earnestly desire; and I implore for each and all of us that ultimate, eternal peace "which the world cannot give or take away." I have the honor to be,

Very respectfully, your obedient servant,

SAMUEL R. CURTIS,

Brig.-Gen. Commanding Army of the Southwest.

On reaching Arkansas the forces of Gen. Price were rapidly reinforced by regiments which had been stationed in Arkansas and the Indian Territory. Knowing this fact, Gen. Curtis expected an attack would soon be made upon him. He therefore selected Sugar Creek, as the strongest of several strong places taken from the enemy, to make a stand against any and all odds. The position of Gen. Curtis's force on the 6th of March was as follows: The first and second divisions, under Gens. Sigel and Asboth, were four miles southwest of Bentonville under general orders to move round to Sugar Creek about fourteen miles east. The third division, under Col. Jeff. C. Davis, had moved to take position at Sugar Creek, under orders to make some preparatory arrangements and examinations for a stand against the enemy. The fourth division was at Cross Hollows under command of Col. E. A. Carr, about twelve miles from Sugar Creek on the main telegraph road from Springfield to Fayetteville. The number of his force is stated by Gen. Curtis to have been not more than 10,500 cavalry and infantry with forty-nine pieces of artillery. The following were the forces engaged in the battle of Pea Ridge: 1st division, under command of Col. Osterhaus,—86th Illinois, 12th Missouri, 17th Missouri, battalion of 8d, two battalions of Benton Hussars cavalry, one battalion 89th Illinois cavalry, batteries A and B, twelve guns. A brigade, consisting of the 25th and 44th Illinois, was commanded by Col. Coler. Another brigade was commanded by Col. Greusel.

The second division, commanded by Brig.-Gen. Asboth, consisted of the 2d Missouri, Col. Schæfer; 2d Ohio battery, six guns, Lieut. Chapman; 15th Missouri, Col. Joliet; 6th Missouri cavalry, Col. Wright; light battery of six guns, Capt. Elbert; battalion 4th Missouri cavalry, Maj. Messaur. These two divisions were commanded by Gen. Sigel.

The third division, commanded by Brig.-Gen. Jeff. C. Davis, consisted of 2 brigades: the 1st, commanded by Col. Barton, was composed of the 8th, 18th and 22d Indiana, and an Indiana battery of six guns. The 2d brigade, commanded by Col. White, was composed of the 37th Illinois, 9th Missouri, 1st Missouri cavalry, and a battery of four guns.

The fourth division, commanded by Col. Carr, consisted of 2 brigades; the 1st, commanded by Col. Dodge, was composed of the 4th Iowa, 35th

Illinois, and an Iowa battery. The 2d brigade, commanded by Col. Vandever, consisted of the 9th Iowa, 25th Missouri, 3d Illinois cavalry, and a battery. There were also two battalions of the Iowa 3d cavalry and a mountain howitzer battery of four guns. A considerable number of sick soldiers belonging to many of these regiments had been left at Rolla and Lebanon.

On the 5th of March, a cold, blustering day, snow having fallen so as to cover the ground, as Gen. Curtis was engaged in writing, not apprehending an immediate attack, he was informed by scouts and fugitive citizens that the enemy were rapidly approaching to give battle. His cavalry would be at Elm Springs, twelve miles distant, that night, and his infantry had then passed Fayetteville. Couriers were immediately sent to Gen. Sigel and Col. Carr to move with their divisions to Sugar Creek.

The Confederate forces were under the command of Gen. Van Dorn, who had arrived at their camp on the 2d of March. They were stated to be composed of between twenty-five and thirty thousand men, as follows: Missouri troops under Brig.-Gen. Price; Arkansas, Louisiana, and Texas troops under Brig.-Gen. McCulloch; Choctaw, Cherokee, and Chickasaw Indians under Brig.-Gen. Pike.

Gen. Sigel, upon receiving the orders of Gen. Curtis to march to Sugar Creek, and becoming aware of the dangerous position of his command, immediately ordered Col. Schaefer to break up his camp, and send the cavalry company to Osage Springs to cover his right flank and to march with his regiment to Bentonville. All the other troops he ordered to be prepared to march at two o'clock on the next morning. Commencing his march in the morning, he reached Bentonville, and, retaining a small force to set as a rear guard, he sent his train forward. At ten o'clock it was reported that large masses of troops, consisting of infantry and cavalry, were moving from all sides toward the front and both flanks of the rear guard at Bentonville. By a mistake a part of this force designed to act as rear guard had gone forward, leaving about six hundred men with five pieces of the light battery. These troops were ordered by Gen. Sigel to march in the following order: two companies of the 12th Missouri regiment at the head of the column deployed on the right and left as skirmishers, followed by the light battery; one company of the same regiment on the right and one on the left of the pieces, marching by the flank, and prepared to fire by ranks to the right and left, the remainder of the regiment being behind the pieces; two companies of cavalry to support the infantry on the right and left, and the rest of the cavalry with one piece of artillery following in the rear. Thus the troops advanced slowly in this formation, modified from time to time according to circumstances, fighting and repelling the enemy in front, on the flanks, and rear, whenever he stood or attacked, for five hours and a half, when re-

enforcements from Gen. Curtis arrived. What made this march a more difficult achievement, was the condition of the roads, which were in many places very narrow and badly cut up. This movement brought Gen. Sigel's division to the west end of Pea Ridge, where he formed a junction with Gen. Davis and Col. Carr.

On this day Gen. Curtis had been engaged in diligently preparing earthwork defences and cutting timber to check the progress of the enemy along the Fayetteville road, where they were confidently expected by him. But during the day and the ensuing night Gen. Van Dorn moved his entire army around the west side of Gen. Curtis's army, so that Gen. Price occupied the Fayetteville road north of Gen. Curtis's camp, while Gens. McCulloch and McIntosh lay north of Gen. Sigel. Thus the Confederate forces fronted south, and the division under Gen. Price formed their left wing. The distance apart of the main bodies of the two wings of each army was nearly three miles, thus forming in fact four distinct armies. Gens. Van Dorn and Price were opposed to Gen. Curtis, who had with him Gen. Davis and Cols. Carr and Asboth, leaving one division to Gen. Sigel opposed to Gens. McCulloch and McIntosh. Gen. Curtis was thus compelled to make a change of front, and formed it almost two miles further north and resting on the brow of a range of hills fronting north, called Pea Ridge. In this position the enemy occupied the line of retreat for Gen. Curtis, if defeated. The battle commenced on the 7th on the right of Gen. Curtis's column, and raged furiously during the entire day. The brunt of it was borne by Col. Carr's division. The Confederate forces, owing to their superior numbers, the numerous and deep ravines and the thick brush which covered the hills, succeeded in driving the Union right from the ground occupied in the morning, with a severe loss on both sides. They encamped on the battle ground during the night, and the right wing of Gen. Curtis fell back nearly a mile. The field occupied by this portion of both armies during the day did not exceed three fourths of a mile in diameter.

On the left wing Gen. McCulloch commenced in the morning by moving his force to the south and east, evidently intending to form a junction with Gens. Van Dorn and Price. Gen. Sigel, perceiving this movement and the effect it would have toward surrounding the Federal force, sent forward three pieces of light artillery, with a supporting force of cavalry, to take a commanding position and delay the movement of the enemy until the infantry could be brought into proper position for an attack. Hardly had the artillery obtained their position and opened fire, when an overwhelming force of the enemy's cavalry came down upon them, scattering the cavalry and capturing the artillery. This terrible onslaught of the enemy allowed their infantry to reach unmolested the cover of a dense wood. On the west of this

wood was a large open field. Here and in the surrounding wood a protracted struggle ensued between Gen. McCulloch and the forces of Col. Osterhaus. But the arrival of Gen. Davis's force, as a reinforcement, so strengthened Gen. Sigel that the enemy were finally routed and driven in all directions. At the same time Gens. McCulloch and McIntosh and a number of the Confederate officers were killed.

Thus the right wing of Gen. Curtis was defeated, and his left was victorious. The discipline of the right wing, however, was such as to keep the troops completely together, while the right wing of the enemy, which was defeated, was greatly disorganized in consequence of their loss of officers and lack of discipline. During the night all the Confederate forces formed a junction on the ground held by their left wing, which was a strong position, and they felt confident of a complete victory on the next day. On the Federal side the prospect was gloomy. The night was too cold to sleep without fires, and their position and nearness to the enemy would not allow fires along the advance lines. The men were exhausted by two days' fighting and the loss of sleep. The enemy's forces, in far superior numbers, held the only road for their retreat, and nearly a thousand of their companions were dead or wounded. No alternative was presented to them but to conquer or be destroyed.

With the rising sun the battle commenced. Col. Carr's division had been reinforced by a large part of that of Gen. Davis, thus enabling the right barely to hold its position. Gen. Sigel began to form his line of battle by changing his front so as to face the right flank of the enemy's position. For this purpose he first ordered the 25th Illinois, Col. Coler, to take a position along a fence in open view of the enemy's batteries, which at once opened fire upon the regiment. He next ordered a battery of six guns, partly rifled twelve-pounders, into a line one hundred paces in the rear of the 25th infantry, on a rise of ground. The 15th Missouri then formed into a line with the 25th Illinois on their left, and another battery of guns was similarly disposed a short distance behind them. Thus more infantry with batteries in their rear was placed until about thirty pieces of artillery, each about fifteen or twenty paces from the other, were in continuous line, the infantry in front lying down. Each piece opened fire as it came in position, and the fire was so directed as to silence battery after battery of the enemy.

For two hours the Confederate forces stood unshaken before that fire, with their crowded ranks decimated and their horses shot at their guns. One by one their pieces ceased to reply. Then onward crept the infantry and onward came the guns of Gen. Sigel. The range became shorter and shorter. No charge of the enemy could face those batteries or venture on that compact line of bayonets. They turned and fled. Again the Union line was advanced with a partial change of front, when an order to

charge the enemy in the woods was given. Then the infantry rising up pressed forward into the dense brush, where they were met by a terrible volley, which was fiercely returned; volley followed volley, still the line pushed forward until more open ground was obtained, when the Confederate force broke in confusion. As Gen. Sigel advanced, Gen. Curtis also ordered the centre and right wing forward. The right wing turned the left of the enemy and cross-fired into his centre. This placed him in the arc of a circle. The charge was then ordered throughout the whole line, which utterly routed their forces as above stated, and compelled them to retire in complete confusion, but rather safely through the deep and almost impassable defiles of Cross Timbers. Gen. Sigel followed toward Keetsville, and the cavalry continued the pursuit still further. The Union loss in this battle was 212 killed, 926 wounded, and 124 missing. The Confederate killed and wounded was larger in numbers, with a loss of nearly 1000 prisoners. Among their killed were Gens. McCulloch and McIntosh.

On the 9th Gen. Van Dorn, under a flag of truce, requested permission to bury his dead, which was readily granted. In the reply to this request Gen. Curtis said: "The General regrets that we find on the battle-field, contrary to civilized warfare, many of the Federal dead, who were tomahawked, scalped, and their bodies shamefully mangled, and expresses the hope that this important struggle may not degenerate to a savage warfare."

To this statement, Gen. Van Dorn replied: "He hopes you have been misinformed with regard to this matter, the Indians who formed part of his forces having for many years been regarded as civilized people. He will, however, most cordially unite with you in repressing the horrors of this unnatural war; and that you may cooperate with him to this end more effectually, he desires me to inform you that many of our men who surrendered themselves prisoners of war, were reported to him as having been murdered in cold blood by their captors, who were alleged to be Germans. The general commanding feels sure that you will do your part, as he will, in preventing such atrocities in future, and that the perpetrators of them will be brought to justice, whether German or Choctaw."

Gen. Curtis in answer further said: "I may say, the Germans charge the same against your soldiers. I enclose a copy of a letter from Gen. Sigel, addressed to me before the receipt of yours, in which the subject is referred to. As 'dead men tell no tales,' it is not easy to see how these charges may be proven, and the General hopes they are mere 'camp stories,' having little or no foundation. The Germans in the army have taken and turned over many prisoners, and the General has not before heard murder charged against them; on the contrary, they have seemed peculiarly anxious to exhibit



the number of their captured as evidence of their valor. Any act of cruelty to prisoners, or those offering to deliver themselves as such, on the part of the soldiers of this army, coming to the knowledge of the General commanding, will be punished with the extreme penalty of the law.<sup>13</sup>

The following is Gen. Halleck's despatch to Washington, announcing this battle:

ST. LOUIS, March 10, 1862.

*To Maj.-Gen. McClellan:*

The army of the Southwest, under Gen. Curtis, after three days' hard fighting near Sugar Creek, Arkansas, has gained a most glorious victory over the combined forces of Van Dorn, McCulloch, Price, and McIntosh. Our killed and wounded are estimated at one thousand. That of the enemy still larger. Guns, flags, provisions, &c., captured in large quantities. Our cavalry is in pursuit of the flying enemy.

H. W. HALLECK, Major-General.

The Confederate force retired south of the Boston Mountains unpursued by Gen. Curtis, to obtain reinforcements and to recover from their loss. Meantime reinforcements were sent to Gen. Curtis from Kansas and Missouri. He fell back to Keetsville, and remained through the month. On the 5th of April, it being supposed that Gen. Price was moving on Springfield, Missouri, Gen. Curtis began a march in that direction. On that day he advanced eighteen miles and on the next twenty, to the junction of Flat Rock with James river. Failing in an attempt to cross the James, the force moved to Galena, where a crossing was effected in a rain storm. On the next day, the 9th, Bear Creek, thirteen miles, was reached, and on the 10th Forsyth, eighteen miles, where the army was concentrated. The high water of the river delayed active operations. Gen. Price, with a body of mounted men, was encamped about five miles south and on the other side of the river. On the 16th of April an expedition was sent out under Col. McCrellis to destroy some saltpetre works located eight miles below the Little North Fork, south side of White river. It was entirely successful. About ten thousand pounds nearly prepared for transportation were destroyed. The army next moved to West Plains, eighty-seven miles, thence to Salem, Arkansas, which is southeast of Forsyth, Mo., and distant one hundred and seventeen miles. Thence it advanced to Batesville, crossed the White river, and took the route to Little Rock, the capital of the State. It advanced to Searcy, fifty miles from Little Rock, where an order was received from Gen. Halleck to send ten regiments by a forced march to Cape Girardeau and thence to Corinth. The army then fell back to Batesville, which is the capital of Independence county and the most important town in the northeastern part of the State. It is situated on the White river about four hundred miles from its mouth. The river is navigable to this point for small steamers. Such was the scarcity of supplies that the army suffered severely. An expedition was fitted out in June from Memphis to descend the Mis-

issippi to the mouth of Arkansas and thence up the White river to Batesville. (See page 66.) It was unsuccessful. Supplies were subsequently sent by land from Missouri, which reached Gen. Curtis about the 1st of July. His position during this period was critical, and excited much apprehension, as he was known to be nearly destitute of provisions, far distant from the sources of supply, and surrounded in the midst of a wilderness by foes. From Batesville he now advanced to Jacksonport at the confluence of the White and Black rivers, thence passing through Augusta and Clarendon he reached Helena on the Mississippi river, one hundred and seventy-five miles from Batesville.

It was reported soon after that Confederate troops under Gen. Price were crossing the Mississippi at a point between Napoleon and Vicksburg, and Gen. Curtis started with a body of troops on transports to make an exploration. The steam ferry boat at Napoleon, upon the approach of Gen. Curtis, was withdrawn up the Arkansas river, whither he followed and captured it with fifteen other ferry and flat boats. A large number of boats were destroyed on the Arkansas by this expedition, which soon after returned to Helena. Gen. Curtis was then absent until the close of September, when he was appointed to command the department of Missouri, containing the States of Missouri and Arkansas and the adjacent Indian Territory, with his headquarters at St. Louis. Helena continued to be occupied by the Federal troops, but active military operations were suspended. This closed the campaign of Gen. Curtis.

After the departure of Gen. Curtis from Helena on the 15th of November, an expedition under Gen. Alvin P. Hovey, consisting of eight thousand infantry and cavalry, started for the White river; but in consequence of new bars which had formed, and the low stage of the water, it entirely failed of the object intended, and returned. The command of the post was then taken by Gen. Steele, who had arrived with a division of troops. Subsequently Gen. Hovey was sent upon an expedition from Helena into Mississippi to cooperate with Gen. Grant on his advance into that State. The particulars of this expedition are stated in connection with the campaign of Gen. Grant.

The subsequent military operations in Arkansas exerted no special influence on the conduct of the war. They may be briefly stated in this place. The Confederate forces in the State, in October, were estimated to consist of five thousand men under Gen. Hindman, posted five miles north of Little Rock; five thousand men under Gen. Roan, posted fifty miles southeast of Little Rock at White Sulphur Springs, near Pine Bluff on the Arkansas river; at Cross Hollows in the northwestern part of the State, between four and five thousand men, chiefly conscripts under Gen. Rains; Gen. Holmes, in chief command, was at Little Rock with two thousand men; Gen. McBride was at Bates-

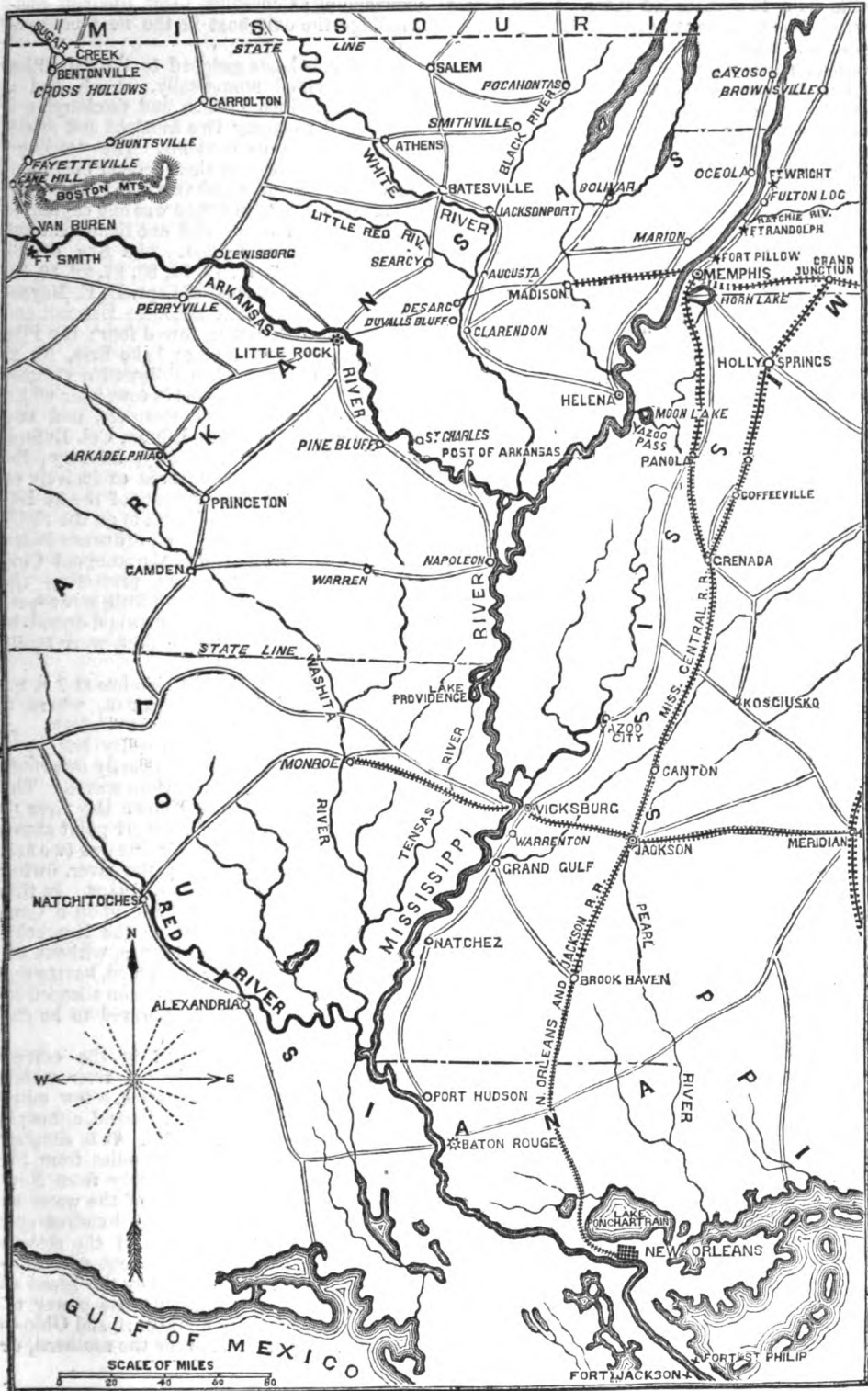

ville with two thousand more. Small forces were also at Arkansas, Crystal Hill, and Arkadelphia. The latter post had been made the seat of government. These forces were estimated at twenty thousand men with a deficient outfit. In the northwestern part of Arkansas, near Cross Hollows, twelve miles south of Fayetteville, Gen. Herron had a severe conflict with a Confederate force near the end of October. Again on the 28th of November Gen. Blunt made an attack on Gen. Marmaduke with about eight thousand men, at Cane Hill, forty-five miles north of Van Buren, which caused the Confederate force to retreat to Van Buren. Again, on the 7th of December, the combined Confederate forces under the command of Gen. Hindman, estimated at fifteen thousand men, made an attempt to cut off reinforcements for Gen. Blunt, ten miles south of Fayetteville. The Confederate forces advanced on the flank of Gen. Blunt's position, and attacked Gen. Herron with the reinforcements, who held them in check until they were attacked in the rear by Gen. Blunt at Crawford's Prairie. The fight continued obstinate until dark, when the Confederate forces retreated across Boston Mountains. The loss was severe on both sides, and the advance of the Confederate troops into Missouri was checked.

The campaign in the West was now pushed through. The evacuation of Columbus, and the flanking of other Confederate positions on the Mississippi river by the force on the advance up the Tennessee river, led to the fitting out of an expedition to move down the Mississippi. On the 4th of March an armed reconnoissance, commanded by Flag Officer Foote and General Cullum, was made as far as Columbus. This consisted of six gunboats, four mortar boats, and three transports having on board two regiments and two battalions of infantry under Gen. Sherman. On arriving at Columbus, it was found to have been evacuated and subsequently occupied by two hundred and fifty of the 2d Illinois on a scouting expedition. The Confederate troops had chiefly retired down the river to Island No. 10 and New Madrid. The evacuation was a consequence of the position being flanked on both sides of the river. The distances to various points down the river are as follows: Cairo to Columbus, 20 miles; Hickman, 37; Island No. 10, 45; New Madrid, 55; Point Pleasant, 87; Plumb Point, 154; Island No. 88, 164; Fort Wright, 167; Fulton Landing, 168; Hatche River, 170; Island No. 84, 170; Fort Randolph, 175; Fort Pillow, 238; Memphis, 242;

This force returned to Cairo, and on the 14th a formidable expedition left to move down the river. The following vessels formed the fleet: flag ship Benton, Lieut. Phelps acting flag captain; gunboats Cincinnati, Commander R. N. Stembel; Carondelet, Commander Walke; Mound City, Commander Kelly; Louisville, Commander Dove; Pittsburgh, Lieut. Thompson commanding; St. Louis, Lieut. Paulding

commanding; Conestoga, Lieut. Blodgett commanding—the only boat in the fleet not iron-clad.

The mortar boats assigned to the expedition were designated numerically. Each had a mortar of 18-inch calibre and discharging a round shell weighing two hundred and fifteen pounds without its contents. The "sailing" or "running" crews of these mortar boats consisted of one captain and two men. The force to fire the mortars in action was one captain to each brace of mortars, and one lieutenant and twelve men to each boat. The Nos. of the vessels were, 5, 7, 11, 19, 22, 23, 27, 29, 30, 38, under command in chief of Capt. H. E. Maynardier, U. S. Army. The steamers Hammit and Wilson, lashed together, towed four; the Pike and Wisconsin four others; Lake Erie, No. 2, towed two others. Then followed a steamer with a barge laden with coal in tow, after which came the two ordnance steamers, and two transports with the 27th Illinois, Col. Buford, and 15th Wisconsin, Col. Hey, infantry—the latter regiment being composed exclusively of Norwegians—and also a battery of the 2d Illinois artillery. With the gunboats on the right, followed by the mortar fleet, ordnance boats, and transports with troops, the gunboat Conestoga brought up the rear, protecting the transports, while eight or ten little screw propellers, used for conveying orders and despatches from the flag ship to the fleet, were busily darting in all directions.

The expedition reached Columbus at 1 P. M., and at 3 o'clock left for Hickman, where it arrived between five and six o'clock. A small force of Confederate cavalry left upon its approach. The town was partly deserted; a few Union flags, however, were waved. The next morning it proceeded down the river to within half a mile of the Missouri point above Island No. 10, which by an air line was two and a half miles distant, while by the river, owing to the bend, it was four miles distant. In this position the flagship opened fire upon a Confederate battery discovered on the Kentucky shore, but, owing to the distance, without effect. Two of the mortar boats then, having got into position, opened upon and soon silenced it. A large Confederate force appeared to be encamped on that side.

Island No. 10 is situated in the corner of that bend of the Mississippi river which touches the border of Tennessee, a few miles further up the river than New Madrid, although nearly southwest of that point. It is situated about two hundred and forty miles from St. Louis, and nine hundred and fifty from New Orleans. The average depth of the water at this point is from ninety to one hundred and twenty feet, and the breadth of the stream from mainland to mainland about nine hundred yards. The current runs by the island at a moderately fast rate, and with the power of three rivers—Mississippi, Missouri, and Ohio—combined. The island is near the southern, or

what might be termed the eastern bank of the river, but at this point the stream varies from its southern course and turns abruptly to the northwest, leaving this island in the southern angle of the bend. It is about forty-five miles, by the course of the river, south of Columbus, and about twenty-six miles from Hickman. It is near Obionville, which is in Obion county, in the northwest extremity of Tennessee, where it borders on Kentucky and Missouri. The Mississippi river passes to the north and to the south of Obionville, leaving a land distance between the two waters very inconsiderable, and easily walked across in less than an hour, although the voyage by water between the same points, owing to the bends in the river, is about twenty miles. The surface of the surrounding country is nearly level. Obionville is connected by a turnpike road with Columbus, in Kentucky, via Hickman, and with Troy, the capital of the county.

The fortifications on the island and mainland adjacent consisted of eleven earthworks, with seventy heavy cannon, varying in caliber from thirty-two to one hundred pounders, rifled. The bombardment commenced on the 16th of March, and continued with more or less vigor until the 7th of April. A different plan, however, was arranged for the capture of the island. This consisted in cutting a canal across a portion of the narrow and low peninsula, by which the transports could pass below the island, and a part of the troops with Gen. Pope at New Madrid be taken across the river, and thus completely invest the island.

On the 21st of February, by orders of Gen. Halleck, Gen. Pope proceeded to Commerce in Missouri above Cairo, and was followed by a force numbering in the aggregate about forty thousand men. With this army Gen. Pope proceeded southwardly in the early part of the last week in February, destined for New Madrid. In a direct line the distance from Commerce to New Madrid is about fifty miles, but by the road it is between sixty and seventy-five miles. On the 3d of March he arrived with his forces before New Madrid, and found the place occupied by five regiments of infantry and several companies of artillery. The defensive works consisted of one bastioned earthwork, mounting fourteen heavy guns, about half a mile below the town, and another irregular work at the upper end of the town, mounting seven pieces of heavy artillery, together with lines of intrenchment between them; six gunboats, carrying from four to eight heavy guns each, were anchored along the shore between the upper and lower redoubts. The country being perfectly level and the river so high that the guns of the boats looked directly over the banks, Gen. Pope found the approaches to the town commanded for miles by guns of heavy caliber.

His first step was to occupy Point Pleasant, twelve miles below, in such a manner that his force could not be driven out by the Confed-

erate gunboats, and thus blockade the river from below. He next procured siege guns from Cairo, which arrived on the 12th of March, and were placed in battery during the night within eight hundred yards of the enemy's main work, so as to command that and the river above it. The battery consisted of two small redoubts connected by a curtain, and mounting four heavy guns, with rifle pits in front and on the flanks for two regiments of infantry. As soon as day dawned on the 13th, these batteries opened fire, and were replied to by the whole of the enemy's heavy artillery on land and water. In a few hours several of the gunboats were disabled, and three of the heavy guns dismounted in the enemy's main work. The cannonading continued all day without producing any impression on the position of Gen. Pope, other than the disabling of one gun by a round shot. The effect of the contest during the day convinced the Confederate commander that he could not hold the town, although he had previously received reinforcements of men and guns from Island No. 10. Accordingly in the night, during a violent storm of rain, he evacuated the town by crossing over to the Kentucky shore. This evacuation was made with considerable precipitation. Almost everything was left behind. Even the pickets were abandoned. "Thirty-three pieces of artillery, magazines full of fixed ammunition, several thousand stand of small arms, hundreds of boxes of musket cartridges, tents for an army of ten thousand men, horses, mules, wagons, &c., were among the spoils."

The Confederate fleet was commanded by Com. Hollins, and their land force by Gens. McCown, Stewart, and Gantt. The Union loss was fifty-one killed and wounded; the Confederate loss was estimated by Gen. Pope to be larger. A number of their dead were left unburied. By the possession of these works Gen. Pope commanded the river, so as to cut off all communication with Island No. 10 from below. It was on the day after this evacuation that the fleet left Cairo.

In order to cut off entirely the retreat of the Confederate force from Island No. 10, it was necessary that a portion of Gen. Pope's army should be taken across the Mississippi to the Tennessee shore. To bring down transports a channel was made, twelve miles long, six of which were through heavy timber. The trees standing in water, had to be cut off four feet below its surface. While this work was pushed forward the bombardment of the island was continued. On the night of the 1st of April, under the cover of darkness and storm, a boat expedition from the fleet, with a small force under the command of Col. Roberts of the 42d Illinois, landed at the upper or No. 1 Fort on the Kentucky shore and spiked the six guns mounted, and retired without injury. The pickets of the enemy fired and fled, and the troops in the vicinity also retreated. As the work on the canal approached

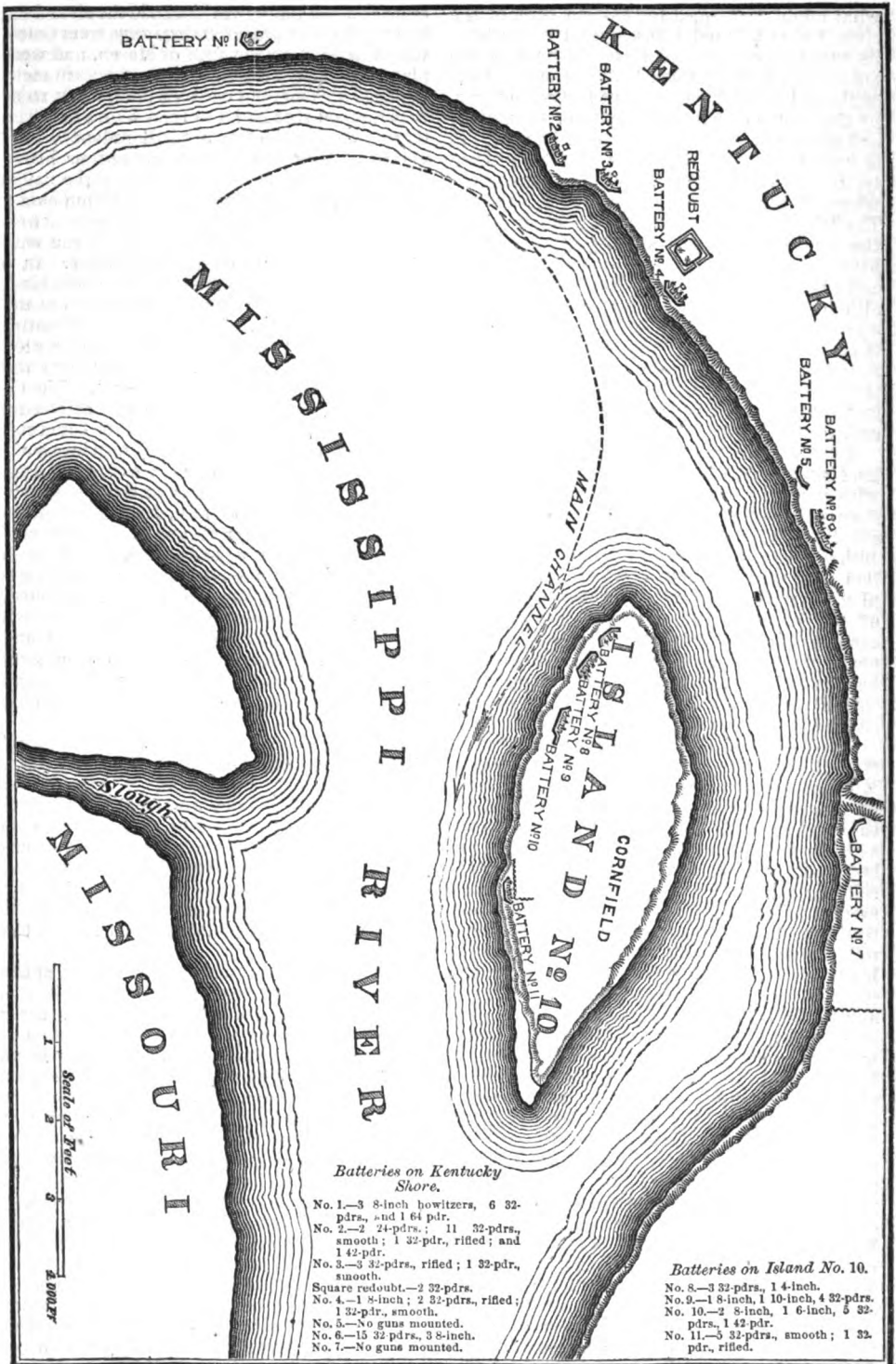

completion, it was evident that the assistance of the gunboats would also be required to make a successful landing of the troops across the river. The enemy, to oppose any attempt that might be made to cross the river, had planted field pieces along the left bank for the distance of several miles above and below New Madrid. Gunboats were also needed to protect the transports from any gunboat of the enemy that might appear during the passage across the river. For these reasons the gunboat *Carondelet*, Capt. Walke, undertook to run down past the batteries of the island on the night of the 4th of April. For this purpose her hull was protected in all weak places by additional covering, and a barge laden above with hay was taken in tow on her left side. Starting at ten o'clock on the night of the 4th, amid the darkness of an impending storm, she proceeded on in silence. Twice as she approached the batteries of the enemy the soot in the chimneys caught fire, and a flame five feet high leaped out from their tops, lighting brightly the upper deck of the vessel, and everything around. It was seen by the enemy, and the anxious listeners for the signal of her safety in the fleet above now heard the long roll beat in the camps on the island. At the same time five rockets were sent up from the mainland and the island, and were followed by a cannon shot from Fort No. 2. A full head of steam was now let on, to make the greatest possible speed; and while vivid flashes of lightning lit up the hurried preparations of the enemy, while peal after peal of thunder reverberated along the river, and the rain fell in torrents, the moment for coolness and heroism came. For thirty minutes the discharge of cannon and musket ball at the dark and silent object, revealed on the waters only by the lightning flash, was furious, but no injury was done. Then stopping her machinery, her officers fired the signal guns to inform their companions in the fleet that she was safe. On the night of the 6th, the gunboat *Pittsburg*, Lieut. Thompson, also passed the batteries. On the morning of the 7th the transports were brought into the river from the bayou where they had been kept concealed, and while the division of Col. Paine was embarking, the gunboats ran down the river and silenced the enemy's batteries at the place of landing. Then the passage of the wide and swift river commenced, and was completed at the hour of midnight.

As soon as the troops began to cross the river the enemy began to evacuate the island and his batteries along the Kentucky shore. The divisions were pushed forward as fast as they landed, that of Col. Paine leading. The Confederate force was driven before him, says Gen. Pope; and although it made several attempts to form in line of battle and make a stand, Col. Paine did not once deploy his columns. It was pushed all night vigorously until, at four o'clock A. M., it was driven back on the swamps and forced to surrender. "Three generals, seven

colonels, seven regiments, several battalions of infantry, five companies of artillery, over one hundred heavy siege guns, twenty-four pieces of field artillery, an immense quantity of ammunition and supplies, several thousand stand of small arms, a great number of tents, horses, and wagons were taken." The force that surrendered was under the command of Gen. Mackall. Before abandoning Island No. 10, the Confederate officers sunk the gunboat *Grampus* and six transports. The force surrendered consisted of Tennessee, Arkansas, Mississippi, Alabama, and Louisiana regiments, and numbered about five thousand. At the island a large amount of commissary stores was found with the tents and baggage of the enemy. Besides there were eleven earthworks, with seventy heavy cannon varying in caliber from 32 to 100-pounders, rifled. The works, erected with the highest engineering skill, possessed great strength. There appeared to be no concert of action between the force on the island and that on the shore. Gen. Pope did not lose a man or meet with an accident in crossing the river or afterward. The canal was made on the suggestion of Gen. Schuyler Hamilton. A part of the distance the route was through a bayou. The cut made was about four miles, sufficient for steamboats of moderate size, and about one thousand trees, ranging from six inches to three feet in diameter, were sawed off about four feet under water by means of long saws worked by hand. When the canal was finished, the water came through with such a current that the boats had to be dropped by lines nearly the whole distance. The work was done by an engineer regiment, under the superintendence of Col. Bissell.

The position thus taken was regarded by the Confederate officers as one of the highest importance to the new line of defence proposed by them. Upon their ability to hold it depended the safety of Memphis, and of the entire Mississippi valley thereabout. This line was adopted by the Confederate commander, with his left resting on the Mississippi, his centre between Jackson, Tenn., and Corinth, Miss., and his right between Florence and Decatur.

On the 12th of April the gunboats under Com. Foote, with the mortar boats, followed by the transports, left New Madrid, and stood down the river. The order of a line of battle was observed. A part of Gen. Stanley's division, and those of Gens. Hamilton and Palmer, were on the transports. Their destination was Fort Pillow or Wright, which is situated on the first Chickasaw Bluffs, near Islands Nos. 83 and 84, and about seventy miles above Memphis. At Plum Point the Mississippi makes a sharp bend, running for some distance eastwardly, and at the first Chickasaw Bluffs turns off abruptly south-southwest, which course it continues below Island No. 84, where it again bends; the convex side of the curve being to the Tennessee shore. Here are the second Chickasaw Bluffs, surmounted by Fort Randolph, some twelve

miles below Fort Pillow. The location of these fortifications was admirably adapted for defence, and in case of a determined stand it would have been very difficult to reduce them. Opposite Plum Point is the village of Osceola in Arkansas.

On the next day, at evening, the fleet arrived at Plum Point and anchored. A force of three Confederate gunboats were in sight most of the time during that day, but kept at a safe distance. The anchorage was about three and a half miles from the fort. Operations against the fort were commenced by moving the mortars to the Arkansas shore at Craighead Point, and opening upon the enemy's gunboats and batteries with shells. The distance of the contending forces across the point was three fourths of a mile, although by the river around the point it was three miles. In the afternoon of the 17th of April fire was opened from the mortars, and rapidly and accurately answered by the fort. This continued until midnight and then ceased; daily afterward it was repeated without any expectation of an immediate reduction of the fort. The high water of the river prevented coöperation of the land forces. On the 4th of May a battle occurred between the gunboats and a Confederate ram and gunboats, which has been thus related:

"The enemy appeared with four boats—three gunboats and a ram—the latter a powerful contrivance, combining immense weight and strength with high speed and admirable steering facilities. Her hull and boilers, as well as all the Confederate rams, were those of old New Orleans towboats. The upper works of these were cut away; their sides protected, in some instances with a layer of railroad iron, and in others only with bales of tightly compressed cotton, hooped and bound together, one to the other, with iron bands. Their bows were pointed and sharp, and apparently of solid iron.

"At their first appearance the gunboats manifested no disposition to come up the river, but sent the ram ahead to attack and destroy the Cincinnati, thinking then, doubtless, to run up and make an easy prey of the defenceless mortar boats. The commander of the Cincinnati perceived the movement and apprehended its intent. The ram was already halfway up to her before she was cut loose, and then the accumulated driftwood on her bows prevented her getting her head out into the stream. To back out would be to run directly upon the enemy while they were seeking to run into her, thus adding to the force of the blow with which they would strike her. In this dilemma she let fly her stern guns full into the face of the enemy, and at the same time attempted to crowd along up the shore, hoping, before moving far, to succeed in getting her head out. Her guns made not the slightest apparent impression upon the ram, which still held its course and was rapidly coming upon the entangled gunboat.

"Again the stern guns were let go full into the face of the enemy, but still her progress was not retarded in the slightest. A moment more and her tremendous weight came with terrible force upon the starboard stern quarter of the gunboat, but without inflicting any serious damage. The force of the blow, however, threw the stern of the vessel in and enabled her to get headway from the shore. Then, in turning out, her broadside was discharged directly into the Confederate craft, which was backing off preparatory to renewing the assault.

"Again the gunboat prepares to open fire on her assailant, and the ram seeks an opportunity to renew the assault. The Cincinnati has worked herself away from the shore and is now more easily handled. Turning to and fro, she gives her antagonist broadside for broadside, with no apparent result. Still he comes on. As he nears his object, his steam apparatus is got ready, and his crew, armed with small arms, prepare to board the Federal craft. Commander Stembel, seeing these demonstrations, orders out carbines, boarding pikes, and cutlasses, and also puts his steam battery in readiness to give the enemy a warm reception. On they come, closer and closer, and strike! The boats collide with fearful violence, followed by the crashing of timbers, and the bending of iron, and the shouts of men, and the discharge of musketry, and, above all, another broadside directly into the enemy now immediately alongside. Amid this general uproar Commander Stembel rushes upon deck, and, seizing a pistol, with admirable aim discharged its contents into the head of the Confederate pilot, killing him instantly. The pilot's mate seized a gun in retaliation, and shot the gallant commander, just as he was turning to give his attention to some other duty, the ball entering high up on his shoulder behind, and, passing in at an upward direction through his neck, went out under his chin. He fell instantly, and was carried below.

"While this fierce engagement was in progress, the shots from the other vessels had exploded the boiler on one of the Confederate gunboats, and set fire to another which was burned to the water's edge.

"The Cincinnati, thus released from her antagonist, sought others of the foe. It was soon after this withdrawal that the Mallory, which is also fitted as a ram, though carrying a heavy armament, moved up and singled out the crippled Cincinnati as her special victim. This craft was more lumbering and slower than the rams proper, and could not be so easily moved about. She worked very hard to get her nose into the Cincinnati's side, but every time was foiled by the movements of the latter. At last she had apparently secured the desired opportunity, and was crowding all steam to make good headway, when an unlooked-for adversary appeared. The St. Louis bore down upon her, unseen, until close on her, and then came

the unavoidable collision—the ram was cut half into and sunk immediately. Her crew perished with her, but half a dozen or so escaping by clinging to the St. Louis. This was a brilliant manœuvre on the part of the St. Louis, relieving and probably saving the Cincinnati, which was already half sunk and almost unmanageable from the weight of water in her hold. Seeing her condition, the acting flag officer signalled her to withdraw, and she was run upon the shoal at the foot of the island, and sunk to the bottom.

“The action had now lasted about forty-five minutes. One of the enemy’s boats had been sunk and two blown up. The rest of their fleet was crippled. To prolong the fight was to insure its destruction. They therefore gradually fell back, under cover of the smoke, around the point to the protection of their land batteries. The Cincinnati was the only boat injured in the Union fleet. Four were wounded on board of her.”

On the night of the 4th of June Fort Pillow was evacuated. Everything of value was either destroyed or removed by the Confederate officers. On the same night Fort Randolph, some miles below, was evacuated. The few guns were dismantled. Com. Ellet, in his report to the Secretary of War, said: “Randolph, like Pillow, is weak, and could not have held out long against a vigorous attack.” The remark is worthy of notice, as it raises an inquiry why such an attack was not made. The forts were not attacked because this expedition, was not sustained at the critical time for its success. There were no land forces to cooperate with the fleet.

On the 18th of April the gunboats and transports arrived before Fort Pillow, and on the 4th of June this fort and the one below were evacuated, and the way clear for the fleet to attack Memphis. On the 7th of April the battle of Pittsburg Landing took place between the Federal forces, under Gen. Grant, and the Confederate forces, under Gen. Beauregard, which resulted in the withdrawal, by Gen. Beauregard, of all his forces from the battle field to the strong position at Corinth. Reinforcements were required by the Federal army, and Gen. Pope was ordered to join it. On the 31st of April he arrived in transports up the Tennessee river at Pittsburg Landing. His force numbered between twenty and twenty-five thousand men, and were taken on some thirty transports. This withdrawal of the force of Gen. Pope put a stop to the progress of the Mississippi river expedition. The gunboats, however, were obliged to remain in such force as to prevent any movement of the Confederate gunboats up the river. Soon after the withdrawal of Gen. Pope, Com. Foote obtained leave of absence, and the command of the fleet was taken by Charles Ellet, jr., until the arrival of Charles H. Davis, the successor of Com. Foote.

As has been stated, Forts Pillow and Ran-

dolph were evacuated on the night of the 4th of June. This evacuation was in consequence of the withdrawal of a large portion of the Confederate army from Tennessee, and their abandonment of Corinth. The positions of Fort Pillow, Randolph, and Memphis could not be held under these circumstances, and were therefore wisely evacuated.

Nothing now remained to oppose the Federal fleet but the Confederate gunboats. On the 5th of June the fleet arrived within two miles of Memphis, and came to anchor for the night. On the 6th, at 4½ o’clock in the morning, the gunboats Benton, Cairo, Carondelet, Louisville, and St. Louis, and the four rams Monarch, Lancaster, No. 3, and Queen of the West, weighed anchor, and dropped slowly down toward the city. The Confederate gunboats were seen approaching in order of battle. This was in two lines, the first consisting of the Beaugard, Little Rebel, Gen. Price, and Gen. Bragg, the second of the Gen. Lovell, Gen. Van Dorn, Jeff. Thompson, and the Sumter. When within three fourths of a mile, a shot from the Little Rebel, the flag ship, fell within a short distance of the Cairo, which replied with a broadside, and soon the engagement became general. The Confederates had fewer guns than their opponents, but exceeded them in the number of gunboats. The scene of the battle was in front of the city of Memphis, and the shores were crowded with spectators. After half an hour two of the rams, Monarch and Queen of the West, which had been lying on the Arkansas side, in rear of the line of battle, steamed out toward the scene of action. The Queen of the West started directly for the Beaugard, and that gunboat fired at, but missed her. A second shot struck the ram but did her no injury, and she steamed steadily and swiftly toward her adversary. When she was within ten feet the latter swung round, and the ram missed her prey. Not discouraged, however, the Queen ran toward the Gen. Price, which fired several shots but did no damage, and thrust her iron prow into the wheelhouse of the Price, crushing it to pieces, and causing the vessel to leak so badly that she was run to the Arkansas shore, to prevent her from sinking. The Beaugard now determined to avenge the Price, and hurried toward the Queen, while the ram in full motion was dashing toward her foe. They bore down upon each other bravely, but the skilful pilot of the enemy contrived to evade the shock of the Queen, and struck her aft so heavily that the ram was disabled and began to leak. The Monarch, seeing the state of affairs, dashed boldly at the Beaugard. The latter fired four times at the ram, and struck her bulwarks once, the ball glancing harmlessly. She could not, however, avoid the unerring aim of the Monarch, which crashed through her bow, and caused her to fill in a few minutes and go down as far as her cabin, the shallowness of the water preventing her sinking lower, and the white flag she had run up



stopping further damage from the fleet. The *Monarch* then looked after her disabled consort, the *Queen of the West*, and towed her ashore, placing her in a position of security. The gunboats now increased their fire against the enemy, when the flag ship, having obtained an excellent range, threw a 50-pound ball from a rifled Parrott, striking the *Gen. Lovell* aft above the water line, tearing a great hole in her, through which the water rushed like a torrent. She began to sink at once, giving few of the officers and crew time to save themselves. In less than four minutes the vessel had sunk in seventy-five feet of water, and passed entirely out of sight. Some of the crew went down with the *Lovell*, but about fifty of them leaped into the river, and were struggling in the water, when the *Benton's* crew arrived in advance of several other cutters from the flotilla, and just in time to see the chimneys of the hostile gunboat disappear beneath the water. Many of the crew had already begun to swim for the shore. Some six or seven, however, were rescued by the cutter, but the current was so strong that a large number were carried off and drowned. The engagement still continued warm and desperate. The smoke of the battle so obscured the boats that it was difficult to see them at any distance, yet the levee of Memphis was black with the crowd of human beings. From the time the rams made their appearance, the Confederate gunboats had been steadily falling back, though continuing to fire heavily, before the advance of the Federal gunboats.

The *Jeff. Thompson*, *Gen. Bragg*, *Sumter*, and *Van Dorn* were the only vessels remaining, and these were so frequently struck and saw so little opportunity of escaping, that they turned their bows ashore. As soon as the *Thompson* reached the shore her officers and crew leaped off, and ran through the woods; but a shell exploding on the vessel, she took fire and was burned to the water's edge. The *Gen. Bragg* reached the shore about half a mile below the *Thompson*, and her officers and crew escaped. The *Sumter* followed next, and the *Gen. Van Dorn*, which was a swift vessel, alone escaped down the river. The Federal fleet now came to anchor before the city. The engagement had lasted over an hour. No one was killed on the fleet. The loss of the other side could not be stated. About one hundred were made prisoners. The other mortar boats, owing to a misconception of orders, were not engaged.

The following correspondence then ensued between Com. Davis and the city authorities:

UNITED STATES FLAG STRAKER BENTON, }  
OFF MEMPHIS, June 5, 1862. }

SIR: I have respectfully to request that you will surrender the city of Memphis to the authority of the United States, which I have the honor to represent.

I am, Mr. Mayor, with high respect,

C. H. DAVIS, Flag Officer commanding, etc.

To His Honor the Mayor of the City of Memphis.

The answer of the mayor was as follows:

MAYOR'S OFFICE, MEMPHIS, June 6, 1862.

SIR: Your note of this date is received, and contents noted. In reply I have only to say that, as the civil authorities have no means of defence, by the force of circumstances the city is in your hands.

Respectfully, JOHN PARK, Mayor.  
To C. H. DAVIS, Flag Officer commanding, etc.

Commander Davis wrote in reply as follows:

UNITED STATES FLAG STRAKER BENTON, }  
OFF MEMPHIS, June 6, 1862. }

SIR: The undersigned, commanding the naval military forces of the United States in front of Memphis, has the honor to say to the Mayor and the city that Col. Fitch, commanding the Indiana brigade, will take military possession immediately.

Col. Fitch will be happy to receive the cooperation of His Honor the Mayor and the city authorities in maintaining peace and order. To this end he will be pleased to confer with His Honor the Mayor at the military headquarters at 3 o'clock this afternoon.

Yours, etc., C. H. DAVIS,

Flag Officer commanding, etc.

To the Mayor of the City of Memphis.

The military occupation of the city followed, and the appointment of a provost marshal. Memphis is the most populous and important town, on the Mississippi river, between St. Louis and New Orleans. Its population in 1860 was 22,625.

About the 10th of June the gunboats *St. Louis*, *Mound City*, *Lexington*, and *Conestoga*, with the transport *New National*, having on board the 46th Indiana regiment, Col. Fitch, left Memphis, on an expedition up the White river, to open communication with the army of Gen. Curtis, and to remove the obstructions in that river. The White river is formed by the junction of three small branches, which unite a few miles east of Fayetteville, Arkansas. It flows first northwesterly into Missouri, and after making a circuit of about one hundred miles, returns into Arkansas, and pursues a southeasterly course to the mouth of Black river. Thence its direction is nearly south, until it enters the Arkansas fifteen miles above its mouth. It is navigable by steamboats to the mouth of Black river, three hundred and fifty miles, in all stages of water.

As the expedition approached St. Charles, the *Mound City*, being in advance, was fired on from two concealed batteries. This was returned. Meantime the troops were landed below for the purpose of marching in the rear and capturing the batteries. At this juncture a ball from a siege gun on the bluff struck the forward and left side of the *Mound City* and penetrated the casemate and passed through the steam drum. The vessel was immediately filled with the escaping vapor and nearly every one on board was scalded; only twenty-three of the officers and crew, numbering one hundred and seventy-five, escaped uninjured. A horrible scene ensued. Many of the crew, frantic with pain, jumped overboard, and some were drowned. The boats from the *Conestoga*, which was coming up at the time, were sent to their relief, but the enemy fired on the men in the water with grape and canister from their field pieces, killing most of those who were

attempting to escape. Meantime Col. Fitch, learning the facts, pushed forward with his regiment and carried the works at the point of the bayonet. They consisted of two batteries, the lower of which mounted six field pieces, and the upper one three heavy siege guns. About thirty prisoners were taken, among whom was Col. Frye, commanding the post. This expedition failed to open communication with Gen. Curtis, as has been heretofore stated.

The military operations in Tennessee, which finally controlled the movements of the Mississippi river expedition, had paused after the capture of Nashville, as above described, but were soon resumed again. The first step consisted in fitting out a great expedition to proceed under Gen. Grant up the Tennessee river. More than fifty-seven steamers and two gunboats were required to transport and convoy the force. It was organized in five divisions, each consisting of infantry, cavalry, and artillery. The advance was under the command of Gen. Sherman, 2d division under Gen. Hurlbut, 3d division under Gen. McClelland, 4th division under Gen. L. Wallace, 5th division under Col. Lanman of the 7th Iowa regiment. On the 11th of March the transports began to arrive at Savannah in Tennessee. On the night of the 12th the Tyler and Lexington were sent up the river to reconnoitre as far as Eastport, forty miles above Savannah. The enemy was found constructing fortifications and with a considerable force. It was known that the Confederate forces were also concentrated along the lines of railroad south and southwest of the river.

The line of defence now adopted by the Confederate commander after his first line was broken up, had for its base the Charleston and Memphis railroad, the preservation of which was absolutely necessary to any pretence of resistance through northern Mississippi, Alabama, and Georgia. Along this railroad are Tusculumbia and Florence at the foot of the Muscle shoals in the Tennessee river and the junction with the Florence and Nashville railroad; Decatur near the head of the lower Muscle shoal; Huntsville and Bellefontaine; Stevenson, important as the junction with the railroad from Nashville through Murfreesboro' and Chattanooga, a strong position. All these points are east of Corinth. On the west of Corinth the railroad runs in a nearly straight line to Memphis, ninety-three miles distant; and northwest runs the road to Jackson, almost in the centre of west Tennessee.\*

The Union line was the Tennessee river, extending from Paducah, Kentucky, to Eastport in Mississippi. The gunboats Lexington and Ty-

ler, by moving up and down the river, prevented the erection of batteries. Above Eastport, at Chickasaw Bluffs and at some other points, Confederate batteries were placed to command the navigation of the river.

On the 5th of March, Gen. Beauregard assumed the command of the Confederate forces in this department, when he issued the following address to his soldiers:

HEADQUARTERS ARMY OF THE MISSISSIPPI,  
JACKSON, TENN., March 5. }

SOLDIERS: I assume this day the command of the army of the Mississippi, for the defence of our homesteads and liberties, and to resist the subjugation, spoliation, and dishonor of our people. Our mothers and wives, our sisters and children, expect us to do our duty, even to the sacrifice of our lives.

Our losses since the commencement of this war, in killed, wounded, and prisoners, are now about the same as those of the enemy.

He must be made to atone for the reverses we have lately experienced. Those reverses, far from disheartening, must nerve us to new deeds of valor and patriotism, and should inspire us with an unconquerable determination to drive back our invaders.

Should any one in this army be unequal to the task before us, let him transfer his arms and equipments at once to braver, firmer hands, and return to his home.

Our cause is as just and sacred as ever animated men to take up arms; and if we are true to it and to ourselves, with the continued protection of the Almighty we must and shall triumph.

G. T. BEAUREGARD,

General Commanding.

Associated with Gen. Beauregard in command were Gens. Albert Sidney Johnston, Bragg, Polk, Pillow, Cheatham, and others. The Confederate force consisted not only of the troops from the adjacent States which had been in service for months, but also of new levies now called out by the governors on the requisition of President Davis. They were encamped principally at Corinth, with detachments at various points on the railroad, so situated that they could be easily concentrated on any point.

Corinth is at the intersection of the Mobile and Ohio and Memphis and Charleston railroads, in Tishemingo county, Mississippi, forty miles from Grand Junction, fifty-eight miles from Jackson, Tennessee, and about eighteen miles from Pittsburg on the Tennessee river. It is situated in a hilly, semi-mountainous country.

The Federal forces at first concentrated at Savannah, a small town of two hundred inhabitants, on the Tennessee river, about one hundred and seventy miles above Fort Henry. The number of transports which arrived by the 18th of March, was eighty-two. This force comprised all of Gen. Grant's original command, with an additional force of infantry, almost entirely from the State of Ohio. All the steamers that formed the regular line of packets between Louisville and New Orleans and between Louisville and St. Louis, were in the fleet, carrying from 1200 to 1500 men each, and heavily laden. The demonstrations of the inhabitants along the shore of the river were of the most extravagant character. One declared

\* The distances of these places along the line of the Memphis and Charleston railroad are as follows: From Memphis to Germantown, 15 miles; to Collierville, 24; Lafayette, 31; Moscow, 39; La Grange, 49; Grand Junction, 52; Saultsbury, 58; Middleton, 69; Pocahtons, 75; Corinth, 93; Burns, 107; Inka, 115; Tusculumbia, 145; Jonesboro, 168; Decatur, 188; Huntsville, 212; Bellefonte, 259; Stevenson, 273; Chattanooga, 309.

it to be "the second coming of Christ." The command of the army was taken by Gen. Grant soon after its arrival at Savannah, and it was advanced seven miles to Pittsburg Landing. Savannah was made a depot for stores, with only a few troops. Here troops and supplies were sent to Gen. Grant by Maj.-Gen. Halleck, both from St. Louis and Cairo. There had also been such a change in the position of the enemy before Gen. Buell at Nashville, that the original plan was altered, and he was directed by Maj.-Gen. Halleck to make a junction of his forces with those under Gen. Grant. By General War Order No. 8 of the President, dated March 11th, the Departments of Kansas and Kentucky, respectively under the command of Gen. Hunter and of Gen. Buell, were united with that of the Missouri, under the designation of the Department of the Mississippi, and of this consolidated Department Gen. Halleck was assigned the command.

It was the original plan of Gen. Buell to advance with his army in several columns upon northern Alabama over the principal roads leading to that region from Nashville. With this object in view, the divisions of Gens. Mitchell, Nelson and McCook left Nashville on the same day, and by different roads. But the Confederates, having retired from Murfreesboro and formed along the new line they proposed to defend, rendered necessary a corresponding change in the plan of Gen. Buell. A direct advance upon Alabama by Gen. Buell's forces would not only have involved an unnecessary amount of labor and slowness of movement, owing to the destruction of bridges over the watercourses, and other impediments, but the passage of the Tennessee into northern Alabama being practicable for a large army at a few places only, the Confederates could by means of the railroad have easily collected a large force to dispute it at any point. This concentration of the main body of the Confederate forces in localities within the contemplated field of the operations of Gen. Grant's army, not only gave to the latter an opportunity to employ the whole of his force to the best possible advantage, but enabled Gen. Halleck to order Gen. Buell to turn his army toward western Tennessee, to cooperate with Gen. Grant and cross the river. Thus combined, they were regarded as certain to be superior to the Confederate army in the number, armament, and fighting trim of their commands.

On the 28th of March, Gen. Buell left Nashville and passed the advance of his divisions at Columbia. On the 28th, 29th, and 30th the divisions of his army had crossed Duck river on a new bridge, and advanced through Columbia, distant eighty-two miles from Savannah.

Meantime most active preparations had been made to assemble a large Confederate force at Corinth, and to fortify that position, which is about eighteen miles south of Pittsburg Land-

ing. The force of Gen. Grant was posted at Pittsburg and along both sides of the river toward Crump's Landing and Savannah, but kept in active service scouring the country. The importance of the approaching contest to the Confederate States could not be concealed. If Corinth fell, Memphis would also fall, and the whole territory of the Gulf States would be open to an army larger than that of the Potomac. The plan adopted by Gens. Johnston and Beauregard was to strike an unexpected blow before the arrival of Gen. Buell's forces. On the 3d of April, Gen. Johnston issued the following address to his soldiers:

HEADQUARTERS ARMY OF MISSISSIPPI, }  
CORINTH, MISS., April 3. }

*Soldiers of the Army of the Mississippi:*

I have put you in motion to offer battle to the invaders of your country, with the resolution and discipline and valor becoming men, fighting, as you are, for all worth living or dying for. You can but march to a decisive victory over agrarian mercenaries sent to subjugate and despoil you of your liberties, property, and honor.

Remember the precious stake involved; remember the dependence of your mothers, your wives, your sisters, and your children on the result. Remember the fair, broad, abounding lands, the happy homes that will be desolated by your defeat. The eyes and hopes of eight million people rest upon you. You are expected to show yourselves worthy of your valor and courage, worthy of the women of the South, whose noble devotion in this war has never been exceeded in any time. With such incentives to brave deeds, and with the trust that God is with us, your general will lead you confidently to the combat, assured of success.

(Signed)

A. S. JOHNSTON,

General Commanding.

The orders accompanying the address divided "the Army of the Mississippi" into three corps. Gen. Beauregard was proclaimed to be in command of the whole force. The first corps was assigned to Gen. Polk, and embraced all the troops of his former command, excepting detached cavalry and artillery, and reserves detached for the defence of Fort Pillow and Madrid Bend. The second corps was assigned to Gen. Bragg, and was to consist of the second division of the army of the Mississippi, less artillery and cavalry "hereafter detached." The third corps was assigned to Gen. Hardee, and consisted of "the Army of Kentucky." To Gen. Crittenden was assigned a command of reserves, consisting of not less than two brigades.

From two to three miles out on the road to Corinth from Pittsburg Landing lay the five divisions of Gen. Grant's army. The advance line was formed by three divisions: Brig.-Gen. Sherman's, Brig.-Gen. Prentiss's, and Maj.-Gen. McClernand's. Between these and the landing lay the two others, Brig.-Gen. Hurlbut's and Maj.-Gen. Smith's, commanded in his absence by Brig.-Gen. W. H. L. Wallace. On the extreme left of the line was one brigade of Gen. Sherman's division, while the other brigades were some two miles distant, forming the extreme right of the advance line. To the left, though rather behind a portion of the line

formed by Sherman's main brigades, lay Gen. McClelland's division, and between it and Gen. Sherman's brigade, on the extreme left, lay Gen. Prentiss's division. No preparations had been made for any means of defence in case of attack, although the position was an exposed one.

The information that Gen. Buell was near at hand, determined Gen. Beauregard to make the attack at once. The movement of his troops from Corinth commenced on the 8d of April. Owing to the difficulties of the roads, they did not reach the vicinity of the Federal forces until Saturday afternoon, the 5th. It was then determined that the attack should be made on the next morning, at the earliest hour practicable, and in three lines of battle: the first and second extending from Owl Creek, on the Confederate left, to Lick Creek on their right—a distance of about three miles—supported by the third and the reserve. The first line consisted of Gen. Hardee's corps, augmented on his right by Gladden's brigade of Bragg's corps, deployed in line of battle, with their respective artillery following immediately, and the cavalry in rear of the wings. The second line followed the first at a distance of five hundred yards, in the same order as the first. The corps under Gen. Polk followed the second line, at the distance of about eight hundred yards, in lines of brigades, deployed with their batteries in rear of each brigade, the left wing supported by cavalry. The reserve followed closely the third line in the same order, its right wing supported by cavalry. These two corps constituted the reserve, and were to support the front lines of battle by being deployed, when required, on the right and left, or otherwise act according to the exigencies of the battle.

At half past five on the morning of April 6, the Confederate lines and columns were in motion. Like an Alpine avalanche they came, attacking first the left of Gen. Grant, under Gen. Prentiss, who, with two thousand of his men, were soon made prisoners. This attack was in part a surprise. Scarcely had the men time to seize their weapons and form, after knowing of the approach of the Confederates. Gen. Grant himself was at Savannah at the commencement, but early reached the raging field. Gradually, as the Confederate line came up, the engagement had become general, and as Gen. Prentiss's division fell back, abandoning their camp, they were supported by Gen. Hurlbut, and thus for a time checked the progress of the Confederates. At the same time the left of Gen. Sherman's division on the right was forced back, and the brunt of the battle, in the centre, fell upon Gen. McClelland's division. Desperate as was their determination, yet at eleven o'clock this division had been pressed back in a line with Gen. Hurlbut. It still did some gallant fighting; once its right swept round and drove the Confederates for a considerable distance, but again fell back, and at the last it brought up near the position of the

camp of Gen. Smith's division, commanded by W. H. L. Wallace. Thus the divisions of Prentiss, Sherman, and McClelland were driven back, their camps were all in the hands of the Confederates, and the whole front line, for which Hurlbut and Wallace were but the reserves, was gone, excepting Stuart's brigade of Sherman's division, on the extreme left. The position of this brigade was along the circuitous road from the Landing to Hamburg, some two miles distant from the former, and near the crossing of Lick Creek. They had remained isolated until after the division of Gen. Prentiss fell back, when the Confederates advanced upon them in such force as to be irresistible in their position, and they fell back a fourth of a mile and made a stand for three fourths of an hour. At this juncture a brigade of Gen. Wallace's reserve, under McArthur, was sent over to their support. They were, however, soon forced to fall back to one ridge, and then to another, and finally at twelve o'clock, badly shattered and disordered, they retreated to the right and rear of McArthur's brigade to reorganize.

Six hours had passed since the approach of the Confederates, and at this time only the divisions of Gens. Hurlbut and Wallace stood between the army and destruction or surrender. Still all was not lost. The divisions of Gens. Hurlbut and Wallace began to make a most gallant stand. The brigade of the latter had been sent to reinforce McArthur's, and thus reunited, filled the space in the line on the left made vacant by the falling back of Gen. Prentiss's division and Stuart's brigade of Gen. Sherman's division, and thus were on the left of Hurlbut's division. By the early breaking of Gen. Prentiss's line, the onset of the Confederates had been made to veer chiefly to the Union left. Here the contest continued stubborn. Four times the Confederates attempted to charge on Gen. Wallace's men. Each time the infantry poured in rapid volleys, and the artillery redoubled their efforts, thus compelling them to retreat with heavy slaughter. Farther to the right, Gen. Hurlbut's division, which had taken an advanced position, was compelled to fall back through its camp to a thick wood behind. Here, with open fields before them, they could rake the approach of the Confederates. Three times their heavy masses bravely charged upon the division, and each time they were repulsed with severe loss. The troops from the driven divisions were reorganized so far as available, and re-sent to the field. Thus the right of Gen. Hurlbut, which was almost wholly unprotected, and the weakness of which does not appear to have been discovered by the Confederates, was in a measure patched out. It had been previously determined that in case of an attack at Pittsburg Landing, the division under Gen. L. Wallace at Crump's Landing, five miles below, should come up on the right and flank the enemy. But no message was sent to this

# MAP OF THE FIELD OF SHILOH

NEAR PITTSBURGH LANDING, TENN.

*Showing the Positions of the U. S. Forces*

UNDER THE COMMAND OF

MAJ. GEN'L U. S. GRANT, U. S. VOL.

AND

MAJ. GEN'L D. C. BUELL, U. S. VOL.

ON THE 6TH. AND 7TH. OF APRIL 1862.

*Surveyed under the direction of*

COL. GEO. THOM, CHIEF OF TOPL ENGRS;

DEPT OF THE MISSISSIPPI.

*Engraved in Relief by E. R. Jewett & Co, Buffalo, N. Y.*

SCALE OF FEET

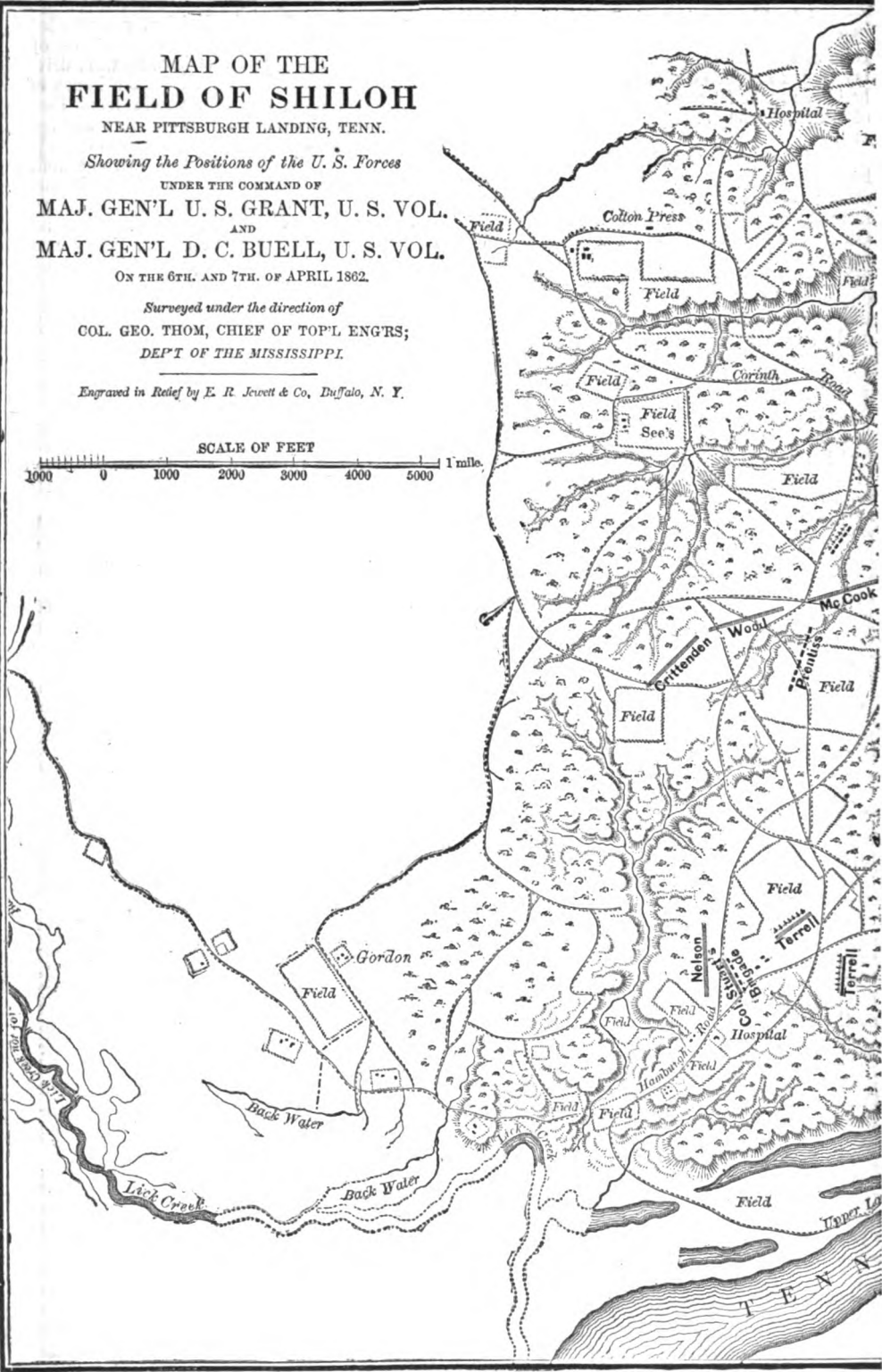
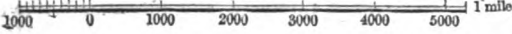

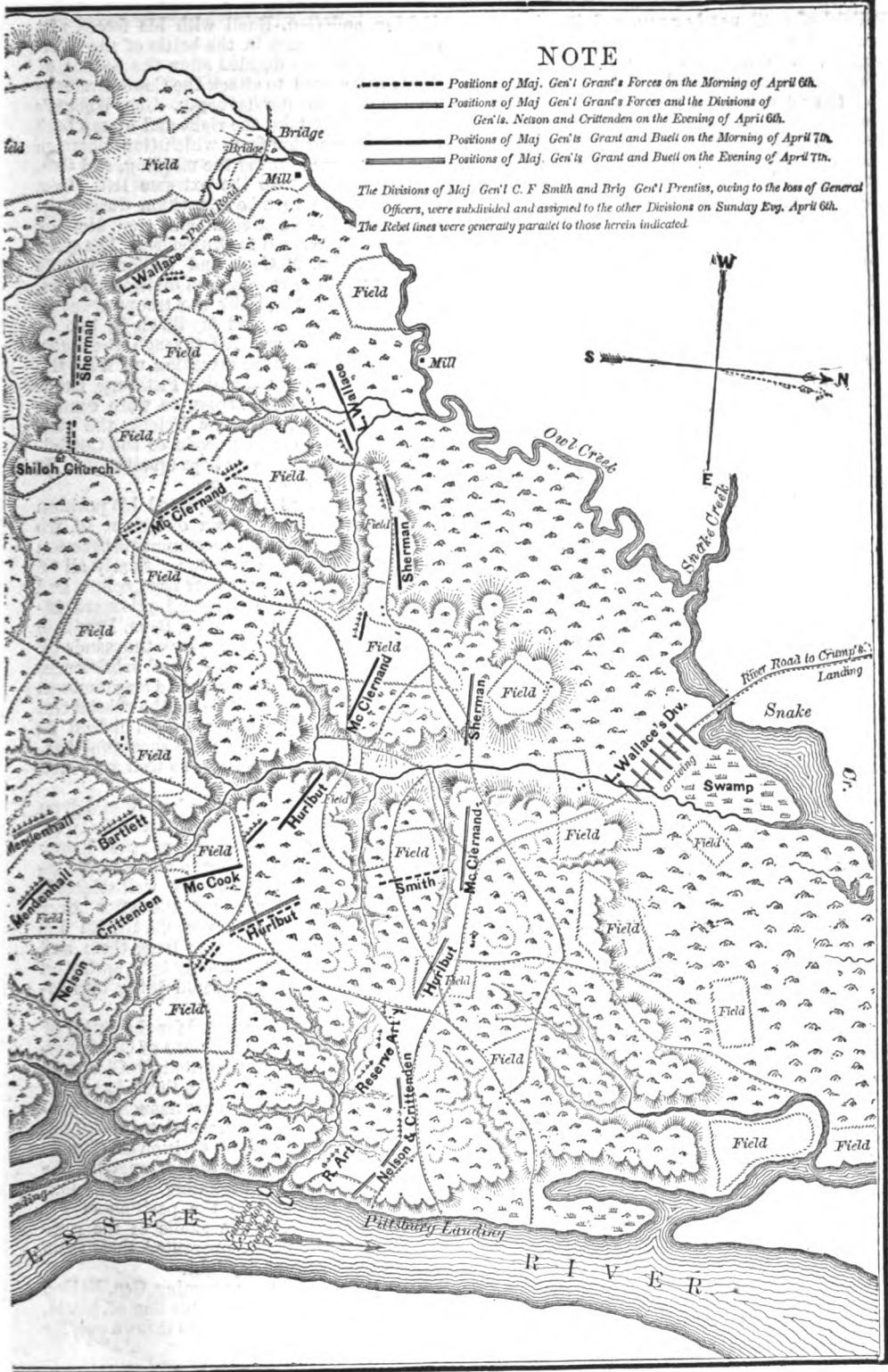

division until nearly noon, and it missed the way on coming up, and did not arrive until night. The division of Gen. Hurlbut at length became exhausted, and fell back out of sight of their camps to a point within half a mile of the Landing. In consequence of losing this support, the division of Gen. Wallace, thus in isolated advance, was compelled to fall back, the last to leave the field. Just at this moment its commander was mortally wounded.

It was now half past four o'clock. The front line of the divisions had been lost since eleven o'clock, and the reserve line was gone too. The Confederates occupied the camps of every division except Smith's, commanded during his sickness by Gen. Wallace, who had just been wounded. The whole army was crowded in the region of Wallace's camp, and to a circuit of one half to two thirds of a mile around the Landing. The next repulse would put it into the river, and there were not transports enough to cross a single division before the enemy would be upon them. Nearly half the field artillery was lost, nearly all the camps and camp equipage. Prisoners had been taken in great numbers.

At this time a lull took place in the firing, the first which had occurred since sunrise. It was thought that the enemy were either preparing for the grand final rush that was to crown the day's success, or that they were puzzled by the last retreat, and were moving cautiously. These few minutes were golden ones for that driven and defeated army, and they were improved. Col. Webster, chief of staff, arranged the guns which he could collect of those that remained, in a sort of semicircle to protect the Union centre and left, upon which it was thought the enemy were now sure to advance. Corps of artillerists to man them were gathered from all the batteries. Twenty-two guns were thus placed in position, two of which were long 32's. In front was a victorious enemy; behind were the remnants of the repulsed divisions of the army driven within half a mile of the Landing, beyond which was a deep and rapid river. Gen. Wallace's division at Crump's Landing had not been heard from. Across the river now was seen the first glitter of the advance of Gen. Buell, but it could not be brought over in time to do much good. Suddenly a broad flash of light leaped out from the darkening woods, and the whistling leaden hail swiftly followed. The enemy were about to make their crowning effort for the day. Instantly the artillery replied, and as they approached nearer, the infantry fired volley after volley. At this time the gunboats, Lexington and Tyler, approached the mouth of Lick Creek, and were able with their guns to reach the field occupied by the Confederates near the river. This was a fire in their flank, which disconcerted their plans. Amid this terrible conflict darkness came on. The enemy had been held at bay.

Meantime Gen. Wallace had arrived with his

division, and Gen. Buell with his forces, part of which took part in the battle of the afternoon, and it was decided after the sounds of battle had ceased, to attack the Confederates as soon as possible after daybreak. Gen. Wallace's division was to take the right and sweep back toward the position from which Gen. Sherman had been driven during the morning, and Gen. Nelson was to take the extreme left. Gen. Crittenden was to take a position during the night next to Gen. Nelson, and Gen. McCook with his division next to Crittenden. The space between Gens. McCook and Wallace was to be filled with the reorganized divisions of Gen. Grant's army. Stealthily the troops crept to their new positions, and lay down in line of battle on their arms. All through the night, Gen. Buell's men were marching up from Savannah to the point opposite Pittsburg Landing, and were ferried across, or were coming up on transports. At nine o'clock, the gunboats commenced a cannonade of the Confederate position, which was kept up all night. It produced little or no effect.

Gen. Beauregard thus reported his position on Sunday night: "At six o'clock P. M., we were in possession of all encampments between Owl and Lick creeks but one. Nearly all of his field artillery, about thirty flags, colors, and standards, over three thousand prisoners, including a division commander (Gen. Prentiss) and several brigade commanders, thousands of small arms, an immense supply of subsistence, forage, and munitions of war, and a large amount of means of transportation—all the substantial fruits of a complete victory—such indeed as rarely have followed the most successful battles; for never was an army so well provided as that of our enemy.

"The remnant of his army had been driven in utter disorder to the immediate vicinity of Pittsburg, under the shelter of the heavy guns of his iron-clad gunboats, and we remained undisputed masters of his well-selected, admirably provided cantonments, after over twelve hours of obstinate conflict with his forces, who had been beaten from them and the contiguous covert, but only by a sustained onset of all the men we could bring into action."

The Federal forces arranged for the battle of the next day were: the divisions of Gens. Nelson, Crittenden, McCook, Hurlbut, McClernand, and Sherman, including in the three latter the shattered and disorganized commands of Prentiss and W. H. L. Wallace, which were without commanders, and the fresh division of Gen. L. Wallace. These divisions were arranged in the order above named, beginning on the left. The change produced in the position of the Confederate forces, by the shells of the gunboats during the night, prevented them from opening the battle at daylight.

At seven o'clock in the morning, Gen. Nelson on the extreme left formed his line of battle, and advanced, with skirmishers thrown out, for

nearly a mile before meeting the enemy in force. They immediately became engaged. There was no straggling, as upon the previous day. Gen. Nelson slowly but steadily advanced, pushing the exhausted enemy before him until half past ten, when under cover of the timber and a furious cannonading they made a general rally. Suddenly the masses of the enemy were hurled with tremendous force against the Federal lines, which now halted, wavered, and fell back. At this moment Terrill's battery of 24-pound howitzers rushed up, and in a few minutes was unlimbered and firing into the compact and advancing ranks of the enemy. Here was the turning point of the battle on the left. The enemy were only checked, not halted; then followed for two hours a contest of artillery and musketry at short range. The enemy began to waver, when Gen. Buell coming up, saw at a glance the chance and ordered a charge by brigades, at "double quick." The Confederates fell back for a quarter of a mile, became more confused, and at half past two that point of the field was cleared. The next divisions, of Gens. Crittenden and McCook, after an obstinate struggle, were equally successful. The divisions of Gens. McClelland and Hurlbut, nothing daunted by the reverses of the preceding day, fought with much bravery. On the right the contest was more severe, and longer continued. A design was manifested by the enemy to turn the flank of Gen. Wallace's division. This was thwarted, and the enemy steadily driven back until four P. M., when a general retreat took place on the right. Thus the original plan of the enemy was frustrated. It was his design to drive Gen. Grant into his transports and the river, or to capture his force in time to profit by the victory, and remove to the rear all the stores and munitions that would be taken. This was to be done before the arrival of Gen. Buell.

On the retreat of the Confederate army, the original ground, and even the tents of Gen. Grant's army, were recovered. No regular pursuit was attempted until the next day. The number of the Federal army engaged on Sunday, was estimated by Gen. Beauregard at five divisions of nine thousand men each, or forty-five thousand men. The reinforcements of Sunday night were estimated by him at twenty-five thousand from Gen. Buell's army, and eight thousand under Gen. Wallace, and the entire force on Monday fifty-three thousand. This estimate slightly exceeds the Federal force engaged, especially in the number of reinforcements furnished by Gen. Buell. On the other hand, the Confederate force was estimated at sixty thousand by the Union officers, which was undoubtedly an overestimate. Gen. Grant had a force somewhat less than the enemy on Sunday, but on Monday he outnumbered them. No official statement of numbers has been afforded on either side. The Federal loss was 1,735 killed, 7,882 wounded, and 8,956 taken prisoners. Total, 13,573. The Confederate loss was killed 1,728, wounded 8,012, missing 959. Total, 10,699.

At the close of the battle on the first day, Gen. Beauregard sent the following despatch to Richmond:

BATTLE FIELD OF SHILOH, April 6, }  
via Corinth and Chattanooga. }

*General S. Cooper, Adjutant-General:*

We have this morning attacked the enemy in a strong position in front of Pittsburg, and after a severe battle of ten hours, thanks to Almighty God, gained a complete victory, driving the enemy from every position.

The loss on both sides is heavy, including our Commander-in-Chief, Albert Sidney Johnston, who fell gallantly leading his troops into the thickest of the fight.

(Signed) G. T. BEAUREGARD, Gen'l Com'd'g.

In consequence of the reception of this message, President Davis sent the following Message to the Confederate Congress, then in session at Richmond, on the 8th of April:

*To the Senate and House of Representatives of the Confederate States of America:*

The great importance of the news just received from Tennessee induces me to depart from the established usages, and to make to you this communication in advance of official reports. From official telegraphic despatches, received from official sources, I am able to announce to you, with entire confidence, that it has pleased Almighty God to crown the Confederate arms with a glorious and decisive victory over our invaders.

On the morning of the 6th, the converging columns of our army were combined by its Commander-in-Chief, Gen. A. Sidney Johnston, in an assault on the Federal army, then encamped near Pittsburg, on the Tennessee river.

After a hard-fought battle of ten hours, the enemy was driven in disorder from his position, and pursued to the Tennessee river, where, under cover of the gunboats, he was at the last accounts endeavoring to effect his retreat by aid of his transports. The details of this great battle are yet too few and incomplete to enable me to distinguish with merited praise all of those who may have conspicuously earned the right to such distinction, and I prefer to delay our own gratification in recommending them to your special notice, rather than incur the risk of wounding the feelings of any by failing to include them in the list.

When such a victory has been won over troops as numerous, well-disciplined, armed, and appointed, as those which have just been so signally routed, we may well conclude that one common spirit of unflinching bravery and devotion to our country's cause must have animated every breast, from that of the Commanding General to that of the humblest patriot who served in the ranks. There is enough in the continued presence of invaders on our soil to chasten our exultation over this brilliant success, and to remind us of the grave duty of continued exertion, until we shall extort from a proud and vain-glorious enemy the reluctant acknowledgment of our right to self-government.

But an All-wise Creator has been pleased, while vouchsafing to us his countenance in battle, to afflict us with a severe dispensation, to which we must bow in humble submission. The last long, lingering hope has disappeared, and it is but too true that Gen. Albert Sidney Johnston is no more. The tale of his death is simply narrated in a despatch from Col. William Preston, in the following words:

"Gen. Johnston fell yesterday at half past two o'clock, while leading a successful charge, turning the enemy's right, and gaining a brilliant victory. A Minié ball cut the artery of his leg, but he rode on until, from loss of blood, he fell exhausted, and died without pain in a few moments. His body has been intrusted to me by Gen. Beauregard, to be taken to New Orleans, and remain until directions are received from his family."

My long and close friendship with this departed



chieftain and patriot forbids me to trust myself in giving vent to the feelings which this sad intelligence has evoked. Without doing injustice to the living, it may safely be asserted that our loss is irreparable. Among the shining hosts of the great and good who now cluster around the banner of our country, there exists no purer spirit, no more heroic soul, than that of the illustrious man whose death I join you in lamenting.

In his death he has illustrated the character for which through life he was conspicuous—that of singleness of purpose and devotion to duty—with his whole energies. Bent on obtaining the victory which he deemed essential to his country's cause, he rode on to the accomplishment of his object, forgetful of self, while his very life-blood was fast ebbing away. His last breath cheered his comrades on to victory. The last sound he heard was their shout of victory. His last thought was of his country, and long and deeply will his country mourn his loss. JEFFERSON DAVIS.

On the 10th of April, President Lincoln, having received reports of the battles at Pittsburg Landing, or Shiloh, issued the following proclamation:

WASHINGTON, April 10, 1862.

It has pleased Almighty God to vouchsafe signal victories to the land and naval forces engaged in suppressing an internal rebellion, and at the same time to avert from our country the dangers of foreign intervention and invasion.

It is therefore recommended to the people of the United States that, at their next weekly assemblages in their accustomed places of public worship, which shall occur after the notice of this Proclamation shall have been received, they especially acknowledge and render thanks to our Heavenly Father for these inestimable blessings; that they then and there implore spiritual consolation in behalf of all those who have been brought into affliction by the casualties and calamities of sedition and civil war, and that they reverently invoke the Divine guidance for our national counsels, to the end that they may speedily result in the restoration of peace, harmony, and unity throughout our borders, and hasten the establishment of fraternal relations among all the countries of the earth.

In witness whereof I have hereunto set my hand and caused the seal of the United States to be affixed. Done at the city of Washington, this tenth day of April, in the year of our Lord one thousand eight hundred and sixty-two, and of the independence of the United States the eighty-sixth.

ABRAHAM LINCOLN.

By the President—WM. H. SEWARD, Secretary of State.

On the 8th Gen. Sherman, with a body of cavalry and infantry, advanced on the Corinth road. His progress was at first checked by a force of the enemy's cavalry, which afterward was driven back. The roads were found in a bad state, in consequence of the heavy rain on Sunday night, and strewn with abandoned wagons, ambulances, and limber boxes. A general hospital, containing about two hundred and ninety wounded Confederate soldiers, was also found. The force of Gen. Sherman returned to camp at night.

It was charged against Gen. Grant that the commencement of the battle was a surprise to the Federal forces, and that he was absent from the field until some hours after. In reply he said: "As to the talk of our being surprised, nothing could be more false. If the enemy had sent us word where and when they would attack, we could not have been better prepared. Skirmishing had been going on for two days between our reconnoitring parties

and the enemy's advance. I did not believe, however, that they intended to make a determined attack, but simply to make a reconnoissance in force. My headquarters were at Savannah, though I usually spent the day at Pittsburg. Troops were constantly arriving to be assigned to the different brigades and divisions. All were ordered to report at Savannah, making it necessary to keep an office and some one there. I was also looking for Buell to arrive, and it was important that I should have every arrangement complete for his crossing and transit to this side of the river."

Gen. Beauregard issued the preliminary orders for his troops to move from Corinth at one o'clock on the morning of the 3d of April. The movement did not commence until during the forenoon. It was expected to reach the Federal lines in time to commence the attack on the 5th. They arrived too late in the afternoon of that day to attack. It could not have been with the advance of this force that "skirmishing had been going on for two days."

On the 9th of April, Maj.-Gen. Halleck, with a portion of his staff, left St. Louis for Pittsburg Landing, to assume command in the field. His first efforts were devoted to reorganizing the army. Two days after his arrival, an expedition was sent under convoy of the gunboats to destroy the railroad bridge over Bear Creek, seven miles inland from Chickasaw. This was successfully done by Gen. Sherman, and cut the communication between Richmond, Va., and Corinth. The state of the roads delayed for some days any movement of importance. Frequent skirmishes, however, took place with the Confederate infantry and cavalry hovering near. On the 2d of April, Gen. Pope, with his division, numbering about 25,000, arrived at Pittsburg Landing from New Madrid. On the 27th, orders were issued by Gen. Halleck for the army to hold itself in readiness for an immediate movement. Gen. Grant's divisions formed the right wing of the army, those of Gen. Buell the centre, and those of Gen. Pope the left wing. Gens. Grant and Buell retained the immediate command of their respective armies. The advance of the army was now gradually commenced. Day after day a division or a brigade was moved a few miles, and the outposts extended. On the 1st of May, Monterey was occupied. It is a small village in McNairy Co., Tenn., four miles from the Mississippi line, and about midway between Pittsburg Landing and Corinth. A few days previously, an expedition under Gen. Wallace had gone as far as Purdy, about twenty miles west of Pittsburg Landing, and destroyed the bridge of the railroad connecting Corinth with Jackson.

On the 2d of May, Gen. Beauregard issued the following address to his soldiers:

HEADQUARTERS OF THE FORCES AT CORINTH, }  
MISSISSIPPI, May 2, 1862. }

*Soldiers of Shiloh and Elkhorn:* We are about to meet once more, in the shock of battle, the invaders

of our soil, the despoilers of our homes, the disturbers of our family ties, face to face, hand to hand. We are to decide whether we are to be freemen or vile slaves of those who are free only in name, and who but yesterday were vanquished, although in largely superior numbers, in their own encampments, on the ever-memorable field of Shiloh. Let the impending battle decide our fate, and add a more illustrious page to the history of our revolution—one to which our children will point with noble pride, saying, "Our fathers were at the battle of Corinth." I congratulate you on your timely junction. With your mingled banners, for the first time during this war, we shall meet our foe in strength that should give us victory. Soldiers, can the result be doubtful? Shall we not drive back into Tennessee the presumptuous mercenaries collected for our subjugation? One more manly effort, and, trusting in God and the justness of our cause, we shall recover more than we have lately lost. Let the sound of our victorious guns be echoed by those of the army of Virginia on the historic battle field of Yorktown.

G. T. BEAUREGARD,

General Commanding.

J. M. OTEY, Acting Assistant Adjutant-General.

On the 3d of May, the army, commanded by Gen. Halleck, numbering 108,000 men, was within eight miles of Corinth. The bridges burned had been rebuilt, and the roads had become dry enough to render transportation easy. Few can conceive the difficulty of moving such a mass of men with their tents, baggage, artillery, and supplies, over an uneven, marshy country, covered with woods, and without roads.

Corinth is a small village in the northeast corner of Mississippi, ninety miles east from Memphis, and about twenty miles west from the Tennessee river. The Memphis and Charleston railroad runs through it from east to west, and the Mobile and Ohio from north to south. The country between it and the Tennessee river is very uneven, broken into ridges of hills and abrupt valleys, and covered with a heavy forest. The bridges over the creeks had been destroyed; the roads over the marshes had been torn up, and timber had been felled in great quantities over them.

On the same day Gen. Paine, with his division, made a reconnoissance to Farmington, five miles northwest of Corinth, and found about 4,500 Confederate troops, who, on being attacked, retreated with a loss of 80 killed and 200 taken prisoners. At the same time an artillery reconnoissance to Glendale on the Charleston and Memphis railroad, destroyed two trestle bridges and some of the track.

At this time the organization of Gen. Halleck's force had been somewhat changed. Gen. Thomas was assigned to the command of the right wing, composed of five divisions, viz.: his own, Hurlbut's, Sherman's, that of Gen. Smith, deceased, and Gen. Davies'; the centre consisted of four divisions under Gens. McCook, Wood, Nelson, and Crittenden; the left under Gen. Pope, to which was added one division of Gen. Curtis's army from Arkansas. Gen. Grant was appointed second in command. The reserve under Gen. McClelland consisted of his own and Gen. Wallace's divisions. The advance upon Corinth was

made with the extremity of each wing thrown back in echelons to prevent a flank attack.

Meantime the Confederate forces at Corinth were active in strengthening their position and accumulating reinforcements. Pensacola and New Orleans had at this time been captured by the Federal forces, and Gen. Lovell had with his force arrived at Corinth from the neighborhood of the latter city. On the 9th, a strong Confederate force drove in the Federal pickets beyond Farmington, and advanced upon the brigade occupying the farther side of the creek in front of the Federal camp. The brigade maintained its position for some time, but Gen. Pope, finding it would be necessary to move his whole force across the creek, contrary to orders, in order to sustain it, directed it to retire.

Great as was the army of Gen. Halleck, the Confederates were believed to be stronger, and the people of the Southern States now looked forward to a signal and brilliant victory.

The advance of the Federal lines was slow, and on the 21st their batteries were within three miles of Corinth. The skirmishing of the pickets now increased every day, and soon became constant along the entire line. Almost daily the artillery was engaged, and the hour for battle was close at hand.

The railroad communication to the northward and eastward of Corinth had been destroyed at Purdy and Glendale. With a view to prevent still further, so far as it was in his power, either the reinforcement or the retreat of the Confederate armies at Corinth, Gen. Halleck directed that the railroad to the southward of Corinth and in the direction of Mobile should be also cut. To effect this, Col. Elliott, with two regiments of cavalry, started on the night of the 27th, and early on the 30th reached Booneville, 24 miles south of Corinth. A large amount of stores was found and destroyed, consisting of five railroad cars loaded with small arms, five loaded with loose ammunition, six with officers' baggage, and five with subsistence stores, harness, saddles, &c. Some hundreds of sick Confederate soldiers were paroled. The trains, engines, and depot were burned.

On the 28th, Gen. Halleck sent the following despatch to Washington:

HEADQUARTERS DEPARTMENT MISSISSIPPI, }  
CAMP ON CORINTH ROAD, May 28. }

Hon. E. M. Stanton, Secretary of War:

Three strong reconnoitring columns advanced this morning on the right, centre, and left, to feel the enemy and unmask his batteries. The enemy hotly contested his ground at each point, but was driven back with considerable loss. The column on the left encountered the strongest opposition. Our loss was twenty-five killed and wounded. The enemy left thirty dead on the field. The losses at other points are not yet ascertained. Some five or six officers and a number of privates were captured. The fighting will probably be renewed to-morrow morning at day-break. The whole country is so thickly wooded that we are compelled to feel our way.

H. W. HALLECK, Major-General.

The following despatches were sent on the 30th:

NEAR CORINTH, May 30, 1862.

*Hon. E. M. Stanton, Secretary of War :*

Gen. Pope's heavy batteries opened upon the enemy's trenchments yesterday, about 10 A. M., and soon drove the rebels from their advanced battery.

Maj.-Gen. Sherman established another battery yesterday afternoon within one thousand yards of their works, and skirmishing parties advanced at daybreak this morning.

Three of our divisions are already in the enemy's advanced works, about three quarters of a mile from Corinth, which is in flames.

The enemy has fallen back of the Mobile railroad.  
H. W. HALLECK.

NEAR CORINTH, May 30, 1862.

*Hon. Edwin M. Stanton, Secretary of War :*

Our advanced guard are in Corinth. There are conflicting accounts as to the enemy's movements. They are believed to be in strong force on our left flank, some four or five miles south of Corinth, near the Mobile and Ohio railroad.

H. W. HALLECK, Major-General.

HEADQUARTERS CAMP NEAR CORINTH, May 30.

*Hon. E. M. Stanton, Secretary of War :*

The enemy's position and works in front of Corinth were unexpectedly strong. He cannot occupy a stronger position in his flight.

This morning he destroyed an immense amount of public and private property, stores, provisions, wagons, tents, &c.

For miles out of the town the roads are filled with arms, haversacks, &c., thrown away by his flying troops.

A large number of prisoners and deserters have been captured, and are estimated by Gen. Pope at two thousand.

Gen. Beauregard evidently distrusts his army, or he would have defended so strong a position. His troops are generally much discouraged and demoralized. In all their engagements for the last few days their resistance has been weak.

H. W. HALLECK, Major-General.

The Confederate officers began to remove theirsick from Corinth preparatory to an evacuation on Monday, the 26th of May. On the next day, Tuesday the 27th, Gens. Beauregard and Bragg were making arrangements for falling back, which process was completed in great haste on Thursday night, the 29th. On Wednesday the entire line of Gen. Halleck was advanced from one half to three quarters of a mile and up into easy range of the enemy's works. The heavy siege guns were put into position on that day on the works thrown up by the advanced column. This movement throughout was hotly contested, the enemy doubtless seeking to keep their opponents at a safe distance if possible, until their evacuation should be completed. They continued to show an unbroken front and to work their batteries with energy and without interruption throughout that and the next day. On Thursday morning operations were resumed with the same earnestness as on Wednesday. The enemy appeared still in position, and contested every inch of the Union advance with the utmost determination. At nine o'clock on that morning, however, their musketry firing ceased, and was not again resumed. After that hour there were no further close engagements. The batteries on both sides, however, were kept in play, though a gradual diminution of the en-

emy's fire was observable as the day wore away, and before night it had wholly ceased. During the night heavy explosions were heard in the enemy's works, which were conjectured to be the destruction of their magazines and ammunition, which subsequently proved true. Flames were also seen issuing from the town in the latter part of the night. These indications were plain to those in the advance of the Federal lines, and were understood to be the movements for an evacuation.

As no opposition was made to the advance on Friday morning, some officers dashed ahead to satisfy themselves of the enemy's position. The first party rode into the town at 6h. 30m. in the morning, and then was discovered the whole extent of the success gained. Destruction, waste, and desolation were visible on every hand. Huge piles of commissary stores were smouldering in the flames. The remains of buildings destroyed were conspicuous on the streets. The enemy had fled, taking care that what they could not carry away should at least not be left for the victors. One large warehouse, filled with provisions, was all that remained undamaged of boundless stores of similar goods, sufficient to withstand a much longer siege. Sacks were torn open, barrels broken, hogsheds knocked to pieces, and their contents mixed in common piles, upon and about which huge bonfires had been lit.

So complete was the evacuation that not only was the Confederate army successfully withdrawn, but they took every piece of ordnance. A large quantity of ammunition was left behind in a damaged state.

At Corinth the Confederate line of fortifications was about fifteen miles long, with strong batteries or redoubts at every road or assailable point. Between the fortifications and a marshy stream covering the whole front, the dense timber had been cut down to form a very strong abattis, through which no cavalry or artillery could have passed, nor even infantry except as skirmishers. The lines thrown up by the Federal troops at the end of the day's advance were mere rifle pits, while the fortifications around Corinth were, as stated above, a strong continuous line, constructed with great care and labor, and, independent of their position, were in themselves immeasurably stronger than the mere precautionary defences on the Federal part against any sudden sortie of the enemy. The Confederate works, moreover, were on the brow of a ridge considerably higher than any in the surrounding country, at the foot of which was a ravine correspondingly deep. The zigzag course of the line gave to the defenders the command of all the feasible approaches, and hundreds could have been mowed down at every step made by an assailing army.

At the time of the evacuation of Corinth the hot weather of summer had commenced and the period of low water in the rivers was close at hand. Even the Tennessee could not be relied upon as a route by which to transport

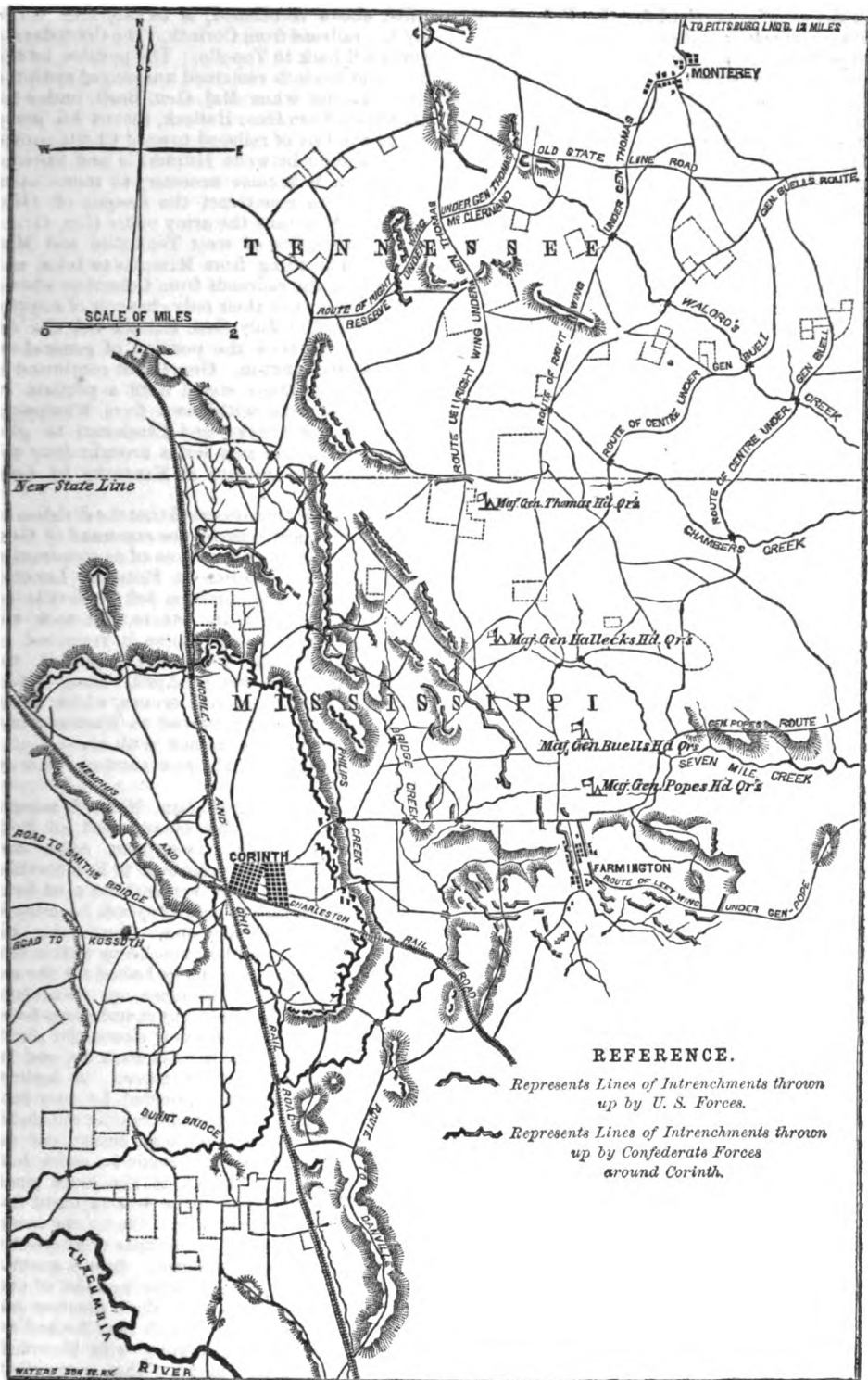

all the supplies required for the Federal army. Gen. Halleck consequently took immediate steps to open a new line direct to Columbus, Ky., to which place the railroad was speedily repaired. These circumstances would impose a limit upon the military operations of Gen. Halleck's army for some months. Even if Corinth was evacuated and a part of the Confederate force withdrawn entirely, no serious blow could be struck by Gen. Halleck. These considerations must have presented themselves to the Confederate Government at the time when Richmond was closely pressed by Gen. McClellan, and really in danger of capture. Without doubt they exerted an influence in producing the determination to evacuate Corinth. And when it became evident that the position could not be held against the force that was advancing upon it, they pointed out the manner in which this evacuation could be turned to advantage.

At this time Gen. McClellan had crossed the Chickahominy, Gen. Banks was retreating before Gen. Jackson up the Virginia valley, Forts Pillow and Randolph and the city of Memphis had surrendered, and a Federal force was making an attack on Vicksburg.

The pursuit of the retreating forces of Gen. Beauregard was made as follows: On the morning after the evacuation, Gen. Pope's forces entered the town about twenty minutes before seven o'clock, just as the last of the Confederate cavalry were leaving. One company of cavalry, being Gen. Pope's escort, pushed after them, and had a brisk skirmish, in which several were killed and captured. The pursuit, however, was arrested by the burning of a bridge over a swampy creek, and the cavalry returned. A brigade of cavalry and a battery under Gen. Granger were then sent out by Gen. Pope on the Booneville road. It left Farmington at noon on the 30th, and the same day came up with the rear guard of the enemy posted on Tusumbia Creek eight miles south of Corinth. The next day they were driven out, and on Sunday, June 1, the pursuit was recommenced. Gen. Granger passed Rienzi only two hours behind the retreating army, and found the bridges between that place and Booneville so recently fired that the timbers were nearly all saved. That afternoon the advance overtook the retreating Confederate rear four miles from Booneville, and pursued it within one mile of the town, and halted for the night. At five o'clock on the next morning the town was entered, and skirmishing was kept up all day with the Confederates on every road leading westward or southward as far as Twenty Mile Creek. On the next day a reconnoissance with force was made toward Baldwin, and the Confederate force driven across Twenty Mile Creek; and on the 4th another reconnoissance was made by Col. Elliot via Blocklands, with similar results. On the 10th Baldwin and Gun-town were occupied by Federal troops, which was the termination of the pursuit. Boone-

ville, above mentioned, is twenty-four miles by the railroad from Corinth. The Confederate force fell back to Tupello. The position of the forces at Corinth remained unchanged until the 10th of June, when Maj.-Gen. Buell, under instructions from Gen. Halleck, moved his army along the line of railroad toward Chattanooga. He was then between Huntsville and Stevenson, when it became necessary to move upon Louisville to counteract the designs of Gen. Bragg. Meantime the army under Gen. Grant occupied the line of west Tennessee and Mississippi extending from Memphis to Iuka, and protecting the railroads from Columbus south, which were then their only channels of supply. On the 28d of July Gen. Halleck left the department to take the position of general-in-chief at Washington. Gen. Grant continued in the position above stated until a portion of his troops were withdrawn from Mississippi and sent to Kentucky and Cincinnati to give confidence to the new levies brought into the field upon the invasion of Kentucky by Gen. Bragg.

It will have been observed that the division of Gen. Buell's army, under the command of Gen. Mitchell, has not been spoken of as cooperating with the other divisions at Pittsburg Landing and Corinth. This division left Nashville on the same day with the others, but took the road to Murfreesboro. There it remained in occupation of the place and repairing the bridges until the 4th of April. Long before this time the Confederate troops, which occupied Nashville and retreated to Murfreesboro, had withdrawn and united with those under Gen. Beauregard on the new southern line of defence.

On the 4th of April, Gen. Mitchell marched to Shelbyville, the county seat of Bedford county, Tenn., twenty-six miles distant. On the 7th he advanced to Fayetteville, twenty-seven miles farther, and the next forenoon, the 8th, fifteen miles beyond, he crossed the State line of Alabama. Continuing his march six miles farther, and being within ten miles of Huntsville, Ala., he halted for the artillery and infantry to come up. No tents were pitched. The men lay round camp fires. Just as the moon was going down, the shrill bugle call was sounded. All were up, and in a few minutes ready to move. A battery was put in advance, supported by two brigades. Four miles from Huntsville, the shrill whistle of a locomotive was heard, and in a few minutes the train came in sight, and was stopped by the call of the brass guns of the battery. The train was captured together with 159 prisoners. On to the town was now the order. The citizens were quietly sleeping as the army entered. Says a spectator of the scene: "The clattering noise of the cavalry aroused them from their slumber ere the dawn of the morning, and they flocked to door and window, exclaiming with blanched cheek and faltering tongue, 'They come, they

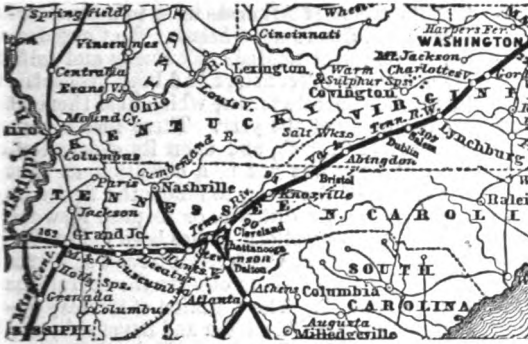

come, the Yankees come!' Never in the history of any military movement was surprise so complete. Men rushed into the streets almost naked, the women fainted, the children screamed, the darkies laughed, and for a short time a scene of perfect terror reigned. This state of affairs soon subsided."

Col. Gazley, of the 37th Indiana regiment, was appointed provost marshal, and his regiment occupied the city as guard. Then commenced an examination of the results of this bloodless capture. At the railroad depot were found seventeen first-class locomotives and a great quantity of passenger and freight cars, and at the foundery two or three cannon, together with several small arms. Gen. Mitchell soon made good use of the engines. Before the close of day, one hundred miles of the Memphis and Charleston railroad were in his possession, stretching in one direction as far as Stevenson, and in the other as far as Decatur. At the latter place, the entire camp equipage of a regiment was captured. From Decatur he pushed on at once to Tuscumbia.

Thus, without the loss of a single life, Gen. Mitchell placed his army midway between Corinth and Chattanooga, prevented the destruction of a fine bridge at Decatur, opened communication with Gen. Buell, and also the navigation of the Tennessee. The occupation of Huntsville also cut off all communication between the east and west by the Memphis and Charleston railroad. The expedition east on the railroad, under Col. Sill, penetrated as far as Stevenson at the junction of the Chattanooga road, at which place five locomotives and an amount of rolling stock were captured. An expedition went as far south from Tuscumbia as Russellville. Lagrange and Florence were also visited, and Confederate property of the military kind was found.

This extension of Gen. Mitchell's lines to hold the railroad rendered his situation precarious. Soon the enemy began to gather in force and threaten him. His course however received the commendation of the War Department. He was raised to the rank of a major-general, and ordered to report directly to the department, and his force was constituted an independent corps. But he got

no reinforcements. He was left in such a condition that he at first hardly had anything to report but that he had been gradually driven from those positions, the gaining of which had made him a major-general. On his right, the enemy were now in force, and picket skirmishing was constant. On his left, at Chattanooga, a strong force threatened his rear and the safety of Nashville. In his front, cavalry came up and attacked his line at times. Gen. Halleck sent to him 100,000 rations under convoy of a gunboat. Of these 40,000 were burned to prevent their capture. On the 24th of April, the retreat from Tuscumbia commenced.

On the 26th the bridge at Decatur was crossed, when it was fired and burned. It was the only crossing of the Tennessee east of Florence, above the head of navigation, and west of Bridgeport near Chattanooga. The bridge was destroyed in an hour and a half, but before its destruction was complete, the enemy's cavalry appeared on the opposite side. Having returned to Huntsville, the right wing of the force commenced operations toward Chattanooga.

On the 30th of April, an expedition was sent to Bridgeport near Stevenson, the result of which placed under the control of Gen. Mitchell the bridge across the river. As there was no bridge below his position since the destruction of the one at Decatur, and as he had control of the one above near Chattanooga, and as his communication between the extremes of his line was by railroad, which was in his possession, and the Tennessee river lay in front of him, on the farther side of which was all the enemy he anticipated, he thus closed his report to the Secretary of War under date of May 1: "The campaign is ended, and I now occupy Huntsville in perfect security, while all of Alabama north of the Tennessee river floats no flag but that of the Union." It was stated that if Gen. Mitchell had been sustained with a sufficient force, he would have crossed the Tennessee river at its extreme southern point in Alabama, and reached Gunter's Landing—a march of forty miles thence would have placed in his possession Gadsden on the Coosa river, where he could have destroyed the steamboats on the river, or seized them and proceeded to Rome and destroyed large armories and founderies. From Gunter's Landing there is also a fine road to Rome, eighty miles distant. In two days his cavalry could have passed that distance, destroyed the founderies at Rome, and captured engines and cars enough at that place and Kingston to have enabled him to proceed up the road with an armed force to protect them in burning the bridges. This movement would have cut off Gen. E. Kirby Smith, then advancing upon Huntsville, from reinforcements or retreat. The Confederate forces in Knoxville, Greenville, and Cumberland Gap, in east Tennessee, and even in western Virginia, would all have been dangerously exposed by

little more extended operations along the railroads by Gen. Mitchell.

Subsequently he advanced upon Chattanooga, which compelled the Confederate forces in eastern Tennessee to make a backward movement. Only a single stem of railroad connects Chattanooga with Atlanta, and thence connects with other parts of Georgia, Alabama, and South Carolina, and its loss would compel evacuation above, as in the case of Bowling Green. Several expeditions were sent out by Gen. Mitchell during the month of May against small bands of cavalry upon the same side of the river. One or two skirmishes of considerable spirit, and with respectable numbers, also took place. On the 6th of June, Gen. Negley, from the opposite side of the river, made an attack with his artillery upon Chattanooga. This was replied to from some earthworks. On the next day a considerable force under Gen. E. K. Smith opened fire upon Gen. Negley, but were compelled to retire. Chattanooga was finally abandoned by the Federal force in consequence of the difficulty of procuring supplies.

On the advance of Gen. Buell, this division of his army under Gen. Mitchell was placed under the command of Gen. Rosseau, and Gen. Mitchell was ordered to the command at Port Royal, South Carolina.

The result of the military operations that have been thus far described, was at this time of the year such as to leave in the hands of the Confederate Government a large military force, which it could use without additional hazard wherever it pleased, while the Federal Government, struck with panic from other causes, was actually calling upon the governors of the loyal States to hurry forward to its protection even three months' volunteers. The acquisition of territory, however, was all on the side of the Federal Government, which had got its hands so full in proportion to its military preparations, that it must either relinquish some portion of it or submit to defeat somewhere, if its antagonist was active, skilful, and dexterous. This state of affairs culminated in the midst of the Virginia campaign, and it was decisive not only of that campaign, but it presented to the world magnificent displays of the skill and power of the respective antagonists.

It has been said that the Confederate Government had a large military force with which it was free to act, without additional hazard. This force consisted of part of the levies of the previous year, some of the levies raised by the governors of the States, under a call from President Davis in February of this year, and some of the troops beginning to come up under the conscription act passed by the Confederate Congress early in April. In Missouri the success of Gen. Curtis had been such as to drive out all the regular Confederate troops, and he had established himself just within the borders of Arkansas. But the requisition upon him to send ten regiments to the assistance of Gen. Halleck, so limited his ability for offensive operations,

that the troops of Arkansas were to a considerable extent free to act wherever the Confederate Government needed. Kentucky and middle and western Tennessee had been evacuated by the Confederate forces, which held them at the beginning of the year. These forces congregated at Corinth, and upon its evacuation, the vast army was not in a condition, at that hot season of the year, to follow the fugitives any considerable distance, or to push forward its offensive operations, as has been before observed. A limited Confederate force was therefore kept in the field, to observe the operations of Gen. Halleck. The cessation of military operations against Charleston and Savannah, and also in North Carolina, by the Federal Government, caused the Confederate Government to keep no more than a force of observation in the field, and left it at liberty to concentrate its other troops wherever their presence might be most needed. These troops were therefore sent to Virginia, to engage in the campaign going on in that State.

The position and number of the Federal troops in Virginia at the beginning of the year have already been stated (*see* page 24). The distinct bodies of men were those under Gen. Wool at Fortress Monroe and Newport News; those under Gen. Hooker south of Washington; those under Gen. McClellan southwest of Washington; those under Gens. Keyes and Casey in and around Washington; those under Gen. Stone at and near Pooleville, and those under Gen. Banks near Darnestown with detachments on the Potomac to Williamsport. Cumberland was the headquarters of Gen. Kelly, and Grafton in western Virginia, on the line of the Baltimore and Ohio Railroad, the headquarters of Gen. Rosecrans, while Gen. Cox was up the Kanawha valley.

On the 5th of January Gen. Lander arrived at Hancock, on his way to Cumberland to relieve Gen. Kelly, who was sick. He found the enemy under Gen. Jackson, on the other side of the Potomac, in considerable strength. It had been designed for two months that Gen. Jackson should move northwest toward Romney; but he was delayed by the impression of the Confederate Government that the Federal army would make a general advance, and risk a battle during the winter. On the 8d or 4th of January he left Winchester and moved northward toward Hancock, a distance of forty miles, and attacked four companies of Federal troops stationed at Bath, driving them to Hancock, where, having been reinforced by Gen. Lander, they made a stand. Here Gen. Jackson made a feint attack by throwing some shells across the Potomac, which did only slight damage. He then moved westward with the intention of coming into Romney, on the Union left, by way of Springfield, and thus cut off the supplies from Cumberland and the railroad. The relative positions of Winchester, Hancock, and Romney are at the points of an equilateral triangle: Hancock north of Winchester, and Romney northwest

The day before Gen. Jackson retired from before Hancock, Gen. Kelly, who was in Cumberland, sent an order to Col. Dunning, the commandant at Romney, to make an attack on the enemy's force stationed at Blue's Gap, a strong position, sixteen miles from Romney, on the road to Winchester. On the night of the 6th an expedition, consisting of the 4th, 5th, 7th, and 8th Ohio, 14th Indiana, and 1st Virginia, with two companies of cavalry and a battery, was sent to Blue's Gap, and made an attack upon the enemy, who, being in small force, were completely driven out. At this time Gen. Loring, with a considerable Confederate force, was within six miles of the gap, expecting the Federal column to push on and attack him. Meantime, as soon as Gen. Jackson left Hancock, Gen. Lander, anticipating his intentions, proceeded to Cumberland to Gen. Kelly, and assumed the chief command, and thence to Romney, where he arrived on the night of the Tuesday on which the expedition returned from Blue's Gap. Everything was put in readiness for a struggle. On Friday following it was reported that Gen. Jackson, in command of his right wing of ten thousand men, was within twelve miles east of Springfield, resting his men, and waiting for his other forces to get into position. His centre under Gen. Loring, about eight thousand strong, was at Blue's Gap, and his left wing of three thousand had moved up from toward Moorsfield, and taken position on the New Creek road, some six miles in the rear of Romney. Thus, excepting at one point, Romney was completely surrounded by Gen. Jackson. If Gen. Lander could march north eight miles, to the Springfield crossing of the South Branch of the Potomac, before Gen. Jackson could march west twelve to Springfield, then Gen. Lander could get beyond him, or fight him with ten thousand men, at a less disadvantage than in Romney, where Gen. Jackson would concentrate twenty thousand. The entire force of Gen. Lander was about four thousand five hundred men. On Friday night everything was ready for the march. The sick, the hospital, and commissary stores were sent forward under a strong guard, and at midnight the rear guard of Gen. Lander withdrew from the town. It had rained during the day, and the rate of advance over the bad roads was a mile and a quarter to the hour. At five o'clock the next morning Gen. Lander reached Springfield. The men were so tired and exhausted that, after making fires of the fences, they lay down in files on the cold, wet ground and slept. In two hours they were again on the march. But Gen. Jackson, instead of following, went to Romney, and thence retired to Winchester, leaving the former place occupied by Gen. Loring. He also evacuated it after a few days, partly in consequence of Gen. Lander having gathered his forces, and prepared for a march upon it. Subsequently Moorsfield was captured, and Bloomery Gap, by Gen. Lander. On the 11th of February Gen. Lander telegraphed to Gen.

McClellan, the commander-in-chief, as follows: "The railroad was opened to-day to Hancock; also the telegraph. Papers taken, and my own reconnoissance to the south, prove the country clear, and Jackson and Loring in Winchester. The enemy have been driven out of this department."

The failure of Gen. Lander's health compelled him soon after to resign his command.

The time was now approaching when some movement should begin among the vast forces encamped in northeastern Virginia. With the Confederate Government, which still adhered to the defensive policy, the question was, whether it should maintain its advanced position before Washington, or fall back on Richmond? Its position was so well fortified that it could resist any attack in front, but would be in danger if either of its flanks were turned. Winchester, in the Shenandoah Valley, was the extreme point on the northwest occupied by the Confederate army, and Aquia Creek and Matthias Point on the southeast. This extent of line was too great to be maintained before the vast Federal forces organized in front. The flanks might thus be turned by the way of Leesburg on the north, or the Potomac on the south, and serious disaster would ensue. At the same time, the farther Gen. McClellan was drawn from his position before being encountered, so much the easier would his army be overcome, and at a greater cost to the North. These and similar considerations determined the Confederate Government to evacuate the position held by its army at Manassas. This measure was, however, not executed until March.

On the 30th of January, Gen. Beauregard, having been ordered to command in Kentucky and Tennessee, issued the following address to the soldiers at Manassas:

HEADQUARTERS FIRST CORPS ARMY OF THE POTOMAC, }  
Near CENTREVILLE, January 30, 1862. }

*Soldiers of the First Corps Army of the Potomac:*

My duty calls me away, and to a temporary separation from you. I hope, however, to be with you again, to share your labors and your perils, and in defence of our homes and our rights, to lead you to new battles, to be crowned with signal victories.

You are now undergoing the severest trial of a soldier's life; the one by which his discipline and capacity for endurance are thoroughly tested. My faith in your patriotism, your devotion and determination, and in your high soldierly qualities, is so great that I shall rest assured you will pass through the ordeal resolutely, triumphantly. Still, I cannot quit you without deep emotion, without even deep anxiety, in the moment of our country's trials and dangers. Above all, I am anxious that my brave countrymen, here in arms, fronting the haughty array and muster of Northern mercenaries, should thoroughly appreciate the exigency, and hence comprehend that this is no time for the army of the Potomac—the men of Manassas—to stack their arms and quit, even for a brief period, the standards they have made glorious by their manhood. All must understand this, and feel the magnitude of the conflict impending, the universal personal sacrifices this war has entailed, and our duty to meet them as promptly and unblenchingly as you have met the enemy in line of battle.

To the army of the Shenandoah I desire to return my thanks for their endurance in the memorable march to



my assistance last July, their timely, decisive arrival, and for their conspicuous steadiness and gallantry on the field of battle.

Those of their comrades of both corps, and of all arms of the army of the Potomac, not so fortunate as yet to have been with us in conflict with our enemy, I leave with all confidence that on occasion they will show themselves fit comrades for the men of Manassas, Bull Run, and Ball's Bluff. G. T. BEAUREGARD,  
General Commanding.

Twelve months had now nearly passed since the first soldiers of the Confederate army took the field, and their term of enlistment was about to expire. This fact is not only referred to in the address of Gen. Beauregard, but it was made the occasion of the following address by Gen. Johnston, now in command of the same forces:

HEADQUARTERS, DEPARTMENT OF NORTHERN VIRGINIA, }  
February 4, 1862. }

**SOLDIERS:** Your country again calls you to the defence of the noblest of human causes. To the indomitable courage already exhibited on the battle field, you have added the rarer virtues of high endurance, cheerful obedience, and self-sacrifice. Accustomed to the comforts and luxuries of home, you have met and borne the privations of camp life, the exactions of military discipline, and the rigors of a winter campaign. The rich results of your courage, patriotism, and unflinching virtue are before you. Intrusted with the defence of this important frontier, you have driven back the immense army which the enemy had sent to invade our country, and to establish his dominion over our people by the wide-spread havoc of a war inaugurated without a shadow of constitutional right, and prosecuted in a spirit of ruthless vengeance. By your valor and firmness, you have kept him in check, until the nations of the earth have been forced to see us in our true character—not dismembered and rebellious communities, but an empire of confederate States, with a constitution safe in the affections of the people, institutions and laws in full and unobstructed operation, a population enjoying all the comforts of life, and a citizen soldiery who laugh to scorn the threat of subjugation.

Your country now summons you to a noble and a greater deed. The enemy has gathered up all his energies for a final conflict. His enormous masses threaten us on the west; his naval expeditions are assailing us upon our whole southern coast; and upon the Potomac, within a few hours' march, he has a gigantic army, inflamed by lust and maddened by fanaticism. But the plains of Manassas are not forgotten, and he shrinks from meeting the disciplined heroes who hurled across the Potomac his grand army, routed and disgraced. He does not propose to attack this army so long as it holds its present position with undiminished numbers and unimpaired discipline; but, protected by his fortifications, he awaits the expiration of your term of service. He recollects that his own ignoble soldiery, when their term of service expired, "marched away from the scene of conflict to the sound of the enemy's cannon," and he hopes that at that critical moment Southern men will consent to share with them this infamy. Expecting a large portion of our army to be soon disbanded, he hopes that his immense numbers will easily overpower your gallant comrades who will be left here, and thus remove the chief obstacle to his cherished scheme of Southern subjugation.

The Commanding General calls upon the twelve months' men to stand by their brave comrades who have volunteered for the war, to re-volunteer at once, and thus show to the world that the patriots engaged in this struggle for independence will not swerve from the bloodiest path they may be called to tread. The enemies of your country, as well as her friends, are watching your action with deep, intense, tremulous interest. Such is your position that you can act no obscure part. Your decision, be it for honor or dis-

honor, will be written down in history. You cannot, you will not, draw back at this solemn crisis of our struggle, when all that is heroic in the land is engaged, and all that is precious hangs trembling in the balance.  
JOS. E. JOHNSTON, Major-General C. S. A.

It was not the purpose of Gen. McClellan while commander-in-chief to move on Centreville, but by the lower Chesapeake upon Richmond. His object was to capture and hold Chattanooga, Tenn., before the army of the Potomac advanced. In this, however, he was overruled by the President, who, on the 27th of January, issued an order, as above stated, for a general advance of all the armies on the 22d of February. This order was thus undoubtedly premature; and while it served to present the President before the country as anxious for a movement, it was really of no benefit to the cause, but, on the contrary, an actual injury. Previous to its issue a change had been made in the head of the War Department. Secretary Simon Cameron had resigned and was succeeded by Edwin M. Stanton; neither was a man of military education or experience.

The effects upon the Confederate States of the movements made in consequence of this order were thus described at Richmond: "Had not the impatience of the Northern people and the pressure of the European Cabinets forced the hand of McClellan, and had he been able to assemble and arrange his troops and stores in the position he desired, without a conflict to arouse the attention of the Southern people to what was going on, our condition in April and May would have been tenfold more dangerous than it now is. The disasters we have suffered are mortifying to us and exhilarate our enemies; but they have started without crippling the Confederacy. Had it lain still two months more, with the army dwindling daily under the furlough system, disgusted with the inaction of stationary camps, while the Government was squabbling with the Generals and the people sinking into indifference, we would have been overrun between the 15th of April and the 1st of May."

Gen. Lander having cleared his department of the forces of the enemy, a movement was now commenced lower down the Potomac by a portion of Gen. Banks's command. On the 24th of February the 28th Pennsylvania regiment, Col. Geary, crossed the Potomac from Sandy Hook and took possession of Harper's Ferry. The object of this movement upon Harper's Ferry was to cover the reconstruction of the Baltimore and Ohio railroad, and at the same time to draw the attention of the Confederates to their left flank, which was threatened by the movement. The operations of crossing the Potomac and the occupation of Harper's Ferry and Charlestown were superintended by Gen. McClellan in person. The bridges were thrown over the Potomac by Capt. J. C. Duane, U. S. engineers, on the 26th of February, and on the same day Gen. Banks occupied Harper's Ferry permanently, and the advance took possession of Bolivar Heights. On the 27th reconnoissances were pushed forward to Charles-

town, and some prisoners taken; Loudon Heights were also occupied. On the 28th of February Charlestown was occupied by a strong force with the intention of holding it against any attack. On the 3d of March Martinsburg was occupied by the 13th Massachusetts, who left camp at Williamsport on the previous afternoon. This is an important town on the Baltimore and Ohio railroad between Harper's Ferry and Hancock. It is distant from the former fifteen miles, and is twenty miles north of Winchester, with which it is connected by a turnpike road. All the iron of the double track of the railroad had been removed excepting half a mile of track made of compound rails. On the 2d, Leesburg was occupied by Col. Geary. The retreat of the Confederate army had now commenced along its entire line from Aquia Creek to the Shenandoah. This movement threatening its left flank was undoubtedly the cause of this abandonment of Manassas. All their important positions were occupied by the Federal troops during the next ten days, including the strong one at Centreville. Winchester was evacuated by Gen. Jackson on the night of the 11th of March. Gen. Shields, in command of Gen. Lander's division, soon followed up this retreat, and on the 19th he discovered Gen. Jackson reënforced in a strong position near New Market, and within supporting distance of the main body of the Confederate army under Gen. Johnston. In order to draw him from this position Gen. Shields fell back rapidly to Winchester on the 20th, as if in retreat, having marched his whole command thirty miles in one day. On the next day the Confederate cavalry under Gen. Ashby showed themselves in sight of Winchester. On the 22d the entire command of Gen. Banks, with the exception of Gen. Shields's division, evacuated Winchester and marched for Centreville. This movement, and the masked position in which Gen. Shields placed his division, led the enemy to believe that the town was evacuated with the exception of a few regiments to garrison it. That afternoon at 5 o'clock Gen. Ashby attacked the pickets of Gen. Shields and drove them in, but was repulsed by a small force pushed forward by Gen. Shields for that purpose, who now made preparations for a contest in the morning. Only a small Confederate force appearing in the morning, Gen. Shields ordered a portion of his artillery forward to open fire and unmask it. This had the desired effect, when a battle ensued, during which Gen. Shields by an attack upon the Confederate left flank forced that wing back upon its centre and placed the enemy in a position to be routed by a general attack, which was made at five o'clock in the afternoon with great success. The Confederates were driven from the field. Two guns, four caissons, three hundred prisoners, and a thousand stand of small arms were captured. The force of Gen. Shields was between seven and eight thousand men. His loss in killed and wounded was be-

tween three and four hundred. On the previous evening the arm of Gen. Shields was broken above the elbow by the fragment of a shell. The Confederate loss in killed and wounded was large. Considerable numbers were subsequently found in the houses of the inhabitants as the force of Gen. Banks advanced. The Confederate force was estimated at near ten thousand men. The brigades of Gens. Jackson, Smith, Garnett, and Longstreet were engaged, and prisoners were taken from the 2d, 4th, 5th, 21st, 28d, 27th, 28th, 88d, 87th, and 42d Virginia; 1st regiment of the Provisional Army, and an Irish battalion. For these movements Gen. Shields was complimented by the War Department in the following despatch:

WAR DEPARTMENT, March 26, 1862.

To Brig.-Gen. Shields:

Your two despatches relative to the brilliant achievement of the forces under your command have been received. While rejoicing at the success of your gallant troops, deep commiseration and sympathy are felt for those who have been victims in the gallant and victorious contest with treason and rebellion.

Your efforts as well as your success proves that Lander's brave division is still bravely led, and that wherever its standard is displayed rebels will be routed and pursued. To you and to the officers and soldiers under your command the Department returns thanks. EDWIN M. STANTON, Secretary of War.

The following was also received by Gen. Shields:

HEADQUARTERS ARMY OF THE POTOMAC, }  
SEMINARY, March 27, 1862. }

To Brig.-Gen. Shields:

The Commanding General congratulates you and the troops under your command upon the victory gained by your energy and activity and their bravery on the 28d. He is pained to learn that the wound you have received in the skirmish on the day before is more serious than at first supposed.

By command of

Maj.-Gen. GEO. B. McCLELLAN.  
S. WILLIAMS, Assist. Adj.-Gen.

The following congratulations and instructions were sent to Gen. Banks:

FAIRFAX SEMINARY, March 27, 1862.

To Maj.-Gen. Banks:

The General Commanding congratulates you and the brave troops under your command on the splendid achievement commenced in your department, news of which he has just received. He desires you to follow up rapidly the enemy's troops as far as Strasburg if possible. S. WILLIAMS, Assistant Adjutant-General.

This little affair at Winchester is said to have caused orders to be issued which were attended with momentous consequences. They will be stated hereafter. It occurred on the date of March 28d.

The evacuation by the Confederate army of their positions before Washington was conducted in a most successful manner. When the Union troops entered their intrenchments, all were gone. Their evacuation had been effected by means of the railroad from Manassas to Gordonsville, while the state of the roads was such as to prevent an immediate active campaign by the Union army. Their retreat was arrested at the Rappahannock river, and a new line formed for the purpose of defence. It stretch-

ed from the Rappahannock by a circle to Cumberland Gap near the extreme southwestern part of the State, embracing the Central and the Virginia and Tennessee railroads, the chief cities of Virginia, and the valley of the James river with its canal and railroads. It was simply a line of defence, and assumed as a necessity in view of the immense Federal force that had been marshalled and put quietly in position.

The design of Gen. McClellan, as above stated, was, so far as he was master of his own movements, to attack Richmond by the water line, on the ground that such a movement would certainly force the Confederate army out of Manassas. By the James river, Richmond could be approached by transports and gunboats of light draft, and without a long line for the transportation of supplies. At this time the President as commander-in-chief issued the following order:

EXECUTIVE MANSION, }  
WASHINGTON, March 8, 1862. }  
*General War Order, No. 2.*

*Ordered, I.* That the Major-General commanding the Army of the Potomac proceed forthwith to organize that part of said army destined to enter upon active operations (including the reserve, but excluding the troops to be left in the fortifications about Washington), into four army corps, to be commanded according to seniority of rank, as follows:

First Corps, to consist of three divisions, and to be commanded by Maj.-Gen. I. McDowell.

Second Corps, to consist of three divisions, and to be commanded by Brig.-Gen. E. V. Sumner.

Third Corps, to consist of three divisions, and to be commanded by Brig.-Gen. S. P. Heintzelman.

Fourth Corps, to consist of three divisions, and to be commanded by Brig.-Gen. E. L. Keyes.

II. That the divisions now commanded by the officers above assigned to the commands of corps, shall be embraced in and form part of their respective corps.

III. The forces left for the defence of Washington will be placed in command of Brig.-Gen. James Wadsworth, who shall also be Military Governor of the District of Columbia.

IV. That this order be executed with such promptness and despatch, as not to delay the commencement of the operations already directed to be undertaken by the Army of the Potomac.

V. A fifth army corps, to be commanded by Maj.-Gen. N. P. Banks, will be formed from his own and Gen. Shields's (late Gen. Lander's) division.

ABRAHAM LINCOLN.

In compliance with this order of the President, Gen. McClellan, on the 13th, issued an order dividing "the active portion of the army of the Potomac" into army corps as follows:

The corps of Gen. McDowell was composed of the divisions of Gens. Franklin, McCall, and King.

The corps of Gen. Sumner was composed of the divisions of Gens. Richardson, Blenker, and Sedgwick.

The corps of Gen. Heintzelman was composed of the divisions of Gens. Kearney, Hooker, and Fitz John Porter.

The corps of Gen. Keyes was composed of the divisions of Gens. Couch, Smith, and Casey.

The corps of Gen. Banks was composed of the divisions of Gens. Williams and Shields.

On the 11th of March, the President issued another order relieving Gen. McClellan from the command of all the military departments except that of the Potomac, and re-arranging the departments as follows:

EXECUTIVE MANSION, }  
WASHINGTON, March 11, 1862. }  
*General War Order, No. 3.*

Maj.-Gen. McClellan having personally taken the field at the head of the Army of the Potomac until otherwise ordered, he is relieved from the command of the other military departments, he retaining command of the Department of the Potomac.

*Ordered, further,* That the two departments now under the respective commands of Gens. Halleck and Hunter, together with so much of that under Gen. Buell as lies west of a north and south line indefinitely drawn through Knoxville, Tenn., be consolidated and designated the Department of the Mississippi, and that until otherwise ordered, Maj.-Gen. Halleck have command of said department.

*Ordered, also,* That the country west of the Department of the Potomac and east of the Department of the Mississippi be a military department, to be called the Mountain Department, and that the same be commanded by Maj.-Gen. Fremont.

That all the Commanders of Departments, after the receipt of this order by them respectively, report severally and directly to the Secretary of War, and that prompt, full, and frequent reports will be expected of all and each of them. ABRAHAM LINCOLN.

The effect of this order was to put under the charge of the Secretary of War a class of duties which had heretofore been under the direction of the highest military command. It relieved Gen. McClellan from the supervision of military operations in any other department than his own. He retained still under his immediate command the five corps of the army of the Potomac, as is manifest by his despatches, dated March 27, to Gens. Banks and Shields, after the battle at Winchester. It also shows that the corps of Gen. Banks was at that date expected to operate under his command, although he had then embarked a portion of his army to Fortress Monroe.

Assuming the distinct command of the Army of the Potomac, as his forces were now designated, for the purpose of conducting a campaign, Gen. McClellan issued the following address to his soldiers:

HEADQUARTERS ARMY OF THE POTOMAC, }  
FAIRFAX COURT HOUSE, VA., March 14, 1862. }

*Soldiers of the Army of the Potomac:*

For a long time I have kept you inactive, but not without a purpose. You were to be disciplined, armed, and instructed; the formidable artillery you now have, had to be created; other armies were to move and to accomplish certain results. I have held you back that you might give the death blow to the rebellion that has distracted our once happy country. The patience you have shown, and your confidence in your General, are worth a dozen victories. These preliminary results are now accomplished. I feel that the patient labors of many months have produced their fruit; the Army of the Potomac is now a real army—magnificent in material, admirable in discipline and instruction, excellently equipped and armed—your commanders are all that I could wish. The moment for action has arrived, and I know that I can trust in you to save our country. As I ride through your ranks, I see in your faces the sure presage of victory; I feel that you will do whatever I ask of you. The period of inaction has passed.

I will bring you now face to face with the rebels, and only pray that God may defend the right. In whatever direction you may move, however strange my actions may appear to you, ever bear in mind that my fate is linked with yours, and that all I do is to bring you, where I know you wish to be—on the decisive battle field. It is my business to place you there. I am to watch over you as a parent over his children; and you know that your General loves you from the depths of his heart. It shall be my care, as it has ever been, to gain success with the least possible loss; but I know that, if it is necessary, you will willingly follow me to our graves, for our righteous cause. God smiles upon us, victory attends us; yet I would not have you think that our aim is to be attained without a manly struggle. I will not disguise it from you: you have brave foes to encounter, foemen well worthy of the steel that you will use so well. I shall demand of you great, heroic exertions, rapid and long marches, desperate combats, privations, perhaps. We will share all these together; and when this sad war is over we will return to our homes, and feel that we can ask no higher honor than the proud consciousness that we belonged to the Army of the Potomac.

GEO. B. McCLELLAN,  
Major-General Commanding.

The Prince de Joinville, in a narrative of the campaign on the peninsula, has described with much detail the reasons for the evacuation of Manassas by the Confederate forces, and the change of the plan for the campaign under Gen McClellan. He states as follows:

"While we were riding forward, grave events were occurring in the highest regions of the army. There exists in the American army, as in the English, a commander-in-chief, who exercises over the head of all the generals a supreme authority, regulates the distribution of the troops, and directs military operations. These functions, which have been greatly curtailed in the British army since the Crimean war, were still exercised in all their vigor in America. From the aged General Scott, who had long honorably discharged them, they had passed to General McClellan. We learned, on reaching Fairfax, that they had been taken away from him. It is easy to understand the diminution of force and the restrictions upon his usefulness thus inflicted upon the general-in-chief by a blow in the rear at the very outset of his campaign.

"Yet this was but a part of the mischief done him. McClellan had long known, better than anybody else, the real strength of the rebels at Manassas and Centreville. He was perfectly familiar with the existence of the 'wooden cannon' by which it has been pretended that he was kept in awe for six months. But he also knew that till the month of April the roads of Virginia are in such a state that wagons and artillery can only be moved over them by constructing plank roads—a tedious operation, during which the enemy, holding the railways, could either retreat, as he was then actually doing, or move for a blow upon some other point. In any event, had McClellan attacked and carried Centreville, pursuit was impossible, and victory would have been barren of results. A single bridge burned would have saved Johnston's whole army. Such are the vast advantages of a railway for a retreating army—advantages

which do not exist for the army which pursues it.

"We have the right, we think, to say that McClellan never intended to advance upon Centreville. His long-determined purpose was to make Washington safe by means of a strong garrison, and then to use the great navigable waters and immense naval resources of the North to transport the army by sea to a point near Richmond. For weeks, perhaps for months, this plan had been secretly maturing. Secrecy as well as promptness, it will be understood, was indispensable here to success. To keep the secret it had been necessary to confide it to few persons, and hence had arisen the long ill feeling toward the uncommunicative general.

"Be this as it may, as the day of action drew near, those who suspected the general's project, and were angry at not being informed of it; those whom his promotion had excited to envy; his political enemies (who is without them in America?); in short, all those beneath or beside him who wished him ill, broke out into a chorus of accusations of slowness, inaction, incapacity. McClellan, with a patriotic courage which I have always admired, disclaimed these accusations, and made no reply. He satisfied himself with pursuing his preparations in laborious silence. But the moment came in which, notwithstanding the loyal support given him by the President, that functionary could no longer resist the tempest. A council of war of all the divisional generals was held; a plan of campaign, not that of McClellan, was proposed and discussed. McClellan was then forced to explain his projects, and the next day they were known to the enemy. Informed no doubt by one of those female spies who keep up his communications into the domestic circles of the Federal enemy, Johnston evacuated Manassas at once. This was a skilful manœuvre. Incapable of assuming the offensive, threatened with attack either at Centreville, where defence would be useless if successful, or at Richmond, the loss of which would be a great check, and unable to cover both positions at once, Johnston threw his whole force before the latter of the two.

"For the Army of the Potomac this was a misfortune. Its movement was unmasked before it had been made. Part of its transports were still frozen up in the Hudson. Such being the state of affairs, was it proper to execute as rapidly as possible the movement upon Richmond by water, or to march upon Richmond by land? Such was the grave question to be settled by the young general in a miserable room of an abandoned house at Fairfax within twenty-four hours. And it was at this moment that the news of his removal as general-in-chief reached him; the news, that is, that he could no longer count upon the cooperation of the other armies of the Union, and that the troops under his own orders were to be divided into four grand *corps* under four separate chiefs named in order of rank—a change which would throw into subaltern positions some young gen-

erals of division who had his personal confidence. It is easy to see that here was matter enough to cast a cloud upon the firmest mind. But the general's resolution was promptly taken.

"To follow the Confederates by land to Richmond at this season of the year was a material impossibility. An incident had just proved this to be so. Gen. Stoneman, with a flying column, had been sent in pursuit of the enemy. This column came up with the enemy on the Rappahannock, along the railway to Gordonsville, and had two engagements with him of no great importance. Then came the rain. The fords were swollen, the bridges carried away, the watercourses could no longer be passed by swimming; they were torrents. Stoneman's column began to suffer for want of provisions, and its situation was perilous. In order to communicate with the army, Stoneman had to send two of McClellan's aides-de-camp, who had accompanied him, across a river on a raft of logs tied together with ropes.

"Such was the country before the army. Furthermore, the enemy was burning and breaking up all the bridges. Now with the wants of the American soldier and the usual extravagance of his rations, and with the necessity of transporting everything through a country where nothing is to be found, and where the least storm makes the roads impassable, no army can live unless it supports its march upon a navigable watercourse or a railway. In Europe our military administration assumes that the transportation service of an army of one hundred thousand men can only provision that army for a three days' march from its base of operations. In America this limit must be reduced to a single day. I need only add that upon the roads to Richmond there were viaducts which it would have required six weeks to reconstruct.

"The land march was therefore abandoned, and we came back to the movement by water. But this operation also was no longer what it had been when McClellan had conceived it. The revelation of his plans to the enemy had allowed the latter to take his precautions. The evacuation of Manassas had preceded instead of following the opening of the Federal campaign. The movement by water could no longer be a surprise. Unfortunately it was also to lose the advantages of a rapid execution."

The movement of troops had been as follows: The last detachment of the Confederate army left Manassas on the 9th of March. On the morning of the 10th Gen. McClellan moved the Army of the Potomac toward the deserted position. The object of moving to Manassas was to verify its evacuation, to take the chance of cutting off the enemy's rear guard, to deceive the enemy, if possible, as to the real intentions of Gen. McClellan, and to gain the opportunity of cutting loose from all useless baggage, and to give the troops a few days' experience in bivouac and on the march. After reaching Manassas, Gen. McClellan returned to Washington on the 18th, and the army at once counter-

marched, and on Sunday the 16th it was massed in new positions near Alexandria, ready to embark with the least possible delay. During the ensuing week it began to embark on transports at Alexandria for Fortress Monroe. The number of transports promised was to be sufficient to convey fifty thousand men, but the number collected was found to be hardly enough for the conveyance of half that number. Instead of moving the whole army with its equipage at once, as it had been intended, a number of trips were required. The embarkation commenced on the 17th of March.

By reference to the order of the President issued on the 8th of March (*see* p. 84), it will be seen that the army was divided into five corps. Of these, the corps of Gens. Banks and McDowell did not embark. Of the second corps, under Gen. Sumner, one division, that of Gen. Blenker, was withdrawn and sent to Gen. Fremont in the Mountain Department. There remained therefore to be embarked, two divisions under Gen. Sumner, three under Gen. Heintzelman, and three under Gen. Keyes—being in all eight divisions. The Prince de Joinville, in his statement of the numbers of the entire army, says it consisted of "11 divisions of infantry, 8,000 to 10,000 strong; 1 division of regulars (infantry and cavalry), 6,000 strong; 350 pieces of artillery. The total effective force may have been 120,000 men." From this number are to be deducted the corps of Gen. McDowell and the division of Gen. Blenker. This will make the effective force of Gen. McClellan embarked for Fortress Monroe about eighty-five thousand men. Two weeks were occupied in transporting this force to Fortress Monroe.

It has been stated that Gen. Blenker's division was withdrawn from Gen. Sumner's corps, and sent to Gen. Fremont in the Mountain Department. This was done one or two days before Gen. McClellan sailed. The reason given was "political pressure" exercised to get a command for Gen. Fremont. No military reason was stated for this withdrawal. The following letter from President Lincoln to Gen. McClellan, produced at a court martial in Washington, thus explains it:

WASHINGTON, April 9, 1862.

*Maj.-Gen. McClellan:*

MY DEAR SIR: Your despatches complaining that you are not properly sustained, while they do not offend me, do pain me very much.

Blenker's division was withdrawn from you before you left here, and you know the pressure under which I did it; and, as I thought, acquiesced in it—certainly not without reluctance.

After you left I ascertained that less than twenty thousand unorganized men, without a single field battery, were all you designed to be left for the defence of Washington and Manassas Junction; and part of of this even was to go to Gen. Hooker's old position.

Gen. Banks's corps, once designed for Manassas Junction, was diverted and tied up on the line of Winchester and Strasburg, and could not leave it without again exposing the Upper Potomac and the Baltimore and Ohio railroad. This presented (or would present, when McDowell and Sumner should be gone) a great

temptation to the enemy to turn back from the Rappahannock and sack Washington.

My explicit order that Washington should, by the judgment of all the commanders of corps, be left entirely secure, had been neglected. It was precisely this that drove me to detain McDowell. I do not forget that I was satisfied with your arrangement to leave Banks at Manassas Junction; but when that arrangement was broken up, and nothing was substituted for it, of course I was not satisfied; I was constrained to substitute something for it myself.

And now allow me to ask, "Do you really think I should permit the line from Richmond, *via* Manassas Junction, to this city, to be entirely open, except what resistance could be presented by less than twenty thousand unorganized troops?" This is a question which the country will not allow me to evade.

There is a curious mystery about the number of troops now with you. When I telegraphed you on the 6th, saying that you had over one hundred thousand with you, I had just obtained from the Secretary of War a statement taken, as he said, from your own returns, making one hundred and eight thousand then with you, and *en route* to you.

You now say you will have but eighty-five thousand when all *en route* to you shall have reached you. How can the discrepancy of twenty-three thousand be accounted for?

As to Gen. Wool's command, I understand it is doing for you precisely what a like number of your own would have to do, if that command was away.

I suppose the whole force which has gone forward for you is with you by this time; and, if so, I think it is the precise time for you to strike a blow. By delay the enemy will relatively gain upon you; that is, he will gain faster by fortifications and reinforcements than you can by reinforcements alone.

And, once more, let me tell you it is indispensable to you that you strike a blow. I am powerless to help this. You will do me the justice to remember I always insisted that going down the bay in search of a field, instead of fighting at or near Manassas, was only shifting and not surmounting a difficulty; that we would find the same enemy and the same or equal intrenchments at either place. The country will not fail to note—is now noting—that the present hesitation to move upon an intrenched enemy is but the story of Manassas repeated.

I beg to assure you that I have never written you or spoken to you in greater kindness of feeling than now, nor with a fuller purpose to sustain you so far as in my most anxious judgment I consistently can. But you must act.

Yours, very truly,

A. LINCOLN.

When Gen. McClellan sailed he supposed that Gen. McDowell's corps would follow him, and it was not until he was before Yorktown that he received the first intimation to the contrary. The reason of this change should also be stated.

By reference to a preceding page, it will be seen that the battle of Winchester took place on the 23d of March, about the time the army of the Potomac was embarking. It startled the Government by revealing a much stronger force of the enemy in their immediate front than they had supposed. At the same time the number of troops at Washington being limited, it was decided that one of the two corps which had not embarked (either McDowell's or Sumner's) should be withheld, and the decision fell upon Gen. McDowell. The same question came up in Congress on the 26th of May, after Gen. Jackson had made his brilliant dash up the Shenandoah, and driven Gen. Banks across the Potomac. Al-

though it may be anticipating some events, it is proper that the explanation of the withdrawal of McDowell's corps should be here noticed. In the Senate, Mr. Wilson of Massachusetts, chairman of the Committee on Military Affairs, said: "I will state that the Secretary of War is not responsible for the movements charged upon him by the Senator from Kentucky. The President alone is responsible for whatever has occurred, both for arresting the advance of General McDowell to Yorktown, and withdrawing a portion of Gen. Banks's forces. The order arresting the advance of Gen. McDowell was made by the President, with the approval of the Secretary of War, General Hitchcock, and several other military men. It was given for the best of purposes, and I am sure there was no intrigue about it, nor personal objects gained. It may have been an error; but, if so, it was an error committed by the President for an honest and patriotic purpose, under the advice of the military men whom he consulted. I understand the fact to be that the President gave written orders—in fact I have seen the orders—that the number of men necessary for the defence of Washington should be left here, and that that number should be agreed upon by the commanders of the various corps of the army. The commanders of corps held a consultation, and decided that forty-five thousand men were necessary to be held for the defence of this city. All the forces were ordered to be withdrawn from this city, with the exception of nineteen thousand, and four thousand of that number were sent for. Nearly all of the regiments left here were recently brought into the service, and four or five of them were cavalry regiments, not mounted, and not in a condition for service. Under these circumstances, apprehending precisely what has taken place, the President withheld thirty thousand men under Gen. McDowell. Ten thousand of this force, under Gen. Franklin, at the urgent request of Gen. McClellan, were sent forward to Yorktown, but McDowell was held back with twenty thousand men on the Rappahannock to protect the capital and menace Richmond. The President then, in order to concentrate a force here and threaten Richmond, and aid Gen. McClellan's movements, ordered Gen. Shields to unite with Gen. McDowell, thus making an army of about forty thousand men, the intention of which was to move on Richmond by land, so as to cover Washington in their movement. This left Gen. Banks a small force, and a movement has been made upon him, and he has been compelled to evacuate the Shenandoah Valley and recross the Potomac. These movements were directed by the President; and he is alone responsible for them. In doing what he did, I have no doubt he was actuated by honest purposes, and he had the sanction and support of his military advisers, including the Secretary of War."

Mr. Trumbull of Illinois said: "While the Senator from Massachusetts is making his state-

ment, I should like to inquire of him if it was not at the urgent and repeated request of Gen. McClellan that troops should be sent to him to aid in his attack upon Richmond that this has been done?"

Mr. Wilson of Massachusetts: "In response to the Senator's question, I will say that I understand that Gen. McClellan desired to have the forces reserved under Gen. McDowell sent forward to him by the steamers. Upon his request, Gen. Franklin with his division was sent forward to Yorktown. The President, to protect Washington, and at the same time to aid Gen. McClellan by menacing Richmond, withdrew Gen. Shields's division from Gen. Banks, thus concentrating on the Rappahannock forty thousand men. This force could move on Richmond, or act directly for the protection of Washington, according to circumstances. Yesterday the President, in view of what has occurred, stated that this force of twenty thousand men, which he had reserved, and for which he takes the entire responsibility, had been reserved by him in apprehension of precisely such a movement of the enemy threatening this city as has already taken place.

"The President may have made a mistake in withdrawing so much of the force of Gen. Banks, but I am sure he acted according to the best lights he possessed. Gen. Banks has been forced to retrace his steps, to abandon the Shenandoah Valley, and to recross the Potomac."

On Dec. 10, before a court martial at Washington, Gen. McClellan, in answer to the question, What communication he received from the President through Gen. Franklin, &c. said: "The substance of the communication of Gen. Franklin from the President was that the President assumed the responsibility of the change of destination of Gen. McDowell's corps, regarding that corps necessary for the defence of Washington, although the troops actually left in Washington and in front of it, disposable for its defence, were rather more than double the garrison fixed by the engineer and artillery officers, and considerably more than the largest number recommended by any of the corps commanders to be left in the vicinity of Washington."

The following orders of Gen. McClellan will show his plans for the protection of Washington:

HEADQUARTERS, ARMY OF THE POTOMAC, }  
March 16, 1862.

*Brig.-Gen. James S. Wadsworth, Military Governor of the District of Columbia:*

SIR: The command to which you have been assigned, by instruction of the President, as Military Governor of the District of Columbia, embraces the geographical limits of the district, and will also include the city of Alexandria, the defensive works south of the Potomac, from the Occoquan to Difficult Creek, and the post of Fort Washington. I enclose a list of the works and defences embraced in these limits. Gen. Banks will command at Manassas Junction, with the divisions of Williams and Shields, composing the Fifth Army Corps, but you should, nevertheless, exercise vigilance in your front, carefully guard the approaches in that quarter, and maintain the duties of advanced guards. You will use the same precautions on either

flank. All troops not actually needed for the police of Washington and Georgetown, for the garrisons north of the Potomac, and for other indicated special duties, should be removed to the south side of the river. In the centre of your front you should post the main body of your troops, in proper proportions, at suitable distances toward your right and left flanks. Careful patrols will be made to thoroughly scour the country in front from right to left.

It is specially enjoined upon you to maintain the forts and their armaments in the best possible order, to look carefully after the instruction and discipline of their garrisons, as well as all other troops under your command, and by frequent and rigid inspection to insure the attainment of these ends.

The care of the railways, canals, depots, bridges, and ferries within the above-named limits will devolve upon you, and you are to insure their security and provide for their protection by every means in your power. You will also protect the depots of the public stores and the transit of the stores to the troops in actual service.

By means of patrols you will thoroughly scour the neighboring country south of the eastern branch, and also on your right, and you will use every possible precaution to intercept mails, goods, and persons passing unauthorized to the enemy's lines.

The necessity of maintaining good order within your limits, and especially in the capital of the nation, cannot be too strongly enforced. You will forward and facilitate the movement of all troops destined for the active part of the Army of the Potomac, and especially the transits of detachments to their proper regiments and corps.

The charge of all new troops arriving in Washington, and of all troops temporarily there, will devolve upon you. You will form them into provisional brigades, promote their instruction and discipline, and facilitate their equipments. Report all arrivals of troops, their strength, composition, and equipment, by every opportunity. Besides the regular reports and returns which you will be required to render to the Adjutant-General of the army, you will make to these headquarters a consolidated morning report of your command every Sunday morning, and a monthly return on the first day of each month.

The foregoing instructions are communicated by command of Maj.-Gen. McClellan.

Very respectfully, your obedient servant,

Assistant Adjutant-General.

HEADQUARTERS, ARMY OF THE POTOMAC, }  
March 16, 1862.

To Maj.-Gen. N. P. Banks, Commanding Fifth Corps, Army of the Potomac:

SIR: You will post your command in the vicinity of Manassas, intrench yourself strongly, and throw cavalry pickets well out to the front. Your first care will be the rebuilding of the railway from Washington to Manassas and to Strasburg, in order to open your communications with the valley of the Shenandoah. As soon as the Manassas Gap railway is in running order, intrench a brigade of infantry—say four regiments, with two batteries—at or near the point where that railway crosses the Shenandoah. Something like two regiments of cavalry should be left in that vicinity to occupy Winchester, and thoroughly scour the country south of the railway and up the Shenandoah Valley, as well as through Chester Gap, which might perhaps be occupied advantageously by a detachment of infantry well intrenched. Block houses should be built at all the railway bridges occupied by grand guard, Warrenton Junction or Warrenton itself, and also some still more advanced points on the Orange and Alexandria railroad, as soon as the railroad bridges are repaired.

Great activity should be observed by the cavalry. Besides the two regiments at Manassas, another regiment of cavalry will be at your disposal to scout toward the Occoquan, and probably a fourth toward

Leesburg. To recapitulate, the most important points that should engage your attention are as follows:

*First*—A strong force, well entrenched, in the vicinity of Manassas, perhaps even Centreville, and another force, a brigade, also well entrenched near Strasburg.

*Second*—Block houses at the railroad bridges.

*Third*—Constant employment of cavalry well to the front.

*Fourth*—Grand guards at Warrenton, and in advance as far as the Rappahannock, if possible.

*Fifth*—Great care to be exercised to obtain full and early information as to the enemy.

*Sixth*—The general object is to cover the line of the Potomac and Washington.

The foregoing is communicated by order of Maj.-Gen. McClellan.

Assistant Adjutant-General.

On the 1st of April Gen. McClellan addressed the following additional note to Gen. Banks:

HEADQUARTERS, ARMY OF THE POTOMAC, }  
ON BOARD COMMODORE, April 1, 1862. }

Maj.-Gen. N. P. Banks, Commanding Fifth Army Corps:

GENERAL: The change in affairs in the valley of the Shenandoah has rendered necessary a corresponding departure, temporarily at least, from the plan we some days since agreed upon.

In my arrangements I assume that you have a force amply sufficient to drive Jackson before you, provided he is not reinforced largely. I also assume that you may find it impossible to find anything toward Manassas for some days, probably not until the operations of the main army have drawn all the rebel force toward Richmond.

You are aware that Gen. Sumner has for some days been at Warrenton Junction, with two divisions of infantry, six batteries, and two regiments of cavalry, and that a reconnaissance to the Rappahannock forced the enemy to destroy the railroad bridge at Rappahannock Station, on the Orange and Alexandria railroad. Since that time our cavalry have found nothing on this side of the Rappahannock in that direction, and it seems clear that we have no reason to fear any return of the rebels in that quarter. Their movements near Fredericksburg also indicate a final abandonment of that neighborhood.

I doubt whether Johnston will now reinforce Jackson with a view to offensive operations. The time has probably passed when he could have gained anything by so doing.

I have ordered one of Sumner's divisions (that of Richardson) to Alexandria for embarkation. Blenker's has been detached from the Army of the Potomac, and ordered to report to Gen. Fremont. Abercrombie is probably at Warrenton Junction to-day; Geary at White Plains.

Two regiments of cavalry have been ordered out, and are now on the way to relieve the two regiments of Sumner. Four thousand infantry and one battery leave Washington at once for Manassas. Some three thousand more will move in one or two days, and soon after three thousand additional.

I will order Blenker to move on Strasburg and report to you for temporary duty; so that, should you find a large force in your front, you can avail yourself of his aid. As soon as possible, please direct him on Winchester, thence to report to the Adjutant-General of the Army for orders; but keep him until you are sure what you have in front.

In regard to your own movements, the most important thing is to throw Jackson well back, and then to assume such a position as to enable you to prevent his return. As soon as the railway communications are re-established, it will be probably important and advisable to move on Staunton; but this would require communications and a force of 25,000 to 30,000 for active operations. It should also be nearly coincident with my own move on Richmond. At all events,

not so long before it as to enable the rebels to concentrate on you and then return to me.

I fear that you cannot be ready in time; although it may come in very well with a force less than I have mentioned, after the main battle near Richmond. When Gen. Sumner leaves Warrenton Junction, Gen. Abercrombie will be placed in immediate command of Manassas and Warrenton Junction, under your general orders. Please inform me frequently by telegraph and otherwise as to the state of things in your front. I am, very truly yours,

GEO. B. McCLELLAN,  
Maj.-Gen. Commanding.

P. S. From what I have just learned, it would seem that the two regiments of cavalry intended for Warrenton Junction have gone to Harper's Ferry. Of the four additional regiments placed under your orders, two should as promptly as possible move by the shortest route on Warrenton Junction.

I am, sir, very respectfully, your obedient servant,  
GEO. B. McCLELLAN,  
Maj.-Gen. Commanding.

HEADQUARTERS, ARMY OF THE POTOMAC, }  
STEAMER COMMODORE, April 1, 1862. }

To Brig.-Gen. L. Thomas, Adj.-Gen. U. S. A.:

GENERAL: I have to request that you will lay the following communication before the Hon. Secretary of War. The approximate numbers and positions of the troops left near and in rear of the Potomac are about as follows:

Gen. Dix has, after guarding the railroads under his charge, sufficient troops to give him five thousand men for the defence of Baltimore, and one thousand nine hundred and eighty-eight available for the eastern shore, Annapolis, &c. Fort Delaware is very well garrisoned by about four hundred men. The garrisons of the forts around Washington amount to ten thousand men, other disposable troops now with Gen. Wadsworth being about eleven thousand four hundred men. The troops employed in guarding the various railroads in Maryland amount to some three thousand three hundred and fifty-nine men. These it is designed to relieve, being old regiments, by dismounted cavalry, and to send them forward to Manassas. Gen. Abercrombie occupies Warrenton with a force which, including Col. Geary's at White Plains, and the cavalry to be at their disposal, will amount to some seven thousand seven hundred and eighty men, with twelve pieces of artillery.

I have the honor to request that all the troops organized for service in Pennsylvania and New York and in any of the Eastern States, may be ordered to Washington. This force I should be glad to have sent at once to Manassas—four thousand men from Gen. Wadsworth to be ordered to Manassas. These troops, with the railroad guards above alluded to, will make up a force under the command of Gen. Abercrombie to something like eighteen thousand six hundred and thirty-nine men. It is my design to push Gen. Blenker from Warrenton upon Strasburg. He should remain at Strasburg long enough to allow matters to assume a definite form in that region before proceeding to his ultimate destination. The troops in the valley of the Shenandoah will thus—including Blenker's division, ten thousand and twenty-eight strong, with twenty-four pieces of artillery, Banks's Fifth Corps, which embraces the command of Gen. Shields, nineteen thousand six hundred and eighty-seven strong, with forty-one guns, some three thousand six hundred and fifty-three disposable cavalry, and the railroad guard, about twenty-one hundred men—amount to about thirty-five thousand four hundred and sixty-seven men.

It is designed to relieve Gen. Hooker by one regiment—say eight hundred and fifty men—being, with five hundred cavalry, thirteen hundred and fifty men on the Lower Potomac. To recapitulate: At Warrenton there are to be seven thousand seven hundred and eighty; at Manassas, say ten thousand eight hundred and fifty-nine; in the Shenandoah Valley, thirty-five thousand four hundred and sixty-seven; on the Lower



Potomac, thirteen hundred and fifty—in all, fifty-five thousand four hundred and fifty-six. There would then be left for the garrisons in front of Washington and under Gen. Wadsworth some eighteen thousand men, exclusive of the batteries, under instructions. The troops organizing or ready for service in New York, I learn, will probably number more than four thousand. These should be assembled at Washington, subject to disposition where their services may be most needed.

I am, very respectfully, your obedient servant,  
GEO. B. McCLELLAN,  
Maj.-Gen. Commanding.

Some explanation of these orders is to be found in answers of Gen. McClellan to interrogatories before the court martial above mentioned. In one answer he said: "The force left disposable for the defence of Washington was about 70,000 men, independent of the corps of Gen. McDowell." Again, he said: "My recollection of the suggestions as to the forces to be left varied from forty to fifty thousand. I think Gen. McDowell proposed the latter number. Of one thing I am confident: that, with the facts fresh in my mind, I thought that I left more than was suggested by any corps commander."

As to the necessity that Gen. McDowell should remain for the defence of Washington, he said: "I think that Gen. McDowell was correct in his opinion that it was safe and proper for him to unite with the Army of the Potomac. I think that immediately after the occupation of Hanover Court House by a portion of the Army of the Potomac, there was no rebel force of any consequence between Hanover Court House and Gen. McDowell. I think that the main object of Jackson's movement against Gen. Banks was to prevent reinforcements from being sent to the Army of the Potomac, and expressed that opinion in a telegram to the President within a day of the time I received information of Jackson's movements. I think that if Gen. McDowell had moved direct upon Hanover Court House, instead of in the direction of Front Royal, Jackson would have rapidly retraced his steps to join the main rebel army at Richmond. With a strong army of our own in the vicinity of Richmond, and threatening it, I do not think that the rebels would have detached a sufficient force to seriously endanger the safety of Washington."

Before Gen. McClellan left Washington, an order was issued placing Gen. Wool and all his troops under his command, and he was expressly authorized to detail a division of about 10,000 men from the troops under Gen. Wool and to attach them to the active army. After operations had commenced on the peninsula, on the 3d of April Gen. McClellan received an order from the Secretary of War countermanding all this. No explanation of this has ever been made.

The design of Gen. McClellan was to make a sure and rapid movement upon Richmond, but other causes still occurred to defeat this purpose. The contest between the Monitor and Merrimac took place on the 9th of March (*see* NAVAL

OPERATIONS), and the insecurity of the transports, while the navy really had not entire control of the James river, caused the troops to be landed at Fortress Monroe, and the march to be commenced overland from that point.

About the 1st of April the force above stated had reached Fortress Monroe, Gen. McClellan arrived on the 2d, and commenced active operations. On the 4th of April the following order was issued from the War Department:

WAR DEPARTMENT, WASHINGTON, April 4, 1862.

*Ordered, 1.*—That the portion of Virginia and Maryland lying between the Mountain Department and the Blue Ridge shall constitute a military department, to be called the Department of the Shenandoah, and be under the command of Maj.-Gen. Banks.

*2.*—That the portion of Virginia east of the Blue Ridge and west of the Potomac and the Fredericksburg and Richmond railroad, including the District of Columbia and the country between the Potomac and the Patuxent, shall be a military district, to be called the Department of the Rappahannock, and be under the command of Maj.-Gen. McDowell.

By order of the PRESIDENT.

EDWIN M. STANTON, Secretary of War.

The effect of this order was to take from under the control of Gen. McClellan the forces of Gens. Banks and McDowell, and the direction of all military operations in his department west of the Richmond and Fredericksburg railroad, and in lower Maryland, and to confine him strictly to the remainder of eastern Virginia. On the 11th of April, the following order was sent to Gen. McDowell:

WAR DEPARTMENT, April 11, 1862.

*Maj.-Gen. McDowell Commanding:*

SIR: For the present, and until further orders, you will consider the national capital as especially under your protection, and make no movement throwing your force out of position for the discharge of this primary duty.

EDWIN M. STANTON, Secretary of War.

On the 5th of April, firing was opened by the enemy at Yorktown on the extreme Federal right, to repel a bold reconnoissance. While this was going on, Gen. McClellan heard for the first time that Gen. McDowell was withdrawn from his command. Yorktown is a post village, port of entry, and shire town of York county, Virginia. It is situated on rising ground on the right bank or south side of York river, eleven miles from its mouth. It is seventy miles east-southeast of Richmond, and had before the war about sixty houses, four hundred and fifty inhabitants, and several thousand tons of shipping.

The army of the Potomac had commenced its march upon this place wholly in the dark as to the nature of the country, or the position and strength of the enemy. The maps which were furnished by the commanders at Fortress Monroe were found to be entirely erroneous. The peninsula is bounded on the north by York river, which is commanded by Yorktown and Gloucester, on either side. Both places were strongly fortified to obstruct the entrance of the river by gunboats. The Confederate batteries mounted fifty-six guns, many of which were

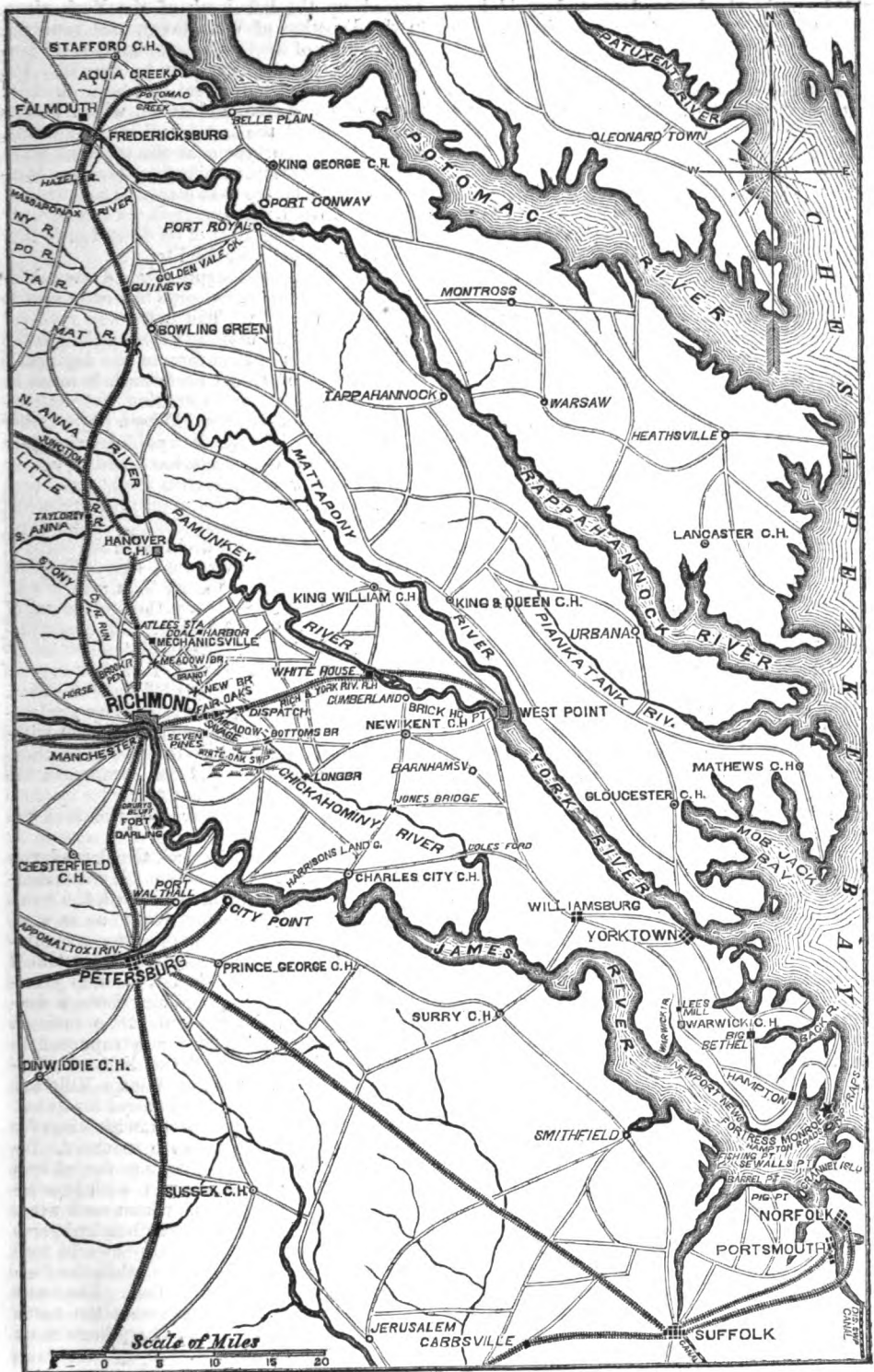

rifled one-hundred pounders, and could have sunk the entire fleet of these gunboats. The James river, which bounded the peninsula on the south, was in full possession of the enemy. The line of defence at Yorktown was selected with great judgment. Taking advantage of the highest ground on the peninsula at that place, and projecting a line of intrenchments and forts bearing a little southwest to a point connecting with the head of Warwick river, the enemy had continued his works down that stream to James river, making the entire distance from point to point eight and a half miles. While the flat and marshy surface of the peninsula, together with streams constantly fed with copious supplies of water from the swamps, afforded peculiar means of defence, it was equally unfavorable to offensive operations, especially when distant from the harbor for supplies and with bad roads. The country was also covered with dense forests of pine, which formed a valuable shield to the positions of the enemy.

From the 5th to the 8th, when the unfavorable weather suspended active hostilities on both sides, there were frequent skirmishes, and firing by artillery, to prevent the enemy from constructing further defences and mounting additional guns, with few casualties on either side. On the 8th, 9th, and 10th there was a succession of extraordinary storms of rain and hail with some sleet and snow. The enemy took advantage of this weather to complete their defences. Much work was done in the interval by the Federal army in making and corduroying roads to the depots, &c.

When the army left Fortress Monroe, Gen. Keyes with three divisions proceeded along the James river until he reached the Warwick. In seeking for a ford he discovered the Confederate line of defence. Dykes had been erected in different parts of this stream, converting it into a kind of pond. These dams were defended by redoubts, artillery, and rifle pits.

The supplies of the army consisted in provisions for two days, which each soldier had taken. After these two days the army was entirely dependent on the wagons for subsistence. It was therefore necessary to construct roads. These were made by cutting down trees of equal size, and from one foot to eighteen inches in diameter, and placing the pieces from twelve or eighteen feet in length, side by side, on the ground. All the infantry that were not on picket duty on the outposts, were employed up to their knees in mud and water in this labor. By this means the cannon and wagons arrived at places where otherwise it would have been impossible to have brought them.

In order to avoid the delays of a siege, Gen. McClellan had formed a plan to turn the position at Yorktown. This was to be done by effecting a landing on the Severn river, north and in the rear of Gloucester, by which this latter position might be carried, and thus render the York river less difficult of entrance by the gunboats. The Federal force could then have ad-

vanced up the left bank of the York river, in the direction of West Point, and rendered the position of the Confederate army most perilous, if they had persisted in holding it. The execution of this movement had been confided to the corps of Gen. McDowell, which was to have embarked the last of all, at Alexandria, and arrive at Yorktown at the moment when the rest of the army, coming from Fortress Monroe, appeared before that place. This corps of Gen. McDowell was detained, as has already been stated. The effect of its detention is thus stated by Prince De Joinville:

"We received the inexplicable and unexplained intelligence that this corps had been sent to another destination. The news was received by the army with dissatisfaction, although the majority could not then foresee the deplorable consequences of an act performed, it must be supposed, with no evil intention, but with inconceivable recklessness. Fifteen days earlier this measure, although it would always have been injurious, would not have had so bad an effect; for new arrangements might have been made. Now, it was the mainspring removed from a great work already begun. It deranged everything. Among the divisions of the corps of Gen. McDowell there was one—that of Franklin—which was regretted more than all the rest, both on account of the troops themselves and of the officers commanding them. The commander-in-chief had carefully superintended its organization during the winter. He held it in great esteem and earnestly demanded its restoration. It was sent back to him, without any explanation, in the same manner as it had been withdrawn. This splendid division—eleven thousand strong—arrived, and for a moment the commander thought of intrusting to it alone the storming of Gloucester; but the idea was abandoned."

The next step was to search the Confederate line of defence for weak points. It was believed that if any were found and forced, the result would be, that the enemy would, as is usual in such cases, believe that his position was turned at both extremities, and his forces would become demoralized. Then if he was vigorously pushed with overwhelming force, a serious, if not fatal disaster might be inflicted on his army. This point was supposed to exist about the centre of the line, on Warwick river or creek, below Winn's Mills and near Lee's Mills. Here the Federal forces had thrown up a considerable work, with wings for riflemen, in which guns were mounted. Directly opposite the enemy, were protected by a demi-lune with two embrasures, with long infantry epaulements extending from each wing. An open field some six or seven hundred yards in width intervened. The enemy's works rested on the skirts of a pine forest, while the Federal were in the centre of the field. The forest extended like a curtain clear across the north edge of the field, in which sharpshooters on either side were posted.

On the 16th four Federal batteries of light artillery, under Capts. Ayres, Mott, Kennedy, and Wheeler, opened furiously upon the opposite work, and soon drove the enemy's cannoners to shelter. Detachments consisting of companies E, F, D, and K, of a Vermont regiment, were ordered forward through the woods to capture the Confederate work. These brave men pushed forward firmly under a scattering fire of musketry, and were struggling through the creek, when the enemy, in superior force, opened upon them a galling fire of rifles and musketry. They still went forward unfalteringly, and their ranks were rapidly thinning, when they were recalled. Not more than half their number had crossed the stream. They reluctantly obeyed, but soon it became more difficult to return than it had been to advance. The enemy suddenly opened a sluice above, and almost overwhelmed them with a flow of water which reached their armpits. They maintained their order firmly, however, under cover of the batteries, which with the sharpshooters kept the enemy within their intrenchments, and in a short time extricated themselves, bringing away all their dead and wounded except six. The casualties exceeded one hundred and fifty. The attempt to force through the enemy's line was afterward abandoned, having presented unforeseen difficulties.

Sharpshooting was a feature of the early part of the campaign on the peninsula. An officer thus describes one or two scenes:

"The operations of our fellows were extremely interesting. One man was securely posted behind an embankment with a glass, and upon discovering an enemy, he signalized the active riflemen. The latter, covered by rifle pits or trees, were constantly blazing away, and at each successful shot would make some satisfactory sign. One of them afforded considerable amusement by his daring antics. Depositing his rifle every now and then behind a tree, he would dash across the field from his cover to our bastion and back again quickly, courting a shot, while his comrades watched for a victim. He must have made twenty trips while we observed him. Once or twice the enemy's balls knocked up the dust a few feet from him, and quicker than thought a leaden messenger would be sent after the unlucky enemy. We left the saucy fellow continuing his hazardous pranks."

The siege of Yorktown was now commenced in earnest. The Federal army was encamped before it in line of battle order. The arrangement of the columns, however, was influenced by the nature and topography of the position invested. It is thus summarily described by Prince de Joinville:

"The last operation, like that on Gloucester, not being accomplished, nothing remained but to begin a regular siege against Yorktown. All this wandering in the dark had, unfortunately, consumed much time, and the siege itself would consume much more, although it should be pushed with the greatest energy. Ten thou-

sand laborers were unceasingly employed cutting through the woods and forming roads, trenches, and batteries. It was a curious spectacle. A straight arm of the sea, fringed by a thick and strong vegetation, mixed with trees of all kinds, living and dead, entangled with withes and moss, approached in a serpentine form to the front of the attack. The first parallel was made. The wood which surrounded us was an admirable protection. This arm of the sea was covered with bridges. Roads were cut along its margin in the midst of tulips, flowers of Judea, and azaleas in full bloom. From this natural parallel others were formed by the hands of man, and we rapidly approached the place. The defenders opened a terrific fire on those works that they could see, as well as upon those which they supposed were in progress. Shells whistled on every side through the large trees, cutting down branches, frightening horses, but otherwise doing very little harm. Nobody cared about it. In the evening, when all the laborers returned in good order, with their rifles on their backs, and their shovels on their shoulders, the fire became more furious, as if the enemy had marked the hour of their return. We went to this cannonade as to a show; and when, on a beautiful night in spring time, the troops gayly marched along to this martial music through the flowering woods; when the balloon, with which we made our reconnoissances, was floating in the air, we seemed to be spectators at a fête, and for a moment were made to forget the miseries of war.

"The siege, however, still went on. Powerful artillery, with great difficulty, had been brought up; 100 and even 200-pounder rifled cannon, and 18-inch mortars were ready to batter the place: Fourteen batteries were constructed, armed, and appointed. If our fire had not been yet opened, it was because it was designed to open all our batteries together along the whole line; and for this reason we waited until nothing was wanting to complete all our preparations. We could not, however, resist the desire to try the 200-pounders. These enormous pieces were handled with incredible ease. Four men sufficed to load and aim them, without any more difficulty than in the working of our old 24-pounders. At a distance of three miles their fire was admirably precise. One day one of these immense pieces had a kind of duel with a rifled piece of somewhat smaller caliber, in position on the bastions at Yorktown. The curious among us mounted on the parapet to see where the missiles might fall, and, while they communicated their observations to one another, the sentry on the look-out would announce when the enemy was about to fire in turn; but the distance was so great that, between the discharge and the arrival of the projectile, everybody had time to descend without any hurry, and to place himself under the shelter of the parapet. Such, however, was the precision of the fire that we were sure to see the enormous projectile passing over the very

spot where the group of observers had been standing but a moment before; then it would bound along and tear up the earth some fifty or sixty yards off, and its inflammable composition would burst with a loud explosion, throwing into the air a cloud of dust as high as the water jets of St. Cloud.

"It was evident that with the powerful means at our disposal the capture of Yorktown was but a work of time. Shattered beneath the tremendous fire which was about to be opened upon it, without casemates to cover their soldiers, without any other defence than outworks and palisades, the place had not even the chance of opposing a lengthened resistance. Everything was ready for the final blow. Not only was a terrific bombardment about to be opened upon the town, not only were the most select troops set apart to follow up this bombardment by a grand assault, but the steam transports only awaited a sign to push immediately up the York river, and to land Franklin's troops at the upper part of the stream, on the line of retreat of the Confederate army. A part of these troops were also to remain on board the transports. They would have taken but a few hours to traverse by water the distance it would have taken the enemy's army two days at least to march by land. Driven from the lines of Yorktown by a powerful attack, pursued sword in hand, intercepted on the route by fresh troops, that army would have been in a most critical position, and the Federals would have obtained what they so much desired—an astonishing military success.

"A great success of the Federal army before Yorktown was therefore of vital importance to the Government at Washington. Unfortunately, the Confederate leaders and generals were of the same opinion, and, as able and resolute men, they took the best means to render it impossible."

On the nights of the 3d and 4th of May, Yorktown and the Confederate lines of the Warwick river were evacuated. This work, doubtless commenced several days before, and was conducted with great skill and energy. On the 3d the fire of the enemies batteries was redoubled in severity. This was done to mask their retreat, and it was highly successful. The absence of all signs of them on the morning of the 4th, caused their lines to be closely examined, when it was soon ascertained that they were abandoned. The capture of this strong position of Yorktown and its armament with scarcely any loss of life, was a brilliant military success.

The impossibility for the navy to coöperate with the army, the want of forces to turn the flank of the enemy, as had been originally planned, and their obstinate courage and efforts to prevent the capture of Yorktown, had caused the delay of a month before that place. During this time the defences of Richmond had been pushed forward, and the spring time of the year had so far passed away, that the hot

season was at hand, which would produce diseases in the low lands of the peninsula, and thus greatly aid the enemy. The loss thus far on the Federal side was about three hundred. That of the Confederates has not been ascertained. They left in their works at Yorktown two 8-inch rifled cannon, two 4½-inch rifled cannon, sixteen 32-pounders, six 42-pounders, nineteen 8-inch columbiads, four 9-inch Dahlgrens, one 10-inch columbiad, one 10-inch mortar, and one 8-inch siege howitzer, with carriages and implements complete. Each piece was supplied with 76 rounds of ammunition. At Gloucester there was captured nine 9-inch Dahlgrens, two 32-pounders rifled, five 32-pound navy guns, five 42-pound carronades; making at both places a total of seventy-three guns and much ammunition.

Their force has been estimated at 100,000 men. Some of the Federal soldiers were killed and horses injured by the explosion of instruments of destruction left by the enemy. It was at this time that New Orleans was captured.

The next important point before the Federal army was the city of Williamsburg. There were two roads to that city: one direct from Yorktown; and the other, from the left of the Federal army, crossed Warwick river at Lee's Mills, and uniting with the first formed a fork near Williamsburg.

This city is the capital of James City county, and is situated near the narrowest part of the peninsula between the James and York rivers, and is three miles from James river and about five and a quarter from York river. It is one of the oldest towns in the State, and contained a population of about fifteen hundred.

As soon as the evacuation of Yorktown was known, the entire cavalry and horse artillery with five divisions of infantry were advanced in pursuit. Gen. Franklin's division was ordered to move at once by water to the vicinity of West Point to endeavor to check the retreat of the enemy, and to be supported by other divisions as rapidly as water transportation could be obtained. The remaining divisions were massed near Yorktown, ready to move by land or water, as might be necessary. Gen. McClellan meanwhile remained at Yorktown until Monday noon, the 5th, pushing the movement of the troops to West Point by water and awaiting the development of events. It was not until that time that he was made aware of the serious resistance encountered at Williamsburg. All the information up to that time indicated nothing more than an affair of a rear guard. As soon as the true state of affairs was known he moved rapidly to the front and assumed the immediate command.

Gen. Stoneman had led the advance, with his cavalry and four batteries of artillery, on the direct road from Yorktown. After the bridge had been constructed over Warwick river, Gen. Smith advanced on the narrow road from the Federal left to Yorktown. He encountered a Confederate force, which fell back before him.

A report of this was sent to the commander-in-chief, who ordered Gen. Stoneman to the other road to press forward, and endeavor to intercept this retiring force before its junction with the main body, which was supposed to be at Williamsburg. Gen. Stoneman pushed forward with all the rapidity possible in the miry condition of the roads, and as he came out at the point where the road from Warwick Creek united, he was saluted by an artillery fire from numerous fieldworks known as Fort Magruder. A rain attempt was made to take this work with cavalry, during which Major Williams displayed great bravery, but the column was forced to retreat and await the arrival of the infantry. Gen. Smith's division subsequently arrived, but the lateness of the hour and the heavy rain caused the attack to be put off.

The pursuit by Gen. McClellan's forces had been so rapid that the Confederate officers found it to be necessary to give it a check, in order to continue their retreat with success. This led to the battle of Williamsburg on the next day, and the retreat of the Confederate army. Their plan for the campaign was thus developed. It was to delay the Federal army as long as practicable at Yorktown, and thus secure time to place Richmond in a defensive condition, and also to meet them in final battle near the marshes of the Chickahominy river.

The Confederate position at Williamsburg consisted of thirteen works, extending nearly across the peninsula. Excepting two or three narrow roads, it was approachable only through dense forests. These roads were made worse by a heavy rain which commenced on Sunday afternoon, the 4th, and continued during the next day.

When Sunday night came, the division of Gen. Smith, of Keyes's corps, had reached Gen. Stoneman's position after he fell back from Fort Magruder. Gen. Hancock's brigade formed the advance of this division. Gen. Hooker, of Heintzelman's corps, was approaching on the left by the road from Warwick river. His force consisted of the 11th Massachusetts, 5th, 6th, and 7th Wisconsin, 26th Pennsylvania, Sickles's New York brigade, and four batteries. Thus the advance of the Federal line had arrived within about two and a half miles of the works at Williamsburg. The Union troops slept on their arms without tents, without food, and in a hard rain. The Confederates determined to make the attack in the morning upon the Federal left and rear. About eight o'clock they threw out a body of infantry on their right, which soon exchanged fire with the advance of Gen. Hooker's division. This continued intermittently for some time. Some light batteries became engaged, and drove the enemy back until they came within range of his heavy guns, when the former suffered severely. Bramhall's battery lost all its horses, the guns became mired, and the forces of the enemy pressing upon it in greatly increased numbers, it was lost. Encouraged by this success, the enemy pushed

forward, and Gen. Hooker was finally forced to give way and fall back, leaving his wounded, about two thousand in number, behind. The Confederates followed him as he fell back, until the division of Gen. Kearney came up and restored the battle. At the same time the enemy was strongly reinforced, and the fight was sharp and fierce. The state of the roads had prevented an earlier arrival of Gen. Kearney's division. His intrepidity was brilliantly shown on this occasion, although Gen. Heintzelman commanded the joint divisions. Meantime the part of the army on the road to the right remained passive. A single division only had come up. Of this the brigade of Brig.-Gen. Peck, of Couch's division of Gen. Casey's corps, was ordered by Gen. Sumner, who was in chief command, into the woods on the left toward the point where the battle was raging against Gen. Hooker's division. This brigade was composed of the 98d, 98th, and 102d Pennsylvania, the 55th and 62d New York, and West's battery. Placed on the right of that division, with other regiments amounting to six thousand men, it stopped the Confederate advance by repulsing with great obstinacy every attempt made. Supported later in the day by Gen. Palmer's brigade, they formed a strong centre.

Gen. Smith's division had formed on the right of the Federal line, and at an early hour a reconnoissance was made with a view of finding a route to the enemy's left flank. One was finally found, which had been overflowed with water by the enemy, and another was cut through the woods. The only obstacles to reaching the flank were two forts, strong from position and construction. To explore this route in force, and if possible occupy these works, Gen. Hancock was sent forward in the afternoon with his brigade. This consisted of the 6th and 7th Vermont, 5th Wisconsin, 38d and 49th New York, and Kennedy's battery. The two works were found to be unoccupied, and garrisoned by his men. A third at a distance he attacked with artillery and silenced. The enemy, seeing the fatal consequences to themselves from this attack, if successful, sent out two brigades to drive back the Federal force. The latter allowed them to come up, and received them with a most destructive fire of artillery. The enemy unshaken pushed forward within thirty yards of the cannon's mouth, when they wavered. Gen. Hancock, seizing the moment, ordered his brigade to charge upon them with the bayonet, which they could not withstand, and broke and fled, leaving their dead and wounded on the field. Gen. McClellan now arrived, and gave orders to support Gen. Hancock, and to press the advantage already gained in that direction. In a few minutes seven thousand men were on the march for that point. Night fell before they reached it, and no more was done that day. The ploughed land and the day's rain made a soft bed on which the weary soldiers sank down during that night.

The success of Gen. Hancock on the Confed-

erate left flank caused them to retreat that night, and at daylight all the forts on the Federal front and Williamsburg itself were found completely abandoned by the entire Confederate army. On the roads and in the woods were found the Confederate dead left unburied, and the wounded in their agonies. Their loss in killed and wounded was estimated at nearly a thousand.

Gen. McClellan evidently had not anticipated so serious a resistance at Williamsburg. In a despatch to the Secretary of War on Sunday evening the 4th, he says: "Our cavalry and horse artillery came up with the enemy's rear guard in their intrenchments about two miles on this side of Williamsburg. A brisk fight ensued just as my aid left. Smith's division of infantry arrived on the ground and, I presume, carried his works, though I have not yet heard. The enemy's rear is strong, but I have force enough up there to answer all purposes."

The force that was actually before Williamsburg would have been routed on the next day, if they had not been sustained by the arrival of fresh troops. These troops were delayed greatly by the bad roads. They were a portion of those whom Gen. McClellan, unaware of the great difficulty of the roads, and uninformed of the true state of the case by correct reports of the front, supposed were before Williamsburg. As it was, Gen. Hooker's division alone for hours withstood the enemy, even within hearing of other troops who were unable to come earlier to his relief.

In the evening after his arrival Gen. McClellan sent a despatch to the Secretary of War, in which he says: "After arranging for movements up York river, I was earnestly sent for here. I find Gen. Joe Johnston in front of me in strong force—probably greater a good deal than my own.

"I shall run the risk of at least holding them in check here while I resume the original plan.

"My entire force is considerably inferior to that of the rebels, who will fight well; but I will do all I can with the force at my disposal."

On a subsequent day Gen. McClellan took occasion to address three of the regiments of Gen. Hancock's brigade, which was engaged on the enemy's left. His remarks indicate the importance which he afterward ascribed to the action of the brigade on that day.

To the men of the Fifth Wisconsin regiment he said:

*My Lads:* I have come to thank you for the bravery and discipline you displayed the other day. On that day you won laurels of which you may ever be proud—not only you, but the army, the State, and the country to which you belong. Through you we won the day, and Williamsburg shall be inscribed upon your banner. I cannot thank you too much, and I am sure the reputation your gallantry has already achieved will always be maintained.

To the Seventh Maine regiment he said:

*Soldiers of the Seventh Maine:* I have come to thank you for your bravery and good conduct in the action of

yesterday. On this battle plain you and your comrades arrested the progress of the advancing enemy, and turned the tide of victory in our favor. You have deserved well of your country and your State, and in their gratitude they will not forget to bestow upon you the thanks and praise so justly your due. Continue to show the conduct of yesterday, and the triumph of our cause will be speedy and sure. In recognition of your merit you shall hereafter bear the inscription "Williamsburg" on your colors. Soldiers, my words are feeble; but from the bottom of my heart I thank you.

To the Thirty-third New York regiment he addressed the following:

*Officers and Soldiers of the Thirty-third:* I have come to thank you in person for your conduct and bravery on the 5th of May. I will say to you as I have said to the other regiments engaged with you at that part of the field, that all did well—did all that I could have expected. The other troops engaged elsewhere fought well and did their whole duty, too; but you won the day, and to you and your comrades belongs the credit of the victory of Williamsburg.

You acted like veterans! Veterans of many battles could not have done better. You shall have "Williamsburg" inscribed upon your flag. I have accorded the same privilege to the other regiments engaged with you.

You have won for yourselves a name that will last you through life.

Soldiers, again I thank you.

It has been stated that the division of Gen. Franklin, belonging to the corps of Gen. McDowell, was subsequently sent to the army of Gen. McClellan. This division arrived previous to the surrender of Yorktown, and remained on board of the transports in order to proceed up the York river as soon as the enemy's batteries might be taken. The division was delayed on the 5th by the weather. On the 6th it left Yorktown, and landed at Brick House Point on the same day. This is the point where the Pamunkey river enters the York river and on the right bank of the latter. The Pamunkey is navigable for gunboats of light draft some twenty miles above White House. It unites with the Mattaponi and forms the York river. On the tongue of land between the two rivers at their junction is West Point opposite to Brick House Point. From West Point a railroad runs to Richmond, and crosses the Pamunkey at White House. Although at this time an insignificant village, West Point was anciently a place of considerable pretensions. It is about twenty-five miles by water from Yorktown and about thirty-five by railroad from Richmond. The troops were landed on the same night, and encamped on a plain surrounded on three sides by woods, and on the fourth bounded by the river. That evening a part of the division of Gen. Sedgwick, under Gen. Dana, arrived. During the next day the enemy were discovered in the woods, and made an attack in which they had the advantage for a short time, but were repulsed and driven a considerable distance. Two batteries were brought to bear, which caused them to press upon the Federal left. The gunboats then opened upon them and did effective service, contributing materially to the success of the day. The divi-

sion of Gen. Porter subsequently arrived on transports, but no further skirmishing took place at that position.

The success at Williamsburg proved to be more complete than had been at first expected. The strong works of the enemy, the town, and his sick and wounded being taken, indicated that his loss had been great, and that his retreat was rapid and disorderly. The retreat was followed up by the Federal cavalry for one or two days, and constant skirmishing kept up with the Confederate rear guard. The terrible condition of the roads rendered a more active pursuit out of the question. Three days were spent by the army at Williamsburg looking after their wounded, who were scattered through the woods, and waiting for provisions from Yorktown, the arrival of which was delayed by the state of the roads.

At this date a serious blow was given to the Confederate strength by the loss of Norfolk, the destruction of the Merrimac, and the breaking up of their blockade of the James river, which had been caused by the Merrimac taking a position off Craney Island. On the 7th President Lincoln arrived at Fortress Monroe, and after examining the fortress and the camp at Newport News, urged a movement on Norfolk, which had already been reported as abandoned in consequence of the advance of the army of the Potomac up the peninsula. An expedition was accordingly organized, under the direction of Maj.-Gen. Wool which embarked at Fortress Monroe during the night of the 9th of May, and landed at Willoughby's Point, a short distance from the Rip Raps and eight miles from Norfolk, at daylight on the 10th. The force consisted of the 10th New York, Col. Bendix; 20th do., Col. Weber; 99th do.; 1st Delaware, Col. Andrews; 16th Massachusetts, Col. Wyman; 58th Pennsylvania, Col. Bailey; a battalion of mounted rifles, and a company of 4th regular artillery. Gens. Mansfield and Weber proceeded over a good road on the direct route to Norfolk, but finding the bridge over Tanner's Creek on fire, and a small force of the enemy on the opposite side with three small howitzers, a march of eight miles was then made by the Princess Anne road, around the head of the creek to Norfolk. The defences of the city were found to have been abandoned. At the limits of the city Gen. Wool was met at half past four in the afternoon by the mayor and a committee of the council, who surrendered it. He immediately took possession, and appointed Brig.-Gen. Vielé military governor, with directions to see that the citizens were protected in "all their civil rights." The troops bivouacked on the field outside of the limits of the city for the night. As soon as these ceremonies were completed, and the custom house and other U. S. property taken possession of, Gen. Wool and his aid for the occasion, Secretary Chase, returned to Fortress Monroe. About four o'clock the next morning, a bright light was observed

from Fortress Monroe, in the direction of Craney Island, which was supposed at first to be a signal of some description from the Confederate iron-clad steamer Merrimac or Virginia. It was closely watched by the officers of the picket boats, as well as by the various naval vessels of the fleet, and precisely at half past four o'clock an explosion took place, which made the earth tremble for miles around. In the midst of the bright flames that shot up through the distant blaze, the timber and iron of the monster steamer could be seen flying through the air, while immense volumes of smoke rose up and for a time obscured everything. No doubt was entertained that the Merrimac had ceased to exist, and had doubtless been abandoned by the crew.

A naval reconnoissance was immediately sent out toward Norfolk. The fortifications on Craney Island were found to have been abandoned. They were in four or five separate sections, and constructed by the most skilful engineers. They were left in excellent condition, as were also the extensive barracks which had accommodated during the winter a garrison of over two thousand men. The forts were finely sodded, and all the appurtenances for immediate service were in readiness, with supplies of ammunition in sheds near each of the forty heavy guns mounted in different parts of the works. On the main front of the island, commanding the approaches by the river channel, the works were casemated. Nine of these casemates were finished, in each of which were nine or ten-inch guns, principally Dahlgrens, and the work of erecting five more casemates was in progress at the time of the evacuation, in one of which a gun was mounted. The whole number of guns mounted was thirty-nine, of which two were Parrotts and a number rifled Dahlgrens. There were also about six guns in the works which had not been mounted. None of them had been removed.

On the line of the river leading from Craney Island to Norfolk there were not less than six heavy earthworks, mounting in all about sixty-nine cannon, all of which were in position, except those that were in the works near the Naval Hospital. These had been taken to Richmond.

Not far above Craney Island was the river barricade. Although the river is here nearly a mile wide, a line of piles had been driven from shore to shore, with the exception of an opening in the centre of the channel for vessels to pass in and out. Here were two steam pile-drivers which had been used for this work, and near the opening was moored the hulk of the old frigate United States, which it was proposed to sink in case Federal vessels should have succeeded in passing the fortifications.

Immediately commanding this river barricade was a casemated battery, forming a half circle, and mounting eleven heavy guns. On the opposite bank of the river was another battery, with two or three other small works, before



old Fort Norfolk on one side of the river, and the Naval Asylum batteries on the other, were reached.

In addition to the amount of ammunition left in the sheds of the batteries, the magazines, of which there was a great number, were well filled. The amount of powder in the magazines was estimated at five thousand pounds, and the fixed ammunition could be enumerated by the cargo. All the workshops, storehouses, and other buildings at the Gosport navy yard were burned, and the dry dock had also been partially blown up with powder on the night after Norfolk was surrendered. While this was taking place, another party was engaged in burning the shipping and steamboats in the harbor. There is no doubt this vast sacrifice was permitted by the Confederate Government, only to enable it to summon to Richmond the troops in and about Norfolk under Gen. Huger. They were about eighteen thousand in number.

At the same time when this movement was made on Norfolk, steps were taken to open the blockade of James river. On the 8th of May the gunboats Galena (iron clad), Aroostook, and Port Royal started up the river, and were successful in silencing the batteries at its mouth and on its banks. They were subsequently joined by the Monitor and Naugatuck, and on the 18th were repulsed by a heavy battery at Drury's Bluff, about eight miles below Richmond. (See NAVAL OPERATIONS.) The blockade of the river below that point was raised.

Meantime the army of Gen. McClellan was advancing toward Richmond. On the 8th of May the advance was beyond Williamsburg, on the 11th it was at Barnhamsville, on the 18th at New Kent Court House, and on the 15th at the White House. This was the point where the railroad from West Point to Richmond crossed the Pamunkey river. It took its name from a fine building, once the property of Gen. Washington, but now of his heirs. The railroad was in good order, and locomotives and cars, brought on the transports, were immediately placed on the track. It was intended that the supplies of the army, as it advanced, should be taken over this road. The Pamunkey river, at the White House, was of sufficient depth to float large vessels, and an immense amount of stores was there collected. A reconnaissance was made on the 16th by one of the smaller gunboats, with two companies of infantry under Major Willard, and one section of Ayres' battery, up the Pamunkey river, a distance of twenty-five miles, to a point known as Russell's Landing. A steamboat, a propeller, and fifteen small schooners were found in flames upon their arrival. Most of these vessels were loaded with corn. On the same day the Confederate troops, consisting chiefly of a corps of observation, were driven over the Chickahominy on the main road to Richmond, at Bottom's Bridge, which was burned. When the Federal troops arrived within a half mile of the bridge, a brisk fire of artillery from the opposite side

opened upon them. The Confederate army had now retreated across the Chickahominy, determined beyond that river to dispute the possession of Richmond. The Chickahominy river is formed by the junction of Horsepen Branch, Rocky Branch, North Run, and Brook Run, near Meadow Bridge, five miles directly north of Richmond. All these streams, and several others too small to have names, rise within ten miles northwest of Richmond, in a rough, unfertile country, exceedingly broken and unfit for cultivation.

Meadow Bridge is nearly north of Richmond, five miles in a direct line by railroad, and is the outlet of a considerable swamp, and the place of crossing for Meadow Bridge road and the Virginia Central and Louisa railroad. The stream at this bridge is an insignificant brook, receiving another creek from the Richmond side, a short distance below. Less than two miles from Meadow Bridge is the bridge of the Mechanicsville turnpike, four and one half miles from the Confederate capital and fifteen from Hanover Court House.

Two miles further on, it receives a small creek with the name of Brandy Run, and from this point it grows considerably wider, more sluggish, with swampy shores at intervals, and low banks often overflowed. Near this place is a small bridge, and a road crosses, but little used.

Four miles from Mechanicsville turnpike bridge is New Bridge, in a direct line northeast from the city six miles, and seven and a half miles by the road. Four miles farther, and directly east from the city, is a military bridge. From this bridge three miles farther to Bottom's Bridge the banks of the stream are quite swampy, but it is still of no considerable size, although several creeks have emptied their waters into it. A mile before reaching Bottom's Bridge it is crossed by the Richmond and York River railroad, running to White House and West Point. The course of the river from its source is east-southeast, so that it is constantly leaving Richmond, and at Bottom's Bridge is fifteen miles away from the city. Its nearest point is at Mechanicsville bridge. The bank of the stream on the north side is for the most part rolling bluffs, covered with forests, with an occasional opening, where can be seen finely situated plantations. Upon the south side of the stream, and from one to two miles from the bank, a considerable bluff extends the entire distance to the vicinity of the lower military bridge. This bluff is highest opposite New Bridge, where a point of it is known as Lewis Hill. A road runs along on the brow of this hill, and there are some very fine residences situated upon it, which, as it is only some three or four miles, at most, from the city, are very desirable locations. Other bridges were constructed by orders of Gen. McClellan.

The soil along the York River railroad is of too pliable a nature to admit of the transportation of heavy guns, or, in fact, any others, at the time of severe rains. The same may be said

of all the localities between the Chickahominy and Richmond. After the passage of a hundred teams it becomes necessary to construct new roads. Some days passed in bringing up the rear of the army, in making preparations to cross the Chickahominy, and in securing the conveyance of the supplies for the army. The railroad from the White House became the base for this purpose, and was kept open until the 25th of June. Meantime the Federal army was diminishing in numbers, while the Confederates were gathering troops by every method they could devise. Prisoners were taken, who belonged to regiments which had opposed Gen. Burnside in North Carolina. And Norfolk had been sacrificed to send her troops to Richmond. The conscription act, passed by the Confederate Congress in April, made every man between the ages of eighteen and thirty-five years a soldier. The new levies were now collecting before Richmond.

On the evening of the 21st Gen. McClellan sent the following despatch to the War Department: "I have just returned from Bottom's Bridge; have examined the country on the other side, and made a reconnoissance on the heels of the enemy, who probably did not like the skirmish of yesterday. The bridge will be repaired by to-morrow morning, and others constructed. All the camps have advanced to-day."

On the next day the troops began to cross both at Bottom's Bridge and at the railroad bridge, and took up a position one and a half miles beyond. Reconnoissances made during the day gave no assurance that the Confederates were in any considerable force near at hand, but led to the impression that it was their purpose to make a stand in a selected position near Richmond. On the next day, the 23d, the advance was within seven miles of Richmond. The Confederates were at the same time attacked with shells on the opposite side of the river near New Bridge. This was followed up on the next day with more skirmishing. During these days, since the army had reached the river, the unusual quantity of rain that fell had rendered the roads almost impassable for artillery, at the same time it had greatly retarded the construction of the numerous bridges which Gen. McClellan wished to build over the Chickahominy. There were two principal objects now before the commander-in-chief: one was to capture Richmond, and the other to secure supplies for his army. For this latter purpose, it was necessary for him to be prepared to defend the railroad against every attack upon it. The Confederate general, Johnston, by having possession of the bridges over the river on the north of Richmond, could at any moment throw a force over and attack Gen. McClellan's line of supplies. The river therefore was necessarily made passable to the Federal army at all times, to enable the commander to mass his troops on either side as might be necessary.

While arrangements were making to render the position of the Army of the Potomac safe

and secure its successful advance upon Richmond, Gen. McClellan began to look anxiously for the expected cooperation of Gen. McDowell. It was evident that the retreat of the enemy could be made but very little farther. The campaign had ripened for the battle, and the conflict must be near at hand. The enemy had always declared that Richmond would never be captured so long as any men were left to defend it. They had shown their willingness to wait, and no one believed they would retire within the defences of Richmond until they were forced to do it by the disastrous issue of a battle.

On the 17th of May, the War Department sent the following instructions to Gen. McClellan. Unfortunately the reinforcements spoken of therein, were destined never to arrive:

WAR DEPARTMENT,  
WASHINGTON CITY, D. C., May 17, 1862. }

Maj.-Gen. George B. McClellan, Commanding  
Army of the Potomac before Richmond:

Your despatch to the President, asking for reinforcements, has been received and carefully considered. The President is not willing to uncover the capital entirely, and it is believed that even if this were prudent, it would require more time to effect a junction between your army and that of the Rappahannock, by the way of the Potomac and York rivers, than by a land march.

In order, therefore, to increase the strength of the attack upon Richmond at the earliest possible moment, Gen. McDowell has been ordered to march upon that city by the shortest route. He is ordered—keeping himself always in position to cover the capital from all possible attack—so to operate as to put his left wing in communication with your right, and you are instructed to cooperate so as to establish this communication as soon as possible. By extending your right wing to the north of Richmond, it is believed that this communication can be safely established, either north or south of the Pamunkey river. In any event, you will be able to prevent the main body of the enemy's forces from leaving Richmond and falling in overwhelming force upon Gen. McDowell. He will move with between thirty-five and forty thousand men.

A copy of the instructions to Maj.-Gen. McDowell is with this. The specific task assigned to his command has been to provide against any danger to the capital of the nation. At your earnest call for reinforcements, he is sent forward to cooperate in the reduction of Richmond, but charged, in attempting this, not to uncover the city of Washington, and you will give no orders either before or after your junction, which can keep him out of position to cover this city. You and he will communicate with each other by telegraph or otherwise as frequently as may be necessary for efficient cooperation.

When Gen. McDowell is in position on your right, his supplies must be drawn from West Point, and you will instruct your staff officers to be prepared to supply him by that route.

The President directs that Gen. McDowell retain the command of the Department of the Rappahannock, and of the forces with which he moves forward.

By order of the President.

EDWIN M. STANTON, Secretary of War.

On the 26th, an order was given for a movement, the design of which was to open a communication with Gen. McDowell, as well as to scatter a force known to be collecting near Hanover Court House to threaten the right of Gen. McClellan and his communications.

About four o'clock on the morning of the 27th, the division of Gen. Marcell, of Gen. Por-

ter's corps, commenced its march in a heavy rain which had continued all night. It turned off from the road to New Bridge, and took that to Hanover Court House. The whole column marched fifteen miles steadily, with great rapidity, and with very little straggling. Soon after noon the enemy's pickets were met and driven in. This was near the railroad and about four miles from the Court House. The advance, consisting of Gen. Martindale's brigade, composed in part of the 18th and 22d Massachusetts, 2d Maine, and 25th New York, had met the enemy in considerable force. The latter regiment suffered severely by the enemy on either flank, until the artillery opened its fire. This continued for half an hour, when the arrival of Gen. Butterfield's brigade soon settled the affair. After an advance of a mile farther the Federal force halted. During this halt the enemy marched so as to flank it and made an attack upon its left, when a severe battle ensued, which finally resulted near sundown in driving the enemy from the field. The Federals, in both contests, had fifty-four killed, and one hundred and ninety-four wounded and missing. The loss was chiefly in the 25th New York. The Confederate force was estimated at eight thousand, and wounded prisoners were taken to the hospitals belonging to fourteen different regiments. Their loss was between two and three hundred killed and wounded, and about five hundred taken prisoners. The expedition was under the command of Gen. Porter. The battle was near Peak's Station,

"It needed only an effort of the will, the two armies were united, and the possession of Richmond certain! Alas! this effort was not made. I cannot recall those fatal moments without a real sinking of the heart. Seated in an orchard in the bivouac of Porter, amid the joyous excitement which follows a successful conflict, I saw the Fifth cavalry bring in whole companies of Confederate prisoners, with arms and baggage, their officers at their head. But neither the glad confidence of the Federals nor the discouragement of their enemies deceived me, and I asked myself how many of these gallant young men who surrounded me, relating their exploits of the day before, would pay with their lives for the fatal error which was on the point of being committed. Not only did not the two armies unite, but the order came from Washington to burn the bridges which had been seized. This was the clearest way of saying to the army of the Potomac and to its chief that in no case could they count on the support of the armies of upper Virginia."

Gen. McClellan, in his testimony before the court martial at Washington in the case of Gen. McDowell on Dec. 10, said:

"I have no doubt, for it has ever been my opinion, that the army of the Potomac would have taken Richmond, had not the corps of Gen. McDowell been separated from it. It is also my opinion that had the command of Gen. McDowell joined the army of the Potomac in the month of May, by way of Hanover Court House from Fredericksburg, we would have had Richmond in a week after the junction. I do not hold General McDowell responsible for a failure to join with me on any occasion. I believe that answers the question."

The principal bridge burned was the one over the South Anna river, one of the tributaries of the Pamunkey river. It was on the line of the Richmond and Fredericksburg railroad, and five hundred feet long. The report of the destruction of this bridge, made from the army at the time, says: "It cuts off the communication by railroad between Richmond and the forces under Gen. Jackson." On the 29th the expedition returned to its original camp.

The explanation of this failure on the part of Gen. McDowell to cooperate with the army of Gen. McClellan at this critical moment, involves a statement of the military operations which had been taking place in the Department of the Potomac, the Mountain Department, and the Department of the Shenandoah, and which culminated at this time. On the Confederate side, the design of these military operations was not only to prevent this junction of Gen. McDowell with Gen. McClellan, but also to prevent any reinforcement whatever to the latter. In this last object they were also partly successful.

The corps of Gen. McDowell was not allowed to embark for Fortress Monroe with the other forces of Gen. McClellan by order of the President, as has been stated. The Department



on the Virginia Central railroad. Fredericksburg, the headquarters of Gen. McDowell, was distant about forty-five miles, and his advance was at Bowling Green, distant only fifteen miles. This was the moment for the junction of the two armies. Prince de Joinville thus speaks of the actions of this hour:

of the Rappahannock created soon after, and placed under the command of Gen. McDowell, became the field of his operations. The division of Gen. Franklin having been sent to Gen. McClellan, the forces of Gen. McDowell consisted of the divisions of Gens. McCall and King. These forces were in Virginia, southwest of Washington. On the 15th of April the order for their advance was issued. On the night of that day the advance reached Catlett's Station. On the 17th the march again commenced, and, six miles out, the pickets of the enemy were found and driven in, and several skirmishes took place during the day. On the morning of the 18th the small force of the enemy were driven across the bridges into Fredericksburg, which place they were not prepared to defend, and soon after abandoned it, having destroyed everything of value to themselves which could not be carried away. On the next day the city was surrendered by the authorities. It was so completely under the guns of the Federal force planted opposite the town, that any resistance in its unprotected state would have been useless. The Confederate force which retired before the advance, consisted of one regiment of infantry and one of cavalry. On the 23d of April Gen. McDowell was ordered by the President not to occupy Fredericksburg for the present, but to prepare the bridges and his transportation. On the 30th he was authorized to occupy it. On the 4th of May the bridges across the Rappahannock had been restored, and the city was occupied by the Federal troops. At the same time when the order was given to Gen. McDowell to advance upon Fredericksburg, an order was given to Gen. Shields to withdraw with his division from the corps of Gen. Banks in the Department of the Shenandoah, and to join the corps of Gen. McDowell. Upon the issue of this order detaching Gen. Shields from the command of Gen. Banks, the War Department was warned by experienced military officers that disaster would certainly follow from it. Gen. Shields immediately moved to comply with the order, and on the 19th his division encamped half a mile south of Catlett's Station. He was ordered then to Fredericksburg, and reached Falmouth on the 22d of May.

On the 17th of May the following instructions were given to Gen. McDowell:

WAR DEPARTMENT,  
WASHINGTON CITY, D. C., May 17, 1862. }

To *Maj.-Gen. McDowell, Commanding Department of the Rappahannock:*

**GENERAL:** Upon being joined by Shields's division, you will move upon Richmond by the general route of the Richmond and Fredericksburg railroad, cooperating with the forces under Gen. McClellan now threatening Richmond from the line of the Pamunkey and York rivers. While seeking to establish as soon as possible a communication between your left wing and the right wing of Gen. McClellan, you will hold yourself always in such position as to cover the capital of the nation against a sudden dash by any large body of the rebel forces.

Gen. McClellan will be furnished with a copy of these instructions, and will be directed to hold himself in readiness to establish communication with your left and

to prevent the main body of the enemy's army from leaving Richmond and throwing itself upon your column before a junction between the two armies is effected. A copy of his instructions in regard to the employment of your forces is annexed.

EDWIN M. STANTON, Secretary of War.

A few days previously a small force had crossed over to Fredericksburg by order of Gen. McDowell, but the main body of his corps remained at Falmouth, where it could sustain the advance if necessary. The enemy had retired only a short distance from the town. So far as related to numbers, the division of Gen. Shields was not needed by Gen. McDowell; but the soldiers of the former had been on many a hard field, while those of the latter had hardly stood the shock of battle. The division of Gen. Shields, just from a march of one hundred and ten miles, was appointed to take the advance upon the enemy. This division consisted of the following brigades: first brigade, Gen. Kimball, 4th and 8th Ohio, 14th Indiana, and 7th Virginia; second brigade, Gen. Terry, 7th, 29th, and 66th Ohio, and 7th Indiana; third brigade, Gen. Tyler, 5th Ohio, 1st Virginia, 84th and 110th Pennsylvania; fourth brigade, Col. Carroll acting brig.-gen., 7th and 62d Ohio, 18th Indiana, and 39th Illinois.

On Saturday evening, May 24, the order was received for the division of Gen. Shields and other forces, to fall back.

The following was the order:

WASHINGTON, May 24, 1862.

*Maj.-Gen. McDowell:*

Gen. Fremont has been ordered, by telegraph, to move to Franklin and Harrisonburg, to relieve Gen. Banks, and capture or destroy Jackson and Ewell's forces. You are instructed, laying aside for the present the movement on Richmond, to put twenty thousand men in motion at once for the Shenandoah, moving on the line, or in advance of the line, of the Manassas Gap railroad. Your object will be to capture the force of Jackson and Ewell, either in cooperation with Gen. Fremont, or, in case want of supplies or transportation interfered with his movement, it is believed that the force which you move will be sufficient to accomplish the object alone. The information thus far received here makes it probable that, if the enemy operates actively against Gen. Banks, you will not be able to count upon much assistance from him, but may have even to release him. Reports received this moment are that Banks is fighting with Ewell, eight miles from Harper's Ferry. ABRAHAM LINCOLN.

The reply of Gen. McDowell to this order was as follows:

HEADQUARTERS, DEPARTMENT OF THE RAPPAHANNOCK, }  
May 24, 1862. }

*Hon. E. M. Stanton, Secretary of War:*

The President's order has been received, and is in process of execution. This is a crushing blow to us. IRVIN McDOWELL, Major-General.

To this the President responded as follows:

WASHINGTON, May 24, 1862.

*Maj.-Gen. McDowell:*

I am highly gratified by your alacrity in obeying my orders. The change was as painful to me as it can possibly be to you or to any one.

Everything now depends upon the celerity and vigor of your movements. A. LINCOLN.

The reply of Gen. McDowell to this message is important, as showing the probabilities

that his movement would be unsuccessful. It was as follows:

HEADQUARTERS, DEPARTMENT OF THE RAPPAHANNOCK, }  
OPPOSITE FREDERICKSBURG, May 24, 1862. }

*His Excellency the President:*

I obeyed your order immediately; for it was positive and urgent, and, perhaps, as a subordinate, there I ought to stop; but I trust I may be allowed to say something in relation to the subject, especially in view of your remark that everything depends upon the celerity and vigor of my movements; I beg to say that coöperation between Gen. Fremont and myself to cut off Jackson and Ewell is not to be counted upon, even if it is not a practicable impossibility; next, that I am entirely beyond helping distance of Gen. Banks, and no celerity or vigor will be available as far as he is concerned; next, that by a glance at the map it will be seen that the line of retreat of the enemy's forces up the valley is shorter than mine to go against him. It will take a week or ten days for the force to get to the valley by the route which will give it food and forage, and by that time the enemy will have retreated. I shall gain nothing for you there, and lose much for you here. It is, therefore, not only on personal grounds that I have a heavy heart in the matter, but I feel that it throws us all back, and from Richmond north we shall have all our large mass paralyzed, and shall have to repeat what we have just accomplished.

I have ordered Gen. Shields to commence the movement to-morrow morning. A second division will follow in the afternoon. Did I understand you aright that you wish that I personally should accompany this expedition? Very respectfully,

IRVIN McDOWELL.

The division of Gen. Shields, accompanied by other portions of McDowell's forces, was on the march at noon of the next day, and moved fifteen miles, and the next day, the 26th, encamped six miles beyond Catlett's Station. Early the next morning, moving again, it passed Manassas Junction during the day, where it met a portion of the force driven from Front Royal, and learned that Gen. Banks was flying before Gen. Jackson, and halted at Haymarket. Twelve days previous this division had left Gen. Banks's army to join Gen. McDowell, on his way, as it was believed, to coöperate with Gen. McClellan before Richmond. It had been the division of Gen. Lander, and had become familiar with the Shenandoah Valley, up which they had pursued the enemy from the Potomac to the northern base of the Massanutten Mountains. Now the work of a whole winter and spring was before them to do over again. In coöperation with Gen. Fremont's forces they prepared to aid in cutting off the retreat of Gen. Jackson after having driven Gen. Banks across the Potomac. On the 27th a column under Gen. Kimball, embracing, as a part of it, the entire division of Gen. Shields, commenced its march for Front Royal, which, without serious opposition, it was expected to reach in three days, and Strasburg in four.

The advance of Gen. McDowell at the time it was countermanded had reached Bowling Green, fifteen miles from Hanover Court House, which was two days later occupied by a force from Gen. McClellan's army under Gen. Porter.

The order creating the Mountain Department was issued by the President on the 11th of March. It was supposed at this time that the

plan of the campaign for Gen. Fremont was to move up the left bank of the Big Sandy river in Kentucky, to Prestonville and Pikeville, through Cumberland Gap to Knoxville, and thus command the southern railroad, and cut off any retreat from or any reinforcements to Richmond. On the 29th Gen. Fremont, at Wheeling, assumed the command, and Gen. Rosecrans retired and took command of Gen. Pope's corps under Gen. Grant. The new department was bounded on the east by that of the Potomac under Gen. McClellan, and on the west by that of the Mississippi under Gen. Halleck. Active preparations had been made by Gen. Rosecrans for the spring campaign. On the same day Gen. Fremont issued an order assigning Brig.-Gen. B. F. Kelly to the command of the railroad district, consisting of all of western Virginia, north and east of the counties of Jackson, Roane, Calhoun, Braxton, Lewis, Barbour, and Tucker inclusive, and west of the Alleghanies, Maryland, and Pennsylvania.

Military operations in this department, under Gen. Fremont, commenced about the 1st of April. Gen. Milroy, who had been some time holding the pass of Cheat Mountain in Randolph county in the northern part of the State, advanced twelve miles to Camp Greenbrier, thence nine miles in a northeasterly direction to Camp Alleghany, a position occupied by the enemy, who retreated before him. On the 10th he had occupied Monterey, being an advance of sixteen miles. This position was evacuated by the Confederates, and also Huntersville. The next day he moved toward McDowell, distant ten miles, and occupied it and advanced subsequently to Fort Shenandoah eight miles. Thus far Gen. Milroy had followed the retreating foe from Monterey in the direction of Staunton in the Shenandoah Valley.

On the 3d of May Gen. Fremont left Wheeling and arrived at New Creek on the Baltimore and Ohio railroad, and on the 5th, accompanied by his staff and body guard, and one or two regiments of infantry and a battery, he advanced about six miles; on the 7th he reached Petersburg, a small town twelve miles beyond Moorefield, and forty-four from New Creek. Gen. Schenck's brigade had left Petersburg on the 3d. Their aim was to effect a junction with Gen. Milroy, whose situation was becoming exposed in consequence of forces of the enemy advancing from the east. Gen. Milroy in his advance had driven the Confederates beyond the Shenandoah Mountains, the boundary of Gen. Fremont's department, and had made his headquarters at McDowell. On the 5th of May the 82d Ohio regiment was advanced beyond the Shenandoah Mountains, about sixteen miles from McDowell, for the double purpose of scouting and foraging. The 75th Ohio and 3d Virginia, with Hyman's battery, were encamped at the foot of the mountain on the west side, and the remainder of Gen. Milroy's force was at



McDowell. This is a small town on the Bull Pasture river at the foot of mountains bearing the same name, and about forty miles distant from Harrisonburg in the Shenandoah Valley, where Gen. Banks's forces then were. To prevent the junction of these forces, or to cut them up before Gen. Milroy could be reinforced, Gen. Jackson collected all the Confederate forces in the region, and marched against him. On the 7th he attacked the 32d Ohio, which fell back with the loss of their camp equipage and baggage, through lack of transportation. At the same time the force west of the mountain fell back in order to McDowell, where a stand was determined upon. Gen. Milroy at the earliest moment sent despatches to Gen. Schenck, who was thirty miles distant, to hasten to his assistance. In the afternoon the enemy appeared in large force on the tops of the mountains in the rear of the town, arranging for an attack. A force was immediately sent forward by Gen. Milroy to occupy the hilltops adjacent to the ones upon which the enemy appeared, more for the purpose of skirmishing and reconnoitring than for bringing on a battle. A fierce contest ensued, which was increased by the arrival of Gen. Schenck with his brigade, and continued until night. The forces of the enemy being manifestly greatly superior, Gen. Milroy determined to retreat. The march was commenced at midnight, and at daybreak they had retired thirteen miles. After a halt of two hours it was continued with the enemy pressing upon them. Upon reaching the camp of Gen. Schenck, arrangements were made for protection. Every hill was surmounted with cannon, and ten different regiments were placed to support them, and for over thirty hours the artillery by a constant fire kept the enemy at a distance. On the morning of the 14th all of the enemy had disappeared, which was subsequently explained by the arrival of Gen. Fremont with Blenker's division. The Federal loss in this conflict was twenty killed, one hundred and seventy-seven wounded, and two missing. The Confederate loss was forty killed, and two hundred wounded. It was nearly a flight of the Federal forces, and only the arrival of Fremont probably saved it from final capture. The Federal loss in tents, baggage, and stores was great. The enemy were present in much superior numbers.

Gen. Fremont now made his headquarters at Franklin, eighty miles south of New Creek, twenty-four miles from Monterey, and sixty-five from Staunton. Here he remained quietly, reorganizing and refreshing his forces for ten days. This repulse of his advance, with his withdrawal to Franklin, now gave Gen. Jackson the opportunity to carry out the plans against Gen. Banks as soon as the moment came for their execution. Consequently no further movement of importance was made on the part of Gen. Fremont until he was ordered to hurry to the relief of Gen. Banks. This order was received by him on Saturday, the

24th of May, under the form of a despatch from the Secretary of War, directing him to fall back with his entire command to the support of Gen. Banks. That evening the order was given to be ready for a movement early on the following morning. As early as half past three o'clock on Sunday morning the noise of preparation was heard, and at six o'clock the army was in motion.

It seems that when Gen. Fremont was ordered to go to the relief of Gen. Banks, the order prescribed the route by which he should go. (See p. 109.) This route, thus specified by the President, would have brought Gen. Fremont in the rear of Gen. Jackson; whereas that taken by Gen. Fremont brought him in front of Gen. Jackson. But Gen. Fremont, judging it to be an impracticable route, took the responsibility of going by another. The President telegraphed to him, saying: "You are ordered to go so and so. I hear of you elsewhere. What does this mean?" To which Gen. Fremont replied, giving the reasons, viz.: that he knew of a shorter and easier route by which he could more effectually perform the service desired, and on which his half-famished troops would meet their transportation and supplies. He also stated that when one is "in the field," it is essentially difficult to obey literally orders transmitted from one necessarily unaware of present exigencies, but that if it was expected of him so to do, he would do it. To this the President, with characteristic simplicity, replied that he was satisfied.

The first six miles of the road were indescribably bad, owing to the recent rains and the heavy wagons that had been passing over it. Wounded and sick had been left at Franklin, but the entire train of wagons was taken. At night the army bivouacked about a mile beyond the upper crossing of the South Branch of the Potomac on the road to Petersburg. The distance marched was fourteen miles. On Monday, the 26th, the advance reached Petersburg after noon, having marched sixteen miles, and halted until the next morning. Orders were here issued that knapsacks, tents, and baggage of every description, which could possibly be dispensed with, should be left behind. Five days' rations of hard bread were given to the troops, and on Tuesday, the 27th, after marching twelve miles, they halted on the highlands east of the village of Moorefield. On Wednesday, the 28th, the army advanced ten miles, passing over Hunting Ridge, and about two o'clock halted to rest and await supplies. The roads continually grew worse, and the rain fell steadily. Thursday, no movement was made. A small force under Col. Downey, on a reconnoissance, encountered a small body of Confederate cavalry. On Friday, the 30th, an advance of twenty miles was made, and the army bivouacked at Wardensville. A heavy rain fell during the afternoon. On Saturday, the 31st, the last of the intervening mountain ranges was crossed, and the western

barrier of the Shenandoah Valley alone remained to be traversed. The troops pushed on twelve miles through the rain, and halted at night where the Winchester and Strasburg roads divide. On the narrow ridges, along which the path wound in constant ascent, there was no plane or table land for camp. That rainy night the tired troops dropped and slept by the roadside or in the swimming fields. The next morning, Sunday, June 1, the advance moved at six o'clock, and at eight the whole column was in motion on the road to Strasburg. In about an hour and a half later a skirmish ensued near Strasburg, and Gen. Fremont had reached the position to cooperate with the force of Gen. McDowell against the advance of the enemy upon Gen. Banks.

After the battle of Winchester, on the 28d of March, the retiring Confederate forces in the Shenandoah Valley were followed up by Gen. Banks. On the 1st of April he moved from Strasburg to Woodstock, where his entrance was disputed by a force of cavalry, infantry, and artillery under Col. Ashby. They however retreated to Edinburg, destroying one railroad and two turnpike bridges. The advance was subsequently continued with occasional skirmishes, and on the 26th Harrisonburg was occupied. A considerable body of Confederate troops was in the neighborhood, but in a position from which a retreat could easily be made.

The order of the President, which divided the army in Virginia into five corps, placed the fifth under the command of Gen. Banks. It was to be composed of his division and that of Gen. Shields, which had previously been commanded by Gen. Lander. This was the force now encamped near Harrisonburg. About the 15th of May an order was issued from the War Department withdrawing the division of Gen. Shields from the corps of Gen. Banks, and directing him to report immediately at Catlett's Station on the Orange and Alexandria railroad, as above stated. At the same time orders were given to Gen. Banks to fall back to Strasburg and fortify. Gen. Shields left at once, and on his arrival at Catlett's Station he was ordered to join Gen. McDowell at Fredericksburg immediately.

At Strasburg the Massanutten range of mountains rise in the middle of the valley, and divide it. Strasburg is favorably located for defence against an attack from the south by the western valley. But the eastern valley, by opening out at Front Royal, affords another road to the Potomac, and also a good plank road, which runs direct to Winchester, going round Strasburg.

Gen. Banks had not actually fallen back to Strasburg when Gen. Shields marched over the mountain and down the eastern branch of the valley to Front Royal. At that very time an attack was expected on the front, and a portion of his forces had been daily skirmishing with a Confederate force in the gap of the

Massanutten Mountains. It was also known that Gen. Jackson, having attempted to dislodge Gen. Milroy in the Mountain Department, was returning to the Shenandoah Valley, and that Gen. Ewell was with a strong force on the road running from Harrisonburg to Gordonsville, and also that Gen. Taylor was still higher up the valley with another Confederate force. In addition, Gen. Jackson could be easily reënforced from Gordonsville. With this force menacing the valley, Gen. Banks was left with less than six thousand men, including cavalry and artillery, to defend the whole valley, and that, too, before he had time to prepare himself for resistance by fortifications.

Eastward of Front Royal there was another force under Gen. Geary, charged with the protection of the Manassas Gap railroad. The headquarters of Gen. Geary were at Rectorstown, and there were only between seven and eight hundred troops at Front Royal. Still farther east, at Catlett's Station, on the Orange and Alexandria railroad, about ten miles south of Manassas Junction, was the brigade of Gen. Duryea, consisting of three New York and one Pennsylvania regiment. These forces formed the connection between Gen. Banks and the main body of the army of the Rappahannock, under Gen. McDowell, at Fredericksburg.

The enemy, knowing the position and strength of these forces, formed a plan to capture the entire force of Gen. Banks. This plan was to be executed on the proper signal being given from Richmond. At this time Gen. McClellan was within fifteen miles of Richmond. Gen. McDowell had been reënforced by Gen. Shields, and orders were expected every hour for him to advance toward Richmond. It was all-important for the defence of that capital that reënforcements should be prevented from reaching Gen. McClellan. After the junction of Gens. Shields and McDowell, dense columns of smoke could be seen at evening ascending for miles south of Fredericksburg, which were caused by the burning of bridges to retard the Federal advance. Something greater than the mere burning of bridges was needed; for it was not only necessary to prevent the Federal reënforcements to Gen. McClellan, but also to gain time to accumulate the Confederate forces before Richmond from such parts of the South as they could be taken, and by the levies of the conscript law. The moment had come for the dash on Gen. Banks, and the signal from Richmond was given. Meanwhile Gen. Banks, according to the orders of the War Department, had fallen back, and now occupied Strasburg. The first movement of the enemy, who had retired from their advance on Fremont, and were already concentrated under Gens. Jackson and Ewell for the purpose, was to advance a heavy column rapidly up the valley between the Blue Ridge and Massanutten mountain range to Front Royal, with the design of capturing the force there, and then press on by a good plank road to Winchester, and



thus get in the rear of Gen. Banks. The guard at Front Royal consisted of the 1st Maryland regiment, Col. Kenly, with three companies of the 29th Pennsylvania, two rifled guns of Knapp's battery, and two companies of the 5th New York cavalry. To their bravery is due the partial defeat of the Confederate plan. On Friday noon, May 23, the enemy were reported to be approaching, and Col. Kenly formed in a position about one mile east of the Shenandoah river. The fight commenced by a strong dash of cavalry under Col. Ashby upon this position. After a contest of two hours the enemy were repulsed with considerable loss. Finding that a large force of infantry was approaching to the aid of the cavalry, Col. Kenly ordered his men to fall back to the west side of the Shenandoah and to destroy the bridges after them. This was done in good order and the smaller bridge destroyed; but a flanking force of the enemy fording above came upon them before the larger one was destroyed. Col. Kenly immediately got his guns in position and formed his men, and another struggle ensued, which checked the enemy a couple of hours longer. Finding the force of the enemy increasing, he placed his artillery in the rear and commenced falling back. This was continued for three miles, when the force was overwhelmed by a charge of the enemy, their lines broken, and no further resistance could be made. Col. Kenly was severely wounded, but afterward recovered. This check retarded the Confederate advance.

The news of this affair reached Gen. Banks that evening, with such details as convinced him that the enemy were at hand with a force from fifteen to twenty thousand strong. It was evident to him from the large Confederate force, composed as it must be of all their troops in the valley concentrated, that they were close upon him for some purpose not yet developed. That purpose must be nothing less than the defeat of his own command, or its possible capture by occupying Winchester, and thus intercepting supplies or reinforcements and cutting off all opportunity for retreat. Under this interpretation of the enemy's plans, one of three courses was open for him to pursue: first, a retreat across the little North Mountain to the Potomac river on the west; second, an attack on the enemy's flank on the Front Royal road; third, a rapid movement direct upon Winchester with a view to anticipate the occupation of the town by the enemy, and thus place his own command in communication with its original base of operations in the line of reinforcements by Harper's Ferry, and secure a safe retreat in case of disaster.

To remain at Strasburg was to be surrounded; to move over the mountains was to abandon his train at the outset, and to subject his command to flank attacks, without possibility of succor; and to attack the enemy in such overwhelming force could only result in certain destruction. It was, therefore, determined by Gen. Banks that to enter the lists with the enemy in a race or a battle, as he should choose, for the

possession of Winchester, the key of the valley, was, for him and his force, the path to safety.

Accordingly, the advance guard was called in, and at three o'clock on the next morning several hundred disabled men, left in charge by Gen. Shields's division, were put upon the march to Winchester, followed by the wagon train under escort of cavalry and infantry. The rear was protected by nearly the whole force of cavalry and six pieces of artillery. The attack of the enemy was expected in the rear. When all the column except the rear guard had passed Cedar Creek, three miles from Strasburg, information was received from the front that the enemy had attacked the train and was in full possession of the road at Middletown. The danger being now in front, the troops were ordered to the head of the column and the train to the rear. After this change the head of the column encountered the enemy in force, fifteen miles from Winchester, who were attacked with artillery and infantry and driven back some two miles. The neglect of the enemy to attack the train and throw it into confusion when at the head of the column secured a successful continuation of the march. On the remainder of the route to Winchester, the enemy pressed the main column with the utmost vigor, and defeated at every point all efforts of detachments to effect a junction with it. At five o'clock in the afternoon the advance guard arrived at Winchester, and Gen. Banks became satisfied that the force of the enemy was not less than twenty-five thousand men. His command consisted of two brigades of less than four thousand men, with nine hundred cavalry, ten Parrott guns, and one battery of smooth six pounders. To this should be added the 10th Maine regiment of infantry and five companies of Maryland cavalry, stationed at Winchester. During the night Gen. Banks determined to test the strength of the enemy by actual collision, and measures were promptly taken to prepare the troops. The rolling of musketry was heard during the latter part of the night, and before the break of day a sharp engagement occurred at the outposts. Soon after four o'clock the artillery opened its fire, which continued without cessation until the close of the engagement.

The main body of the Confederates was hidden during the early part of the action by the crest of a hill and the woods in the rear.

Their force was massed apparently upon the Federal right, and their manœuvres indicated a purpose to turn them upon the Berryville road, where, it appeared subsequently, they had placed a considerable force with a view of preventing reinforcements from Harper's Ferry. But the steady fire of the Federal lines held them in check until a small portion of the troops, on the right of the Federal line, made a movement to the rear. This was done under the erroneous impression that an order to withdraw had been given. No sooner was this observed by the enemy than its regiments swarmed upon the

crest of the hill, advancing from the woods upon the Federal right, which, still continuing its fire, steadily withdrew toward the town.

The overwhelming Confederate force thus suddenly showing itself, made further resistance unwise, and orders were sent to the left to withdraw, which was done in an orderly manner. By this engagement the enemy were held in check five hours.

The retreat was now continued in three parallel columns, each protected by an efficient rear guard, in the direction of Martinsburg, with the hope of meeting reinforcements. The pursuit of the enemy was prompt and vigorous, and the retreat rapid and without loss. At Martinsburg the columns halted two hours and a half, and the rear guard remained in the rear of the town until seven in the evening, and arrived at the river at sundown, forty-eight hours after the first news of the attack on Front Royal. It was a march of fifty-three miles, thirty-five of which were performed in one day. The scene at the river when the rear guard arrived was of the most animated and excited description. A thousand camp fires were burning on the hillside; a thousand carriages of every description were crowded upon the banks of the broad stream between the exhausted troops and their coveted rest. The ford was too deep for the teams to cross in regular succession; only the strongest horses, after a few experiments, were allowed to essay the passage over before morning. The single ferry was occupied by the ammunition trains, the ford by the wagons. The cavalry was secure in its form of crossing. The troops only had no transportation. No enemy appeared in sight. Fortunately there were several boats belonging to the pontoon train brought from Strasburg, which were launched and devoted exclusively to the soldiers. Gen. Banks says in his report: "There never were more grateful hearts in the same number of men than when at midday, on the 26th, we stood on the opposite shore." The loss was as follows: killed, 88; wounded, 155; missing, 711; total, 904. The wagon train consisted of nearly five hundred wagons, of which fifty-five were lost. All the guns were saved. The loss of the enemy has not been stated.

On the morning of the 28th, Gen. Jackson issued the following address to his soldiers:

HEADQUARTERS, V. D.,  
WINCHESTER, May 28, 1862. }  
*General Order, No. 58.*

Within four weeks this army has made long and rapid marches, fought six combats and two battles, signally defeating the enemy in each one, capturing several stands of colors and pieces of artillery, with numerous prisoners and vast medical and army stores, and finally driven the boastful host, which was ravishing our beautiful country, into utter rout. The General commanding would warmly express to the officers and men under his command his joy in their achievements, and his thanks for their brilliant gallantry in action, and their obedience under the hardships of forced marches, often more painful to the brave soldier than the dangers of battle.

The explanation of the severe exertions to which the commanding General called the army, which were endured by them with such cheerful confidence in him, is now given in the victory of yesterday. He receives this proof of their confidence in the past with pride and gratitude, and asks only a similar confidence in the future. But his chief duty to-day, and that of the army, is to recognize devoutly the hand of a protecting Providence in the brilliant successes of the last three days, which have given us the result of a great victory without great losses, and to make the oblation of our thanks to God for his mercies to us and our country in heartfelt acts of religious worship. For this purpose the troops will remain in camp to-day, suspending as far as practicable all military exercises, and the chaplains of the regiments will hold divine service in their several charges at 4 o'clock P. M., to-day.

By order of Maj.-Gen. JACKSON.

R. D. DANBY, Asst. Adj.-Gen.

When the news of the attack on the Maryland regiment at Front Royal on the 28d, reached Gen. Geary, who, with his force, was charged with the protection of the Manassas Gap railroad, he immediately began to move to Manassas Junction. His troops hearing the most extravagant stories of the fate of the Maryland regiment, and supposing they were about to be swallowed up, burnt their tents and destroyed a quantity of arms. Gen. Dur-yea, at Catlett's Station, became alarmed on learning of the withdrawal of Gen. Geary, took his three New York regiments, leaving the Pennsylvania one behind, and hastened back to Centreville, and telegraphed to Washington for help. He left a large quantity of army stores behind, and also for two days his camp equipage. A panic prevailed at Catlett's Station and Manassas Junction for two days. At night the camps were kept in constant alarm by the sentinels firing at stumps or bowing bushes, which they mistook for Confederate guerillas. The alarm spread to Washington, and Secretary Stanton issued orders calling for the militia of the loyal States to defend that city.

The following is the despatch sent to the Governor of Massachusetts:

WASHINGTON, May 25, 1862.

*To the Governor of Massachusetts:*

Intelligence from various quarters leaves no doubt that the enemy in great force are marching on Washington. You will please organize and forward immediately all the militia and volunteer force in your State. EDWIN M. STANTON, Secretary of War.

This alarm at Washington, and the call for its defence, produced a most indescribable panic in the cities of the Northern States, on Sunday, the 25th, and two or three days afterward.

The Governor of New York, on Sunday night, the 25th, telegraphed to Buffalo, Rochester, Syracuse, and other cities as follows:

Orders from Washington render it necessary to forward to that city all the available militia force. What can Buffalo do? E. D. MORGAN.

Governor Curtin, of Pennsylvania, issued the following order:

HEADQUARTERS PENNSYLVANIA MILITIA, }  
HARRISBURG, May 26. }  
*General Order, No. 23.*

On pressing requisition of the President of the United States in the present emergency, it is ordered that

the several major-generals, brigadier-generals, and colonels of regiments, throughout the Commonwealth, muster, without delay, all military organizations within their respective divisions or under their control, together with all persons willing to join their commands, and proceed forthwith to the city of Washington or such other points as may be indicated by future orders.

By order A. G. CURTIN, Governor and Commander-in-Chief.

(Signed)

A. L. RUSSELL, Adjt.-Gen.

The Governor of Massachusetts issued the following proclamation:

*Men of Massachusetts!*—The wily and barbarous horde of traitors to the people, to the Government, to our country, and to liberty, menace again the national capital. They have attacked and routed Maj.-Gen. Banks, are advancing on Harper's Ferry, and are marching on Washington. The President calls on Massachusetts to rise once more for its rescue and defence.

The whole active militia will be summoned by a general order, issued from the office of the Adjutant-General, to report on Boston Common to-morrow; they will march to relieve and avenge their brethren and friends, and to oppose with fierce zeal and courageous patriotism the progress of the foe.

May God encourage their hearts and strengthen their arms, and may He inspire the Government and all the people!

Given at Headquarters, Boston, 11 o'clock, this (Sunday) evening, May 25, 1862.

JOHN A. ANDREW.

Over three thousand men responded on Monday.

The Governor of Rhode Island issued the following order:

PROVIDENCE, May 25, 1862.

Citizens of the State capable of bearing arms will at once report themselves to the nearest military organizations.

The commandants of the chartered and volunteer military companies will at once organize their companies, and the men so reporting into companies of eighty-three men rank and file, and report to these headquarters, when they will be armed, equipped, and moved under the direction of the Commander-in-Chief to Washington, to protect the national capital from the advance of the rebels who are now rapidly approaching.

Gen. Robbins is directed to organize and command the first regiment, and will order his brigade under arms and form it into a regiment.

The second regiment will be under command of Capt. Bliss, of the United States Army.

The Providence Marine Corps of artillery will be placed under the command of Lieut.-Col. E. C. Gallup as captain, and he is directed to organize the same.

Col. Shaw is ordered to assemble the National Guard for organization.

Rhode Island troops will move through Baltimore, and if their progress is impeded by the rebel mob of that city, they will mete out to it the punishment which it has long merited. Our regiments will move to Washington to defend the capital in common with thousands of our patriotic countrymen, who will rush to arms to ward off the danger which is imminent.

WM. SPRAGUE.

AVG. HOFFIN, Assistant Adjutant-General.

The Governor of Ohio issued the following proclamation:

COLUMBUS, O., May 26.

*To the Gallant Men of Ohio:* I have the astounding intelligence that the seat of our beloved Government is threatened with invasion, and am called upon by the Secretary of War for troops to repel and overwhelm the ruthless invaders.

Rally, then, men of Ohio, and respond to this call, as becomes those who appreciate our glorious Government. Three classes of troops will be accepted:

First. For three years, or during the war.

Second. For a term of three months.

Third. For guard duty within the limits of the State.

All are requested to report for duty at Camp Chase, where the organization will take place.

The number wanted from each county has been indicated by special despatches to the several Military Committees.

Everything is valueless to us if our Government is overthrown.

Lay aside, then, your ordinary duties, and help to bear aloft the glorious flag unfurled by our fathers.

DAVID TOD, Governor.

At the same time the Secretary of War at Washington, caused the following order to be issued:

WASHINGTON, May 25, 1862.

*Ordered.* By virtue of the authority vested by an act of Congress, the President takes military possession of all the railroads in the United States, from and after this date, until further orders, and directs that the respective railroad companies, their officers and servants, shall hold themselves in readiness for the transportation of troops and munitions of war, as may be ordered by the military authorities, to the exclusion of all other business.

By order of the Secretary of War.

M. C. MEIGS, Quartermaster-General.

When the alarm thus indicated in the headquarters of Government had disseminated itself throughout the military and social ramifications of society, the excitement was almost tumultuous. In Baltimore, crowds pursued persons suspected of sympathy with the cause of the South, until all such disappeared from the streets. The display of flags was demanded from public buildings. Almost half a million of men offered themselves for the defence of Washington within twenty-four hours after the issue of the proclamations.

Meanwhile Gen. Jackson, having seen Gen. Banks safely escaping to the ford of the Potomac, turned away from further pursuit to carry out the other details of his plan, little conceiving of the panic his movements had occasioned in the departments at Washington and the offices of the Governors of States. In fact a captured despatch from Gen. Johnston to Gen. Jackson shows that the chief object of Gen. Jackson's movement was to prevent reinforcements to Gen. McClellan. The effect of this causeless panic on the part of the authorities at Washington was extremely disastrous to the Federal cause; fully as much so as the groundless fears for the safety of the capital, which determined the detention of Gen. McDowell's corps from the army of the Potomac in the beginning of the month of April. The War Department manifestly did not realize the self-evident fact, that Washington being strongly fortified, its surest defence consisted in the presence of a large army threatening Richmond from the peninsula.

On the 28th Gen. Jackson advanced upon Harper's Ferry from Charlestown, driving in before him a Federal reconnoitring force consisting of the 111th Pennsylvania infantry, Col. Schlan-

decker; the 1st Maryland cavalry, Major Deems, and a section of Reynolds's battery. Small bodies of the enemy appeared in the neighborhood during that and the ensuing day, as if with the object of alluring the Federal forces from their strong defensive position to one where they could be more easily attacked and overpowered. This was the opinion of the Federal commander. The whole force of Gen. Jackson was not before Harper's Ferry. Finding the strength of front presented against him, he determined to collect all the plunder he could convey with prisoners, and retire. To effect this object more securely and to deceive his enemy respecting his movements, he left a force with Gen. Ewell, which became his rear guard, and which made the demonstration upon Harper's Ferry. Gen. R. Saxton, who was in command at Harper's Ferry, fearing a flank movement on the part of the enemy, crossing the Potomac above and occupying Maryland Heights on the Maryland side at the same time that an attack should be made in front, determined to defeat it. He therefore withdrew his forces from Bolivar Heights on the Virginia side to an inner line of defence, on the heights known as Camp Hill, immediately above the town of Harper's Ferry. The occupation of this inner line presented a twofold advantage: First, that being much less extended, it could be held by a smaller force—the enemy, from the nature of the ground, being unable to bring into action a larger force than the Federal; secondly, that it would enable Gen. Saxton to bring his naval battery on the Maryland Heights to bear upon the enemy, as they advanced down the declivity of Bolivar Heights into the valley which separates it from Camp Hill. They would thus be exposed for a considerable time to a heavy fire from this formidable battery, where great elevation would enable it to throw shells directly over the heads of the Federal forces on Camp Hill into the face of the advancing foe. With the force rendered by this contraction of his front available for other purposes, he deemed it prudent to occupy the crest of the hill above the naval battery, on the Maryland shore, to frustrate any attempt of the enemy to take this hill in the rear and turn his batteries against him.

On Friday night, the 30th, about dark, the enemy advanced beyond Bolivar Heights to storm the works on Camp Hill. The batteries on Camp Hill, and the one on Maryland Heights, opened upon them. The scene at this time was very impressive. The night was intensely dark; the hills around were alive with the signal lights of the enemy; the rain descended in torrents; vivid flashes of lightning illumined at intervals the green and magnificent scenery, while the crash of the thunder, echoing among the mountains, drowned into comparative insignificance the roar of Federal artillery.

After an action of about one hour's duration the enemy retired. He made another unsuc-

cessful attack at midnight, with regiments of Mississippi and Louisiana infantry, and after a short engagement disappeared. Signal lights continued to be seen in every direction.

A reconnoissance the next day developed that the rear of the Confederate force passed through Charlestown about one hour before the arrival of the Federal reconnoitring force from Harper's Ferry.

Gen. Jackson was now on his retreat. If he had not accomplished all that he aimed at, the result will show that he was completely successful in cutting off nearly all reinforcements to Gen. McClellan. The fear of having his own retreat cut off now caused his rapid movements. Gen. Fremont from the west, and Col. Kimball with the division of Gen. Shields from the east, were on the march to intercept him. The Confederate movements, which had been made to prevent the retreat of Gen. Jackson from being cut off, consisted in the march of Gen. Smith up the Shenandoah from Strasburg to prevent Gen. Fremont from crossing over, as he was ordered, to Harrisonburg. If Gen. Fremont could have successfully crossed to this point, he might have taken up a position so far in the rear of Gen. Jackson as to have effectually cut him off. It has been said that it was impossible for Gen. Fremont to cross to Harrisonburg. When he received the order to come to the aid of Gen. Banks he was at Franklin, sixty-five miles from Staunton, and a less distance from Harrisonburg. Instead of taking this route, he marched a hundred miles to Strasburg. The Confederate forces which attacked Gen. Milroy and drove him back from McDowell, crossed the mountains, whence they retired to Staunton or Harrisonburg. This was some three weeks previous. The enemy also expected Gen. Fremont to cross to New Market or Harrisonburg, thus showing that no local obstacles prevented. The means of transportation were limited; the supplies could hardly have been found by that route.

On Thursday, the 29th, Gen. Jackson ordered a retrograde movement, and sent off his train and prisoners. Early Friday morning, he left camp between Halltown and Charlestown, and his advance rested the first night at or near Middletown, and the next day (Saturday) entered Strasburg. On Saturday morning, Gen. Ewell, disappearing from Harper's Ferry with the rear guard, followed Gen. Jackson, and encamped on Saturday night at Middletown, thus performing a march of thirty-four miles in one day.

Where now were the pursuers of Gen. Jackson, who were to cut off his retreat? On Saturday night the advance of Gen. Fremont arrived at Brent's Gap, about six miles northwest of Strasburg. It was at noon of the previous day that Gen. Fremont was expected to be in Strasburg by Gen. Shields, who was advancing from the east, having been ordered to be in Front Royal at that hour, which he was. The ad-

vance of Gen. Fremont's force on Sunday, June 1, encountered the enemy three or four miles from Strasburg, on the road to Winchester. Gen. Jackson had arrived in Strasburg on the previous day, and tarried to secure the safe arrival and departure of all his force. This encounter of the advance of Gen. Fremont was with the rear of Gen. Jackson. Col. Cluseret, with the 60th Ohio and 8th Virginia and a battery, formed this advance. The contest was with artillery, and was continued by Col. Cluseret until about noon, when he was ordered to retire under the hope of drawing Gen. Jackson on to attack the position which Gen. Fremont had in the meanwhile taken. He had formed a line of battle in a strong position, with Gen. Milroy on the left, Gen. Schenck on the right, and Gen. Stahl in the centre, with Blenker's division in reserve. In this affair five of the 8th Virginia and two of the 60th Ohio were wounded. While Gen. Jackson's rear was thus engaged with the advance of Gen. Fremont, the main body of his troops was pushing on through Strasburg, which was accomplished on Sunday. Thus Gen. Jackson reached Strasburg just in time to pass between Gen. McDowell on the one side, and Gen. Fremont on the other. The advance of Gen. McDowell reached Strasburg soon after the advance of Gen. Fremont. The afternoon wore away without any appearance of Gen. Jackson. The truth was that the attack on the advance of Gen. Fremont was made to divert his attention from the retreating movement Gen. Jackson was then making. A reconnoissance was made during the night beyond Strasburg. On Monday morning, June 2, Gen. Fremont pushed on to Strasburg only to find that Gen. Jackson was on his way to Woodstock unchecked and uninjured. The advance of Gen. Fremont's main force as it entered Strasburg met the 1st New Jersey and the 1st Pennsylvania cavalry under Gen. Bayard, then just coming in, as a part of Gen. McDowell's force.

Meanwhile the force of Gen. Shields which had been ordered to cooperate, had left Massassas Junction, and halted at Haymarket on Tuesday, the 27th of May, as has been stated. On the 28th this division, followed by other troops from Gen. McDowell's corps, advanced as far as Rectortown, thirteen miles, having passed over steep and rocky roads through Thoroughfare Gap. On Thursday, the 29th, it started at five o'clock p. m., with orders to be in Front Royal, twenty-eight miles distant, on the next day at noon, at which time Gen. Fremont was to reach Strasburg. Their entire train was left behind and at the appointed time their advance brigade, under Gen. Kimball, struck the enemy at Front Royal, completely routing them and taking a number of prisoners and a large amount of commissary and quartermaster's stores. On the next day a party of eighteen cavalry entered the outskirts of Strasburg. Finding that the enemy had retired before Gen. Fremont, and that he was follow-

ing them, Gen. Shields moved up the east side of the Massanutten range of mountains to Luray, while Gen. Fremont advanced on the west side. Gen. Shields was in hopes of striking the enemy at New Market, but finding the Whitehouse and Columbia bridges burned, he resolved to push on further up the east side of the Shenandoah, to intercept the enemy at Conrad's Store (Miller's Bridge), Port Republic, or Waynesborough on the railroad eleven miles east of Staunton. Col. Carroll, in command of the 4th brigade, moved rapidly forward with one regiment, followed by the remainder of the brigade. A violent rain on the night of the 3d caused a delay, and various portions of the command were separated by rapid streams overflowing their banks. He, however, reached Port Republic in advance of the enemy.

At this time forces were gathering in other quarters. The 5th New York cavalry, Col. De Forrest, left Williamsport on Friday night, the 30th, at the time the attack at Harper's Ferry was made, and advanced to Martinsburg on Saturday morning, the 31st, and occupied the town. On the 2d of June Gen. Banks, having recrossed the Potomac, reached Bunker Hill, twelve miles from Winchester. Also by special train from Baltimore, Gen. Sigel arrived at Harper's Ferry on Sunday evening, June 1. During the next forenoon, he inspected the positions of the forces, and ordered a march at four o'clock in the afternoon. The next morning the advance of his division, consisting of Gen. Cooper's brigade, was beyond Charlestown, pushing forward to Winchester, where a junction was formed with Gen. Banks.

Meantime Gen. Fremont was in full chase of the swift-footed foe. Finding that the enemy had escaped him at Strasburg, and being joined by an advance of Gen. McDowell's, consisting of Gen. Bayard's cavalry, he ordered the cavalry and artillery to the front, and pursuit to be given.

A stand was made several times by the retreating enemy, during Monday, the 2d. A mile and a half beyond Strasburg, at a narrow and defensible pass called Fisher's Hill, the road, after crossing a bridge, turns abruptly to the right, and curving to the left passes the base of a thickly wooded hill with a deep ravine on the right, and continues up the hill through a deep and densely wooded defile. Here the first stand was made by the rear guard under Gen. Ewell. His artillery occupied elevated positions overlooking the road on his front for a mile, and commanding a range of hills adjacent to the road on the right of Gen. Milroy. Finding it to be impossible to drive the enemy's centre, Gen. Milroy chose other elevated positions for his guns on the right, and a fierce contest ensued for several hours. The enemy at night encamped three miles beyond Woodstock, while the forces of Gen. Fremont occupied the town.

The pursuit was commenced at seven o'clock

on the next morning, Tuesday, June 8. The advance to Edinburg was made without incident. A military bridge constructed by Gen. Banks across Stony Creek, a swift, wide stream, was half burned by the flying enemy. The delay in repairing the bridge and crossing gave the enemy time to move to Mt. Jackson, eight miles beyond Edinburg, where he halted until noon of the next day, the 4th, when he was again in motion, owing to the approach of Gen. Fremont's advance. One mile beyond Mt. Jackson, is a long bridge over the Shenandoah, a river too swift and deep to be forded. Gen. Jackson left his artillery in position long enough to delay the advance of Gen. Bayard's cavalry, then crossed the bridge before the guns of his pursuers could be brought up, and burned the bridge in face of their cavalry. The bridge was rebuilt by noon of the next day, the 5th, and the army of Gen. Fremont was again in motion. At three o'clock the advance entered New Market, a distance of seven miles, and encamped two miles beyond. On the 6th, Friday, the advance reached Harrisonburg about two o'clock P. M. None of the enemy were seen on the way. Almost every bridge, however small, was found to have been burned. Information was immediately received that a body of Confederate cavalry was near the town. Cannon were planted on the highlands north, and a force of cavalry, under Col. Wyndham, was sent out to reconnoitre, with instructions to engage the enemy if the force was only two or three companies, but not if it was in force and supported by infantry. Some three miles beyond the town, Col. Wyndham discovered the Confederate cavalry and made an effort to oppose them, but unfortunately came upon a large force of infantry, which opened such a volley upon him that his troops were thrown into confusion, and suffered severely, and he himself was taken prisoner. Later in the day Gen. Bayard and Col. Cluseret with a force of cavalry and infantry encountered the enemy. One regiment, the Bucktail rifles of Pennsylvania, numbering one hundred and twenty-five, under Col. Kane, suffered a severe loss of fifty-five men. This small force was rashly led against an overwhelming Confederate mass. The Union forces were finally withdrawn, and the enemy subsequently disappeared. Among the killed of the Confederate force was Col. Ashby, a brave and dashing cavalry officer. The forces of Gen. Fremont remained at Harrisonburg on Saturday, the 7th of June. A reconnoissance was made by Gen. Milroy, about seven miles on the road to Port Republic, where the enemy was found in a position well protected by woods. It seems that Gen. Jackson, before reaching the final bridge across the Shenandoah, determined to fight Gen. Fremont, and thereby check his pursuit. For this purpose he had chosen his position as above stated, at a spot called Cross Keys, near Union Church.

At six o'clock on Sunday morning, June 8, the army of Gen. Fremont began to move, and

at half past eight his advance opened upon the enemy. Gen. Fremont says:

"The battle began with heavy firing at eleven o'clock, and lasted, with great obstinacy and violence, until four in the afternoon, some skirmishing and artillery firing continuing from that time until dark."

The right wing was under Gen. Schenck, the left under Gen. Stahl, and the centre under Gen. Milroy. The right wing was not assailed, except by skirmish fighting. The contest was hot on the centre, and Gen. Milroy forced the enemy back from point to point. He had penetrated the centre, and almost reached the enemy's guns, when the order to retire was given. This filled him with indignation, but he obeyed.

Gen. Stahl's brigade was all engaged. Of this, the 45th New York and the 27th Pennsylvania first met the enemy, and being threatened by superior numbers, the 8th New York was sent to support them on the left, and the 41st New York on the right. These regiments were soon all engaged, and the enemy appeared to be bearing heavily upon this wing of the army. It finally gave way, and the whole line was ordered back to a more favorable position. The enemy did not advance, but commenced a retreat. The army encamped that night on the ground where their line was first formed in the morning. They drove the enemy's pickets and skirmishers over it at first, for no attempt was made on the other side to support them. The place where the fighting occurred, and the dead and wounded were strewn over the field, was in the enemy's possession all night.

The loss was very severe on both sides. In Gen. Stahl's command the loss was 69 killed, wounded 254, missing 79. The total loss was estimated by Gen. Fremont, immediately after the battle, at 125 killed and 500 wounded. The enemy's loss was less than this, owing to the shelter of their forces.

The despatch of Gen. Fremont to the War Department, dated on the next morning, says:

"There was no collision with the enemy after dark last night. This morning we renewed the march against him, entering the woods in battle order; his cavalry appearing on our flanks. Gen. Blenker had the left, Gen. Milroy the right, and Gen. Schenck the centre, with a reserve of Gen. Stahl's and Gen. Bayard's brigades."

Port Republic is a small town on the south fork of the Shenandoah river, near which is the bridge by which the river is crossed. It is a few miles distant from Cross Keys, where the conflict between Gens. Fremont and Jackson's forces took place. It has already been stated that Col. Carroll, in command of the advance of Gen. Shields's division up the east side of the Shenandoah, arrived at Port Republic in advance of Gen. Jackson. This means, in advance of the main force of the enemy. On Saturday, the 7th, Col. Carroll received orders to move forward to Waynesborough, distant some thirty-five or thirty-seven miles, by the

way of Port Republic, for the purpose of destroying the railroad depot, track, and bridge, at that place, and to seize Gen. Jackson's train and throw his force upon Gen. Jackson's flank. Col. Carroll marched in obedience to these orders, on Saturday afternoon. His infantry, cavalry, and artillery had in the mean time come up, and he started for Conrad's Store with less than a thousand of the former, with one hundred and fifty cavalry, and with a single battery of six guns.

Halting, in the night, six miles before reaching Port Republic, Col. Carroll sent forward a party of scouts, who returned with the information that Gen. Jackson's train was parked near Port Republic, with a drove of beef cattle herded near by, and the whole guarded by about two or three hundred cavalry. On learning this he pushed forward, with the design of capturing the train and cattle, as his orders directed. He halted some two miles from the town, made a reconnoissance, and received further information confirming the report of his scouts, and then dashed into the town with his cavalry and two pieces of artillery, driving the enemy's cavalry out and taking possession of the bridge. He halted there for his infantry to come up, and disposed his pieces and little force to prevent a repulse from the train guard, when, before he had occupied the village any length of time, he was attacked by a force of the enemy superior to his own, and forced to retire and abandon his further march to Waynesborough. Thus the enemy recovered possession of the bridge and held it.

Col. Carroll brought his forces to a stand at the first defensible position, about two miles north of the town. At this time the conflict was going on between Gens. Fremont and Jackson at Cross Keys, several miles distant, and it was over this bridge that Gen. Jackson must retreat or be placed between the forces of Gens. Fremont and Shields. At two o'clock in the afternoon Gen. Tyler arrived to the aid of Col. Carroll. As commanding one of the brigades of Gen. Shields's division, he had also been ordered to proceed to Waynesborough. He left Columbia Bridge on the 7th, and reached Naked Creek on the same day, and went into camp under orders to march at four A.M. When within six miles of Port Republic he learned of the engagement of Col. (acting brig.-gen.) Carroll, and pressed forward immediately with infantry and artillery to his support, and reached him at two P. M.

Gen. Tyler in his report thus explains his proceedings: "From Col. Daum I learned the enemy had eighteen pieces of artillery, planted so as to completely command all the approaches to the town, and from the engagement with Gen. Carroll that morning, had obtained the range of the different points. Immediately on the arrival of my command, Col. Daum urged an attack with the combined force of infantry and artillery, to which I so far consented as to order the infantry into position

under cover of a thick wood which skirted the road, and commenced observing the enemy's position myself, which appeared to me one to defy an army of 50,000 men. I at once sent for Col. Carroll, Lieut.-Col. Schriber, Capt. Clark and Robinson, who had been over the ground; they all agreed in the opinion that an attack would result in the destruction of our little force."

The infantry was ordered back to bivouac for the night, and early in the morning Gen. Tyler was informed that the enemy were advancing evidently with the intention of outflanking him on his left. Forces were ordered up to counteract this movement, which was successfully done. The enemy retired into the woods, and a part crossed over and joined the forces attacking the right wing. The engagement now became very heavy on the right, additional troops having been brought up on both sides. Under cover of this conflict, the enemy threw another force into the woods, pressed down upon the battery on the left, and with a sudden dash captured it. The contest continued until Gen. Tyler, perceiving additional reinforcements for the enemy approaching, about ten o'clock ordered his troops to fall back, with a view of retreating until he should meet reinforcements. The retreat, he says, "save the stampee of those who ran before the fight, was as orderly as the advance." The number of his force is stated at three thousand, and that of the enemy much larger. This was evidently the rear guard of Gen. Jackson's army, which had been engaged, and some reinforcements were sent back to it. Gen. Jackson retired from before Gen. Fremont on Sunday night, and on Monday morning crossed the bridge at Port Republic, and while the main body continued to retreat, Gen. Tyler was thus held in check.

Meanwhile Gen. Fremont, as has been stated, commenced his march for Port Republic that morning, with his army in battle array. During the afternoon his whole army reached the river opposite the town, and he learned that a portion of Gen. Shields's division had engaged the enemy on both Sunday and Monday on the other side of the river. During the march of Gen. Fremont's forces from the battle field of the preceding day to the river, they could hear brisk cannonading, and see the heavy volumes of smoke arising from the valley where the contest was going on. When they arrived the Confederate force was gone. Thus closed the pursuit of Gen. Jackson with a portion of the forces of four major-generals of the U. S. army on his line of retreat, beside those of Brig.-Gen. Shields. The loss of men on both sides occasioned by this expedition was not very great either in killed, wounded, or prisoners. No accurate details are at present accessible; but the destruction of Federal stores was vast.

On the night of the arrival of Gen. Fremont's forces at the river, an alarm was raised in camp. Horses were harnessed, and men placed

in a condition for an immediate movement, but affairs finally became quiet, and part of a night's rest was obtained. On the next morning, the 10th, orders to march were issued, and the army was soon in motion back to Harrisonburg, a distance of twelve miles, which it reached in a pitiless storm during the afternoon. On Wednesday it moved eighteen miles to New Market, and on Thursday reached Mt. Jackson, seven miles, and encamped for rest. Some forces of Gen. Jackson's army returned to Harrisonburg almost as soon as the Federal troops had left it. The division of Gen. Shields also fell back to New Market.

The force of Gen. Jackson was generally estimated by his opponents at twenty-five thousand men. The following regiments were included in it: the 1st, 2d, 10th, 13th, 21st, 25th, 31st, 33d, 37th, 42d, 52d, 57th, and 58th Virginia; the 6th, 8th, and 9th Louisiana; 1st Maryland; 21st North Carolina; 16th Mississippi, and 15th Alabama regiments of infantry, and the 2d regiment of Confederate infantry, and Major Wheat's battalion of Louisiana Tigers. The cavalry included the 2d, 6th, 7th Virginia, 1st Maryland, about twenty eight companies. The artillery exceeded thirty pieces in number.

The force of Gen. Fremont, on leaving Franklin, was stated to be about twenty thousand men. Throughout the entire period of this expedition the storms of rain were incessant, and the roads in an unusually bad condition.

A review of the facts thus stated shows that there was no concert of action between the forces actively engaged in the pursuit. The controlling head, the War Department, from which the orders to pursue issued, was too far distant from the scene of operations.

It should be stated in this connection, that on the very day on which Gen. Jackson attacked the 1st Maryland under Col. Kenly at Front Royal, the 23d of May, the Confederate General, Heath, in the western part of the Mountain Department, advanced rapidly and boldly with nearly three thousand men and attacked Col. Crook, acting brig.-gen., at Greenbrier Bridge, thirty-five miles from McDowell, and nine miles from Camp Alleghany. The command of Col. Crook consisted of the 36th and 44th Ohio and some batteries. The advance of Gen. Heath was met with so much vigor and promptness, that his forces were soon defeated, with the loss of his four pieces of artillery, and one hundred and fifty killed and wounded, and three hundred stand of arms, and a number taken prisoners. On his retreat, the Greenbrier Bridge was burned to check or prevent pursuit. This affair occurred on the day previous to the reception of the order by Gen. Fremont to march to the aid of Gen. Banks. The ill success of this enterprise was such that it failed to cause any diversion from Gen. Fremont's command.

This exploit of Gen. Jackson, undoubtedly one of the most brilliant and successful of the

war, if its objects are considered, introduced into the whole campaign in Virginia a disturbing element of considerable magnitude. It diverted large masses of men from movements designed to accelerate events on the peninsula, delayed the advance of Gen. McClellan, and deprived him of the reinforcements he expected. The time required for the transfer of troops in the South and Southwest, where the Confederate campaign had been a failure, to Richmond, the most important position of the Confederacy, was thus gained, and when Gen. McClellan was next prepared to move, he found the enemy in accumulating force in front of him.

On the 25th of May, Gen. McClellan issued a general order which was read throughout the camps, directing the troops as they advanced beyond the Chickahominy, to be prepared for battle at a moment's notice, and to be entirely unencumbered, with the exception of ambulances—to carry three days' rations in their haversacks, leaving their knapsacks with their wagons, which were on the eastern side of the river, carefully parked. Besides practical directions as to conduct, this order says to officers and soldiers: "Let them bear in mind that the Army of the Potomac has never yet been checked, and let them preserve in battle perfect coolness and confidence, the sure forerunners of success. They must keep well together, throw away no shots, but aim carefully and low, and above all things rely upon the bayonet."

The divisions from the corps of Gens. Heintzelman and Keyes were among the first to cross the Chickahominy. They took a position on the right bank somewhat advanced therefrom. The right wing rested near New Bridge, the centre at Seven Pines, and the left flank on the White Oak Swamp. Gen. Sumner's corps remained on the east side of the river. On the 30th, the Confederate Gen. Johnston made arrangements for an attack upon the Federal army, for the purpose of cutting off, if possible, the corps of Gen. Heintzelman and Keyes before they could be joined by Gen. Sumner. He selected the divisions of Gens. Longstreet, Huger, G. W. Smith, D. H. Hill, and Whiting. His plan was that Gens. Hill and Longstreet should advance by the road to Williamsburg and make the attack in front, and that Gen. Huger should move on the road to Charles City and attack in flank the troops assailed by Gens. Hill and Longstreet. Gen. Smith was ordered to the junction of the New Bridge road and the Nine Mile road, and to be in readiness to fall on the right flank of Gen. Keyes and to cover the left of Gen. Longstreet. The forces of Gens. Hill, Longstreet, and Smith were in position early on the morning of Saturday, May 31, and waited until afternoon for Gen. Huger to get into position. Prince de Joinville, who was a competent spectator, thus describes the scenes which followed this attack:

"At the moment it was thus attacked the



Federal army occupied a position having the form of a V. The base of the V is at Bottom Bidge, where the railroad crosses the Chickahominy. The left arm stretches toward Richmond, with this railroad and the road from that city to Williamsburg. There stood the left wing, composed of four divisions echeloned, one behind the other, between Fair Oaks and Savage stations, and encamped in the woods on both sides of the road. The other arm of the V, the right, follows the left bank of the river; that is the right wing. There are these five divisions and the reserve. Should one desire to communicate from one extremity to the other of those two wings, going by Bottom's Bridge, the way is very long, not less than 12 or 15 miles. In an air line the distance, on the contrary, is very trifling, but between the two arms of the V flows the Chickahominy. It was to connect both arms, in the space between them, that the construction of 3 or 4 bridges had been undertaken, only one of which was serviceable on the 31st of May. It had been built by Gen. Sumner, nearly halfway between Bottom's Bridge and the most advanced point of the Federal lines. It saved the army that day from a disaster." The other bridges were not ready. They were structures of logs, and time was required to build them. The approaches were always bad, and the tedious labor of corduroying long distances was necessary.

"It was against the left wing of the army that every effort of the enemy was directed. That wing had its outposts at Fair Oaks station, on the York river railroad, and at a place called Seven Pines, on the Williamsburg road. There the Federals had thrown up a redoubt in a clearing, where a few houses were to be seen, and constructed abatis, to increase the field for sharpshooting of the troops posted there. The rest of the country was completely covered with woods. The previous day there had been a frightful storm, with torrents of rain, and the roads were frightful.

"All at once, about one o'clock in the afternoon, the weather being dark and gloomy, a very spirited fusilade is heard. The pickets and sentries are violently driven in; the woods which surround Fair Oaks and Seven Pines are filled with clouds of the enemy's sharpshooters. The troops rush to arms and fight in desperation; but their adversaries' forces constantly increase, and their losses do not stop them. The redoubt of the Seven Pines is surrounded, and its defenders die bravely. Col. Bailey, of the artillery, among others, there upon his pieces finds a glorious death. In vain Gens. Keyes and Naglee exhaust themselves in a thousand efforts to keep their soldiers together: they are not listened to. In this moment of confusion they perceive a little French battalion, known as the Garde Lafayette, which has remained in good order. They rush to it, place themselves at its head, charge the enemy and retake a battery. The battalion loses a

fourth of its men in this charge; but, like true Frenchmen, always and everywhere the same, they cry, "They can call us the Garde Lafourchette now?" alluding to an offensive nickname that had been given them.

"Meanwhile Heintzelman rushes to the rescue with his two divisions. As at Williamsburg, Kearney arrives in good time to reestablish the fight. Berry's brigade, of this division, composed of Michigan regiments and an Irish battalion, advances firm as a wall into the midst of the disordered mass which wanders over the battle field, and does more by its example than the most powerful reinforcements. About a mile of ground has been lost, fifteen pieces of cannon, the camp of the division of the advanced guard, that of Gen. Casey; but now we hold our own. A sort of line of battle is formed across the woods, perpendicularly to the road and the railroad, and there the repeated assaults of the enemy's masses are resisted. The left cannot be turned, where is the White Oak Swamp, an impassable morass; but the right may be surrounded. At this very moment, in fact, a strong column of Confederates has been directed against that side. If it succeeds in interposing between Bottom's Bridge and the Federal troops, which hold beyond Savage's Station, the entire left wing is lost. It will have no retreat, and is doomed to yield to numbers; but precisely at this moment—that is to say, at 6 o'clock in the evening—new actors appear on the scene. Gen. Sumner, who has succeeded in passing the Chickahominy, with Sedgwick's division, over the bridge constructed by his troops, and who, like a brave soldier, has marched straight through the woods to the sound of the cannon, arrived suddenly on the left flank of the column with which the enemy is endeavoring to cut off Heintzelman and Keyes.

"He plants in the clearing a battery which he has succeeded in bringing with him. They are not those rifled cannon, the objects of extravagant admiration of late, good for cool firing and long range in an open country: these are the true guns for a fight—twelve-pound howitzers,\* the old pattern, throwing either a round projectile, which ricochets and rolls, or a heavy package of grape. The simple and rapid discharging of these pieces makes terrible havoc in the opposing ranks. In vain Johnston sends against this battery his best troops, those of South Carolina—the Hampton Legion among others. In vain he rushes on it himself; nothing can shake the Federals, who, at nightfall, valiantly led by Gen. Sumner in person, throw themselves upon the enemy at the point of the bayonet, and drive him furiously, with frightful slaughter and fear, back as far as Fair Oaks Station.

"Night put an end to the combat. On both sides nothing was known of the result of the battle but what each one had seen with his

\* They were "Napoleon" guns.—[En.]

own eyes. Friends and enemies, lost in woods they were unacquainted with, lay down amid heaps of dead and wounded, wherever darkness overtook them. The fatigue of this obstinate struggle as well as the obscurity of the night had imposed on the combatants one of those tacit truces so frequent in war.

"Evidently Johnston had flattered himself, in throwing all his forces on the four divisions of the left wing, that he could annihilate them before any aid could come to them from the main body of the army on the left bank of the Chickahominy. For the moment he had recoiled before the energetic resistance of those four divisions, and also before the furious and unforeseen attack of Sumner's troops. No doubt he had counted on the terrible storm of the previous day to have swelled the Chickahominy so as to render the establishment of a bridge impossible, or to sweep away in its overflowing waters those already established; but the capricious river baffled his plans, as it did some hours later those of his adversaries. The effect of the deluge was not immediate; the rise in the water delayed its appearance 24 hours. Was this un hoped-for delay turned to account with all desirable activity on the part of the Federals? That is a question which will remain always in dispute, as are so many others of the same kind, which form one of the necessary chapters of the history of most great battles.

"It was only at one o'clock in the afternoon that the action had commenced. We had waited some time to ascertain if the attack on that side was not a feint, intended to draw the Federal troops to that point while the bulk of the enemy's forces was hastening to debouch on the left bank. We had been promptly relieved of our uncertainty by the violence of the attack and by the reports of the aeronauts, who saw the entire Confederate army marching to the point of attack.

"Then Sumner had received orders to cross the water with his two divisions. He had executed the movement with rapidity, marching at the head of his column, without any other guide than the sound of the cannon, and he arrived at the right moment and at the critical place. But some persons thought then, and still think, that if, at the moment Sumner received the order to cross the river, the same order had been given to all the divisions of the right wing, it would have been practicable. We fancy what might have happened if, in place of throwing 15,000 men on Johnston's flank, 50,000 had been thrown. Sumner's bridge, doubtless, would not have answered for the crossing of so many. At midnight the tail end of his column was still crossing, struggling against all the difficulties which bridges formed of trunks of trees that turn under the feet, muddy sloughs and a dark night—the darkness rendered still deeper by the thickness of the woods—present to horses and artillery. Several bridges were, however, ready to be thrown

across at other points. It was necessary to work without a moment's loss to construct them, and not be disturbed by the obstacles the enemy would not have failed to present to the undertaking. A brigade was displayed for full effect and scarecrow fashion, opposite the points naturally marked out for crossing; but the stake was so large, the result so important, and the occasion itself so unforeseen and so favorable for playing a decisive part, that nothing, in our opinion, should have prevented that operation from being attempted.

"Here, again, was evident that American slowness which belongs much more to the character of the army than that of its chief. It was not until 7 o'clock in the evening that the idea of securing all the bridges without delay, and causing the whole army to cross at day-break to the right bank of the Chickahominy, was entertained.

"It was now too late. Four hours had been lost, and the opportunity—that moment so fleeting, in war as in other circumstances—had gone. The rise, on which Johnston had vainly counted, and which had not hindered Sumner from crossing, came on during the night. The river rose suddenly from two feet, and continued to swell with rapidity, carrying away the new bridges, tearing up and sweeping off the trees which formed the planking of Sumner's bridges, and covering the entire valley with its overflowing waters. Nothing could cross.

"At the earliest dawn of day the combat was resumed with great fury on the left bank. The enemy came on in a body, but without order or method, and rushed upon the Federals, who, knowing that they were inferior in numbers and without hope of being supported, did not attempt to do more than resist and hold their ground. They fought with fierce determination on both sides, without any noise, without any cries, and whenever they were too hardly pressed they made a charge with the bayonet. The artillery, placed on the eminences in the rear, fired shell over the combatants. Ah! I could have wished that all those who, forgetful of the past, and impelled by I do not know what kind of egotistical calculation, have lavished their encouragement on the fatal rebellion of slaveowners, could have been present at this fratricidal struggle. I could have wished them, as a punishment, a sight of this terrible battle field, where the dead and dying were piled up by thousands. I wished that they could have seen those temporary ambulances formed around the few habitations found here and there. Oh! what misery—oh! what suffering! The ambulances had something about them particularly horrible. The houses were altogether too few to contain the smallest proportion of the wounded, and they were therefore compelled to lay them outside; but although they did not make any complaints, and bore their fate with the most stoical courage, their exposure in one position beneath the rays of the sun of the middle

of June soon became intolerable. They were then to be seen putting forth all their remaining strength, and crawling to seek a little shade. I will always remember a bed of roses, whose sweet-scented flowers I was admiring while conversing with one of my friends, when he drew my attention to one of these unfortunate men, who had just died beneath its bushes. We looked at each other without saying a word, the heart being oppressed with the most painful emotion. Mournful scenes, from which the pen of the writer, like the eye of the spectator, hastened to turn away.

"Toward midday the fire gradually diminished, then ceased. The enemy retreated; but the Federals were not in a position to pursue them. No one then knew what a loss the Southerners had just suffered in the person of their commander, Gen. Johnston, who was severely wounded. It was to his absence that was owing, in a great measure, the unskillful attacks against the Federal army in the morning. When the firing ceased at midday, the Confederates, tired of the prolonged strife which they had been sustaining, and being no longer commanded, were, it is said (for in the midst of these immense woods one sees nothing, and is compelled to guess everything), in a state of inextricable confusion. Who can say what would have been the result if at this moment the 85,000 fresh troops left on the other side of the Chickahominy had appeared on the flank of this disordered mass after having successfully crossed the bridges?

"Such is the history of this singular battle, which, although complicated by incidents superior to human will, must not be taken otherwise than as a type of American battles. The conflict was a bloody one, for the North had lost 5,000 men, the South at least 8,000; but the results were barren on one side as on the other. Although the losses of the enemy were much greater than those of the Federals, the result was especially distressing to the latter. They had lost a rare opportunity of striking a decisive blow. These occasions did not return, and therefore, in the circumstances in which they were placed, the result was against them."

The crossing of Gen. Sumner's corps commenced about four o'clock in the afternoon. At that time the head of the advance, Gen. Gorman's brigade, turned from the swamps on the left bank of the river to cross by the bridge built by Gen. Sumner,—a battery moved next, then Gen. Burns's brigade, then artillery, and finally Gen. Dana's brigade, all of Gen. Sedgwick's division. In consequence of the morasses, all the batteries except Kirby's were left behind; but all the troops except the 19th Massachusetts, which was detached to assist the artillery, were moved swiftly onward to the scene of action. Gen. Richardson's division was detained until quite late in the evening by the obstructed causeway. At seven o'clock, it was in the position to which it had been assigned. It took no part in the battle on Saturday.

Now was the time to capture the city. The retreat of the army caused great consternation at Richmond. The Confederate force had retired in confusion, and if they had been sharply followed up, the gates of the city would have been reached, if friend and foe had not gone in together. It is useless to speculate on possibilities. The force with which Gen. McClellan commenced his march had been diminished before Yorktown and Williamsburg, and by constant skirmishing. It garrisoned Yorktown and Williamsburg, and occupied the White House, and the line of the railroad. It had received no reinforcements up to this time except the division of Franklin. It was also impossible for him to move the corps of Generals Porter and Franklin over the Chickahominy at the decisive moment, as even the bridge on which Gen. Sumner had crossed had been so far destroyed by the river, which was swollen by the rains of Friday and Saturday, that it was impassable for a single horseman. The three corps which had been engaged in the battles of Saturday and Sunday were too much cut up and wearied, by their conflict with superior numbers, to be able to pursue the retreating Confederates, particularly as they might probably have been met at the outworks of the city by fresh troops, in numbers fully equal to themselves, and a strong artillery in position. He was in no condition to risk anything. He had fought the enemy in equal or superior numbers, and they had retired in confusion. The corps of Gen. McDowell, if on hand now, might have taken Richmond, but without it the commanding general was not strong enough to risk its immediate attack. There were other considerations to govern his conduct. He was leading an invading army without reserves to fall back upon. A repulse would have ended in serious, if not complete disaster. Such a result to the peninsular campaign would have been fatal to the cause to which the Army of the Potomac was devoted. It would have convinced foreign powers that there was such a degree of military strength in the Confederacy as to render the immediate recognition of its independence both safe and politic. But there was probably one consideration which outweighed all others, and exerted a decisive influence upon the movements. This was the certain and safe reception of sufficient supplies. The single line of railroad was not capable of transporting them. The horses were kept on half forage, and if the distance had been increased, the army itself would have suffered. What hope was there of holding Richmond, even if it had been taken, with a line of transportation not capable of bringing forward sufficient to sustain the army, and one which, from the inadequate force to guard it, was liable at any moment to be broken up? Finally, for many days after the battle, the fields and roads were in such condition as to render it impossible to move any amount of artillery over them. To have advanced without

it would have placed infantry in front of works armed with heavy guns.

The danger of his position was soon demonstrated to the commanding general. It was determined in Richmond at this time, to penetrate the lines of the Federal army, and make a full and thorough reconnoissance of its position and strength. For this purpose, early on the 8th of June, Gen. J. E. B. Stuart, with the 1st, Col. Fitz Hugh Lee; 9th, Col. F. H. Fitz Hugh Lee; and 4th Virginia cavalry, Lieut. Gardner; the Jeff. Davis troop, with two pieces of flying artillery, a 12-pound howitzer, and a 6-pound rifled English piece, numbering about fifteen hundred men, left Richmond and proceeded down the Charlottesville turnpike. That night they encamped at Ashland, not deeming it safe to proceed after dusk, and communicated by signal rockets with Richmond. As soon as day dawned, they proceeded carefully and cautiously, and penetrated the Federal lines. Near Hanover Court House, two or three small bodies of Federal cavalry were met, and skirmishing ensued, but the latter, being unable to withstand the heavy Confederate force, were quickly routed. The camps of these Federal outposts were visited and destroyed; wagons on the road were overtaken and burnt, and the entire route from Ashland by Hanover Court House to Tunstall's Station, on the York River railroad, was to this force a continuous scene of triumph and destruction. Commissary and quartermasters' stores were seized and burned; prisoners and horses were taken and sent to the rear. The amount of property destroyed, however, was very small.

Upon approaching the railroad, cars were heard advancing, and the whistle sounded. By orders, every man was instantly dismounted and ranged beside the track. Thinking the force to be a friendly one, the train was stopped, when one company of the troop opening fire, disclosed its character. The train was immediately started under full steam for the Chickahominy, and despite logs placed on the track, made its escape. It consisted chiefly of uncovered platform cars, on which were some soldiers who were fired upon and killed or wounded. A detachment was immediately sent toward the White House on the Pamunkey river, where a number of wagons loaded with stores, and four transport vessels were found. Two of the vessels with their stores were destroyed, and a few wagons at Garlick's Landing. New Kent Court House was made the rendezvous whither the main body had gone, and where they were soon joined by this detachment. Here a halt was made until midnight. Some prisoners were taken, and sutlers' stores consumed or destroyed. At midnight they quietly moved by a lonely road toward the Chickahominy, and passing near a considerable body of the Federal forces, they reached its banks a little before dawn on Sunday, the 11th, and were ready to cross. They had arrived

far below the bridges, and where deep water flows, and knew not how to cross. Their perplexity is thus described by a Confederate writer: "Here was an awful situation for a gallant band! Directed to Blind Ford, it was fifteen feet deep! The enemy had blocked up all the main roads, and had thousands scouring the country, eager to entrap or slaughter it. And without means to cross! Quietly taking precautions against all surprise, strict silence being enjoined upon the prisoners, first one horseman plunged into the flood, and then another at different points—all too deep; no ford discoverable, no bridge! The horses, it was thought, would follow each other, and swim the stream—it was tried, and the horses carried away by the current! Breaking into small parties, the cavalymen swam and reswam the river with their horses, and when some fifty or more had been landed, a strange but friendly voice whispered in the dark, 'The old bridge is a few yards higher up—it can be mended!' 'Twas found, and mended it could be! Quietly working, tree after tree was felled, earth and twigs and branches were carried and piled up on the main props; old logs were rolled and patched across the stream; yet after long and weary labor the bridge was built, and the long and silent procession of cavalry, artillery, prisoners and spoils, safely and quietly passed this frail impromptu bridge, scarcely any sounds being heard but the rush of waters beneath. Once across and in the swamps, all was industry and expedition. Artillery axles sank low in the mire—ten Yankee horses were hitched to each piece, and as the first rays of morning crimsoned the tree tops, the long line rapidly sought the shade of woods away from the Federal lines. Yet the troops had not proceeded far when the advance was halted. 'Who comes there?' cried the Federal horsemen in the swamp. 'Who goes there?' calls another, and quicker than thought the advance guard dashes away into the open ground; the Federals fire half a dozen shots, and rush in pursuit. Into the thicket some half dozen Federal horsemen dart and are surrounded and made prisoners."

The crossing was made thirteen miles from Gen. McClellan's headquarters, and five miles from his pickets. They were now soon within the lines of the Confederate army. The delay caused by the vigorous skirmishing with the enemy encountered, caused them afterward to make so much haste to escape, that the amount of property destroyed was small, and estimated at fifty thousand dollars. Three hundred mules and some prisoners were taken away. This small force of the enemy's cavalry had passed entirely round and in the rear of the Federal army. The hope for the cooperation of Gen. McDowell amid these perilous scenes was again, for the third time, now rekindled in the mind of Gen. McClellan, and not entirely in vain. On the 10th of June, Gen. McDowell wrote as follows:

June 10, 1862.

*Maj.-Gen. G. B. McClellan, Commanding Department of Virginia, before Richmond :*

For the third time I am ordered to join you, and hope this time to get through. In view of the remarks made with reference to my leaving you and not joining you before, by your friends, and of something I have heard as coming from you on that subject, I wish to say I go with the greatest satisfaction, and hope to arrive with my main body in time to be of service. McCall goes in advance by water. I will be with you in ten days with the remainder by Fredericksburg.

IRVIN McDOWELL,  
Major-General Commanding.

On the 12th, he again wrote, as follows:

HEADQUARTERS DEPARTMENT OF THE RAPPAHANNOCK, }  
MANASSAS, June 12, 1862. }

*Maj.-Gen. G. B. McClellan, Commanding Department of Virginia, before Richmond :*

The delay of Maj.-Gen. Banks to relieve the division of my command in the valley beyond the time I had calculated on, will prevent my joining you with the remainder of the troops I am to take below at as early a day as I named. My third division (McCall's) is now on the way. Please do me the favor to so place it that it may be in a position to join the others as they come down from Fredericksburg.

IRVIN McDOWELL,  
Major-General Commanding.

Contrary to the expectation of both, the division of Gen. McCall was the only one of Gen. McDowell's corps which subsequently reached the army of the Potomac.

On the next day after the battle of Fair Oaks, above described, Gen. McClellan recovered without resistance the stations of Fair Oaks and Seven Pines, and the two armies were once more in the same position as before.

On the 2d of June President Davis issued the following address to the Confederate army:

EXECUTIVE OFFICE, June 2, 1862.

*To the Army of Richmond :*

I render to you my grateful acknowledgments for the gallantry and good conduct you displayed in the battles of the 31st of May, and the 1st instant, and with pride and pleasure recognize the steadiness and intrepidity with which you attacked the enemy in position, captured his advanced intrenchments, several batteries of artillery, and many standards, and everywhere drove them from the open field.

At a part of your operations it was my fortune to be present. On no other occasion have I witnessed more of calmness and good order than you exhibited while advancing into the very jaws of death, and nothing could exceed the prowess with which you closed upon the enemy when a sheet of fire was blazing in your faces.

In the renewed struggle in which you are on the eve of engaging, I ask and can desire but a continuance of the same conduct which now attracts the admiration and pride of the loved ones you have left at home.

You are fighting for all that is dearest to men; and, though opposed to a foe who disregards many of the usages of civilized war, your humanity to the wounded and the prisoners was the fit and crowning glory to your valor.

Defenders of a just cause, may God have you in His holy keeping!

JEFFERSON DAVIS.

Gen. McClellan now set to work to complete in a substantial manner the bridges across the Chickahominy and put the two wings of his army in communication with each other in spite of any inundations. Entrenchments were then thrown up along the whole line. The right wing, consisting of the divisions of Gens. McCall, Morrell, and Sykes, was posted on the

left bank of the Chickahominy from Beaver Dam Creek to a point below New Bridge. The centre, consisting of Gens. Smith's, Sedgwick's, and Richardson's divisions, was stretched in a line from Golding on the right bank of the river to a point south of the York river railroad. The left wing, consisting of Gens. Hooker's, Kearney's, and Couch's divisions, extended from the left of Gen. Richardson's position to a point considerably south of the Williamsburg stage road, on the borders of White Oak swamp. The Confederate line pressed so close to the Federal line on the right bank of the river that neither could advance a regiment outside their respective breastworks without provoking a contest. In this position the two armies remained until near the close of the month.

The demonstration in the rear of the Federal army had convinced the commanding general that a change of position might become necessary, and some vessels loaded with ammunition, provisions, and other supplies were wisely sent to James river near City Point, but no further steps for this purpose were taken.

On Wednesday, the 25th of June, the first movement on the part of Gen. McClellan was made. This consisted in directing Gen. Hooker to take up an advanced position of a mile on Fair Oaks farm, near the Williamsburg road leading directly to Richmond. It was calculated that this movement might be followed by a general resistance on the part of the Confederates, which would renew the battle of Fair Oaks, and by the advantage of the bridges the whole army could be concentrated. If the battle was not renewed then it would be one step in advance toward Richmond. The ground Gen. Hooker was ordered to occupy was taken, lost and retaken with a loss of from four to five hundred men. He was ably supported by Brig.-Gens. Grover and Sickles. During the ensuing night information was received that Gen. Jackson, returned from the Shenandoah Valley, was in force near Hanover Court House. This indicated that the Confederate army had now been concentrated, and the object of Gen. Jackson in that position was to attack the Federal communications, and cut them off by seizing the York river railway in their rear. The advance upon Richmond could not therefore be further prosecuted by the diminished forces of the Federal army. Gen. Hooker was consequently recalled from his advanced position on the next day.

It appears that on the 25th a council of all the Confederate generals was held at Richmond. Gens. Lee, Baldwin, Jackson, A. P. Hill, D. H. Hill, Hunger, Longstreet, Branch, Wise, Anderson, Whiting, Ripley, and Magruder were present. It was determined that Gen. Jackson should move upon the right flank of the Federal army, and if Gen. McDowell remained inactive in his position near Fredericksburg, then a general and simultaneous attack was to be made upon the whole line of Gen. McClellan.

A demonstration along the Richmond road made at that time by Gen. McDowell would have rendered the flank march of Gen. Jackson entirely impracticable. This demonstration was feared by Gen. Lee; but he was unaware that it had then been determined at Washington to concentrate the corps of Gen. McDowell with the other forces before Washington and form the army of Virginia under Gen. Pope. The order for that purpose was issued on the 27th, at Washington, the 2nd day after the council of officers at Richmond; and thus prevented entirely the movement feared by Gen. Lee. (See page 126.)

On the 26th Gen. Jackson reached Ashland, there to commence his flanking operations. His advanced guard drove in the little Federal force posted there and pushed on without loss of time to Hanover Court House, where he threw forward Gen. Branch's brigade between the Chickahominy and the Pamunkey rivers to establish a junction with Gen. Hill, who was to cross the former stream at Meadow Bridge. It was the movement of Gen. Hill's troops, seen pouring out of Richmond by the Federal army, in the direction where Gen. Jackson was known to be, which convinced them of the serious work at hand on their right. Gen. D. H. Hill began his offensive operations about 1 p. m. by an attack upon Mechanicsville and met with a brave resistance. Gen. McCall's Pennsylvania reserves were stationed there supported by Gen. Morrell and Gen. Sykes, and strongly entrenched for defence. Storming attacks were made again and again with fury, and were as often repelled with a cool determination. In vain Gen. D. H. Hill sent his aids in quest of Gen. Branch. The latter did not arrive until night, when the conflict had ended.

At this time eight divisions of the Federal army were on the right bank of the Chickahominy occupying entrenchments fronting Richmond. Before these troops lay the mass of the Confederate army also in entrenched positions. Upon the left bank of the river connected by numerous bridges was Gen. Fitz-John Porter with two divisions and Gen. Sykes' regulars. It was against this latter force that the Confederate attack was made. Two separate armies of great force were thus about to attack Gen. McClellan, and his position was extremely critical. If he concentrated on the left bank of the Chickahominy, he abandoned the attempt to capture Richmond, and risked a disastrous retreat upon the White House and Yorktown with the entire Confederate army in pursuit, and where he could hope for no support. If he moved to the right bank of the river, he risked the cutting off of his communications with the White House by the enemy, who might seize the railroad over which his supplies came. He would then be forced to open new communications with James river, and move at once in that direction. There he would receive the support of the navy, and if reinforced could operate against Richmond or

Petersburg, the fall of the latter place involving the fall of the former. This latter movement had been thought of some time previous, and transports, with a prudent foresight, had been sent to the James river. It was now determined upon. The distance from Fair Oaks to the James river was about seventeen miles. A single road only existed by which the baggage and stores could be moved. This was exposed in front to the enemy, who, by several roads radiating from Richmond, could throw a considerable force at once upon different points. The activity with which this movement was performed was such that it was nearly completed before it was anticipated by the enemy.

During the night in which Gen. D. H. Hill was held in check at Mechanicsville, the whole of Gen. Porter's baggage was sent over to the right bank of the river and united with the long train which was to set out on the evening of the 27th for James river. At the same time orders were given to reship or destroy all the stores along the railroad to White House and to evacuate that depot. This duty was assigned to Gen. Stoneman with a flying column. He was also ordered to delay the advance of the enemy and to fall back after the execution of these orders on Yorktown. All this was successfully done.

For the next day, Friday, the 27th, the orders to Gen. McCall on the extreme right were to fall back on the bridges thrown across the Chickahominy at Gaines's Mill. Joining the other troops of Gen. Porter's corps, consisting of the division of Gen. Morrell and the regulars of Gen. Sykes, their duty was to make a stand in front of the bridges in order to give the army time to execute its general movement. Gen. Porter, with this force, was not to cross the bridges until evening, and then to destroy them. The manner in which these orders were executed will now appear.

Scarcely had the morning of the 27th dawned, when the Confederate forces, under Gen. D. H. Hill, that had been held in check the previous evening, opened a tremendous fire of artillery upon the front of Gen. McCall, who, upon seeing the brigade of Gen. Branch, ordered on the previous day to support Gen. Hill, advancing to attack his right, began to fall back, fighting, further down the stream. This secured the crossing of the Chickahominy at Mechanicsville to the Confederates, and the first reinforcements ordered from their main body during the night, consisting of the veteran corps of Gen. Longstreet, and the division of Gen. A. P. Hill, now arrived. An order to advance was now given all along the Confederate line, except the right wing under Gen. Magruder, which now confronted Gen. McClellan on the right bank of the Chickahominy. The divisions of Gens. A. P. Hill, Anderson, and Whiting formed the centre, and moved toward Coal Harbor, while Gens. Jackson, D. H. Hill, and Longstreet formed the left nearer the Pamunkey river. Apprehensions were still entertained by Gen.

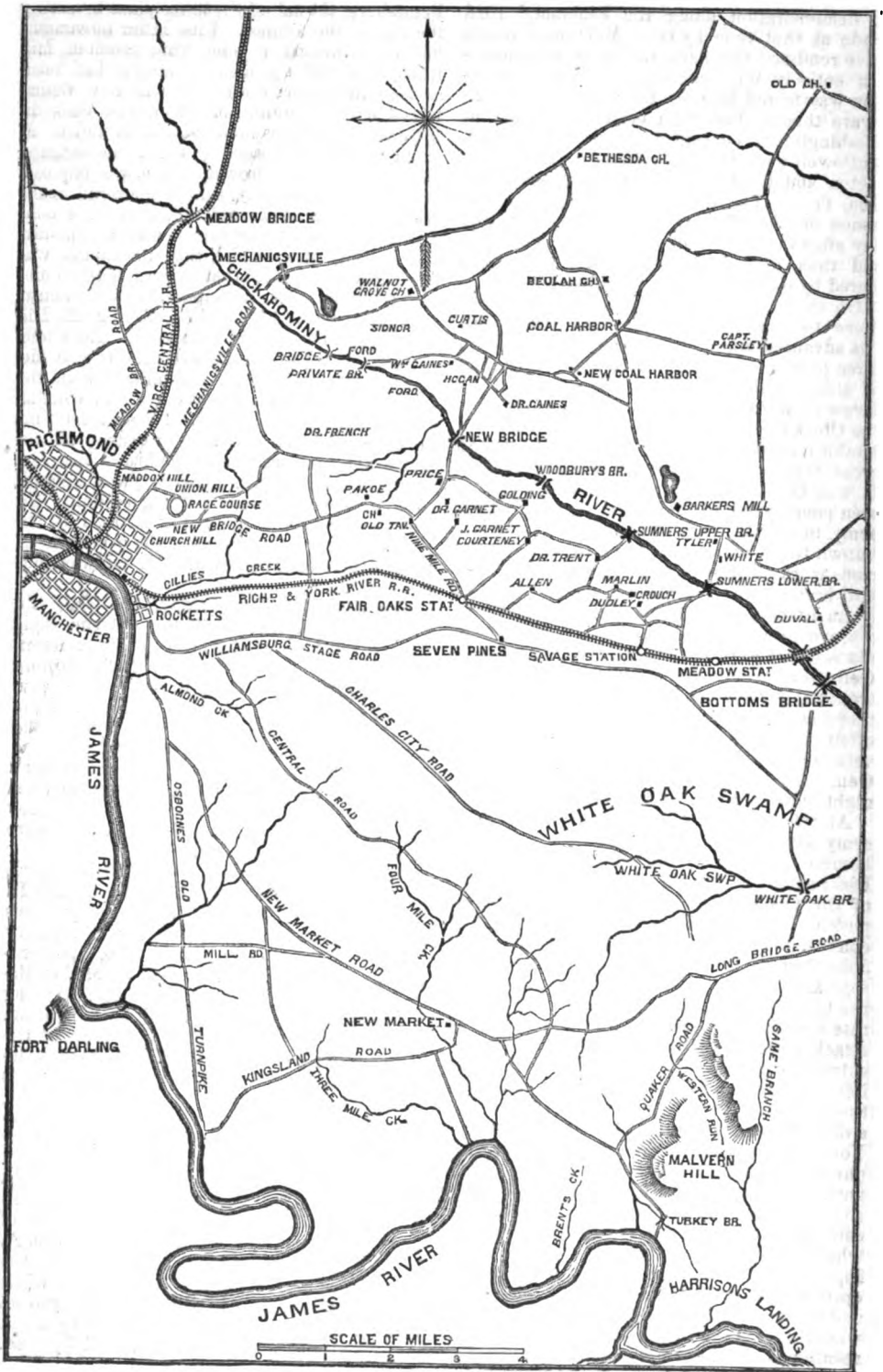

Lee of the approach of Gen. McDowell, and it was not until he received reliable intelligence of the latter's inactivity that he resolved upon a general attack. As soon, therefore, as he was informed that Gen. Jackson had reached Coal Harbor, steps were taken for an immediate attack on the retiring corps of Gen. Porter, which was supposed to be the mass of Gen. McClellan's army, and which had taken up the position it was ordered to hold on the left bank before the bridges. The Confederate attack was opened by the columns of Gen. D. H. Hill, Anderson, and Pickett. These brave masses rushed with "thundering hurrahs" upon the musketry of Gen. Porter's corps, and whole ranks went down under the terrible fire that met them. After a fierce struggle the Confederate troops began to give way, and at length all orders and encouragements were vain. They were falling back in the greatest disorder. Immediately Gen. Cobb appeared on the field with his legion, and the 19th North Carolina, and 14th Virginia, and renewed the attack, but all their efforts were in vain. Broken to pieces and disorganized, the fragments of that legion came rolling back from the charge. The 19th North Carolina lost eight standard bearers, and most of their officers were either killed or wounded. The shattered regiments of Gens. Hill and Anderson were again led up, but their foes quietly and coolly held out against every attack that was made. During this moment of success for the Federal army, Gen. McClellan hastened to throw upon the left bank all the troops not absolutely necessary to guard the lines in front of Richmond. It was nearly night when some of the divisions reached the river, and at this time the Confederate left and reserves had been brought up. The weight of their attack was made on the Federal left, where the troops had sustained an unequal fight all day, and were worn out, having fired almost their last cartridge. The left gave way and disbanded. This disorder extended until it reached the centre of the Federal lines, which fell back in increasing confusion, until the fresh brigades of Gens. Meagher and French were met. The vigorous shouts of these troops, and the placing a few guns anew in battery and opening fire served to check the enemy, who paused at this final determination, and darkness closed the contest at Gaines's Mill.

The left wing, under Gen. Porter, subsequently supported from the main body, had accomplished the purpose of holding the Confederates in check, and that night the train of five thousand wagons, the siege train, a herd of twenty-five hundred oxen, and other material was in motion for James river. During the night the troops of Gen. McClellan repossessed the bridges of the Chickahominy in perfect order, destroying them after they had passed. The field of battle, with the dead, and those most seriously wounded, a few guns and some prisoners, was abandoned. The corps of Gen. Keyes in the advance toward James river took

possession of the road across the White Oak Swamp, and the principal lines of communication by which the Federal army could be annoyed by their enemies.

Meantime the Confederate officers and men supposed, from the manner in which the day closed, leaving them in possession of the field of battle and its spoils, that Gen. McClellan was completely cut off from his base of retreat. The capture or destruction of the entire Federal army was regarded as certain. The rejoicing bordered on frenzy. Their demonstration on the 28th was made to the White House, where the immense stores which were expected to fall into their hands were found to have been destroyed, and nothing but ruins remained. The burial of the dead, and the care for the wounded, and repose for the troops, and uncertainty as to the position of the Federal army, caused the day to pass without any movement of the Confederate troops. The mass of them were now on the left bank of the Chickahominy, over which the bridges had been destroyed, while Gen. McClellan's army united was on the right bank. Time now was worth everything to them. Before they could be attacked, however, it was necessary for the Confederate force to rebuild the bridges, or to fall back some distance to the Mechanicsville bridge. It was not until the reports of the state of affairs at the White House were made in the afternoon of the 28th, and the statements of prisoners, that Gen. Lee comprehended the real movements of Gen. McClellan, and that he was on his way to James river to form a junction with the fleet. The twelve brigades of Gens. D. H. Hill and Longstreet were instantly put in motion to give the death blow to the enemy, whom they supposed now to be flying.

The position of Gen. McClellan on Saturday night was such that the Confederate officers, who were unaware of his design, were confident of his capture. Having abandoned, and, as they supposed, been driven from all his strongholds on the north side of the Chickahominy, cut off from all communication with his supplies at the White House, and with the Chickahominy in his rear, and the divisions of Gens. Longstreet, Magruder, and Huger in his front, all hopes of his escape were thought to be impossible.

The morning of the 29th was spent by Gen. McClellan's troops in destroying all that could not be carried away from the camps. A complete railroad train, locomotive, tender and cars, which had been left on the track, was sent headlong over the broken bridge into the river. Nothing was left but three siege guns which could not be moved.

The corps of Gens. Sumner and Franklin had been left in the works at Fair Oaks with instructions to evacuate and protect the baggage and supply trains on their way to the river. Hardly had they commenced to fall back on the railroad and Williamsburg turnpike, when the enemy, perceiving the movement, pressed forward, giving the former barely time to place



their men in position. The attack was commenced by the Confederates about two o'clock p. m., about one mile and a half above Savage's Station, and the conflict continued until near night. The enemy, advancing in solid masses to within a short distance of the artillery, suffered severely and were repulsed. During the night Gens. Sumner and Franklin fell back to White Oak Swamp bridge.

On the morning of Monday, the 30th of June, all the troops and all the trains were in safety beyond White Oak bridge, which presented a new obstacle to the Confederates. Gens. Sumner and Franklin were left to act as a rear guard, and hold the passage of the White Oak Swamp, whilst Gens. Heintzelman, with the divisions of Gens. Hooker, Kearny, Sedgwick, and McCall, were placed at the point of intersection of the roads leading from Richmond, called Charles City cross roads. These movements protected the trains until they arrived at the James river, precisely at the time when the transports with provisions and ammunition and hospital stores arrived from Fortress Monroe.

The advance of the Confederate force was actively resumed early in the morning. Gens. D. H. Hill, Whiting, and Ewell, under the command of Gen. Jackson, crossed the Chickahominy by the Grapevine bridge, and followed the Federal retreat by the Williamsburg road and Savage's Station. Gens. Longstreet, A. P. Hill, Huger, and Magruder took the Charles City road with the intention of cutting off the Federal retreat. At the White Oak Swamp the left wing under Gen. Jackson came up with the Federal force under Gens. Franklin and Sumner, about 11 a. m. They had crossed the stream and burned the bridge behind them. An artillery fire was opened upon both sides, which continued with great severity and destruction until night. The result of this battle was to prevent the further advance of the enemy in this direction, which was the single line of road over which the trains had passed.

Late on the same day, a battle was fought between the forces under Gen. Heintzelman and the main force of the enemy, which attempted to advance by the Charles City road to cut off the retreat. This force was led by Gens. Longstreet, A. P. Hill, and Huger. The former, however, being called away, the command devolved upon Gen. Hill. As the masses advanced upon the Federal batteries of heavy guns they were received with such a destructive fire of artillery and musketry as threw them into disorder. Gen. Lee sent all his disposable troops to the rescue, but the Federal fire was so terrible as to disconcert the coolest veterans. Whole ranks of the Confederate troops were hurled to the ground. Says an actor in the conflict, "The thunder of the cannon, the cracking of the musketry from thousands of combatants, mingled with the screams of the wounded and the dying, were terrific to the ear and to the imagination." The conflict thus continued within a narrow space for hours, and not a foot

of ground was won by the Confederates. Night was close at hand. The Federal lines were strengthened and the confidence of the Confederate general began to falter. The losses of his exhausted and worn out troops in attempting to storm the batteries were terrible. Orders were given to Gen. Jackson to cover the retreat in case the army should have to fall back, and directions were sent to Richmond to get all the public property ready for removal. The Federal forces, perceiving the confusion, began step by step to press forward. The posture of affairs at this time is thus related by a Confederate officer: "The enemy, noticing our confusion, now advanced, with the cry, 'Onward to Richmond!' Yes, along the whole hostile front rang the shout, 'Onward to Richmond!' Many old soldiers who had served in distant Missouri and on the plains of Arkansas wept in the bitterness of their souls like children. Of what avail had it been to us that our best blood had flowed for six long days?—of what avail all our unceasing and exhaustless endurance? Everything, everything seemed lost, and a general depression came over all our hearts. Batteries dashed past in headlong flight; ammunition, hospital and supply wagons rushed along, and swept the troops away with them from the battle field. In vain the most frantic exertion, entreaty and self-sacrifice of the staff officers! The troops had lost their foot-hold, and all was over with the Southern Confederacy.

"In this moment of desperation Gen. A. P. Hill came up with a few regiments he had managed to rally, but the enemy was continually pressing nearer and nearer; louder and louder their shouts, and the watchword, 'On to Richmond!' could be heard. Cavalry officers sprang from their saddles and rushed into the ranks of the infantry regiments, now deprived of their proper officers. Gen. Hill seized the standard of the Fourth North Carolina regiment, which he had formerly commanded, and shouted to the soldiers, 'If you will not follow me, I will perish alone.' Upon this a number of officers dashed forward to cover their beloved general with their bodies; the soldiers hastily rallied, and the cry 'Lead on, Hill; head your old North Carolina boys!' rose over the field. And now Hill charged forward with this mass he had thus worked up to the wildest enthusiasm. The enemy halted when they saw these columns, in flight a moment before, now advancing to the attack, and Hill burst upon his late pursuers like a famished lion. A fearful hand to hand conflict now ensued, for there was no time to load and fire. The ferocity with which this combat was waged was incredible. It was useless to beg the exasperated men for quarter; there was no moderation, no pity, no compassion in that bloody work of bayonet and knife. The son sank dying at his father's feet; the father forgot that he had a child—a dying child; the brother did not see that a brother was expiring a few paces from

him; the friend heard not the last groans of a friend; all natural ties were dissolved; only one feeling, one thirst, panted in every bosom—revenge. Here it was that the son of Major Peyton, but fifteen years of age, called to his father for help. A ball had shattered both his legs. 'When we have beaten the enemy then I will help you,' answered Peyton; 'I have here other sons to lead to glory. Forward!' But the column had advanced only a few paces farther when the major himself fell to the earth a corpse. Prodiges of valor were here performed on both sides. History will ask in vain for braver soldiers than those who have fought and fell. But of the demoniac fury of both parties one at a distance can form no idea. Even the wounded, despairing of succor, collecting their last energies of life, plunged their knives into the bosoms of foemen who lay near them still breathing.

"The success of General Hill enabled other generals to once more lead their disorganized troops back to the fight, and the contest was renewed along the whole line, and kept up until deep into the night; for everything depended upon our keeping the enemy at bay, counting, too, upon their exhaustion at last, until fresh troops could arrive to reinforce us. At length, about half past ten in the evening, the divisions of Magruder, Wise, and Holmes, came up and deployed to the front of our army.

"So soon as these reinforcements could be thrown to the front our regiments were drawn back, and as far as possible reorganized during the night, the needful officers appointed, and after the distribution of provisions, which had also fortunately arrived, measures were adopted for the gathering up of the wounded and the burial of the dead."

In this conflict Gen. McCall was taken prisoner by the Confederates.

During the same day an attack was made upon the corps of Gen. Porter by the divisions of Gens. Wise and Holmes near Malvern Hill, but without success.

On the night of the 30th all the divisions of the Federal army were united at Malvern Hill, a strong position where the whole train, including the siege guns, were sheltered. The army was thus in communication with its transports and supplies. Five days of incessant marching and fighting had passed, during which many had been sun struck by the heat, and others from exhaustion had quitted the ranks and fell into the procession of sick and wounded. Attacked by a force far superior to itself, it had succeeded in reaching a position where it was out of danger and from which, if reinforced, it could have advanced.

Gen. McClellan immediately put his army in a position for defence by arranging his batteries along the high grounds so as not to interfere with the defence by the infantry of the sort of glacis upon which the enemy would be obliged to advance to the attack. About four p. m. on the 1st of July, the Confederate forces

advanced to storm the position. But a destructive fire of grape mowed them down until the fragments of their divisions were compelled to seek shelter in the woods. The position being within range of the gunboats they also opened a destructive fire with their hundred pounders upon the enemy. The attack was a failure, the loss of the Confederates being immense while that of the Federal troops was insignificant. On the evening after the battle the exhausted enemy retired to Richmond to appear no more, and the army of the Potomac took up a position at Harrison's Bar, a spot chosen by the engineers and naval officers as the most favorable for defence and for receiving supplies.

These battles were fought at a time when the military strength of the Confederate States had been brought into the field and concentrated at Richmond. Thus the Confederate army greatly outnumbered the Federal force, reduced by losses during the campaign and by sickness, on the banks of the Chickahominy. No official reports have appeared of the losses on either side. They were not far from fifteen thousand men. On the 3d of July the War Department published a despatch from Gen. McClellan dated at Berkeley, Harrison's Bar, stating that he had lost but one gun, which broke down and was abandoned, and that the rear of his train was then within a mile of camp and only one wagon abandoned.

On the 4th of July Gen. McClellan issued the following address to his army:

HEADQUARTERS, ARMY OF THE POTOMAC. }  
CAMP NEAR HARRISON'S LANDING, July 4, 1862. }

SOLDIERS OF THE ARMY OF THE POTOMAC: YOUR achievements of the past ten days have illustrated the valor and endurance of the American soldier. Attacked by superior forces, and without hopes of reinforcements, you have succeeded in changing your base of operations by a flank movement, always regarded as the most hazardous of military operations. You have saved all your guns except a few lost in battle, taking in return guns and colors from the enemy.

Upon your march you have been assailed, day after day, with desperate fury, by men of the same race and nation, skillfully massed and led. Under every disadvantage of number, and necessity of position also, you have in every conflict beaten back your foes with enormous slaughter.

Your conduct ranks you among the celebrated armies of history. None will now question what each of you may always, with pride, say: "I belonged to the Army of the Potomac." You have reached this new base complete in organization and unimpaired in spirit. The enemy may at any time attack you—we are prepared to meet them. I have personally established your lines. Let them come, and we will convert their repulse into a final defeat.

Your government is strengthening you with the resources of a great people. On this, our nation's birthday, we declare to our foes, who are rebels against the best interests of mankind, that this army shall enter the capital of the so-called Confederacy; that our national Constitution shall prevail, and that the Union, which can alone insure internal peace and external security to each State, must and shall be preserved, cost what it may in time, treasure, and blood.

GEO. E. McCLELLAN,  
Major-General Commanding.

On the 5th President Davis issued the following address to the Confederate army:

RICHMOND, July 5, 1862.

*To the Army in Eastern Virginia:*

SOLDIERS; I congratulate you on the series of brilliant victories which, under the favor of Divine Providence, you have lately won, and as the President of the Confederate States, do heartily tender to you the thanks of the country, whose just cause you have so skilfully and heroically served. Ten days ago, an invading army, vastly superior to you in numbers and the material of war, closely beleaguering your capital and vauntingly proclaimed its speedy conquest; you marched to attack the enemy in his intrenchments; with well directed movements and death-defying valor, you charged upon him in his strong positions, drove him from field to field over a distance of more than thirty-five miles, and despite his reinforcements compelled him to seek safety under the cover of his gunboats, where he now lies cowering before the army so lately derided and threatened with entire subjugation. The fortitude with which you have borne toil and privation, the gallantry with which you have entered into each successive battle, must have been witnessed to be fully appreciated; but a grateful people will not fail to recognize you and to bear you in loved remembrance. Well may it be said of you that you have "done enough for glory;" but duty to a suffering country and to the cause of constitutional liberty, claims from you yet further effort. Let it be your pride to relax in nothing which can promote your future efficiency; your one great object being to drive the invader from your soil, and, carrying your standards beyond the outer boundaries of the Confederacy, to wring from an unscrupulous foe the recognition of your birthright, community, and independence.

[Signed]

JEFFERSON DAVIS.

Early in July Gen. Halleck resigned his command of the army of the West, and in obedience to an order of the President assumed, on the 23d of July, the duties of general-in-chief of the entire army of the United States. This was the position held by Gen. McClellan, previous to his departure from Washington to conduct the peninsular campaign. Its duties had been subsequently performed by the Secretary of War, under the supervision of President Lincoln, assisted by the counsel of Maj.-Gen. Hitchcock, an elderly officer of the army. Gen. Halleck, upon assuming these duties, had his attention immediately called to the army of the Potomac. He thus relates his action in relation to it:

"The first thing to which my attention was called on my arrival here (at Washington), was the condition of the army at Harrison's Landing, on the James river. I immediately visited Gen. McClellan's headquarters for consultation. I left Washington on the 24th and returned on the 27th. The main object of this consultation was to ascertain if there was a possibility of an advance upon Richmond from Harrison's Landing, and if not to favor some plan of uniting the armies of Gen. McClellan and Gen. Pope on some other line. Not being familiar with the position and numbers of the troops in Virginia and on the coast, I took the President's estimate of the largest number of reinforcements that could be sent to the army of the Potomac.

"On the day of my arrival at Harrison's Landing Gen. McClellan was of opinion that he would require at least 50,000 additional troops. I informed him that this number could

not possibly be sent; that I was not authorized to promise him over 20,000, and that I could not well see how even that number could be safely withdrawn from other places. He took the night for considering the matter, and informed me the next morning that he would make the attempt upon Richmond with the additional 20,000, but immediately on my return to Washington he telegraphed that he would require 35,000, a force which it was impossible to send him without leaving Washington and Baltimore almost defenceless. The only alternative now left was to withdraw the army of the Potomac to some position where it could unite with that of Gen. Pope, and cover Washington at the same time that it operated against the enemy. After full consultation with my officers, I determined to attempt this junction on the Rappahannock, by bringing McClellan's forces to Aquia Creek.

"Accordingly, on the 30th of July, I telegraphed to him to send away his sick as quickly as possible, preparatory to a movement of his troops. This was preliminary to the withdrawal of his entire army, which was ordered by telegraph on the 3d of August. In order that the transfer to Aquia Creek might be made as rapidly as possible, I authorized Gen. McClellan to assume control of all the vessels in the James river and Chesapeake Bay, of which there was then a vast fleet. The quartermaster-general was also requested to send to that point all the transports that could be procured. On the 5th I received a protest from Gen. McClellan, dated the 4th, against the removal of the army from Harrison's Landing. On the 1st of August I ordered Gen. Burnside to immediately embark his troops at Newport News, transfer them to Aquia Creek, and take position opposite Fredericksburg. This officer moved with great promptness, and reached Aquia Creek on the night of the 3d. His troops were immediately landed, and the transports sent back to Gen. McClellan.

"About this time I received information that the enemy were preparing a large force to drive back Gen. Pope, and attack either Washington or Baltimore. The information was so direct and trustworthy that I could not doubt its correctness. This gave me serious uneasiness for the safety of the capital and Maryland, and I repeatedly urged upon Gen. McClellan the necessity of promptly moving his army so as to form a junction with that of Gen. Pope. The evacuation of Harrison's Landing, however, was not commenced till the 14th, eleven days after it was ordered."

The following correspondence, respecting this removal of the army of the Potomac, took place between Gen. McClellan and Gen. Halleck:

BRECKLEY, Va., August 4, 19 M.

Maj.-Gen. Halleck, Commander-in-Chief:

Your telegraph of last evening is received. I must confess that it has caused me the greatest pain I ever experienced, for I am convinced that the order to withdraw this army to Aquia Creek will prove disastrous in

the extreme to our cause. I fear it will be a fatal blow. Several days are necessary to complete the preparations for so important a movement as this, and while they are in progress, I beg that careful consideration may be given to my statement. This army is now in excellent discipline and condition. We hold a *de-bouche* on both banks of the James river, so that we are free to act in any direction, and, with the assistance of the gunboats, I consider our communications as secure.

We are twenty-five miles from Richmond, and are not likely to meet the enemy in force sufficient to fight a battle until we have reached fifteen to eighteen miles, which brings us practically within ten miles of Richmond. Our longest line of land transportation would be from this point twenty-five miles, but with the aid of the gunboats we can supply the army by water, during its advance, certainly to within twelve miles of Richmond. At Aquia Creek we would be seventy-five miles from Richmond, with land transportation all the way. From here to Fortress Monroe is a march of about seventy miles, for I regard it as impracticable to withdraw this army and its material, except by land. The result of the movement would thus be to march one hundred and forty-five miles to reach a point now only twenty-five miles distant, and to deprive ourselves entirely of the powerful aids of the gunboats and water transportation. Add to this the certain demoralization of this army, which would ensue; the terrible depressing effect upon the people of the North, and the strong probability that it would influence foreign Powers to recognize our adversaries; and these appear to me sufficient reasons to make it my imperative duty to urge in the strongest terms afforded by our language, that this order may be rescinded, and that, far from recalling this army, it may be promptly reinforced to enable it to resume the offensive.

It may be said that there are no reinforcements available. I point to Gen. Burnside's force, to that of Gen. Pope, not necessary to maintain a strict defence in front of Washington and Harper's Ferry; to those portions of the Army of the West not required for a strict defence there. Here, directly in front of this army, is the heart of the rebellion. It is here that all our resources should be collected to strike the blow which will determine the fate of this nation. All points of secondary importance elsewhere should be abandoned, and every available man brought here. A decided victory here, and the military strength of the rebellion is crushed. It matters not what partial reverses we may meet with elsewhere, here is the true defence of Washington; it is here, on the bank of the James river, that the fate of the Union should be decided.

Clear in my conviction of right, strong in the consciousness that I have ever been, and still am, actuated solely by love of my country, knowing that no ambitious or selfish motives have influenced me from the commencement of this war; I do now what I never did in my life before, I entreat that this order may be rescinded. If my counsel does not prevail, I will, with a sad heart, obey your order to the utmost of my power, devoting to the movement, which I clearly foresee will be one of the utmost delicacy and difficulty, whatever skill I may possess, whatever the result may be, and may God grant that I am mistaken in my forebodings. I shall at least have the internal satisfaction that I have written and spoken frankly, and have sought to do the best in my power to arrest disaster from my country.

GEO. B. McCLELLAN, Major General.

GEN. HALLECK TO GEN. McCLELLAN.

WASHINGTON, Aug 6, 1862.

Maj.-Gen. Geo. B. McClellan, Commanding, &c.,  
Berkeley, Va.:

GENERAL—Your telegram of yesterday was received this morning, and I immediately telegraphed a brief reply, promising to write you more fully by mail. You, General, certainly could not have been more pained at receiving my order than I was at the necessity of issuing it. I was advised by high officers, in

whose judgment I had great confidence, to make the order immediately on my arrival here, but I determined not to do so until I could learn your wishes from a personal interview; and even after that interview I tried every means in my power to avoid withdrawing your army, and delayed my decision as long as I dared, to delay it. I assure you, General, it was not a hasty and inconsiderate act, but one that caused me more anxious thought than any other of my life. But after full and mature consideration of all the pros and cons, I was reluctantly forced to the conclusion that the order must be issued. There was to my mind no other alternative.

Allow me to allude to a few of the facts of the case. You and your officers, at our interview, estimated the enemy's forces in and around Richmond at 200,000 men. Since then you and others report that they have received and are receiving large reinforcements from the south. General Pope's army, now covering Washington, is only 40,000. Your effective force is only about 90,000. You are thirty miles from Richmond, and Gen. Pope eighty or ninety. With the enemy directly between you, ready to fall with his superior numbers upon one or the other, as he may elect, neither can reinforce the other in case of such an attack.

If Gen. Pope's army be diminished to reinforce you, Washington, Maryland, and Pennsylvania would be left uncovered and exposed. If your force be reduced to strengthen Pope, you would be too weak to even hold the position you occupy should the enemy turn round and attack you in full force. In other words, the old Army of the Potomac is split into two parts, with the entire force of the enemy directly between them. They cannot be united by land without exposing both to destruction, and yet they must be united. To send Pope's forces by water to the peninsula is, under present circumstances, a military impossibility. The only alternative is to send the forces on the peninsula to some point by water—say Fredericksburg—where the two armies can be united. Let me now allude to some of the objections which you have urged.

You say that to withdraw from the present position will cause the certain demoralization of the army, which is now in excellent condition and discipline. I cannot understand why a simple change of position to a new and by no means distant base will demoralize an army in excellent discipline, unless the officers themselves assist in the demoralization, which I am satisfied they will not. Your change of front from your extreme right at Hanover Court House to your present position was over thirty miles, but I have not heard that it demoralized your troops, notwithstanding the severe losses they sustained in effecting it.

A new base on the Rappahannock, at Fredericksburg, brings you within about sixty miles of Richmond, and secures a reinforcement of forty or fifty thousand fresh and disciplined troops. The change, with such advantages, will, I think, if properly represented to your army, encourage rather than demoralize your troops. Moreover, you yourself suggested that a junction might be effected at Yorktown, but that a flank march across the peninsula would be more hazardous than to retire to Fort Monroe. You will remember that Yorktown is two or three miles further from Richmond than Fredericksburg is. Besides the latter is between Richmond and Washington, and covers Washington from any attack by the enemy.

The political effect of the withdrawal may at first look unfavorable, but I think the public are beginning to understand its necessity; and that they will have much more confidence in a united army than in its separate fragments. But you will reply, Why not reinforce me here, so that I can strike Richmond from my present position? To do this, you said at our interview that you required 50,000 additional troops. I told you that it was impossible to give you so many. You finally thought you would have "some chance" of success with 20,000; but you afterward telegraphed to me that you would require 35,000, as the enemy was being largely reinforced.

If your estimate of the enemy's strength was correct, your requisition was perfectly reasonable; but it was

utterly impossible to fill it until new troops could be enlisted and organized, which would require several weeks. To keep your army in its present position until it could be so reinforced would almost destroy it in that climate. The months of August and September are almost fatal to whites who live on that part of James river, and even after you got the reinforcements asked for, you admitted that you must reduce Fort Darling and the river batteries before you could advance on Richmond. It is by no means certain that the reduction of these fortifications would not require considerable time, perhaps as much as those at Yorktown. This delay might not only be fatal to the health of your army, but in the mean time Gen. Pope's forces would be exposed to the heavy blows of the enemy, without the slightest hope of assistance from you.

In regard to the demoralizing effect of a withdrawal from the peninsula to the Rappahannock, I must remark that a large number of your highest officers—indeed a majority of those whose opinions have been reported to me—are decidedly in favor of the movement. Even several of those who originally advocated the line of the peninsula now advise its abandonment. I have not inquired, and do not desire to know, by whose advice or for what reason the Army of the Potomac was separated into two parts, with the enemy before them. I must take things as I find them. I find our forces divided, and I wish to unite them. Only one feasible plan has been presented for doing this. If you or any one else had presented a better one, I certainly should have adopted it; but all of your plans require reinforcements which it is impossible to give you. It is very easy to ask for reinforcements, but it is not so easy to give them when you have no disposable troops at your command. I have written very plainly, as I understand the case, and I hope you will give me credit for having carefully considered the matter, although I may have arrived at different conclusions from your own. Very respectfully, your obedient servant,

H. W. HALLECK, General-in-Chief.  
(Official Copy.) J. C. KELTON, Assistant Adj.-Gen.

Thus the campaign was closed. The once proud Army of the Potomac was withdrawn from the peninsula to Aquia Creek and Alexandria, and its corps were immediately ordered into the field to reinforce the army of Gen. Pope southeast of Washington, and to act under his command.

By an order of the President on the 27th of June, Maj.-Gen. Pope, who had been in command of a force in the West, entered upon the chief command of the army of Virginia.

The following is the order of the President creating the Army of Virginia, and putting Gen. Pope in command, dated June 27, 1862:

I. The forces under Maj.-Gens. Fremont, Banks, and McDowell, including the troops now under Brig.-Gen. Sturgis, at Washington, shall be consolidated and form one army, to be called the Army of Virginia.

II. The command of the Army of Virginia is specially assigned to Maj.-Gen. John Pope as Commanding General.

The troops of the Mountain Department, heretofore under command of Gen. Fremont, shall constitute the first army corps, under the command of Gen. Fremont.

The troops of the Shenandoah Department, now under Gen. Banks, shall constitute the second army corps, and be commanded by him.

The troops under the command of Gen. McDowell, except those within the fortifications and the city of Washington, shall form the third army corps, and be under his command.

The creation of the several separate and independent commands which constituted the forces west and southwest of Washington had always been looked upon with distrust. Hence

the consolidation of these forces under one commander was regarded with much satisfaction by the public, as a wise and prudent measure.

The appointment of Gen. Pope to the chief command was not favorably received by Maj.-Gen. Fremont. Consequently the following order was issued from the War Department:

WAR DEPARTMENT, WASHINGTON, June 27, 1862.

Maj.-Gen. John C. Fremont, having asked to be relieved from command of the First Army Corps of the Army of Virginia, because, as he says, the position assigned him by the appointment of Maj.-Gen. Pope as commander-in-chief of the Army of Virginia is subordinate and inferior to those heretofore held by him, and to remain in the subordinate command now assigned him would, as he says, largely reduce his rank and consideration in the service—

It is ordered by the President that Maj.-Gen. John C. Fremont be relieved from command.

Second, that Gen. Rufus King be and he is hereby assigned to the command of the First Army Corps of the Army of Virginia, in place of Gen. Fremont, relieved by order of the President.

EDWARD M. STANTON, *Secretary of War.*

On the next day Gen. Fremont issued an order declaring his resignation of the command of his forces and assigning it to Brig.-Gen. Schenck. The ground upon which the resignation of Gen. Fremont was made, was understood to be that Gen. Pope, who had been appointed to the command of the army of Virginia, was his inferior in rank, and he could not consistently command a corps under him. Gen. Schenck, on assuming command, issued the following order:

Brig.-Gen. Schenck, in assuming the new position to which the General commanding has done him the honor thus to assign him, desires to express his great satisfaction that it will only somewhat change his relation to the troops which have heretofore been under his command, but without separating him from them. He takes this occasion to say to the officers and men with whom he has been connected, that he congratulates himself on having those who have so commended themselves by their discipline, obedience, and general good conduct, still left in his division. He regrets for similar reasons to part with Capt. Rigby, his officers and men; and he confidently hopes, as to the troops whose accession to the brigade will extend his command, that the relation between himself and them, as well as with all his old companions, will continue to be mutually agreeable and advantageous.

By order of Brig.-Gen. SCHENCK.

DONN PIATT, Captain and A. A.-G.

At night of the same day he learned that Gen. Rufus King had been ordered to the command of that corps, and sent in his request to be relieved of command in that portion of the army. But on the subsequent day, still further learning that Gen. King had been detached and Gen. Sigel ordered to the same command, he withdrew his resignation.

Meantime Maj.-Gen. Pope was making his arrangements to take the field. On the 14th of July he issued the following address to his army:

*To the Officers and Soldiers of the Army of Virginia:*

By special assignment of the President I have assumed command of this army. I have spent two weeks in learning your whereabouts, your condition, and your wants, in preparing you for active operations and in placing you in a position from which you can act

promptly and to the purpose. These labors are nearly completed, and I am about to join you in the field. Let us understand each other. I have come to you from the West where we have always seen the backs of our enemies—from an army whose business it has been to seek an adversary and beat him when found; whose policy has been attack and not defence. In but one instance has the enemy been able to place our Western armies in a defensive attitude. I presume I have been called here to pursue the same system, and to lead you against the enemy. It is my purpose to do so and that speedily. I am sure you long for an opportunity to win the distinction you are capable of achieving; that opportunity I shall endeavor to give you. In the mean time I desire you to dismiss certain phrases I am sorry to find much in vogue amongst you. I hear constantly of taking strong positions and holding them—of lines of retreat and bases of supplies. Let us discard such ideas. The strongest position a soldier should desire to occupy is one from which he can most easily advance against the enemy. Let us study the probable line of retreat of our opponents, and leave our own to take care of itself. Let us look before us, and not behind. Success and glory are in the advance—disaster and shame lurk in the rear. Let us act on this understanding, and it is safe to predict that your banners shall be inscribed with many a glorious deed, and that your names will be dear to your countrymen forever.

(Signed) JOHN POPE, Maj.-Gen. Commanding.

Subsequent orders issued by Gen. Pope at this time indicate the manner in which he proposed to conduct the campaign, as follows:

HEADQUARTERS OF THE ARMY OF VIRGINIA, }  
WASHINGTON, July 18, 1862. }

*General Orders, No. 5:*

Hereafter, as far as practicable, the troops of this command will subsist upon the country in which their operations are carried on. In all cases supplies for this purpose will be taken by the officers to whose department they properly belong, under the orders of the commanding officer of the troops for whose use they are intended. Vouchers will be given to the owners, stating on their face that they will be payable at the conclusion of the war upon sufficient testimony being furnished that such owners have been loyal citizens of the United States since the date of the vouchers.

Whenever it is known that supplies can be furnished in any district of the country where the troops are to operate, the use of trains for carrying subsistence will be dispensed with as far as possible.

By command of Maj.-Gen. POPE.

GEO. D. RUGGLES, Col. A. A.-G. and Chief of Staff.

HEADQUARTERS OF THE ARMY OF VIRGINIA, July 18, 1862.  
*General Orders, No. 6:*

Hereafter in any operations of the cavalry forces in this command no supply or baggage trains of any description will be used unless so stated especially in the order for the movement. Two days' cooked rations will be carried on the persons of the men, and all villages and neighborhoods, through which they pass, will be laid under contribution in the manner specified by General Orders, No. 5, current series, from these headquarters, for the subsistence of men and horses.

Movements of cavalry must always be made with celerity, and no delay in such movements will be excused hereafter on any pretext.

Whenever the order for the movement of any portion of the army emanates from these headquarters, the time of marching and that to be consumed in the execution of the duty will be specifically designated, and no departure therefrom will be permitted to pass unnoticed without the gravest and most conclusive reasons.

Commanding officers will be held responsible for strict and prompt compliance with every provision of this order.

By command of Maj.-Gen. POPE.

GEO. D. RUGGLES, Col. A. A.-G. and Chief of Staff.

Another order was issued on the same day, declaring that the inhabitants along the lines of railroads and telegraphs and the routes of travel, would be held responsible for any injury done to track, line, or road, or for any attacks on trains or stragglers by bands of guerillas in their neighborhood. In cases of damage to roads the citizens, within five miles, would be turned out in mass to repair the damage. If a soldier or legitimate follower of the army was fired upon from any house, the same should be razed to the ground. By another order all disloyal citizens within the lines of the army, or within the reach of its respective officers, were to be arrested at once. Those taking the oath of allegiance, and giving sufficient security for its observance, were to be allowed to remain; all others were to be conducted to the South, beyond the extreme pickets, and if again found anywhere within the lines, were to be treated as spies and subjected to the extreme rigor of military law. These orders of Gen. Pope were followed by the pillaging of private property and by insults to females to a degree unknown heretofore during the war. The Confederate Government, by way of retaliation, issued an order declaring that Gen. Pope and the commissioned officers serving under him, were "not entitled to be considered as soldiers, and therefore not entitled to the benefit of cartel for the parole of future prisoners of war. Ordered, further, that in the event of the capture of Maj.-Gen. Pope, or any commissioned officer serving under him, the captive so taken shall be held in close confinement so long as the orders aforesaid shall continue in force, and unrepealed by the competent military authority of the United States, and that in the event of the murder of an unarmed citizen or inhabitant of this Confederacy by virtue or under pretence of the order hereinbefore recited, it shall be the duty of the commanding general of the forces of this Confederacy to cause immediately to be hung, out of the commissioned officers prisoners as aforesaid, a number equal to that of our own citizens thus murdered by the enemy."

The main divisions of Gen. Pope's army were now stationed at Culpepper Court House and Fredericksburg. Culpepper Court House is about seventy miles from Washington and equally distant from Richmond. The route crosses the Long Bridge at Washington, thence through Alexandria, Fairfax, Manassas, Warrenton, &c. Fredericksburg is connected with Washington by steamboat navigation on the Potomac to Aquia Creek, thence by railroad, fifteen miles, to Fredericksburg, which is sixty miles by railroad from Richmond. Gen. Pope, although not personally in the field until the 27th of July, had been engaged in concentrating his forces. His delay in taking the field was occasioned by the absence of Maj.-Gen. Halleck, who arrived at Washington on the 23d of July, and entered upon the duties of general-in-chief.

A show of force had been kept up in the Shenandoah Valley, and east of the Blue Ridge, by the Confederate Government throughout the month of July, chiefly for the purpose of preventing reinforcements to Gen. McClellan. The knowledge which it had of the position and strength of the Federal forces made it manifest that no reinforcement to the Army of the Potomac would come from any other quarter. The departure of the division of Gen. Burnside from Newport News, where it had been for some weeks ready to cooperate with Gen. McClellan in any forward movements to Aquia Creek on the 1st of August, was immediately known in Richmond. It showed not only that no reinforcements were coming to the Army of the Potomac, but also that this army would soon evacuate the peninsula. The star of their fortune now appeared to be in the ascendant. The day, so long and anxiously looked for, had come, in which they should be able to strike their great and powerful adversary at a disadvantage, and demonstrate to civilized nations their own military strength and ability to win that independence which they had proclaimed. Consultations were immediately held at Richmond, and their purposes were soon formed. It was resolved to abandon the defensive policy and to repeat the exploit which Gen. Jackson had performed by driving Gen. Banks out of the Shenandoah Valley, on a scale of national magnitude. Rumors were set afloat that Tennessee, Kentucky, and the whole of Virginia were to be recovered at once; Maryland liberated from her oppression, and not only Washington and Baltimore captured, but also Harrisburg and Philadelphia in the east, and Cincinnati in the west. It was a magnificent enterprise for a people situated like those in the Confederate States at that time. Measures were immediately adopted for the execution of these plans. Gen. McClellan was to be left to retire from the peninsula without any further attacks than were necessary to cover their real designs, and their forces were to be prepared for an immediate movement northward. The Confederate forces at this time were greater than ever before. Not less than one hundred and fifty thousand men were at Richmond and in communication with it. All this force, excepting a strong corps of observation, was to be precipitated at once upon Maryland.

The preparations to advance into Maryland which were making at Richmond, were immediately known at Washington and awakened great anxiety. An order was issued to Gen. Cox in western Virginia to send his main forces, with all possible despatch, by railroad to join Gen. Pope. To facilitate the withdrawal of the army from Harrison's Landing, as stated by Gen. Halleck, and to gain time also by a demonstration against the enemy, Gen. Pope was ordered to push his forces across the Rappahannock, and occupy Culpepper and threaten Gordonsville. At the same time President Lin-

coln issued the following order, calling out an additional three hundred thousand men to serve for nine months:

WAR DEPARTMENT, WASHINGTON, August 4, 1862.

*Ordered First*—That a draft of three hundred thousand militia be immediately called into the service of the United States, to service for nine months, unless sooner discharged. The Secretary of War will assign the quotas to the States, and establish regulations for the draft.

*Second*—That if any State shall not by the 15th of August furnish its quota of the additional three hundred thousand volunteers authorized by law, the deficiency of volunteers in that State will also be made up by a special draft from the militia. The Secretary of War will establish regulations for this purpose.

*Third*—Regulations will be prepared by the War Department, and presented to the President, with the object of securing the promotion of officers of the army and volunteers for meritorious and distinguished services, and of preventing the nomination and appointment in the military service of incompetent or unworthy officers. The regulations will also provide for ridding the service of such incompetent persons as now hold commissions.

By order of the PRESIDENT.

EDWIN M. STANTON, Secretary of War.

The Confederate army began to move immediately after the 1st of August, and the divisions of Gens. Jackson, Ewell, and Hill were hurried to the Rapidan river, which is the south fork of the Rappahannock. On Friday, the 8th of August, Gen. Pope reached Culpepper Court House, from his last encampment near Washington, the county seat of Rappahannock. At the same time the corps of Gen. Banks was in motion in the direction of Culpepper. The corps of Gen. Sigel was encamped at Sperryville, twenty miles from Culpepper, and on the road from Washington, Rappahannock county. At Culpepper Court House was Brig.-Gen. Crawford, with his brigade belonging to Gen. Banks's corps, and Gen. Ricketts's division, belonging to Gen. McDowell's corps. They had arrived two days previous from Warrenton with Gen. McDowell, who took command of all the forces then at Culpepper. Gen. Bayard with his cavalry had been guarding the fords of the Rapidan from Racon Ford to a point fourteen miles below, and south of the railroad at Burnett's Ford, where he connected with the cavalry of Gen. Buford. At noon on Friday he sent information to Culpepper Court House that the enemy had early that morning crossed the river and driven in his pickets with such force that he was obliged to retire before them. He was retiring to the north and east side of Robertson's river, about eight miles from Culpepper, there to await a supporting force. The numbers of the enemy he estimated at two regiments of infantry, two pieces of light artillery, and three small regiments of cavalry. Gen. Buford at the same time reported the enemy to be advancing in heavy force upon Madison Court House, thus leaving it in doubt whether the movement was directed toward Culpepper or Madison. Wishing to maintain the communication with Fredericksburg at all hazards, Gen. Pope resolved to concentrate at Culpepper, in order to keep his forces interposed between

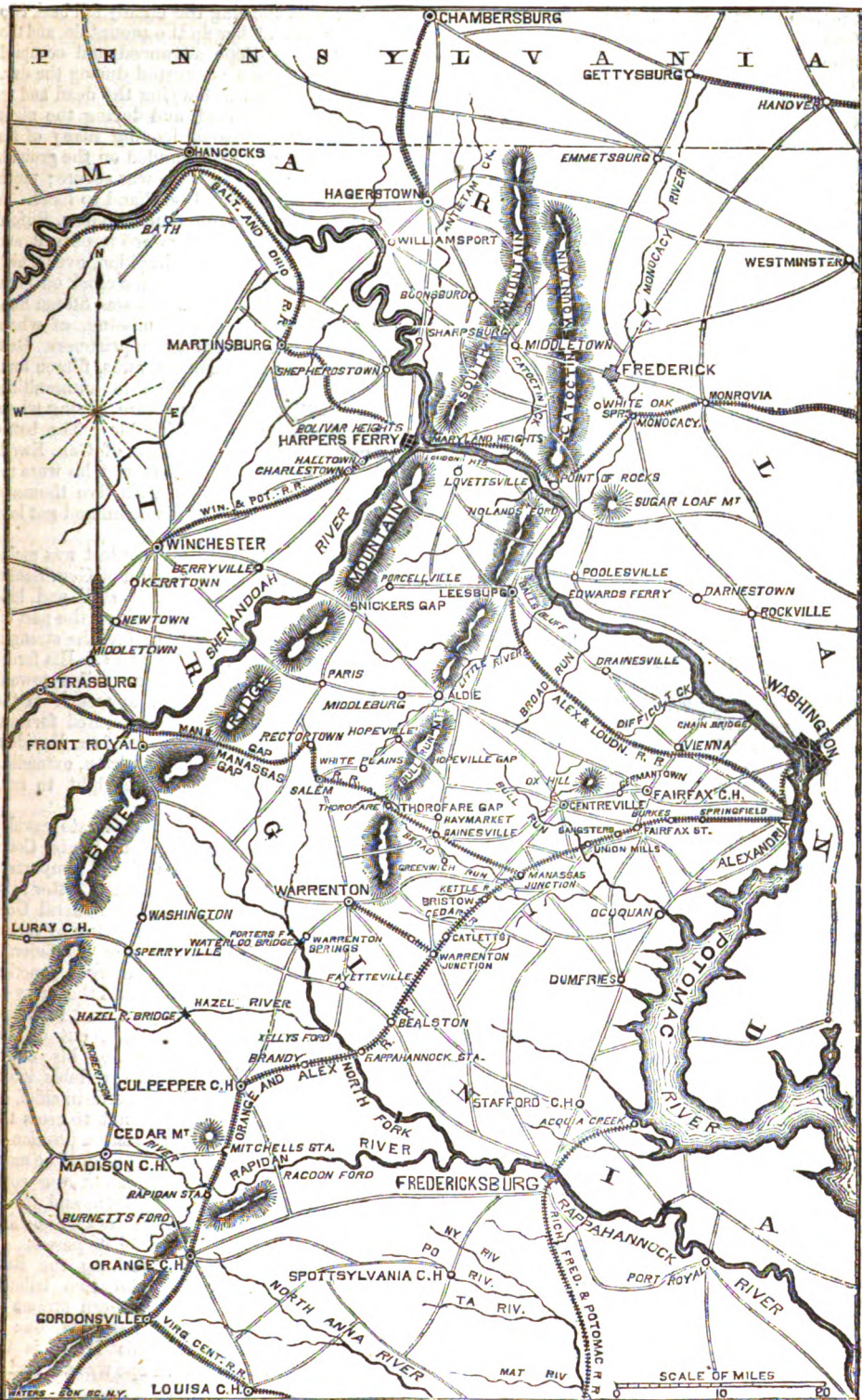



the main body of the enemy and the lower fords of the Rappahannock. He accordingly immediately ordered Brig.-Gen. Crawford to march to Gen. Bayard with his brigade, which consisted of the 28th New York, 10th Maine, 46th Pennsylvania, 25th Connecticut, with ten pieces of artillery. He proceeded rapidly to the front, and occupied a position about seven miles from Culpepper, immediately in rear of the line of Gen. Bayard's cavalry. Soon after, Gen. Pope ordered the remainder of Gen. Banks's corps to move rapidly from Hazel River bridge, nine miles from Culpepper, where it was the night before, to the scene of expected conflict. By eight o'clock that night, the head of Gen. Banks's column was descried marching around the village to its destination, which it reached before midnight. That point was immediately in the rear of Gen. Crawford. Gen. Sigel was at the same time ordered up from Sperryville by a forced march of twenty miles, his advance reaching Culpepper late in the afternoon, where it was halted.

Throughout Friday night and Saturday forenoon, skirmishing was continued between Gen. Bayard's cavalry and the advance of the enemy, until the latter had advanced within long range of Gen. Crawford's artillery. The enemy soon developed a strong force, and occupied both sides of Cedar Mountain, a sugar-loaf eminence situated two miles west of the Orange and Alexandria railroad at Mitchell's Station. The artillery of the enemy opened early in the afternoon of Saturday, but he made no advance until near five o'clock, at which time a few skirmishers were thrown forward on each side under cover of a heavy wood, in which his force was concealed. A strong force was pushed forward in the rear of the skirmishers, and Gen. Banks advanced to the attack. The engagement did not fairly open until after six o'clock P. M., but for an hour and a half was furious and unceasing. The report of Gen. Banks to Gen. Pope had expressed the opinion that no action was imminent that afternoon, and it was not until after it was fully commenced that the latter ordered Gen. McDowell to advance Gen. Ricketts's division to the support of Gen. Banks, and also Gen. Sigel to bring his men on the ground as soon as possible. At 7 P. M., when Gen. Pope arrived, the action was raging fiercely, but Gen. Banks held the position he took early in the morning. During the action he had fallen back about one mile from the spot where it first commenced, but without any disorder or confusion. The enemy were evidently pressing close, and the artillery was firing at short range. The division of Gen. Ricketts pushed forward and occupied the right of Gen. Banks, taking the place of his right wing, which was ordered to mass upon the centre. Before this change could be effected it was quite dark, and the musketry firing ceased, but the artillery kept up an intermittent firing until near midnight. The Federal troops rested on their arms during the night in line of battle. At day-

light the next morning the enemy fell back two miles, and still higher up the mountain, and the pickets of Gen. Pope advanced and occupied the ground. The army rested during the day. Monday was spent in burying the dead and in getting off the wounded, and during the night the enemy disappeared, leaving many of his dead unburied and his wounded on the ground. The slaughter on both sides was severe; much of the fighting having been hand to hand. A cavalry and artillery force under Gens. Buford and Bayard was thrown forward in pursuit, and followed the enemy to the Rapidan, over which his rear guard passed about ten o'clock on Tuesday morning. The Federal loss was fifteen hundred killed, wounded, and missing, of whom near three hundred were taken prisoners. Gen. Pope also lost two Napoleon guns, fifteen hundred muskets, and considerable ammunition. The Confederate loss was severe, among whom were Gens. Winder and Trimble. The battle commenced with the advance of Gen. Ewell, consisting of ten thousand men, who were reinforced by Gen. Jackson with five thousand more, and the balance of his command got into position early in the night.

On the Federal side the contest was maintained entirely by the command of Gen. Banks, and was conducted with great skill and bravery. The object of this attack on the part of Gen. Lee was undoubtedly to feel the strength and temper of Gen. Pope's army. His forces retired across the river, a few miles toward Gordonsville, to await the approach of the main army, while Gen. Pope pushed forward his whole force in the direction of the Rapidan, where he occupied a strong position, extending from Robertson's Rise on the right to near Raccoon Ford on the left.

On the 16th a party of Confederate cavalry were surprised and captured at Louisa Court House. Upon them were found important despatches, including an autograph letter from Gen. Lee, which informed the Federal Government that Gen. Lee was moving by forced marches the main body of the Confederate army to attack Gen. Pope before a junction could be formed between him and the Army of the Potomac. Thus their plan was to throw overwhelming forces upon him, cut off his rear, and annihilate, if possible, his entire army. In consequence of this reliable information, Gen. Halleck, the general-in-chief, on the 17th ordered Gen. Pope not to cross the Rapidan, but advised him to take a position in rear of the North Fork, where he could be more easily reinforced. This movement was commenced by Gen. Pope on the 18th, and during the 19th the main body of his forces was behind that river, and prepared to hold its passes.

Ten miles above Fredericksburg the Rappahannock river receives the two tributaries which form it. The southern stream is called the Rapidan, the northern one is called the North Fork. This latter is the stream behind which Gen. Pope was advised to

retire, and which he effected on the 18th and the subsequent day. Below the junction of the tributaries the stream is called the Rappahannock. This junction is twenty miles below the spot where the Culpepper or Orange and Alexandria railroad crosses the North Fork.

Gen. Lee commenced reconnoitring on the day that Gen. Pope retired, and at night a considerable body of his troops had crossed the Rapidan. On the 19th he crossed with a large force, comprising cavalry, infantry, and artillery.

Gen. Pope had thus far received some reinforcements from Gen. Burnside, who landed at Fredericksburg from the mouth of the James river on the 4th of August. On the 6th, at six p. m., Gen. Reno, with his division of Gen. Burnside's corps, left camp to march to Gen. Pope. On the 10th Gen. King, of McDowell's corps, hurried forward to Culpepper Court House for the same purpose, and on the 18th Gen. Stevens, with six regiments of his division, and four of Gen. Wright's, which had been detached from Port Royal, S. O., followed. Thus nearly forty regiments of infantry, fully armed and provided with trains and a large force of artillery and cavalry, were sent forward from Fredericksburg. He was also authorized to call the main portion of Gen. Cox's forces from western Virginia.

The Orange and Alexandria railroad, which runs from Alexandria, and connects with the Virginia Central railroad at Gordonville, was, at the end near Alexandria, the route by which Gen. Pope received his supplies. The stations on that part of the road were as follows: Alexandria, to Springfield, 9 miles; to Burke's, 14 miles; to Fairfax, 18 miles; to Union Mills, 23 miles; to Manassas Junction, 27 miles; to Bristol, 31 miles; to Cuddepp's, 38 miles; to Warrenton Junction, 41 miles; to Bealeton, 47 miles; to Rappahannock, 51 miles; to Brandy, 56 miles; to Culpepper, 62 miles; to Mitchell's, 69 miles. The road crosses the North Fork at the Rappahannock station, ten miles beyond Warrenton Junction. At Manassas Junction the Manassas Gap railroad comes in from the northwest. The first station west of Manassas Junction is Gainesville, distant 8 miles; the next is Thoroughfare, distant from Manassas Junction 14 miles. At the Warrenton Junction comes in from the northwest the Warrenton railroad. It connects Warrenton with Warrenton Junction. All these positions were in the rear of Gen. Pope's army on the North Fork, and were involved in the subsequent movements.

When the retreat of Gen. Pope commenced, Gen. Sigel's command was in the advance, Gen. Reno's held the left in the vicinity of Mitchell's Station, on the line of the Orange and Alexandria railroad, and Gen. McDowell's forces, supported by Gen. Banks, occupied the right centre. At half-past ten on the night of the 18th of August, Gen. Sigel commenced moving back toward Culpepper. Previous to this hour, however, the troops in the rear were in motion.

The night was dark and cold, and the march slow in consequence of the immense train of transportation wagons placed in advance of the troops. The usual camp fires were extinguished, excepting those necessary for the safe passage of the trains, and all unnecessary noise was avoided. At midnight the advance of Gen. Sigel reached Cedar Mountain, the scene of the late battle, and at a late hour on Tuesday morning, the 19th, it reached Culpepper. The forces of Gen. McDowell, including Gen. King's division, had then passed through the town. Gen. Banks's division was at an encampment on the right of the road, and Gen. Sigel brought up the rear. Far as the eye could reach, there was to be seen nought but moving masses of infantry, cavalry, and artillery; beyond that it could catch an occasional glimmer of the white-covered tops of the wagon trains slowly winding up the distant hills. All the sick and wounded, excepting eighty-five men whose injuries were of such a kind as to prevent their removal, and all the stores of the medical department, had been sent off by railroad before five o'clock that afternoon. The rear guard of the army consisted of the cavalry under Gen. Bayard. The movement of the troops during the day, although made in different directions, all tended toward one point, the Rappahannock station on the railroad, at which was the bridge crossing the North Fork. During the forenoon of the 19th, the advance crossed, and the rear, which was that day under Gen. Sigel, encamped at night some four miles from the bridge. All night, long army trains, infantry, and artillery were moving across the bridge, and by noon on the 20th the cavalry composing the rear guard made its appearance just on the west side of the bridge, and was then drawn up in line of battle to meet the enemy's cavalry, with whom Gen. Bayard had been skirmishing from Cedar Mountain. About one o'clock the Confederate cavalry made a charge, but accomplished nothing except wounding a few men. The Federal cavalry then came across the bridge, and the retreat behind the North Fork of the Rappahannock was complete.

During the afternoon and night, the Confederate artillery came up. On the next day, the 21st, being Thursday, an attempt was made by them to cross a few miles above the bridge. The New York battery of Crowell and the Third Maryland regiment, stationed at the ford, would have been driven off except for the additional batteries sent to their support. At the same time an attack was made at Kelly's Ford; this was also repulsed. An attack of the enemy was expected during the night, and the Federal force slept on their arms. Early the next morning a Confederate battery opened at the spot where the first attempt to cross was made, which kept up a fire for some time. A little farther up the stream a bridge was discovered which the enemy had erected during the night. A Federal battery opened, which slackened fire soon after and appeared to be silenced by the

batteries of the enemy. It was apparently withdrawn, when the enemy began to cross. The batteries of Gen. Sigel's command again opened upon their approach, and they were here also driven back. It was on this occasion that Gen. Henry Bohlen lost his life. Attempts to cross were also made at other fords. On Friday afternoon and night of the 22d, rain fell so heavily as to swell the river and make it unfordable between the mountains and a few miles back of Warrenton Springs, which checked the efforts of the enemy. The firing of artillery at nearly all the fords was kept up on the 23d and 24th with more or less spirit, but with no special results. On the 23d the bridge at the Rappahannock station was burned by Gen. Ricketts. While this was going on during the 24th, Gen. Lee made a flank movement, advanced higher up, and attempted to throw a portion of his force over at Waterloo bridge, about twelve miles above the Rappahannock bridge, which was burned. This attempt was defeated. The strategy of the movements of Gen. Pope consisted in the hope that by his falling back across and holding the fords of the North Fork, sufficient time would be gained for the Army of the Potomac to come to his aid.

On Friday evening, the 22d, while the Federal force was thus in possession of the fords of the Rappahannock, a body of Confederate cavalry under Gen. Stuart, consisting of detachments of the 1st, 4th, and 9th Virginia cavalry, made a dash upon Catlett's Station on the Orange and Alexandria railroad, thirty-five miles from Washington, and thirteen miles in the rear of the Rappahannock station. They met with only slight resistance. There were a great number of trains in a circle round the station at the time, which first occupied their attention; but a terrible storm of rain setting in a few moments after their arrival, the wagons could not be destroyed by fire, and only few were injured. They remained some hours, and left at four o'clock in the morning, their pickets having been driven in. They took away over two hundred horses of Gen. Pope's train, and twenty from Gen. McDowell's. They took all Gen. Pope's baggage and everything belonging to his staff officers. All the sick were taken from the hospitals, and most of them put on the captured horses to ride. A few were killed on both sides, and the number of prisoners taken was about two hundred. This force had crossed the North Fork at Porter's Ford, two miles above White Sulphur Springs. The Federal force at Catlett's consisted of a small guard from the Pennsylvania regiment under Col. Kane, and the Purnell Legion of Maryland. In the neighborhood were other trains likewise having small guards, upon some of which an attack was made.

After a body of the Confederate force had crossed at Waterloo bridge on the 24th, as above stated, an attack was made upon them by order of Gen. Pope, with the hope of cutting them off. This was unsuccessful, but the enemy was compelled to retire, move farther up the river,

and enter the valley which lies between the Blue Ridge and the Bull Run mountains. The object of this movement was to get in the rear of Gen. Pope and cut off his supplies from Washington.

It put the Confederate army in such a position that it could move either upon Washington or upon Leesburg, for the purpose of crossing into Maryland. Nevertheless, Gen. Pope was successful in preventing the enemy from crossing at any of the fords of the North Fork, and compelling him to move still higher up on the west side of the Bull Run mountains. Thus, during eight days, Gen. Lee had advanced no nearer to Washington. It now remained for Gen. Pope to guard the passes of these mountains in order to prevent the approach of the enemy any nearer to Washington, or to meet him after crossing the mountains and defeat him. On the other hand it was the object of Gen. Lee to pass the mountains and take Gen. Pope in the rear if possible. At all events it was necessary for him to get rid of the army of Gen. Pope if he intended to cross over the Potomac into Maryland.

When it appeared doubtful if the North Fork river could be held long enough to effect a junction of the forces of Gen. McClellan with those of Gen. Pope, a part of the former were ordered to land at Alexandria and move out by railroad as rapidly as possible. After this movement of Gen. Lee, the remainder of Gen. McClellan's forces were ordered to land at Alexandria, and Gen. Burnside was ordered to evacuate Fredericksburg and Aquia Creek.

As soon as Gen. Pope discovered that a large force of the enemy was turning his right toward Manassas, and that the divisions which he expected to be there from Alexandria had not arrived, he broke up his camps at Warrenton and Warrenton Junction and marched rapidly back in three columns. At this time the corps of Gen. Heintzelman from Gen. McClellan's army had reached Warrenton Junction, although without artillery, wagons, or horses for the field and general officers. One division of the corps of Gen. Porter from Gen. McClellan's army coming by the way of Fredericksburg, arrived at Bealston's Station, eleven miles south of Warrenton Junction in advance of Gen. Heintzelman, about four thousand five hundred strong. The other division was at Kelly's Ford. This corps had marched night and day to join the army under Gen. Pope, and was broken down with excessive labor. Both these divisions were immediately concentrated at Warrenton Junction. When Gen. Pope determined to fall back he had no other course to pursue, except to detach a sufficient force to defeat the Confederate troops attempting to turn his flank, and still preserve his front before the main body of the Confederate army. The reason assigned by Gen. Pope for not pursuing the latter course was the lack of a sufficient force to maintain his front after a suitable body had been detached to defeat Gen. Jackson on his flank. He estimates the number of his troops at forty

thousand, before the arrival of Gen. Heintzelman with ten thousand. The Confederate army before him was not less than eighty thousand in number. On evacuating Warrenton and Warrenton Junction, Gen. McDowell was ordered to march rapidly with his own corps and that of Gen. Sigel, and the division of Gen. Reynolds, by the turnpike upon Gainesville, the first station west of Manassas Junction, on the Gap railroad, for the purpose of intercepting any reinforcements coming through Thoroughfare Gap to Gen. Jackson, who he learned was on the railroad. At the same time Gen. Reno, from Gen. Burnside's corps, and Gen. Kearny, from Gen. Heintzelman's corps, were ordered to march upon Greenwich, so as to support Gen. McDowell if necessary. Greenwich is a little south of Gainesville, and a little southwest of Manassas Junction. The division of Gen. Hooker, under Gen. Pope, moved back upon Manassas, on the line of the railroad. Gen. Porter was ordered to remain with his corps at Warrenton Junction until relieved by Gen. Banks marching from Fayetteville, and then to push forward in the direction of Gainesville, where the main collision with the enemy was expected.

On Tuesday night, the 26th, the pickets at Manassas Junction were driven in, and two companies of Pennsylvania infantry, one company of Pennsylvania cavalry, and a battery of artillery stationed there were surprised and attacked by a large force under Gen. Ewell. The Union force, after a brief skirmish, retreated across Bull Run. There, at Union Mills, were the 11th and 12th Ohio regiments under Col. Scammon, being a portion of Gen. Cox's division brought on from western Virginia. They immediately advanced to meet the Confederate force, and early on Wednesday morning, the 27th, a conflict took place between Manassas Junction and Bull Run. This continued for a couple of hours, when Col. Scammon was forced to retire across Bull Run bridge, which he attempted to hold. About noon, after considerable loss, he was obliged to retire along the railroad in the direction of Alexandria, halting at a point midway between Centreville and Fairfax Court House. About two o'clock on the same morning, the New Jersey brigade under Brig.-Gen. Taylor, being a portion of Gen. Franklin's division of Gen. McClellan's army, left their encampment near Alexandria, and proceeding out the Fairfax road some distance, made a detour to the left, and during the forenoon arrived on the old battle ground near Manassas. The enemy, being aware of their approach, were drawn up to meet them. As they emerged from the woods the enemy opened upon them with a severe fire of artillery. Gen. Franklin, having no artillery, was compelled either to make a charge or retire. He resolved to charge upon the enemy's battery, but as these were supported by infantry, it proved ineffectual, and he then fell back in order to Sangster's Station, toward Fairfax, holding the

enemy in check. At this station two Ohio regiments, sent to reinforce him, came up, who were at first mistaken for a body of the enemy. The troops of Gen. Taylor were now thrown into confusion, but finding out the mistake, rallied and joined in an attack upon the enemy, who now retired toward Manassas. Gen. Taylor then fell back to Fairfax Court House, having left one regiment at Sangster's Station as a guard. The losses during these actions were about three hundred.

On the same night of the 26th, when Manassas Junction was taken, a body of Confederate cavalry, being a detachment of the force of the enemy at Manassas, made an attack upon a railroad train at Bristow's Station, four miles from Manassas Junction. This train was the one which had conveyed, a few hours previous, the division of Gen. Hooker to Warrenton Junction, and was now returning empty. The cars were destroyed and the track torn up for a considerable distance. This force was increased by the arrival of more troops from Gen. Ewell's division, who had taken Manassas Junction, where was an immense depot of Federal stores valued at nearly one million of dollars. This was the body of the enemy which Gen. Pope had designed to intercept by ordering Gen. McDowell to fall back on Gainesville. Unfortunately, his order was too late, for the first reinforcements to Gen. Jackson, then in the rear of Gen. Pope, had passed through Thoroughfare Gap and Gainesville, and were in possession of Manassas at the time when the order was given to Gen. McDowell. The stores captured at Manassas served to sustain the Confederate army in extending its march into Maryland. Vast quantities, however, were burned, because, as Gen. Lee reported, "they had captured more than they could use or carry away." On the 28d, the next day after the attack upon Catlett's Station, Gen. Halleck had sent a despatch to Gen. Pope in these words: "By no means expose your railroad communication with Alexandria. It is of the utmost importance in sending your supplies and reinforcements." Gen. Pope, in his report, says: "The movement of Gen. Jackson toward White Plains and in the direction of Thoroughfare Gap, while the main body of the enemy confronted me at Sulphur Springs and Waterloo bridge, was well known to me, but I relied confidently upon the forces which I had been assured would be sent from Alexandria, and one strong division of which I had ordered to take post on the works at Manassas Junction. I was entirely under the belief that these would be there, and it was not until I found my communication intercepted that I was undeceived. I knew that this movement was no raid, and that it was made by not less than twenty-five thousand men."

The army of Gen. Pope was now on the 27th on the retreat in three columns. The one moving back along the railroad toward Manassas Junction, under Gen. Hooker, was the first to encounter the Confederate forces in the

rear. It was the advance of the same force, a portion of which had repulsed Col. Scammon and Gen. Taylor in separate actions during the forenoon. That portion of the force had ceased to follow them beyond Sangster's Station, as they would thereby have been drawn away from the main body, and also from the support of Gen. Lee's army marching upon White Plains and Thoroughfare Gap, and because Gen. Pope was falling back upon them. Upon the approach of Gen. Hooker's force to Bristow's Station the Confederate forces fell back about one and a half miles across Kettle Run, and formed upon its left bank. Their main body was at Manassas, a little farther in the rear, to which their line of battle extended. A severe action ensued, which terminated at dark. Gen. Ewell's force was driven from the field, with the loss of his camp equipage and about three hundred killed and wounded. Gen. Hooker's division had brought with them only forty rounds of ammunition, and at night there were only five rounds to the man left. Upon learning this fact, Gen. Pope immediately sent back orders to Gen. Porter to march with his corps at one o'clock that night, so as to be with Gen. Hooker at daylight in the morning, the 28th, with Morell's division, and also directed him to communicate with Gen. Banks the order to move forward to Warrenton Junction. All trains were ordered this side of Cedar Run, and to be protected by a regiment of infantry and a section of artillery. Owing to insurmountable obstacles and the limited time given him to make the march, Gen. Porter did not arrive as early as expected.

The position of Gen. Jackson after the defeat of Ewell on the night of the 27th was dangerous. Without reinforcements he must retreat before the powerful foe in front. Only two routes were open for him. The one by which he had come, which was through Gainesville and Thoroughfare Gap; and the other toward Centreville. If he attempted the first one, he would meet the forces of Gens. McDowell and Sigel, and the Pennsylvania reserve under Gen. Reynolds, who were already at Gainesville, whither they had been ordered two days previous by Gen. Pope. His only course of safety was to fall back toward Centreville, which he did that night, and took position on the farther line of Bull Run. At noon on the 28th Manassas was occupied by the troops of Gen. Pope, and on the same day Gen. Heintzelman's corps, consisting of the divisions of Gens. Hooker and Kearny, pushed on to Centreville, and entered the place soon after the rear of Gen. Jackson had retired. At this time Gen. Reno, who had cooperated with Gen. McDowell, had reached Manassas Junction, and Gen. Porter was at Broad Run, where he had been ordered to halt. It was now of the utmost importance to Gen. Lee that Gen. Jackson should be reinforced, or he might be cut off. Foreseeing the danger, Gen. Lee had ordered Gen. Longstreet to proceed on the 24th from

Warrenton by way of Thoroughfare Gap, a pass in the Bull Run mountains, fifteen miles west of Centreville, and unite with Gen. Jackson. The advance of Gen. Longstreet appears to have reached Thoroughfare Gap on the evening of the 28th, and encountered Gen. Rickett's division, which retired that night to Bristow's Station. The enemy was thus free to join Gen. Jackson both by Thoroughfare and Hopeville Gaps. The advance of Gen. Jackson retiring to join Gen. Longstreet encountered, near Gainesville on the Warrenton turnpike, Gen. Gibbon's brigade of King's division—or all of King's division—which was a part of Gen. McDowell's force. The division behaved handsomely, and suffered severe loss. The contest closed with the darkness, and the division retired to Manassas Junction before day of the 29th. The road was open for the union of Gen. Longstreet with Gen. Jackson, and the junction was effected on the morning of the 29th, at 10 A. M., in person and with large force.

Hopeville is about three miles northeast of White Plains, on the road from White Plains to Aldie. The road across the mountains is some three miles north of Thoroughfare Gap. Gen. Halleck in his report says: "McDowell had succeeded in checking Lee at Thoroughfare Gap; but the latter took the road from Hopeville to Haymarket, and hastened to the relief of Jackson, who was already in rapid retreat."

The next morning found Gen. King's division fallen back from Warrenton turnpike toward Manassas Junction. It had been driven back by the forces of Gen. Jackson. The passage of the Gap was no longer disputed, and reinforcements to Gen. Jackson were passing through during the whole day. Gen. Lee, in his despatch to Richmond, says that Gen. Longstreet reached Gen. Jackson on the 29th. The posture of affairs was now changed. The overwhelming forces of Gen. Lee were at hand, and it became a question with Gen. Pope what the consequences to him might be. He seems to have apprehended the facts. He cautioned Gen. Porter, in his order, not to go farther in his march to effect a junction with Gen. Heintzelman than might be necessary, adding, "as he might be obliged to retire behind Bull Run that night for subsistence, if nothing else." It is worthy of notice that the movements of Gen. Jackson for the last two days had been in the direction of Thoroughfare Gap, in order to be nearer the approaching reinforcements, which he was confident would surely come. Soon after daylight on the next morning, the 29th, the contest began on the part of Gens. Sigel and Reynolds's divisions of Gen. McDowell's corps and the Confederate forces. The divisions were on the west toward Gainesville. The plan of Gen. Pope was for Gen. Heintzelman, with Gens. Hooker, Kearny, and Reno, to proceed from Centreville toward Gainesville and attack the enemy on that side, and Gen. Porter, with Gen. King's division, to make another attack from the south, and Gens. McDowell and Sigel

from the west, thus attacking them on three sides. The contest, as has been stated, commenced early in the morning on the part of Gens. Sigel and Reynolds, and was continued rather feebly until the afternoon, when Gen. Heintzelman's corps joined Gen. Sigel, and soon after Gen. Longstreet had joined Gen. Jackson. Here Gen. Grover's brigade of Gen. Hooker's division made a brilliant bayonet charge through two lines of the enemy and into a third one, losing thirty per cent. of its force in twenty minutes. Gen. McDowell also brought his whole corps into the field in the afternoon, and, as Gen. Pope says, "taking a conspicuous part in that day's operations." Gen. Porter, reduced by the withdrawal of Gen. King's division, was on the direct road to Gainesville, along the railroad from Manassas Junction, holding in check a large force of the enemy's right wing, strongly posted to guard the flank of that portion confronting Gen. Pope's right. About 7 P. M. Gen. Heintzelman's right division under Gen. Kearny turned the enemy's left toward Sudley Springs and went into action, driving them back fully a mile. Thus the day ended successfully for the Federal arms. The entire force of Gen. Pope, except Gen. Banks's corps, was thus engaged with the two wings of Gen. Lee's army. The loss on this day by Gen. Pope was reported at eight thousand, which was an overstatement. Both parties slept upon their arms that night on the same spot, near the old battle ground of Bull Run. The contest was renewed the next day, the 30th. The object now with Gen. Pope was, if possible, to maintain his position. The design of the enemy appeared to be to accumulate such a force on his right as to crush the Federal left and occupy the road to Centreville in its rear. Gen. Lee, of the Confederate army, thus reports the action of this day: "The enemy, being reinforced, renewed the attack on the afternoon of the 30th, when a general advance of both wings of the army was ordered, and after a fierce combat, which raged until after nine o'clock, he was completely defeated and driven beyond Bull Run. The darkness of the night, his destruction of the stone bridge after crossing, and the uncertainty of the fords, stopped the pursuit." The only additional force brought into this part of the field on this day by Gen. Pope was the corps of Gen. Porter, which was moved from the extreme left to the centre, travelling a distance of six miles. Gen. Pope, in his report, thus describes the conflict of the 30th: "The enemy's heavy reinforcements having reached him on Friday afternoon and night, he began to mass on his right for the purpose of crushing our left, and occupying the road to Centreville in our rear. His heaviest assault was made about five o'clock in the afternoon, when, after overwhelming Fitz John Porter, and driving his forces back on the centre and left, mass after mass of his forces was pushed against our left. A terrible contest, with great slaughter, was carried on for several hours, our men behaving with firmness and

gallantry under the immediate command of Gen. McDowell. When night closed our left had been forced back about half a mile, but still remained firm and unshaken, while our right held its ground. Gen. Franklin, with his corps, arrived after dark at Centreville, six miles in our rear, whilst Sumner was four miles behind Franklin. I could have brought up these corps in the morning in time to have renewed the action, but starvation stared both men and horses in the face, and, broken and exhausted as they were, they were in no condition to bear hunger also. I accordingly retired to Centreville that night in perfect order."

It appears that the contest with artillery commenced early in the day, and but little damage was done on either side. Early in the afternoon an attempt was made to break the line of Gen. Porter stationed on Gen. Pope's centre. This was unsuccessful, but caused a severe loss to Gen. Porter. In the latter part of the afternoon the enemy's forces were concentrated upon the corps of Gen. McDowell on the left of the centre. The batteries there, Lapine's 5th Maine, Thompson's New York, and Howell's, not being sufficiently supported by infantry, were soon captured, and McDowell's troops were driven irresistibly back. The right and centre still maintained their positions, but the disaster on the left, and the apprehended design of the enemy to occupy the road to Centreville in their rear, made it necessary for them to fall back. In doing so the bridge across Bull Run was destroyed. The field of battle with its dead and wounded was left in the hands of the enemy. The right wing of the army was this day commanded by Gen. Heintzelman, and did not give one inch of ground to the enemy until ordered so to do after the repulse received by the left wing. The losses on both sides were severe, but have never been officially made public. The report of Gen. Pope was made before the reports of his subordinate officers were received. These, in consequence of his absence in the West, had not been made near the close of the year. The entire loss of Gen. Pope was estimated at between 15,000 and 20,000.

At Richmond the following despatch was received from Gen. Lee:

HEADQUARTERS ARMY NORTHERN VIRGINIA, GROVE-  
TOWN, Aug. 30, P. M., via Rapidan. }

To President Davis:

This army achieved to-day, on the plains of Manassas, a signal victory over the combined forces of Gens. McClellan and Pope. On the 28th and 29th each wing, under Gens. Longstreet and Jackson, repulsed with valor attacks made on them separately. We mourn the loss of our gallant dead in every conflict, yet our gratitude to Almighty God for His mercies rises higher each day. To Him and to the valor of our troops a nation's gratitude is due. R. E. LEE.

This was followed on the 2d of September by the following Message of President Davis to the Confederate Congress:

To the Senate and House of Representatives of the Confederate States:  
I have the gratification of presenting to Congress

two despatches from Gen. Robert E. Lee, commanding the army of Northern Virginia, communicating the result of the operations north of the Rappahannock.

From these despatches it will be seen that God has again extended His shield over our patriotic army, and has blessed the cause of the Confederacy with a second signal victory on the field already memorable by the gallant achievement of our troops.

Too much praise cannot be bestowed upon the skill and daring of the commanding general who conceived, and the valor and bravery of the troops who executed, the brilliant movement whose result is now communicated. After having driven from their intrenchments an enemy superior in numbers, and relieved from siege the city of Richmond, as heretofore communicated, our toilworn troops advanced to meet another invading army, reinforced not only by the defeated army of Gen. McClellan, but by the fresh corps of Gens. Burnside and Heintzelman.

After forced marches, with inadequate transportation, and across streams swollen to unusual height, by repeated combats, they turned the position of the enemy, and, forming a junction of their columns in the face of greatly superior forces, they fought the decisive battle of the 30th, the crowning triumph of their toil and valor.

JEFFERSON DAVIS.

At Washington, on Saturday, the 30th, the War Department invited the citizens to go out to the battle field and assist in taking care of the wounded soldiers. A large number responded to the invitation. From three to seven o'clock P. M. the streets swarmed with people and conveyances loaded with blankets and baskets and rolls of lint. Every public carriage and vehicle was impressed into the service. A thousand persons at least went out. More would have gone on Saturday morning, but the invitation was recalled, and passes refused. The entire movement turned out as ill advised. Very few persons were allowed to go far enough to find the wounded they sought, and some were made prisoners by the Confederates. The movement thus begun at Washington instantly extended through all the principal cities of the Northern States. In Boston, Massachusetts, which will serve as an illustration of the others, the greatest excitement prevailed on Sunday, the 31st. A despatch had been received on the previous evening from Washington, by Gov. Andrew, asking that the surgeon-general of the State should send on twenty surgeons with hospital supplies as soon as possible. This demand was made public at an early hour in the morning, with the notice that contributions would be received at Tremont Temple. Those notices were also read from pulpits, which is the usual manner of advertising on Sunday in New England, and many congregations were immediately dismissed to procure contributions. At an early hour these contributions began to be received at the Temple, and continued to pour in during the whole day—old sheets for bandages, shirts, dressing gowns, pillows, liquors, jellies and sweetmeats of all kinds—in a word, every variety of article which could suggest itself to a kind heart as necessary to the comfort of the wounded soldier. Bundles and packages of every conceivable size and shape were momentarily arriving. Ladies brought bundles, who

were never seen to carry bundles before, and stout gentlemen in gold spectacles were seen driving heavy laden carts through the streets, or lending a hand at the boxes. All these articles were received at the side doors of the Temple and taken within, where corps of packers inclosed them in boxes, which were then taken out of the main entrance to the express wagons, which crowded the streets. Thus twenty-one hundred cases were packed, and all sent forward by the evening train, except about one hundred and fifty. At the same time subscriptions were taken at stands on the sidewalks, and over five thousand dollars collected.

Meantime the following correspondence took place between Gens. Pope and Lee:

CENTREVILLE, August 31, 1862.

SIR: Many of the wounded of this army have been left on the field, for whom I desire to send ambulances. Will you please to inform me whether you consent to a truce until they are cared for?

I am, sir, your obedient servant, JOHN POPE.

Maj.-Gen. U. S. Army, Commanding.  
To Commanding Officer Confed. forces, near Groveton.

HEADQUARTERS ARMY OF NORTHERN VIRGINIA, }  
August 31, 1862. }

Maj.-Gen. Pope, U. S. A., Commanding, &c.

SIR: Consideration for your wounded induces me to consent to your sending ambulances to convey them within your lines. I cannot consent to a truce nor a suspension of the military operations of this army. If you desire to send for your wounded, should your ambulances report to Dr. Guilet, Medical Director of this army, he will give directions for their transportation. The wounded will be paroled, and it is understood that no delay will take place in their removal.

Very respectfully, your obedient servant,

R. E. LEE, General.

On Sunday, the 31st, the Confederate army was put in motion toward the Little River turnpike for the purpose of turning the right of Gen. Pope. During Sunday night and Monday morning, Gen. Pope, anticipating this design of the enemy, changed his front by causing his right wing to fall back to the heights of Germantown. Thus when the enemy reached Ox Hill on Monday, he discovered Gen. Pope's army in his front on these heights. The ultimate design of the enemy was to cut the rear of Gen. Pope in the direction of Fairfax Court House. The Little River turnpike runs from Middleburg to Alexandria, and intersects the Centreville turnpike about a mile east of Fairfax Court House. Germantown is a small village between Fairfax Court House and Centreville, and about one fourth of the whole distance beyond the former.

Meanwhile, during the conflict on Friday and Saturday, Gen. Banks, with his command, was covering the extreme left of Gen. Pope's line, to keep off reinforcements for the enemy, and to be used as a reserve. He crossed to Bristow's Station, on the railroad four miles beyond Manassas Junction, and on Sunday was approached by a large Confederate force, before which he fell back and joined Gen. Pope. The bridge at Bristow's Station having been destroyed by the enemy at the time of their attack upon it, and that over Bull Run not having

been repaired, he destroyed the property of the United States before retiring. This consisted of some 200 railroad cars, 5 locomotives, and a large quantity of fixed ammunition, ordnance stores, &c. The enemy, however, obtained great spoil. On the same day, Sunday, Sept. 1, Fredericksburg was evacuated by Gen. Burnside. Falmouth Station was burned, and a quantity of commissary stores. The bridge erected in place of the old railroad bridge, the wire bridge, and the boat bridge were destroyed. The evacuation of Aquia Creek followed.

Gen. Pope states that by the reports of the commanders of corps of his army it consisted, on the 1st of September, of less than 60,000 men. The position taken by his orders on this day was as follows: The division of Gen. Couch and one brigade of Gen. Sumner's corps were at Fairfax Court House. Gen. Hooker was posted at or in front of Germantown, and had command of his own troops and those at Fairfax. Gen. McDowell's corps was stationed on the Warrenton turnpike about two miles west of Fairfax. Gen. Reno was pushed north of the turnpike at a point about two and a half miles east of Centreville, and supported by Gen. Kearny's division of Gen. Heintzelman's corps.

Late in the afternoon, the Confederates, composed of infantry and cavalry, approached Germantown by the Little River turnpike, and were met by Gen. Hooker at that place and by Gen. Reno farther west. The conflict raged for an hour, when they concentrated their force on the left of Gen. Reno's line, which was commanded by Gen. Stevens. Their intention was to turn his left flank. Gen. Stevens was soon killed by a bullet through his head, and his troops were driven back. The Confederate force now began to advance on the main body of Gen. Reno, which was short of ammunition, when the division of Gen. Kearny came up and took the position occupied by the troops of Gen. Stevens. Night had now set in, rendered thickly dark by a thunder storm. The rain fell in torrents, and the position of the contending armies was revealed only by the flashes of lightning. At this time, Gen. Kearny, anxious to know the nature of the ground upon which he expected so soon to fight, rode out to examine it. Inadvertently he passed the line of his own pickets and approached those of the Confederate force, when he was shot by one of them. He was soon missed from his camp, and not being found, Gen. Birney took command of the division. During the next day, his body was brought in under a Confederate flag of truce. Thus two most valuable officers and brave soldiers were slain in this conflict. After Gen. Birney had taken command, he ordered a bayonet charge to be made by Col. Egan, commanding the 1st and 40th, and Col. Ward, of the 38th New York regiments, before which the Confederate force retired.

By morning, on the 2d of September, the whole of Gen. Pope's army was massed behind

Difficult Creek, between Germantown, Flint Hill, and Fairfax. On that day orders were issued by the general-in-chief for the Army of Virginia to fall back within the defences of Washington. The object of the general-in-chief in giving this order was "to reorganize the different corps, to get the stragglers back into the ranks, and to supply deficiencies of ammunition, clothing, &c." This movement was executed on the 2d and 3d of September. During these days might be seen on the roads leading to Alexandria and the fortifications around Washington, the worn and bleeding fragments of the once proud armies of the North, as they straggled in from their fifteen bloody days of fighting and retreating. There were the remnants of the decimated regiments of Maine, New York, New Jersey, Pennsylvania, Ohio, and Michigan—stragglers belonging to every army corps, wounded, weak, and dispirited, retiring before a victorious enemy to obtain safety in the fortifications. Many of them had fought their way up the peninsula, contesting almost every inch from Williamsburg against bullets and bayonets until they stood in sight of the spires of Richmond at a distance of four miles, and then were required to abandon their position and withdraw.

The Confederate force which was repulsed near Centreville, on Monday night, September 2, moved toward Vienna, about twelve miles west from Washington, for the purpose of making a demonstration near the Chain Bridge, and the fords of the Potomac above Washington. The chief object in this movement was to divert the attention of the Federal officers from what Gen. Lee was doing elsewhere. The withdrawal of the army of Gen. Pope left the field clear for the Confederate army to follow it, and assault the strong fortifications of Washington, or to pass over the Potomac into Maryland. The assault upon the fortifications of Washington was not to be thought of. But the invasion of Maryland might be followed by such a welcome from the mass of the citizens, and such coöperation, as to enable Gen. Lee not only to hold a portion of the State, but to attack Washington in the rear, and perhaps invade Pennsylvania. In any event it would be a demonstration to the Federal Government, and to nations in Europe, of the vigorous energy and strength of the Confederate Government. Accordingly, on the 31st of August, while Gen. Pope was resting his exhausted forces at Centreville, Gen. Lee drew off the main body of the Confederate army and moved to Leesburg. Thence he moved to the Potomac, near Point of Rocks, and crossed at Noland's Ford, five miles below, and at a ford three miles above on the 5th. His force consisted of the divisions of Gens. Longstreet, Jackson, Ewell, A. P. Hill, and D. H. Hill. It proceeded along the eastern slope of the Catoctin Mountains, in the direction of Frederick, Maryland. On the night of the 5th the advance reached White Oak Springs, about three miles from that city, which is fifty



miles from Centreville. On the same night information was received at Frederick of the approach of the Confederate force, and it produced much excitement. A large number of the inhabitants fled toward Pennsylvania and Baltimore. Frederick, the capital of the State of Maryland, is forty-four miles northwest of Washington, and sixty miles west of Baltimore. It is the second city of the State in wealth and commercial importance, and the third in population, containing 8,143 inhabitants. The military force in the city consisted of only one company, which could make no opposition. The Federal provost marshal removed all the military stores possible, and, leaving enough for the hospitals, in which there were about six hundred patients, burned the remainder. About ten o'clock the next morning, the 6th, the Confederate troops quietly entered the city. These soldiers were in a destitute condition, in respect to clothes and shoes, yet the most scrupulous regard was had to private property. They had no tents, nor were burdened with any baggage. Their only trains were ammunition trains. If enduring great hardships without a murmur, and most bravely and heroically fighting, are evidences of good soldiers, seldom has the world witnessed better than those who composed the army of Gen. Lee. A Confederate provost marshal was appointed (Bradley Johnson), and a proclamation issued to the citizens, stating that the army came as friends, and not as enemies, to relieve the people of Maryland from the tyranny by which they were oppressed; that they did not purpose to interfere with any non-combatants, or to disturb private property, or to inquire into the opinions of citizens; and that whatever stores they required would be paid for, either in Confederate notes or United States Treasury notes, as the seller might prefer. At night the soldiers were all ordered to their camps outside of the city. Meantime foraging parties were sent out in various directions, which returned at evening with droves of sheep, cattle, hogs, and horses. These droves were all taken toward the Potomac. Pickets were thrown out from Frederick both east and west for considerable distances. On Sunday they were reported to have advanced within seven miles of Westminster, causing a great excitement in the town, but disappeared during the night. No Confederate force, however, came farther east at that time than Uniontown, twenty miles from Westminster. The main body encamped for some days on a line between Frederick and the Potomac river. Recruiting offices were opened in the city, and citizens invited to enlist. Very few volunteers, however, were obtained.

On the 8th, Gen. Lee issued the following address to the people of Maryland:

HEADQUARTERS, ARMY OF NORTHERN VIRGINIA, }  
NEAR FREDERICKTOWN, Sept. 8, 1862. }

*To the People of Maryland:*

It is right that you should know the purpose that has brought the army under my command within the

limits of your State, so far as that purpose concerns yourselves.

The people of the Confederate States have long watched with the deepest sympathy the wrongs and outrages that have been inflicted upon the citizens of a Commonwealth allied to the States of the South by the strongest social, political, and commercial ties, and reduced to the condition of a conquered province.

Under the pretence of supporting the Constitution, but in violation of its most valuable provisions, your citizens have been arrested and imprisoned, upon no charge, and contrary to all the forms of law.

A faithful and manly protest against this outrage, made by a venerable and illustrious Marylander, to whom in his better days no citizen appealed for right in vain, was treated with scorn and contempt.

The government of your chief city has been usurped by armed strangers; your Legislature has been dissolved by the unlawful arrest of its members; freedom of the press and of speech has been suppressed; words have been declared offences by an arbitrary decree of the Federal executive; and citizens ordered to be tried by military commissions for what they may dare to speak.

Believing that the people of Maryland possess a spirit too lofty to submit to such a government, the people of the South have long wished to aid you in throwing off this foreign yoke, to enable you again to enjoy the inalienable rights of freemen, and restore the independence and sovereignty of your State.

In obedience to this wish, our army has come among you, and is prepared to assist you with the power of its arms in regaining the rights of which you have been so unjustly despoiled.

This, citizens of Maryland, is our mission so far as you are concerned. No restraint upon your free will is intended—no intimidation will be allowed within the limits of this army at least. Marylanders shall once more enjoy their ancient freedom of thought and speech. We know no enemies among you, and will protect all of you in every opinion.

It is for you to decide your destiny freely and without constraint. This army will respect your choice, whatever it may be; and, while the Southern people will rejoice to welcome you to your natural position among them, they will only welcome you when you come of your own free will.

R. E. LEE, General Commanding.

On the 10th Gen. Lee began to evacuate Frederick, and by the 12th his entire force had left. His forces moved in the direction of Hagerstown. That same night the city was occupied by the advance of Gen. McClellan's army, under Gen. Hooker.

On the afternoon of the 10th, Hagerstown was entered by a Confederate force. On the 6th and 7th the banks of the town, anticipating this approach, removed their specie to Harrisburg and other places east for safety. The Government stores there were also removed.

Meantime, on the first approach of the Confederate army across the Potomac, the greatest excitement prevailed in Pennsylvania, especially in York and Adams counties, and through the Susquehanna and Cumberland valleys. The farmers sent away their wives, children, and cattle, and hastened to take up arms. In many of the towns of the State stores were closed, bells rung, guns fired, public meetings held, and citizens in their excitement assembled in mass to drill. On the 10th Gov. Curtin issued an order calling upon all the able bodied men of Pennsylvania to organize immediately for the defence of the State, and to be ready

for marching orders upon an hour's notice. On the 11th he issued a call for fifty thousand of the freemen of the State to enter immediate service to repel the imminent danger of invasion. On the same day he addressed the following despatch to the mayor of Philadelphia:

We have reliable information this evening that the rebel generals have moved their entire army from Frederick to Cumberland Valley, and their destination is now Harrisburg and Philadelphia. We need every available man immediately. Stir up your population to-night. Form them into companies, and send us twenty thousand to-morrow. No time can be lost in massing a force on the Susquehanna to defend the State and your city. Arouse every man possible and send him here.

Gov. Bradford, of Maryland, also issued a proclamation calling upon the citizens to organize without delay such a force as might effectually assist in defending their homes and firesides. The effect of these appeals, especially in Pennsylvania, was to bring to the governor a response from more than seventy-five thousand men. Harrisburg, the capital, overflowed with troops. The excitement, however, was not confined to Pennsylvania. In the adjacent States, troops under the first call for three hundred thousand men were hurried to Washington and to Harrisburg. It created another military excitement, and volunteers promptly came forward in all the States to fill up the call of the President.

On the 2d of September, the following order was issued by the general-in-chief:

WAR DEPARTMENT, ADJUTANT-GENERAL'S OFFICE, }  
WASHINGTON, September 2, 1862. }

*General Orders, No. 122.*

Maj.-Gen. McClellan will have command of the fortifications of Washington, and of all the troops for the defence of the capital.

By command of Maj.-Gen. HALLECK.

E. D. TOWNSEND, Assist. Adj.-Gen.

When Gen. McClellan arrived at Washington from Harrison's Landing, he was in the department of Gen. Pope, which included the District of Columbia. This was about the middle of August. Subsequent to that time he was without a command, excepting a body of ninety-six men, until this order was issued. Each corps of his army had been sent forward to Gen. Pope. In fact the active forces under the command of Gen. Pope consisted of the Army of Virginia, embracing the corps of Gens. McDowell, Banks, Sigel, a portion of Gen. Cox's force from western Virginia, a part of Gen. Burnside's force from North Carolina, about ten regiments from Port Royal in South Carolina, under Gen. Stevens, and the Army of the Potomac, consisting of the corps of Gens. Heintzelman, Sumner, Porter, and Franklin, and the divisions of Gens. McCall and Couch, without including the troops stationed in the fortifications around Washington. With this force he was not able to withstand the overwhelming march of the Confederate army. Yet this same Confederate army was the force which the Army of the Potomac, under Gen. McClellan, single handed and unaided, was re-

quired to meet and conquer, and thus obtain the capital of the Confederacy, which was in their possession. In this unequal struggle no dishonor ever tarnished the Army of the Potomac.

On the 4th of September, Gen. McClellan, having received the order above stated, issued another assuming command of the forces above mentioned, together with some new levies which had arrived at Washington under the call of the President for three hundred thousand men. His order assuming the command acted like an electric shock upon these dispirited, defeated masses. It was as follows:

HEADQUARTERS, WASHINGTON, Sept. 4, 1862.

*General Orders, No. 1.*

1. Pursuant to General Orders No. 122, from the War Department, Adjutant-General's Office, of the 2d instant, the undersigned hereby assumes command of the fortifications of Washington and of all troops for the defence of the capital.

2. The heads of the staff departments of the Army of the Potomac will be in charge of their respective departments at these headquarters.

3. In addition to the consolidated morning reports required by circular of this date from these headquarters, reports will be made by corps commanders as to their compliance with the assignment to positions heretofore given them, stating definitely the ground occupied and covered by their command, and as to what progress has been made in obedience to orders already issued to place their commands in condition for immediate service. GEO. B. McCLELLAN, Maj.-Gen.

Official: S. WILLIAMS, Assist. Adj.-General.

It was now known that Gen. Lee had marched into Maryland, and the orders given to Gen. McClellan were to pursue him with all the troops which were not required for the defence of Washington. On the next day most of his army was in motion, and rapidly advanced into Maryland. Gen. Couch's division, consisting of three brigades, commanded by Gens. Howe, Devens, and Cochrane, on the morning of the 6th had reached the road from Rockville to Great Falls, eight miles beyond Tenallytown. Other corps were rapidly pressing on. Three days after assuming command, on the 7th, at six p. m., he left Washington to take the field. That night he passed through Rockville, fifteen miles from Washington, stopping only long enough to refresh his horses. On the morning of the 10th, the army had advanced to Damascus, thirty-four miles from Washington and sixteen miles from Frederick. The first movements of the army were such as to occupy positions which commanded all the lower fords of the Potomac, thus presenting to the Confederate army the alternative of meeting him in battle, or retiring before him, and crossing the Potomac higher up, which would take them further from Washington, and oblige them to retreat through the Shenandoah Valley.

Meantime Gen. Lee, after his successes against Gen. Pope, had no reason to apprehend that the same army would soon be in pursuit of him; yet, like a prudent commander, he, upon learning of the approach of Gen. McClellan, immediately took precautions to secure his own safety. His army had met with no such

welcome from the citizens of Maryland as to give any hope that the State would, under any circumstances, rise in opposition to the Federal Government. On the contrary the people had shown that it was the Government of their choice. Very few recruits had joined the Confederate army, and no contributions of importance had been made to it. The following is a copy of Gen. Lee's order of march, found at Frederick, on the 13th of September. It discloses his plans:

[CONFIDENTIAL.]

HEADQUARTERS, ARMY OF NORTHERN VIRGINIA, }  
Sept. 9, 1862. }

*Special Order, No. 191.*

III. The army will resume its march to-morrow, taking the Hagerstown road. Gen. Jackson's command will form the advance, and after passing Middletown with such portion as he may select, take the route toward Sharpsburg, cross the Potomac at the most convenient point, and by Friday morning take possession of the Baltimore and Ohio railroad, capture such of the enemy as may be at Martinsburg, and intercept such as may attempt to escape from Harper's Ferry.

IV. Gen. Longstreet's command will pursue the main road as far as Boonsboro', where it will halt with reserve, supply, and baggage trains of the army.

V. Gen. McLaws, with his own division and that of Gen. R. H. Anderson, will follow Gen. Longstreet, on reaching Middletown will take the route to Harper's Ferry, and by Friday morning possess himself of the Maryland Heights, and endeavor to capture the enemy at Harper's Ferry and vicinity.

VI. Gen. Walker with his division, after accomplishing the object in which he is now engaged, will cross the Potomac at Check's Ford, ascend its right bank to Lovettsville, take possession of Loudon Heights, if practicable, by Friday morning, keep the ford on his left, and the road between the end of mountain and the Potomac on his right. He will, as far as practicable, cooperate with Gen. McLaws and Gen. Jackson in intercepting the retreat of the enemy.

VII. Gen. D. H. Hill's division will form the rear guard of the army, pursuing the road taken by the main body. The reserve artillery, ordnance, and supply trains will precede Gen. Hill.

VIII. Gen. Stuart will detach a squadron of cavalry to accompany the commands of Gens. Longstreet, Jackson, and McLaws, and with the main body of the cavalry will cover the route of the army, and bring up all stragglers that may have been left behind.

IX. The commands of Gens. Jackson, McLaws, and Walker, after accomplishing the objects for which they have attached [been detached?], will join the main body of the army at Boonsboro' or Hagerstown.

X. Each regiment on the march, will habitually carry its axes in the regimental ordnance wagons for use of the men at their encampments to procure wood, &c.

By command of Gen. R. E. LEE.

(Signed) R. H. CHILTON, A. A.-General.  
For Maj.-Gen. D. H. HILL, Comd'g Division.

It is clear from this order that Gen. Lee intended first to capture the garrison at Harper's Ferry, and then to enter Pennsylvania by the Cumberland Valley; at all events, that he had no idea of abandoning Maryland until forced to do so by the battles of South Mountain and Antietam. He evacuated Frederick, and taking the road to Hagerstown crossed the Catoctin Mountains, passed through the valley in which Middletown is situated, and drew up his forces along the crest of South Mountain there to await the advance of Gen. McClellan. At the same time he detached a portion of his force, amount-

ing to twenty-five thousand men, and sent them to Harper's Ferry by the route of Williamsport, where they crossed the Potomac. The chief command of this force was given to Gen. Jackson. It embraced his division with those of Gens. A. P. Hill and Walker, and one or two others. By this route, although longer, they were more certain to reach Harper's Ferry without the knowledge of the Federal Government than if their movement had been more direct. The distance from Frederick to Williamsport was thirty miles, and from Williamsport to Harper's Ferry thirty miles.

The advance of Gen. McClellan entered Frederick on the 12th, and he immediately sent forward cavalry and artillery to follow and harass the Confederate rear. Gen. Pleasanton was in command of the cavalry, and several skirmishes took place during the succeeding days. The line of the Federal army extended from the Potomac river in the region of Point of Rocks in a northeasterly direction to the region near Frederick, and thence in an easterly and southerly direction along the Baltimore and Ohio railroad to Baltimore. On Saturday the 13th, the main column of Gen. McClellan's army reached Frederick, and was received with the highest demonstrations and encamped two miles beyond. The same afternoon the Confederate rear was driven by his advance out of Middletown, which was held by the latter during the night. West of Frederick and running nearly due south is the Catoctin range of mountains, a continuation of the Blue Ridge. On the south it terminates in Maryland at Point of Rocks, but still continues in Virginia. On the north it unites at the Pennsylvania State line with the South Mountain range, which, tending to the southwest, slopes down to the Potomac at Knoxville four miles east of Harper's Ferry. Between these two ranges, nestles the loveliest valley in Maryland—the valley of Catoctin. The village of Middletown, ten miles from Frederick, is in the centre of this valley. On Sunday morning, the 15th, the Confederate army were found posted on the east side of the South Blue Ridge Mountain and stretching on a line from north to south from points immediately opposite Middletown and Jefferson, both of which villages are about eight miles from Frederick. Middletown is on the road to Hagerstown and Jefferson on the direct road to Harper's Ferry. The right of the Federal army, at that time under Gen. Burnside, rested on Middletown, and the left under Gen. Franklin on Jefferson. Early in the morning, the advance beyond Middletown overtook the Confederate rear, who retreated slowly, contesting the road toward Boonsboro' step by step. The conflict that ensued during the morning was chiefly with artillery, and came to closer quarters in the afternoon. At this time the Confederate line of battle was formed with the left resting upon Turner's Gap and the turnpike road toward Hagerstown which passes through the gap, and the right covering Crampton's Gap.

Preparations for moving the main body of the Federal army had commenced at daylight, and shortly after the whole army was advancing rapidly toward the mountains followed by the ambulances, artillery, and baggage wagons. Middletown was reached with ease, beyond which was now the scene of conflict. As they approached the field the long black lines of infantry were halted and opened to make way for the artillery and ammunition trains which advanced to their positions.

The battle of South Mountain really commenced at a bridge over Catoctin Creek half a mile west of Middletown, where Confederate artillery had been posted to dispute the passage. Dislodged from this position it retreated to a stronger one up the mountain side. The main body was massed on wooded bluffs to the right and left for a distance of more than two miles. On the right of Turner's Gap they were stormed out of their stronghold by Gen. Burnside's corps. Gen. Cox's Kanawha division in Gen. Reno's corps, attacked and carried the crest on the left of the gap. Of this division, the 23d Ohio, known as the "psalm singers of the Western Reserve," here came in contact with the 23d South Carolina, and the encounter was most stormy. So desperate were the Carolinians in the fight that before a single man surrendered he would beat his gun against a rock or tree to render it useless to his enemy. The Kanawha division was supported by the divisions of Gens. Wilcox, Rodman, and Sturgess. After very severe fighting they repulsed several attacks of the enemy, and retained entire possession of the crest. About 3 P. M., Gen. Hooker attacked the heights on the right of the pass, the Pennsylvania reserves leading, and after a desperate resistance carried the crest about dark, and held it. Shortly before dark Gen. Gibbon's brigade of Gen. Hooker's corps, attacked by the main road, and after an obstinate conflict gained the entrance to the pass some time after dark. Only by a display of equal valor in all the other regiments, and often at close quarters, was the enemy driven over the crest of the mountain into the valley on the west side of the South Mountain. In the centre and on the left, equally desperate was the battle. A severe fire of artillery had been opened all along the front. Under cover of this, the infantry advanced, and poured in a fire of musketry; this continued until 8 o'clock P. M. when the battle raged at its height. Success being soon gained on the right, desperate charges were made with the bayonet before which the Confederate troops wavered, broke, and fell back in confusion. The loss sustained by the Union forces was 2,325 killed and wounded. Among the killed was Gen. Reno, who was shot through the body. Turner's Gap, where the last desperate stand of the Confederate force on the right was made, is two miles from the base of the mountain. Six miles south is Crampton's Gap, through which passes the road from Jefferson to Roherville. This

strong position on the left was carried by Gen. Franklin's corps, after a succession of brilliant bayonet charges. Gen. Franklin had followed the line of the Potomac closely. On Saturday he reached Sugar Loaf Mountain, and drove out the Confederate cavalry occupying it for a signal station. On Sunday, he passed through the small village of Burkitsville, and advanced about a mile, when he met the Confederate pickets at the South Mountain range, and near Crampton's Gap. The gap was strongly held by a Confederate force under Gen. Howell Cobb, and his artillery immediately opened fire upon the Federal advance, which was under the command of Gen. Slocum. The division of Gen. Slocum consisted of three brigades under Gens. Bartlett, Tollitt, and Newton. These were formed in line of battle and ordered to advance up the side of the mountain. They had proceeded only a short distance before they came under the fire of a strong Confederate force concealed behind a stone wall running along the base of the gap. At this point a desperate hand to hand fight ensued which lasted nearly an hour, when the Confederate troops were routed. They did not attempt to make a stand again until they reached the crest of the mountain, where they turned and prepared to hold the Federal advance at bay. It came rushing up, composed of New Jersey, New York, and Pennsylvania regiments, until the top of the mountain was gained, when another bloody struggle ensued. The Confederate force finally gave way and fell back in disorder down into the valley, leaving four hundred prisoners, three regimental colors, two pieces of artillery, and three thousand stand of arms. The Federal loss in this affair was one hundred and five killed, and four hundred and forty-eight wounded. The Confederate loss was still larger. The seizure of this gap exposed the flank of Gen. Lee's army, and brought the Federal left into Pleasant Valley, and within five miles of Harper's Ferry. That night the Federal army occupied the battle ground, and the Confederate army fell behind Antietam Creek and took a position admirably adapted for defence.

Meantime the Federal garrison at Winchester and Martinsburg had been ordered to Harper's Ferry, and the commanding officer at that post had been advised to confine his defence, in case he was attacked by a superior force, mainly to the position of Maryland Heights, which could be held a long time against overwhelming numbers. A large amount of artillery and stores had been collected at Harper's Ferry by the Federal Government, which it would have been necessary to destroy or leave to the enemy if the troops there had been withdrawn. It was therefore determined by the general-in-chief (Halleck) to hold the position until Gen. McClellan could relieve it, or open communication so that it could be evacuated in safety.

On Friday, the 12th of September, two days before the battle of South Mountain, the Confed-

erate force of Gen. Jackson, which had been ordered to Williamsport and thence to Harper's Ferry, commenced an attack on Maryland Heights. As early as the 15th of August Col. Miles, then in command, received orders from Gen. Wool, commanding the department, to fortify Maryland Heights, which is considered to be the key of the position. He, however, disobeyed the orders, and did nothing to improve its defences. On the 5th of September Col. Thomas H. Ford took command of the force stationed on the heights, and, apprehending an attack from the Confederate army, sent a requisition to Col. Miles for reinforcements and for tools necessary to erect defensive works. He received reinforcements, but not the tools; and with a few borrowed axes constructed a slight breastwork of trees near the crest of the hill on the same day upon which the advance of Gen. Jackson appeared. The forces at Harper's Ferry had been increased that day to about thirteen thousand men, of whom twenty-five hundred were cavalry, by the arrival of Gen. Julius White with the garrison from Martinsburg. Gen. White, although entitled to the command, waived his right in favor of Col. Miles. The only position fortified by Col. Miles was Bolivar Heights behind the town of Harper's Ferry. This is commanded by Maryland Heights and by Loudon Heights situated on the Virginia side of the Potomac and on the right bank of the Shenandoah.

The attack of the Confederate force was renewed, on the morning of the 18th, on the forces stationed on Maryland Heights, and they were driven behind the breastwork. This was soon after attacked, and the enemy were repulsed. Subsequently, through the precipitate flight of a portion of the troops and the premature retreat of the remainder, in consequence of a mistake of orders, the heights were about midday entirely abandoned. Col. Miles, who had visited the position early in the morning, left Col. Ford with permission to exercise his discretion in determining whether to hold or abandon the heights. Subsequently Col. Miles sent to him the following order.

HARPER'S FERRY, Sept. 18, 1862.

*Col. Ford, Commanding Maryland Heights:*

Since I returned to this side, on close inspection I find your position more defensible than it appears when at your station, covered as it is at all points by the cannon of Camp Hill. You will hold on, and can hold on until the cows' tails drop off.

Yours, D. S. MILES, Col. 21st Infantry.

The answer of Col. Ford to this order, as stated by Col. Miles, did not indicate that he had the slightest intention of giving up the heights.

Col. Ford, after the events above mentioned, disobeyed this order of Col. Miles, abandoned the position, and withdrew his forces across the river. It was only necessary, after this disgraceful retreat, for the enemy to plant their batteries and the position of Harper's Ferry must surely fall. The heights were not, however, immediately occupied by the enemy, and

on the next morning a detachment of the 89th volunteers, sent there by Col. D'Utassy, returned with four field pieces and a wagon load of ammunition. On the 18th the Confederate force began to establish batteries on Loudon Heights, and on the next day opened fire from those heights and also from Maryland Heights. On the night of the 18th, Col. Miles sent a despatch to Gen. McClellan that the position could not be held forty-eight hours longer without reinforcements. This was the night before the battle of South Mountain. On the night of the 14th, the cavalry force under Col. Davis cut their way through the enemy's lines and reached Greencastle, Penn., in safety on the next morning, having captured by the way an ammunition train belonging to the corps of the Confederate general Longstreet. Early in the morning of the 15th Col. Miles surrendered. At that time Gen. McClellan's left wing was in Pleasant Valley, within five miles of him. It has been stated that the ammunition for the batteries was nearly exhausted, and for this reason the place became no longer tenable. The enemy, not perceiving the white flag that had been raised, continued their fire some time afterward, by which Col. Miles was mortally wounded by the fragment of a shell. The principal fighting took place on Saturday; there was very little on Sunday, and none worthy of mention on Monday, when the surrender took place. The military mistake was in abandoning Maryland Heights. No enemy could have occupied the village, or disturbed the railroad or pontoon bridges so long as they were held. Provisions and forage for a siege of four or five days could have been readily transferred to the heights by a road made some months previous. There are abundant springs of good and cool water gushing out from its rocky and wooded sides. When these and the other heights came into the possession of the enemy, surrender or destruction were the only alternatives to Col. Miles. If his entire force had been transferred to Maryland Heights, the Confederate force present could not for many days have taken Harper's Ferry. By the terms arranged for the surrender, the officers were allowed to go on parole with side arms and private property, and the privates with everything except equipments and guns. The forces which surrendered were as follows:

Col. Downye, 8d Maryland Home Brigade.....	600	65th Illinois.....	850
Col. Maulsby, 1st Maryland Home Brigade.....	900	Graham's battery..	110
115th New York...	1,000	McGrath's battery.	115
120th New York...	1,000	15th Indiana batt'y.	142
89th New York....	530	Phillips's N. Y. battery.....	120
111th New York...	1,000	Potts's battery....	100
125th New York...	1,000	Rigby's battery .	100
82d Ohio.....	654	Scott's companies.	50
12th New York S.M.	504	Officers connected with Headquarters and Commissary Department	50
37th Ohio.....	900		
9th Vermont.....	800	Total.....	11,583

The following guns were surrendered: 12

2-inch rifled, 6 James's rifled, 6 24-pound howitzers, 4 20-pound Parrott guns, 4 12-pounders, 4 12-pound howitzers, 2 10-inch Dahlgrens, 1 50-pound Parrott, and 6 6-pound guns.

The Federal loss in killed and wounded was reported at about two hundred; the Confederate loss has not been stated. In the latter part of the year the circumstances attending this surrender were examined by a court of inquiry at Washington, in accordance with whose suggestions Col. Ford and other officers were dismissed from the United States army. The conduct of Col. Miles was stated in their report to have exhibited "an incapacity amounting almost to imbecility."

The surrender of this position with so little resistance was followed by serious consequences. It took place on the 15th. On the next day, the 16th, most of the Confederate force left it in great haste, crossed the pontoon bridge into Maryland, and joined Gen. Lee at Antietam in time to engage in the great battle on the next day, the 17th. Without the assistance of this force Gen. Lee's army would undoubtedly have been badly defeated and his retreat into Virginia probably cut off. That the importance of their aid was known to their commander, is manifest from the haste of the evacuation and the subsequent celerity of their movements. By their arrival the Confederate army outnumbered the Federal army in the battle of Antietam.

The battle on which was staked "the invasion of Maryland" in the view of the Federal, and "the deliverance of Maryland" in the view of the Confederate Government, but in reality the sovereignty of the Union, was now near at hand.

On the morning of the 15th the whole right wing and centre of Gen. McClellan's forces were pushed forward in pursuit of the enemy, who were found in the strong position made memorable by the battle of the Antietam. The troops were not up in sufficient force to make the attack on that day; but soon after night fell the greater part were in bivouac behind the heights on the left bank of the Antietam, sheltered from, but within range of the enemy's batteries.

On the left the three divisions of Gen. Franklin were ordered to occupy Roherville, and to push in the direction of Brownsville in order to relieve Harper's Ferry if possible. During the morning Gen. Franklin received intelligence of the surrender of Harper's Ferry, and found the enemy in force in a strong position near Brownsville. As he had but two divisions with him, the third not having yet arrived, he was not in sufficient force to dislodge the enemy, and was obliged to content himself with watching them and endeavoring to hold them in check.

The morning of the 16th was occupied in reconnoissances of the enemy's position, in rectifying the position of the Federal troops, and perfecting the arrangements for the attack. Very sharp artillery firing took place without

any material loss on the Federal side. The position of Gen. McClellan's forces on that morning was as follows: Gen. Hooker's corps was on the right, next that of Gen. Sumner, with Gen. Mansfield's corps in the rear; in the centre was Gen. Porter's corps, only two divisions being present; on the left was Gen. Burnside's ninth corps. Gen. Franklin was still in Pleasant Valley.

At about 3 P. M., Gen. Hooker crossed the Antietam by the bridge in the village on the Hagerstown road and an adjacent ford, and soon gained the crest of the height on the right bank of the stream. He then turned to his left and followed down the ridge under a strong opposition, until brought to a stand still by the darkness. During the evening Gen. Mansfield was ordered to follow Gen. Hooker so as to be in a position to support him at daybreak.

At daylight on the 17th, Gen. Hooker attacked the forces in his front, and for a time drove them before him. The enemy however rallying, and strengthened from their supporting columns, repulsed him. Gen. Mansfield's corps was then drawn to Gen. Hooker's support, and the two masses repelled the enemy. Gen. Mansfield was killed and Gen. Hooker wounded at this crisis, and obliged to withdraw from the field. Shortly afterward Gen. Sumner's corps reached this portion of the field and soon became hotly engaged. This corps suffered greatly at this period of the contest, Gens. Sedgwick and Crawford being wounded, and portions of the line were compelled to fall back. The enemy were here, however, checked by the Federal artillery. Gen. Franklin shortly arrived to the relief of Gen. Sumner's line with two divisions of his corps, one of which, that of Gen. W. F. Smith, drove back the enemy and recovered the lost ground. The enemy did not retake it. Gens. Richardson's and French's divisions held the extreme left of the Federal right with tenacity during the day. Gen. Richardson was wounded.

In the centre Gen. Porter's corps was held as a reserve with cavalry and horse artillery.

The contest on the right had been most obstinate, and the several corps which participated in it had lost heavily.

Gen. Burnside's corps on the left was ordered early in the day to carry the bridge across the Antietam at Rohrback's farm, and to attack the enemy's right. The approaches to the bridge being in the nature of a defile, and being swept by batteries of the enemy, the opposite bank of the Antietam was only reached after a severe struggle. It was afternoon before the heights were in his possession. The enemy were driven back, and a portion of their line in disorder. By the most desperate efforts, however, the enemy rallied their retreating regiments, strengthened their line with all their available fresh troops, and opened batteries on the hills, from positions which the amphitheatrical character of the ground, it seems, abundantly furnished. Gen. Burnside

could not maintain his advantage, and was obliged to withdraw from the extreme position which he had gained near Sharpsburg to one slightly in rear of it. He, however, held his bank of the river completely, and maintained much ground beyond it which he had taken from the enemy. During the advance on the left Gen. Rodman was wounded.

The Federal artillery is represented to have played an important part during this battle.

Notwithstanding substantial and decided successes of the day, the Federal forces had suffered so severely during the conflict, having lost 11,426 in killed and wounded, and among them many general and superior officers, that it was deemed prudent by Gen. McClellan to reorganize and give rest and refreshment to the troops before renewing the attack. The 18th was accordingly devoted to those objects. On the night of the 18th, however, Gen. Lee withdrew his forces hastily across the Potomac, abandoning further contest with the Union forces, and yielding all hope of further remaining on the Maryland soil.

The Confederate army is supposed to have lost nearly 30,000 men during its brief campaign in Maryland. The Federal forces captured 39 colors, 13 guns, more than 15,000 small arms, and more than 6,000 prisoners.

On the 20th, Harper's Ferry was evacuated by the Confederate troops, which fell back in the direction of Charlestown and Winchester. Gen. McClellan took a position along the left bank of the Potomac, and active movements were suspended for a short time in order to prepare for a vigorous advance.

Early in June the guerilla operations became troublesome in some of the lower counties of Kentucky. At Madisonville, in Hopkins county, a descent was made by a small body of them at night. The county clerk's office was broken open and the records of the court carried off or destroyed. In other cases horses and other property were taken. Their own friends, equally with Union citizens, were robbed. In Jessamine, Mercer, Boyle, and Garrard counties bridges over the streams were burned. On the 5th of July Lebanon was taken. It is at the termination of the Lebanon branch of the Louisville and Nashville road. About the same time Murfreesborough in Tennessee was captured by a strong guerilla force under Col. Forrest. Vigorous opposition was however made by the small body of Federal troops stationed there. The 9th Michigan regiment, however, was captured entirely by surprise, with Brig.-Gens. Duffield and Crittenden, of Indiana. On the 18th of July an attack was made by Col. John Morgan on a small Federal force stationed at Cynthiana, Ky. Subsequently he was overtaken near Paris by Gen. Green C. Smith and defeated. About the same time Henderson was occupied by citizens of Kentucky and other States, acting the part of guerillas, and the hospital and other stores carried off. At the same time, Newburg,

in Indiana, on the Ohio river, was occupied by a band from Kentucky. They soon, however, left. The activity of the bands under Col. Morgan produced a great excitement in the interior of the State. Many towns were visited and much plunder obtained. It had been his conviction that large numbers of the citizens would flock to his standard. In this he was greatly mistaken, and the indifference and hostility of the people, together with the preparations to resist him, checked his movements. Active operations continued in Tennessee, whither Col. Morgan retired. Clarksville was captured with large military stores, and about the 22d of August a considerable body of Confederate cavalry attacked the Federal force at Gallatin, and after a severe contest repulsed the latter.

The increase of guerilla operations in Kentucky about the 1st of September, with the manifestations of the existence of a Confederate force, indicated some hostile movements. It was soon known that the Confederate general E. Kirby Smith was approaching from Knoxville in Tennessee. On the 22d of August he left Jacksborough with a train of one hundred and fifty wagons, and passed through Big Creek Gap. So difficult were some parts of the route in Tennessee that for two or three days the rear of the trains was only able to reach at night the point from which the advance started in the morning. Rations failed, and the men were obliged for several days to subsist on green corn. Hungry, thirsty, footsore, and choking with dust, his men marched steadily on to a land of plenty. The ordnance stores were brought safely through without the loss of a wagon. On Saturday, August 30, a battle took place between his forces and a Federal force near Richmond, Ky., in which the latter were defeated. Richmond is the capital of Madison county, situated about fifty miles south-southeast of Frankfort, the capital of the State. The Federal force there consisted of one Ohio regiment and five Indiana regiments and part of a sixth, two Kentucky regiments, all raw troops, and a squadron of Kentucky cavalry, under the command of Brig.-Gens. Mahlon D. Manson and Crufts, with nine field pieces. It made an attack upon this Confederate column under Gen. Smith at Rogersville about four miles from Richmond, and after a severe battle, continuing from six o'clock in the morning until night, it was entirely defeated, with a large number killed and wounded and with the loss of eight field pieces. Gen. Nelson, who had come from Lexington, arrived at the commencement of the retreat, and endeavored to rally the troops, was wounded and obliged to retire. At that time the Legislature of the State was in session, and it met on Sunday evening, and passed resolutions adjourning to Louisville, &c. The archives of the State and about one million of treasure from the banks of Richmond, Lexington, and Frankfort were transferred during the night to Louisville.

At the same time the governor of the State issued the following proclamation :

FRANKFORT, KY., August 31, 1862.

*To the People of Kentucky:*

A crisis has arisen in the history of the commonwealth which demands of every loyal citizen of Kentucky prompt and efficient action. The State has been invaded by an insolent foe, her honor insulted, her peace disturbed, and her integrity imperilled. The small but gallant army, raised upon the emergency of the occasion for her defence, under the brave and chivalric Nelson, has met with a temporary reverse, and the enemy is advancing for the accomplishment of his purpose—the subjugation of the State. He must be met and driven from our border, and it is in your power to do so. I, therefore, as Governor of the Commonwealth, deem it my duty to call upon every loyal citizen of Kentucky to rally to the defence of the State; not a moment is to be lost. I appeal to you as Kentuckians, as worthy sons of those who rescued the dark and bloody ground from savage barbarity, by the memories of the past of your history, and by the future of your fame, if you are but true to yourselves, to rise in the majesty of your strength and drive the insolent invader of your soil from your midst. Now is the time for Kentuckians to defend themselves. Each man must constitute himself a soldier, arm himself as best he can, and meet the foe at every step of his advance. The day and the hour, the safety of your homes and firesides, patriotism and duty, alike demand that you rush to the rescue. I call upon the people, then, to rise up as one man, and strike a blow for the defence of their native land, their property, and their homes. Rally to the standard, wherever it may be nearest, place yourselves under the commanders, obey orders, trust to your own right arm and the God of battle, and the foe will be driven back, discomfited and annihilated. To arms! to arms!! and never lay them down till the Stars and Stripes float in triumph throughout Kentucky. I but perform my duty in thus summoning you to the defence of your State, and I am assured that it will be promptly responded to. I promise that I will share with you the glory of the triumph which surely awaits you.

Done in the city of Frankfort, this 31st day of August, 1862.

(Signed) JAMES F. ROBINSON.

By the Governor,  
D. C. WICKLIFFE, Secretary of State.

On the 2d the Confederate advance guard entered Lexington. All the Government stores had been previously safely removed. The stock of horses and mules had also been sent off, and all the cars withdrawn from the railroad.

In explanation of the object of the invasion, Gen. Smith issued the following proclamation:

**KENTUCKIANS:** The army of the Confederate States has again entered your territory under my command.

Let no one make you believe we come as invaders, to coerce your will, or to exercise control over your soil. Far from it. The principle we maintain is, that government derives its just powers from the consent of the governed.

I shall enforce the strictest discipline, in order that the property of citizens and non-combatants may be protected. I shall be compelled to procure subsistence for my troops among you, and this shall be paid for.

Kentuckians: We come not as invaders, but liberators. We invoke the spirit of your resolutions of 1793. We come to arouse you from the lethargy which enshrouds your free thought, and forebodes the political death of your State.

We come to test the truth of what we believe to be a foul aspersion, that Kentuckians willingly join the attempt to subjugate us, and to deprive us of our property, our liberty, and our dearest rights.

We come to strike off the chains which are riveted upon you. We call upon you to unite your arms, and

VOL. II.—10 A

join with us in hurling back from our fair and sunny plains the Northern hordes who would deprive us of our liberty, that they may enjoy our substance.

Are we deceived? Can you treat us as enemies? Our hearts answer NO!

E. KIRBY SMITH,

Major-General C. S. A.

On the 6th Frankfort, the capital of the State, was quietly occupied by about fifteen hundred Confederate cavalry. The government of the city was reorganized, and recruiting stations opened. The guerilla force, under Col. Morgan, also joined Gen. Smith.

Meanwhile, on the first approach of the Confederate force toward Lexington, excitement commenced in Cincinnati, and preparations for defence began to be made. Gen. Lewis Wallace took command of Cincinnati, Covington, and Newport on the 1st of September. Martial law was declared, and on the next day all places of business in Cincinnati were ordered to be closed at nine o'clock in the morning, and the citizens were required to assemble at ten o'clock and organize for defence. The street railroad cars were stopped, and no male citizen was allowed to leave. Preparations to throw up intrenchments and to fortify the city were immediately commenced. This excitement extended into the interior of the State and into the adjoining State of Indiana. The governor of Ohio issued the following proclamation:

CINCINNATI, September 2, 1862.

*To the Loyal People of the River Counties:*

Our southern border is threatened with invasion. I have, therefore, to recommend that all the loyal men of your counties at once form themselves into military companies and regiments to beat back the enemy at any and all points he may attempt to invade our State. Gather up all the arms in the country, and furnish yourselves with ammunition for the same. The service will be of but few days' duration. The soil of Ohio must not be invaded by the enemies of our glorious Government. DAVID TOD, Governor.

About the 10th of June Gen. Buell left Corinth with the main body of his army for Chattanooga. On reaching Huntsville he appointed Gen. Rousseau to command the division of his army previously under Gen. Mitchell, and completely reorganized the state of affairs in that part of his department. Depredations by soldiers were stopped, discipline restored, and order established. His army then took positions at Battle Creek, Huntsville, and McMinnville. At the same time the Confederate general Bragg massed his army at Chattanooga and Knoxville. This was done by suddenly moving his force from Tupello, in Mississippi, through the States of Alabama and Georgia, and thus reaching Chattanooga in advance of Gen. Buell. It was divided into three corps under Maj.-Gens. Wm. J. Hardee, Leonidas Polk, and E. Kirby Smith, each of which numbered about fifteen thousand men. The two former of these officers had been at Corinth, and their forces consisted of some of the troops which evacuated that place, increased by new levies under the conscription law. The division of Gen. Smith was stationed at Knoxville, where it safely remained while Chattanooga was occupied by the corps of



Gens. Hardee and Polk. Gen. Smith moving from Knoxville succeeded in flanking the Federal general G. W. Morgan, and with no battle of any consequence, except at Tazewell, effected the design of getting into his rear, and thence advanced into Kentucky as above stated. The next movement was made by the other two corps, for the purpose of forming a junction with Gen. Smith after he had reached Lexington. Accordingly, on the 21st of August, Gen. Bragg crossed the Tennessee river at Harrison, a few miles above Chattanooga, and turning the left of Gen. Buell he marched westward by the mountain road to Dunlap, which he reached on the 27th. His force then consisted of five regiments of cavalry, thirty-six of infantry, with forty pieces of field artillery. Thence he moved up the Sequatchie Valley, and reached Pikeville on the 30th. On the same day he threw a large force forward toward McMinnville, the capital of Warren county, Tennessee, and seventy-five miles southeast of Nashville. The Confederate cavalry advanced far toward McMinnville, and one or two smart skirmishes took place with the Federal cavalry thrown forward from that point. In the mean time the rest of the Confederate army moved northeast toward Crossville, and on the 1st of September reached the mountains at that place, having ascended the Grassy Cave road, while the force thrown toward McMinnville was suddenly withdrawn, and followed the main army. On the 5th of September this Confederate force entered Kentucky, and moved on toward Bowling Green. On the 13th of September an advance of this force appeared before Munfordsville, at the crossing of the Louisville and Nashville railroad, over Green river, and demanded its surrender. Col. Wilder then in command refused, and early on the next morning an attack was made by the Confederate force, under Gen. Duncan, who after a struggle of seven hours was repulsed. The force at Munfordsville, which had been stationed there for the protection of the bridge, consisted of three thousand one hundred infantry with four pieces of artillery. The Federal loss was eight killed and twenty wounded. The Confederate loss was larger. The attack was renewed again on the 16th with great spirit, and on the next day the place was surrendered by Col. C. L. Dunham, who had arrived with his regiment, and then had command. The troops surrendered consisted of the 17th, 60th, 67th, 68th, 69th Indiana, a company of Louisville cavalry, a part of the 4th Ohio, and a section of the 18th Indiana battery; amounting in all to about four thousand five hundred men, and ten guns. The bridge over the Green river was burned at this time.

During this period Gen. Buell had not been idle. While on the Tennessee river, near Chattanooga, his army was dependent on Louisville as its base for the supply of provisions and munitions. To render this available it was necessary to protect over three hundred miles of

railroad, over which every pound of these supplies had to be transported. Every care which prudence could suggest was exercised to retain the command of this road. Stockades were built, and guards were stationed at the places most liable to attack, but they were not able

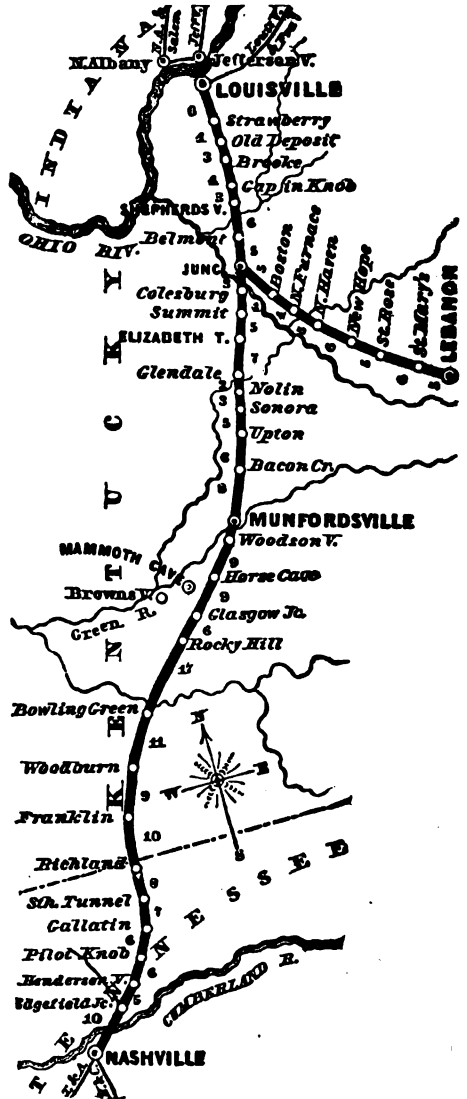

to resist the dashes of the Confederate cavalry, who in many cases were aided by the sympathies of the local residents. In the meanwhile the Confederate conscription act had been rigidly enforced, and a large army under Gen. Bragg was massed near Chattanooga, as above stated, the definite object of which was long unknown. For several weeks the utmost vigilance was exercised over the enemy at Dechard, McMinn-

ville, and the valley of the Sequatchie before it was assuredly ascertained where he intended to strike his blow. It was expected that Nashville was the point he desired to reach, but subsequent movements soon made it evident that was not the projected point of attack. Finally despatches to Gen. Bragg were intercepted, which proved conclusively that Louisville in Kentucky was the point toward which the Confederate strategy was directed. This was to be effected by forced marches of the Confederate force without supplies, subsisting on the country, and reaching the city when in a condition unprepared for defence. It was then intended to destroy the canal around the falls of the Ohio, to seize all the public stores, and to hold the city, under the impression that the Federal army would make no effort to recover it, for fear of injuring it by a bombardment.

While Gen. Bragg made his way slowly toward the Cumberland river, which he struck at Carthage, Gen. Buell was on his left flank, at Lebanon, guarding against his approach to the city of Nashville. The march of Gen. Bragg was commenced on the 21st of August, as above stated, and all the way he was felt by Gen. Buell, whose object was to guard the railroad as much as possible, and allow his enemy to get no distant start of him. All this time Gen. Buell was drawing his supplies from the depots, collecting at Nashville and Bowling Green; but Gen. Bragg was warmly received in many places, and bountifully supplied by friends. Gen. Buell harassed his rear as long as possible, shelled him out of Woodsonville, and forded the Green river and drove him out of Munfordsville, and followed him along the turnpike road from Nashville to Louisville, until the road through Hodgenville to the east was reached, into which Gen. Bragg's forces defiled. It was evident from the movement of Gen. Bragg that he was hurrying in a direction in which he expected to find Gen. E. K. Smith, Gen. Humphrey Marshall, and Col. Morgan with their forces, with whom he could unite and make a combined attack on Louisville. Gen. Buell, however, was forced by the need of supplies to move directly to the city, around which his army encamped.

The chief object of this Confederate movement upon the State of Kentucky was to obtain supplies of meat. There were more hogs and cattle in the State available for general consumption, two or three to one, than were left in all the South besides. The grain growing and provision raising country which stretched from the Potomac at Harper's Ferry to Memphis, on the Mississippi, was now exhausted of its provisions. Much of the productive portions of North Carolina, and of the Gulf States, were also exhausted, and a general scarcity existed. Wheat was two dollars and a half per bushel in the heart of a fine wheat country, and cattle sold for seven cents gross per pound in the chief cattle-raising region of the whole South.

Pork could not be had at an advance of four hundred per cent. At the same time it was thought that a powerful force might secure the State to the Southern Confederacy.

On the 18th of September Gen. Bragg issued the following address to the people of the State:

GLASGOW, KY., September 18, 1862.

Kentuckians! I have entered your State with the Confederate army of the West, and offer you an opportunity to free yourselves from the tyranny of a despotic ruler. We come, not as conquerors or despoilers, but to restore to you the liberties of which you have been deprived by a cruel and relentless foe. We come to guarantee to all the sanctity of their homes and altars; to punish with a rod of iron the despoilers of your peace, and to avenge the cowardly insults to your women. With all non-combatants the past shall be forgotten. Needful supplies must be had for my army, but they shall be paid for at fair and remunerating prices.

Believing that the heart of Kentucky is with us in our great struggle for Constitutional Freedom, we have transferred from our own soil to yours, not a band of marauders, but a powerful and well-disciplined army. Your gallant Buckner leads the van. Marshall is on the right, while Breckinridge, dear to us as to you, is advancing with Kentucky's valiant sons, to receive the honor and applause due to their heroism. The strong hands which in part have sent Shiloh down to history, and the nerved arms which have kept at bay from our own homes the boastful army of the enemy, are here to assist, to sustain, to liberate you. Will you remain indifferent to our call, or will you not rather vindicate the fair fame of your once free and caved State? We believe that you will, and that the memory of your gallant dead who fell at Shiloh, their faces turned homeward, will rouse you to a manly effort for yourselves and posterity.

Kentuckians! We have come with joyous hopes. Let us not depart in sorrow, as we shall if we find you wedded in your choice to your present lot. If you prefer Federal rule, show it by your frowns, and we shall return whence we came. If you choose rather to come within the folds of our brotherhood, then cheer us with the smiles of your women, and lend your willing hands to secure you in your heritages of liberty.

Women of Kentucky! Your persecutions and heroic bearing have reached our ear. Banish henceforth, forever, from your minds the fear of loathsome prisons or insulting visitations. Let your enthusiasm have free rein. Buckle on the armor of your kindred, your husbands, sons, and brothers, and scoff with shame him who would prove recreant in his duty to you, his country, and his God.

BRAXTON BRAGG,  
General Commanding.

From Munfordsville the Confederate force moved toward Bardstown, Glasgow, and the central part of the State. Thence guerillas in large and small bands scoured almost every other portion, penetrating in various places to the Ohio river, and even making dashes to within four or five miles of Louisville. Every day, during which they continued these operations, was estimated to afford them a gain of a hundred thousand dollars, and to bring a loss to the loyal people of at least two hundred thousand. Everything which could be of use to the army or to the Southern people was seized. Hundreds of drovers almost daily took away horses, cattle, and hogs, and almost interminable trains were hauling away bacon, pork, and all kinds of breadstuffs. Regarding Kentucky as belonging to the Confederacy,

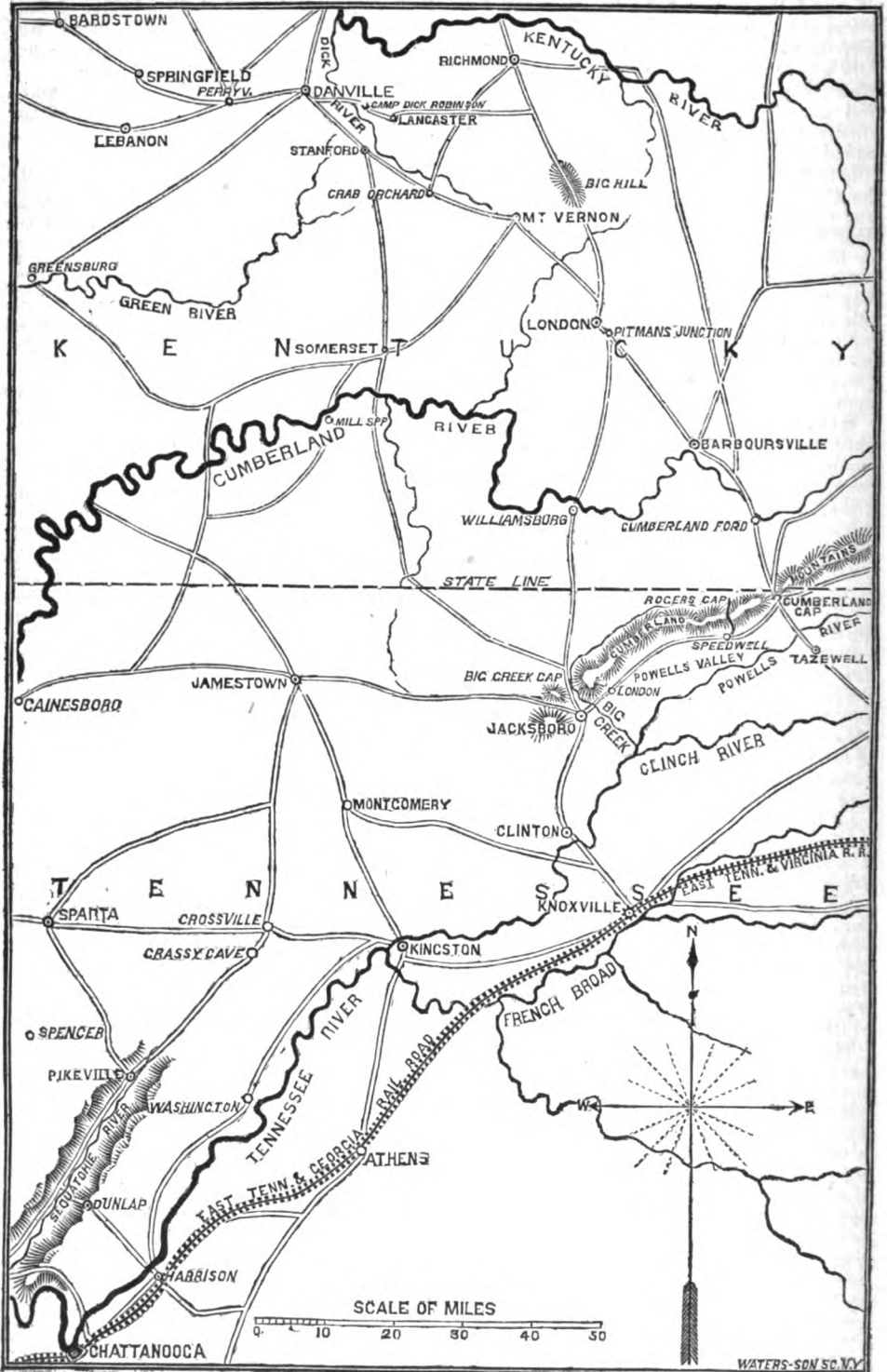

the conscription act was enforced, and men were forced into the ranks of the Confederate army by the point of the bayonet. The stores of the towns were ordered to be opened, and the goods taken and paid for in Confederate scrip.

On the 1st of October Gen. Buell, who had been previously removed from command and reinstated again, moved from Louisville, where he had lost thousands by desertion, to meet the Confederate force, and on the 4th his army arrived at Bardstown. On the previous day a force of Gen. Bragg had evacuated that place. This force consisted of about sixty-five regiments, averaging about three hundred men each, and amounting in total to twenty thousand. It moved from Bardstown in the direction of Springfield. The force of Gen. Buell was stated by the general-in-chief to number about one hundred thousand men. From the first approach of the Confederate forces, every effort had been made to collect new troops at Cincinnati and Louisville, and to fortify these places against a *coup de main*. To give confidence to the new levies, a portion of Gen. Grant's army was withdrawn from Mississippi and sent to Kentucky and Cincinnati.

The army of the Ohio, as Gen. Buell's force was designated, was now divided into three corps, commanded by Gens. Gilbert, Crittenden, and McCook. The new regiments sent to Louisville were placed in brigades with the old ones, which had seen nearly a year's service. On the march from Louisville the corps of Gen. McCook, forming the left wing, took the road to Taylorsville, Gen. Gilbert the road to Shepherdsville, and Gen. Crittenden, forming the right wing, the road to Bardstown. With the latter corps Gen. Buell moved.

On the 4th, Richard Hawes was inaugurated at Frankfort as Confederate Provisional Governor, and on the same day the city was evacuated, and he retired with the troops.

On the 6th the army of Gen. Buell arrived at Springfield, sixty-two miles from Louisville. Its slow progress had been owing to its numbers, the difficulty of the route and the conflicts with the Confederate rear guard. The main body of the Confederate army was twenty-four hours in advance when Gen. Buell left Louisville, and thus far had been constantly gaining. The order of Gen. Bragg to his rear guard was to prevent the arrival of Gen. Buell at Bardstown before the 4th, if possible, in order to give time to the Confederate wagon train to gain an advance of some twenty miles. Gen. Crittenden's corps only entered the place, and those of Gens. McCook and Gilbert kept on toward Springfield, retaining their position on the left and centre. Gen. Crittenden followed on the 5th. On the 7th it was reported to Gen. Buell that a considerable Confederate force was at Perryville, forty-two miles south of Frankfort. The three army corps were then marching on that place by different roads. Gen. Buell determined to surround the enemy, if possible,

and ordered all the divisions to march without delay, leaving behind their transportation. Gens. McCook and Gilbert continued their march, but Gen. Crittenden lost half a day on a circuitous route to obtain water. Gen. Bragg, learning of the united approach of the Union forces, immediately began to retreat. It was the design of Gen. Buell that the three corps should participate in the battle, but Gen. Bragg hearing of the delay of Gen. Crittenden, immediately determined to fight the corps of Gens. McCook and Gilbert, and defeat them if possible, and then to fall upon Gen. Crittenden or to retreat before his arrival. The Confederate general Hardee's corps, which had retreated six miles, was accordingly ordered back in haste to Perryville. Suddenly, on the 8th, Gen. McCook found himself in front of the Confederate line of battle, with his men marching in columns, and without skirmishers in advance, nothing in front but a small advance guard which attempted to attack the enemy's outpost. The Confederate infantry rushed forward and a division of raw troops had to be formed in line of battle under a heavy fire. The raw troops fled in confusion, but the old troops stood their ground. Gen. McCook had approached Perryville by the Knoxville road. Gen. Gilbert had marched direct from Springfield, and had arrived within two miles of Perryville on the preceding evening, the 7th. To Gen. McCook's request for reinforcements, they were ordered from Gen. Gilbert's corps. At the same time Gen. Crittenden was ordered to push forward on the Lebanon road to attack the Confederate left. The advance of Gen. Gilbert's reinforcements arrived at half-past three o'clock in the afternoon to support Gen. McCook on the left. His forces were found badly cut up and hotly pressed by the Confederate force, having retreated nearly a mile. The contest continued violent until dark, the Federal force retiring from the field. During the evening Gen. Crittenden's corps came up, but no movement was made till noon of the next day, when it was ascertained that the Confederate force had retired. The Federal loss was about four hundred and sixty-six killed, among whom were Brig.-Gens. Jackson and Tyrrell, fourteen hundred and sixty-three wounded, and one hundred and sixty missing. The Confederate loss was nearly the same. The forces of Gen. Bragg, which he had been able to draw from all quarters, were now about sixty thousand. The arrival of Gen. Crittenden's corps undoubtedly induced Gen. Bragg to continue his retreat. On that evening the Federal troops returned to Perryville.

It was now expected that Gen. Bragg would make a stand at Camp Dick Robinson. The position of this place is such that it can easily be defended against an approach in front by a few batteries on the cliffs which line Dick river. It, however, can be easily flanked. It was the plan of Gen. Buell, therefore, to make a feint in front and a strong attack on the flank of the Confederate position. Accordingly, Gen. Crit-

tenden was ordered to march to Dick river, giving the semblance of a contemplated attack in front. Gens. McCook and Gilbert were to approach by different roads, so as to cut off the escape of Gen. Bragg and leave to him no alternative but to fight or surrender. By the night of the 12th the entire army of the Ohio was within a mile of Danville, which is forty-two miles south of Frankfort, in one of the most fertile and highly improved parts of the State. But Gen. Bragg penetrated the designs of his antagonist in consequence of a retrograde movement by the advance of Gen. Crittenden's corps, under Gen. Wood, and determined to frustrate them. His spoils loaded heavily nearly four thousand wagons, a majority of which were branded with the letters U. S., having been captured during the year; in addition there were several thousand head of cattle, a thousand mules, and as many sheep.

The following statement from a highly credible source at Lexington, Ky., has been made of property taken by Gen. Bragg's forces :

We were here in Lexington and saw something of the removal of Government stores, and witnessed the plunderings of the Confederate armies of our dry-goods stores, groceries, &c. Upon the resumption of the publication of our paper ("Observer") we stated that an immense amount of Government stores, amounting perhaps to \$1,000,000, besides arms sufficient to arm eighteen or twenty thousand men, were taken off, and we stated precisely the truth, and there are hundreds here who will bear us out in the statement. We are not inclined to think the "Richmond Examiner" far wrong when it published that the "wagon train of supplies brought out of Kentucky by Gen. Kirby Smith was forty miles long, and brought a million yards of jeans, with a large amount of clothing, boots, and shoes, and 200 wagon loads of bacon, 6,000 barrels pork, 1,500 mules and horses, 8,000 beaves, and a large lot of swine."

From the city of Frankfort it is stated that 74,900 yards of jeans were taken from the establishment of Mr. Watson. From one concern in this city (Lexington) they took \$106,000 worth of jeans and linseys, from another \$10,000 worth, another \$9,000, another \$10,000, another \$5,000. These different amounts in woollen goods we know to have been removed from this city, as we have the names before us from whom they were taken. Aside from this, in boots, shoes, &c., we know of \$30,000 worth that they carried off, and also have the names to show from whom the goods were taken. From one house seven boxes of new Springfield rifles and nine boxes of muskets, with all the tents belonging to Metcalf's cavalry, forty kegs of horse shoes, and one hundred and twenty boxes belonging to four regiments, containing clothing and subsistence. The articles taken from this house were valued by the Confederates themselves at more than \$10,000, and they so declared at the time. The Adams Express office was robbed of everything it contained. All the goods that had been sent and deposited in the establishment from all parts of the country were seized and appropriated. For four weeks, during the stay of the enemy here, a train of cars were running daily to Nicholasville, bearing away mess pork and other articles necessary to the subsistence of armies, while trains of wagons—huge in number—were moving out on the Richmond, Versailles, and Nicholasville roads, day and night, loaded with valuable commodities. We were here and saw and know what occurred, and can prove what we assert. Lexington afforded the Confederates, when they entered it, the richest harvest they have reaped during the war, and nothing is to be made by disguising the fact.

On the night of the 11th the evacuation of Camp Dick Robinson commenced. The destination of Gen. Bragg was Cumberland Gap. Two routes for retreat were open to him, both leading to that point; one by the way of Richmond and Big Hill, through Madison county, and the other, called the Crab Orchard road, by the way of Mt. Vernon and Barboursville. These two roads converge at Pitman's Junction, twenty-two miles from Mt. Vernon, and fifty-eight miles from Cumberland Gap.

At midnight, on the night of the 12th, orders were received from the headquarters of Gen. Buell at Perryville, by the army encamped near Danville, for an immediate advance. Transportation of all kinds was ordered to remain behind. Only ambulances were to accompany the troops. Gen. Buell had been informed of the retreat of the Confederate army. At one o'clock the army was in motion toward Stanford, nine miles from Danville, a town through which it was supposed the Confederate force was then retreating. The march was rapid, and the advance arrived in time to see the rear of the Confederate rear guard pass unmolested. Two or three regiments of cavalry, one of which was the Texan Rangers, and two howitzers, was the force of this rear guard. Familiar with the topography of the country, and taking advantage of it whenever favorable to themselves, these troops were able to conceal their small numbers and to check the Union advance until late in the afternoon. Having thus accomplished their object, which was to gain time for the main body, they then retired toward Crab Orchard. From a few prisoners, taken by the Union troops, they learned that the main body of Gen. Bragg's army and half his wagon train had passed through Stanford on the previous day, and the other half of the wagon train had gone safely through Lancaster, and were retreating on the Richmond and Big Hill road. That night the Union army encamped at Stanford. Early the next morning, the 14th, it was on the march, and soon reached Crab Orchard, a distance of ten miles. As it approached the town, the Confederate rear guard made its appearance drawn up in battle array. It had taken possession of two hills, and was in a good position to make a formidable resistance for a short time. This caused the Federal column to halt. The artillery was then brought up into position, a line of battle was formed, a reconnoissance made, an advance of skirmishers thrown out, and other details performed which caused a delay of several hours. During all this time the army of Gen. Bragg was unmolested and in full retreat. When all the Federal preparations were complete, the Confederate rear guard hastily retired. The Union advance, on the next day, reached Mt. Vernon. On the next day, the 16th, the division of Gens. Van Cleave and Smith were ordered forward; the rest of the advance halted. At this time Gen. McCook's corps and a part of Gen. Gilbert's were at Crab Orchard, and all the cavalry had

been ordered to the rear in consequence of the difficulty of obtaining forage in the mountainous region. On the hills and in the defiles between Mt. Vernon and the State line, ten thousand men would be as effective as forty thousand in resisting an army. The pursuit of the Confederate forces now lost all of its importance.

The result of the invasion of Kentucky was undoubtedly regarded by the Confederate leaders as successful in obtaining supplies, but they were greatly chagrined at the tardiness of the Kentuckians to rally around the Confederate standard. The desertions from their force exceeded the number of recruits obtained. The Confederate forces now retired into east Tennessee, and Gen. Buell fell back to the line between Louisville and Nashville, where he was superseded in the command by Major-Gen. Rosecrans, under the orders of President Lincoln. Col. Morgan, with a small guerilla force, still remained in the State. The invasion of eastern Kentucky, by the Confederate forces, cut off the line of communication between the Federal forces at Cumberland Gap in east Tennessee and the north. It was followed by the evacuation of that strong position by the Union General, G. W. Morgan.

Cumberland Gap is south and a little east of Lexington, Ky., and about one hundred and fifty miles distant. It is a natural gap in a mountain nearly eighty miles in length. There are other places in this long mountain which are called gaps, but this name is given more from the fact that the summit at those places is of more easy access than because of any natural depression of the mountain. At the place called Roger's Gap, next to Cumberland, and eighteen miles west, there is actually no gap; but the road, taking advantage of a succession of ridges on the northern side and running diagonally on the southern side, is rendered passable by man and beast, and may, by great exertions, be passed over by wagons and cannon. The distance from the beginning of the ascent on the one side to the ending of the descent on the other is a little more than five miles. Sixteen miles further west is Big Creek Gap, the crossing at which is a little more difficult.

The mountain on each side of Cumberland Gap is about twelve hundred feet high. In the gap it is only four hundred feet. The road through the notch is a good one. On the southern side the mountain is abrupt in some places and almost perpendicular, and the summit is inaccessible without the greatest danger, except by entering the gap and ascending on either the right or left. The northern side is more irregular, breaking off in a succession of smaller mountains and hills, to the valley lying between the gap and Cumberland Ford. But the main mountain towers far above its neighbors. Two roads from Lexington, Ky., lead to the gap. One passes through Nicholasville, Crab Orchard, and Mt. Vernon, by the way of Wild Cat. The other passes through Rich-

mond, by way of Big Hill. From London, Ky., there is but one road. It is flanked on each side by a succession of hills and mountains, and passes through Barbourville, and crosses the Cumberland Ford. Wagons or cannon could scarcely pass by any other route.

This position was important to the Confederate Government, as by its occupation in force they could hold possession of east Tennessee, and prevent any approach from the north to cut their northern railroad line of connection between Richmond and northern Alabama, Mississippi, Nashville, Memphis, and other towns on the Mississippi. Its occupation was also necessary to sustain their advance into eastern Kentucky. A small Confederate force, therefore, took possession of the gap soon after the commencement of hostilities. On the other hand, its possession was important to the Federal Government, as thereby it prevented the invasion of Kentucky from the southeast. It was also the stronghold of east Tennessee, a section in which there existed among the people a stronger and more invincible attachment to the Union than in any other portion of the seceded States. After the defeat of the Confederate forces in southeastern Kentucky, under Gen. Zollicoffer, a body of Federal troops advanced in the direction of Cumberland Gap. On the 15th of February, they were encamped near Cumberland Ford, about ten miles from the gap, which was then occupied by about two thousand Confederate soldiers. Scouting parties were sent out from the camp near the ford, one of which penetrated the gap and captured a few prisoners. On the 18th of March, another expedition consisting of about 12 companies of infantry and 86 cavalry, started from camp near Barbourville, Ky., and crossing the mountain near Big Creek Gap, after four days reached Powell's Valley, five miles from Jacksborough, where a body of about four hundred Confederate cavalry was surprised and routed, and their camp taken possession of. Another body at Jacksborough, about two hundred in number, was next driven out. After remaining four days, the Federal force retired. On the 21st, a strong expedition moved upon the gap and made an attack, and cannonading ensued without any important result except developing the Confederate strength. The Confederate occupation of the gap continued without any serious interference until Chattanooga was occupied by the forces of Gen. Mitchell, as has been stated. This led to its evacuation about the 10th of June. Previous to that date, Gen. Geo. W. Morgan, with a division of Union troops, advanced from Cumberland Ford, and crossing at Roger's Gap, prepared to cut off the supplies for the small force then at Cumberland Gap. Their stock at the time was small; the Confederate forces under Gen. E. K. Smith had moved south from east Tennessee, and the Union forces at hand being large, and threatening in front and rear, no alternative remained to the

garrison but to surrender or evacuate the position. On the 14th of July, an expedition was sent against a body of Confederate cavalry at Wallace Cross Roads, and after a brief skirmish the latter retired. Again, on the 9th of August, Col. De Courcy was on a foraging expedition with the 16th and 42d Ohio, 14th and 22d Kentucky, when the 14th Kentucky, being advanced a short distance beyond Tazewell, was attacked by the 11th and 42d Tennessee, 30th Alabama, and 21st Georgia, under Col. Rains. A severe conflict ensued, in which the Confederate forces were compelled to retire before the artillery that was brought to the aid of the Federal forces.

On the 17th of August, a small Confederate force approached in front of the position, and attacked a body of Union cavalry some two miles out in the valley, who were compelled to retire with a loss of two or three killed and wounded. Their camp, however, was protected from the approach of the Confederate force by the guns on the mountain. On the same day information was received by Gen. Morgan that a large Confederate force had appeared at Barbourville and London, Ky., and captured his supply trains nearly as far back as Crab Orchard. Its object was to hold the Blue Grass region of Kentucky, and ultimately to force the entire division of Gen. Morgan to surrender or hastily evacuate the position. The comparative success of Gen. Bragg in his movements in Kentucky, cut off all the communications of Gen. Morgan, and by Sept. 11, his corn was all gone and nothing remained for his troops but a scanty supply of beans and rice. The force, however, had not remained inactive during this period; about three hundred prisoners and two hundred horses had been captured. The destitute condition of the force for clothes and food, caused the evacuation of the gap by Gen. Morgan on the 17th of September. On that day the 23d Indiana and the 9th Ohio battery left with all the ammunition. During the succeeding night all the troops left except a squad that remained to finish the work of destruction. The magazine was blown up, and the commissary building burned. Nothing but ammunition and a few of the most useful cooking utensils were brought away. Tents, wagons, gun carriages, arms, and accoutrements were changed to a mass of fragments and ashes. The line of retreat was two hundred and fifty miles with a large Confederate force intervening. But the position was one of the strongest in the country, and Gen. Morgan had represented that his supplies were abundant. By the 4th of October the division reached the Ohio river. It had foraged on the country, but suffered at times for water. During the entire march, a Confederate cavalry force harassed the retreat. During nineteen nights the troops bivouacked without a tent. New roads were made, trees cut out, provisions gathered, a hovering enemy kept at check, and a large

force brought safely through to the borders of Ohio.

This body of troops under Gen. Morgan numbered more than ten thousand men. It brought twenty-eight pieces of artillery, six of which were 20-pounder siege guns, and four hundred wagons. Four heavy siege guns were destroyed before evacuating the gap, and a large number of sick men were left behind.

The march was through a mountainous and unproductive country. A court of inquiry was subsequently ordered to investigate the causes of this evacuation. The position has been subsequently occupied by a small Confederate force.

It has been stated, that on the advance of the Confederate army from Richmond to attack the forces of Gen. Pope, troops were summoned by the general-in-chief from points adjacent to come to his support. Among others a portion of the troops of Gen. Cox in western Virginia were brought on to unite with the army of Virginia. The effect of thus reducing the force in western Virginia was an invasion by a Confederate force under Gen. Loring. He advanced up the Kanawha Valley as far as Charleston, which he occupied for some time. His troops were finally required to reinforce Gen. Lee's army, when he retired. The chief advantage derived from this invasion by the Confederate people was the seizure of the salt works in the Kanawha Valley. Perhaps there was no article of which they were so destitute in comparison to its importance as salt. It was exchanged by the Confederate colonel Echols, who had charge, for forage for his troops. Affairs remained in this situation until the return of Gen. Cox's forces early in November, when the Confederate forces retired.

It has also been stated that, on the invasion of Kentucky by Gen. Bragg, a portion of Gen. Grant's troops were withdrawn from Mississippi and sent to Kentucky and Cincinnati to give confidence to the new levies, and to reinforce Gen. Buell. The consequence of the withdrawal of these troops was to induce the Confederate officers to renew their operations in north Mississippi and western Tennessee. On the departure of Gen. Halleck to take the position of general-in-chief, Gen. Grant was put in command of the department of west Tennessee, including the districts of Cairo and Mississippi, that part of the State of Mississippi occupied by Federal troops, and that part of Alabama which might be occupied by the troops of his particular command, including the forces heretofore known as the army of the Mississippi.

In the department of Gen. Grant it became apparent in August that the Confederate forces south of his position had assumed a threatening attitude upon his line between Corinth in Mississippi, and Tuscumbia in Alabama. On the 10th of September the 2d brigade of Gen. Stanley's division, commanded by Col. Murphy, evacuated Tuscumbia, and fell back thirty

miles upon Iuka. On the next day the Ohio brigade, which had been occupying Iuka, fell back to Corinth, leaving the force with Col. Murphy in its place. Scarcely, however, had it reached Corinth before information was received that a body of Confederate cavalry had dashed into Iuka, and after a slight skirmish put the force of Col. Murphy to flight. A considerable amount of medical and commissary stores was captured, among which were six hundred and eighty barrels of flour that Col. Murphy had neglected to destroy. Col. Murphy was immediately placed under arrest by Gen. Rosecrans, who now commanded the forces previously under Gen. Pope, and the brigade was ordered back to Iuka under Col. Mower. It, however, finally reached the neighborhood of Jacinto, and was there instructed to await further orders. The preparations of the army for an active campaign were now commenced. Transportation and baggage were reduced, and the supply of tents cut down. At this time information was received that the Confederate general Price had not only occupied Iuka in force, but was endeavoring to cross the Tennessee river for the purpose of getting in the rear of Gen. Buell, then falling back toward Nashville. It was also a part of the plan of Gen. Price, by his movement upon Iuka, to draw the Federal forces away from Corinth, and thus render its capture easy by Gen. Van Dorn, who was to attack it during the absence of Gen. Grant's forces. The design was then formed by Gens. Grant and Rosecrans to cut off the retreat of Gen. Price, and force him to surrender. For this purpose eighteen thousand men under Gens. Grant and Ord were to move by way of Burnsville, and attack Gen. Price, while Gen. Rosecrans should move with part of his force by the way of Jacinto, and attack him on the flank; at the same time the remainder of Gen. Rosecrans' force was to move on the Fulton road and cut off Gen. Price's retreat if he should attempt it. With this understanding the army was put in motion on the morning of the 18th of September. The divisions of Gens. Stanley and Hamilton under Gen. Rosecrans, after a fatiguing march in a drenching rain, bivouacked at Jacinto. Early the next morning they were again on the march, and at ten o'clock the advance encountered the Confederate pickets at Barnett's Corners. A sharp skirmish ensued, which resulted in driving them six miles toward Iuka, with a small loss. At this time the entire column had arrived at Barnett's Corners, and awaited, according to the previous understanding, for Gen. Grant to commence the attack, which would be known by the sound of his artillery. After two hours had elapsed a despatch arrived from Gen. Grant, seven miles distant, to the effect that he was waiting for Gen. Rosecrans to open the battle. The column was immediately moved forward within two miles of Iuka, when the Confederate force was discovered posted on a broad ridge commanding the country for some

distance. The Confederates opened fire upon the skirmishers as they advanced in sight, under which Gen. Hamilton's division formed in line. They were also received by a hot fire of artillery and musketry, which was replied to by the 11th Ohio battery, that had now got into position. The engagement soon became general, and continued for two hours, when darkness prevented any further advantage to either side. The contest was exceedingly fierce, and the troops behaved with great bravery. The 11th Missouri and the 5th Iowa stood the severest portion of the contest, and the former lost seventy-six, and the latter one hundred and sixteen in killed and wounded. The 11th Ohio battery was exposed to a severe fire of musketry, and in less than half an hour seventy-two of its men were killed or wounded. The Confederate officers, perceiving that it was poorly supported, ordered a charge to be made on it, by which the six guns were captured, and two of them spiked. It was afterward retaken twice by the 5th Iowa at the point of the bayonet, but finally fell into the possession of the Confederates. The night was spent in taking care of the wounded and burying the dead, while the troops lay on their arms awaiting the dawn of the next day to renew the battle.

Early in the morning, as no movement was perceived on the part of the Confederate force like renewing the contest, Gen. Rosecrans ordered his line of pickets to advance. Not meeting with any opposition the whole force was thrown forward, and within a half mile of the town a flag of truce was seen approaching. It reported that Gen. Price had evacuated the town during the night. Pursuit was immediately made and kept up by three companies of cavalry during the day, skirmishing with the Confederate rear guard, and capturing many prisoners. The loss of Gen. Rosecrans' force was 148 killed, 570 wounded, and 94 missing. The Confederate loss was supposed to be larger in killed and wounded, and about one thousand prisoners were taken by Gen. Rosecrans. At Iuka the six pieces of the 11th Ohio battery were found, having been abandoned, and also a large number of wounded, and commissary stores and camp equipage. Among the killed were the Confederate generals Lytle and Berry. Gen. Whitfield also was mortally wounded. The road by which Gen. Price retreated being unobstructed, he marched that day twenty-seven miles to Bay Spring.

The force of Gen. Grant left Corinth at the same time when Gen. Rosecrans marched, and reached Burnsville, Miss., in the afternoon. There it remained one night and the next day, and then pushed forward until it met the Confederate pickets. Then it retired and awaited the next morning, when a flag of truce was sent to the Confederate camp, which did not return until late in the afternoon. Thus while Gen. Rosecrans engaged the Confederates on the south, Gen. Grant was prevented from engaging them on the west and north.



The effect of this battle was to relieve Gen. Buell from all danger of an attack by Gen. Price on his rear, while moving against Gen. Bragg. On the 22d Gen. Grant's forces returned to Corinth, and Gen. Rosecrans to Jacinto. Gen. Van Dorn through delays had not reached Corinth as soon as had been planned, and Gen. Grant by now abandoning Iuka reached the former place in advance of Gen. Van Dorn. On the 26th Gen. Rosecrans proceeded to Corinth, and took command of that position, Gen. Grant having been ordered to Jackson, and Gen. Ord to Bolivar. Jackson is forty-seven miles, and Bolivar nineteen miles by railroad north of Grand Junction, which is forty-one miles by railroad west of Corinth. By the ordinary routes Jackson is fifty-one miles north, and Bolivar forty miles northwest of Corinth. Meantime, Gen. Price retreating southwesterly from Iuka by Bay Spring, reached Baldwin, Miss., thirty miles. Thence he moved northwest to Dumas, fifteen miles, where he joined Gen. Van Dorn; thence to Pochontas, thirty miles, where he was joined by Gen. Lovell; thence down the Chewalla, and from thence to Corinth by the old State Line road. Gen. Van Dorn took the chief command at Dumas.

Meanwhile Gen. Rosecrans, anticipating that an attack would be made on his position at Corinth, prepared to meet it. The fortifications constructed by Gen. Beauregard in the beginning of the year were on the north and east, and two miles from the centre of Corinth, and required an immense force to occupy them. After Gen. Halleck took possession of the town he constructed a line of intrenchments inside those of Gen. Beauregard. Afterward, upon consultation between Gens. Grant and Rosecrans, it was determined to construct a line inside that of Gen. Halleck. This was done under the direction of Capt. Prim of the U. S. engineers. It consisted of a chain of redoubts, arranged for the concentric fire of heavy batteries. Learning the approach of the Confederate forces, Gen. Rosecrans ordered Gen. Ogleby with his brigade to proceed up the Chewalla road and meet them, with instructions to resist strongly enough to draw them under the defences of Corinth. McArthur next went forward and sent back for assistance. Gen. Davis was then ordered to send a small force, but moved with his whole division. This occupied the 30th of September, and the 1st and 2d of October. On the 8d the Confederate force was greatly increased, and the fighting became severe; Gen. Ogleby was wounded, and Gen. Hackelman killed, and the loss in killed, wounded, and prisoners was considerable, and the Union troops were driven back to their defences.

On the north and east of Corinth, hill and swampy ground alternate, which is on the whole heavily timbered. On the left hand side of the railroad there is occasionally an open field. The Union army faced to the

north. On the front of its right centre there was a heavily thicketed swamp almost impassable for masses of infantry. On the left centre the ground was quite hilly. Where the right wing was posted it was rolling, but fell off in front into heavily timbered ground, such as to be swampy in rainy weather. The Chewalla road enters the town on the left, and the Bolivar road on the right centre. Excepting at this last named point Corinth was approachable in an unbroken line of battle. The new line of fortifications consisted of four revetted redoubts, covering the whole front of the town, and protecting the flanks. The front of the extreme right was strengthened by the old works of Gen. Beauregard. On the left of the extreme right, which was held by Gen. Hamilton's division, a new five-gun battery was constructed on the night of Friday the 8d. This was in direct range of the point where the Bolivar road entered the town. The previously mentioned fort on the extreme right flanked that road. The hills over which the Chewalla road entered the town were commanded by Fort Williams, which mounted twenty-pounder Parrotts. On a high, narrow ridge was located Fort Robinson, which with Fort Williams enfiladed both the Chewalla and Bolivar roads. Another fort on the extreme left protected the left and strengthened the centre. Several forts in the rear were so located as to be of much service during the action. Their guns were reversed, and turned toward the centre.

On the extreme right was stationed the division of Gen. Hamilton. Its right rested near the fort first mentioned and the old works of Gen. Beauregard, and stretched from the south side of the road to Purdy. Its left rested behind Fort Richardson. On the left Gen. Davies' division joined it, and in consecutive order six companies of Illinois sharpshooters and Burke's Missouri sharpshooters; Gen. Stanley's division, consisting of two brigades, and Gen. McKeon's division, with Gen. Arthur's brigade, were on the extreme left. The cavalry, under the command of Col. Misener, was stationed on the wings and in the rear. Suitable forces were held as reserves and to protect the rear. The front line was covered by crests of undulations on the surface. On the night of the 8d, the Confederate line was formed within a thousand yards of the Union position. Before daybreak the Confederates were heard at work planting a battery on a hill in front of and about 200 yards from Fort Robinett, and soon after they opened a furious fire on Corinth. At daylight, the Parrott guns in Fort Williams opened upon this Confederate battery and in a few minutes silenced it. Two of the guns were removed, but the third was taken and drawn within the Federal line. Skirmishing also opened at various points in front, which was constantly increasing to the magnitude of a battle. The Confederate lines, however, were still invisible. About half past nine o'clock dark and threatening masses of Confederate troops were sud-

denly discerned on the east of the railroad moving up the Bolivar road. They assumed a wedge-like form and advanced impetuously. It was now manifest that the Confederate force had been enticed to attack at the very point where the Federal artillery could sweep it with direct, cross, and enfilading fire. These batteries rent hideous gaps in those massive lines, but they were closed at once and inflexibly pressed forward. Suddenly the Confederate force extended to the right and left, and approached covering the whole field. In front of them, however, was a broad turfied glacis sloping upward to a crest, fringed with determined soldiers and covered with frowning batteries. The few obstructions from fallen timber produced no disorder in the approaching lines but what was quickly restored. The entire Federal line next opened fire, but the Confederate forces, as if insensible to fear, steadily pressed forward undismayed. As they approached the crest of the hill in front and to the right of Fort Richardson, the division of Gen. Davis, although not in immediate danger, began to fall back in disorder. Gen. Rosecrans, seeing the disgraceful scene, dashed forward inflamed with indignation and began thrashing the fugitives with the blade of his sabre. His staff, and even his orderlies, followed his example, and the panic was checked and the line restored. Much space was thus lost, and the enemy reached the headquarters of Gen. Rosecrans and took possession. The loss of fort Richardson now appeared certain. The Confederates gained the crest of the hill, swarmed around the little redoubt, and were swept away. Again they came like infuriated tigers, and with a yell made a desperate dash before which the battery, unsupported, gave way. The guns were seized, but before they could be manœuvred, the 56th Illinois, rising from cover in the ravine, fired a deadly volley and with a shout made a sweeping charge, before which the Confederates fled. When the division of Gen. Davis broke, it was necessary for all to fall back, but this charge of the 56th Illinois recovered the ground. The whole line advanced, and the Confederates were broken and fled to the woods, whither they were pursued. The attack on the Federal right was made by Gen. Price. On the left Gen. Van Dorn was expected to make a simultaneous approach and thus carry Corinth by assault. In the extension of the Confederate right, artificial obstructions interfered. Gen. Van Dorn was obliged to move with his left over a rugged ravine through dense thickets and over a heavy abatis up hill. His centre moved down hill under the fire of Fort Williams, the siege guns in the rear of the town, and under heavy musketry. His right was obliged to move round a ridge and advance over almost insurmountable abatis under the direct fire of both Fort Williams and Fort Robinett well supported by experienced troops. Gen. Van Dorn's advance had necessarily been slower than that of Gen.

Price, and the latter was overwhelmed and defeated when the former was ready to commence the attack. His forces advanced steadily, with troops from Mississippi and Texas in front. Huge gaps were made through their ranks by the great guns of the batteries, but they closed and at once moved unflinchingly onward. The slaughter was great, but none wavered. As they reached the ditch a pause, as if for breath, was made. That pause was fatal to them. The two redoubts, Fort Robinett and Fort Williams, were on the same ridge, and the former, which was in front, was commanded by the latter. They were about 150 yards apart. The Ohio brigade, Col. Fuller commanding, was formed behind the ridge on the right of the redoubts. The left of the 63d Ohio rested on Fort Robinett, and its right joined the left of the 27th Ohio; the 39th Ohio was behind the 27th supporting it; the right of the 43d Ohio joined the left of the 63d, forming a right angle with it, and extending to Fort Williams behind the crest of the ridge. The 11th Missouri was formed behind the 63d Ohio, with its left in the angle and the regiment facing obliquely to the right of the 63d. The brigade were required to lie flat on their faces, and reserve their fire until the Confederates were close upon them. At the moment when the Confederate advance paused, as above stated, the 63d Ohio was ordered to fire. An officer has thus described the scene which ensued: "There were only 250 of the 63d in the conflict, but their volley was fearful. It is said 50 Confederates fell at once. Six volleys were fired and the enemy was gone. The 63d again lay down. Directly the supporting Confederate brigade advanced. The 63d was ordered to make a half left wheel to sweep the front of the redoubt, and the manœuvre was handsomely executed. The 11th Missouri moved on the left into line into the vacant space; the 43d moved by the right of companies to the left, and the 27th half-faced to the left. Suddenly the enemy appeared, and a furious storm of lead and grape was launched at them. The 63d fired five or six volleys and the enemy rushed upon them. A terrific hand to hand combat ensued. The rage of the combatants was furious and the uproar hideous. It lasted hardly a minute, but the carnage was dreadful. Bayonets were used, muskets clubbed, and men were felled with brawny fists. Our noble fellows were victors, but at a sickening cost. Of the 250 of the splendid 63d, 125 lay there on the field, wounded, dead, or dying. The last final struggle terminated with a howl of rage and dismay. The foe flung away their arms and fled like frightened stags to the abatis and forests. The batteries were still vomiting destruction. With the enemy plunging in upon him, brave Robinett, with his faithful gunners of the 1st U. S. artillery, double shotted his guns and belched death upon the infuriate host, and now he sent the iron hail after the fugitives with relentless fury. The abatis was full of them,

but they were subdued. Directly they began to wave their handkerchiefs upon sticks in token of submission, shouting to spare them "for God's sake." Over 200 of them were taken within an area of a hundred yards, and more than 200 of them fell in that frightful assault upon Fort Robinett. Fifty-six dead were heaped up together in front of that redoubt, most of whom were of the 2d Texas and 4th Mississippi."

The battle was now over. It had begun in earnest about 9 o'clock, and at half past 11 the Confederate force was falling back. The front was so thoroughly masked that it was late in the afternoon before it could be determined whether a second assault was intended. Pursuit in force could not be attempted before rations and ammunition were provided. It was 3 o'clock on the morning of the next day, Sunday the 5th, before the column moved in light order and swiftly. The vigor and determination with which Gen. Rosecrans would pursue a flying foe may be understood from his views expressed to his officers: "Follow close; force them to pass to the rear; compel them to form often in line of battle and so harass and discourage them; prevent them from communicating from front to rear; give them no time to distribute subsistence; don't let them sleep." Meantime, after the Confederate force had retired, Gen. McPherson arrived with 3 regiments from Jackson, and led the van of the pursuit.

The Confederate force retreated by the route on which they had advanced, which was the Chewahatchie road. It was necessary for them to cross the Tuscumbia river in the neighborhood of Pocaahontas. They sent a body of troops to protect the Hatchie river bridge, which is two miles from the bridge across the Tuscumbia. On the 4th Gen. Ord and Hurlbut, from Gen. Grant's force, moved down and encountered this detachment and defeated it, capturing a large number of prisoners and two batteries of 6 guns. The Federal loss here was 50 killed, 493 wounded, and 17 prisoners. This action compelled the Confederate force to retrace their steps and by making a wide circuit they finally crossed the Hatchie at Crum's Mill, about 6 miles farther up. Gen. Rosecrans, however, continued the pursuit to Ripley, whence he was ordered by Gen. Grant to return. He captured nearly 1,000 prisoners, part of the Confederate ammunition and baggage trains, and 11 guns. The Federal loss at Corinth was stated at 315 killed, 1,312 wounded, and 222 prisoners, taken chiefly on Friday, and two Parrott guns. The additional effects of the battle are thus stated by Gen. Rosecrans in an address to his troops, dated October 25:

I have now received the reports of the various commanders. I have now to tell you that the magnitude of the stake, the battle and the results, become more than ever apparent. Upon the issue of this fight depended the possession of west Tennessee, and perhaps even the fate of operations in Kentucky. The entire available force of the rebels in Mississippi, save a few garrisons and a small reserve, attacked you. They

were commanded by Van Dorn, Price, Villipigue, Rust, Armstrong, Maury, and others in person. They numbered, according to their own authorities, nearly 40,000 men—almost double your own numbers. You fought them into the position we desired on the 3d, punishing them terribly; and on the 4th, in 8 hours after the infantry went into action, they were completely beaten. You killed and buried 1,428 officers and men; some of their most distinguished officers falling—among whom was the gallant Colonel Rogers, of the 2d Texas, who bore their colors at the head of his storming column to the edge of the ditch of "Battery Robinett," where he fell. Their wounded, at the usual rate, must exceed 5,000. You took 2,268 prisoners, among whom are 187 field officers, captains, and subalterns, representing 58 regiments of infantry; 16 regiments cavalry; 13 batteries of artillery; 7 battalions; making 69 regiments, 13 batteries, 7 battalions, besides several companies. You captured 3,300 stands of small arms, 14 stands of colors, 2 pieces of artillery, and a large quantity of equipments. You pursued his retreating columns 40 miles in force with infantry, and 69 miles with cavalry, and were ready to follow him to Mobile, if necessary, had you received orders. I congratulate you on these decisive results; in the name of the Government and the people, I thank you. I beg you to unite with me in giving humble thanks to the Great Master of all for our victories.

After the battle at Corinth and the pursuit of the Confederate force, the troops of Gen. Grant returned to their respective positions. Gen. Rosecrans, on the 25th of October, was ordered from Corinth to Cincinnati to take command of the forces preparing for a new campaign. On the 4th of November the forces of Gen. Grant advanced from Jackson and Bolivar to Lagrange, 8 miles east of Grand Junction on the Cairo and New Orleans railroad. The scattered forces of Gen. Van Dorn and Price had rallied and were within 20 miles of the same place, at Cold Water and Holly Springs, Mississippi. Their numbers had not been increased by reinforcements, but they had been rendered more effective by concentration. The forces of Gen. Grant had been slightly increased by the new levies. His army was required to garrison Columbus, Humboldt, Trenton, Jackson, Bolivar, Corinth, and Grand Junction, and was now designated as the army of west Tennessee. The position of the army was unchanged until near the end of November. It required reinforcements and supplies. Active efforts were made to repair the Memphis railroad in order that supplies might be brought from that point instead of Columbus in Kentucky. The distance to the latter place is 188 miles, and to the former, from Lagrange, 49 miles. On the south a small body of troops was thrown forward a few miles to Davis's Mills, and on the west a heavy force had been stationed at Moscow. On the 28th, however, the advance of Gen. Hamilton's corps began to move in the direction of Holly Springs, which place was reached on the 29th. By the 1st of December, Gen. Grant's forces had arrived and were chiefly encamped at Lumpkin's Mills, south of Holly Springs, and 7 miles north of the Tallahatchie river. The Confederate force had retired to the river. At the same time that the movement was commenced from Davis's Mills, a division of Gen. Curtis's army left Helena,

Ark., for the purpose of making a flank movement on the Confederate force on the Tallahatchie and getting in their rear, and thus cutting off their retreat while the main army advanced upon them. On the river extensive fortifications had been thrown up as if for the purpose of making a determined stand against the prog-

skirmishes with the Federal advance. On the 4th Gen. Grant's headquarters were at Oxford. The main body of the army was at Abbeville. As it advanced, the bridges and culverts of the railroad were repaired, the track restored, and the cars run. At the same time the Confederate force continued to fall back toward Grenada, presenting only a strong rear guard.

Meantime the expedition from Helena above-mentioned, moved on the 27th of November with seven thousand men under Gen. Alvin P. Hovey. On the next day he crossed the Tallahatchie. The passage was disputed by Confederate pickets without loss. On the 30th a second skirmish occurred at the Yacknapatapha, after the crossing of which the Confederate forces retired toward Coffeeville. The next movement of Gen. Hovey was to cut the Mississippi Central railroad and the telegraph line. The railroad line was destroyed for a considerable distance. The Confederate communication on the Mississippi and Tennessee railroad for a short distance was next cut near Panola, by a cavalry force sent out by Gen. Hovey under Col. Washburn. In executing this order, on Dec. 1, Col. Washburn unexpectedly encountered a cavalry force near Oakland, on the Mississippi and Tennessee railroad, and a sharp skirmish ensued. The superiority of the Federal artillery soon put an end to it, and the Confederate forces retired in the direction of Coffeeville, with a loss of five killed, several wounded, and about fifty taken prisoners. The loss of Col. Washburn was fifteen men wounded and fifteen horses killed. The steamboats and small craft on the Tallahatchie river were destroyed, and two locomotives and some cars on the railroad, and the expedition then returned to Helena. The effect of this movement was to cause the Confederate force under Gen. Pemberton to fall back from the Tallahatchie, evacuate Grenada, and retire toward Canton, under the impression that the entire command of Gen. Grant was very strong. The effect of the return of this force to Helena was to restore the confidence of the Confederate general Van Dorn, and an attack upon Gen. Grant's rear, in order to cut off his supplies, was immediately organized, and on the 20th, while Gen. Grant's headquarters were at Oxford, an attack by surprise was made on the garrison at Holly Springs, thirty miles north, by a considerable force of cavalry, to whom the place was surrendered. The prisoners were paroled, the immense stores collected there for Gen. Grant's army were destroyed, also a large quantity of cotton which had been purchased of the people in the vicinity. On the same day a similar attack was made at Davis's Mills, a little farther north, which was bravely repulsed. Near Jackson, in Tennessee, previously the headquarters of Gen. Grant, an attack was made on the 19th by a body of cavalry with artillery, under Col. Forrest. It was first made upon a train loaded with wood. The telegraph wire was also cut,



ress of the Federal army. These, however, were abandoned on Dec. 1 by Gen. Van Dorn, and his forces retired farther south. It was supposed that information of the flank movement from Helena led to the evacuation of his strong position on the Tallahatchie. On the 2d his rear guard passed through Abbeville, and on the 8d through Oxford, with some sharp

and the road destroyed. On the next day Humboldt was captured, and an attack was made on Trenton, which was soon surrendered by Col. Fry in command. The railroad depot was burned with all the stores and cotton in it. Other stations on the road, as Dyer, Rutherford, and Keaton, were taken on the same day. The purpose was to destroy every bridge on the railroad from Columbus to Corinth and Grand Junction, and thus cut off the route for supplies to Gen. Grant's army. The consequence of destroying his depot of supplies, and disturbing his line of communication, was to make Gen. Grant fall back upon Holly Springs. Subsequently Col. Forrest's force was entirely routed by Col. Sweeney.

Meanwhile troops had been collected at Cairo and Memphis, for an expedition against Vicksburg. This had been done within the department of Gen. Grant, and the commander of the expedition, Gen. Sherman, was stationed at Memphis in the same department, and under the command of Gen. Grant. It was an object of Gen. Grant's movements into Mississippi, just related, to reach Jackson in the rear of Vicksburg, and thus cooperate with Gen. Sherman. In this design he was unsuccessful, and obliged to fall back in consequence of the attacks on his line of communication. After falling back upon Holly Springs, a division of his troops was sent to join Gen. Sherman. The future proceedings of Gen. Grant and of this Expedition properly belong to the record of 1863.

The second campaign in Kentucky and Tennessee during the year was virtually ended. The forces of Gen. Grant were reduced by a detachment of ten thousand men to aid Gen. Sherman in the capture of Vicksburg, which was a part of the new campaign.

Meanwhile the calls of the President for six hundred thousand additional troops were producing their effect. Vast forces were gathering, and new campaigns were about to commence. The great march of the Northwest sweeping everything before it to the Gulf of Mexico, was now to be made. The Government had found that the Western people would bear no longer with its futile efforts to open the Mississippi and to seize the Southern valley. "What we need," said President Lincoln, "is a military success;" money and men had been promptly furnished to the full extent of the request.

This new campaign contemplated the advance of a powerful army under Gen. Rosecrans through Tennessee into Alabama; the movement of a military and naval expedition from Cairo upon Vicksburg; the cooperation of an expedition under Gen. Banks from New Orleans, and thence into Texas; and an advance from Missouri upon Arkansas; and also from Kansas upon the Indian country and northern Texas. Thus the Federal Government would not only open the Mississippi river, but occupy all the Southwestern States, and re-

duce the Confederate forces to the limits of the Atlantic States.

On the 25th of October, Gen. Rosecrans was ordered to Cincinnati to take command of the army of the Ohio, as already stated. This command consisted of what remained of the splendid army of Gen. Buell, reinforced by new but raw levies, until it became the second army in size of the United States. The preparation for his campaign was no ordinary effort.

The new troops were to be drilled, disciplined, and made reliable; equipments, arms, horses, and stores of every kind were needed.

The country in which he proposed to march had just been swept of its forage by two armies—that of Gen. Buell, and that of Gen. Bragg. His supplies must come from the States of the Northwest. Only two routes existed for their conveyance: the Cumberland river, which was at too low a stage of water for successful navigation, and the Louisville and Nashville railroad, on which the bridges had been burned, and the tunnel at Gallatin destroyed. The work of preparation and organization was vigorously begun, and his army soon began to move southward. On the 1st of November Gen. Rosecrans moved to Bowling Green, and on the 5th three divisions of Gen. McCook's corps moved farther on their way to Tennessee.

The commanders of the corps of the whole army were Gens. Thomas, McCook, Rousseau, and Crittenden. On the 7th the corps of Gen. McCook passed through Nashville.

The Louisville and Nashville railroad was completed on the 8th to Mitchellville on the northern line of Tennessee. On the 10th, Gen. Rosecrans arrived at Nashville, and from that time to the close of the year he was constantly engaged in concentrating, reorganizing, reëquipping, and disciplining his army, accumulating supplies by the railroad, of which there was only a single track, and preparing for a forward movement. As early as the 25th of November, the Confederate army manifested a purpose to contest the occupation of middle Tennessee. The railroad bridge at Bridgeport was repaired and troops hurried to Murfreesborough. Gen. Joseph Johnston had been placed in command of this Confederate department, although unable to engage in active field operations. The Confederate forces were stationed at Laverne, Murfreesborough, McMinnville, &c. Their numbers, under Gen. Bragg, were estimated at forty-five thousand effective men. He had been led to believe by the spies of Gen. Rosecrans that the latter intended to go into winter quarters at Nashville, and had despatched one body of cavalry under Gen. Forrest to cut off Gen. Grant's communication, and another body under Col. Morgan to cut the communication of Gen. Rosecrans in Kentucky, and also a body of infantry to the Confederate army of Mississippi. This appeared to be the opportunity for Gen. Rosecrans to strike an effective blow. At this time, the Federal army

occupied a line of about ten miles on the southeasterly front of Nashville facing south, the right resting on the right of the Franklin turnpike, the centre extending out to Breakville on the Nolinsville turnpike, and the left covered by Mill Creek, some six or eight miles from Nashville, with outposts describing an irregular semicircle, covering a distance of nine miles from the city. To this front the Confederate army presented its force with outposts about two miles distant. Gen. E. Kirby Smith's corps, with part of Col. Morgan's cavalry, occupied the Confederate right; the corps of Gen. Polk, with Col. Wheeler's cavalry brigade, occupied the centre at Lavergne; Gen. Hardee's corps at Triune and Nolinsville, with Col. Wharton's cavalry in front, occupied the left. On the night of the 25th, Christmas, the determination for an advance the next day was made. The respective columns were so disposed as to move down Wilson's, the Nolinsville, Murfreesborough, and Jefferson turnpikes. The general plan was to move a brigade down Wilson's turnpike to protect the right, while Gen. Negley should endeavor to turn the Confederate left and get into its rear; Gen. McCook's corps was to press directly upon Gen. Hardee at Nolinsville and Triune, while Gen. Crittenden pushed down the Murfreesborough and Jefferson turnpikes. At dawn on the 26th, the troops broke up camp with wild shouts and poured along the highways. Gen. McCook's corps marched steadily down the road with skirmishers widely spread out. The Confederates resisted sharply, but were steadily driven, the Federal loss being small. Gen. Crittenden advanced to Lavergne without opposition. The Confederates retired rapidly before his skirmishers. On the next day, the 27th, the Confederate force continued to retire as the Federals advanced with sharp skirmishing. At four o'clock P. M., the Confederate right had been driven over the bridge across Stewart's Creek, on the Jefferson turnpike, which they were prevented from destroying. They were also driven over the bridge across the same creek on the Murfreesborough turnpike so rapidly as to be unable to destroy it. Both structures came into the possession of the Federal forces, all the columns of which had now closed up. It was now apparent from the course of the Confederate retreat that their purpose was to concentrate near Stone Creek or river. On Sunday the 28th, Gen. Thomas advanced his camp across Stewart's Creek, and joined the left. Next day, Gen. McCook moved within seven miles of Murfreesborough, and Gen. Crittenden moved within three miles, Gen. Negley advanced to the centre, and Gen. Rousseau's division was placed in reserve, on the right of Gen. Crittenden. On the 30th, Gen. McCook advanced through thickets, stubbornly resisted by the Confederates, and pressed Gen. Hardee's corps in his front in line of battle. The front of this Confederate corps crossed the Federal right obliquely, in a position which, if extend-

ed, would flank it. The centre, under Gen. Negley, was slightly advanced into a cedar wood, and was engaged in reconnoitring under sharp resistance, and in cutting roads through the dense forest to open communication with the right. The left was in a line corresponding with the course of Stone river. The right division of Gen. McCook now faced to the southeast, and two brigades were thrown out on the extreme right, somewhat in reserve. The Confederate force was concentrated within two miles of Murfreesborough, with its right resting on the Lebanon turnpike, thence extending west across Lytle's Creek and the Nashville turnpike, and under the command of Gen. Leonidas Polk. It consisted of three divisions under Gens. Cheatham, Breckinridge, and Buckner. The Confederate centre was composed of three divisions of Gen. E. Kirby Smith; the left was under the command of Gen. Hardee, and rested on the Franklin and Murfreesborough road. This position of the Confederate army gave to it the advantage of strong natural fortifications, with their centre effectually masked by almost impenetrable cedar forests. Constant skirmishing was going on between both forces, and it was manifest that another day would witness the impending battle. At this time assaults were made by cavalry on the Federal rear, and several trains were captured. During the night it was evident that the Confederate forces were massing on the right of Gen. Rosecrans, and his plan was formed to give ground a little, if necessary, on that wing, and to advance the left at the same time into Murfreesborough. The execution of this purpose was prevented by the great force of the Confederate attack on the right.

Early on the morning of the 31st, the attack was made along the entire line of the Federal right under Gen. McCook. The weather was foggy, and the appearance of the Confederate force was sudden. No preparations up to this time for an advance or an assault had been made. An attack very early in the morning had been anticipated; but as it did not come, a degree of carelessness and indifference had taken possession of both officers and men, and all precautions were in a degree abandoned. The opposing lines of the two hostile wings had formed on the opposite sides of a valley which narrowed toward the Federal left. Gen. McCook's corps consisted of three divisions which formed this line. On the left was the division of Gen. Sheridan, in the centre that of Gen. Davis, and on the right that of Gen. Johnson. The attack was made along the entire front at once by the Confederate force, rapidly advancing in double columns. Before the divisions of Gens. Johnson and Davis could form, the Confederate batteries opened upon them, and their infantry soon after became engaged at short range, rapidly advancing and preparing to charge bayonets. Two batteries of Gen. Johnson's division were taken before a gun was fired; and the irregular fire of

the others, many of which had no horses near at hand, and the desultory fire of the incomplete line did not cause the Confederate line to waver, much less repulse it. One brigade of Gen. Johnson's was broken and fled to the rear, leaving the artillery they should have supported, and the men were shot down at the guns. The rest of the division fell back, and with them a few of the guns. The line of Gen. Davis's division, which was attacked at the same time, was also imperfectly formed. In vain it attempted to hold its position. Like that of Gen. Johnson, it was crushed and broken, and three entire batteries lost. The division of Gen. Sheridan, when first assailed, withstood the shock, and forced back the Confederate line; but when the division of Gen. Davis was driven back it stoutly resisted, and endeavored to hold the position until the others could be rallied in the rear, and advanced to its support. The effort, however, was unsuccessful, and like the others, his division retreated. The divisions of Gens. Johnson and Davis had in the mean time formed in the rear, and endeavored to stay the Confederate progress. They were unsuccessful, but maintained their line and fell back in good order, and again formed at the first good position. In like manner Gen. Sheridan proceeded. No guns were captured after the first assault, and the mass of prisoners was taken during this retreat. The object of Gen. Bragg was to turn the right flank, but this failed. Gen. Rosecrans, on the other hand, prepared to stop the progress of the Confederates on his right, without exposing his centre and left to immediate danger. His left wing could not be advanced to Murfreesborough, because his right was gone. He, therefore, massed his artillery upon his centre, at the probable point of assault. These movements were concealed by forests, and were unperceived by the enemy. Gen. Negley now ordered forward the advance of the centre, consisting of two small brigades to protect the retreating forces of Gen. McCook. These were supported by the division of Gen. Rousseau, and served to check the Confederate force in its pursuit of the right wing. As the enemy approached these brigades, they retired slowly. The former, unsuspecting it to be a decoy, rushed forward, and were received with such a cross-fire of double shotted canister from two batteries and a volley from a brigade, as caused their line to waver for a moment. It dashed forward again. In the mean time Gen. Rousseau had come up on the right of Gen. Negley, and his regular troops on his left advanced at the moment when the right of the Confederate left wing dashed forward. The combined fire of Gen. Negley's force and of the regular troops drove the Confederate main force back with terrible loss, and a large number of Confederate prisoners were taken. The struggle was maintained a few moments, when the Federal force under orders fell back, and the Confederate line, flushed with success, and

consisting of their centre and right of left wing, rushed in overwhelming mass upon the batteries which had been so placed as to rake them in almost every direction. A horrible slaughter ensued. The Confederate line wavered, fell back, and attempted to rally. On another discharge, they fled from the fire which they could not face. Meanwhile Gen. McCook had got into line on the right of Gen. Rousseau, and received reinforcements of artillery, and was ready for another attack. The Confederate force had now fallen back, and a suspension of fire took place along the entire line. It was midday. The Federal line had been driven back between two and three miles, thirty pieces of artillery had been lost, and the dead and wounded with many prisoners were in Confederate hands. The spirit of the troops was still resolute.

These movements had somewhat changed the position of the Federal line. The left and centre recovered their position at right angles to the Murfreesborough road and across it. They extended from the river to the distance of a mile west of it. The right wing had fallen back until it was nearly parallel to this road, and extending from Stewart's Creek to the right of Gen. Rousseau. The Confederate left was opposite the Federal right and a few hundred yards from it. In this position both of Gen. Rosecrans's flanks were protected by streams with good bridges and fords in his rear.

About three o'clock, the battle opened again by a Confederate attack upon the Federal centre and left. Although this was made by large masses, yet such was the favorable position occupied by the Federal line on a crest or ridge of ground, and such was the strength of its batteries that no advantage was gained by the Confederates. The slaughter on both sides was great and the contest very determined. It continued until five o'clock when the exhausted armies suspended operations for the night. This was so clear and beautiful that some batteries continued their fire. The result of the day was that the Federal right had been driven in almost upon the left, and a change of front had been made under fire, leaving in possession of the Confederate troops that part of the field. They also held the ground occupied in the morning by the Federal pickets on the left, which wing had receded to draw the Confederate troops on. During this time the communication to Nashville had often been cut off, and a strong force of Confederate cavalry had made a dash in the Federal rear within a mile of the front, and captured a considerable amount of hospital stores. The ammunition train of the right wing was twice captured and twice retaken. The Federal loss on that day was estimated at three thousand killed and wounded, twenty-five pieces of artillery, and a large number of prisoners. The Confederate loss in killed and wounded was not less.

On Thursday the 1st of January, 1863, the line of Gen. Rosecrans was restored to its

original position by the success of Gen. McCook's efforts to recover and hold it, on the third attempt. The division on the extreme left was also moved across Stone river. The position on the right wing was entrenched and the communications in the rear completed. On the morning of the 2d, sharp demonstrations were made along the whole Federal line by the Confederate army, but nothing serious was attempted until three o'clock in the afternoon. At that time the Confederate force burst in mass upon the division across Stone river, as if having discovered the intention of Gen. Rosecrans to advance it in their rear. This attacking force consisted of their entire right wing. The three brigades of the Federal division under Col. Beatty were prepared for the attack and stood their ground manfully, but the overwhelming force finally drove them back across the creek. Gen. Negley's division, which had been formed in reserve as if for this occasion, now advanced, supported by the division of Gen. Davis and the pioneer battalion of Morton. The most bitter conflict of the battle now ensued. Both sides massed their batteries and used them with desperate vindictiveness. The Confederate line wavered and fell back. Gen. Davis was ordered to cross the stream, and Col. Sirwell of the 78th Pennsylvania, placing his hat on the point of his sword, led the way with a shout. Col. Beatty's division followed. An overwhelming and irresistible charge was made on the Confederate line, and it broke and fled. A battery was captured, and a stand of colors. The entire division of Gen. Negley followed up rapidly, and Gen. Rosecrans's whole line immediately advanced. The Confederate right wing was now broken, and the Federal force was gaining the Confederate flank, when resistance on its part became vain and the entire force receded with the loss of many prisoners. The next morning found the Federal line entrenched in its advanced position, but a storm was raging. Quiet prevailed through the day, excepting one or two sharp conflicts resulting in the capture of a Confederate breastwork. On the next morning the Confederate army had retired from Murfreesborough, which was subsequently occupied by Gen. Rosecrans. Two divisions were soon sent forward in pursuit of the forces of Gen. Bragg, who fell back to Tallahoma. The Federal loss was 8,485 killed and wounded, and 3,600 missing. The Confederate loss is not known.

The original plan of Gen. Rosecrans to turn the right of the Confederate army and cut off its retreat, was entirely defeated by the failure of the right wing to maintain itself. The subsequent movements of the army of the Cumberland, properly belong to the history of the year 1863.

The conclusion of the campaign in Virginia remains to be described. Immediately after the battle of Antietam, the Confederate army retired across the Potomac and occupied strong positions on its right bank. All hopes

that the State of Maryland would unite her destinies with the Southern Confederacy were now banished. The invasion had been made by crossing the Potomac within a limit of twelve miles, which is about a mile above the Point of Rocks and five miles below the Monocacy aqueduct on the Chesapeake and Ohio canal. The army then marched through fields, woods, and roads for Frederick. The line of the Chesapeake and Ohio canal for twelve miles presented a scene of desolation. It was tapped at five places. Several floodgates were cut to pieces, and from heights above large boulders of rock were dislodged and thrown into the canal. An unsuccessful attempt was made to blow up the aqueduct at Monocacy. The telegraph lines and the track of the Baltimore and Ohio railroad were much injured. The bridge at Monocacy and portions of the abutments were destroyed. Private property did not escape. Fences were torn down and fields laid desolate.

The influence produced by the activity of the militia of Pennsylvania in responding to the call of the governor to aid in the defence of that State, is acknowledged by Gen. McClellan in the following letter:

HEADQUARTERS ARMY OF THE POTOMAC, }  
SHARPSBURG, September 27, 1862. }

GOVERNOR: I beg to avail myself of almost the first moment of leisure I have had since the recent battles to tender to you my thanks for your wise and energetic action in calling out the militia of Pennsylvania for its defence, when threatened by a numerous and victorious army of the enemy. Fortunately circumstances rendered it impossible for the enemy to set foot upon the soil of Pennsylvania, but the moral support rendered to my army by your action was none the less mighty.

In the name of my army and for myself I again tender to you our acknowledgments for your patriotic course. The manner in which the people of Pennsylvania responded to your call and hastened to the defence of their frontier no doubt exercised a great influence upon the enemy.

I am, very respectfully and sincerely, yours,  
GEO. B. MCCLELLAN,  
Maj.-Gen. U. S. Army.

His excellency A. G. CURTIS,  
Governor of Pennsylvania.

The army of Gen. McClellan remained on the north bank of the Potomac in the vicinity of Sharpsburg and Harper's Ferry. On the 1st of October it was visited by President Lincoln, who was cordially received and tarried until the 4th. On the 7th Gen. McClellan issued the following order relative to the Proclamation threatening emancipation of the Southern slaves:

HEADQUARTERS ARMY OF THE POTOMAC, October 7, 1862.

General Order, 163.—The attention of the officers and soldiers of the Army of the Potomac is called to General Order, No. 139, War Department, September 24, 1862, publishing to the army the President's proclamation of September 22.

A proclamation of such grave moment to the nation, officially communicated to the army, affords to the General commanding an opportunity of defining specifically to the officers and soldiers under his command the relation borne by all persons in the military service



of the United States toward the civil authorities of the Government.

The Constitution confides to the civil authorities—legislative, judicial, and executive—the power and duty of making, expounding, and executing the Federal laws. Armed forces are raised and supported simply to sustain the civil authorities, and are to be held in strict subordination thereto in all respects. The fundamental law of our political system is essential to the security of our republican institutions, and should be thoroughly understood and observed by every soldier.

The principle upon which and the objects for which armies shall be employed in suppressing rebellion must be determined and declared by the authorities, and the Chief Executive, who is charged with the administration of the national affairs, is the proper and only source through which the views and orders of the Government can be made known to the armies of the nation.

Discussion by officers and soldiers concerning public measures determined upon and declared by the Government, when carried beyond the ordinary, temperate, and respectful expression of opinion, tend greatly to impair and destroy the discipline and efficiency of the troops, by substituting the spirit of political faction for the firm, steady, and earnest support of the authority of the Government, which is the highest duty of the American soldier. The remedy for political errors, if any are committed, is to be found only in the action of the people at the polls.

In thus calling the attention of this army to the true relation between the soldiers and the Government, the General commanding merely adverts to an evil against which it has been thought advisable during our whole history to guard the armies of the Republic, and in so doing he will not be considered, by any right-minded person, as casting any reflection upon that loyalty and good conduct which have been so fully illustrated upon so many battle-fields.

In carrying out all measures of public policy this army will, of course, be guided by the same rules of mercy and Christianity that have ever controlled its conduct toward the defenceless.

By command of Maj.-Gen. McCLELLAN.

JAS. A. HARDIE, Lieut.-Col.,  
Aide-de-Camp and Act'g Ass't Adj.-General.

On Monday night, Oct. 10, a body of Confederate cavalry of about twenty-five hundred, under Gen. Stuart, suddenly appeared at Chambersburg, Penn., and occupied the place. The Government storehouses and machine shops were burned by them; also the Cumberland Valley railroad depot. On the next day Gen. Stuart marched to Emmetsburg, thence to Woodsborough, New Market, and Monrovia, which place he reached early on Sunday morning. Thus far his force had gathered about one thousand horses. He next pushed for the Potomac, at Noland's Ford, at the mouth of the Monocacy; but finding a Federal force there, he divided his troops and crossed at different places, chiefly at Conrad's Ferry, and six miles below the Monocacy. The entire distance of his march north of the Potomac, was a little over one hundred miles. A large number of Federal troops were put in motion to effect his capture, but without success. Reconnoissances made on the 16th and 17th discovered the Confederate army occupying a position extending from Bunker Hill to the Shenandoah river.

It had been expected that Gen. McClellan would take the forces of Gen. Pope's shattered army and march into Maryland and conquer the victorious Confederate force and

pursue them even to Richmond. The inactivity of his army after the battle of Antietam became a subject of complaint. It was overlooked that the low water in the Potomac required time to line its north shore with troops to prevent another invasion of Maryland. It was overlooked that most of his troops had been in active service in the field during the previous six months, and might require most important supplies. On the 6th of October the following despatch was sent by the general-in-chief, Gen. Halleck, to Gen. McClellan:

WASHINGTON, D. C., Oct. 6, 1862.

Maj.-Gen. McClellan:

I am instructed to telegraph to you as follows: The President directs that you cross the Potomac and give battle to the enemy or drive him south. Your army must move now while the roads are good. If you cross the river between the enemy and Washington, and cover the latter by your line of operation, you can be reinforced with 30,000 men. If you move up the valley of the Shenandoah, not more than 12,000 or 15,000 can be sent to you. The President advises the interior line between Washington and the enemy, but does not order it. He is very desirous that your army move as soon as possible. You will immediately report what line you adopt and when you intend to cross the river. Also, to what point the reinforcements are to be sent. It is necessary that the plan of your operations be positively determined on before orders are given for building bridges and repairing railroads. I am directed to add that the Secretary of War and the General-in-Chief fully concur with the President in these instructions.

H. W. HALLECK, Gen.-in-Chief.

According to the report of Gen. Halleck, Gen. McClellan disapproved of the plan of crossing the Potomac south of the Blue Ridge, and said that he would cross at Harper's Ferry and advance on Winchester. The advance, however, did not take place until the 26th of October. It became the subject of speculation on the part of the public as to the real nature of the causes of delay. Subsequently, upon the removal of Gen. McClellan from the command of the army, on the 7th of November, the following letter was published:

HEADQUARTERS OF THE ARMY,  
WASHINGTON, Oct. 28, 1862. }

Hon. E. M. Stanton, Secretary of War:

SIR: In reply to the general interrogatories contained in your letter of yesterday, I have to report:

1st. That requisitions for supplies to the army under Gen. McClellan are made by his staff officers on the chiefs of bureaus here; that is, for quartermasters' supplies, by his chief quartermaster on the Quartermaster-General; for commissary supplies, by his chief commissary on the Commissary-General, &c. No such requisitions have been, to my knowledge, made upon the Secretary of War, and none upon the General-in-Chief.

2d. On several occasions Gen. McClellan has telegraphed to me that his army was deficient in certain supplies. All these telegrams were immediately referred to the heads of bureaus, with orders to report. It was ascertained that, in every instance, the requisitions had been immediately filled, except one, where the Quartermaster-General had been obliged to send from Philadelphia certain articles of clothing, tents, &c., not having a full supply here. There has not been, so far as I could ascertain, any neglect or delay, in any department or bureau, in issuing all supplies asked for by Gen. McClellan, or by the officers of his staff. Delays have occasionally occurred in forwarding supplies

by rail, on account of the crowded condition of the depots, or of a want of cars; but whenever notified of this, agents have been sent out to remove the difficulty. Under the excellent superintendence of Gen. Haup, I think these delays have been less frequent and of shorter duration than is usual with freight trains. An army of the size of that under Gen. McClellan will frequently be for some days without the supplies asked for, on account of neglect in making timely requisitions and unavoidable delays in forwarding them and in distributing them to the different brigades and regiments. From all the information I can obtain, I am of opinion that the requisitions from that army have been filled more promptly, and that the men, as a general rule, have been better supplied than our armies operating in the West. The latter have operated at much greater distances from the sources of supply, and have had far less facilities for transportation. In fine, I believe that no armies in the world, while in campaign, have been more promptly or better supplied than ours.

3d. Soon after the battle of Antietam Gen. McClellan was urged to give me information of his intended movements, in order that, if he moved between the enemy and Washington, reinforcements could be sent from this place. On the first of October, finding that he proposed to operate from Harper's Ferry, I urged him to cross the river at once and give battle to the enemy, pointing out to him the disadvantages of delaying till the autumn rains had swollen the Potomac and impaired the roads. On the 6th of October he was peremptorily ordered to "cross the Potomac and give battle to the enemy or drive him south. Your army must move now, while the roads are good." It will be observed that three weeks have elapsed since this order was given.

4th. In my opinion there has been no such want of supplies in the army under Gen. McClellan as to prevent his compliance with the orders to advance against the enemy. Had he moved to the south side of the Potomac he could have received his supplies almost as readily as by remaining inactive on the north side.

5th. On the 7th of October, in a telegram in regard to his intended movements, Gen. McClellan stated that it would require at least three days to supply the first, fifth, and sixth corps; that they needed shoes and other indispensable articles of clothing, as well as shelter tents. No complaint was made that any requisitions had not been filled, and it was inferred from his language that he was only waiting for the distribution of his supplies.

On the 11th he telegraphed that a portion of his supplies sent by rail had been delayed. As already stated, agents were immediately sent from here to investigate this complaint, and they reported that everything had gone forward. On the same date (the 11th) he spoke of many of his horses being broken down by fatigue. On the 12th he complained that the rate of supply was only "one hundred and fifty horses per week for the entire army there and in front of Washington."

I immediately directed the Quartermaster-General to inquire into this matter and report why a larger supply was not furnished. Gen. Meigs reported on the 14th that the average issue of horses to Gen. McClellan's army in the field and in front of Washington for the previous six weeks had been 1,459 per week, or 8,754 in all. In addition, that large numbers of mules had been supplied, and that the number of animals with Gen. McClellan's army on the upper Potomac was then thirty-one thousand. He also reported that he was then sending to that army all the horses he could procure.

On the 18th Gen. McClellan stated, in regard to Gen. Meigs's report that he had filled every requisition for shoes and clothing: "Gen. Meigs may have ordered these articles to be forwarded, but they have not reached our depot, and, unless greater effort to insure prompt transmission is made by the department of which Gen. Meigs is the head, they might as well remain in New York or Philadelphia, so far as this army is concerned." I immediately called Gen. Meigs's attention to this apparent neglect of his department. On the 25th he reported, as the result of his investigation, that 48,000 pairs of boots and shoes had been received by the quar-

termaster of Gen. McClellan's army at Harper's Ferry, Frederick, and Hagerstown; that 20,000 pairs were at Harper's Ferry depot on the 21st; that 10,000 more were on their way, and 15,000 more ordered. Col. Ingals, aide-de-camp and chief quartermaster to Gen. McClellan, telegraphed, on the 25th: "The suffering for want of clothing is exaggerated, I think, and certainly might have been avoided by timely requisitions of regimental and brigade commanders." On the 24th he telegraphed to the Quartermaster-General that the clothing was not detained in cars at the depots: "Such complaints are groundless. The fact is, the clothing arrives and is issued, but more is still wanted. I have ordered more than would seem necessary from any data furnished me, and I beg to remind you that you have always very promptly met all my requisitions, so far as clothing is concerned. Our department is not at fault. It provides as soon as due notice is given. I foresee no time when an army of over 100,000 men will not call for clothing and other articles."

In regard to Gen. McClellan's means of promptly communicating the wants of his army to me or to the proper bureaus of the War Department, I report that, in addition to the ordinary mails, he has been in hourly communication with Washington by telegraph.

It is due to Gen. Meigs that I should submit herewith a copy of a telegram received by him from Gen. McClellan.

Very respectfully, your obedient servant,  
H. W. HALLECK, Gen.-in-Chief.

UNITED STATES MILITARY TELEGRAPH.

Received, Oct. 22, 1862—9 40 P. M.

From McClellan's Headquarters.

To BRIG.-GEN. MEIGS: Your despatch of this date is received. I have never intended, in any letter or despatch, to make any accusation against yourself or your department for not furnishing or forwarding clothing as rapidly as it was possible for you to do. I believe that everything has been done that could be done in this respect. The idea that I have tried to convey was, that certain portions of the command were without clothing, and the army could not move until it was supplied.

G. B. McCLELLAN, Maj.-Gen.

Nothing has been made public on the part of Gen. McClellan alluding to or explaining the causes of the delay of the movements of the army. Strict justice requires that, in estimating the importance of the preceding letters, the testimony of Gen. Burnside on a subsequent page should be considered. It was generally understood that Gen. McClellan's movement was delayed by the want of clothing and other supplies, and especially on account of his deficiency in cavalry and artillery horses. The purchase and forwarding of these was going on even up to the day of his crossing the Potomac. One army corps did not receive its clothing until it had commenced its march in Virginia. It was stated by several commanders that they made every effort to get the clothing for their troops, repeatedly sent teams to the railroad depots for it, and until a short time previous to the marching of the army they were invariably told that the clothing had not arrived.

Early on the 26th of October a cavalry force, under Col. Pleasanton, crossed the Potomac on the new pontoon bridge at Berlin, and moved on in the direction of Purcellville. Soon after the corps of Gen. Burnside began to cross in light marching order, followed by an immense train of wagons, and took a position near Lovettsville. On the next day a heavy reinforcement joined him. About the same

time the Confederate force prepared to abandon the line of the Potomac and to fall back. The crossing of the Federal troops was now constant, until the entire army was south of the river. On the 30th of October Gen. Sedgwick advanced from Boliver Heights, and crossed the Shenandoah in the direction of Shannondale, and Gen. Hancock pushed forward, pressing on the Confederate lines in front of Charlestown. Gen. Burnside moved along the eastern base of the Blue Ridge, followed by the corps of Gen. Porter.

The situation of the respective forces at this time was as follows: The Federal army reënforced by the divisions of Gens. Sigel and Sickles, who had advanced from Washington, occupied all the region east of the Blue Ridge, with the right resting on Harper's Ferry, and the left extending nearly to Paris, on the road from Aldie to Winchester. The centre was at Snickersville; with Snicker's Gap in its possession. The Confederate line was on the south side of the Blue Ridge, with the Shenandoah river immediately in its front, extending from Front Royal down to Charlestown, with the great body of their troops massed between Berryville and Winchester. On the 4th Ashby's Gap was occupied without opposition by the Federal troops. The cavalry corps, under Col. Pleasanton, pushed on from Piedmont, and occupied Marguette, holding the approaches to Manassas and Chester Gap, on the left side of the Blue Ridge. The condition and spirit of the army at this time were unequalled by that of any force before organized. On the 6th Gen. McClellan's headquarters were at Rectortown near Front Royal. The army was steadily advancing and the Confederate force falling back, with some skirmishing. Warrenton was occupied by the Federal troops on the same day. On the 7th a severe snow storm commenced, and continued throughout the day. On the 8th the bridge at Rappahannock Station was taken and held by Gen. Bayard. On the night of the 7th, near midnight, Gen. Buckingham arrived, from Washington, at Gen. McClellan's tent, and delivered to him an order from President Lincoln, to surrender the command of the army to Gen. Burnside, and to report himself immediately at Trenton, the capital of the State of New Jersey. This order was entirely unexpected by Gen. McClellan, and probably by every officer of the army. The only reasons for it which have officially appeared, will be found in the above letter of Gen. Halleck, dated October 28, which was given to the public a few days after this removal.

Gen. McClellan immediately wrote the following address to his troops preparatory to his departure:

HEADQUARTERS OF THE ARMY OF THE POTOMAC, }  
CAMP NEAR RECTORTOWN, VA., November 7. }

*Officers and Soldiers of the Army of the Potomac:*

An order of the President devolves upon Maj.-Gen. Burnside the command of this army. In parting from you I cannot express the love and gratitude I bear to you. As an army you have grown up in my care. In

you I have never found doubt or coldness. The battles you have fought under my command will probably live in our Nation's history. The glory you have achieved over mutual perils and fatigues; the graves of our comrades fallen in battle and by disease; the broken forms of those whom wounds and sickness have disabled; the strongest associations which can exist among men unite us by an indissoluble tie. We shall ever be comrades in supporting the Constitution of our country and the Nationality of its people.

(Signed)

GEO. B. McCLELLAN.

Major-General U. S. A.

The next day was devoted by Gen. McClellan to the transfer of his command to Gen. Burnside. The most cordial feelings existed between the two officers, the latter of whom accepted a promotion which he had before twice declined, only upon the peremptory order of the War Department. On Sunday evening his officers assembled at his tent, for a final parting of commander and officers. It was such a scene of deep feeling as could occur only where officers reposed the highest confidence in their commander, who had led them successfully through some of the most fearful battles of modern wars. Monday was occupied in passing among the various camps, reviewing the troops, and taking a final leave of both officers and men. A spectator of these scenes has summed them up in these words:

"As Gen. McClellan, mounted upon a fine horse, attended by a retinue of fine-looking military men, riding rapidly through the ranks, gracefully recognized and bid a farewell to the army, the cries and demonstrations of the men were beyond bounds—wild, impassioned, and unrestrained. Disregarding all military forms they rushed from their ranks and thronged around him with the bitterest complaints against those who had removed from command their beloved leader."

On the next day, the 10th, he withdrew, taking the railroad cars at Warrenton. On reaching Warrenton Junction a salute was fired. The troops, which had been drawn up in line, afterward broke ranks, when the soldiers crowded around him and many eagerly called for a few parting words. He said in response, while on the platform of the railroad depot, "I wish you to stand by Gen. Burnside as you have stood by me, and all will be well. Good-bye." To this there was a spontaneous and enthusiastic response.

The troops were also drawn up in line at Bristow's Station and Manassas Junction, where salutes were fired and he was complimented with enthusiastic cheers. On reaching Washington he proceeded immediately to the depot, and passed on to Philadelphia and Trenton, where he arrived early on the 12th.

What was now the military aspect? The movement of Gen. McClellan's army, after crossing the Potomac, was toward Gordonsville. This made a movement on the part of the Confederate general Lee necessary in order to prevent the Federal army from getting between him and Richmond. For this purpose he attempted to move from Winchester through the

gaps of the Blue Ridge to Culpepper. The larger part of his force had passed through, when the gaps were taken and held by Gen. McClellan. At the same time Gen. Sigel had advanced from Washington, and lay near the Blue Ridge, covering at once Washington, observing the gaps to the Rappahannock, and protecting the railroad communication to that river. The bridge at Rappahannock Station had already been seized by the cavalry, under Gen. Bayard. The available force of Gen. McClellan was about one hundred and twenty thousand men; that of Gen. Lee consisted of about sixty thousand able men at Culpepper and Gordonsville, and thirty thousand in the Shenandoah Valley, near Strasburg. The distance from Warrenton to Gordonsville is about fifty miles, and from Warrenton to the Rapidan, thirty-five miles; from Strasburg to Gordonsville, by Staunton and Charlottesville, one hundred and thirty-five miles; and by the only other practicable route, one north-west of Gordonsville, and perpendicular to Gen. McClellan's line of advance, about one hundred miles. In his position it was necessary for Gen. Lee to defend the line of the Rapidan, or endeavor to effect a junction with the force in the Shenandoah Valley, under Gen. Jackson, or fall back upon Richmond, in a country without a line of defence, with Gen. McClellan close upon him, leaving Gen. Jackson to shift for himself. The defence of the Rapidan was impracticable from the course of the river from the Alexandria railroad to the Blue Ridge. The efforts to join Gen. Jackson would have uncovered Richmond, and the attempt to fall back on Richmond would have at least hazarded the demoralization of his army, and enabled Gen. McClellan to turn the defensible parts of the Rappahannock, and the line of the North Anna. The appointment of Gen. Burnside was followed by the organization of a portion of the army into divisions, and a movement to concentrate it at Fredericksburg. On the 12th Gen. Burnside issued the following address to the army:

HEADQUARTERS ARMY OF THE POTOMAC, Nov. 10, 1862.

In accordance with General Orders, No. 132, issued by the President of the United States, I hereby assume command of the Army of the Potomac. Patriotism, and the exercise of my every energy in the direction of this army, aided by the full and hearty coöperation of its officers and men, will, I hope, under the blessing of God, insure its success.

Having been a sharer of the privations, and a witness of the bravery of the old Army of the Potomac in the Maryland campaign, and fully identified with them in their feelings of respect and esteem for Gen. McClellan, entertained through a long and most friendly association with him, I feel that it is not as a stranger I assume command.

To the 9th army corps, so long and intimately associated with me, I need say nothing. Our histories are identical. With diffidence for myself, but with a proud confidence in the unswerving loyalty and determination of the gallant army now intrusted to my care, I accept its control, with the steadfast assurance that the just cause must prevail.

[Signed]

A. E. BURNSIDE,  
Major-General Commanding.

On the 12th the general-in-chief (Halleck)

and Gen. Meigs proceeded from Washington to the headquarters to confer with Gen. Burnside. On the same day the advance of the army was across the Rappahannock and fifteen miles south of Warrenton. On the 14th Gen. Burnside issued the following order reorganizing a portion of his army:

HEADQUARTERS, ARMY OF THE POTOMAC, }  
WARRENTON (VA.), Nov. 14, 1862. }

General Order, No. 184.

First. The organization of a portion of this army in three grand divisions is hereby announced. These grand divisions will be formed and commanded as follows:

The Second and Ninth Corps will form the right grand division, and will be commanded by Maj.-Gen. E. V. Sumner.

The First and Sixth Corps will form the left grand division, and will be commanded by Maj.-Gen. W. B. Franklin.

The Third and Fifth Corps will form the centre grand division, and will be commanded by Maj.-Gen. Joseph Hooker.

The Eleventh Corps, with such others as may hereafter be assigned to it, will constitute a reserve force, under the command of Maj.-Gen. F. Sigel.

Assignments of cavalry and further details will be announced in future orders.

By command of Maj.-Gen. BURNSIDE.

S. WILLIAMS, A. A.-G.

A movement was made at this time by Gen. Jackson for the purpose of detaching a portion of the army of the Potomac. He occupied all the roads west and north of Winchester as far as Big Cacapon Bridge on the northwestern turnpike, and from Pughtown to Bath and Hancock. He was thus looking westward, at the same time he was in a position to cross the Potomac. His movement failed to effect his design.

Meanwhile the mass of Gen. Lee's forces retired to Gordonsville. On the 16th the forces of Gen. Burnside began to move for Fredericksburg, as had been previously determined in consultation on the 12th between Gens. Halleck and Burnside. On the 15th the evacuation of Warrenton and the adjacent places was commenced, and by the morning of the 18th it was entirely completed. The advance was led by Gen. Sumner. At the same time supplies were sent to Aquia Creek, and the repairs of the railroad track to Fredericksburg commenced, and the army concentrated at Falmouth opposite Fredericksburg.

The march to Richmond, it appeared, was to be made by the route from Fredericksburg. This city is on the south bank of the Rappahannock, and sixty-five miles distant from Richmond. It is connected with the latter place by a railroad, of which there is a double line nearly to Hanover Junction, twenty-three miles from Richmond. The railroad crosses the Mataponi river at Milford, thirty-seven miles from Fredericksburg, and the Pamunkey, twenty-five miles from Richmond, besides a number of smaller streams. Between Falmouth, where the Federal army concentrated, and Richmond there are two main and two minor lines of de-

fence. The first that of the Rappahannock river. Above Falmouth its abrupt banks, which are lined with high hills, difficult of access, and its narrow fords and rocky bottom render a rapid crossing for a large force almost impossible. Below, the valley of the river expands, spreading often into spacious plains, while the winding course of the stream forms numerous necks of land, easily commanded from the north side, and giving secure crossing places, and ample ground for the formation of troops. At Fredericksburg the north commands the south bank and much of the distance, which is a mile and a half, to the frowning hills or table land beyond. But these heights equally command this intermediate plain, and are unassailable in front except by infantry. Next in the rear and twelve miles distant, is the line of the Po river and Stannard's Marsh, which is hardly available except to hold a pursuing foe in check. The North Anna is about forty miles from the Rappahannock, and affords another principal line of defence. It is a deep and rapid stream, with a narrow valley. The table land on its north bank is about one hundred feet above the bed of the river, and about one hundred and fifty on the south bank. The extension of its line after it turns to join the South Anna, and becomes the Pamunkey, presents scarcely less obstacles than the river itself, so well is the ground guarded by swamps and flanked by streams. The last and a minor line of defence is the South Anna river, with the southern commanded by the northern bank, and too near the North Anna for a second formation by a force that has been badly defeated. Numerous small streams parallel to the line of advance present suitable points for resistance, and protect foes attacking the line of communication, while the bridges over them are weak points necessary to be securely guarded.

By the 20th a considerable force had reached Falmouth. Gen. Sumner on the next day sent to Fredericksburg the following summons to surrender:

HEADQUARTERS ARMY OF THE POTOMAC, Nov. 21, 1862.

*To the Mayor and Common Council of Fredericksburg:*

GENTLEMEN: Under cover of the houses of your city shots have been fired upon the troops of my command.

Your mills and manufactories are furnishing provisions and materials for clothing for armed bodies in rebellion against the Government of the United States; your railroads and other means of transportation are removing supplies to the depots of such troops.

This condition of things must terminate, and by direction of Gen. Burnside, I accordingly demand the surrender of the city into my hands, as the representative of the Government of the United States, at or before five o'clock this afternoon.

Failing an affirmative reply to this demand by the hour indicated, sixteen hours will be permitted to elapse for the removal from the city of women and children, the sick and wounded, and aged, &c.; which period having expired, I shall proceed to shell the town.

Upon obtaining possession of the city, every necessary means will be taken to preserve order and secure

the protective operation of the laws and policy of the United States Government.

I am, very respectfully, your obedient servant,  
E. V. SUMNER,

Brevet Maj.-Gen. U. S. Army,  
Commanding Eighth Grand Division.

In reply the mayor of the city, M. Slaughter, stated that the firing complained of occurred in the suburbs, and was the act of the Confederate officer in command, for which neither the citizens nor authorities were responsible. The other matters complained of, he said, should no longer exist, and proceeded thus: "The civil authorities of Fredericksburg have no control; but I am assured by the military authorities of the Confederate army near here that nothing will be done to infringe the conditions herein named, as to matters within the town; but the latter authorities inform us that, while their troops will not occupy the town, they will not permit yours to do so."

The late hour at which the summons was received rendered it impossible to remove the women and children in the time allowed.

The reply of Gen. Sumner to the mayor was as follows:

HEADQUARTERS RIGHT GRAND DIVISION, CAMP NEAR }  
FALMOUTH, Nov. 21, 1862. }

*To the Mayor and Common Council of Fredericksburg:*

Your letter of this afternoon is at hand, and in consideration of your pledge that the acts complained of shall cease, and that your town shall not be occupied by any of the enemy's forces, and your assertion that a lack of transportation renders it impossible to move the women, children, sick, wounded, and aged, I am authorized to say to you that our batteries will not open upon the town at the hour designated. Gen. Patrick will meet a committee of representatives from your town to-morrow morning at nine o'clock at the Lacy House.

Very respectfully your obedient servant,  
E. V. SUMNER,  
Brevet Maj.-Gen. Commanding Division.

An interview was subsequently held as above mentioned, which resulted in the following note from Gen. Sumner:

HEADQUARTERS RIGHT GRAND DIVISION, Nov. 22, 1862.

*To the Mayor and Common Council, Fredericksburg:*

I am authorized to say that so long as no hostile demonstration is made from the town it will not be shelled. I have also to say that there will be no firing upon the cars before 11 o'clock p. m. to-morrow.

I am, gentlemen, your obedient servant,  
E. V. SUMNER,  
Brevet Maj.-Gen. U. S. A., Commanding.

The firing upon the cars of the railroad above mentioned was in consequence of the belief that they were used to remove military stores from Fredericksburg.

As Gen. Burnside's army concentrated on the north bank, Gen. Lee's forces concentrated on the heights in the rear of Fredericksburg. Had the pontoon bridges required been at hand when the advance reached Falmouth, the line of the Rappahannock would have been taken without opposition. Then, with proper supplies and bridges, thirty of the sixty miles to Richmond would have been placed within the reach of Gen. Burnside, and perhaps a lodg-

ment have been effected on the banks of the North Anna. Nearly thirty days elapsed before the pontoons arrived and the bridges were completed. The ensuing military operations were investigated by a committee of Congress, before whom Gen. Burnside testified as follows:

Gen. Halleck came down to see me on the 11th of November. On the 9th I made out a plan of operations, in accordance with the order of Gen. Halleck, which directed me not only to take the command, but also to state what I proposed to do with it. That plan I wrote on the morning of the 9th of November, and sent it by special messenger to Washington. I can furnish the committee a copy of that plan if they desire it. I do not have it here now.

Question.—State the substance of it, if you please. That may do as well.

Answer.—I stated, in substance, that I thought it advisable to concentrate the army in the neighborhood of Warrenton, to make a small movement across the Rappahannock as a feint, with a view to divert the attention of the enemy, and lead them to believe we were going to march in the direction of Gordonsville, and then to make a rapid movement of the whole army to Fredericksburg, on this side of the Rappahannock.

As my reasons for that, I stated that the farther we got into the interior of Virginia, the longer would be our lines of communication and the greater would be the difficulty we would have in keeping them open, as the enemy had upon our right flank a corps that almost at any time could, by a rapid movement, seriously embarrass us. If we were caught by the elements so far from our base of supplies, and at the same time in the enemy's country, where they had means of getting information that we had not, it might, I thought, prove disastrous to the army, as we had but one line of railway by which to supply it.

In moving upon Fredericksburg we would all the time be as near Washington as would the enemy, and after arriving at Fredericksburg, we would be at a point nearer to Richmond than we would be even if we should take Gordonsville. On the Gordonsville line, the enemy, in our opinion, would not give us a decisive battle at any place this side of Richmond. They would defend Gordonsville until such time as they felt they had given us a check, and then with so many lines of railroad open to them, they would move upon Richmond or upon Lynchburg, and in either case the difficulty of following them would be very great.

In connection with this movement I requested that barges filled with provisions and forage should be floated to Aquia Creek, where they could easily be landed; that materials be collected for the reconstruction of the wharves there, and that all the wagons in Washington that could possibly be spared should be filled with hard bread and small commissary stores, and, with a large number of beef cattle, started down to Fredericksburg on the road by way of Dumfries; and that this wagon train and load of cattle should be preceded by a pontoon train large enough to span the Rappahannock twice. I stated that this wagon train could move in perfect safety, because it would be all the time between our army and the Potomac; or in other words our army would be all the time between the enemy and that train. But at the same time I said that if a cavalry escort could not be furnished from Washington, I would send some of my cavalry to guard the train.

On the morning of the 14th of November, feeling uneasy with reference to the pontoons, as I had not heard of their starting, I directed my chief engineer to telegraph again in reference to them.

He telegraphed to Gen. Woodbury or to Major Spaulding. It subsequently appeared that that was the first they ever had heard of any wish to have the pontoon train started down to Fredericksburg, although the authorities in Washington had had my plans sent

to them on the 8th of November; and it had also been discovered by Gen. Halleck and Gen. Meigs, at my headquarters, on the night of the 11th and 12th of November; and after discovering it fully there, they sat down and sent telegrams to Washington, which, as I supposed, fully covered the case, and would secure the starting of the pontoon trains at once. I supposed, of course, that those portions of the plan which required to be attended to in Washington would be carried out there at once. I could have sent officers of my own there to attend to those matters, and perhaps I made a mistake in not doing so, as Gen. Halleck afterward told me that I ought not to have trusted to them in Washington for the details.

In reply to the telegram I had ordered to be sent, Gen. Woodbury telegraphed back that the pontoon train would start on Sunday morning probably, and certainly on Monday morning, which would have been on the 16th and 17th of November, and would have been in time. They did not, however, start until the 20th, and on that day it commenced raining, which delayed them so much and the roads became so bad that when they got to Dumfries they floated the pontoons off the wagons. We then sent to Washington for a steamer, and carried them down to Aquia Creek by water, sending the wagons around by land. The pontoons did not get here until the 22d or 23d of November.

On the 15th of November I started the column down the road to Fredericksburg, not knowing anything about the delay in the starting of the pontoons, because the telegram announcing the delay did not reach Warrenton Junction until I had left to come down here with the troops, and that telegram did not reach me until I arrived here on the morning of the 19th, when it was handed to me by an orderly who had brought it down to Warrenton Junction.

After reaching here I saw at once that there was no chance for crossing the Rappahannock with the army at that time. It commenced raining and the river began to rise—not to any great extent, but I did not know how much it might rise. There were no means of crossing except by going up to the fords, and it would be impossible to do that because of the inability to supply the troops after they should cross.

Gen. Sumner, with his command, arrived here in advance. He sent to me, asking if he should cross the river. He was very much tempted to take his own men across to Fredericksburg by a ford near Falmouth, as there was no enemy there except a very small force. I did not think it advisable that he should cross at that time.

The plan I had in contemplation was, if the stores and these bridges had come here as I expected, to throw Sumner's whole corps across the Rappahannock, fill the wagons with as many small stores as we could, and having beef cattle along for meat, then to make a rapid movement down in the direction of Richmond and try to meet the enemy and fight a battle before Jackson could make a junction there. We knew that Jackson was in the valley, and felt confident that there was force enough on the upper Rappahannock to take care of him. We felt certain that as soon as the enemy knew of our crossing down here, the force of Jackson would be recalled, and we wanted to meet this force and beat it before Jackson could come down on our flank and perhaps cripple us.

I had recommended that some supplies should be sent to the mouth of the Rappahannock with a view of establishing a department at Port Royal. After we had advanced to Fredericksburg, and after the first delay in starting the pontoons, I think they were sent as quickly as they could have been, and the supplies and quartermasters' stores have been always in as great abundance as we could have expected, for after the 19th of November the roads were particularly bad. Horses and mules were sent down to us, so that our cavalry and teams were in very good condition.

After it was ascertained that there must be a delay, and that the enemy had concentrated such a force

as to make it very difficult to cross, except by a number of bridges, we commenced bringing up from Aquia Creek all the pontoons we could. After enough of them had been brought up to build the bridges, I called several councils of war to decide about crossing the Rappahannock. It was at first decided to cross at Shinker's Neck, about twelve miles below here, but our demonstration was simply for the purpose of drawing down there as large a force of the enemy as possible.

I then decided to cross here because, in the first place, I felt satisfied that they did not expect us to cross here but down below. In the next place I felt satisfied that this was the place to fight the most decisive battle, because if we could divide their forces by penetrating their lines at one or two points, separating their left from their right, then a vigorous attack with the whole army would succeed in breaking their army in pieces.

The enemy had cut a road along on the rear of the line of the heights where we made our attack, by means of which they connected the two wings of their army, and avoided a long detour round through a bad country. I obtained from a colored man from the other side of the town information in regard to this new road, which proved to be correct. I wanted to obtain possession of the new road, and that was my reason for making an attack on the extreme left. I did not intend to make the attack on the right until that position had been taken, which I supposed would stagger the enemy, cutting their lines in two. And then I proposed to make a direct attack on their front, and drive them out of the works.

By Mr. Gooch: Do I understand you to say that it was your understanding that Gen. Halleck and Gen. Meigs, while at your headquarters in Warrenton, and before you commenced the movement of your army, sent orders to Washington for the pontoons to be immediately forwarded to Falmouth?

Answer: That was my understanding, certainly.

Question: In your judgment, could the pontoons have been forwarded to you in time for you to have crossed the Rappahannock when you expected, if all possible efforts had been made by those charged with that duty?

Answer: Yes, sir, if they had received their orders in time.

Question: Did the non-arrival of these pontoons at the time you expected prevent your crossing when you expected to cross and interfere with the success of your plans?

Answer: Yes, sir.

Thus it was the design of Gen. Burnside that the pontoons should leave Alexandria on Nov. 11, and arrive at Falmouth at the same time with the advance of his army. The right grand division reached Falmouth on Nov. 17. The pontoons left Alexandria on Nov. 19, and arrived at Fredericksburg after the movements of Gen. Burnside had not only become known, but after Gen. Lee had advanced his forces from Gordonsville to the heights in the rear of Fredericksburg, and had fortified them. They were not used until the night of Dec. 10.

A plan for the movements of Gen. Burnside had now been arranged between President Lincoln, Gen. Halleck, and himself, by which it was determined that the army should move across the Rappahannock at a certain place and at a certain time. This was departed from by Gen. Burnside, who was induced to move the army across at a different place and at an earlier day. His reasons for this change he thus states in his report:

During my preparations for crossing at the place

I had first selected, I discovered that the enemy had thrown a large portion of his force down the river and elsewhere, thus weakening his force in front, and also thought I discovered that he did not anticipate the crossing of our whole force at Fredericksburg, and I hoped by rapidly throwing the whole command over at that place to separate by a vigorous attack the forces of the enemy on the river below from the force behind and on the crest in the rear of the town, in which case we could fight him with the greatest advantage in our favor. To do this we had to gain a height on the extreme right of the crest, which height commanded a new road lately made by the enemy for the purpose of more rapid communication along his lines; which point gained, his position along the crest would have been scarcely tenable, and he could have been driven from them easily by an attack on his front in connection with a movement in rear of the crest.

During the night of the 10th of December, therefore, the pontoons were conveyed to the river, and the artillery to the number of one hundred and forty-three pieces was placed in position opposite the city. Between four and five o'clock on the morning of the 11th, the work of building four bridges was commenced. One was to be made at the point where the railroad bridge formerly crossed, and two others opposite the city but nearer Falmouth, and the fourth nearly two miles below for the crossing of the left wing under Gen. Franklin. A dull haze so obscured the movement, that it was not discovered for some time by the Confederate pickets. The bridges were thus partly constructed, when a brisk and deadly fire of musketry from along the banks of the river and windows of the houses was opened, which compelled the workmen to stop. They fled to the cover of the surrounding hills where they formed again, and about six o'clock the work was recommenced. The Confederates had now become aroused to a sense of what was going forward, and with reinforcements of sharpshooters swarmed the opposite bank and houses. The pontonniers, nothing daunted by the hot fire poured upon them, went bravely to work. A storm of bullets covered them. The planks and boats were riddled by every volley. Once more they were compelled to withdraw, and again fell back to the cover of the ridge of hills running parallel with the river. Orders were now given to the artillery to open fire on the city. The Federal batteries commenced an almost simultaneous bombardment, directing their fire chiefly at the houses in which the sharpshooters had concealed themselves. At the first fire they became untenable, and the riflemen retreated to the rear of the town, and took shelter behind the buildings unharmed. The fire of the artillery, which commenced at seven o'clock, was continued incessantly until one o'clock. The fog somewhat obscured its results, but bodies of the Confederates with great stubbornness still kept within the city. The Confederate batteries on the heights in the rear continued silent. Not a gun was fired. About ten o'clock, the workmen were again formed for a third attempt to build the bridges. Vol-

unteers joined them from the 8th Connecticut. Some planks were seized and carried out to the end of a string of boats and placed in position, when a galling fire from sharpshooters in rifle pits near the edge of the water again interrupted them, and they were recalled. Meantime the bombardment was continued, and several houses in the city had taken fire. In the afternoon, several pontoon boats, loaded with volunteers from the 7th Michigan and 19th Massachusetts, were sent over. They chased the Confederate sharpshooters from their hiding places, and the bridges were finished without further interruption. On the other side a scene of destruction presented itself. The walls of houses were breached, roofs had fallen in, and the interiors were destroyed.

No sooner were the bridges completed than the troops began to cross, and before dusk Gen. Sumner's grand division had gone over, and a section of Gen. Hooker's. All had rations for three days, and blankets for a bivouac. The grand division of Gen. Franklin, consisting of the corps of Gens. Reynolds and Smith, crossed over at the lower bridge, which was built earlier in the day without interruption, as there was a plain before it which the artillery could easily have swept. The troops commenced crossing again early on the morning of the 12th without molestation. Some sharp resistance had been made by the Confederate soldiers to those who crossed on the previous day, but these were driven out of the city or killed. During the afternoon fire was opened upon the city by the Confederate batteries on the nearest heights, which was replied to by the Federal batteries, and soon ceased. The occupation of Fredericksburg had now been successfully made. No greater opposition had been presented by the forces of Gen. Lee than was sufficient to tempt the Federal troops to press forward with greater ardor.

The next movement was to drive the Confederate forces from their positions on the heights. These positions consisted of two lines of batteries, one a mile in rear of the other, and both overlooking the city. They extended, in the form of a semicircle, from Port Royal to a point about six miles above Fredericksburg. Their right wing, under Gen. Jackson, extended from Port Royal to Guinney's Station on the Richmond and Fredericksburg railroad; the centre, under Gen. Longstreet, extended to the telegraph road; the left, under Gen. Stuart, was west of Massaponax Creek. A reserve corps was commanded by Gen. A. P. Hill. This was the force which had fought at Richmond and in Maryland.

Friday night and Saturday morning, the 13th, were spent by Gen. Burnside in making a proper disposition of his forces. The left was occupied by Gen. Franklin with his grand division, the centre by Gen. Hooker, and the right by Gen. Sumner.

The right of Gen. Franklin rested on the outskirts of the city, his centre was advanced

about a mile from the river, and his left was on the Rappahannock, about three miles below. The action commenced on the extreme left by an annoying fire from a Confederate battery, which the 9th New York was ordered to charge and capture. In this attempt they were repulsed. A brigade was brought to their aid by Gen. Tyler, and another attempt made, but the fire was so deadly that it failed of success. The battle now became more general, and another attempt was made to capture the battery. No advantage was gained at this time, but a severe loss was suffered. The conflict now extended along the whole line of the left, and a desperate effort was made to drive the Confederates across the Massaponax Creek by turning their position. The ground was contested most obstinately, but the Confederates gradually fell back, occasionally making a most desperate stand, until night, when Gen. Franklin had succeeded in gaining nearly a mile, and his troops occupied the field. The right of Gen. Franklin's division, under Gen. Reynolds, encountered the fire of the Confederate artillery on the heights, and although the conflict was most deadly, no advantage was gained.

On the right, under command of Gen. Sumner, the action commenced about ten o'clock and was furious during the rest of the day. The Confederate forces occupied the woods and hills in the rear of the city, from which it soon became evident they could not be driven except at the point of the bayonet. The charge was ordered to be made by the division of Gen. French supported by that of Gen. Howard. Steadily the troops moved across the plain, until they were within a dozen yards of the ridge, when they were suddenly met by a galling fire from the Confederate infantry posted behind a stone wall. For a few minutes the head of the column exhibited some confusion; but quickly forming into line it retired back to a ravine within musket shot of the Confederates. Here they were reinforced by fresh troops who fearlessly advanced to their aid under a most destructive fire of artillery. The line of assault was now formed again, and with bayonets fixed and a double-quick step, they rushed forward to seize the Confederate artillery. From the first step they encountered a terrific fire of infantry and artillery. No veterans could face that shock. They were thrown into confusion and brought to a sudden halt. At this juncture the centre quivered, faltered, and fled in disorder, but was afterward rallied and brought back. Three times was the attack thus made to dislodge those batteries. But each time it was in vain. The ranks of the storming party, shrunk to small limits, retired. The entire force of his artillery was now brought by Gen. Sumner to bear upon the enemy, and thus the contest was kept up until dark. At night the Confederate force occupied their original position, and the wounded and the dead remained where they



had fallen. Every attempt to remove them by the Federal troops was defeated by the Confederate infantry.

In the centre, under the command of Gen. Hooker, skirmishing commenced early in the morning; and during the forenoon, while the fog prevailed, a terrific contest, chiefly with artillery, was kept up on both sides. The Confederate position appeared to be invulnerable to artillery, and about noon preparations were made for storming it. The troops marched steadily up within musket shot of the batteries, and were there met by such a destructive fire of artillery and rifles as drove them back with a heavy loss. Reinforcements were obtained, and the attempt to take the batteries was repeated in the afternoon, but without success. The contest continued with great fierceness until night. About half past five the firing of musketry ceased, but that of the artillery continued until long after dark.

On the next day, Sunday the 14th, both armies remained comparatively quiet. Some skirmishing and artillery fire took place for a short time. Gen. Burnside sent the following despatch to President Lincoln early in the morning:

HEADQUARTERS ARMY POTOMAC, }  
FOUR O'CLOCK, A. M., December 14. }

THE PRESIDENT: I have just returned from the field. Our troops are all over the river and hold the first ridge outside the town and 3 miles below. We hope to carry the crest to-day. Our loss is heavy—say 5,000.

A. E. BURNSIDE,  
Major-General Commanding.

On Monday, both armies continued in the same position. The Confederates had strengthened some of their works. During the ensuing night, the army evacuated Fredericksburg and retired across the river to its former position. The artillery crossed first, followed by the infantry, the last of whom left about daylight. The pontoon bridges were then removed and all communication cut off. The movement was not perceived by the Confederates until it was too late to do any injury to the retreating force. The following is the despatch of Gen. Burnside announcing this movement:

HEADQUARTERS ARMY POTOMAC, }  
SIX O'CLOCK P. M., December 16, 1862. }

Maj.-Gen. HALLECK: The army was withdrawn to this side of the river because I felt the position in front could not be carried, and it was a military necessity either to attack or retire. A repulse would have been disastrous to us. The army was withdrawn at night, without the knowledge of the enemy, and without loss either of property or men.

A. E. BURNSIDE,  
Major-General Commanding.

The Federal loss was as follows: Gen. Sumner's division on the right, killed, 473; wounded, 4,090; missing, 748. Total, 5,311.

Gen. Hooker's division on the centre, killed, 326; wounded, 2,468; missing, 754. Total, 3,548.

Gen. Franklin's division on the left, killed, 389; wounded, 2,547; missing, 576. Total,

3,462. Grand total, killed, 1,188; wounded, 9,105; missing, 2,078. Total, 12,321.

The Confederate loss was comparatively small, having been sheltered by their works.

Gen. Burnside, in his report to the general-in-chief, thus explains his defeat:

How near we came to the accomplishment of our object future reports will show. But for the fog, and the unexpected and unavoidable delay in building the bridges, which gave the enemy 24 hours to concentrate his forces in his strong position, we would almost certainly have succeeded, in which case the battle would have been, in my opinion, far more decisive than if we had crossed at the places first selected. As it was, we came very near success. Failing in accomplishing the main object, we remained in order of battle two days, long enough to decide that the enemy would not come out of his strongholds to fight me with his infantry, after which we recrossed to this side of the river unmolested, without the loss of men or property.

As the day broke our long lines of troops were seen marching to their different positions as if going on parade—not the least demoralization or disorganization existed.

To the brave officers and soldiers who accomplished the feat of thus recrossing in the face of the enemy, I owe everything. For the failure in the attack, I am responsible, as the extreme gallantry, courage, and endurance shown by them were never exceeded, and would have carried the points had it been possible.

To the families and friends of the dead I can only offer my heartfelt sympathies, but for the wounded I can offer my earnest prayer for their comfort and final recovery.

The fact that I decided to move from Warrenton on to this line rather against the opinion of the President, Secretary of War, and yourself, and that you have left the whole movement in my hands, without giving me orders, makes me the more responsible.

Thus closed the third campaign against Richmond. No further hostile demonstrations were made by either army during the year. On the 31st of December, the Confederate general Lee issued the following address to his troops:

HEADQUARTERS ARMY OF NORTHERN VIRGINIA, }  
Dec. 21, 1862. }

General Order, No. 88.

1. The General commanding takes this occasion to express to the officers and soldiers of the army his high appreciation of the fortitude, valor, and devotion displayed by them, which, under the blessing of Almighty God, have added the victory of Fredericksburg to the long lists of their triumphs.

An arduous march, performed with celerity under many disadvantages, exhibited the discipline and spirit of the troops and their eagerness to confront the foe.

The immense army of the enemy completed its preparations for the attack without interruption, and gave battle in its own time, and on ground of its own selection.

It was encountered by less than twenty thousand of this brave army, and its columns, crushed and broken, hurled back at every point with such fearful slaughter that escape from entire destruction became the boast of those who had advanced in full confidence of victory.

The war is not yet ended. The enemy is still numerous and strong, and the country demands of the army a renewal of its heroic efforts in her behalf. Nobly has it responded to her call in the past, and she will never appeal in vain to its courage and patriotism.

The signal manifestations of Divine mercy that have distinguished the eventful and glorious campaign of the year just closing, give assurance of hope that, under the guidance of the same Almighty hand, the com-

ing year will be no less fruitful of events that will insure the safety, peace, and happiness of our beloved country, and add new lustre to the already imperishable name of the Army of Northern Virginia.

R. E. LEE, General.

As a part of the campaign against Richmond undertaken when Gen. Burnside took command of the army in Virginia, the efforts which were made to cut the Confederate line of communication between Richmond and the southwestern States, should be stated. There are three lines of railroad running south and southwest. The one running southwest passes through southwestern Virginia, eastern Tennessee, northern Alabama, and connects with roads to western Tennessee and to New Orleans. One line running south connects Richmond with Wilmington, Charleston, Savannah, and parts of Alabama. A southern line from Richmond, recently completed, passes through central North Carolina and South Carolina. By cutting the former of these roads at Cumberland Gap, reinforcements and supplies could not be brought from the southwest to the Confederate army under Gen. Lee. Neither could reinforcements be taken from Gen. Lee's army to Gen. Bragg at Murfreesborough. By cutting the second line the most direct communication between Richmond and the principal cities of the Confederate States was destroyed.

At the time when Gen. Rosecrans was prepared to move from Nashville to attack the Confederate army near Murfreesborough, an expedition was sent into east Tennessee to destroy the railroad, in order to prevent any reinforcements to Gen. Bragg from Richmond. Gen. Carter, with a force of cavalry numbering one thousand men, left London, in Kentucky, on Dec. 21. They entered Virginia between Cumberland Gap and Pound Gap, and advanced within six miles of Bristol, burned the bridges across the Halston and Watauga rivers, and tore up portions of the track, destroying the rails for a distance of nearly one hundred miles, almost to Jonesborough. They captured nearly five hundred prisoners, seven hundred stand of arms, and a large amount of stores. They reached Manchester, Ky., on the 6th of January, having lost only ten men. The enterprise was a most hazardous one.

The expedition against the second line of railroads was undertaken in North Carolina. It forms the only subsequent military movement of importance, in addition to those heretofore described, which was made in that department during the year. It was a march upon Goldsborough, and the destruction of the railroad at that place. This is the line connecting Charleston and Savannah with Richmond. Gen. J. G. Foster, who commanded the department after the departure of Gen. Burnside, took charge of the expedition. The force consisted of four brigades under Cols. Wessels, Amory, Stevenson, and Lee; the 3d New York and 1st Rhode Island batteries; also sec-

tions of the 23d and 24th New York Independent batteries, and the 3d New York cavalry. It left Newbern on the morning of Dec. 11, and moved on the Kinston road fourteen miles. Some parts of the road were obstructed by felled trees. On the next morning it advanced to the Vine Swamp road, having some sharp skirmishing with a small Confederate force. At this point three companies of cavalry were sent up the Kinston road as a demonstration, and the main force took the Vine Swamp road, thereby avoiding the obstructions and the Confederate forces. It was delayed to build the bridge over Beaver Creek, where the 51st Massachusetts and a section of artillery were left to hold it, and support the cavalry on the main road, and halted at a distance of four miles. The next morning the main column advanced, turning to the left and leaving the road it was upon to the right. At the intersection the 48th Massachusetts and a section of a battery were left as a feint and to hold the position. On reaching Southwest Creek a Confederate force was found posted on the opposite bank, about four hundred strong, and with three pieces of artillery. The creek was not fordable, and ran at the foot of a deep ravine. Under the protection of a battery the 9th New Jersey effected a passage and formed on the opposite bank, where it was afterward supported by the 85th Pennsylvania. This caused the Confederate force to retire with some skirmishing. On the next day an advance upon Kinston was made, and the Confederate force found posted in a strong position about one mile from the place. An attack was at once made with the 9th New Jersey in advance, and the position taken. The Confederate force retired across the Neuse river, with a loss of four hundred prisoners. On crossing, the bridge was set on fire, but soon extinguished by the advance of Gen. Foster. The bridge was immediately repaired, and the column crossed, and occupied the town of Kinston. With constant skirmishing the force of Gen. Foster continued to advance until the 17th, when it reached Goldsborough. Here it burned two trestle-work culverts, destroyed a train of four railroad cars, water station, depot, &c., and some small arms, which it was unable to carry off. After destroying other bridges, and capturing some small positions that had been occupied by a Confederate force, the expedition successfully returned to Newbern. This enterprise was very skilfully executed. In connection with movements upon Richmond it would have possessed considerable importance, but in the absence of such movements it only served to interfere for a few days with one line of the Confederate internal communication.

These expeditions, although successful in themselves, secured no important advantages as the great movement upon Richmond had, in the mean time, been suspended. They were useful reconnoissances, and the former may have

delayed the arrival of reinforcements from Gen. Lee to Gen. Bragg before the battle of Murfreesborough. They developed the importance of these roads to the Confederate Government, and proved that their permanent loss would have caused serious embarrassment to it.

Some military movements took place during the year, which have not been stated in the preceding pages, as they were rather isolated operations than a part of the campaign at the time progressing.

On the 6th of September a body of Confederate troops surprised the garrison at Washington in the department of North Carolina. A vigorous resistance was made, and the attacking party was repulsed with a loss of thirty-three killed, and nearly one hundred wounded. The Federal loss was eight killed, and thirty-three wounded.

On the 22d of October an expedition was sent out from Port Royal in the department of the South, which was then under the command of Gen. Mitchell, to destroy the trestle-work bridges of the Charleston and Savannah railroad across the Pocotalico, Tullifinny, and Coosawhatchie, tributaries of the Broad river, and to make a reconnaissance of these streams. The expedition was under the command of Gens. Brannan and Terry. The main body of the troops was landed at Mackey's Point, about fifteen miles from the railroad, and marched seven miles inland, where the Confederates were met in force. After a sharp fight of an hour they retired to a point two miles distant and made a second stand. From this point they again fell back to the village of Pocotalico, and having burned the long bridge across the stream, they were inaccessible. Meanwhile Col. Barton, with three hundred and fifty men, penetrated to the railroad at Coosawhatchie, and destroyed some of the rails, cut the telegraph wire, and fired upon a train containing troops. The engagement by the main force was severe, and the Federal loss was thirty-two killed, and one hundred and eighty wounded. The Federal force retired on the next day, having failed in the object of the expedition, except the reconnaissance. The Confederate loss has not been stated.

On the 5th of August an attack was made on Baton Rouge, in the Department of the Gulf, which was under the command of Gen. Butler. The Federal force at this city was under command of Brig.-Gen. Williams. The Confederate force making the attack was under the command of Gen. John C. Breckinridge. The contest was sharp and bloody, and the attack was successfully repulsed. The Federal loss was ninety killed, and two hundred and fifty wounded. Among the killed was Gen. Williams. Three hundred of the Confederates were reported to have been killed and buried by the force of Gen. Williams. The city was subsequently evacuated by the Federal force on May 16.

On the 24th of October Brig.-Gen. Weitzel

commanded an expedition from New Orleans to the west bank of the Mississippi in the La Fourche district. An engagement took place with a considerable Confederate force on the next day, about nine miles from Donaldsonville, in which they were defeated with the loss of their commander, and a large number killed and wounded, and two hundred and sixty-eight prisoners. The Federal loss was eighteen killed, and sixty-eight wounded. The entire district was subsequently occupied by the force of Gen. Weitzel. (See LOUISIANA). For further military operations, see NEW MEXICO and MINNESOTA.

Some serious conflicts with guerilla troops took place in Kentucky, Tennessee, and Missouri. For the particulars, see KENTUCKY, TENNESSEE, and MISSOURI.

The following list of the most important military events, with the date when they occurred, presents a more summary view of the great magnitude of the simultaneous operations:

Burnside sails.....	Jan.	12
Mill Springs (Ky.), battle.....	Jan.	19
Cedar Keys (Fla.), captured.....	Jan.	16
Fort Henry (Ky.), captured.....	Feb.	6
Roanoke Island (N. C.), captured.....	Feb.	7
Elizabeth (N. C.), captured.....	Feb.	8
Edenton (N. C.), captured.....	Feb.	12
Springfield (Mo.), captured.....	Feb.	14
Donelson (Ky.), captured.....	Feb.	16
Bowling Green (Ky.), evacuated.....	Feb.	17
Fayetteville (Ark.), occupied.....	Feb.	18
Clarkville (Tenn.), occupied.....	Feb.	19
Winton (N. C.), occupied.....	Feb.	20
Nashville (Tenn.), occupied.....	Feb.	24
Columbus (Ky.), evacuated.....	March	1
Fernandina (Fla.), captured.....	March	3
St. Mary (Fla.), captured.....	March	3
Pea Ridge (Ark.), battle.....	March	6, 7
Brunswick (Ga.), captured.....	March	8
Jacksonville (Fla.), captured.....	March	12
St. Augustine (Fla.), captured.....	March	14
Newbern (N. C.), captured.....	March	14
New Madrid (Mo.), captured.....	March	14
Washington (N. C.), captured.....	March	25
Shiloh (Tenn.), battle.....	April	6, 7
Island No. 10, evacuated.....	April	7
Huntsville (Ala.), captured.....	April	8
Decatur and Stevenson (Ala.), captured.....	April	9
Fort Pulaski (Ga.), captured.....	April	11
Fort Macon (N. C.), captured.....	April	25
New Orleans, captured.....	April	26
Yorktown (Va.), evacuated.....	May	8
Williamsburg (Va.), evacuated.....	May	6
Pensacola (Fla.), evacuated.....	May	9
Norfolk, captured.....	May	10
Baton Rouge, occupied.....	May	27
Corinth (Miss.), evacuated.....	May	29
Fair Oaks (Va.), battle.....	May	31
Fort Pillow, evacuated.....	June	5
Memphis (Tenn.), surrenders.....	June	6
Cross Keys, battle.....	June	8
Cumberland Gap, occupied.....	June	18
Seven days before Richmond.....	June 25, &c.	
Malvern Hill, battle.....	July	1
Baton Rouge, attack.....	Aug.	5
Cedar Mountain, battle.....	Aug.	9
Rappahannock Bridge.....	Aug.	23
Centreville (Va.), battle.....	Aug.	28
Manassas (Va.), battle.....	Aug.	30
Chantilly (Va.), battle.....	Sept.	1
Munfordsville (Ky.), battle.....	Sept.	14
South Mountain, battle.....	Sept.	14

Antietam, battle.....	Sept.	17
Inks (Miss.), battle.....	Sept.	19
Corinth (Miss.), battle.....	Oct.	4
Perryville (Ky.), battle.....	Oct.	8
Holly Springs (Miss.).....	Nov.	13
Cane Hill (Ark.), battle.....	Nov.	28
Crawford's Prairie (Ark.), battle.....	Dec.	7
Fredericksburg (Va.), battle.....	Dec.	18
Murfreesboro (Tenn.), battle.....	Dec.	31

What has been accomplished by the military operations of the year:—The State of Missouri has been relieved from invasion by the Confederate force. Half of Arkansas has been permanently occupied. The Confederate force has been driven from the Mississippi river except at Vicksburg and Port Hudson. Western and Middle Tennessee have been occupied, and the former and part of the latter held. Western Virginia has been retained by the Federal Government. Maryland exhibited her preference for the Union. Norfolk and Yorktown have been taken and held. The cities and towns on the coast of North Carolina, with few exceptions, are occupied by a Federal force. Fort Pulaski, commanding the entrance to Savannah, was captured, and the important points on the coast of Florida occupied. Pensacola and New Orleans were also taken, and nearly all of Louisiana brought under Federal control. The forces of the North have slowly but firmly advanced upon every side of the Confederacy, and permanently hold every important position which they have gained. The battle of Antietam secured the border States, and decided the physical supremacy of the Union in favor of the North.

**ASTRONOMICAL PHENOMENA AND PROGRESS.** The astronomical questions which during the year 1862 have taken precedence of all others, are those relating to the physical constitution of the sun, and the possible determination of some of the chemical elements composing that body. Next to these in order of interest, may yet perhaps be ranked the question of variability and disappearance of nebulae. Nearly the average fertility in new asteroids (or planetoids) has rewarded the faithful devotees of the telescope; and though the comets of the year have not been brilliant, they have exhibited some features of interest. For many points directly or indirectly connected with the subject of this article, the reader is referred to the titles, **EARTH**, and **AURORAS**.

*Asteroids.*—Jan. 27, 1862, asteroid (58), Calypso, discovered in 1859, by Dr. Luther, at Bilk, near Düsseldorf, and at the periods of its opposition to the sun in the two succeeding years not detected, was by the same observer, after careful preparation of an ephemeris and a search of three weeks, rediscovered. Aug. 13, 1861, Dr. Luther found a new asteroid, appearing as a star of the 11th magnitude, and which he named Niobe,—its number being supposed to be (71). Of the observations made by Dr. Peters, of Hamilton College Observatory, and all of them, as he supposed, on the recently

discovered Maja (66), Mr. T. H. Safford, of Cambridge Observatory, found on a careful computation that 8 consecutive ones did not agree with the others; and he was led to infer that they indicated another planet contiguous at the time. For this the name Feronia was afterward selected by Mr. Safford and Dr. Peters; it now stands as (71), Niobe, subsequently discovered, ranking as (72). April 7, 1862, an asteroid appearing of the 18th magnitude, was discovered near  $\beta$  Virginis, by Mr. H. P. Tuttle, at Cambridge Observatory; to this (73) the name Clytia was afterward given. This is the third discovery of the kind within 12 months, at the same observatory. Asteroid (74) was discovered by M. Tempel, Aug. 29, and named Galatea; and it is now probable that this was the asteroid observed, Sept. 25, by Mr. H. M. Parkhurst, of N. Y. An asteroid, supposed until recently to number (75), was discovered by Dr. Peters, Sept. 22; this, however, is now believed to be the true Daphne. (*See* below.)

M. D'Arrest, of the observatory of Copenhagen, Oct. 21, detected asteroid (76); and he commemorates this first discovery of the sort in a latitude so far north, by proposing for the planet a name from the Scandinavian mythology,—that of Freya, the hyperborean Venus. Including Feronia, this gives four asteroids for the year.

Some changes of name, as well as of order, among the asteroids have been made. To (69), announced in the first volume of the *Cyclopædia*, the name of Hesperia is assigned; that of Panopæa being given to (70). When M. Chacornac had found asteroid (59), he deferred the naming of it by courtesy to M. Le Verrier, principal of the observatory. The latter desired to have introduced what he considered a more useful system of naming than the present, and delayed accordingly; meanwhile, Von Littrow, who had chiefly calculated the orbit of the planet, suggested the name Elpis. Le Verrier having finally waived for the time his scruples, Chacornac requested Mr. Hind to furnish a name, and he selected that of Olympia. The name at first given to (61), Titania, having been previously appropriated to a satellite of Uranus, has been changed to Echo. One of the most interesting episodes of asteroid-finding is presented in the history of the supposed Daphne. May 22, 1856, M. Goldschmidt, of Paris, found a new asteroid (41), which during a few days longer was observed by himself and others. It soon grew faint and disappeared. Its return to opposition in Sept. 1857, was computed; and at the latter date a concerted search was made for it by astronomers of different countries. Goldschmidt announced what he supposed to be the rediscovered planet; but afterward finding a discrepancy in the elements of the bodies for the two years, he inferred that the planet of 1857 was not Daphne, and named it Pseudo-Daphne (56). At two succeeding oppositions, this planet was not seen; but it was

found again Aug. 27, 1861. M. Schubert has selected for it the name of Melete, daughter of Uranus. The true Daphne meantime escaped observation, until Aug. 31, 1862. Dr. Luther, at Bilk, detected an asteroid of the 11th magnitude, the resemblance of the plane of whose path to that of the missing planet led him to suspect that he had rediscovered it. His observations, extended to Sept. 11, render the identity almost certain; though to establish this positively will require a rigorous computation of all the observations of the two years, 1856 and 1862. This planet thus appears to stand at present both as (41) and (75); so that it must relinquish one or the other of these numbers. The name of asteroid (65) having also been changed, the following list of asteroids since the 50th presents, along with the years of discovery, the names and order according to the latest corrections.

1858. (51) Nemausa.	1861. (64) Angelina.
" (52) Europa.	" (65) Cybele.
" (53) Calypso.	" (66) Maja.
" (54) Alexandra.	" (67) Asia.
" (55) Pandora.	" (68) Leto.
[1857.] (56) Melete.	" (69) Hesperia.
1859. (57) Mnemosyne.	" (70) Panopæa.
1860. (58) Concordia.	" (71) Feronia.
" (59) Olympia.	" (72) Niobe.
" (60) Danaë.	1862. (73) Clytia.
" (61) Echo.	" (74) Galatea.
" (62) Erato.	" (75) Daphne. (?)
1861. (63) Ausonia.	" (76) Freya.

*Comets.*—Comet III, 1861, telescopic, was discovered, Dec. 29, by Mr. Tuttle, at the observatory of Yale College. Encke's comet, on its return, was observed at the same place, Dec. 25, 1861, having at the time the appearance of a minute nebula; its perihelion was reached Feb. 6, 1862. Prof. Bond remarks of the comet that it was "for some time visible to the naked eye, and showed a respectable tail  $1^{\circ}$  in length." The appearances exhibited were similar to those of previous visits, the chief singularity being, as heretofore, that the coma first showed itself as a faint luminous projection toward the sun, the reverse of the direction in which its elongation usually occurs. Comet I, 1862, was discovered near  $\beta$  Cassiopeia, July 2, by M. Schmidt, of Athens, and on the same evening by M. Tempel, of Marseilles; its brightness that of a star of 4-5th magnitude; July 8, it was seen by Prof. Bond, of Cambridge. Its rapid apparent motion showed its nearness to the earth, from which, July 4, it was distant only 9,000,000 miles. This is probably the first astronomical discovery of any importance made within the last 2,000 years in that city in which the foundations of the science were laid. Comet II, 1862, was discovered July 18, by Mr. Thos. Simons, at the Dudley Observatory, and on the same evening by Mr. Tuttle, at Cambridge. It was nearest the earth—33,000,000 miles—Aug. 31; it remained five weeks within the circle of perpetual apparition, its nucleus 100,000 miles in diameter, tail nearly 18,000,000 miles in length, or longer than that of the great comet

of 1861; and but for the light of the moon, then in its first quarter, it would have been visible to the unaided eye. Comet III, 1862, is the second of two comets discovered by Dr. Bruhns, of Leipsic Observatory, on the nights of Nov. 30, and Dec. 1, respectively. This comet soon after ceased to be visible in the northern hemisphere, becoming visible in the southern, from which it was expected to return to the northern heavens in Jan. and Feb., 1863. The character of its orbit appears to differ from that of the orbits of all other known comets. The first of Dr. Bruhns' comets is to be styled I of 1863, since it passes its perihelion in February of this year. It was in December travelling toward the constellation Boötes, rising about 1 in the morning.

The brilliant and long-continued appearance of Donati's comet, in 1858, has led to a considerable extension of comet-literature. Among the latest and most valuable of the additions to this, is the "Account of the great comet of 1858, being vol. 8d of the *Annals of the Astronomical Observatory of Harvard College*;" by Prof. G. P. Bond, Director of the Observatory. The volume presents a more thorough discussion of the physical peculiarities of the comet referred to than has ever been published respecting any other, and is illustrated with 57 engravings in the best style, representing every aspect assumed by the comet during the period of its visibility, 275 days.

A new theory of comets is offered by Mr. Benjamin V. Marsh in the "American Journal of Science," for Jan. 1862, in a paper entitled, "The Distinguishing Features of Comets considered as Phases of an Electrical Discharge, resulting from Eccentricity of Orbit." \*In the same journal, May, 1861, the author had argued that an auroral streamer is due to a current of electricity originating in the upper part of the earth's atmosphere, and from it shooting off into space, the current carrying with it at nearly its own velocity material particles from the atmosphere, by rendering which luminous its own course becomes visible, and being thus seen (as he infers) throughout heights actually of 500 to 600 miles, through which extent the passage of the electricity itself is almost instantaneous. He now considers the question whether the coma or tail of comets may not be of like character. Either comets must be, in the material composing them, unlike the other bodies of our system; or else their peculiar features must result from some conditions to which they alone are exposed. But the number of the comets, and their coming from every direction and from all parts of space, would appear to show that the former supposition cannot be true,—that they must contain every variety of material constituting the bodies of our system. Now, excepting the difference of their appearance, the only other respect in which they differ from all others of those bodies, and in which they all agree among themselves, appears accordingly to be that in the form of their orbits. In

the different parts of its flight, every comet goes through changes of condition that contrast extremely: not so, however, with the planets. Halley's comet, at perihelion, is 56 millions of miles from the sun; at aphelion, 3,370 millions of miles. Hence, its greatest being more than 60 times its least distance, the solar light and heat received by it during a given time at perihelion is more than 3,600 times that received during a like period at aphelion. Again, while the comet is  $6\frac{1}{2}$  years in passing over one heliocentric degree of its orbit in aphelion, at perihelion it accomplishes the same distance in 15.7 hours. The comet, beginning to cool faster than it is warmed by heat received, from the time at which its distance from the sun first begins to increase, must, in view of the feeble heat received in all distant parts of its orbit, continue cooling until in its return it has already approached so near the sun that its velocity begins to be greatly accelerated. Now, along with this rapid approach toward the sun, there is an augmentation (in duplicate ratio) of the light and heat the nucleus or comet-mass receives; so that during the latter part of its return course, and within a relatively small part of the entire orbit, there occurs a violent transition from the lowest temperature at any time reached by the mass, to the highest. This change, the author infers, is likely to develop a powerful discharge and current of electricity, which will carry off from the substance of the nucleus myriads of extremely fine particles, as in certain circumstances such currents are known to do. That absolute smallness of the comet's perihelion distance does not explain the development of the luminous coma, is proved by such facts as that some bright comets approach the sun no nearer than about the distance of Mars or Jupiter. But from the view given, it follows that great splendor must result when, along with extreme eccentricity of path, there is combined a comparatively small perihelion distance; since in such cases the change of conditions during the approach will be correspondingly intensified. And that such combination of circumstances is attended with the development of extraordinary brightness, is shown by the facts, being remarkably exemplified in the instances of the comets of 1843 and 1861. The ratio of aphelion to perihelion distance for Polyhymnia, the most eccentric of known planetary bodies, is only 2; that of some telescopic comets given is from as low as 3.5 up to about 12; that of De Vico's comet, just visible, is 52; that of Donati's comet (1858) was 624; that of the great comet of 1843 was 18,873; and that of the comet of 1861, not less than 137,173. Of the two last named, the perihelion distance was also extremely small. Other consequences following from the theory are, that brilliant comets should have long periods, and that they should begin to appear bright at a great distance; and both these requirements are in accordance with observed facts. If the theory be true, and the forms of

the orbits of asteroids and comets could be exchanged, then, within a single set of revolutions, each of these kinds of bodies would have assumed the characters now peculiar to the other. According to the view presented, the substance of the cometary mass must slowly waste; and it is stated that Professors Pierce and Mitchell had already been led to suspect that to a progressive diminution of its mass might be due the known retardation of Encke's comet. It will be seen, however, that the theory of Mr. Marsh surrenders the idea of the planetary spaces as really vacuous, or free from a diffused ponderable matter. If the comets waste, as he supposes, then all space or many parts of space are filled with an actual atmosphere of extremely rarefied comet-matter; and the planets are very sure to meet with obstruction accordingly. Moreover, the view of the aurora involves a progressive exhaustion of our own atmosphere, against which some of the generations of a very remote future might desire the opportunity of entering a remonstrance.

*Nebulæ.*—Toward the close of the year 1861, Prof. D'Arrest, of Copenhagen, who has been for some time engaged in a revision and cataloguing of the nebulæ, announced that a nebula in the constellation Taurus, discovered by Mr. Hind in 1852, had totally vanished from its place in the heavens. By observations made about Jan. 26, 1862, Le Verrier confirmed this declaration; although by other authorities it has since been stated that the nebula, invisible to other telescopes, was still detected with the great refractor at Pultowa. This much is certain, that a nebula sufficiently bright to be readily seen, between 1852 and '58, through many telescopes in different countries, can now no longer be seen through most of those instruments, if through any of them. The place of this nebula was about  $1\frac{1}{2}$  degrees from  $\epsilon$  Tauri, in the group known as the Hyades. Its diameter was about  $1'$ ; and its light being more distinct toward the central portion, it had an appearance which indicated that, if ever resolved, it would prove to be a very remote globular cluster of stars. It was seen by Chacornac in 1854, while he was engaged in forming a chart of the stars in this region; and having also been missed by him during a subsequent search in 1858, it is now supposed that its disappearance probably occurred about 1856. From 1852 until the last named date, a star showing the 10th magnitude, and first noticed on the same night with the discovery of the nebula, almost touched the latter at its edge. From the circumstances of its discovery, Mr. Hind had suspected that this star was variable; and in fact, since the nebula has ceased to be visible, the star has dwindled to the 12th magnitude.

A second case of a variable or disappearing nebula, is that of one in the Pleiades, and  $4^\circ$  distant from the preceding, discovered by M. Tempel at Venice, Oct. 19, 1859, and which

was stated by him at the time to be quite large and in brightness equal to that of a beautiful telescopic comet. For this nebula M. D'Arrest looked repeatedly on clear nights in August, 1862, with his fine refractor, but saw no trace of it. M. Schmidt, of Athens, learning of the circumstance, announced (Sept. 20, 1862) that the nebula could not have become visible more than a very short time before the date of its discovery by Tempel, or that at least it must have been very faint for some time previous; as he had since 1841 made many and most careful observations of the stars in the Pleiades, estimating several hundred times their apparent magnitude; and he had not seen the nebula in question until Feb. 5, 1861, when it appeared large, pale, and of no definite form. After that date, he observed it several times, the last on March 26, 1862, when it was easily visible. M. Auwers suggests a doubt in regard to the variability of this nebula, thinking that its apparent disappearance may perhaps be accounted for by the greater ease with which faint, ill-defined objects are detected with small than with large telescopes.

A third instance of variability is that of a nebula not far from the two already named, observed at Bonn, and afterward at Cambridge, and which is now almost invisible. These being the only three nebulae whose variableness appears established, it is a curious fact that they are all situated in the same celestial region, in the vicinity of the Pleiades.

A few years since, the resolution, by aid of Lord Rosse's powerful telescope, of one or more of those singular, fixed, and hazily luminous patches in remote space into congeries of actually separated and individual stars, a resolution confirmed subsequently by other instruments and on other nebulae, proved sufficient to shake the "nebular hypothesis" of Laplace to its foundation; until certain physical explorers bethought themselves that Laplace's diffused or nebulous condition of primitive matter could still be a fact, as so many of the phenomena of our planetary system and of the geological constitution of the earth seemed to require, even though all the existing nebulae of the heavens should successively prove to be in reality clusters of stars. Now, however, assuming that the three nebulae referred to have actually disappeared or faded, new and strange questions are raised; and the facts seem likely to prove as irreconcilable with the doctrine that all nebulae are clusters, as the resolution of some of them was with the hypothesis of Laplace. Is such disappearance due to the interposition of some vast, dense, and invisible body, but which, not being wholly opaque, does not suffice to hide observed stars? Or, in the first of the cases above given, did the star illuminate the nebula, which in that case could not have been itself a cluster? and did the visibility of the nebula diminish with the decreased light of the star? Several variable stars have, in fact, been detected in the region

of the great nebula of Orion; and in 1860, a star suddenly shone out in the middle of the well-known nebula, Messier 80, in Scorpio, and vanished again in a few days. Up to the present time, however, the subject remains one of considerable mystery.

*Stars.*—Some facts relative to variable stars have necessarily appeared in the preceding section. The star which has become known as the "companion of Sirius," was discovered Jan. 31, 1862, by Mr. A. Clark, of Cambridge, Mass., with his new achromatic object-glass of 18½ inches aperture. Sirius being in our latitude low, and the new star being in contrast with its extreme brightness but faint, it is at first difficult to catch sight of the latter. It remains for the present a question, whether this forms with Sirius a binary star; and whether, accordingly, it is the hitherto invisible body which has disturbed the motions of Sirius, and the existence of which had been surmised by Bessel and Peters; as also whether it is merely an opaque body illuminated by the brighter star, or itself, though large, only feebly self-luminous. Mr. L. M. Rutherford, of New York, on the same evening on which he first learned of the discovery of the companion to Sirius (March 8), readily detected it with his equatorial telescope of 11½ inches aperture and 14 feet focal distance, the workmanship of Mr. Fitz, of the same place. Though admitting that the new star may be a variable one, he judges that the difficulty of seeing it most likely arises solely from its nearness to an object so bright as Sirius. He also finds in the facts of its discovery now given, a probable illustration of such a principle as that it requires a far higher telescopic power to make a new discovery than it does to redetect the same object when its existence has become known to the observer.

Just as, in 1851, Dr. Peters found that the irregularities in position of Sirius could be explained by motion of the bright star about an invisible one (since found), so recently M. Auwers finds that Procyon moves about a dark star, and in an orbit whose plane is that of the visible heavens, the distance of the companion being about 1½". He concludes that the mass of the dark body equals ¼ that of the sun, or at least 100 times that of Jupiter. Thus Bessel's idea of the existence of dark stars in the heavens, controlling the motions of some of those visible to the eye, an idea ridiculed by Humboldt, appears now to be established in one instance, if not in two.

*Refraction.*—Prof. Challis read before the meeting of the British Association, 1862, a paper on the "Augmentation of the Apparent Diameter of a Body, by its Atmospheric Refraction." For reasons which he gave in a previous discussion on the earth's atmosphere, he assumed that, generally, the atmospheres of the bodies possessing them have definite boundaries, at which their densities have very small but finite values. Two cases of refraction

present themselves: that of the earth's atmosphere, first, is one in which the curvature of the course of a ray passing through it is less than the curvature of the globe such atmosphere surrounds. The moon having, if any, an atmosphere rarer than that of the earth, the like result must, *a fortiori*, hold of any atmosphere it may have. As a practical consequence, the apparent diameter of the moon, as ascertained by measurement, will be greater than that inferred from observation of an occultation of a star; since, through bending of the light by the moon's atmosphere, the star will disappear and reappear when the line of vision is a little within the moon's apparent boundary. A like result would be obtained from a solar eclipse. The author stated that by actual comparison of the two kinds of determination, such an excess to the amount of 6" to 8" was found. This difference, accordingly, he considers as indicating a lunar atmosphere of very small extent and density. The reasoning leads us to anticipate that, in a solar eclipse, a slender band of the sun's disk, immediately contiguous to the moon's border, will appear somewhat brighter than parts more distant: attention to this feature at the next solar eclipse was advised. The other case, that in which the curvature of path of the ray is greater than that of the globe having the atmosphere, was assumed true in the instance of the sun. On this supposition, it was shown that all objects seen by rays coming from the sun's periphery, would by the great refraction be brought out apparently to the level of the boundary of the solar atmosphere; and this would be so, whether the rays proceeded from objects on the surface of the interior globe, or from cloud-like masses suspended in its atmosphere. The contour of the sun, accordingly, should appear quite continuous, and the angle of its apparent semidiameter will equal the angle subtended at the earth by the whole height of the solar atmosphere. For like reasons, the apparent diameter of the planets will be augmented to a certain amount by the effect of refraction; and on account of the great distances of these bodies from the earth, the eclipse of a satellite will take place as soon as the visual ray begins to be bent by interposition of the atmosphere of the planet.

**AURORAS.** The questions relative to the precise manner of production of the auroral display, and its elevation and place with respect to the earth, have been during the year 1862 somewhat pointedly discussed. The *aurora borealis* was, of course, known to the civilized world earlier than its counterpart of the southern polar regions; and the theories at first proposed to account for it, among them that which referred the light to the bending of the sun's rays by the atmosphere about the northern convexity of the earth, and that which supposed it to be the effect of rays reflected from icebergs, were either imperfect on physical, or impossible on mathematical grounds, or defec-

tive in both these particulars. Since the phenomena of electricity became better known, the view proposed by Cavendish, to the effect that the aurora is due to the passage of electricity through portions of the atmosphere in which the air is considerably rarefied, or at all events serves as a conductor, and yet not a perfect one, has become (so far as it extends) quite generally adopted. The causes and conditions leading to disturbance of the electric equilibrium and to the actual discharge, remained to be investigated. Many years since, it began to be observed that not only are the instruments at the earth's surface employed to indicate electric disturbance (electrometers) subject to excitation during the auroral displays, but also that at such times marked deviations or irregularities of the magnetic needle almost invariably occur. At times when the aurora has appeared simultaneously over a great extent, as in 1831, 1839, and 1859, the magnetic disturbance has been unusually great. It is now known also that generally the display occurs at the same times at both poles, or as *aurora borealis* and *australis*; though it is believed that, for some reason, the phenomenon is somewhat the more frequent in and near the arctic zone. Of controversial papers on the subject during the year, the most important have been that of Prof. A. De la Rive, read before the *Société de Physique et d'Histoire Naturelle*, of Geneva, Feb. 6, 1862, an abstract of which appears in the "Philosophical Magazine," vol. xxiii, p. 546; and that of Dr. David Walker, in the "Intellectual Observer," Nov. 1862. The chief addition to our physical knowledge of the subject is probably to be found in the "Ninth Article" upon electrical currents near the earth's surface, and their connection with the aurora, by Prof. E. Loomis, of Yale College,—*Amer. Journal of Science*," July, 1862.

Of course, no theory of the aurora can be correct, unless according with the fact of the actual position in space of the luminous arc or streamers: this being a point not easily determined, and probably not yet known, each theory must assume for the display some position to which its requirements will correspond. Cavendish supposed the height of the aurora about 71 miles,—the air, if there existing at all, having but  $\frac{1}{135,000}$ th part of its density at the earth; Halley, Dalton, and others assumed heights of 52 miles or upward. The actual height of the base of the visible arc should be ascertained by trigonometrical measurement from different positions at the same time; yet observers at different places must often see at the same moment each a different aurora; and in an instance of measurement by two observers and supposedly of the same aurora, Jan., 1831, one of these made the height 18 miles, the other not less than 96. Prof. Loomis, in his "Eighth Article" upon auroras, especially the great aurora of Aug. 28, to Sept. 4, 1859 (*"Amer. Jour. of Science,"* Nov. 1861), by comparing the angles of elevation of the same arches as seen from different positions, in a few in-



stances given, makes the lower limit of these at a height varying from 46 to 50 miles above the earth, the upper limit at heights of 495 to 534 miles. Many modern observers have, on the other hand, concluded that the luminous space is seldom higher than the clouds; and some, as Capt. Parry (1825), Sir Wm. Hooker, Gen. Sabine, and Dr. Walker (1859), relate the observing of auroras, parts of which they decided were very near the earth, in some of these instances the lower portion appearing to be visible (as in case of rainbows) between the observer and an elevated shore or ground at some distance. Dr. Walker observed the aurora in the arctic regions occurring repeatedly in the direction of open waters, from which evaporation was going on, and at times when the air showed minute spiculæ of snow, or was gradually filling with mist, or where cirrus clouds appeared in the sky. Biot proposed that the light occurred during the imperfect conduction of electricity between upper and lower atmospheric strata, by a sort of clouds of extremely subtle metallic particles, but of which it is very difficult to admit the existence; and Prof. Potter, of England, in the "Philos. Mag.," 1862, objecting to De la Rive's theory (yet to be named), and holding to the view of a great altitude, offers a hypothesis somewhat similar to the last, to the effect that the light is due to the electromagnetic influence of the earth on masses of very rare vapors, of a nature like that of meteorites or vaporous comets, moving under control of gravitation in the planetary spaces, and affected in the manner supposed only when nearly approximating to the earth. For a brief mention of Mr. Marsh's theory, which like the last two is cosmical rather than terrestrial in character, and of an objection to that theory, see *Comets*, under ASTRONOMICAL PHENOMENA, &c.

The experimental observations of Plücker, Gassiot, and others, had already shown considerable traits of resemblance between the behavior of the electric discharge in a partial vacuum, and under the influence of magnetism, and the appearance of the auroral light; and suggestions were offered by Faraday and Humboldt pointing in the same direction. Hansteen had generalized the fact that the luminous arc of the aurora is concentric with the earth's nearest magnetic pole—that point, for the strongest N. magnetic pole, now about lat. 60° N., long. 81° W., toward which the magnetic meridians converge,—in other words, that the arc stands at right angles to these meridians. It is doubtful whether the theory of the aurora proposed by Dr. Walker does full justice to some of the facts and principles now presented; although the author claims for it a close agreement with his own and other arctic observations of the phenomenon. He supposes that the cause of the electrical disturbance is the condensation and freezing of vapor, at any elevations at which these changes may take place, the result being an evolution of positive electri-

city [query: that carried up by the vapor from the evaporating surface?]; that the body of air so affected being surrounded by air which does not perfectly conduct, an inductive action takes place between it and more external bodies of air, as between the two coatings of a Leyden jar; but that the excess of positive electricity, where liberated, being in some degree transmitted from particle to particle of the air, renders the mass for the time luminous, the lower edge of the arch showing where the change in the vapor and in the electric equilibrium begins to take place. The luminous tracts or streamers, then, are portions of the air through which the opposite electricities are making their way, in the tendency to a restoring of the equilibrium. If true, the theory would appear to show why the aurora usually, if not invariably, appears in close connection with clouds, usually cirrus, or where at least the sky wears a hazy aspect. Hence, too, the aurora can be at any height at which the supposed conditions exist; and hence, it may be, the explanation of the more frequent appearance of auroras of late years, the winters having been in many instances unusually severe. The theory of M. De la Rive appears to be not only more clearly in harmony with the great general facts now known in relation to the aurora, but also to have been followed out to greater particularity of detail than those offered by other explorers; while the experimental illustration which he has been able—through use of an apparatus constructed under his direction by M. Eugène Schwerd, a German artist in the establishment of Prof. Thury—to produce, is remarkable for the complete and exact manner in which it imitates the actual phenomenon in nature. Although the germ of De la Rive's theory is conveyed in a letter of his to Arago in 1849, and a more complete development of it is given in his "Treatise on Electricity" (London, 1858), yet his communication of the year 1862 is important as giving the latest and fullest exposition, as well as the more perfect arrangement for experimental illustration, of the subject. The apparatus itself is of too complicated a nature to allow of description in detail in this place: a general, and it is hoped, intelligible account of both the theory and its illustration can be briefly given.

M. De la Rive sets out with two principles which he regards as definitively established; 1, that generally northern and southern auroras coexist—a fact which the series of observations made at Hobart Town in the southern, and Christiania in the northern latitudes particularly confirm; 2, that the aurora is always an atmospheric phenomenon. In confirmation of the latter view he cites particularly the opinions of Arago and Secchi. In reference to the source of the electrical charge: the waters of the ocean being at the surface continually in a positively electrified condition, the vapors arising from them conduct this electricity to the upper strata of the atmosphere; and being then in a considerable degree carried by the upper trade

winds (or anti-trades) toward the polar regions, they form in those regions a sort of positive envelope to the earth, the surface of which is itself usually or always negative. Now the earth being an almost perfect conductor, and the highly rarefied air of the upper regions being also such, while the lower atmosphere is less conductive or highly non-conducting, the result is an arrangement that precisely and on a very grand scale represents the two coatings and intervening insulating layer of the electrical jar or the condenser. The antagonistic electricities most strongly intensify each other where their positions approach the nearest, and this, though not always, will be in a general way near to the two poles; in such positions, when their intensities have passed a limit depending on the insulating power of the lower air, more or less frequent discharges will occur: these discharges, taking place in the lower latitudes and in summer more frequently in form of lightning, will, through difference of meteorological conditions, in the higher latitudes and in winter more frequently appear as displays of auroral light. While, through high conducting power of the earth, the auroral discharge must usually take place almost or quite simultaneously at the two poles, there can evidently exist such differences in the charge at the two poles, in the condition of the intervening air, and otherwise, as shall produce not only differences in the display from moment to moment in either hemisphere, but also inequalities of time and brilliancy in the two, or the appearance of the light at only one of the poles. Owing, moreover, to the low conducting power of the medium, the neutralizing of the opposite electricities cannot be instantaneous, but must be by successive and more or less continuous discharges.

The magnetic phenomena in our hemisphere attending the aurora consist in an augmentation of the westerly deflection, with often more or less oscillation, followed and occasionally preceded by a feebler easterly deflection. Among the observed electrical phenomena are currents, frequently very intense, in lines of telegraphic wire. The observations of Dr. Walker in England, and of Prof. Loomis in America, have shown that during the appearance of an aurora these currents vary every moment, and that in direction as well as intensity, flowing more generally from N. to S., but being at irregular intervals reversed. These variations are in part to be ascribed to the location and relative intensity of the discharges; these taking place at both poles or chiefly at the north pole, the current along the earth will, in the northern hemisphere, flow southward; and the well-known electro-magnetic effect in all such cases will be to produce westerly deflection of the needle. But when the only or stronger discharge is at the south pole, the current in the earth will move northward; and those familiar with the character and production of induced currents will see that the plates at the end of the telegraph wires becoming, when charged

in either direction, rapidly polarized by the current which they transmit, speedily give rise to an induced current, moving in the opposite direction, which will suffice either to diminish or momentarily replace the original one: through such electrical variations, the oscillations and occasional easterly deflection of the needle are to be explained.

Essentially M. De la Rive's apparatus for reproducing in miniature the auroral display, and showing the fact and influence of the attendant circumstances now considered, consists of a wooden sphere of about 12 inches diameter, to represent the earth, supported at the ends of its horizontal axis by upright soft-iron rods, the magnetic poles being represented by two cylindrical soft-iron rods, at the ends of the axis, projecting each about 2 inches beyond the supports, insulated at all parts save the free ends, and which can be rendered magnetic by action of coils or of the poles of an electro-magnet, when desired, while the principal portion of the length of each outside the body of the sphere is situated within and in the middle line of a glass tube of larger diameter (about 4 inches), and greater length; these tubes being hermetically closed at the two ends with metallic disks, as well as furnished with stop-cocks through which the air within them can be exhausted to any rarity desired. It is within these partially vacuous tubes that the miniature auroras are to be produced. Through the inner metal disk of each, of course, the soft iron (magnetic) pole projects, terminating about mid-length of the tube; immediately about and concentric with each of these poles, is a soft-iron ring, of such size that it lies just within the glass tube, and leaves an annular space between itself and the pole: the ring plays the part of the upper electrified air; the intervening space, that of the stratum in which the discharge becomes visible. To obtain the effect of the earth's conduction between the poles, a band of blotting paper is extended from one of the soft-iron poles to the other; while a similar band is extended equatorially about the sphere; and during experiments both these are kept moist by capillary action from a little capsule containing salt water. On the opposite sides of the equator of the sphere, small copper plates are fixed to the wood upon the meridian conducting band of paper, and wires proceed from these to the coil of a galvanometer needle about 36 feet distant, so as to be beyond the influence of the magnetic action upon the poles of the sphere. The electrical current used is that of a Ruhmkorff's coil, one pole of which, through the conducting paper bands, is made to communicate with the soft-iron poles of the sphere, while the other divides into two branches, and by wires passing through the outer disks of the glass tubes, terminates in the two rings. Having the tubes properly exhausted, let the positive pole of the electrical apparatus communicate with and terminate in the poles of the sphere, while the negative termi-

nates in the rings: then, sometimes at one pole of the sphere, usually at both, a luminous jet from the pole to the surrounding ring appears. Let the poles of the sphere be now at the same time magnetized: the jet at once spreads around the ends of the soft-iron poles, very soon forming two distinct colored rings, concentric with it and between it and the iron ring—the inner of a rose-red, the outer violet—with a dark annular space between; and both these rings rotate around the pole. But the course of the current is thus far the reverse of that in the natural phenomenon. Now let the positive pole of the electrical apparatus be the rings, and the negative be the two soft-iron poles of the sphere—the air in this experiment requiring to be somewhat more dense than before:—the conditions then represent those in nature. Having obtained the jet of light showing passage of the current, again magnetize the poles of the sphere, and at once the jet again begins to spread out and rotate; but it now invariably extends itself laterally by throwing off a multitude of minute brilliant jets (the auroral streamers), which extend like the spokes of a wheel from the poles toward the rings, and turn with greater or less rapidity. Here, then, is an extremely faithful reproduction of the aurora; and it is particularly worthy of notice that this appearance is only to be obtained when the positive current flows from the rings toward the poles of the sphere; and that, however apparently identical the arrangement and conditions of the two poles of the sphere, the discharge will still through slight and inexplicable changes of condition, but in exact imitation of the natural phenomenon, begin at one pole first on one occasion, and again at the other, or during its progress will suddenly cease at one pole, or fly from one to the other. The phenomena of the current in the meridian conducting band, at least so far as the principal deflection of the needle is concerned, are illustrated by passing the same current as that in the apparatus through a surface of mercury over which a delicate needle is suspended, or by the galvanometer; though in these experiments the secondary induced currents and their effects do not come in.

In the communication of Prof. Loomis, above first referred to, he calls attention to the fact of his having shown, in his eighth article in the same journal, the existence of a stream of electricity drifting across Central Europe in a direction from about N. 28° E. to S. 28° W. After collecting during several months materials drawn from observations on the magnetic needle made at Toronto, Cambridge, and Philadelphia, from May, 1840, to Dec. 1842, and during a portion of this time at Washington also, he is led by a comparison of the times of the daily maximum and minimum deviations of the needle at the places named, to conclude that the maximum deviation of the needle advances like a wave over the earth's surface—the direction of its motion being from N. 68°

E. to S. 68° W. The observations, secondly, of the minimum deviation of the needle indicate a wave from N. 69° E. to S. 69° W. In view of their close approximation, he assumes the former as the true direction. The average of the velocities of the two waves, as deduced from comparison of the Cambridge and Toronto observations, is 184 miles per minute; by the Philadelphia and Toronto observations, 89 miles per minute. Comparing the observations, further, with the notices (often nearly or quite simultaneous) of occurrence of auroral displays, the conclusion is that for the eastern part of the United States the irregular deflections of the needle, whether attended or not with auroras, are as the rule propagated in the direction already stated, and with an average velocity of 112 miles per minute. A summary and comparison of notices—from 1820 to 1850—indicating the fact and direction of lateral displacement of the auroral beams, shows 86 cases of movement of the arches or beams from N. to S., only three in which it was from S. to N., and a few instances of change from one course to the other; also, 31 cases of movement from E. to W., and 15 from W. to E. Taking into account the effect of apparent motion, in parts lateral to the observer, the general conclusions are, that the actual motion of the streamers is from about N. N. E. to S. S. W.; and hence, that there is a general correspondence between the direction of the electric currents which traverse the earth's surface during displays of aurora and that of the movement of the auroral beams—the former, in the United States, being from about N. 68° E. to S. 68° W., the latter, from about N. 30° E. to S. 30° W.

A remarkable aurora visible in the region of the city of New York, at very near the hour of 12 on the night of August 4, 1862, was observed for a short time by the writer of this article. No notice of the phenomenon, save that of a daily newspaper, having been met with, the commencement and duration of the display cannot be given. In this aurora, the light was—at least in most parts of the heavens covered by it—not that of a somewhat fixed arch; on the contrary, it appeared and disappeared over considerable portions of the entire northwestern and northern sky in a rapid succession of almost instantaneous pulses or flashes, comparable in this respect to the appearance of very quickly moving puffs of steam, but of a pale reddish color. The general direction of the waves of light appeared to be from N. N. W., and they reached quite to the zenith. It soon became evident, on carefully observing the light, that the successive flashes continued to become visible and to disappear over nearly or precisely the same patches of sky. Such, it can readily be imagined, would be the case with electric discharges passing through successive bodies of air of differing conductive power; at all events, it appears difficult to reconcile the actual and peculiar character of such an aurora with any theory of its existing

above the limits of the earth's atmosphere. It would seem that auroras of this sort are but rarely observed: the notices at Christiania, Norway, 1842-'7, include those of four auroras "with flames," or "flaming:" one of these, Sept. 22, 1846, is described as showing "vehement flames over three fourths of the heavens; (color) reddish."

AUSTRIA. Emperor Francis Joseph I, born August 18, 1820, ascended the throne, Dec. 2, 1848, married April 24, 1854, to Elizabeth Mary Eugenia, daughter of Maximilian, duke of Bavaria, heir to the throne: Archduke Rodolphus Francis Charles Joseph, born August 21, 1858.

The most interesting portion of the history of Austria during the year 1862 consists in the proceedings of the *Reichsrath* (parliament). The Government made the utmost efforts to induce all the crownlands to send deputies, and thus to complete the organization and centralization of the empire. The number of deputies apportioned to every crownland was as follows: Hungary 85, Bohemia 64, Venetia 20, Dalmatia 5, Croatia and Slavonia 9, Galicia 38, Lower Austria 18, Upper Austria 10, Salzburg 3, Styria 13, Carinthia 5, Carniola 6, Bukowina 5, Transylvania 26, Moravia 22, Silesia 6, the Tyrol and Vorarlberg 12, Istria, Goerz, Gradisea, and Trieste, together 6. But the efforts of the Government were in vain. Hungary and its dependencies, as well as Venetia, persisted in refusing to take part in the proceedings of the Reichsrath, and of the 343 members of which it was to consist, no more than 200 were at any time present.

The Reichsrath contained two great political parties; one in support of the constitution of Feb. 26, 1861, and in favor of consolidating all the crownlands, in accordance with the constitution into one constitutional monarchy; the other, opposing the centralization of the empire, and the completion of the design of the constitution, as endangering the rights of those who were not of the German races. The majority being centralists consisted of the deputies of the German provinces, as Upper and Lower Austria, Salzburg, the Tyrol, Styria, and of several other provinces, where the population contains a strong element which is not German, but where the Government has succeeded in securing the election of partisans. Among the deputies who were not German it was in particular the Ruthenes of Galicia, under the leadership of Bishop Litvinovitch, who supported this party, out of opposition to the Poles, who inhabit the same country, and whose political influence they wished to break. The majority, in general, was favorable to liberal reforms. Its chiefs were Dr. Hein, of Silesia, recently appointed Minister of Justice, Gizkra, of Moravia, who was, in 1848, a prominent member of the parliament of Frankfort, Kuranda, editor of one of the leading dailies of Vienna (the *Oest Deutsche Post*), and Brinz, professor of Prague. The opposition to the centralization of the em-

pire (the Federalists), is headed by the Czechi, of Bohemia, who repel with indignation any idea of submission or conversion to the German element of the empire, and of the Poles, who still hope for the restoration of an independent kingdom of Poland. A small contingent of this party, which altogether counted about 50 members, was furnished by the Slavic population of Moravia, Carinthia, and Carniola. The leaders of the party were Rieger, Klaudi, and Brauner, of Bohemia, and Smolka, of Galicia. A small aristocratic body, headed by the Count Clam-Martinitz, generally voted with this party. The Chamber of Peers was, on the whole, less liberal than the Chamber of Deputies. A conflict between the two broke out, particularly on the question of the budget and of the privileges to be exercised in matters of taxation by the Chamber of Deputies. The upper house, however, on December 15, adopted the budget as voted by the Chamber of Deputies. On December 18, the session of the Council of the Empire was closed by a speech of the emperor, who expressed satisfaction that the confidence he had placed in the nation, by granting the constitutions of October 20 and February 26, had been justified. The emperor said: "Our resolute progress in the path of peace has powerfully increased confidence in Austria's strength, and has gained her the sympathy of other nations. The Reichsrath has proceeded firmly upon the solution of its task, and has already passed important measures. Basing the regulation of the budget upon the principle that the resources of the country itself must supply its necessities, I am convinced that such a result will be brought about by an equal division of burdens. Commerce has already shown increased animation in consequence of the abolition of the transit dues. The bill regulating the control of the Reichsrath over the national debt secures also the coöperation of the Legislature in supervising the expenditure. The new Bank Act has established the relative position of that institution to the State. The retrenchment of the expenditure has exercised a favorable influence upon the state of public affairs."

It has been generally acknowledged in Europe, and particularly by the English press of all parties, that Austria, during the year 1862, has made great progress in the path of constitutional freedom. On May 1 a law was promulgated, establishing the responsibility of the ministry. In December, two other important laws were published relative to individual liberty, and the inviolability of the domicile. These laws, although still imperfect, are substantially based upon what is known in England and America as the *Habeas Corpus* Act.

The efforts of the Government to overcome the discontent of Hungary and Venetia were unceasing, although not attended by any marked success. Count Forgach was sent by the Government to Hungary, in order to make himself acquainted with the real state of things.

What the Hungarian party chiefly insisted upon was the reestablishment of the comitats or municipal councils of Hungary, as the natural precursors of a diet, which they said might be constituted without the slightest danger to the monarchy. Count Forgach admitted the desirability of reestablishing the comitats, but doubted whether the time was yet come for such an experiment. He recommended his Hungarian countrymen to persevere in their conciliatory views, and that he should be happy to make himself their mediator with the emperor. Toward the close of the year 1862 it was thought that the basis of a compromise was agreed upon, and the leaders of the liberal-conservative party in Hungary, anxious both for the independence of their country and for its "indissoluble and indivisible" union with the other hereditary provinces of Austria, were said to be engaged in a negotiation with influential men in Vienna for that object. In November the emperor granted an amnesty to political offenders condemned by courts martial, as well as such refugees as had already returned to Hun-

gary. The emperor also ordered the total cessation of judicial proceedings pending for offences of a political character. For Venetia a new plan of organization has been drafted, according to which there is to be a diet composed of fifty members, chosen by direct election, who appoint their own president, subject to the ratification of the emperor. The executive power is to be composed of thirteen members, nine of whom are to be chosen by the diet, and four by the Government. The diet is to have the right to revise the plan.

The diets of the following provinces: Bohemia, Dalmatia, Galicia, Upper and Lower Austria, Salzburg, Silesia, Styria, Carinthia, Carniola, Bukowina, Moravia, Tyrol, Vorarlberg, and Istria, were convoked by an imperial decree for December 10. The Government wished to circumscribe their deliberations within narrow limits, but it was soon found impossible to evade the discussion of political questions.

The following table gives a complete exhibit of the different nationalities in Austria, according to the census of 1857:

CROWNLANDS.	Germans.	Northern Slavi.	Southern Slavi.	West Rumanians.	East Rumanians.	Magyars.	Other races.
Austria below the Enns.....	1,841,770	12,270	6,870	....	....	....	3,780
Austria above the Enns.....	683,990	....	....	....	....	....	4
Salzburg.....	140,197	....	....	....	....	....	....
Styria.....	640,806	....	869,246	....	....	....	24
Carinthia.....	281,558	....	92,767	....	....	....	....
Carniola.....	29,788	....	437,058	....	600	....	....
Goetz, Gradiska, Istria, Trieste, Tyrol and Vorarlberg.....	8,150	....	881,042	162,326	2,900	....	4,118
Bohemia.....	523,093	....	....	389,918	....	....	543
Moravia.....	1,764,373	2,925,982	....	....	....	....	86,389
Silesia.....	483,518	1,851,983	1,000	....	....	....	41,529
Galicia.....	284,848	223,923	....	....	....	....	8,290
Bukowina.....	114,293	4,067,107	....	....	....	....	451,466
Dalmatia.....	87,355	194,608	....	....	175,679	7,400	81,536
Lombardy and Venetia.....	19,250	....	869,810	45,000	....	....	1,313
Hungary.....	1,291,714	2,067,317	26,892	2,408,010	....	....	6,538
Croatia and Slavonia.....	24,470	6,500	593,625	....	1,171,676	4,888,987	454,948
Transylvania.....	200,364	1,768	811,757	487	50	12,770	6,783
	83,400	9,890	685,377	400	1,104,822	517,577	102,312
	150,200	218,000	77,000	83,000	47,500	70,500	18,645
<b>Total.....</b>	<b>7,889,925</b>	<b>11,044,872</b>	<b>3,962,774</b>	<b>2,989,136</b>	<b>2,642,958</b>	<b>4,947,134</b>	<b>1,217,589</b>

Among the Northern Slavi are included 6,132,-742 Chechi, Moravians, and Slovacks, 2,159,-648 Poles, and 2,752,492 Ruthenes. Among the Southern Slavi are included 1,183,533 Slovenians, 1,337,010 Croats, 1,438,201 Serbians, and 24,030 Bulgarians. Among the West Romanians are included 2,557,913 Italians, 416,725 Friulians, and 14,498 Ladinians. Among the other races are 3,175 Albanians, 2,255 Greeks and Zinzari, 16,131 Armenians, 146,100 Gipsies, and 1,049,871 Jews.

The population of the principal cities is as follows: Vienna, in 1857, 476,224, in 1861 about 512,000; Prague (in 1851) 142,588, Pesth 181,705, Venice 118,172, Trieste 104,707, Lemberg 70,384, Gratz 63,176, Szegedin 62,700, Verona 59,169, Brunn 58,809, Buda 55,240.

The total imports of 1861 consisted of 240,-732,288 guilders; total exports of 815,177,981 guilders. The merchant marine in the same year numbered 9,808 vessels, with 341,972 tons.

The financial condition of the empire will

appear from the following extracts from the Finance Law and the Budget for 1863, which have been published in the official collection of laws, where they fill together 29 columns. The Finance Law is in substance as follows: The total expenditure for the year 1863 is estimated at 367,087,748 florins. The total revenue 304,585,094 fl. The deficit of 62,502,654 fl. is to be covered by means of an augmentation of the taxes, by the sale of bonds belonging to the English loans of 1859, and of shares in the lottery loan of 1860. Should the deficit not be entirely covered, the Minister of Finances is empowered to raise a loan of 12,000,000 fl. If an arrangement with the National and Credit Bank should not be brought about, the minister shall be at liberty to raise another loan of 30,000,000 fl.

The following are the prominent features of the budget for 1863: the civil list is 7,458,-700 fl. (it was 6,127,200 fl. in 1862). The outlay for the Reichsrath, 726,537 fl.; Cabinet of the Emperor, 76,000 fl. (it was 72,900 fl. in

1862); Council of State, 151,837 fl. (it was 142,630 fl. in 1862); Ministry of Foreign Affairs, 2,486,150 fl. (it was 2,644,382 fl. in 1862); Ministry of State, 25,727,580 fl.; Ministry for Ecclesiastical Affairs and Public Education, 4,724,500 fl.; the Hungarian, Transylvanian, and Croatian Chancelleries, 18,572,185 fl.; the Ministry of Finance, 21,584,766 fl. (in 1862 it was 22,150,008 fl.); the Ministry of Justice, 9,150,567 fl.; the Ministry of Police, 2,645,676 fl.; the Ministry of Commerce, 4,618,142 fl. (in 1862 its expenses were no more than 383,400 fl.); other branches of the Administration, 1,386,200 fl.; Ministry of War, 107,023,000 fl.; to this sum must be added 5,777,000 fl., which is the "special revenue" (*eigenes Einkommen*) of the Military Administration; Naval Department, 10,481,619 fl. (in 1862 it was 13,165,900 fl.); subventions and guarantees of interest to private companies, 4,843,050 fl.; interest on the national debt, 118,698,750 fl.; State debts to be paid (*Schuldentilgung*) 18,870,500 fl. (these debts are specified); sums to be expended for State railways and telegraphs, and for subsidies to the fund for the emancipation of the soil, 5,061,961 fl.; loss on bills and coin, 7,118,420 fl.

The receipts for the same year were estimated as follows: Direct Taxes.—Land-tax, 62,481,900 fl.; tax on buildings, 19,261,800 fl.; trade tax, 5,814,900 fl.; *personal steuer* (poll tax), 5,271,000 fl.; legacy tax, 29,500 fl.; income tax on all kinds of property, with the exception of land and buildings, 15,157,700 fl.; direct taxes levied in the military frontiers, 1,799,100 fl. (this tax is paid by men who are obliged to render military service as long as they are able to shoulder a

musket). Indirect Taxes.—Excise of consumption, 57,678,700 fl.; customs, 15,247,515 fl.; salt, 33,059,600 fl.; tobacco, 30,901,470 fl.; stamp duty, 13,116,519 fl.; taxes and dues on legal affairs and on legal acquisitions, 21,271,639 fl.; lotteries, 6,084,400 fl. post office, 3,714,200 fl.; tolls, 2,928,609 fl.; stamping metals, measures, &c., 66,500 fl.; dues levied in the Lombardo-Venetian kingdom, 106,010 fl.; indirect taxes levied in the military frontiers, 155,564 fl.; revenue from State domains, mines, &c., 7,615,157 fl.; other receipts, 2,874,520 fl.

Austria has a very large public debt, which on Oct. 31, 1862, was made up of the following items:

Old consolidated debt.....	66,387,696 florins.*
New consolidated debt.....	1,992,812,170 "
Floating debt.....	419,777,168 "
Lombardo-Venetian debt....	70,713,807 "

Grand total..... 2,589,090,836 florins.

The standing army consists of 162,218 infantry, 40,344 cavalry, and 46,018 other troops,—total, 248,680; in time of war, of 442,000 infantry, of 52,760 cavalry, and of 92,935 other troops—total, 587,695. The highest military officers are, 3 fieldmarshals, 15 generals of the cavalry and field *zeugmeister*, 77 lieutenant fieldmarshals, and 120 major-generals in active service, and 31 generals of the cavalry and field *zeugmeisters*, 131 lieutenant-fieldmarshals, and 175 major-generals not in active service.

The navy, in May, 1862, consisted of 64 steamers, with 11,981 horse power and 647 guns, and 51 sailing vessels, with 840 guns.

The religious statistics, according to an official census, taken in 1857, were as follows:

Provinces.	Catholics.			Non-United		Evangelical.		Unitarians.	Israelites.	Other Relig. ionists.
	Latin.	Greek.	Armenian.	Greeks.	Armenians.	Confession of Augsburg (Lutherans).	Helvetic Confession (Reformed).			
Austria (Upper).....	1,350,684	78	85	1,170	466	8,645	1,495	20	6,999	57
Austria (Lower).....	678,404	1	..	2	..	14,928	56	1	4	..
Salzburg.....	140,182	..	..	..	..	58	7	..	..	..
Styria.....	1,004,919	3	1	18	19	4,977	185	1	6	2
Carinthia.....	307,642	8	..	1	..	16,668	18	..	..	..
Carniola.....	466,768	978	..	294	..	75	25	..	..	1
Littoral.....	502,729	118	28	856	22	820	188	1	3,718	1
Tyrol and Vorarlberg.....	564,889	..	..	..	..	74	41	1	548	..
Bohemia.....	4,601,385	15	3	14	28	34,189	56,797	22	86,539	6
Moravia.....	1,784,598	28	..	6	4	17,188	34,677	9	41,529	..
Silesia.....	396,548	3	1	1	4	61,373	45	1	3,230	1
Galicia.....	2,072,683	2,077,119	2,309	158	96	26,960	6,140	95	448,978	398
Bukowina.....	42,726	9,118	989	352,079	1,324	7,982	751	..	29,187	2,389
Dalmatia.....	387,900	341	..	77,189	5	17	8	..	318	..
Venetia.....	2,446,978	80	1	90	8	81	55	18	6,428	11
Hungary.....	5,139,018	837,311	491	1,105,969	719	796,980	1,556,368	964	398,105	97
Croatia and Slavonia.....	720,598	1,837	17	129,720	17	885	4,425	81	5,041	..
Transylvania.....	328,095	546,518	5,431	622,780	275	195,861	265,976	48,040	14,152	..
Military Frontier.....	448,708	5,588	2	537,269	19	15,564	4,274	4	404	..
Army.....	488,912	58,695	324	40,670	510	14,411	87,359	1,667	9,350	447
<b>Total.....</b>	<b>23,968,696</b>	<b>3,526,952</b>	<b>9,737</b>	<b>2,918,126</b>	<b>8,518</b>	<b>1,218,881</b>	<b>1,936,785</b>	<b>50,870</b>	<b>1,049,871</b>	<b>3,955</b>

\* A florin is 50 cents in American money.

## B

**BALLOONING.** The recent practical applications of this art are important. The success of Montgolfier in sending up in 1782 a balloon of large size, and having a surplus lifting power of 500 lbs., confirmed as it was the next year (and now just 80 years since), by the first aerial voyage—that of M. Pilatre des Roziers and the Marquis D'Arlandes—promised to mankind the mastery of a new field and element, and gave them in a manner a new sense of freedom. Important practical uses of the novel art were almost immediately suggested. Thus far, however, the attempts to realize these have not been in any case so persevered in as to result in an entirely successful working system. In fact, the conditions and contingencies the aeronaut may have to encounter are not yet fully known, and no means have been devised for determining the course as well as the elevation of the balloon; so that some amount of uncertainty and risk still attends the practice.

Three highly important uses of ballooning have been attempted, and in the order of time here given; namely: reconnoissance in war, scientific exploration, and communication in the way of travel or conveying intelligence between distant points. Of these purposes, the first has been exemplified in the history of the past two years; and the second of them particularly within the year 1862. The French republic early instituted a secret school of aërostation, with a view to the use of balloons in war. It is stated that at the battle of Fleurus, June 26, 1794, observations of the Austrian camp were in this way made, and that by the signals conveyed to him Gen. Jourdan was materially assisted in winning the victory of that day; as also, that Napoleon had a balloon sent with his army in the campaign in Egypt. The remarkable ascents for scientific purposes in the early part of the century, beginning with that of MM. Gay-Lussac and Biot in 1804, are well known. To test the question, then already agitated, and growing out of the theory of the trade winds, as to whether there is at heights of about 2 to 4 miles in the atmosphere a quite constant wind moving (in the northern hemisphere) to N. E., or generally speaking, from westward to eastward, the aeronaut Green, in Nov. 1836, rose from London and actually sailed to Weilburg in Germany; distance 500 miles, time 18 hours. In Sept. 1849, M. Auban sailed from Marseilles to Turin, crossing the Alps, 400 miles in 8 hours. Napoleon III, in his campaign in Italy, summoned to his aid the aeronaut M. Goddard; and by his reconnoissances prior to the battle of Solferino important information respecting the disposition of the Austrian army was furnished. For such reconnoissance the balloon is, so to say, tethered by a strong rope, being al-

lowed to ascend to heights of a few hundred or a thousand feet, as may be necessary, and at will drawn down again. From its elevation a greatly enlarged field of view is secured, upon which rivers, forests, towns, fortifications, armies, &c., appear in a sort of perspective, in reduced but relatively true proportions, as if plotted or laid down on a chart. M. Nadar was at a later date directed to experiment in taking photographs of the field of view from a balloon over Paris, in order to call in photography also to the aid of military reconnoissance. In the United States, about the year 1860, very clear and satisfactory photographs of the earth's surface, as presented to the point of view of a balloon elevated many hundred feet in the air, were taken by Mr. J. W. Black, of Boston. Mr. John Wise, of Lancaster, Penn., having from 1835 to July, 1859, made 230 ascensions, was led by his experience of upper eastwardly currents to revive the project of travelling by means of these. Two of the journeys undertaken in consequence form memorable and well known events in the history of the last-named year; the first, that of Wise, with Mr. John La Mountain and two others, July 1, 1859, from St. Louis, Mo., to the town of Henderson, Jefferson county, N. Y., 1,150 miles in 19 h. 50 m., or at an average of nearly a mile per minute; the second, that of La Mountain and Mr. John A. Haddock, Sept. 22, 1859, from Watertown, N. Y., and the greater distance after nightfall, to a point in the great Canadian wilderness 150 miles N. of Ottawa city, and almost due N. from the place of setting out, a voyage of 800 miles in about 4 hours.

In the existing war between the Government of the United States and the Southern Confederacy, balloon reconnoissances under charge of Messrs. La Mountain and T. S. O. Lowe, and perhaps others, have been to some extent availed of. In an ascent over Washington, June 18, 1861, Mr. Lowe achieved for the first time the feat of telegraphing from an aerial station, in this case at an elevation of about 600 ft. This was accomplished by looping with a telegraph wire contiguous to the place fine and flexible helix wires several hundred feet in length, and paying these out from a reel at the same rate with the rope releasing the balloon, the helix wires connecting within the latter with an operating instrument, so that the balloonist, making use of the current of the land wire—now turned out of its course to his movable station—transmitted intelligence as from any other station to the next on the line, and which was in this case the office in the city of Washington. The following is a copy of this first despatch, transmitted through the War Department:

BALLOON ENTERPRISE, June 18, 1861.

*To the President of the United States:*

From this point of observation, the city, with its girdle of encampments, presents a superb scene. I have pleasure in sending you the first despatch ever telegraphed from an aerial station, and in acknowledging indebtedness to your encouragement for the opportunity of demonstrating the availability of the science of aeronautics in the military service of the country.

T. S. C. LOWE.

Mr. Lowe not long afterward made reconnoissances in the vicinity of Fairfax Court House. Aug. 10 of the same year, Mr. La Mountain successfully observed the position of the enemy's forces beyond Newport News and on Sewall's Point, by ascending from the deck of the tugboat *Adriatic*, anchored in Hampton Roads, and to the unusual height of 8,000 ft. Oct. 4, having ascended from the camp of the Union army on the Potomac, and reconnoitred, he then severed the cord holding the balloon, and rising to the height of  $1\frac{1}{2}$  miles was carried directly over the enemy's lines, making a still more satisfactory observation of their position; then discharging ballast, he rose to 3 miles, and at this elevation passed over Washington, descending finally within the State of Maryland. In the peninsular campaign under Gen. McClellan, balloons were employed as a regular part of the system of reconnoissance. A letter from Mr. Parker Spring, superintendent of the telegraph construction in the army, contains an account of the use of the telegraph in connection with a balloon during the battle of Seven Pines. He states that when the battle was at its height Mr. Lowe and himself, having established communication with the wire to Fortress Monroe, 100 miles distant, ascended to a height of 2,000 ft. Mr. Lowe took observations through a good telescope, reporting to Spring, who at once telegraphed the information of the enemy's position and movements thus acquired to the commanding officers, through aid of an operator and recording instrument at the point beneath. The aeronauts kept up their observations until dark of Saturday, pointing out the position of the batteries, &c. On Sunday morning they ascended again at daybreak, and about noon were able to announce the commencement of the enemy's retreat toward Richmond. The streets of Richmond, as seen in the early part of the day, appeared nearly deserted; after the retreat had set in multitudes of ambulances, carts, &c., were seen conveying the dead and wounded along the road to Richmond; and about twilight the innumerable camp fires lighted, and the smoke from the hospitals and barracks, showed that the main body of the army had fallen back to the city.

At the meeting in 1861 of the British Association for the Advancement of Science, a committee was appointed to superintend a series of balloon ascents for scientific purposes, the sum of £200 being applied for expenses. Mr. Coxwell, an experienced aeronaut, being enlisted in the matter, constructed a balloon of

larger dimensions than any before seen in England—height 69 ft., diameter 54 ft.; composed of 46 gores, each 44 inches at greatest width; with a total capacity equal to 95,000 cubic feet. A previous trial with an old balloon and the first trial with the new one also having failed, eight successful ascents were afterward made during the months of July, August, and September; and these have possessed considerable interest in scientific and other points of view. The committee at the last meeting at Cambridge, 1862, report a total expenditure for these ascents of 329,000 feet of gas, 115,000 feet being wasted; whole outlay £270; and they recommend a continuance of the experiment, at other seasons of the year, and a further appropriation to that end.

In these ascents, Mr. James Glaisher performed the office of philosophical observer, Mr. Coxwell being engaged as the practical balloonist. Mr. Glaisher read before the Association at its last meeting a paper giving a summary of observations made and of facts connected with the experiments. He first called attention to the circumstance that all experimental investigations carried on at and near the surface of the earth are in many ways subject to disturbance, from the influence of the latter as a physical body; among the disturbing agencies, being heat, as radiated by the earth, or conducted by or reflected from it; reflection of light; currents of air; effect of evaporation from neighboring bodies of water, or of condensation on other bodies, &c. From such influences we do not escape even by going to the tops of mountains; but to the greatest extent practicable, only in a balloon at considerable height. Is it then possible to make delicate and accurate observations in a balloon at great height? Can the observer there be at his ease so as to observe as well as on the earth? Can he make the observations with tolerable safety to himself? If these questions are practically answered in the affirmative, very important gains should accrue to the sciences of meteorology and astronomy, especially in the latter science in connection with our knowledge of the refraction of light by our atmosphere, and its effect on the apparent places of the stars—a point so essential to navigation; while it was probable that valuable results would also be attained in respect to magnetism, chemistry, &c. A greater familiarity moreover with the changing conditions of the upper atmosphere, would doubtless extend our knowledge of the laws of aerial phenomena, and turn it to practical account with reference to the preserving of our own health and comfort. Primarily, Mr. Glaisher proposed to determine the temperature of the air, and its hygrometrical state at different elevations up to five miles; secondarily, other of the inquiries already intimated; to compare the readings of the mercurial and aneroid barometer, and the indications of the dew point given by Daniell's, Regnault's, and the dry and wet bulb



hygrometers at different heights, especially as high up as man may reside on mountains, or troops (as in India) may have to be stationed, so as to ascertain the degree of reliance to be placed on these instruments severally; to note the elevations and characters of the different kinds of clouds; to make observations on magnetism, on aerial currents, on sounds, &c.

On account of its central position, allowing the longest run over land, Wolverhampton was at first selected as the place of ascent. Three ascents were made thence, July 17, Aug. 18, and Sept. 5; four others took place from the Crystal Palace, July 30, Aug. 20, Sept. 1 and 8; and one from Mill Hill, near Hendon, Aug. 21, where the balloon had descended the previous evening. July 17, as shown by the barometer, a height of 26,177 ft. was reached; and in descending a mass of vapor 8,000 ft. thick, and so dense that in it the balloon was not visible from the car, was passed through. Aug. 21, the balloon was released from its anchorage before sunrise, the morning being warm, dull, and cloudy; at 5,000 ft. clouds were reached; the balloon soon emerged above the dense mass of cloud it had entered, into a sort of basin or valley, surrounded by immense black mountains of cloud, which extended far above its place. Shortly afterward the appearance below became that of deep ravines of great extent, with beautifully curved outlines; while the blue sky overhead was nearly covered with *cirri* (the "mare's tail," or hair-like cloud). Presently, as the sun rose, the tops of the mountain-like clouds became silvery and golden; at 8,000 ft. the level of their summits was reached, and the light of the sun on them, and, flooding the atmosphere on either side of the balloon with orange and silver, produced a gorgeous effect. As the sun's rays warmed the contents of the balloon, it shot more rapidly upward, and other vast masses of cloud of varying shapes came into view, but still bounded in the horizon by immense piles resembling Alpine ranges. The height reached was nearly 8 miles. Sept. 1, at  $\frac{1}{4}$  mile above London, the whole length of the Thames could be traced from its mouth; and along its entire course, following all its windings, extended a cloud or fog bank bounded by the shores on either side. For half an hour, previous to descent near Woking, in Surrey, the balloon was under one stratum of cloud and above another. Of the latter, the upper surface appeared bluish white, the middle portion a pure white, the lower surface a blackish gray, and from this rain was falling to the earth. At 1,800 ft. the balloon was yet above these clouds. As afterward learned, rain had fallen from them all the afternoon. Sept. 5, the greatest altitude ever yet made by the balloonist was reached. The temperature at 8 miles high was 18°; at 4 miles (1:39 p. m.) it was 8°; in 10 minutes more the 5th mile was reached, temperature now -2°, while no dew condensed on Regnault's hygrometer, though cooled down to

-30°. Up to this time Mr. Glaisher had taken the observations with comfort; and he experienced no difficulty in breathing, although Mr. Coxwell, who exerted himself more, did so. At 1:51 p. m. the barometer corrected read 10.8 inches, showing a height of about 5 $\frac{1}{2}$  miles. Here Mr. Glaisher's sight began to fail; he strove to reach to the distance of a foot for some brandy, but could not move his hand so far; he finally saw and noted the barometer at 10 inches, true reading 9.75, showing 5 $\frac{1}{4}$  miles height, when he lost all power, his head falling to one side, then, on raising it, to the other, and finally backward; and in a few minutes more he was totally unconscious. Mr. Coxwell, who had been up in the ring, returned to the car; feeling now that he was himself becoming insensible, and being unable to use his hands, he seized the valve rope between his teeth, and thus discharged so much gas that the balloon took a downward turn. In the descent Mr. Glaisher recovered at about the same elevation at which he had become senseless; and on reaching only 24° the temperature seemed to the aeronauts very warm. Of six carrier pigeons taken up, two, thrown out at 8 and at about 4 $\frac{1}{2}$  miles in rising, dropped straight down; two others released, the one in rising, the other in coming down, at 4 miles, flew about the balloon in circles, the latter returning and perching upon it; of the remaining two, brought to the ground, one was dead, and the other for some time indisposed to exert itself. Since the instruments were placed facing Mr. Glaisher, the exact height reached in this ascent was not ascertained; but a casual observation of Mr. Coxwell on the aneroid barometer appears to show that it could not have been less than 35-36,000 ft., or at least 6 $\frac{1}{2}$  miles; and it may have been greater.

The reader is referred to the title METEOROLOGY, for some valuable results arrived at during these ascensions, in reference to atmospheric conditions; certain others belong more properly in this place. The time of vibration of a magnetic needle was only slightly greater at considerable elevations than on the earth, thus showing that up to such heights the earth's magnetic force had not materially diminished. It was observed that some sounds are transmitted much farther through the air than others that appear to be equally loud; thus, the barking of a dog was heard plainly at 2 miles; the shouting of a multitude had ceased to be audible before reaching one mile. In the voyages of Messrs. Wise and La Mountain in 1859, above referred to, the frequency and distinctness with which the aeronauts heard the barking of dogs are also noticeable.

Mr. Glaisher is led to conclude that, in order to reach great altitudes, the balloon must have a capacity of at least 90,000 cubic feet; and that even with such a balloon, except through the employment of a gas of density as low as that secured for these experiments (namely, carburetted hydrogen, of specific gravity of

870 to 840, air being 1,000), a height of six miles is unattainable. At 3-3½ miles the body of gas admitted at the earth will double its volume; hence, in order to reach 6 or 7 miles, a volume of gas that at the earth fills not more than ¼ of the capacity of the balloon must suffice to raise its entire weight, including ballast enough to regulate the descent, and prevent the necessity of landing until an exactly suitable spot is found. With a balloon of such size, and with a view to an entirely safe descent, Mr. Glaisher found it desirable to reserve for such purpose 5-600 lbs. of ballast: as this ballast must be carried to the greatest altitude reached, it becomes another condition limiting the elevation attainable in practice. To say nothing, therefore, of the question as to how great may be the actual increase of cold at heights greater than those yet reached, nor as to whether the buoyant power of the air would not have sunk too low for the density of any gas that could be used to fill the balloon, the banter offered by another aeronaut, since the publication of the above results, to accompany Mr. Glaisher to a height of 11 miles, must be regarded as idle in view of the inevitable conditions under which it appears that balloons must be constructed and worked. Again, it was found in the voyages above described, that very great altitude and an extended flight in distance are results that cannot both be secured at the same time. In no instance did the balloon keep to very great altitudes more than an extremely brief period; that this was not owing to leakage, would seem proved by its satisfactorily holding its charge over night, between the ascents of Aug. 20 and 21. Mr. Glaisher thinks the roaring sound, as of a hurricane, spoken of by some aeronauts, and ascribed by them to opposing upper currents of air, could in no way result from the cause supposed, and may have been due to the flapping about of the lower part of the partially collapsed balloon during rapid descent. Beyond this the most that he observed was a slight whining noise in the netting, at times when the balloon was mounting upward with great rapidity. He remarks that the theory of a settled wind at considerable heights to eastward or southeastward [query—to N. E. ?], and as he thinks too readily accepted, was not confirmed in these trips. Nor was the upper surface of the fields of cloud, above which at times the balloon stood, such as required by a somewhat current supposition to the effect that the upper cloud-surface is a counterpart of the earth's surface below, rising and falling in the same parts as does the latter, in hills and valleys.

It was inferred that the diminished pressure of the air at great heights exercises a very different influence on different individuals, probably through diversity of temperament and organization, and in fact also, on the same person at different times. The trials made appeared to establish it as a fact that, up to 3 miles high, observations, even of a delicate nature,

can be made as comfortably and accurately in a balloon as on the earth; while at heights exceeding 4 miles they cannot be made quite so well, because of the personal distress of the observer; and at 5 miles it requires the exercise of a strong will to make them at all. Up to 3 miles any person of ordinary self-possession may safely ascend in the car; but no person with pulmonary complaints or heart-disease should attempt the height of 4 miles; and it may be added that [at least outside the tropics] 5 miles above the sea-level is very nearly the limit of human existence. But all the conclusions relative to the making of valuable scientific observations, proceed upon the supposition that the balloon is intelligently and skilfully managed. In fact, it was Mr. Glaisher's perception of the skill of his assistant, of his great familiarity with his business (attained during more than 400 ascents previously made), and of his presence of mind, that served to inspire in himself that feeling of entire confidence and security requisite to the proper discharge of his duties in the way of observation.

The wellnigh fatal termination, however, of the trip of Sept. 5, served to call out from Mr. Isaac Ashe, at a recent meeting of the British Association, the proposition of a simple contrivance, by means of which the opening of the escape valve, through action of a weight attached to its rope, should when desirable on the part of the aeronaut be made to depend on a relaxation of his voluntary effort; so that in the event of insensibility supervening at great altitudes, the spontaneous opening of the valve should at once secure a descent into lower strata of air, the higher temperature of which would be expected to restore the luckless navigator to consciousness.

An attempt is being made in France to reintroduce the employment of the Montgolfier balloon, or that elevated by heated air. Some balloonists have even declared these safer and more easily managed than those inflated with—what is now the most usual material—coal gas. M. Goddard, an aeronaut attached to the French army, recently ascended from the Pré Catalan in a Montgolfier balloon, of a capacity of 4,000 cubic metres. This was inflated in less than half an hour, the fuel being compressed cakes of rye straw. A successful descent was made, after a journey of 26 minutes, near Maisons.

**BAPTISTS.** The Baptist family of Christian denominations embraces all those which hold that immersion is the only true form of baptism, and that adults are the only fit subjects. There are in the United States 8 different denominations with these distinctive views, viz.: the Regular Baptists, with 1,109,348 communicants in North America; the Anti-Mission Baptists, with 60,000 communicants; the Free-Will Baptists, with 58,055 communicants; the Six-Principle Baptists, with 3,000 communicants; the Seventh-Day Baptists, with 6,686 members; the Church of God (Winebronarians), with 14,000 communicants; the Disci-

ples (Campbellites), with 850,000 members; the Tunkers, with 8,200 members. The Regular Baptists are the second largest religious denomination of the United States, being exceeded only by the Methodists, and, like the Methodists, they are numerous in every State of the Union. Their progress during the last three years has not been great, the increase in membership since 1859 amounting to only 41,000.

The Baptists of the North have at present no general convention of all the churches but their large religious societies, viz.: the American Baptist Missionary Union, the American Baptist Publication Society, the American Baptist Home Mission Society, the American and Foreign Bible Society, may be regarded as a kind of substitute in respect to the churches of the Free and part of the Border States. The Southern Baptist Churches have a Southern Baptist Convention, which meets biennially, and a Southern Baptist Publication Society.

The anniversaries of most of the great religious societies of the Northern Baptists took place last year at Providence, Rhode Island. Notwithstanding the disastrous influences of the war upon churches in general, the results of the year were, on the whole, regarded as highly satisfactory. The Missionary Union showed even a small increase in its annual income, which this year amounted to \$95,198. Its missions number now 375 churches, with about 81,000 members—an increase over the last year of about 8,000. The Publication Society had issued during the year forty-one new works, and received \$56,306. The Home Mission Society had employed 90 missionaries, 12 of whom preached in foreign languages, and its receipts amounted to \$37,894. The American and Foreign Bible Society held its annual meeting in the city of New York, May 26, and reported its receipts for the last year to be \$16,688. Prior to the meeting, February 21, the Society had found itself obliged to sell its Bible House, in New York. Characteristic of the sentiments animating the Baptist community in the Northern States on the state of civil affairs are the resolutions which were unanimously passed at the annual meeting of the Missionary Union. They are to the effect that the officers and members of the Missionary Union regard the "war to put down the unprovoked and wicked rebellion as a most righteous and holy one," and that they believe "the institution of slavery to have been the principal cause and origin of this attempt to destroy the Government, and that a safe, lasting and solid peace cannot be expected short of its complete overthrow." Similar resolutions were passed by the great majority of the Baptist Associations. It was observed, in particular, that the New York and Philadelphia Associations, both of which bodies had hitherto contained a considerable number of influential men of conservative views, endorsed, this year, unanimously, the emancipation proclamation of President Lincoln.

Very little has been heard of the condition

of the Baptist churches in the Seceded States. At the beginning of 1862 the "Southwestern Baptist," published at Tuskegee, Alabama, stated that besides itself there were only three other Baptist papers published in the South. A mission has been established by Northern Baptist missionaries among the negroes in that part of South Carolina which, during the year 1862, was occupied by the forces of the Federal Government.

The Baptists in England are divided into three great classes: the General Baptists, who, in the course of time, have become Unitarians in sentiment; the New Connection of General Baptists, who hold Arminian sentiments; and the Particular Baptists, who are Calvinists. The latter are by far the most numerous. The statistics are not ascertained in England with as great care as in the United States. In 1862 the number of (Particular) Baptist ministers in England and Wales was reported as 1,806, in Scotland 89, in Ireland 17; churches, 1,245; members, 188,981; new churches organized during the year, 7—increase of membership during the past year, 9,458. The Missionary Society of the Particular Baptists, which, ten years since, sustained 45 missionaries, and 114 native preachers, has now 66 missionaries and 148 native preachers and pastors. Eight new missionaries were sent out during the last year. The educational institutions of the Baptists have of late received a valuable increase by Mr. Spurgeon's college, connected with the Metropolitan Tabernacle, the new church of Mr. Spurgeon's congregations. The institute owes its origin entirely to the zeal of Mr. Spurgeon in behalf of young men who are anxious for mental improvement and religious usefulness. The institute is called the Pastor's College, and depends for its support upon Mr. Spurgeon, who devotes a considerable portion of his income to its maintenance. It contained at the close of last year twenty-three young men, who were in training for the ministry, and whose theological education is under the special superintendence of the pastor. Besides these there were upward of a hundred general students, who, with the others, receive instruction from paid professional tutors. The majority of the students are engaged in business, but, with a view to intellectual advancement, spend their evenings in study and attendance upon classes. An important movement toward a union with Congregationalists and Presbyterians in one new denomination was commenced last year, and several prominent Baptist ministers, as Mr. Spurgeon, declared themselves in favor of it. Many associations, on the other hand, have declared a determined opposition to it.

Twenty-six of the thirty-eight associations belong to the Baptist Union, which body held its fiftieth annual session in London, April 25th, 1862, and unanimously passed a resolution expressing "unfeigned grief for the calamity of civil war in the United States, and for the sin

of slavery, with its consequences, on account of which that war must be braved."

Upon the continent of Europe the organization of Regular Baptist churches is of recent origin, but they have met with extraordinary success. In Germany, where Rev. Mr. Oncken, who is still living, established the first mission, in 1834, they had in December, 1861, 538,067 members, 53 churches, and 819 stations and out-stations. In connection with the German Mission are, in Denmark, 16 churches, with 1,670 members; in Switzerland, 1 church, with 201 members; in France, 1 church, with 100 members; in Poland, 1 church, with 332 members. The last accounts from Germany represent their progress as being still very rapid, notwithstanding they were subject to a fierce persecution in several States, especially in Mecklenburg. Still more remarkable is the progress of the Baptists in Sweden, where, in spite of a law threatening with exile every seceder from the State Church, their number has increased so rapidly that, on January 1, 1862, they counted 7 associations, 150 churches, and 4,865 members. With four exceptions, all these churches originated through the labors of colporteurs employed by the American Baptist Publication Society. In Russia and Poland they have only recently commenced to labor, but there also, notwithstanding the persecution which they are suffering, at the instigation of the Lutheran clergy, great success seems to await them. In Courland, nearly two hundred have been baptized; in the Crimea, the first secession from the State Church has taken place; in Poland, two churches have been formed, and twenty-four preaching stations.

In France, Baptist missions were established about twenty years ago by the American Baptist Missionary Union, and a few of them have become self-supporting. In October, 1861, the Executive Committee of the Missionary Union found it necessary, in consequence of its financial condition, to suspend pecuniary aid to the missions. This announcement was received by the Baptist missionaries with profound sorrow, but also with an unwavering determination to persevere in their work. The report made of the French churches at the anniversary of the Missionary Union, in 1862, showed that the aggregate membership had increased from 304 to 819, and the pecuniary contributions were larger than during the preceding year. The missions are, however, still in their infancy, numbering, as yet, only four preachers and two colporteurs. The "Annuaire Protestant" for 1868 gives the names of nine churches. The Baptists do not yet enjoy full religious toleration, and one of their chapels has been for several years, and still is, under the interdict of the civil authorities. Yet it is possible that freedom of worship will ere long be fully enjoyed. Besides these missionary congregations established in France by the American Baptist Union there are some remnants of the Baptist churches of the six-

teenth century, especially in the departments of Doubs, Haut-Rhin, and Vosges. Little is known about their statistics. The names of four congregations, one of which has a membership of 300, are given by the "Annuaire Protestant."

Among the missionary churches which have been established by the Baptists of America and England, those of Farther India have been especially successful. Some tribes of the Karen have been almost wholly Christianized, and are beginning to form the nucleus of a Christian nation. During the past year the converts have increased by scores and even hundreds. The desire and efforts of the Karen churches to establish schools, not only for the training of native preachers and teachers, but in all their villages, for the general instruction and elevation of their people, and especially of the females, indicates a marked growth, and in a direction that promises to yield permanent and abundant fruit. The progress among the Burmans during the past year, as heretofore, has been comparatively slow. A new mission has been commenced to the Shans, who are probably the most numerous of the many subordinate tribes that make up the population of Burmah, though no accurate statistics of their numbers have thus far been ascertained. Like the Burmans and Karens, they are Buddhists, but they are a race distinct from either, and speak a different language. They have long been settled in the territory of Upper Burmah, but a few years ago about ten thousand emigrated to the British provinces, and settled in the vicinity of Toungoo. There the first Baptist mission was commenced among them in 1861, and the first church organized in 1862. The mission in Siam continues to enjoy the full toleration of the enlightened king. Altogether the membership in the Baptist churches in Farther India amounted, in 1862, to 17,739.

Other missionary churches have been established by the American Baptist Missionary Union and the Southern Baptist Missionary Society, in China; by the American Free-Will Baptists, the English Baptist Missionary Society, and the English General Baptist Missionary Society, in India; by the Southern Baptist Missionary Society and the English Baptist Missionary Society, in Africa. In 1860, the missions in India and China had a membership of about 2,600; those in Africa of about 1,400.

The number of Baptists in Australia was estimated, in 1862, at about 10,000.

**BAROMETER.** In the common or mercurial barometer, as is well known, the pressure of the atmosphere takes effect directly on the surface of mercury in a cup, or upon a mass of mercury through the walls of a reservoir which are made flexible in some part. The height at which the pressure thus exerted suffices to sustain the column of mercury in the barometer tube, serves, conversely, as a convenient measure of the pressure itself. But as the density of the air diminishes at increased heights in a ratio which, in the average, is fixed and known,

and as, in ascending, portions of the air are continually left beneath, there results from these two causes an average fall of the mercurial column strictly corresponding with the elevations attained; and on this principle the barometer becomes a convenient and nearly—though thus far not absolutely—correct means of determining heights. Thus, the average height of the column at the sea level being about 80 inches, a fall of one half this length occurs when the elevation of 8.43 miles (Cooke: "Chem. Physics") is reached; at double this elevation the length of column is  $\frac{1}{2}$  that at the sea level, and in the like ratio for all elevations whatever; so that by calculation the elevation can always be deduced with tolerable correctness from the barometric indications. Of course, in effecting this, corrections are required for temperature, and for any other agency which may cause the atmospheric pressure at the place to vary independently of the mere fact of elevation.

In the so-called aneroid and metallic barometers, several forms of which are now constructed, the atmospheric tension is allowed to take effect directly on the thin flexible sides of a small metallic case, or upon a compressible tube or chamber only inside the case, and which is acted on with greater force as the pressure is increased, and the reverse; a connection by delicate mechanism from the movable wall or chamber, as the case may be, to an index moving over one face of the case, serving to show the pressure; and the indications of these instruments are readily compared with those of the mercurial, the corresponding values being marked on a scale over which the point of the index is caused to travel.

Messrs. Horne and Thornthwaite, of London, have during the year produced a carefully constructed aneroid barometer, a new feature of which is that it is intended to show or measure heights by simple inspection. The instrument is of about  $2\frac{1}{2}$  inches diameter; hence, highly portable. The face is graduated in two circles, the outer being the usual scale, and showing the pressure in inches and tenths of an inch. The inner circle is graduated in spaces—of course decreasing in length from the greater pressures up—which correspond with hundreds and thousands of feet. Supposing the density and tension of the atmosphere not to vary with temperature nor other meteorological conditions, but to remain at all heights precisely that due to height only, the mere observation of the place of the index shows the elevation above the sea level at the time, and a comparison of two such indications shows the difference of heights between two stations. The calculation saved is that showing relation of pressure to elevation. A correction for temperature is, however, required; and a convenient table giving the corrections for degrees of Fahrenheit, and based on a formula of Laplace, is furnished with the instrument. Known fluctuations of pressure occurring independently of heat and elevation should also be allowed for;

so that it is doubtful whether the instrument can serve more conveniently than any other for the most accurate measurements; though it must still prove very useful for cases in which ordinarily correct measurements only are required.

Mr. J. Ball presented before the British Association (1862) a quite abstruse paper on corrections required in determining heights by means of the barometer, the general bearings of which, rather than those details suited only to the use of the scientific explorer, will here be given. Serious errors are still involved in the ordinary process of reducing barometrical observations taken for hypometrical purposes. The process has involved two assumptions—neither of them wholly true: 1, that the volume of a column of air unequally heated in its different parts is nearly the same as that of an equal weight of air having throughout a temperature equal to the mean of the former; 2, that the mean temperature of the column or stratum of air between two unequally elevated stations is equal to the mean of the readings of the thermometer in the shade at the two stations. The practical error arising from the second of these assumptions only is important. The subject has lately been under investigation by M. Plantamour, the distinguished astronomer of Geneva. He first ascertained by careful levelling the height of the Great St. Bernard above Geneva: his comparison of the barometrical observations of 18 years then shows that the mean height deduced from them is less by 14 English feet than the true height. This result he thinks due to an abnormal depression of the mean temperatures of Geneva, owing to contiguity of the lake. The readings of the barometer and thermometer at the observatories of Geneva and the St. Bernard are taken at 9 hours or epochs of each day. Calculating the height of the mountain by the elements corresponding to the 9 epochs severally, and for the months of June to September inclusive, for successive years, he obtains a series of differing measures of the height—those given by the hottest hours of the day being in excess of the true height, and those of the cooler hours falling short. He thereupon formed a table showing the correction necessary for each of the 9 epochs at Geneva, for the months named; and introduced a further and more difficult correction for the variation which the temperatures may be undergoing (at the moment of a given observation) from the mean of the corresponding day and hour. The paper will doubtless appear in the publications of the Association.

Prof. Hennessy read before the Association a paper on the vertical movements of the atmosphere, as detected by a new form of anemoscope (*ανεμος, wind, σκοπεω, I observe*). The instrument is so constructed as by an index or pencil to show, and also to record, the vertical oscillations of otherwise quiet, or moving bodies of air. Such non-horizontal movements are found to be more prevalent about midday than at

any other time. They often commence abruptly, and are usually the precursors of considerable horizontal disturbance; while a gradual and regular diminution in their amount appears to precede and so to indicate a regaining of the atmospheric equilibrium—hence, to prelude fine weather. Horizontal movements of the atmosphere are seldom such alone; they are usually blended with more or less of vertical movement, so that winds, like the disturbances they cause in the equilibrium of bodies of water, have their undulations or waves. The author of the paper is led to suppose that the study of this atmospheric pulse or undulation, in connection with that of the actual advance of the wind, may yet prove of value as a test of changes of weather.

Prof. Regnault ("Philos. Magaz.," Sept., 1862) proposes an arrangement by which both temperatures and pressures at different heights in balloon ascents can be known without the necessity of accurately observing and recording at the time. Some 20 tubes are previously prepared for each of the purposes, each series standing against a suitable frame or back; and the aeronaut has, at the moment of an observation, only to turn a stop-cock for one (air) thermometer and one barometer tube, marking the time of doing so; and so on through the two series, at such intervals as he may desire. Upon returning to the earth, the several tubes in which change in length of column was arrested in the manner named, show what was the temperature and the atmospheric pressure—hence, again, the elevation—at the times marked against them severally. For some points in connection with the use of the barometer for predicting changes of weather, see METEOROLOGY.

BATESVILLE, the capital of Independence county in Arkansas, is situated on White river 400 miles from its mouth and 90 miles north northeast of Little Rock, the capital of the State, and 115 miles from Memphis in Tennessee. Small steamers can ascend the river to Batesville at nearly all seasons of the year. It is the most important town in that part of the State, and was thriving under the influx of emigration. Its population was nearly 3,000. It was occupied by Gen. Curtis for some time during the spring of the year while he was waiting for supplies. These failing to reach him by the river, were finally sent by land from St. Louis.

BATON ROUGE, the capital of the State of Louisiana, is situated on the east bank of the Mississippi river, 129 miles above New Orleans. Its location is high, being about twenty-five or thirty feet above the highest overflowings of the river, and extremely healthy. The esplanade in front of the town presents a fine view of the majestic Mississippi and the rich cultivated tracts on its banks. Below the city the broad river sweeps through a plain which is covered with plantations of sugar cane and adorned by splendid villas and gardens, and groves of tropical fruit trees. The

seat of government of the State of Louisiana was established at this city in the year 1847. The State House was a building of fine appearance, situated immediately on the bank of the river. It was burned during 1862, while the city was occupied by Federal troops. It was supposed to have been set on fire, and such was the deficiency of means with which to extinguish it, that all the efforts of the troops were unsuccessful. It was first occupied by Federal troops immediately after the capture of New Orleans. The attack upon the city by the Confederate forces under Gen. Breckinridge was made on the 5th of August. (See ARMY OPERATIONS.) It was subsequently evacuated in order to concentrate the force at New Orleans under Gen. Butler, and again occupied after Gen. Banks took command of New Orleans.

BEAUFORT, the capital of Carteret county, North Carolina, is situated at the mouth of the Newport river, a few miles from the sea. It is eleven miles from Cape Lookout and one hundred and forty-three miles by railroad from Raleigh, the capital of the State. The harbor is the best in the State, and the commerce was considerable in turpentine, resin, and other products of the pine. The population in 1853 was about 2,000. The entrance to the harbor was guarded by Fort Macon, which was seized by order of the governor after the surrender of Fort Sumter, and surrendered to the United States forces under Gen. Burnside. (See ARMY OPERATIONS.)

BECKWITH, Major-General JOHN CHARLES, C. B., an English officer and philanthropist, died at La Tour, Piedmont, Italy, July 19, 1862, aged 72 years. Gen. Beckwith entered the British army in his fifteenth year and served in Hanover in 1805, and subsequently in Sweden, Portugal, and Spain, being in almost every considerable action until the battle of Waterloo, where he lost his left leg. He was at this time and had been for two or three years, on the Duke of Wellington's staff, and after his retirement on half pay was a favorite with the duke, who often invited him to Apsley House. It was on one of these visits that an incident occurred which influenced his entire subsequent career. The duke being particularly engaged at the time of his call, he was shown into the library to wait till he should be at leisure. To while away the time he took from the shelves Gilly's "Waldenses." He had read but a few pages when summoned to the duke's room, but the book had made such an impression on him that he purchased a copy of it, and collected whatever else he could find relating to these poor mountaineers, and in 1827 visited Piedmont to become acquainted with them. His first visit lasted but three or four days; the next year he spent three months in their valleys, and afterward six months, till finally he made his home at Torre, in the valley of Piedmont. Here he exerted himself for the improvement of the people, and finding education much neglected, in-

cited them to rebuild their schoolhouses and improve their schools, contributing largely of his own means to aid them in these objects. In this way he opened and restored 120 district schools, and aided by Dr. Gilly, then dean of Durham, and other friends in England, set himself to improve the parochial schools and to enlarge the college and divinity school at Torre. In 1846, encouraged by the liberal policy of Charles Albert, he determined to attempt the nationalization of the Waldensian Church. The Waldensians had since 1620 spoken French, and used it in their schools and religious services. He determined to encourage the use of Italian in both school and pulpit, and for this purpose sent six young pastors to Florence to acquire the pure Tuscan dialect. This accomplished, they taught the teachers of the schools in the valleys, and in about two years the people became sufficiently conversant with the language to attend religious services in it. In 1848 permission was given to erect a Waldensian church or chapel at Turin, and Gen. Beckwith raised a sum sufficient to build a tasteful edifice on the Viale de Re, and thenceforward made Turin his winter residence, though his summers were spent in the valleys visiting his schools and acting as the father of the people. Late in life he married an intelligent and amiable Waldensian damsel. For a few years past he had spent some months at Calais for his health, but finding his end approaching he hastened back to Torre to lay his bones among his beloved Waldensians.

BERESFORD, Right Hon. and Most Rev. LORD JOHN GEORGE, Archbishop of Armagh, Primate of all Ireland and Metropolitan, and Chancellor of the University of Dublin, born November 22, 1778, died at Auburn, County Down, Ireland, July 18, 1862. He was the second son of George, first Marquis of Waterford, and was educated at Eton and afterward at Christ Church, Oxford. He was appointed dean of Clogher in 1801, and in 1805 consecrated bishop of Cork. In 1807 he was translated to the see of Raphoe, in 1819 to that of Clogher, in 1820 to the archbishopric of Dublin, and in 1822 to the archiepiscopal see of Armagh and the primacy of Ireland. In 1821 he succeeded Lord Manners as vice-chancellor of the University of Dublin, and in 1851, on the death of the King of Hanover, was elected chancellor. He was a man of noble, commanding, and dignified person, of excellent judgment and discretion, of genial affectionate disposition, of remarkable equanimity of temper, and of a most generous and liberal nature. He endowed the observatory of Armagh; founded a professorship in the University of Dublin, and built the campanile for it at a cost of £8,000; gave nearly £6,000 to the college of St. Columba near Dublin, restored the cathedral church of Armagh at a cost of £30,000, sustained its church service in the highest condition, and made large contributions to the public library,

the royal school, and for forty years contributed £400 a year for the church education schools of Armagh. His private charities, never ostentatious in their character, and often unknown except to their recipients, amounted, it has been ascertained since his death, to over £2,000 per annum. At his death, men of all denominations, even including the Roman Catholic Primate, united in doing the last honors to his remains.

BETHUNE, GEORGE W., D. D., an American clergyman of the Reformed Protestant Dutch Church, born in the city of New York in 1805, died in Florence, Italy, April 27, 1862. He was the son of Divie Bethune, a New York merchant, distinguished alike for his eminent business abilities and his unaffected piety and philanthropy. His mother was the daughter of the saintly Isabella Graham, whose memory is embalmed in so many of the charitable institutions of New York. His youth was passed in his native city, but at an early age he entered Dickinson College, Carlisle, Penn., of which his father's former pastor, the eloquent John M. Mason, D. D., had then recently become president. Young Bethune's college career was marked by no special incidents, and he attained no great distinction as a scholar. But near the close of his college course he became the subject of a religious change, and soon after graduating determined upon studying theology. He accordingly entered Princeton theological seminary in 1822, and after completing his course was ordained as a Presbyterian minister in 1825, having just completed his 20th year. He accepted an appointment about the same time as chaplain to seamen in the port of Savannah. In 1826 he returned to the North, and transferred his ecclesiastical relations to the Reformed Dutch Church, settling soon after at Rhinebeck, N. Y., where he remained four years, when he was called to the pastorate of the First Reformed Dutch church in Utica. In 1834 his reputation as an eloquent preacher and an efficient pastor led to his receiving a call from a Reformed Dutch church in Philadelphia, which, after deliberation, he accepted. He remained in that city till 1848, and was greatly esteemed as a preacher and a thorough and critical belles-lettres scholar. In 1848 the "Reformed Dutch Church on the Heights" in Brooklyn, N. Y., was organized, and Dr. Bethune was earnestly solicited to become its pastor. He consented, and its beautiful church edifice was erected under his own eye. For eleven years he continued in the pastorate of this church, but in 1859 his impaired health led him to resign and visit Italy. While residing at Rome he had charge of the American chapel, at that time the only Protestant place of worship in the "Eternal City." He returned in 1860 with his health materially improved, and was for some months associate pastor of a Reformed Dutch church in New York city; but his health again becoming impaired he returned to Italy in the summer of 1861, and

after some months' residence at Florence, died from an attack of apoplexy. Dr. Bethune was profoundly versed in the earlier and later English literature, and had achieved distinction as a writer by his careful editing of the "British Female Poets with Biographical and Critical Notices," and his admirable edition of Izaak Walton's "Complete Angler," for which his own fondness for piscatorial sports also qualified him. His original works also possessed great merits. Among these were "Lays of Love and Faith," a volume of poems remarkable for their beauty of sentiment and their mellifluous rhythm; "Fruits of the Spirit," a volume of sermons; and two smaller works, "Early Lost Early Saved" and "The History of a Penitent." One of his latest public efforts before leaving his native city for his last voyage to Europe, was a speech delivered at the great mass meeting at Union Park, April 20, 1861, in which with more than his ordinary fire and eloquence he gave utterance to his patriotic emotions.

**BLOCKADE.** The Federal blockade of the Confederate ports continued unchanged during 1862. Some questions of interest arose in England during the year as to its efficiency. But being the great commercial nation of Europe, the views adopted by her were readily acquiesced in by other governments, whose commerce was less obstructed.

The first question relative to the effectiveness of the blockade was raised by the commissioner from the Confederate States to London, John M. Mason, of Virginia. It was presented in the following letter to Earl Russell, the British Minister for Foreign Affairs:

109 FROCADILLY, Feb. 17, 1862.

I have the honor to transmit to your lordship herewith (by permission) returns of vessels entered and cleared at the blockaded ports of the Confederate States of America at the respective dates to which they refer. Your lordship will observe that the returns from the ports of Charleston and Savannah are only up to the 31st of October last; from New Orleans, Mobile, Pensacola, and Lavada, to the dates given in August; and from Wilmington till 10th September. Your lordship will further observe, that in the list from New Orleans a large number were inland by the river Mississippi, and therefore involved no question of a breach of blockade. Wishing to be perfectly frank, it may be proper to remark also, that others from some of the ports may have been *quasi* inland; that is to say, through the estuaries and sounds along the coast. I state as an example, from New Orleans to Mobile, where the route for small vessels may or may not have been through the inland sounds. But in regard to the latter, I do not see why the obligations of a blockade do not extend as fully to them as by access to the port from the open sea. These estuaries or sounds are accessible by inlets from the sea, and, if not guarded, the port to which they lead may be reached as successfully by sea going vessels of light draft through those channels as by a direct sea route. That the Government of the United States so considered, is proved by the fact that the inland sea communication between New Orleans and Mobile, Charleston and Savannah, and perhaps other places, is claimed to be blockaded by naval forces of that Government. The transcripts herewith were furnished me by my Government, to be communicated to your lordship. Although

VOL. II.—13 A

purporting to be copies of the original returns, they were copies made at the proper department at Richmond from those returns, and are therefore authentic. I ask permission also to include herewith a printed list of vessels entered and cleared at ports in Cuba from and to the blockaded ports of the Confederate States. These, for the most part, are enumerated in September; and all for the months of November and December are, of course, not included in the transcripts from my Government. This paper, sent to me from Havana, was taken from official documents there by a gentleman of intelligence and integrity, well known to me, and worthy of entire reliance. The marginal notes are, of course, unofficial. The fact (assumed) of the arrival of the vessels cleared (at their ports of destination) was matter of notoriety, from the almost daily intercourse between Havana and these ports. I have no official returns from my Government for the months of November, December, and January, to be accounted for in the fact that until very recently it could not be known when I might reach London. But, as your lordship is doubtless aware, breaches of the blockade at most if not all of these ports by vessels of large as well as of small tonnage, both inward and outward bound, have been, during the last three months, and yet are, constantly reported. J. M. MASON.

Previous to this communication various reports had been sent in by the British naval officers and consuls respecting the blockade.

Consul Bunch, in a series of letters from Charleston, extending from the 15th of May to the 4th of September, 1861, frequently alluded to the inefficiency of the blockade of that port, as shown by the facility with which vessels continued to enter and leave the port.

Commander Hickey, of H. M. ship *Gladiator*, represented, under date of July 23, that the blockade of the Southern coast was merely nominal.

Commander Lyons, of the *Racer*, writing in July, represented that Savannah and Charleston were effectually blockaded, but many other harbors and inlets along the coast were perfectly free from blockade. The same officer, on the 19th of December, reported some instances of breaking the blockade at Charleston and Wilmington, and inferred therefrom that the blockade, either intentionally or through want of ordinary vigilance, was not effective.

Captain Ross, of the *Desperate*, reports the result of a visit to Galveston in December. The blockading ships were visible, and he was of opinion that vessels might easily escape from Galveston or St. Louis Pass. At the other ports which he visited the blockade was generally actively maintained.

The views entertained by the Government from these and other representations, were expressed in a letter from Earl Russell to Lord Lyons, dated Feb. 15, 1862, two days earlier than the date of Mr. Mason's note above. They were as follows:

FOREIGN OFFICE, Feb. 15, 1862.

MR LORD: Her Majesty's Government have had under their consideration the state of the blockade of the ports of Charleston and Wilmington. It appears from the reports received from her Majesty's naval officers that, although a sufficient blockading force is stationed off those ports, various ships have successfully eluded the blockade. A question might, therefore, be raised as to whether such a blockade should be considered as effective. Her Majesty's Government,



however, are of opinion that, assuming that the blockade is duly notified, and also that a number of ships are stationed and remain at the entrance of a port, sufficient really to prevent access to it, or to create an evident danger of entering or leaving it, and that these ships do not voluntarily permit ingress or egress—the fact, that various ships may have successfully escaped through it, as in the particular instances here referred to, will not, of itself, prevent the blockade from being an effective one by international law.

The adequacy of a force to maintain a blockade being always and necessarily a matter of fact and evidence, and one as to which different opinions may be entertained, a neutral state ought to exercise the greatest caution with reference to the disregard of a *de facto* and notified blockade, and ought not to disregard it, except when it entertains a conviction, which is shared by neutrals generally having an interest in the matter, that the power of blockade is abused by a state either unable to institute or maintain it, or unwilling, from some motive or other, to do so. RUSSELL.

The subject was brought before the House of Commons on the 7th of March by Mr. Gregory, who moved for copies of any correspondence subsequent to papers then before the House. In support of his motion, he contended that the efficiency of the blockade of the Southern ports was a question of great importance to England and to Europe, and he asserted that her recognition of it, in its present state, had exposed her to severe criticism on the part of foreign jurists. Amongst others, M. de Hauteville, one of the most eminent of modern French writers, had charged England with conniving at an illegal blockade, and that she did so not from any friendly feeling toward the United States, but in order that she might make it the basis for enforcing her own arrogant pretensions, when, having become a belligerent ourselves, it might be to her interest to set aside the principles of international law. Her justice and impartiality, in fact, were involved in this matter. If the blockade is ineffectual, she was conniving at the use of a weapon of warfare by one belligerent which it is not in the power of the other to employ, and thus acting unjustly to fair traders, by making commerce a matter of smuggling, gambling, and speculation. The opinions of the neutral powers were almost unanimously against the legality of the blockade. Hitherto it had not fulfilled any of the conditions which could constitute it legal and efficient. On the contrary, steamers of light draught have continually run it, and were daily plying between the various ports of the Southern States. In conclusion, he urged that if England continued to connive at an illegal and inefficient blockade in order to conciliate the United States, the Declaration of Paris would be, so far as it regarded the Confederate States, a mockery, as regarded international law, a delusion, and, with respect to the trade and commerce of the world, a snare.

Mr. W. E. Foster denied that the blockade was ineffective, and stated that the lists of upward of three hundred vessels, which had been handed in by Mr. Mason as a list of the vessels which had broken the blockade, had, on examination, dwindled down to nineteen,

and most of these had escaped on dark and stormy nights, thus proving the stringency, rather than inefficiency of the blockade. He also reminded the House that during the war between Great Britain and her revolted colonies in America, no less than five hundred privateers succeeded in getting out of American ports.

The Solicitor-General quoted numerous precedents to show that the present blockade was as efficient as other blockades had been in former years, and that it would be a violation both of international law and of the principles of neutrality to break it. In 1798 public notification was issued by the British Government that there would be a rigorous blockade of Havre. A force was sent out to establish the blockade, but the commander was so remiss in the execution of his duty that he habitually allowed ships to run in, so that practically it might be said there was no blockade at all. Yet, it was nevertheless held that so long as a force remained and the notification was not ignored, the blockade was considered to be in existence, and any neutral vessel breaking it was liable to capture. That was, he contended, a case strictly analogous to that of the blockade of the Southern ports, with this exception, that the duties of the blockade in force in the latter instance had been more vigorously executed. He complimented the speech of Mr. Foster, asserting that the facts the member had laid before the House were wholly unanswerable. The returns received by the Government fully established the accuracy of his statistics.

This motion was negatived without a division.

Subsequently, on the 10th of March, Lord Stratheden renewed the motion. At the same time he stated that his object was not to declare that the blockade ought to be raised, or any means to be adopted with that view, but to show that toward one of the belligerents in America—the Southern, or insurrectionary power—England had assumed an attitude which suspended, if it did not violate neutrality, and that to restore that neutrality some further action was necessary. Her attitude toward that power arose out of a despatch addressed by Earl Russell at the head of the Foreign Office to Lord Lyons on the 15th of February. About July or August last England appealed to the Government, at Richmond to induce them to accede to the principles of public law which were laid down by the great powers at Paris in the year 1856. The negotiation was conducted by a gentleman of South Carolina, who had the confidence of the British consul at Charleston and of Lord Lyons; and although the Richmond Government might have declined to receive the proposition on the ground that they could not hear a negotiator from a power which refused to recognize the place they claimed in the society of nations, they did not act on that feeling, but on the 13th of August the Congress of the Southern

States resolved to embrace the principles laid down in the Treaty of Paris, with the exception of that relating to privateering, which they had not been asked to adopt. When the President communicated this decision to the negotiator, he pointed out that it had been adopted in the sanguine expectation that England should adhere strictly to the article of the treaty which laid down, that blockades to be binding should be effective. The despatch of the 15th of February, which was not called for by any question or any emergency, sanctioned, on the part of her Majesty's Government, the blockade as it had been carried on at Wilmington and Charleston, where it was notorious that it had been less strict than on any other portion of the seaboard from the north of Virginia to the extremity of Texas. Thus the attitude which England had adopted toward one of the belligerents had been to induce them to make a generous concession on an understanding from which she seemed to have departed. The effect of that despatch clearly was to release the Government of Washington from the necessity of maintaining at any port of their coast a more stringent blockade than that which existed at Wilmington and Charleston.

Earl Russell in reply to these views said: I quite admit the right of the noble lord to call into question the conduct of the Government with respect to the blockade; nor, indeed, should I complain if any noble lord were to call into question the whole of their conduct with respect to the unfortunate differences which have taken place in America; for I am convinced not only that that policy is founded on reason and can be justified by argument, but also that it is generally approved by the country. With respect to this particular question of the blockade—and I shall not detain your lordships by entering into any other—it was, of course, a matter of serious consideration with her Majesty's Government from time to time in what manner they should act. There are various questions connected with a blockade which they had to consider. The first was, whether there was sufficient authority for instituting it. Lord Stowell says that a blockade must be the act of a sovereign authority. This was the act of the President of the United States, who, on the 19th of April, issued a proclamation declaring that the blockade was about to begin, and that act was followed by armed ships of the United States blockading the several ports and warning vessels off the coast. Therefore there can be no question as to the authority by which the blockade exists. Then, with regard to the means which the President, as the organ of the Government of the United States, has employed, of course at first they were very deficient, but I think that these papers and everything we have heard show that the Government of the United States have been most desirous so to augment their squadron and so to employ their ships that there might be a sufficient force to

establish an effective blockade. It was a matter of great importance to them—a vital point of their policy, and therefore one cannot doubt that they would use every means in their power. As early as the 15th of July, when complaints were made in some New York newspapers that the blockading squadron was not sufficient, I find that they had then thirty-four men-of-war, of 56,000 tons, with 726 guns and 10,113 men. That shows that they had made great efforts to establish an effective blockade. It might be said, again, at the commencement that the blockade was too extensive, and that it was impossible that so extensive a blockade should really be efficient; but we must recollect that we ourselves in our American war instituted a blockade of 2,000 miles of coast, and the difference between 2,000 miles and 8,000 miles is not so great as to authorize us to make any objection to the blockade on that account. But in a blockade of 8,000 miles of coast, although it is such a blockade as we ourselves should have established, and such as the law of nations recognizes, with several large ports and many small ones to watch, there were sure to be many irregularities in the conduct of it. Yet we find, generally speaking, that there has been an intention to station ships off the different ports, and that ships have been stationed there. Thus the blockade of Charleston was effective on the 11th of May by the ship Niagara; Pensacola was blockaded on the 18th of May; the blockade of the Mississippi was effective on the 26th or 27th of May, and Savannah was blockaded on the 28th of May, each port with a sufficient number of ships for the purpose. The noble lord says that the blockade of Charleston was interrupted on some day in May; but he himself read a letter in which it is stated that the blockade was renewed by another ship on the 5th of June. There was also an account of another ship being added on some day in July or August, and there is no reason to suppose that there had been no ships of war before that port, and the whole question that arises is as to the interruption of the blockade between the 15th or 23d of May and the 4th of June. If any ship had been taken at that time into a prize court it might well have been argued by the owners that there was an interruption, and that no blockade existed; but that does not affect the general question of the blockade of the southern coast of America. And let it be remembered above all, that if there were an ineffectual blockade the first place in which we should hear of it would be in the American prize courts. When a merchant vessel had been taken into one of those courts it would be quite competent for the owners to plead that there was no effective blockade, and that, therefore, the vessel not having broke it, could not be legally condemned. No one will say that there are not judges in America quite competent to decide questions of international law—judges who have inherit-

ed the precepts and doctrines of such men as Chancellor Kent and Justice Story—quite competent to pronounce judgment according to law, and who, I believe, would not have departed from the law in their decisions in such cases. But I do not find that there has been any real discussion in the prize courts of America, except, perhaps, in one or two instances, with respect to the efficiency of the blockade. I must confess to the noble lord that the many instances which are given by Consul Bunch and others of the vessels which have run the blockade, induce me to consider the whole of this question with a view to deciding what the course of the Government should be. But, in saying that many vessels have run the blockade, I think there is great exaggeration, and there is great misapprehension when lists of vessels are given which are, in fact, vessels belonging to the Southern ports, which run out of creeks and creep through shallow waters in order to reach another port on the same coast. These are mostly small vessels from fifty to three hundred and fifty tons, and it is stated in one of these letters that they cannot be regarded as vessels of such size and importance as to argue that the blockade was inefficient which allowed them to escape. Your lordships know very well that in 1806 the Government of this country announced a blockade extending from Brest to Dunkirk, but during that and other blockades which we instituted on the French coast there were many coasting vessels which went from one port of France to another, entirely escaping the blockade. But would that have justified either America or any other neutral power in saying, "This blockade is ineffective, and we will not acknowledge it, and we require you to give up the vessels which you have seized for breach of blockade." It certainly would not have justified such a course. But there is another consideration. Has the Southern coast had a free and uninterrupted communication with Europe? Have your lordships heard that cotton has arrived in its usual quantities here, and that the manufactures of Great Britain and France have arrived freely at the ports of the States which are now in a state of civil war? On the contrary, the intelligence which we have received shows that there has been no such uninterrupted intercourse, but that great inconvenience has been suffered by the inhabitants of these Southern States, owing to the existence of that blockade which is said to be ineffective. On the question of the efficiency of the blockade it was desirable to consult the law officers of the Crown; and after having done so I wrote the despatch to Lord Lyons, stating that :

Her Majesty's Government, however, are of opinion that, assuming that the blockade is duly notified, and also that a number of ships is stationed and remains at the entrance of a port sufficient really to prevent access to it or to create an evident danger of entering or leaving it, and that these ships do not voluntarily permit ingress or egress, the fact that various ships may have successfully escaped through it will not of

itself prevent the blockade from being an effective one by international law.

This was the deliberate opinion of her Majesty's Government on the subject. I cannot give the papers to which the noble lord refers, on the very ground on which he asks for them. He says, perhaps there may be papers that may show the blockade he thinks ineffective may really have been effective. There are no such papers; there are no papers that can make the case stronger for the Government than those which have been given: the Government is willing to leave your lordships to judge the case from the whole effect of the papers that have been already printed. As to any representations from the Government of France that it considered the blockade ineffective, I must state that no such communication has ever been made to her Majesty's Government. The noble Lord has asked whether the Government of the Southern States acknowledges the second and fourth articles of the Declaration of Paris. It has declared that it does acknowledge them. We have entered into no engagement with that Government. It is our duty to see that the Declaration of Paris is agreed to independently of any such engagement; that is our duty with regard to all neutral nations, and with regard to the peace of the world.

The subject came up before the French Legislature about March 13, when M. Calvert Rognait said: "I wish to examine whether the blockade of the Southern ports is maintained by a force respectable enough to constitute this danger. I assert," said the speaker, "that it is not, and think that no more conclusive proof of my assertion can be given than the very long catalogue of ships of all sorts which have entered or quitted these ports since the notification of the blockade. Authentic documents, letters from honorable merchants and ship-owners, show that any ship leaving for South America can be insured by a premium of 7½ to 15 per cent." The honorable member went on to say that Earl Russell had written a despatch to Lord Lyons to the effect that, although many ships had forced a passage, still the blockade of the port of Charleston had been regularly announced; and that, as ships of the American navy had been charged with its maintenance, there was ground to regard it as effective. In that despatch Lord Russell departed widely from the declarations of the Paris Treaty, and from the language of the circular of the French Minister of Commerce.

In reply, M. Billault, on the part of the Government, said: "One of the honorable members has expressed doubts as to whether the blockade established by the Northern States is effective, and appears to see an opposition between English and French tendencies on the subject. Such is not the case. The principles laid down by the two governments as to the conditions necessary to render the blockade effective have been mutually accepted. Earl Russell has laid down the principle that the

blockade is effective. The reason was that considerable prudence is necessary in this American question, and that it is important that the powers interested should act in concert. Those powers do not think that the effective character of the blockade can be denied, and they respect it."

In the month of June a memorial from certain British merchants and shipowners in Liverpool was addressed to Earl Russell, as principal Secretary of State for Foreign Affairs, in which they stated that they viewed with considerable anxiety and apprehension the hostile attitude assumed by Federal cruisers in the Bahama waters, and prayed that steps might be taken to protect British shipping in those waters, and to put a check on the seizures so repeatedly made by those cruisers. The reply of Earl Russell, on July 5, was as follows:

I am to state to you, in reply, that it is alleged, on the other hand, by Mr. Seward and Mr. Adams, that ships have been sent from this country to America with a fixed purpose to run the blockade; that high premiums of insurance have been paid with this view; and that arms and ammunition have been thus conveyed to the Southern States to enable them to carry on the war. Lord Russell was unable either to deny the truth of those allegations or to prosecute to conviction the parties engaged in those transactions. But he cannot be surprised that the cruisers of the United States should watch with vigilance a port which is said to be the great *entrepot* of this commerce. Her Majesty's Government have no reason to doubt the equity and adherence to legal requirement of the United States prize courts. But he is aware that many vessels are subject to harsh treatment, and that, if captured, the loss to the merchant is far from being compensated even by a favorable decision of the prize court. The true remedy would be that the merchants and shipowners of Liverpool should refrain from this species of trade. It exposes innocent commerce to vexatious detention and search by American cruisers; it produces irritation and ill-will on the part of the population of the Northern States of America; it is contrary to the spirit of her Majesty's proclamation; and it exposes the British name to suspicions of bad faith, to which neither her Majesty's Government nor the great body of the nation are justly obnoxious. It is true indeed that supplies of arms and ammunition have been sent to the Federals, equally in contravention of that neutrality which her Majesty has proclaimed. It is true also that the Federals obtain more freely and more easily that of which they stand in need. But if the Confederates had command of the sea they would no doubt watch as vigilantly, and capture as readily, British vessels going to New York as the Federals now watch Charleston and capture vessels seeking to break the blockade. There can be no doubt that the watchfulness exercised by Federal cruisers to prevent supplies reaching the Confederates by sea will occasionally lead to vexatious visits of merchant ships not engaged in any pursuit to which the Federals can properly object. This, however, is an evil to which war on the ocean is liable to expose neutral commerce, and her Majesty's Government have done all they can fairly do; that is to say, they have urged the Federal Government to enjoin upon their naval officers greater caution in the exercise of their belligerent rights. Her Majesty's Government, having represented to the United States Government every case in which they were justified in interfering, have only further to observe that it is the duty of her Majesty's subjects to conform to her Majesty's proclamation, and abstain from furnishing to either of the belligerent parties any of the means of war which are forbidden to be furnished by that proclamation.

No further questions arose respecting the effectiveness of the blockade. Some correspondence took place between the governments of the United States and England relative to certain prizes which were captured, and to fitting out vessels in the latter country for the purpose of running the blockade, for which see *DIPLOMATIC CORRESPONDENCE AND UNITED STATES*.

BRAZIL, a vast empire of South America, is bounded on the E. and S. E. by the Atlantic Ocean, on the N. by Guiana and Venezuela, and on the W. and S. W. by Ecuador, Peru, Bolivia, Paraguay, the Argentine Republic, and the Republic of Uruguay. It has a coast line of upward of 3,700 miles. Its greatest diameter is, east to west, from Cape Augustin, S. lat. 8° 21', W. long. 84° 56', to the river Yavari, which separates it from Peru, 2,630 miles, and north to south, from Cape Orange, N. lat. 4° 28', W. long. 87° 27', to the river Tahim, 2,540 miles. Its total area is roughly estimated at 3,956,800 sq. m.

Politically, it is now divided into 20 provinces, the population of which, in 1856, together with the name of the capital and the number of senators and deputies elected by each, are exhibited in the following table:

PROVINCES.	Popula- tion.	Senators.	Deputies.	Capital.
Para.....	207,400	1	8	Para.
Maranhao.....	360,000	3	6	Maranhao.
Piahy.....	150,400	1	2	Oeiras.
Ceara.....	385,800	4	8	Aracate.
Rio Grande do Norte.....	190,000	1	2	Natal.
Parahiba.....	209,800	2	5	Parahiba.
Pernambuco.....	950,000	6	14	Pernambuco.
Alagoas.....	904,200	2	5	Porto Calvo.
Sergipe.....	183,600	2	4	Sergipe.
Bahia.....	1,100,000	7	14	Sao Salvador.
Espirito-Santo.....	500,000	1	2	Vitoria.
Rio de Janeiro.....	1,200,000	6	12	Janeiro.
St. Paulo.....	500,000	4	6	Santo Paulo.
Sta. Catharina.....	106,000	1	2	Sta. Catharina.
Rio Grande do Sul.....	201,800	3	6	S. Pedro do Sul.
Minas Geracs.....	1,300,000	10	20	Ouro Preto.
Matto Grosso.....	85,000	1	2	Cuyaba.
Goyaz.....	190,000	1	2	Goyaz.
Amazonas.....	42,600	1	1	
Parana.....	72,400	1	2	
Total.....	7,677,800	58	122	

Toward the close of the year 1862 a serious difficulty arose between the Governments of Brazil and Great Britain from the refusal of the Brazilian Government to admit certain claims which Mr. Christie, the British minister at Rio de Janeiro, had made. The facts, as far as can be ascertained, were as follows:

In June, 1861, the British consul at Rio Grande do Sul heard, that a Brazilian magistrate of Albardao, a wild and half peopled portion of the Brazilian coast in the province of Rio Grande do Sul, had mentioned in conversation that the dead bodies of Englishmen had been washed on shore near his house, but he denied that there had been any wreck. This led to an inquiry, the consul having reason to suspect that a British vessel had been wrecked on the coast, and that that wreck had taken place some days previously to the conversation in which the Brazilian magistrate had taken

part, but that no inquest had been held on the bodies, nor had any information been given to the authorities as to the wreck. The consul accordingly proceeded to the spot in company with a judicial officer and a small body of coast guards. On arriving there he went to the house of the magistrate, who was absent. His visit was not very well received, and in the house was found some portion of the cargo of the wrecked vessel, which evidently had not been in the sea, but had been removed from the vessel, and had not been damaged by sea water. On the following day the consul went to the coast and found the remains of an English vessel, the *Prince of Wales*. The sands were covered with the cargo, some portion of which was damaged by the sea, but a very large portion was not damaged at all. The trunks had been broken open and their contents plundered. He had heard that ten bodies of Englishmen had been found upon the coast, and he desired to see the bodies, but the inspector of the district resisted the attempt, and being at the head of a body of armed men, the consul was obliged to desist, and he returned to Rio de Janeiro. After some trouble he obtained from the authorities their aid in having the bodies brought to Rio de Janeiro, but at his own expense. Instead, however, of ten bodies being brought, there were only four, upon which an inquest was held. On further remonstrance an inquest was directed to be held on the remaining bodies, but no person from the consulate was present, and the persons appointed to carry on the inquest were a sub-delegate and the brother-in-law of the magistrate, who was suspected to have been a party to wrecking the vessel.

Application was made for redress, but it was not till September 18, 1861, that any steps were taken by the Brazilian Government. The compensation then offered not being deemed sufficient by the British Government, they demanded that further inquiry should be made. This request was not complied with till the month of August, 1862. Mr. Christie then demanded that a British officer should be present at the inquiry, but that was refused. Late in August the Brazilian Government announced that two of the minor officials had been dismissed for culpable neglect, but no steps were taken to punish the principal culprit.

This alleged outrage was the first cause of complaint. The second act complained of took place on June 7, 1862, just a year after the wreck at *Albardao*. It consisted in the arrest and detention for a night and a day of two of the officers and the chaplain of the British ship *Forte*. Mr. Christie's representation was, that the three had been dining ashore in the suburbs of Rio de Janeiro, and were quietly returning to their ships when stopped by the sentry on duty at a guard house near the beach; that on resisting their unprovoked detention, one of them was wounded by the soldier's musket, and they were locked up without having in the

least misconducted themselves. The Brazilian authorities replied to this representation, after examining witnesses—among them the English master of the hotel at which the gentlemen had dined—that the officers and chaplain had been drinking as well as dining; that they insulted the sentry and annoyed the passers-by; that they were not in uniform, and refused to give their names and rank; that they were locked up, in fact, for being drunk and disorderly, and were released after a detention that was not unreasonably long or offensive. Notwithstanding this explanation of the affair, Mr. Christie, acting upon authority from Lord Russell, demanded the dismissal of two officers, the further reprimand of two others, and the punishment of the sentinel.

In consequence of the refusal of the Brazilian Government to comply with the British demands, Mr. Christie, on Dec. 5, 1862, despatched three notes to the Brazilian Minister of Foreign Affairs, to which he demanded a definite reply by the 20th of the same month.

As these notes did not bring forward any new argument in support of the British demands, the Brazilian Government, in a note of December 29, after giving a detailed account of what had occurred, of the investigations that had been made, and of the explanations which had been offered to the British legation, adhered to its former refusal. While it referred the final settlement of the question to the British Government and the Brazilian legation at London, it protested energetically against having any responsibility in the case of the *Prince of Wales*, and peremptorily declined payment, declaring that if it should be forced to yield in the question of indemnification it would only pay the sum demanded by the British legation or the British Government under protest.

In reply to this note, Mr. Christie ordered a declaration to be posted at the doors of the British consulate, to the effect that, the Brazilian Government having refused to give satisfaction to Great Britain, Admiral Warren would be immediately instructed to retaliate by seizing Brazilian property. This order was promptly executed. At night, on December 30, the English war steamers *Stromboli* and *Curlew* quitted the bay of Rio. The preceding evening the telegraph had signalled the capture of a Brazilian vessel outside the bar by an English steamer. Popular indignation at this intelligence ran very high, and large numbers of excited but inoffensive groups collected in the streets. On Jan. 6, 1863, it transpired that the *Stromboli* had reëntered the bay during the past night, bringing news of the capture of five vessels, one of which was a steamer, their entire cargoes being valued at £30,000 sterling. The irritation of the people now became extreme. The entire population, with boundless enthusiasm, applauded the refusal of the ministry to comply with the demands of the British minister. The indignation manifested against England was intense, and caused the apprehen-

tion of a popular outbreak against the British residents. Foreigners as well as natives with perfect unanimity declared themselves strongly opposed to the proceedings of the English minister. Excited meetings were organized in the open street, and the speakers implored the people to make no reprisals upon English property, and to refrain from molesting English residents, but at the same time to encourage the Government to resist. The emperor and several of the cabinet ministers found it necessary to address the people, to urge them to remain quiet, and to trust to the Government the vindication of the national honor. Lists of volunteers were opened, and immediately filled; deputations were formed to congratulate the ministry upon its attitude, and liberally responded to by the citizens, some giving as much as £1,000. The shareholders of the bank demanded that a resolution should be passed not to discount the paper of English houses, and proclamations were issued, inviting the people to abstain henceforth from using any description of English goods. On January 6th the Brazilian Government, by the advice of the councils of state, determined to accept the new proposition of Mr. Christie, according to which the following arrangement was concluded: The prizes are to be restored. The Brazilian minister in London, if so required by the British Government, will pay, under protest, whatever sum may be demanded to the owners of the Prince of Wales. With respect to the treatment sustained by the officers of the Forte, it shall be submitted to the arbitration of the King of the Belgians to decide whether or not such treatment should be regarded as an outrage upon the honor of the British navy. Upon the receipt of this news in England, the extreme and summary measures adopted by the British Government were severely censured by the liberal press. Meetings of merchants, engaged in the Brazilian trade, expressed their disapprobation. The matter was brought up in the House of Commons, when Mr. Layard, in the name of the Government, admitted that Mr. Christie acted under instructions from the Government, and expressed the hope that the matter would be soon amicably settled.

Another collision toward the close of the year took place in the river Amazon between the Brazilian authorities and two vessels of war lately built in Great Britain for the Peruvian Government. Some time previous the Peruvian Government had entered into a contract with the Brazilian company, "Companhia de Navigacao e Commercio do Amazonas," for the conveyance of mails, &c., on the upper waters of the Amazon. For a year previous to the expiration of the contract payment was withheld by the Peruvian Government on one pretext or another, and, finally, it refused to pay at all, on the plea that verbal notice had been given to the Amazon company that the (written) contract was no longer in force. The Amazon company consequently instructed their

agent at Para, at the mouth of the Amazon, not to take any more cargo belonging to the Peruvian Government, and to give notice that after the end of the year no cargo destined for Peru would be taken on board the company's steamers. The Peruvian Government was thus put in great embarrassment, for by a convention existing between the Governments of Peru and Brazil it was distinctly stipulated that no goods shall be taken up the Amazon in Peruvian vessels until the limits of the two countries were mutually agreed upon. About the middle of October, 1862, the Peruvian war steamers Morona and Pastaza arrived at Para, and professed that they were going up the Amazon for the purpose of assisting in marking the boundaries between Peru and Brazil. To the surprise of the Brazilians, a few days subsequently, the Morona took in a general cargo, mounted her guns, and, in disregard of a formal intimation from the president of Para that she could not, without direct violation of the convention existing between the two countries, proceed on her voyage, the anchor was weighed, and the Morona steamed up the river, followed speedily by the Pastaza. The president of the province immediately sent after them a fast steamer, the Belem, belonging to the Amazon company, on board of which he placed two hundred artillerymen and some nine-pounder guns. The Belem overtook the Morona at a place called Gurupa, and her commander at once ordered the Morona to return to Para. This order being set at defiance the Belem proceeded to the fortress of Obidos, which she reached six hours before the Morona, so that when the latter arrived at Obidos the fortress fired two blank cartridges for her to bring to. In reply the Morona fired a shot, upon which the fortress fired eight shots at the Morona, and the latter replied with round shot and canister. No injury appears to have been done by this exchange of fire, and the Morona proceeded on her voyage. The Pastaza soon after leaving Para got ashore, but floated with the rising of the tide, and returned to Para. These events had created great excitement in Para, and the Brazilian Government had ordered several of their vessels of war to rendezvous at the mouth of the Amazon.

Brazil has been making of late great progress in civilization and material prosperity. Garibaldi, who was for some time clerk in an English house in Rio de Janeiro, built about the first ten miles of railroad ever constructed in Brazil. Since then other roads have been made; the demand for steamboats on the Amazon begins likewise to be supplied; docks were constructed and used at Rio de Janeiro in 1861; in 1862 the first ferry boat was taken to Rio de Janeiro from the United States. Particular attention is paid to the encouragement of European emigration, although the efforts of the Government have been thus far only partially successful. The most numerous emigrants come from Portugal and the Azore Islands, and they

devote themselves almost exclusively to commercial industry. Some forty thousand immigrants have also arrived from Germany and Switzerland, and established a number of colonies, of which the most important are those of Sao Leopoldo, in the Province of Rio Grande, and Donna Francisca, at Saint Catherine. The Swiss Confederation sent in 1861 a distinguished scholar, M. Tschudi, to examine thoroughly the condition of the colonists, and his report was in the main favorable. Some difficulty arose from the fact that a considerable number of German and Swiss emigrants were Protestants, and the laws of Brazil recognized only the Roman Catholic Church; but the Government has now guaranteed to all the Protestant immigrants freedom of religion, and even provides for the support of their ministers and teachers, churches, and schools, as soon as the number of colonists in any place has reached four hundred.

Of immense importance, especially for commerce, will be the opening of the Amazon, the largest river of the world, to which the Government is devoting great attention. A body of scientific men, provided with the finest instruments, have been employed by the Government for its exploration, and the result of this interesting investigation it is expected will ere long be published. The city of Para is already rapidly progressing. For ten miles up the river from Para the land on the banks appears to be a vast brick kiln, preparing bricks for the enlargement of the city. This city has undoubtedly a great future. It is the centre of the whole commerce of the valley, and the climate is of a healthy character. Close to the city spread the virgin forests. Sugar cane planted in the valley becomes perennial, and throughout its whole extent all the best medicinal plants in the world grow in profusion.

The Emperor of Brazil is very popular, and it is hoped that the progress of this vast empire, which seems to be destined to become one of the greatest of the world, may be uninterrupted and rapid.

**BRODIE, SIR BENJAMIN COLLINS**, baronet, D.C.L., F.R.S., sergeant-surgeon to the queen, an eminent English surgeon, born at Winterslaw, in Wiltshire, in June, 1788, died at Broomepark, Betchworth, Surrey, Oct. 21, 1862. He was the son of Rev. Peter Bellinger Brodie, a learned and able clergyman of the English Church, and received his early education under his father's care. At the age of 16 he was already a good classical scholar, and having a predilection for the study of medicine, he was sent in 1799 to London to commence his professional studies at the Hunterian School of Medicine in Windmill street. After a four years' course in that school he became a pupil of Mr., afterward Sir Everard Home, then one of the most distinguished surgeons in the metropolis, in 1803. In 1804, at the age of 21, he gave lectures on anatomy in St. George's Hos-

pital, and in 1808 became assistant surgeon of that hospital. In 1810 he received the Copley medal for two able papers in the "Philosophical Transactions," and the same year was appointed Croonian lecturer. In 1819 he was elected professor of anatomy and surgery to the Royal College of Surgeons, and in 1822 one of the principal surgeons of St. George's Hospital. In 1823, at the age of 40, he occupied the first rank in his profession. In 1830 he was called to attend George IV. in his last illness, and on the accession of William IV. was appointed sergeant-surgeon to the king. He was created a baronet in 1834. On the accession of Queen Victoria he was appointed sergeant-surgeon, and on her marriage surgeon to the Prince Consort. The Government also recognized his ability by placing him on important commissions relative to medical education, the public health, sanitary matters, &c. He was also professor of the Medico-chirurgical Society; president of the Royal College of Surgeons, member of the Council of the Royal Society, and later, its president, and corresponding member of the Institute of France. Oxford University conferred upon him the degree of D.O.L. in 1850. His practice was, as a whole, larger than that of any other British surgeon, though perhaps not equal in any one year to that of Sir Astley Cooper during two or three of his best years. For nearly 40 years it is said to have exceeded £12,000 per annum. Yet amid all his professional labors and cares, increased as they were in the later years of his life by impaired vision, he found time to prepare several works of great value on topics connected with his profession. The principal of these were "Lectures on Diseases of the Urinary Organs;" "Observations, Pathological and Surgical, on Diseases of the Joints" (both these have passed through numerous editions); "Physiological Researches," reprinted from the "Philosophical Transactions in 1851," and "Physiological Inquiries," first published in 1854. He was a skilful physician, and an admirable operator, profoundly versed in anatomy, and in the science as well as the practice of his profession, and withal a genial, generous, and accomplished gentleman.

**BUCKLE, HENRY THOMAS**, an English philosopher and historian, born at Lee, in Kent, Nov. 24, 1822, died in Damascus, Syria, May 28, 1862. His father was a wealthy London merchant, and he received an excellent early education under Dr. Holloway at Gordon House, Kentish Town. At the age of sixteen, when asked by his father to name his own reward for the diligent scholarship which had made him the first scholar of his class, he preferred the earnest request to be allowed henceforth to pursue his studies alone. His desire was granted, and thenceforth, with a rare determination and fixedness of purpose, his time was given wholly to earnest study, with the single recreation of games of chess, in which he won the reputation of being one of the best players in England. The death of his father occurring in

1840, he soon came into the possession of a large fortune, which enabled him to gratify his passion for books. Of these he made a very large and choice collection, and to an extent seldom equalled at his age, had made himself master of their contents. His extensive reading and devotion to study attracted the notice of such men as Hallam and Bunsen, who regarded him as a young man of great promise. The tendency of his mind and the drift of his studies had been from an early period toward the philosophy of history, and the result of his many years of labor finally took form in a proposed "History of Civilization." The first volume of this, consisting only of an elaborate introduction to the "History of Civilization in England," appeared in 1857, and was republished the next year in this country; a second volume, also introductory in its nature, and devoted to the developments of civilization in Spain and Scotland, was published in 1861, and a third, in which he was to review the civilization of Germany and the United States, was in progress. These were all preliminary to his treatment of the subject of the "History of Civilization in England," of which the greater part was said to be ready for publication. He had also published in "Fraser's Magazine" two essays, republished since his death in this country, on "Liberty," and on the "Influence of Women." The theory on which his historical works were based called forth strong and severe animadversion, and was hardly accepted even by his most intimate friends and admirers; but while many of the objectionable positions in his works were attributed to his isolation as a student, and his one-sided views of humanity, he was unquestionably but partially understood, and greatly misrepresented by his critics. A more free and extended commingling with his fellow men, it was thought, would have greatly modified his theories, and brought his really reverent spirit to a better understanding of the "ways of God with man." The literary merits of his works are very great: they give evidence of vast research without pedantic display, and the style in its lucidity and fascination compares favorably with that of the great English historian Macaulay.

Mr. Buckle had seriously overworked himself in the preparation of his second volume for the press, and after its publication suffered from illness for some months. In October, 1861, he left England, accompanied by two boys, sons of a friend, to spend the winter on the Nile. In March, his health being improved, he left Cairo, with Mr. J. S. Stuart Glennie, for a tour through Sinai, Petra, and Palestine. The fatigues of a horseback journey through the latter region, led to his serious illness for about ten days at Nazareth; recovering partially he pushed on to Sidon, and thence by the easiest route to Damascus, where he was attacked with typhus fever, and died after about ten days' illness.

**BUILDING MATERIALS.** The very marked decay already taking place upon the surface

of the stone used in building, not many years since, the new palace at Westminster, London—the edifice containing the new houses of parliament—having led to the appointment of a committee to consider the subject of the causes of decay in building stones and the possibility of preventing it, the report of that committee has not only furnished some important information upon the topics in question, but has served to elicit further discussion in England and to some extent in this country. The stone used in construction of the palace—a magnesian limestone—was mainly procured from the quarries of Anston; a portion, however, in view of its reputation for durability, was taken from the ancient quarries at Mansfield Woodhouse. The committee of investigation just referred to, appointed by an order of the House of Commons, consisted of Sir R. I. Murchison; Geo. Godwin, and M. Digby Wyatt, Vice-Presidents of the Royal Institute of British Architects; D. T. Ansted and James Tennant, Professors of Geology; A. W. Hofmann, Edward Frankland, and F. A. Abel, Professors of Chemistry, and others: their report is dated August 1, 1861, and is based upon results elicited by an examination of 77 communications submitted, and of 81 witnesses—13 meetings, irrespective of those of sub-committees, having been held for the purpose. The more important statements in reference to the four points of inquiry specified in the act of appointment, as condensed from the reply of the committee, are as follows:

"I. The extent and position of the decay." This began to appear in portions of the palace first built, and about 7 years after their execution; yet in some of the most recent parts it is now as obvious as in any others. In the parts toward the Thames, and in those fronting on the approaches to Westminster Bridge, the decay is much greatest in the lower portions of the wall; in some exposed positions where it was looked for, it is extremely slight; but in the inner courts, which are much sheltered, it is considerable, and perhaps the worst specimen is one of the parts most sheltered of all—an archway leading to the reporters' gallery, near the entrance to Westminster Hall. Thus, the material appears most liable to decay in damp and confined situations. The actual disintegration and discoloration of the stone in the affected portions are already considerable, suggesting deeper inroads into the material than are at first apparent; but though the disfigurement, marking the plane surfaces more than the carved work, is already serious, it is inferred that the stability of the structure is not at present endangered.

"II. The causes to which the decay is attributable, taking into consideration the composition of the stone, and the influence exerted upon it by moisture, and by the acids diffused in the London atmosphere." It was previously known to some contractors that some layers of the Anston stone were liable to decomposition; and though no inspector of the material



was appointed, some of the stone was rejected by the builders themselves. The sub-committee, consisting of the three chemists already named, make a division of building stones into 2 classes: 1, those of materials not easily acted on by acids; as granites, porphyries, and serpentines; 2, those of materials partially or entirely subject to ready action of acids, among which limestones, dolomites, and certain sandstones containing carbonate of lime as cementing material, must be classed. Among analyses of several varieties of dolomite, quoted in illustration of the composition of the stone in question, that of the North Anston quarry gave: carbonate of lime, 54.89 per cent.; carbonate of magnesia, 42.07; protoxide of iron, 0.49; peroxide of iron, 0.24; protoxide of manganese, *a trace*; silica, 0.56; water, 0.51. Not merely chemical composition, however, but physical condition also, goes to determine actual durability; thus, marble, a crystalline carbonate of lime, is much less subject to influence of acids than chalk, an amorphous one. Now, in the dolomitic limestone of the new houses of Parliament, while the same block of small dimensions is often greatly disintegrated in one part, and wholly untouched in another, analysis fails to show a difference in the chemical nature of the two parts; so that the cause must really exist in the state of aggregation of the material. Among the agents in the atmosphere that may attack building stones, are: 1. *Oxygen*, but only in case of those rare sorts containing sulphurets of iron, or the protoxides of iron and manganese, all of which are liable to oxidation. 2. *Carbonic acid and water*: carbonic acid in presence of water proves a powerful solvent, decomposing in time the most indestructible rocks. The acid transforms the insoluble earthy carbonates of lime and magnesia in the stones containing these into soluble bicarbonates; the water first serving as vehicle to introduce the acid, and then as solvent to wash away the products of its action. The removal in like manner of the alkaline bases from silicious rocks, leaves the silica in more or less friable condition. Besides, the committee think that water exerts a gradual disintegrating action near to the surface of stones, by the expansion occurring in its volume, upon its freezing within the interstices of the material. 3. *Nitric acid*: this is now known to be an almost constant, probably a normal, constituent of the air; but though it must assist in destroying calcareous and magnesian stones, its minute quantity renders its action scarcely worthy of notice. 4. *Sulphur acids*: these in towns, especially where much coal is burned, become quite appreciable. Dr. Angus Smith found in the air of parts of Manchester one part sulphuric acid in 100,000, and in the centre of the town, 25 parts in 100,000 of air. The composition and structure as well as the situation of the stone of the new houses of Parliament render it subject to action of all the agents now named, save oxygen. The chief agents in

the decay are doubtless carbonic and sulphuric acids, with water; the action of the last named acid being indicated even by a marked efflorescence of sulphate of magnesia on the face of many stones from which exfoliation is taking place, while its effects will be not only due to solution of the lime and magnesia of the stone, but also to the forming of crystals of sulphate of magnesia within the pores, and which like those of ice will act to disrupt and remove the superficial parts of the material.

"III. The best means of preserving the stone from further injury." The sub-committee, already mentioned, begin their report on this head by declaring that, among the many processes for preservation that have been brought to their notice, there is not one which they at present feel justified in definitely recommending as a preservative, either for general or local application. Having devoted 5 days exclusively to the study practically of one process, Ransome's—presently to be described—they declare themselves unable to elaborate even this sufficiently to warrant them in expressing a final opinion as to its merits. The processes they had examined could be divided generally into: 1, those for permanent, and 2, those for temporary protection. In both these classes they summarily dismiss some of the proposed methods, as applicable only to stones before being placed in a building, or as showing misapprehension of the real problem to be solved—among these being such as boiling in a mixture of pitch or resin and oil; covering with a semifluid mixture of silica and sulphur, the latter not only oxidizable but highly inflammable; and even the offer to protect the walls galvanically by coating with sulphate of lead, and putting this in connection with plates of zinc; and again, to check the decay by first producing fermentation over the surface, in a coating of some organic and fermentable substance. The more probably applicable of the permanent processes, they classify under 5 heads, namely: the application, 1, of silicates of the alkalies, in various degrees of concentration; 2, of silicates, in conjunction with various saline compounds, intended to produce double decomposition; 3, of hydrofluoric, or hydrofluosilicic acid, or their saline compounds; 4, of phosphoric acid, and acid phosphates; 5, of solutions of the alkaline earths, or their bicarbonates, in water. As to these, however, they advise nothing further than to apply, to portions of the palace wall actually decaying, the best representatives of the three classes last named, as an experimental test of their value, deeming that experiments already in progress with some of those in the first two subdivisions will, in the course of a few years, determine the question of their applicability. Of processes for temporary protection they recommend for trial on some affected parts of the wall only the solutions in volatile solvents of some of the most unchangeable of organic bodies, as paraffine, beeswax,

or the more permanent gums and resins. Finally, they think that only the test of some years of experiment and actual use can decide the questions of the actual or comparative merits of these various processes. In these views the general committee coincide; and they accordingly recommend no general coating, painting, oiling, or washing of the building, but only precautions—though by what means they scarcely make clear—to arrest decay where it actually commences, or in the worst cases the cutting out of the decaying stone, until more definite knowledge shall supply a remedy on which full reliance can be placed.

“IV. The qualities of the stones to be recommended for future use in public buildings in London.” This head may here be briefly disposed of; since, the London atmosphere being among the most destructive to which building materials can be exposed, and the air of most cities in this country being much more dry and less corroding, the interest in this part of the subject must be for American architects mainly that of comparison. The committee condemn the magnesian limestones as an unsafe material for public buildings in London. The Portland stone, not so hard as the Anston, and yet with a power of withstanding the London atmosphere shown in many buildings from the date of St. Paul’s downward, they fully recommend; though even with this, a careful selection at the quarries is necessary. The carbonates of lime used for buildings in the comparatively pure atmosphere of Paris, and where wood is largely used as fuel, also suffer decay, which, thus far, the French architects and chemists appear to have been no more successful than others in preventing or arresting. The committee close by recommending a persevering trial of the various probably valuable preservative materials and agents, expressing a belief that a large portion of the stone of the new palace is very durable, and that a remedy sufficing to arrest or control the decay in the affected portion will soon be found.—The full report may be consulted in the “London Builder,” No. 974; and “Journal of the Franklin Institute,” Phila., Jan. 1862.

In a paper read before the Architectural Association (London “Mechanics’ Magazine,” February, 1862), Mr. A. H. Church laid down certain principles as likely to be practically effective in accomplishing the preservation of stone, among them the following: 1, Any process, to be practically useful, must be easy of application, and moderate in cost; 2, It must render absorbent stone less porous, and counteract also the influence of injurious bodies in the air; 3, It must consolidate stones, the particles of which are loosely aggregated, and harden such as are easily abraded by mechanical means; 4, It must not materially change the color, surface, or texture of the stone; 5, The protecting material must not remain as a film, but must penetrate the material; not, however,

contracting the surface, or otherwise separating particles from the stone; 6, The material must be less soluble in water and less subject to atmospheric agents than the material of the stone; 7, Its application must leave no soluble, and especially no efflorescent or crystallizing salt, as one of its products, in the surface or substance of the stone. As a result of some of the so called preservative processes, a sulphate of soda or of magnesia is formed in the superficial parts of the stone, which effloresces upon the surface; and it is curious to note upon the summit of each hair-like crystal a minute fragment of stone, torn off and carried forward by the force of the crystallization. Again, when a strong aqueous solution of silica is applied to chalk or a soft limestone, the silica glutinizes on the surface; the film formed scales off, and the scales bring away with them adherent particles of the chalk or stone upon their inner surface. The principles and remarks here offered have doubtless a reference to Mr. Church’s process of preservation, presently to be named.

At a stated meeting of the members of the Franklin Institute, Philadelphia, December 19, 1861, Mr. A. L. Fleury read a paper on the subject of preserving building stone by applying a pure aqueous solution of silica, adding other uses of the same solution. He first referred to the very elaborate and quite exhaustive paper by Mr. J. M. Ordway, on “Water Glass” (“American Journal of Science,” Sept. and Nov. 1861, and Jan. 1862), or the various forms of soluble alkaline silicates, originally investigated by Fuchs, Kuhlmann, Liebig, and others. For these alkaline silicates he would substitute the aqueous solution just mentioned; a suggestion made also in the same year by Mr. W. Crookes, editor of the “Chemical News.” Mr. Fleury proceeds to quote from the last named journal, No. 100, giving several modes of preparing the soluble silica. The difficulty which besets many of the processes of silicification is, that along with the needful silica, so much superfluous, and indeed injurious matter is often introduced, that the valuable qualities of the silica are in a great measure counteracted. Of the four modes given for preparing the pure solution, which at least has the merit of excluding these useless or hurtful intermixtures, we name the two which appear to prove most satisfactory: 1, By dissolving pure sulphide of silicium in water; sulphuretted hydrogen is given off, the silicium is oxidized, and the resulting silica remains completely dissolved, in such proportion, moreover, that the liquid gelatinizes upon attempting to evaporate it. 2, By Prof. Graham’s new method of *Dialysis*. (See CHEMISTRY.) In this, a solution of silicate of soda, supersaturated with hydrochloric acid, is placed on one side of a parchment paper septum, pure water being on the other side; in a few days the hydrochloric acid and chloride of sodium will be found to have completely passed through the diaphragm, leaving the silica in aqueous solution, and so pure that acid

nitrate of silver fails to detect chlorine in the liquid. This solution remains fluid for some days, but it ultimately gelatinizes. Of these two methods, the former gives the silicious solution in the greater strength. When such solution, thus prepared, is applied with a clean brush once or oftener over the surface of chalk or dolomite, Mr. Crookes states that a process of hardening occurs, which goes on increasing for several days, while, owing to the depth of penetration, and to there being no soluble or efflorescent compounds to be removed, there appears a strong probability of permanent protection by means of this silicious impregnation to the stones so treated. (It must be added, from other sources, that upon actual test of the pure solution of silica for preserving stone, made in England, it was found that the solution too frequently gelatinized mainly on the surface of the material, drying and scaling off, and chipping the surface in so doing. It cannot, therefore, be recommended, as is done by Mr. Fleury, for preserving building stones, and more especially not for decaying monuments. Of the other uses suggested by the writer named, and which will be mentioned, some may prove of real practicability and value.)

The first of the proposed applications of the hydrated silica being set aside, among the others are, briefly, the following: 2, The formation, by admixture in due proportions with other cheap materials, as lime, clay, sand, &c., of artificial building and other stones; 3, The application of the solution to wood, so as to render it comparatively indestructible, and fire and water proof; 4, The mixing of the solution with certain colors used by painters, and forming silicated colors, such as have lately been employed by Kaulbach and by many other painters of frescoes, German, French, and English, and which (chemical analysis showing that the frescoes at Herculaneum and Pompeii were of such character) appear to have the quality of resisting the change usually caused by time; 5, The formation, by mixture with certain materials, of a durable artificial marble, susceptible of beautifully variegated coloration; 6, Combination with certain organic substances to form many articles for which a plastic material or composition is suitable, as certain parts of machinery, furniture, &c. ("Journal of the Franklin Institute," January, 1862.)

Messrs. Bartlett, Bros. & Co., of Camden Town, Eng., propose ("Chem. News", No. 101) as a preservative material a combination of silicate and aluminate of potash, the latter prepared from a fused compound of alumina and potash, and dissolving readily in water, with not more than two per cent. of free potash. When silicate of potash, sp. gr. 1.250, and this aluminate of potash, sp. gr. 1.200, are mixed, instantaneous decomposition takes place, the result a solid mass, consisting of silicate of alumina, and some free potash. The mass hardens with extraordinary rapidity. The solutions being of somewhat less specific gravity, so that, mix-

ed, they shall be of sp. gr. 1.150, the result of the combination lasts as a solution about 10 hours; but formed at or evaporated to about sp. gr. 1.200, it solidifies immediately. The product of the combination of the materials named, is declared to resist dilute sulphuric and hydrochloric acids.

The defect referred to above in the process suggested by Mr. Crookes, with pure solution of silica, Mr. Church thinks he has obviated by his method, which consists in applying along with the silica solution, usually first, but sometimes second, a solution of baryta (oxide of barium). The result he states to be the deposition within the interstices of the stone so treated of the insoluble and unalterable silicate of baryta, no other materials accompanying these, so that no soluble or otherwise injurious salt can be formed. By this process he considers that porous stones are necessarily made harder, and less subject to atmospheric influence; that brick, terra cotta, &c., may be made nearly water-proof; and that articles moulded from plaster of Paris are greatly improved in appearance and durability. The application, as proposed by others, of a silicate of soda and chloride of barium, results in production of silicate of baryta and chloride of sodium, the latter of which, washing out by rain, Mr. Church concludes, must injure the stone in respect to durability and appearance.

The process of Mr. Frederick Ransome, however, involving a principle nearly similar to that just stated, has received high commendation, and, among other authorities, by Prof. Ansted before the recent meeting of the British Association. Ransome's process consists in a deposit or formation within the substance of stones sufficiently porous, and whether natural or artificial, of a silicate of lime. The absorbent block or mass is first saturated, so far as may be, with a solution of silicate of soda applied to the surface, when this is followed with an application of solution of chloride of calcium: as the latter penetrates so as to come in contact with the former substance, a double decomposition takes place, the results being an insoluble silicate of lime, and a soluble chloride of sodium, the latter of which can be mainly washed away at once, or left to be removed gradually. Mr. Ransome formed in moulds small blocks of sand wet together by applying the liquid silicate of soda, and then hardened these by dipping them in the solution of chloride of calcium. The result was the formation, almost instantaneously, of a perfectly compact, hard, and apparently durable solid. In this and other ways, the inventor had employed the process in preparing artificial stones. Some of these are already in use upon the Metropolitan Railway. They are cheap, can be made on the spot where needed, of almost any rubbish or material at hand, and of any desired form and size. A bar of one of these artificial stones, 4 square inches in section, and over 8 inches between supports, sustained 2,122 lbs.;

like bars of Portland stone broke at 750 lbs.; of Caen stone, at 780 lbs. The cohesion or tensile strength of a bar, sectional surface  $5\frac{1}{2}$  square inches, weights being suspended from it and increased, was found equal to 1,980 lbs.; while Caen stone broke at 768 lbs., and Portland at 1,104 lbs. A cube of 4 inches sustained 30 tons pressure before crushing. These stones, however, were all recently made, and time alone can determine the question of their durability. Dr. Frankland found that the finished stone (of course after washing) still contained chloride of sodium, but he judges that this remnant is extractable without injury to the tenacity of the mass; and although it must obviously leave the stone more porous in time than at the first, he considers that this effect will be more than offset by the well-known tendency of the binding material, silicate of lime, to become more crystalline and so harder by age; so that these artificial stones may yet be found to surpass in durability any natural ones, unless it be the material quarried from the primary rocks.

Prof. Jas. Thomson read before the British Association a paper on the "Disintegration of Stones exposed in Buildings and otherwise to Atmospheric Influences," in which, setting out with the declaration that he would not be understood as assigning any single cause for the decay of building stones, he endeavored to show the fact of an important mode of such decay, hitherto overlooked. 1. He urges that certain cases of disintegration frequently observed, are not to be referred to the softening or weakening of the stone by dissolving away or chemical alterations of portions of it, but are instances in which the crumbling is to be attributed to a disruptive force exerted by certain crystalline matters in the act of solidifying in the pores or cavities of the mass, and from liquids permeating it. 2. That in such cases, the crumbling away of the stones, when not such as is caused by freezing of water in the pores, usually occurs in the greatest degree at places to which, by joint agencies of moisture and evaporation, saline substances existing in the stones are brought and left to crystallize. 3. That the solidifying of crystalline matters in porous stones, whether it be of ice from freezing of water, or of crystals of salts from their solutions, usually produces disintegration, not as commonly supposed, by expansion of the total volume of the liquid and the crystals jointly, occasioning a fluid pressure in the pores, but on the contrary, as a consequence of the natural and well known tendency of crystals to increase in size when in contact with a liquid that can still deposit in the solid state the same substance as that composing them—this growth in size still going on, even though, to allow of it, the crystals must push out of their way the porous walls of the cavity they are in, and even though it must be from liquids permeating these walls that the crystals receive the materials for their increase.

A patent has been taken out by Mr. L. Standfast, of London, for a composition of burnt clay, iron dust, brick dust, gravel, lime, and sand, mixed with hemp and hair, so as to form a cement, to be laid up in a suitable frame to constitute the walls of houses; such walls when dry being solid, instead of being composed of many small blocks. This application of gravel cement for building is similar to the concrete of gravel and mortar already in use for constructing the walls of houses, in some parts of the United States.

Of a valuable series of papers on "Hydraulic Engineering," by Mr. Samuel McElroy, C. E., in the "Jour. of the Franklin Institute," 1862, those in the numbers for May, June, and July, treat of "Reservoir Construction," its history theory, and practice, including the subjects of concretes, masonry, &c.; those in Nos. for September and October, of "Distribution." In the same journal, March, 1862, will be found an extract from a paper on the "Concrete used in the late Extension of the London Docks," by George Robertson, C. E. The highly special character of the branch of construction here involved, would render an abstract at length inappropriate in this place.

The factitious sorts of wood, as those produced by mixing fine saw dust of different natural woods with glue or other cementitious matter, and which are therefore generally obtained in a plastic state, and at once compacted and shaped by compressing in moulds, have become somewhat familiarly known; and thus far they have been employed rather for the manufacture of small articles than for building. Among the best of these is, doubtless, that of M. Ladry, formed by mixing sawdust with bullock's blood, and compressing. Another product of the sort, very recently invented in France, appears to have attracted still more attention: it is made of sawdust alone, heated to a high temperature, and in such state subjected to enormous pressure—600 tons, it appears, to the square foot; and while thus acquiring a compactness and hardness exceeding those of wood, it has a very fine texture, is readily moulded in forming it, and is unchangeable by the atmosphere. It is known as durable wood (*bois duré*).

The greatly diminished period of time during which ships are now built being found to result in an injurious increase of the tendency of their timbers to different forms of decay, in consequence of their becoming less thoroughly seasoned on the stocks, M. de Lapparent has within little more than a year past proposed, as a means of preserving the timbers, to carbonize their surfaces to a very slight depth, usually perhaps not exceeding about  $\frac{1}{16}$  of an inch, by directing upon the surface of the wood a jet of some inflammable gas in the state of ignition. A quite uniform carbonization of the surface can thus be secured; and the resulting coating, it is anticipated, will prove quite impervious to air and moisture. The process, the

expense of which needs not exceed about 10 cents to the square yard, has lately been tried at Cherbourg; and it is thus far regarded as proving completely successful.

The following application for prevention of the rotting of wood, especially suitable for fence posts, piles, and the materials of various wet constructions, is recommended, in a late number of Dingler's "Polytechnic Journal," as superior in view of its economy, and its impermeability to water, as well as of the great hardness it assumes: Take 50 parts of rosin, 40 of finely powdered chalk, 300 parts (or less) of fine white sharp sand, 4 parts of linseed oil, 1 of native red oxide of copper, and 1 of sulphuric acid. First heat the rosin, chalk, sand, and oil, in an iron boiler; then add the oxide, and with care, the acid: stir the composition carefully, and apply the coat while it is still hot. If it be not liquid enough, add a little more oil. This coating, when cold and dried, forms a varnish which is as hard as stone.

To the many processes in use for the treatment of wood with a view to render it more durable, and incidentally also less inflammable, that recently patented by T. Cobley, of Meerholz, Hesse, promises to add another. In this, a strong solution of potash, baryta, lime, strontia, or any of their salts, is by action of a pump forced into the pores of the timber, placed within a close iron vessel. After this operation, the liquid is run off from the timber, and hydrofluo-silicic acid is forced in; the latter, uniting with the salt in the timber, forms with it

an insoluble compound; and the wood is said to be in consequence rendered quite unflammable.

In conclusion, for the year, of this subject of building materials, it may be proper—since, although the American climate is less severe on the materials of edifices than is that of some European countries, the actual decay of building stones is even here considerable, and the subject therefore one of practical importance—to express a regret that persons who are in this country also conversant with facts respecting the comparative decay and durability of the materials employed in our public and private buildings, or those making investigations and inventions in connection with such materials, do not more frequently communicate their results to the scientific journals, in which they would be rendered accessible, and could become of general utility. The continually increasing employment among us of iron in the construction of buildings, it is true, substitutes for a part of our subject the consideration of the qualities and working of that metal. But the marbles, sandstones, granites, &c., will still continue, as well as bricks and various woods, to be largely used for building; and the question of real economy, as well as in certain instances those of beauty in time, and of the interest that is sure to connect itself with structures very long preserved, render a particular investigation of the comparative durability and unchangeableness of these various materials in the climates of our country a work greatly to be desired.

## C

**CALIFORNIA.** One of the Pacific States of the Union, first settled in 1769, ceded to the United States, by Mexico, in 1848, and admitted into the Union as a State in 1850. Its capital is Sacramento. The area of the State is 188,982 square miles, and its population in 1860 was 379,994, of whom 23,848 were Chinese and Mexican half-breeds, and 14,555 Indians.

The Governor of the State to December, 1863, is Leland Stanford, whose official residence is at Sacramento. The Secretary of State, whose term of office expires at the same time, is William H. Weeks, of Sacramento. The governor was elected in September, 1861. He received 56,086 votes, the Union Democratic candidate, J. Conness, having 30,944, and the Breckinridge Democratic candidate, J. R. McConnell, 32,751. Stanford's plurality was, therefore, 23,285. In 1862 the only State officer elected was a Superintendent of Public Instruction, and John Sweet, the Republican candidate, was elected, receiving 51,288 votes, while Stevenson, the Union Democratic candidate, had 21,514, and Fitzgerald, the Regular Democratic candidate, had 15,817. The Senate stands, 32 Republicans, 4 Union Democrats,

4 Regular Democrats. The House, Republicans 63, Union Democrats 10, Regular Democrats 7.

The Legislature of 1861, believing certain amendments to the constitution of the State required, passed a bill proposing amendments to articles 4, 5, 6 and 9. According to the Constitution these proposed amendments were to be passed upon by the next Legislature, and if adopted by them submitted to the people for their sanction. The amendment to section 9, which extended the term of office from three to four years, was adopted, and, being submitted to the people, received their sanction, but the amendments to the other sections were modified by the Legislature of 1862, and, though sanctioned in their modified form by the people, the irregularity of their modification, in the opinion of the highest legal authorities, rendered them void.

The message of Governor Stanford, sent to the Legislature January 5, 1863, reviews the financial condition of the State. The total indebtedness of the State is \$5,579,284.76. The financial year (or, rather the financial period, for there were but ten months and twenty days,

vis, from January 10 to December 1, 1862, embraced in the governor's statement) commenced with a floating debt against the General Fund of \$585,603.93, and the previous administration had received \$251,705.34 of the revenues of 1862, and applied the amount on the expenses of 1861. The total revenues of 1862 were \$929,334.34, less this sum of \$251,705.34 anticipated, leaving only \$577,629 of actual funds to meet the current expenditure. The expenses of the State from January 10 to December 1, 1862, were \$788,117.76, of which \$455,057.70 are yet unpaid. The governor recommends the levying of a tax of twenty-three cents on the \$100 to meet this floating indebtedness and place the State on a cash basis. Some measure, he thinks, should also be adopted to obviate constitutional objections against taxing the Chinese. He also recommends the organization, arming, and equipment of an efficient militia force in the State, and the adoption of a provision allowing volunteers in the army to vote. He suggests the propriety of gathering all the Indians in the State upon one large reservation, where they could be more easily guarded, and rendered far more comfortable, while the citizens would be protected from their hostile incursions. The State prison, he says, is insecure, and not in any respect reformatory. He recommends a system of solitary confinement. There are 585 convicts, and the average cost to the State of their support is eighty-four cents per week. On the 22d of July, 1862, 150 of the convicts escaped, and in the pursuit for their recapture three were killed and twenty-two wounded. At the close of the year sixteen of the number were still at large. The orphan asylums and the Deaf, Dumb and Blind Asylums at San Francisco were well managed, and deserving of aid from the Legislature. The State Reform School at Marysville is a very costly institution to the State, and the good it accomplishes is not commensurate with its cost. The care of an average number of about ten boys costs the State as much as the care of two hundred convicts at San Quentin. The governor suggests that an arrangement may be effected to place the boys in the Reform School at San Francisco (a city institution). The Insane Asylum is not in a satisfactory condition. It needs more room, more buildings and better management. The school fund lands and the receipts from the sale of portions of them should be carefully guarded and sacredly applied to the purposes of education. Seven millions of acres of the lands granted by the General Government are devoted to educational purposes. The Swamp Land Commissioners report that they have established the claim of the State to 485,252 acres of swamp lands, all of which are susceptible of permanent reclamation. The governor recommends the Legislature to enlarge the list of bounties for home products.

Congress, in 1861, in organizing the new

territory of Nevada, bestowed upon it some land included within the lines of the State of California, providing, however, that such lands should not enure to the new territory until the assent of California had been given to their surrender. The east line of California, it now appears, had never been carefully and accurately surveyed, and it was not possible to ascertain, without a survey, what portion already belonged to the territory and what to California. Governor Stanford urged the importance of an immediate survey, and the difficulties which have since occurred (in February, 1863) in regard to the boundary show its necessity.

*Floods.*—Mention was made in the *ANNUAL CYCLOPEDIA* for 1861 of extensive floods which desolated the Sacramento Valley in December, 1861; the continuous rainfall which followed caused still more extensive and disastrous floods in January, 1862, which attained their greatest height on the 24th of that month, and laid waste the greater part of the Sacramento and San Joaquin valleys. Seriously destructive as these floods were, and large as was the amount of property they destroyed, they were not without their partial compensations. The river beds, when again bare, were found to contain large amounts of gold, new placers were laid open, and the mining interests profited largely by the incursion of the waters.

*Mines and Mining.*—The year 1862 was one of great excitement among the mining population of California. The gold mines of the Cariboo region in British Columbia, and those of the Salmon river, the Nez Perces and the John Day and Powder rivers in Washington Territory and Oregon attracted the attention of the miners, and led to an extensive emigration in the early part of the year, and to these was added intelligence of a large and profitable yield in the mines on the Colorado river in Arizona. The new and constantly multiplying discoveries of silver in Nevada caused an additional excitement during the later summer and autumnal months, and from September to the close of the year new companies, many of them with large capital, were formed daily to prosecute silver mining. The gold mines in the vicinity of Grasshopper Creek, near the boundary of Dakota, discovered in July or August, 1862, attracted a considerable emigration thither in the autumn.

The magnitude of the copper deposits and the richness of the ore have led to the extensive and profitable development of the copper mines during the year. There are two very extensive beds of the ore at remote points: one at Copperopolis and its vicinity, in Calaveras county, near the centre of the State, and on the slopes of the Sierra Nevada; the other in Del Norte county, in the extreme north west of the State, west of the coast range, and only eighteen miles from the port of Crescent City. The Calaveras county mines are said to yield over \$60 worth of copper ore to the ton, and

the lodes in Del Norte county from 25 to 80 per cent of pure copper. The recently opened quicksilver mines are also yielding largely.

*Agricultural Products.*—The richness of the virgin soil of California is such that all trees, shrubs and grains which can withstand the long dry season by sending their roots downward below the hard crust which forms on the surface in the summer months, yield most profusely, and the fruits and root crops are of such dimensions as are entirely unknown elsewhere. A pear grown in the orchard of E. L. Beard, Esq., at San Jose Mission, in the summer and autumn of 1862, was exhibited in New York city in January and February, 1863. It was twenty inches in circumference one way, and sixteen inches the other, and weighed on its arrival three pounds seven ounces. Other fruits attain to similar gigantic dimensions, and yet retain their fine flavor. The potatoes, beets, turnips and other root crops are of extraordinary size and excellence. The wheat of California contains a very large amount of gluten, rendering it more nutritious than that of the wheat growing States east of the Rocky Mountains, and requiring a different treatment to make bread from it. The grape is largely cultivated, and the California wines are attaining a good reputation in the eastern markets. Cotton has been tested, but is not likely to prove a profitable crop, as it does not well endure the drought, and requires, especially at the time of the opening of the boll, an amount of moisture rarely present at that season in the California atmosphere.

The amount of treasure received at San Francisco in 1862 was \$49,375,462, and the amount shipped from that port \$42,561,761. The exports of California produce, other than treasure, from the same port during the year amounted to \$6,211,788, which included wheat and flour, equivalent to over 400,000 barrels of flour and 22,615 bales of wool. The entire value of the produce of the vineyards of the State was given at \$5,050,000. The amount of quicksilver produced exceeded two millions of dollars. During the year the tonnage of vessels which arrived at the port of San Francisco was 634,670 tons, and 497,345 tons were cleared from the port in the same time. The freight money paid on the cargoes of foreign and eastern ships was \$3,496,978. During the year 27,861 persons arrived in San Francisco by sea, of whom 8,188 were Chinese, and 11,711 left the country, of whom 2,795 were Chinese. The net gain of the population by seaward immigration at that port was, consequently, 16,150.

The population of the city of San Francisco, stated in the census of 1860 as 56,802, has greatly increased since that time. A census taken in the autumn of 1862 gives the whole population of the city as 91,825. Of these 32,000 were males over twenty-one, and 17,500 females over eighteen. The number of Chinese was 3,250; of other foreigners 4,200, and of colored persons 1,875.

**CANNING**, Right Hon. CHARLES JOHN, Earl, K. G., an English statesman and late viceroy of India, born Dec. 14, 1812, at Gloucester Lodge, Brompton, died in Grosvenor Square, London, June 17, 1862. Earl Canning was the youngest child and only surviving son of the distinguished statesman Right Hon. George Canning, and was educated at Christ Church, Oxford, where he obtained in 1833 the high honor of first class in classics and second class in mathematics. He was elected to the House of Commons for Warwick in August, 1836, and on the death of his mother in March, 1837, was transferred to the House of Lords as Viscount Canning. In 1841, he was appointed under Secretary of State for Foreign Affairs under the late Earl of Aberdeen in the Peel administration, and in January, 1842, was made Commissioner of Woods, &c. At the breaking up of that administration, in July, 1846, he retired from office, and was not a member of the cabinet again till 1853, when he accepted the office of postmaster general, in the Aberdeen administration. In July, 1855, he was selected as successor to the late Marquis Dalhousie as governor general of India. In little more than a year after his arrival in India, the mutiny broke out, and his energy and statesmanship were severely tested. Some of his measures were at the time severely censured, and one (the attempted confiscation of the lands of the talookdars of Oude) was vetoed by the home government. He, however, proceeded to carry out his plan for the pacification of India in a conciliatory spirit, and accomplished it with such success that in April, 1859, he received the thanks of both houses of parliament for his eminent civil services during the mutiny, and the queen, in token of her approbation, made him an extra civil grand cross of the order of the Bath, and in May, 1859, created him an earl, and in May, 1862, conferred upon him the order of the Garter. His countess, eldest daughter of the late Lord Stuart de Rothesay, died in Calcutta, Nov. 18, 1861, and leaving no issue the title became extinct.

**CHEMISTRY.** The recent progress of this science, and mainly for the past year, in certain leading features both of theory and practice, is presented under the following subdivisions:

I. **ELEMENTS.** *Cæsium.*—This new metal, and base of a new alkali, was discovered in 1860 by Professors Bunsen and Kirchhoff, of Germany, and through the accident of detecting in the spectrum of certain potassium compounds, on which they were experimenting, two bright blue lines or a double blue line not before observed, and situated near to that line of the strontium spectrum which has been marked  $\delta$ . (See SPECTRUM OBSERVATIONS.) The oxide of this metal appears very constantly to accompany in minerals and mineral waters those of potassium and rubidium. The associated alkalies, in solution, can be precipitated by bichloride of platinum; then separating the parts of the precipitate soluble in boiling water, and converting

the remaining chlorides into carbonates, the carbonate of the new metal is with certain precautions dissolved out with absolute alcohol. The salt thus obtained being placed along with mercury at the poles of a galvanic circuit, an amalgam of cesium is the result: the avidity of the new metal for oxygen is shown by the fact that, while the familiar alkaline metals, potassium and sodium, must when separated be preserved in liquids which, like naphtha, contain no oxygen, the separation in the metallic state of cesium has not as yet even been effected; and in the condition of amalgam it oxidizes in the air and decomposes cold water. In entire accordance with such facts, cesium is the most electro-positive element now known. Symbol, Cs; equivalent, 133.4. The hydrate of protoxide of cesium, chemically the analogue of hydrate of potash, is extremely caustic. Its carbonate, bicarbonate, sulphate, nitrate, alum, &c., have been investigated, and have in general a close resemblance to the corresponding compounds of potassium and sodium. The quantity of cesium in any source yet known is extremely small; but it is widely diffused in nature. The largest proportion yet found in any source is that given by Prof. O. D. Allen ("Amer. Jour. of Science," Dec. 1862), as the product from a lepidolite from Hebron, Me., of which it formed somewhat more than 0.3 of one per cent. It has been stated to be a constituent of the human blood and tissues. The chloride and perhaps other compounds of this and the next named metal may, it is believed, now be obtained in small quantities of dealers in the rarer chemicals in this country.

**Rubidium.**—This second new alkaline metal was discovered, in like manner with the former, through spectrum observations; its characteristic, two bands of dark red lying in the extreme and usually invisible portion of the spectrum at the red extremity, having been detected during prismatic analysis of the light colored by an impure compound of cesium which contained it. The associated alkaline metals existing in certain lepidolites being precipitated as above, the precipitate is reduced with hydrogen, and the chloride of the new metal being extracted with water, is purified by repeated precipitation and boiling. The chloride being converted into a carbonate, cesium is removed by repeated extraction with alcohol; and an amalgam of rubidium is then obtained in the manner above described. In this condition, rubidium also oxidizes in the air and decomposes cold water: it is electro-positive in reference to potassium, but stands in the scale below cesium. Symbol, Rb; equivalent, 85.36. Its hydrate is strongly caustic; several of its salts have been investigated. Its chloride, like common salt, crystallizes (though not readily) in cubes, which are permanent in the air. Prof. Allen prefers the process of extraction of cesium and rubidium in the form of bitartrates. The greatest quantity of rubidium yet found is that obtained in 1862 by Bunsen from a lepidolite from Rozena in Moravia, equal

to .03. Grandeau has recently found that rubidium exists in the ashes of the beet, in tobacco, coffee, tea, and raw tartar, so that there is little doubt of its presence in the human system. Since it had previously been shown to exist in many minerals, and mineral waters, rubidium must be regarded as an element very widely distributed in nature. An interesting result of these discoveries, and of the determination also of the characters of oxide of lithium, is that henceforth, instead of the familiar *two*, we must admit at least *five* positive fixed alkalis; namely, cesia, rubidia, potassa, soda, and lithia. The first three of these, also show a remarkable tendency to exist associated, whether in the solid or liquid state; and they manifest a similarity of behavior that renders their separation difficult.

**Thallium.**—This new metal, the existence of which was suspected in 1860 by Mr. Wm. Crookes, through detection by him of a before unobserved green band in the spectrum of light colored by certain residues probably containing also sulphur, selenium and tellurium, was afterward chemically separated by him, and by M. Lamy, of France—the complete accounts of the substance by both these explorers appearing in 1862. As obtained in quantity, thallium is a metal strongly resembling lead, though in some respects more similar to tin. Freshly obtained, it is nearly as white as silver, and on cutting shows a brilliant metallic lustre. It is extremely soft and malleable, easily cut and scratched with the nail; and like lead it readily marks paper, but with a yellowish streak. Its density is 11.9, a little higher than that of lead; symbol, probably Th; equivalent not given. It fuses at 290° O. = 554° F., and at a red heat volatilizes. It tends strongly to crystallize, so that bars of it obtained by melting crackle when bent like those of tin. Its most remarkable physical property is, perhaps, the green light which it imparts to flames; a quantity of the metal so small as the  $\frac{1}{100,000}$  part of a grain in a flame is indicated in the spectrum by its characteristic green band. The oxide of thallium appears to have alkaline properties in a degree. Several of the ordinary salts have been investigated. Thallium is not a rare body, being found in pyrites and associated with native sulphur, from various localities. It can be reduced from its salts by an electric current, or with charcoal at high temperatures, or by precipitation with zinc. For more full accounts of this metal and its compounds, see "American Journal of Science," Sept. and Nov., 1862.

**Lithium.**—The equivalent of this element appears to be not yet decided. Troost has recently found it 7.06; Diehl, 7.026; and Mallet has given it as 7. Regnault, in calculations of the specific and atomic heats of certain elements, has taken the equivalent of lithium as 6.43 (O being 8); but he repeats his suggestion, long since made, that the true equivalent is half this, the constitution and symbol of lithia being according to his view  $L_2O$ ; as



he would also make potash and soda  $K_2O$  and  $Na_2O$ .

**II. COMPOUNDS. Hydruret of Iron.**—Wanklyn and Carius have studied the action of zincethyl ( $C_2H_4Zn$ ) upon the chlorides and iodides of silver, copper, iron, and nickel. In case of the iodide of iron, and probably of the chloride of nickel, during the reactions hydrogen seems to combine directly and simply with the metal. With iron, the product is a black powder, which at ordinary temperatures and with exclusion of water is preserved unchanged. Distilled water being brought in contact with the compound, pure hydrogen is given off, and protoxide of iron remains. The composition of the hydruret of iron is inferred to be  $Fe_2H_2$ , though it is difficult to obtain it free from metallic iron.

**Peroxides of Potassium and Sodium.**—Harcourt has investigated the action of dry air and oxygen on metallic potassium and sodium. By carefully regulating the heat and the supply of dry air, potassium may be wholly converted into a white oxide, probably the binoxide. As the oxidation increases, the color inclines to yellow, and by employing finally pure oxygen, a chrome yellow powder is obtained—the peroxide—its composition being regarded as  $KO_2$ . Thrown into water, this powder sets free pure oxygen with effervescence, and the binoxide,  $KO_2$ , remains. The peroxide of sodium is prepared by a similar process, and when not heated is of a pure white color.

**Silicuretted Hydrogen.**—Silicium belongs to the same group of elements as carbon; but the analogue of  $C_2H_4$  (light carburetted hydrogen) has only recently been found. Wöhler, in certain decompositions with the galvanic current, observed bubbles of a spontaneously inflammable gas to arise at the aluminium electro-negative pole. The aluminium employed was found impure with silicium; and it was inferred that the gas was silicide of hydrogen,  $Si_2H_4$ . Very recently, Dr. Martins succeeds in preparing this gas in abundance. He mixes, in a wide-mouthed bottle, 80 parts of chloride of magnesium, 20 of the chlorides of potassium and sodium (taken in equivalent proportions), 40 of sodium, and 70 of silico-fluoride of potassium, all dry, the sodium in small pieces added last to the mixture of the others, and the whole then well agitated together; and then suddenly projects the mass into a tall Hessian crucible heated to redness, covering this tightly. The mass fused, the crucible is broken, and the slag removed. This contains the required material for yielding the gas—a silicide of magnesium; and being broken up, is acted on under water with strong hydrochloric acid. The gas can be collected over water or mercury; but allowed to escape in bubbles into the air, it explodes into a white flame, giving ascending rotating rings of smoke, in the manner of phosphuretted hydrogen ( $H_2P_2$ ). It gives, however, no offensive odor, and finally scatters in fine flakes of white dry hydrated oxide of silica ( $Si_2H_4O_4$ ).

**Hydrofluosilicic Acid.**—H. Deville prepares

this acid by causing water to fall, drop by drop, upon a mixture of fragments of stone ware and of fluor spar, heated to redness in a tubulated earthen retort; or less conveniently, by passing steam through such a mixture. Condensing the vapors that arise, the liquid acid of about  $17^\circ$  (Beaumé) is obtained; and this may be concentrated even to  $29^\circ$  (B.), its maximum density, without deposit of silica—a result with the acid prepared in the ordinary way, quite impracticable. At its maximum, the acid is very energetic, expelling, when heated with their compounds, almost all acids save the sulphuric. It has little action on stone-ware vessels; rapidly destroys glass; but since it does not attack organic matters, it can be kept in wooden kegs. It is probably to become of considerable industrial importance. (*Annales de Chim. et de Phys.*, lxi, 333).

**Hyperchloric Acid.**—Roscoe has investigated the hydrates and principal salts of this acid, which is obtained by decomposing chlorate of potash with fluosilicic acid, distilling the chloric acid, and purifying the distillate by means of the hyperchlorates of silver and barium. Pure concentrated solution of hyperchloric acid is a colorless heavy oily liquid, strongly resembling concentrated sulphuric acid. Distilled with 4 times its volume of concentrated sulphuric acid, above  $110^\circ C.$  dense white vapors pass over; at  $200^\circ C.$  oily drops succeed, condensing to a crystalline mass. The liquid is hyperchloric acid ( $ClO_2H$ ); the crystals, the hydrate discovered by Serullas ( $ClO_2H + 2HO$ ). The pure acid is a colorless liquid, density 1.782, at  $15^\circ C.$  Its vapor attracts water in the air, forming dense white fumes; dropped in water, the mixture is strongly heated; dropped on paper, wood, &c., it explodes; on charcoal, almost as violently as the chloride of nitrogen. On the skin it produces a painful ulcer, healing only after some months. Kept, even in the dark, it spontaneously decomposes, becoming darker, and finally explodes. In the same paper, the author describes the hyperchlorates of ammonium and some of the metals. (*Ann. der Chem. und Pharm.*, cxxi, 346.)

**Combustion of Hydrocarbons in air at Ordinary Temperatures.**—Karsten appears to have proved, by experiments related in *Poggendorff's Annalen*, vol. cix, p. 346, that organic substances containing carbon combine at ordinary temperatures with the oxygen of the air, forming carbonic acid and water; and he argues that, since pure carbon is thus oxidized at common temperatures, as at higher, only more slowly, the prevalent theory of the necessity of a prior decay in some nitrogenous body, to set up destructive change in the hydrocarbons, is a mistake; in other words, that the presence of the nitrogenous substance is not essential. Under water, if air have access to them, the organic hydrocarbons (as woody fibre, starch, &c.) are oxidized more rapidly than in the dry state; the access of air insufficient, they rot, yielding carbonic acid and other gases yet im-

perfectly understood; and when oxygen is completely excluded, they remain unchanged. It then remained a problem, important in connection with the vital processes of the animal organism, to determine what becomes of gaseous hydrocarbons escaping into the air during putrefactive decay, and of other particles set free in air, such as the odorous, &c.; the probability being that these would be acted on in like manner. This also Karsten believes he has now proved by experiment ("Philos. Mag.," 1862). Through a carefully cleaned apparatus of small tubes and bulbs, he passed about 30 gallons of moderately heated air, at the slow rate of about 9 pints in 12 hours. The air before entering was passed through caustic potash, with precautions to secure the removal from it of all contained carbonic acid. Just before its escape from the apparatus, it passed again through pure caustic potash or lime water. If now, before admission to the first solution of potash the air was heated to redness, so as at once to burn up all the organic matter in it, then in no case did the second potash solution or lime water give indications, by forming of carbonate of potash in the one case, or by turbidity in the other, of presence of carbonic acid; but if the admitted air were not thus burned, during the slow passage of the current the lime water soon became turbid, or the potash solution gained in weight, and yielded some carbonate of potash. The carbonic acid thus appearing must have been generated by slow combustion of gases or particles containing carbon, in the air while moving through the tubes. [Query: Did the condensing power of surfaces, as in case of platinum sponge or a clean platinum slip, have any influence in producing the result given?]

III. ALLOTROPIC STATES. *Oxygen*.—One of the most singular, and now somewhat familiar principles determined by modern chemistry, is that of allotropism, or the existence of the same element in several conditions, in which both its physical qualities and chemical behavior are almost or entirely different. One of the most familiar instances is afforded by the element carbon, in its two extremely unlike states of diamond and coke or charcoal. So, phosphorus exists as the ordinary yellow solid, and in transparent crystals, both highly poisonous and inflammable in air, and again, as red or amorphous phosphorus, in which state its inflammability and poisonous character are in comparison well nigh lost, and its properties in other respects are greatly changed. Among the most interesting instances of the sort, however, is that of allotropic oxygen or ozone, discovered some years since by Prof. O. F. Schönbein. More recently, this chemist has endeavored to show that beside the division of ordinary oxygen and ozone, a second must be made, the ozone itself obtained from different sources and under unlike conditions behaving differently toward other bodies, in such a way as to suggest that it has two opposite or polar conditions, which

he proposes for distinction's sake, to mark as — and + ozone, or to name *ozone* and *ant-ozone*. In a communication during the year 1862, he states that he succeeded in isolating ozone from an ozonide (an oxide containing the allotropic oxygen); and has found tests, not named, for completely distinguishing the two ozones. The following is his latest method of producing ozone by purely chemical means: Dissolve pure manganate of potash in pure sulphuric acid, and introduce into the green solution pure peroxide of barium; common oxygen and ozone will both be set free; the latter being detected by the nose, and by other tests. With such ozone, Schönbein has oxidized silver at  $-20^{\circ}\text{C}.$  =  $-4^{\circ}\text{F}.$ ; and by inhaling it, secured a capital catarrh.

Sir B. C. Brodie, in a paper before the Royal Society, Nov. 21, 1862, claims to have anticipated in 1850 Schönbein's view that oxygen may exist in opposite polar conditions; while he presents experiments tending as he thinks to show that the differences in behavior of different classes of peroxides do not warrant the distinction of the contained oxygen into + and —, the differences appearing not to be fundamental and characteristic. He further lays down a somewhat new principle, to the effect that, in no case are the properties of chemical substances that may enter into composition constant for each substance, as their atomic weights are known to be; but that the properties are variable, depending in degree on the physical conditions in which the particles may be placed, and the nature of the other substances with which they become associated.

Prof. T. S. Hunt's communication ("Amer. Jour. of Science," March, 1861) helps to show the intricacy and unsettled state of this subject. The formation of a nitrite in moist air ozonized by the electric spark (Cavendish's old experiment), or by phosphorus, being shown by Rivier and de Fellenberg, they concluded that Schönbein's ozone was really nitrous acid ( $\text{NO}_2$ ). Marignac and Andrews, however, subsequently established that ozone is modified oxygen; and Houzeau proved its identity with the so-called *nascent* oxygen, as evolved along with the common form when peroxide of barium is decomposed by sulphuric acid. Prof. Hunt had proved that nitrous acid is generated when a current of air is caused to pass through permanganate of potash undergoing solution in sulphuric acid. He had suggested in 1848 that gaseous nitrogen is the anhydride amide, or nitril of nitrous acid, its proper formula being  $\text{NN}$ , and which, in contact with water, could generate at once both nitrous acid and ammonia ( $\text{NO}_2$  and  $\text{NH}_3$ ); and as the ammonia, while forming, is readily attacked by nascent oxygen when present, giving both nitrate and nitrite of ammonia, it follows that, ozone being brought in contact with moist air, both the nitrogen atoms of the nitril may appear in the oxidized state (giving  $\text{NH}_4\text{O.NO}_2$ , or nitrite of ammonia). This view will be seen to connect

itself with the theory following, of *Nitrification*; while it would further appear also, that many of the reactions ascribed to ozone may be regarded as due to formation of nitrous acid during decomposition of atmospheric nitrogen (NN) in presence of water and nascent oxygen.

IV. NITRIFICATION. The subject of the formation of the nitre-beds, or vast collections of nitrates in the soil of certain hot countries, or in caves, always one of great practical interest, appears very recently to have received a new elucidation through researches in theoretical chemistry. The most important natural source of nitre is the nitriferous soil of certain districts in Hindostan, yielding chiefly nitrates of potash and lime. Similar but less productive beds are found in parts of Persia, Egypt, Hungary, Spain, and South America. The floor of many caves is found largely impregnated with nitrates; in this respect the Mammoth Cave of Kentucky was the most noted, until in 1812 it was industriously worked for nitre. In the desert of Atacama, S. A., immense beds of nitrate of soda exist; and another at Iquique (Peru), quite inexhaustible in extent, is now largely worked. (For an account of the last named, see "Jour. of Franklin Inst.," June, 1862.)

The "Smithsonian Report," 1861, contains an able "Report on Nitrification," by Dr. B. F. Craig, in which the subject is considered under the following heads: 1. Our knowledge of the laws which govern the formation of nitre. 2. The manner and extent of its production in nature. 3. The methods that have been practised for its artificial formation. 4. The methods of artificial formation that have been suggested, or those which the present state of our knowledge would suggest. 5. Experimental investigations it would be desirable to make, for the advancement of the theory and practice of the manufacture of nitre.

A theory dating as early as the 17th century referred the formation of the nitre-beds to collection and decomposition of organic matters, vegetable and animal; but as this scarcely sufficed for the magnitude of the product, various attempts have been made to show how nitric acid could be generated from constituents of the air. This doctrine was first distinctly advanced, as well as supported by experiments, by Longchamp, in a paper before the French Academy, 1828. Before the same body, Nov. 1855, M. Cloëz detailed experiments made by passing air, carefully freed from organic matters and ammonia, through porous substances of different kinds (pounded bricks or earthenware, &c.), impregnated with potash and lime; the result being that nitrates of these bases were formed. In this case, the action is like that of spongy platinum on hydrogen and oxygen gases, the mechanical condensation of the gases within fine pores or on certain surfaces resulting like compression in evolution of heat and chemical union; and such an action could be supposed to go on also in a porous soil laved by the atmosphere. Thus finally the *fact* that ni-

trates, or rather the nitric acid in them, is produced from the atmosphere is settled: the question of the *mode* remained. Dr. Craig favors the theory proposed by Dr. G. C. Schœffer, based upon a general tendency of certain compounds—in this case, as he supposes, preformed nitrous oxide (NO),—to assume the elements of water, giving rise to nitrate of ammonia, and by substitution of potash, &c., to the fixed nitrates. Dr. H. B. Jones ("Philos. Transactions," 1851) had described the cases of direct union of the atmospheric nitrogen and oxygen, in instances of combustion taking place in the air. What Schönbein has now done is, to determine the fact and the conditions of a new source of nitrous, and probably therefore of nitric acid, and thus to offer a substantially new theory of the precise mode of nitrification.

Let a piece of clean linen, drenched with distilled water, dry in the open air (the water, of course, gradually evaporating from it); then moisten it again with pure water, wring out this liquid, and acidulate it with pure dilute sulphuric acid; it will strike a blue with starch paste containing iodide of potassium—the most delicate test for the nitrites. Moisten a bit of filtering paper with a dilute solution of chemically pure potash, and suspend it for 24 hours in the air: examination will then show it to contain a perceptible quantity of nitrite; and by longer exposure this is increased. Or, better still, heat in a clean porcelain basin pure water to about 133° F., and over the evaporating surface suspend bands of filtering paper soaked in a weak solution of potash or soda, or their carbonates; in a very short time enough of the nitrite of either alkali will have accumulated to produce the reaction of such salt. In various other ways, involving evaporation of water in air, the same results are obtained; where no base is supplied, the nitrite of ammonia being the product found. The conclusion reached is that, universally, where water is evaporating in contact with atmospheric air, a nitrite of ammonia, or of such other alkaline base as may be present, is formed. Of course, all linen and other fabrics dried in the air must contain discoverable quantities of nitrite of ammonia due to this source; and as a fact the purest water suffered to evaporate spontaneously into the air, took up enough of this salt forming at its surface to produce the nitrite reaction. Thus, the fact before known that the purest water slightly charged with sulphuric acid or potash, kept evaporating at near 133° F., in the open air, and replenished, comes to show first a perceptible quantity of ammonia, and afterward of nitrous acid, is now explained. The formation of nitrite of ammonia about slowly burning phosphorus, detected some months before, Schönbein now refers to the effect of evaporation of water going on about the heated phosphorus. If, in these cases, the composition of nitrite of ammonia be regarded as (NH<sub>4</sub>.NO<sub>2</sub>), it will be seen to be formed by direct union of 4 atoms of evaporating water with 2 atoms of

nitrogen—the water at the moment of evaporation appearing to be in a condition favoring such union. Schönbein thinks that in all cases of generation of nitrites during combustion of various bodies, the combustion is only the incident, evaporation being the true cause. In a more recent note on this subject, Prof. Hunt questions whether the results arrived at by Schönbein can be ascribed to evaporation, except in so far as the coöperation of water, and a slightly elevated temperature, are necessary conditions of the reaction.

But since evaporation of water is continually going on in the atmosphere, it will follow that the generation of nitrite of ammonia must be an equally constant phenomenon. When this salt is brought in contact with fixed bases, as potash, soda, lime, these respectively enter into union with the acid, the ammonia being set free; and the gradual oxidation of these fixed nitrites, converting them into the corresponding nitrates, is a result then readily admitted. In rainy countries, like our own, the nitrates that would accumulate in the soil are washed away as formed, disappearing through springs and rivers in the ocean. But in hot countries, which have a dry season of several months' duration, and where in many cases there pre-exist vast plains of alkaline earth, the resulting nitrates accumulate. The old theory of production from decaying organic matters is disproved by such marked instances as those of the nitrebeds of Bengal, and it may be added, of Atacama, where no sufficient supply of organic substances exists or can collect.

The new facts have, if possible, a yet more important bearing on vegetable physiology. Liebig long since made the bold assertion that no plant needs any artificial supply of ammonia or of matters capable of yielding it, enough of this nutriment being furnished, as he thought, by natural means. Whether this assertion was or was not too sweeping, Schönbein's discovery goes far in support of it. Plants cannot assimilate free nitrogen. But it is a well-known fact that all plants, during seasons of growth, are exhaling or evaporating water in abundance from their leaves; while it is through pores in the leaves at the same time that they mainly inhale or receive the carbonic acid and other compound gases, among them ammonia and nitrous acid, from which their supplies of organic matter are continually generated.

Accordingly, if the new facts and theory be, as now appears, established, a very important step is gained in showing that every growing plant supplies by evaporation the conditions for the generation of certain inorganic gaseous compounds indispensable to its own nutrition, and that at the very points where such materials are required for appropriation, namely, at the porous surfaces of the leaves.

V. SYNTHESIS OF ORGANIC SUBSTANCES. The opinion that substances naturally of organic origin, or directly derivable from such, as for example, sugar, albumen, urea, common al-

cohol, &c., could only result through prior agency of living bodies, and in no case by direct union of their elements (artificial synthesis), took firm hold of the minds of most chemists during the earlier development of the organic department of the science. The first fact in contradiction of this belief, was the production by Wöhler of urea from its elements, that is, from inorganic compounds obtained in the ordinary ways from such elements, in 1828. Thus, he found that physically as well as chemically urea is identical with cyanate of ammonia ( $C_2H_4N_2O_2 = NH_4O + C_2NO$ ). Since the date just given, the number of syntheses of organic substances has become quite considerable; and some of them are highly important. Through the researches of Perkin and Duppa, and of M. Kekulé, the chemist is now enabled to build up step by step from their elements three highly complex organic acids, the succinic, parataric, and malic. Mr. M. Simpson ("Philos. Mag." vol. xxiii, p. 827, 1862) gives an improvement of his previous process for producing succinic acid, by employment of bromide of ethylene ( $C_2H_4Br_2$ ), and which yields the acid directly and in a state of purity. In the same journal and volume, is an account of the first synthesis of a substance possessing saccharine qualities, by Boutlerow, by action of lime water on a solution of di-oxyethylene.

*Alcohol, &c.*—In the French department of the London Exhibition, of 1862, could be seen a bottle of alcohol, differing in no respect of taste, odor, or other qualities, or of composition, from ordinary alcohol, save in the mode of its origin—being a product of chemical synthesis, accomplished by M. Berthelot. He first ascertained that olefiant gas ( $C_2H_2$ ), agitated with many thousand concussions with sulphuric acid ( $SO_3, HO$ ), combining with two equivalents of the latter, produced sulphethylic acid ( $C_2H_2O, SO_2 + HO, SO_3$ ). When this acid is heated with water, common or vinic alcohol results, distilling over, and leaving sulphuric acid behind. But if any other substance homologous with ( $C_2H_2$ ) be substituted, the corresponding alcohol, as the amylic, &c., is produced. It is claimed that while Berthelot's first mention of this method to the French Academy dates Jan. 1855, the Sieur Castex had in the preceding December taken out a patent for producing alcohol by absorbing smoke from burning organic matter in concentrated sulphuric acid, mingling with water and distilling.

Berthelot's more recent method, however, breaks down yet more strikingly the distinction between inorganic and organic chemistry. Acetylene ( $C_2H_2$ ) is known as one of the simplest and most permanent of the hydrocarbons. It was formerly obtained from olefiant gas, by action of the electric spark, or otherwise. Berthelot has now succeeded, first, in producing acetylene by synthesis. Carbon is first highly purified, as by action of chlorine

aided by heat; but this being submitted to action of hydrogen at the highest possible temperature, or by the induced electric spark, no union occurs. If, however, the electric arc is caused to pass between electrodes composed of this carbon, and in an atmosphere of hydrogen, the conditions of union are secured; acetylene begins at once to be produced, and continues to be so as long as the conditions are maintained: the product being carried over and absorbed in an ammoniuretted solution of protochloride of copper, is liberated afterward by action of hydrochloric acid. With this acetylene Berthelot next succeeds in combining hydrogen so as to give olefiant gas ( $C_2H_4$ ); from this he proceeds to common or other alcohols, as above; from the alcohols, ethers are obtained by the well-known methods; and so on. Thus is started, directly from the elements, and capable of being extended indefinitely, a chain of compounds hitherto regarded as belonging exclusively to the class of products of organic or vital action.

Among other syntheses recently accomplished, are those consisting in the addition of the element hydrogen to certain compounds—the hydrogen being set free during oxidation of sodium-amalgam introduced into water. In this manner, Wurtz has transformed aldehyde into alcohol, by mixing the former in water and introducing the amalgam named. Friedel, by means of the nascent hydrogen set free by the sodium-amalgam, has converted other aldehydes, as the benzoic and valerianic, into their corresponding alcohols. Kekulé, through union of  $H_2$ , has transformed fumaric into succinic acid; and Linnemann has effected the transformation of sugar into mannite.

The practicability of producing artificially the albuminous or protein substances, having been suggested some years since by Prof. T. S. Hunt, in accordance with his theory regarding those substances as amids or nitryls, and being also rendered probable through the researches of Laurent, Gerhardt, and others, certain chemists have given much attention to experiments having this end in view. Up to the present time, however, nothing very decisive has been effected in this direction. As, however, by action of ammonia on chloroacetic acid, glycol ( $C_2H_4NO_2$ ) is obtained, Volhard, by substituting in this reaction methylamine ( $C_2H_5N$ ) for ammonia, has effected the formation of *sarcosine*, a compound which Liebig had obtained as a product of the decomposition of  *kreatine* —the latter being found in the juice of flesh and in the urine.

VI. DIALYSIS. Professor Thomas Graham has been conducting through several years a series of researches in one line of connection between chemistry and physical science. The most important of the results attained by him have been given to the world in his papers on "Diffusion," "Osmose," and finally that on "Liquid Diffusion applied to Analysis." Of these it has been remarked that, while probably

the author could not himself have foreseen the value of the conclusions he was to reach, there is nevertheless a logical sequence in the subjects and the developments they have afforded; and that, since Davy startled the scientific world with the announcement of the metallic bases of the alkalies, the science of chemistry has scarcely received any other contributions so pregnant with important results. The principles arrived at in the investigation last named, in fact, serve to show more distinctly than ever before the close connection of chemical phenomena, not only with the physical, on one side, but also with the physiological, on the other. As a mark of appreciation of the entire series, the Royal Society in 1862 awarded to Prof. Graham the Copley medal.

The mode of analysis by diffusion Graham denotes more briefly by the term Dialysis. Essentially, the method is one which serves to separate one from another certain substances, usually compounds, by taking advantage of the different rates at which such substances are capable of diffusing through moist gelatine-like films or other partitions, or upward through water or viscid masses. A simple method of effecting this consists in placing the mixture of bodies to be separated in a cylindrical glass vessel 5 or 6 inches deep, and so carefully introducing water above as not to disturb or intermix them. After a few days, the upper strata of water can be successively drawn off by means of a pipette into as many different vessels; and analysis of these shows what substances have become most diffused, and in what quantities. For practical purposes, the "hoop dialyser" is usually to be preferred; this consists of a vessel in shape of a sieve, 8 to 12 inches across and 3 inches deep, the rim of gutta percha, the bottom of parchment paper. Placing in this a mixed solution of gum and sugar, with pure water enough to cover the bottom to the depth of half an inch, let the vessel float upon a larger quantity of pure water: in 24 hours, all the sugar will have passed through the membrane, and so free from gum that the solution is scarcely rendered turbid by basic acetate of lead, while on evaporation it yields crystallized sugar. Like the sugar, all bodies capable of distinct crystallization in some degree, diffuse with comparative readiness, though at quite different rates, through liquids, gelatinous masses, and most porous septa: of these bodies, good examples are the chlorides, sulphates, and other salts of metallic bases. On the other hand, bodies having little or no tendency to crystallize, and which incline in presence of water to assume the form or appearance of a jelly, of which starch, vegetable gums, caramel, tannin, albumen, a number of hydrated metallic peroxides (as silica), etc., are examples, possess comparatively little or no power of diffusion under like circumstances. Professor Graham accordingly divides bodies generally, in view of their behavior in this respect, into the two classes of—1, the crystal-

line and diffusible, which he names crystalloids; 2, the amorphous and non-diffusing, which he names colloids ( $\kappa\omicron\lambda\lambda\alpha$ , glue). Any substance separated by diffusion is named a diffusate. For an application of the process in case of silica, see BUILDING MATERIALS. The most diffusive of known substances are hydrochloric acid and the allied hydracids; and next in the scale are the solid chlorides, but particularly those of potassium and sodium. The times required for an equal diffusion of the following substances, were—hydrochloric acid, 1; chloride of sodium, 2.83; sugar, and sulphate of magnesia, 7; albumen, 49; caramel, 98. The rates of diffusion are accelerated by heat; and they are less in alcohol and other liquids than in water.

Generally, the new process serves for separating a crystalloid from associated colloids, or the reverse, and to some extent for separating the more from the less diffusible bodies. Among particular applications, are those of purifying certain colloids—albumen dissolved in water with acetic acid being in this way after 3 or 4 days entirely freed from the alkaline and earthy salts, and with retention of the sulphur which enters into its constitution. In like manner, arsenious acid and certain other poisons are separable from organic substances, and in great purity, so that the method must prove valuable in cases of suspected poisoning.

Liebig has claimed that Graham's explanation of diffusion—to the effect, namely, that crystalloids are bodies which by their affinity for water can abstract it, molecule by molecule, from gelatinous masses or moist septa, and can so advance gradually through the latter, while colloid bodies by their want of affinity for water have no such power—is identical with that proposed by himself in relation to motion of liquids in the animal body, in 1848. He calls attention also to the importance of dialysis in the study of the chemical constitution of the animal and vegetable secretions.

The colloids are the inert bodies, but having great sensibility to external conditions, and being thus highly mutable or unstable. The crystalloids are chemically active or energetic, but unsusceptible to external agencies. But the mutability of the former fits them for the part which some of them have to play in the metamorphoses of living tissues, in connection with nutrition, decomposition, and the manifestation of vital force; while the more unalterable crystalloids have no such capacity. Thus, these elements stand physiologically in relations the reverse of those they show chemically; and Graham accordingly terms the crystalloid a *statical*, and the colloid a *dynamical* condition of matter.

At least two economical applications of dialysis have been very recently proposed. Dr. Marcet has dialyzed in small quantity the brine or refuse liquor from the curing of meat, and having by the process separated the salt, the liquor containing the juices from the meat be-

comes fit for use as an article of diet. He suggests that if this separation can be effected without too great cost on the large scale, the liquor could be converted into soup for prisons and penitentiaries, or, in the present crisis, for the half starved cotton-spinners of Lancashire. It has also been suggested that the much debated question of utilization of town sewage may perhaps be solved by the process of dialysis. The solid matters of the sewage are diffused through so enormous a quantity of water as to render the whole comparatively valueless. But these solid matters consist of crystalloids (salts of various character) and colloids (organic substances); and the former are the materials, the return of which to the soil is especially to be desired. The question now raised is, whether dialysis can be economically applied to the separation in compact form and saving of these mineral elements of fertility of soils.

VII. TRANSPIRATION (Liquid), in its relations to chemical composition. The phenomena of passage of liquids under pressure through capillary tubes, first developed by M. Poiseuille, Prof. Graham has recently studied, under the name of Liquid Transpiration. To this study he was led by remarking that alcohol diluted to different degrees, is most retarded in its passage through a capillary tube at that degree at which the greatest condensation of the mixed liquids takes place. This he understood to indicate that the definite hydrate of alcohol containing 6 equivalents of water was the one most retarded; and if so, the rate of transpiration appears to depend on chemical composition, and to indicate it. This new physical property might thus become available, like the boiling point and others, as an aid in fixing chemical composition. The trials made on other alcohols and hydrated acids appear to establish a relation between transpirability and composition. Of nitric acid ( $\text{NO}_3$ , HO) with water added in successive proportions up to 100 parts, the maximum time of transpiration, at  $20^\circ\text{C}$ ., was at the dilution corresponding to 8 equivalents of water; the time being then 2.1084 (taking that of water as 1), and diminishing both ways. In case of acetic acid, the greatest time was at the dilution answering to 2 equivalents of water; in that of sulphuric acid, it was also at 2 equivalents. Relation of transpiration time to boiling point is shown in the alcohols, thus:

SUBSTANCES.	Transpiration time.	Boiling point.
Methylic alcohol .....	0.690	$151^\circ\text{F}$ .
Vinic (common) alcohol .....	1.195	$178^\circ\text{F}$ "
Amylic alcohol .....	3.649	$270^\circ\text{F}$ "

Thus, generally, slow transpiration and low volatility appear to go together, and to be connected with a heavy molecule; in this way, it would appear, the water added to hydrated alcohols and acids acts to impede their transpiration. A fixed temperature being desirable

in comparisons of the sort here considered, the author suggests  $100^{\circ}\text{C.} = 212^{\circ}\text{F.}$

The researches on several of the homologous series of organic bodies are still going forward, the number and relations of the substances formable in such series being as yet subject to indefinite extension. For these researches and the new compounds developed in them, as well as some others, the reader must be referred to the chemical journals.

VIII. APPLICATIONS OF CHEMISTRY. It has been, of course, impossible to present the preceding more theoretical topics without reference under some of them to applications in the arts or otherwise; but the subjects following are such as possess more purely a practical bearing or value.

*Webster's Oxygen Process.*—In this is employed a furnace containing a strong cast-iron vessel 10 inches in diameter, in which is placed a smaller one 7 inches in diameter, open at the top, and provided with an orifice at the base, temporarily stopped with sheet-iron: when its contents are exhausted, they can be beaten out through this with an iron bar. The outer vessel is connected by a pipe with a 30-gallon stone-ware vessel, containing  $\frac{1}{2}$  gallon of water, and 8 stone-ware colanders, upon which is placed 48 lbs. of the residue of a previous experiment, to serve as a purifier. The inner pot is charged with 10 lbs. of warm dry nitrate of soda, and 20 lbs. of warm dry crude oxide of zinc, the latter obtained from the so-called galvanic baths. A cover is luted on, and heat applied sufficient to give to the mass a pasty character. Oxygen is speedily given off, with nitrous fumes; these the purifier absorbs. By the process, a large quantity of oxygen is obtained at small cost, but mixed with nitrogen to the extent of .41. For many uses, as in the various metallurgic processes, this intermixture is in no way detrimental; and it is even supposed capable of augmenting the illuminating power of coal gas which the oxygen may be employed to consume.

*Potash from the Animal Kingdom.*—Hitherto the supply of potash has been obtained mainly from vegetable sources. Recently M. Maumené, a French chemist, has obtained this alkali in considerable quantity from an animal product, the yolk, or oily soap, naturally secreted along with the growth of wool, and usually constituting from  $\frac{1}{3}$  to  $\frac{1}{2}$ , or even more, of the entire weight of the unwashed fleece. The fleeces of sheep's wool sheared without washing or pulled, are submitted to action of cold water in a tank or reservoir, and the yolk, which is a combination of fatty and oily acids with potash, readily dissolves out of them. Separating the soap, and heating it to redness, a very pure carbonate of potash is obtained. The process is so productive, that it is already worked as a commercial speculation at Rheims, and samples of the potash salts were shown at the International Exhibition.

*Copper Paint.*—The Abbé Moigno describes,

in the "Cosmos," a new pigment which has come into use in the workshops of M. Oudry, of Autenil. Copper set free from some of its salts by the electrolytic process, is reduced to an impalpable powder, and mixed with benzine: this may be employed on any surface as a paint. It possesses an agreeable lustre, and takes bronze tints by the usual means. By reducing the quantity of copper, and adding bases of lead, zinc, or other suitable metal, M. Oudry has produced a series of paints said to possess great advantages over the ordinary preparations with turpentine and oils.

*Aluminium Bronze for Philosophical Instruments.*—Lieut.-Col. A. Strange, having to superintend the construction of some astronomical and geodesical instruments of large size, for the Trigonometrical Survey of India, and the instruments requiring to be transported over ground very unfavorable for such carriage, was about to have certain parts usually entire cast in separate portions, when his attention was called to some articles in the International Exhibition, made from aluminium bronze, and which were from the works of Bell Bros., of Newcastle, and M. Morin, of Paris. He proceeded to have careful series of experiments conducted by different parties with a view to testing the qualities of this bronze; his summing up of the results attained being communicated to the Astronomical Society, and appearing in its "Notices," Nov. 1862.

The alloy named was first made by Dr. Percy, about 6 years since. It is composed of the metals aluminium and copper in various proportions; the alloy of 10 parts aluminium to 90 of copper giving the best material for most mechanical purposes. The twelve qualities regarded by Mr. Strange as most essential in a metal for the making of astronomical and other philosophical instruments, will be named in order, and the results in the several particulars obtained in respect to the aluminium bronze will be briefly noted under each. 1. Absolute or tensile strength. The aluminium bronze in good bars broke with a weight of 78,185 lbs. to the sq. in. section; gun metal, at 35,040 lbs.; while an average quality of steel breaks at about 80,000 lbs., some qualities however ranging much higher. 2. Resistance to compression. The bronze showed no perceptible compression until the load upon it reached 20,384 lbs. per square inch; then it suddenly yielded .006 of an inch, regaining .001 when the load was removed. Its ultimate compression, or the load at which it yielded so as wholly to lose its form, preparatory to crushing, was 132,416 lbs.; while the ultimate compression of cast iron is about 115,542 lbs. The bronze is thus exceedingly hard and incompressible. 3. Malleability. This is excellent: the alloy is malleable almost up to melting, and it can be drawn under the hammer almost to a needle point. 4. Transverse strength, or rigidity. On this quality the perfection of astronomical instruments is more dependent than on any other singly.

For the alloy, this was ascertained comparatively; the same weight being applied to bars of the three metals and of like dimensions, while the index of the instrument measuring the deflection showed for the bar of brass 2.22 divisions of the scale, for that of gun metal it was .15, and for that of the bronze .05. Thus, the rigidity of the bronze is three times that of gun metal, and about 44 times that of brass. 5. Ratio of expansion by heat. This also was found comparatively; and the bronze proved to be slightly less expansible under increase of temperature than gun metal, much less so than brass. 6. Founding qualities. The bronze produces admirable castings, of any required dimensions. 7. Behavior under abrading and cutting tools. The bronze does not clog the file; and in the lathe or planing machine, it cuts with clean, free, elastic shavings. It appears to be worked in these ways with less difficulty than steel. 8. Resistance to atmospheric influences. The new alloy tarnishes less readily in air than any of the metals usually employed for the instruments under consideration; viz., than gun metal, brass, silver, cast iron, or steel. 9. Fitness to receive graduation. The bronze readily takes a very fine division, and thus saves the need of inlaying another metal to receive any required scale. 10. Elasticity. The experiments on this point were comparative only; but the metal was found highly elastic. 11. Fitness for being made into tubes. The alloy admits of all the operations requisite for the making of tubes. It can be rolled into plates or hammered and drawn, and is soldered either with silver or brass solder. 12. Specific gravity. Of the bronze here described, containing 10 per cent. of aluminium, the sp. gr. is 7.689; being nearly that of wrought iron, and less than that of either brass or gun metal.

Generally, then, the new alloy (made with .10 Al.) is in all respects superior to any metal heretofore used for constructing philosophical apparatus. It should be employed in the relative dimensions suitable for cast steel. Besides its use for larger work, its hardness and great inoxidability fit it for the making of pivots, axes, and bearings. Along with its other good qualities, use of the alloy keeps the weight of the instruments within reasonable limits. Aluminium is at present extracted in England, under a license from the originator of the process, M. Deville, by one firm only—that of Bell Bros., of Newcastle. A pure copper is requisite; the best, however, that deposited by electrolytic action, is too expensive; the next best is the copper from the Lake Superior mines. The alloy must be remelted 2 or 3 times; and its tenacity and strength are in fact improved by repeated remeltings (though the percentage of aluminium may finally be reduced), so long as the forging qualities of the alloy show improvement. The present price of the aluminium bronze is very high, being equal to about \$1.50 Federal money, per lb.;

but it will doubtless fall with increasing production and familiarity with its use.

*Aluminium Wire.*—Metallurgists had already succeeded in forging aluminium, in filing, rolling, punching, and in engraving it with any sort of design. But the drawing of this metal into fine wire has only recently been effected by M. Garapon, of Paris. Commencing with rods of about 40 inches length and  $\frac{1}{4}$  inch diameter, he succeeds in extending these until they are, if desired, reduced to the diameter of a hair. This wire, which, unless acted on by sulphur fumes or a very few other gases seldom present, retains the perfect brightness of the metal, and which has also its extreme lightness, is now employed in the making of such articles as lacework, epaulets, embroideries, head dresses, &c. It is furnished at 60 or more per cent. cheaper than silver wire of like measurement.

*Artificial Plumbago.*—Dr. Grace Calvert has experimented on gray (cold-blast) cast iron, by placing small cubes of this metal, about  $\frac{3}{4}$  inch diameter, in weak solutions of several acids, sulphuric, phosphoric, acetic, &c., of about 80 times the volume of the metal, within corked bottles, renewing each acid about once a month for two years. At the end of this time the action of the acetic acid was evidently still going on upon the block contained in it; but this cube, which originally weighed 15.324 grammes, now weighed only 3.489 grammes, its specific gravity being reduced from 7.858 to 2.751. From Dr. Calvert's analyses of cubes of iron thus treated, and then reduced to fine powder in a mortar, it is shown that the iron had become transformed into graphite or plumbago; that most of the nitrogen originally in the iron remains in the graphitoid substance, a portion of it having gone to form ammonia in the solution; that the carbon of the cast iron was in like manner diminished in the graphite, a portion going to form carburetted hydrogen; and that it is silicium, not silica, which enters into the graphite compound. Thus, finally, he regards plumbago as a compound of about 91 per cent. of a subcarbide of iron, with about 8 $\frac{1}{2}$  per cent. of a nitride of silicium, and traces of phosphorus and sulphur. ("London Mining Journal," No. 1377.)

*Determination of Carbon in Iron.*—Wich determines in a simple manner the quantity of carbon in cast iron or steel, without the necessity of pulverizing the metal. He makes the iron to be analyzed the positive electrode in dilute hydrochloric acid: the metal dissolves, leaving the carbon, and without evolution of gas. It is necessary to regulate the strength of the current by so adjusting the distance of the electrodes that only the protochloride of iron shall form (production of the sesquichloride being indicated by a yellow color of the solution): in the former case the iron does not become passive, and the action goes on properly. A single Bunsen's element suffices—the iron to be acted on being so held in a forceps of plati-



num points, that the platinum shall not be moistened by the liquid. The separated carbon is collected on an asbestos filter, dried in a current of air, and burned with oxide of copper and oxygen, in the usual manner. In this way its weight is to be determined; while the quantity of the iron dissolved is nearly enough found by weighing the portion remaining after complete solution of that which dips in the acid, and subtracting from the entire previous weight the sum of weights of this residue and of the carbon. A piece of cast iron weighing about 124 grains dissolves in this way in 24 hours.

*Nitrogen in Iron.*—Recent experiments have determined not only that nitrogen is a constituent of cast and wrought iron and of steel, but further, that in these bodies it is present in two conditions. That existing in one of the two states is liberated in form of ammonia when the iron is dissolved in hydrochloric acid, the nitrogen uniting with nascent hydrogen. The nitrogen present in the second state is left in the carbonaceous mass which remains after the iron is so dissolved, or which is obtained by heating with sulphide of mercury. These two states have been determined by the researches of Ullgren, who concludes that the quantities of nitrogen in both of them must be ascertained by liberating the element in the gaseous form. A consequence of the fact that one portion of the nitrogen may remain masked as it were in the residue of solution, while another readily manifests itself, must be that the amount of the element in the sorts of iron has been in some cases underestimated. The entire paper is found in Liebig's "Annalen," Oct. '62, and a note embracing the processes to be employed, in the "Philos. Mag.," Dec. '62, Supplement.

*New Fusible Alloy.*—Dr. B. Wood describes ("Amer. Jour. of Science," March, 1862) a new alloy produced by him, of cadmium 1 part, lead 6, bismuth 7, which melts at 180° F., or about midway between the melting points of the old fusible metal (of tin, lead, and bismuth), and of another fusible alloy described by him in the same journal, 1860, (of cadmium, tin, lead, and bismuth). The new alloy has a brilliant lustre and does not readily tarnish; color, bluish gray; it is very flexible, and has about the hardness of bismuth or of the common "coarse solder."

*Cupreous Acetylene.*—M. Crova finds that this substance, which is explosive, is produced in copper pipes that have been long in use for conveying coal gas. It is known that such pipes, on being cleaned out, frequently give rise to dangerous explosions; and also that cupreous acetylene detonates at high temperatures, or on being struck. Crova placed a quantity of reduced metallic copper in a flask containing equal volumes of air and acetylene, and with the addition in one instance of a little ammonia. The copper became black, and the flask being after some time opened under water, it was found that  $\frac{1}{2}$  the gases present had been

absorbed—slightly more when ammonia was present. The copper being washed and dried, and treated with hydrochloric acid, a considerable quantity of acetylene was disengaged. A portion of the compound unacted on being thrown on a heated metallic plate, explosion resulted, and more violent than with the ordinary cupreous acetylene. As coal gases always contain acetylene, and traces of air and ammonia, the formation of this dangerous compound in copper or bronze tubes conveying such gases, must almost of necessity follow. (*Comptes Rendus*, September 8, 1862.)—In January, 1863, a lady in Rochester, N. Y., was knocked down by an explosion following instantly upon the ignition of the gas in a room, and which she was lighting in the usual manner with a match. A boy near her was also prostrated, and the lathing and plastering of two or three rooms were torn off. The lady has since suffered from a partial paralysis. The explosive material was probably that just considered, or some other incidentally forming in the pipes or fixtures delivering the gas.

*Improved Matches.*—Messrs. Letchford and Company, London, improve the ordinary matches by substituting for the sulphur coating one of melted paraffine, which impregnates the wood and renders it more inflammable; the ordinary phosphorus coating, for ready ignition, is applied over this in the usual manner. These matches remain uninjured by damp, being the only sort found capable of igniting after six hours' exposure to a moist atmosphere; so that they are particularly suitable for export. Other advantages are their being free from the sulphurous acid fumes, on ignition, which are disagreeable and sometimes hurtful to the lungs; and that, for the like reason, they do not when lighted tarnish silver and other bright metallic surfaces near to them.

*India Rubber Varnish.*—Dr. Bolley obtains this varnish free from the usual imperfections; that is, in a perfectly dissolved, fluid, and colorless condition, by digesting India rubber cut into small pieces for many days in benzine, frequently shaking the containing bottle, then filtering, allowing the liquid to rest, and again straining through a woollen cloth. The residue separated by this last process affords a good water-proof composition. The varnish itself incorporates easily with fixed or volatile oils, dries fast, and if unmixed with any resin, does not shine. It is extremely flexible, can be spread very thin, and is unaltered by air or light. Its great advantages as a varnish for maps, prints, &c., are that it does not affect the whiteness of the paper, nor crack and come off in scales, nor produce a glare of reflected light in the manner of resinous varnishes, and so does not prevent the figure or print from being seen equally well in all directions. Unsized paper varnished with it can be written on with ink.

*Basis of Artificial Teeth.*—A composition to form the basis of artificial teeth has been proposed by M. and A. Gabriel, London. It con-

sists of India rubber 7 parts, sulphur 2, phosphate of lime  $2\frac{1}{2}$ , and phosphate of soda 2 parts. The object of the invention is to form a compound which will represent the natural bone, and also resist the action of the acids of the mouth and stomach. This compound is in the plastic state moulded, and then hardened, in the usual way, and afterward polished. It is then placed in an electro-galvanic bath, and a thick coating of pure gold is deposited upon it.

*Guano Polishing Powder.*—A patent has been solicited by Mr. W. Clark, of London, for a new polishing material for steel and other metals, as well as glass, composed of the extract of guano 100 parts, fine tripoli 25 parts, common sea salt 10 parts, and wheat flour 12 parts. These substances being mixed and dried, the powder formed is ready for use, save that at the time of applying it is to be wet up with dilute alcohol.

*Cement for Rooms.*—M. Sorel has discovered that a compound which he terms oxy-chloride of zinc possesses advantages, as a coating for the walls of rooms, over paint or plaster of Paris. A coat of oxide of zinc mixed with size, and made up like a wash, is first laid on the wall, ceiling, or wainscot; and over that a coating of chloride of zinc, prepared in the same manner as the first wash, is applied. The oxide and chloride effect immediately a sort of combination, forming a cement, smooth and polished as glass, and possessing the advantages of oil paint, without its disagreeable odor.

*New System of Bottling Liquids.*—For bottling beer, wine, cider, and other fermentable and perishable liquids, one general method has been in use from time immemorial; the bottling of milk, and the canning of eggs so as to secure their preservation, are still desiderata. Even in the processes of bottling, or of canning fruits, meats, etc., and hermetically sealing, a little air must usually be left within, so that this by its variations of volume under different pressures on it, may allow of the changes in the way of contraction or expansion of the soft or liquid contents, without risk of breakage of the vessels either from without or within. But this small quantity of air can suffice to set up fermentation or decay. Mr. Henry Dircks has proposed as a remedy against this evil a preparatory filling of the bottles with nitrogen, carbonic acid, or other innocuous gas, having in itself no power to induce change in the materials to be preserved, and which first serving like a filling with airless water to expel the detrimental oxygen of the atmosphere, may still remain in the small and needful quantity within the bottles or cans, to protect them during changes of volume of their contents. The gases named are quite harmless to the articles and to the health; while the addition in case of delicate old wines might be of great service. The filling of the vessels with such gases is easily effected on a large scale; methods for the purpose will readily occur to those conversant with like subjects—one such is

described in the "Athenæum," Jan. 1868. The writer supposes that by a method such as there indicated even fresh eggs, broken into cans containing nitrogen gas, and sealed in such an atmosphere, may be kept without change. Any shrinkage with the materials of any sort to be preserved, either from escape of juices, or cooling, could be replaced by the proper gas before sealing.

*New Process of Making Vinegar.*—Pasteur has been investigating the property of mycoderma, especially of those of wine and vinegar—the latter the *mycoderma aceti*, or microscopic plant of mother of vinegar (*fleur du vinaigre*)—in virtue of which they act as conveyers of oxygen from the air into various mixtures of organic substances, and lead to oxidation of the latter, often with a surprising rapidity. He turns the new property to account in a method for the manufacture of vinegar. The method of vinegar making commonly adopted in Europe with wines, and known as the Orleans process, has the disadvantage of producing multitudes of vinegar eels (*anguillula aceti*); while the German method, of trickling the liquid to be aceticified over beech shavings is not applicable to wine nor to beer in its natural state, and produces an inferior article, lacking the aroma of the original liquid. Pasteur sows the dried and crumbled mass of mycodermas on the surface of a liquid consisting of ordinary water having in it .02 of its volume of alcohol, and .01 of acetic acid from a previous operation: to this he adds about  $\frac{1}{1000}$  part of alkaline and earthy phosphates. The plant rapidly develops, filling the whole liquid, and meanwhile the alcohol is acidified. When about half the original alcohol is transformed, more alcohol, or wine, or strong beer is added day by day, in small quantities, until the liquid has about the commercial strength. When the action of the plant begins to be exhausted, it is left to complete the aceticification of the alcohol already introduced: it is finally separated from the liquid, and washed, yielding an acid and azotized liquid capable of further use; and the process is then repeated with a fresh body of alcoholized liquid. If at any time the plant wants a due supply of alcohol, it will transform the vinegar to water and carbonic acid; and the like result will follow if its growth is too rapid. Vessels about 40 inches square, and holding 10 to 20 gallons, yield at the rate of a gallon or more of vinegar a day. These may preferably be shallow wooden vessels, like the coolers used in brewing; and gutta percha tubes made to run along the bottoms of these, and perforated with small holes along their course, may admit the alcohol without disturbing the fungous film over the surface. The phosphates are required as mineral food for the mycodermas; the most suitable are those of potash, magnesia, and ammonia. The new process is not only suited to all the liquids named, but besides, the presence in it of the film of plants over the surface of the liquid, by consuming (as it is introduced) the

oxygen, prevents the development of the vinegar eels; and the natural aroma of the original liquid is also more fully retained. (*Comptes Rendus*, July 7, 1862.)

*New Hydrometer.*—The "Scientific American," May 24, 1862, contains a description of a hydrometer, the invention of Mr. Peter Hogg, of Brooklyn, N. Y., and which is designed to indicate densities of liquids equally well at any ordinary temperatures. The comparisons of the densities of different liquids, made with the usual forms of hydrometer, can only be strictly correct when the liquids themselves have the same temperature; and when, as is frequently the case in the process of refining sugar, and in other manufacturing processes, a portion of the liquid or solution must be cooled to the exact point taken for the standard of density, the operation is one of difficulty and requiring time, the result being that absolutely accurate tests are in this way rarely obtained. The new hydrometer, intended to obviate these difficulties, consists essentially of a tube closed at its lower end by a flexible diaphragm, and which, while placed in a vessel of water, is filled with the same liquid up to a certain point. When this tube so filled is afterward plunged, up to the same point, in any liquid to be tested, the contained water being soon brought to the same temperature as the surrounding liquid, it will follow that, according as the specific gravity of such liquid in contact with the outside of the flexible diaphragm is greater or less than that of the water resting on the inside of the same diaphragm, the column of water in the tube will be thereby caused to rise or fall; and the tube being properly graduated, the specific gravity of the liquid will be indicated by the height at which the column of water comes to stand within it. As a further part of the invention, the hydrometer described is so placed within an inverted syphon, through which the liquid to be tested may flow constantly, that the specific gravity of the liquid can be at any time ascertained, by simply observing at what point of its scale the hydrometer tube stands immersed in it.

*Myrtle Wax.*—The fruit of the bayberry (*Myrica cerifera*) yields a wax which, under the names of myrtle wax, candleberry wax, and bayberry tallow, has for some years formed to some extent an article of commerce in this country. It occurs abundantly as a white incrustation on the small globular berries of the plant. These berries being inclosed in bags of coarse cloth and kept immersed in boiling water, the fused wax collects on the surface, and is then poured off into pans to solidify: as thus obtained, it is nearly pure, and in this state passes directly into commerce. It is employed as a lubricant for rubbing surfaces of wood, as a polish for furniture, as a substitute for beeswax in the manufacture of candles, and in medicine. The commercial wax is of various shades of color, from a grayish-yellow to deep green; more hard and brittle than

beeswax; sp. gr. 1.004—1.006; point of fusion very constant at 117°—120° F. Mr. G. E. Moore, of the Sheffield Scientific School, Yale College, has carefully examined the chemical constitution of the myrtle wax; and he is led to conclude that Chevreul's analysis, giving as its components glycerine, stearic, margaric, and oleic acids, must have been performed on an adulterated sample of the article. His own conclusion is that the pure wax consists of palmitin, about  $\frac{1}{3}$  part, the remaining  $\frac{2}{3}$  being free palmitic, with a small quantity of lauric acid—the latter either free or in the state of laurin. He accordingly suggests this body as, to chemists, a convenient source of palmitin and palmitic acid; while, in the arts, its high illuminating power, cheapness, and probable facility of bleaching, recommend it especially as a hardening ingredient in the manufacture of various sorts of candles, including those of paraffine. The abundance and hardy habits of the plant, its thriving upon poor soils unfit for other crops, as near the sea, the slight attention requisite to insure an abundant yield, and the ease of extraction of the wax itself, combine to indicate the preparation of the myrtle wax as a branch of industry which has not yet received the attention it deserves. ("Amer. Jour. of Science," May, 1862.)

*Aniline Colors.*—A very full article on the celebrated colors derived from aniline, or which in other words are products of coal tar, by Mr. Perkin, the original producer of the aniline purple (*mauve*), will be found in the "Amer. Jour. of Science," Sept. and Nov. 1861. By a recent series of researches upon the aniline colors, which no one had previously obtained in a state of purity, Prof. Hoffmann has been able to reduce these to two types (*rosaniline*  $C_{15}H_{10}N_2$ ) and *leucaniline* ( $C_{15}H_{11}N_2$ ), which thus bear to each other the same relation as do the blue and the white indigo. The subject of the aniline colors is one of too great extent and complexity to bear condensation within a limited space. For the latest information respecting the composition of these coloring matters, their relation to other products obtained from coal (including the various hydrocarbons), their production, and use in dyeing, the reader is referred to the article above cited; to Prof. Hoffmann's recent paper on the subject, in the "Philos. Magaz.," Dec. 1862, Supplement; and to a report of a lecture by him before the Royal Institution, copied in the "Scientific American," Sept. 20, to Oct. 4, 1862.

*Parkesine.*—The basis of this new composition, articles manufactured from which attracted some attention in the Exhibition of 1862, is a mixture in certain proportions of castor oil, collodion, and chloride of sulphur. With these may be combined certain resins, gums, or earthy matters, according as a flexible, plastic, or hard and rigid material is desired, and also matters imparting the required colors to the mass. The mixture of the principal ingredients results in a sort of combination, and almost

immediate solidification takes place. The product can be applied to nearly all the purposes for which the vulcanized India rubber and gutta-percha are already employed, and has besides some advantages of its own. It appears to be more indestructible than those substances, and in some of its preparations excessively hard, quite as much so as iron; and while in thin plates it is perfectly transparent, and can be made to take transparent colors, by the use of certain others it is made wholly opaque. It resists moisture, and has high insulating properties. It is already made into buttons, combs, knife handles, medallions, and other like articles; and the specimens look well, while they appear to be quite indestructible, except by fire. It can be applied as a varnish, transparent or colored, and which becomes perfectly hard and impervious to moisture. The name is from that of the inventor, Mr. Parkes.

*Australian Oils and Resins.*—Mr. J. W. Osborne exhibited before the British Association, 1862, thirty-five specimens of oils, from indigenous trees and plants of Australia, and all of which he regarded as possessing valuable properties, for uses in medicine, or as solvents of resinous materials in varnishes, and for purposes of illumination. Of those serving the last named purposes, many are well adapted to high latitudes—burning in lamps for paraffine oil, with a very white and clear light, and being safe, since they ignite with some difficulty. The trees yielding these products cover an area of not less than 12,000,000 acres. Among them the *Eucalyptus amygdalina*, a very large forest tree, bears leaves which, with the twigs they are on, yield in the green state 8 pints of oil to 100 lbs. of the material. Mr. Osborne also described resins from the *Eucalyptus*, *Callitris*, *Xanthorrhœa*, and various species of *Acacia*.

*Organic Alkaloids*—new method of detection and preparation.—The organic alkaloids are easily soluble in hot amylic alcohol, while their hydrochlorates are so insoluble in this that they may be separated from the amylic solution by shaking this with water containing hydrochloric acid in solution. Erdmann and Von Uslar accordingly prepare the alkaloids by extracting with hydrochloric acid, treating the extract with ammonia to set free the bases, and evaporating. The alkaloid may then be dissolved in hot amylic alcohol, and the solution being shaken with water containing hydrochloric acid, the result is a watery solution of the pure hydrochlorate, while fatty and coloring matters remain dissolved in the amylic alcohol, which may be mechanically removed from the watery layer. (*Ann. der Chem. und Pharm.*, cxv, p. 12.)

*Refining Sugar.*—It has been usual with sugar refiners to correct the acidity likely to appear in the clarified syrup or mother liquor at a certain stage of the refining process, as after the separation of the first crop of crystals, and which is due to formation of saccharic

acid ( $C_6H_7O_7$ , HO), by addition of lime water or milk of lime. The lime base being permanent, however, remains as an impurity in the solution, and as such requiring subsequent removal. Mr. Edward Beanes, of Havana, Cuba, has patented a process in which he substitutes for the lime compound the use of liquid ammonia. The quantity, varying in different cases, should be sufficient in each to keep the syrup neutral, and so prevent the formation of uncrystallizable sugar; the chief advantage consisting in the fact that the ammonia is a volatile base and, hence, eventually removable by heat. The liquid ammonia also serves, being introduced in such quantities as may be requisite, to correct the acidity of crude syrup or molasses, in the manufacture of sugar from these.

*Detection of Picrotoxine.*—The seeds of the *Menispermum Cocculus*, known in commerce by the name of *Cocculus Indicus*, or popularly as "fish berries," contain several active organic bodies. One of these, picrotoxine, is eminently poisonous, and in small doses, it is asserted, possesses an intoxicating quality. Hence, its use is believed to be common in the adulteration of ale and beer—a small addition of the berries to the fermenting mash enabling the brewer to dispense with a large amount of the malt he must otherwise consume. Mr. J. W. Langley believes that he has found a simple and sure test for the presence of picrotoxine; namely, in the bright reddish-yellow color produced in a solution or mixture containing this substance, when, after adding to the mixture 3 or 4 times the quantity of nitrate of potash that there is of substance to be examined, and then barely sulphuric acid enough to moisten the mass, enough of a strong solution of caustic potash or soda is finally introduced to render the whole quite alkaline after neutralization of the acid. The color is strongest at first, and is not permanent. Sugar or strychnia in the mixture, causes the color to be a brownish-yellow; so that these substances, when present, need to be first removed. By the test, the  $\frac{1}{1000}$  of a gramme of the poison has been detected; and in malt liquors into which it was purposely introduced, its presence was readily determined, as also in the membranes of the stomach of a cat poisoned with it, and apart from the contents of that organ, the animal having been killed while the process of absorption was going on. A liquid to be examined for picrotoxine should first be rendered acid, then shaken with ether, and the residue after evaporation examined with the microscope for small prismatic crystals. If such be present, test as above stated. ("Amer. Jour. of Science," July, 1862.)

*Oxygenated Beverages.*—M. Maumené, Professor of Chemistry at Rheims, the centre of manufacture of champagne wines, has been conducting a series of experiments in the way of forcing into wines oxygen gas under a pressure of 7 or 8 atmospheres. When the wine is so old as no longer to give a deposit, the oxy-

gen produced no chemical change in it, though retained for nearly a year; the acidity of the wine was not increased, nor its taste changed. Such wine is more sparkling, and opened disengages oxygen in such quantity as to rekindle an extinguished taper. The wine, however, a little while after being drunk, produces a very sensible heat, and a general and peculiar agreeable sensation. Even ozonized oxygen did not acidify wine. Maumené has also charged wine with protoxide of nitrogen (laughing gas), and the beverage possessed in high degree the exhilarating property of that gas when inhaled. He has even caused water, under 8 atmospheres, to take up oxygen sufficient to render it strongly effervescent; and he was led to conclude that the drinking of such water improved the functions of respiration and digestion.

**Preservation of Meats.**—In the *Cosmos* is found an account of the process of M. Peligot for preserving meats, by introducing into an opening made with a trocar into some suitable part of each piece, a small metallic tube which terminates a longer flexible tube reaching down from a reservoir some 25 to 35 feet above, and which contains the prepared solution of preservative salts: the liquid pressure due to such a height forces the solution into and uniformly through the meat—the pieces meanwhile lying in another solution or pickle bath, which by external pressure prevents the escape of the liquid infiltrated. After a few days, the pieces are removed from the bath, dried in a moderately warm current of air, and then smoked: the whole loss of weight is about 18 to 20 per cent. A ham is in this process perforated to the bone, near the small end; and pork is more improved by the preparation than beef. The process preserves much better the juices and aroma of the meat, than does the ordinary method of pickling, while it can be so regulated as to prevent the entrance of too much salt, and it does not harden the fibres and reduce their nutritive value to near the extent that occurs in ordinary salted meats.

**Rendering Fabrics Non-inflammable.**—The many painful instances of death by burning, which have occurred since the incoming in ladies' dress of the present style of expanded skirts, have resulted in calling the public attention strongly to a consideration of the means of rendering the fabrics of ladies' and of course children's dresses non-inflammable. By this is implied the saturation of the material with some chemical which shall retard its burning, and at least prevent its being rapidly consumed in a blaze or flame; since to render such fabrics "incombustible," or totally incapable of burning, is as yet a thing wholly impracticable. Among the means which have been proposed for the former purpose, are the steeping of the fabric just before its final drying preparatory to ironing, in a solution of chloride of zinc, or of sulphate of ammonia, or of tungstate of soda, or of common salt. By one writer it is stated

that the common salt, while not so liable to injure certain colors as are the other articles, is equally efficacious for the purpose intended.

In manufacturing starch from rice, Mr. T. Redwood, of London, adds to the starch liquor an acid solution of chloride of zinc; the starch compound being then dried and reduced to powder, is ready for use. The clothes starched with this compound are said to be rendered in a high degree non-inflammable, while their surface also takes in ironing a superior polish. For further applications of chemistry, see ILLUMINATION.

**Awards at the Exhibition of 1862 for American Chemical and Allied Products.**—The following are the awards made by the juries having in charge, according to the division made in the articles exhibited, the subjects of the first three classes or departments:

**CLASS No. 1: Mining, Metallurgy, and Minerals.**—J. Mosheimer received the Council medal for his collection illustrating the newly explored mineral wealth of the Territory of Nevada. T. Meads, honorable mention for fine collection of native copper and silver, from Lake Superior; New Jersey Zinc Company, honorable mention for fine spiegel iron, produced from franklinite.

**CLASS No. 2: Chemical Products.**—Medals to Glen Cove Starch Company, samples of starch; for the excellent quality of products; H. G. Hotchkiss, wintergreen oil; Kingsford, silver-gloss starch; F. S. Pease, for petroleum, benzole from petroleum, coal-tar oil for illumination and lubrication. In a subdivision of the same class, the Philadelphia College of Pharmacy received a Council medal for a fine collection of North American vegetable drugs, and preparations made from them.

**CLASS No. 3: Substances Used for Food.**—Glen Cove Starch Company, medal for maizena or corn starch used for food; exceedingly excellent for food. Hecker Brothers, medal for flour; excellence of quality. Stebbins and Co. receive honorable mention for good flour, and J. Waddell, honorable mention for good quality of Indian corn.

**CHILI**, a republic of South America, situated between lat. 25° 22' and 43° 30' south, and between long. 70° and 74° west. It is bounded on the north by Bolivia, on the east by Patagonia and the territory of the Argentine Republic, on the south and west by the Pacific Ocean. It has a length from north to south of about 1,150 miles, while its breadth varies from about 80 to 130 miles. The last official census, which was taken in 1854, gave the following results as to area and population:

PROVINCES.	Inhabitants.	PROVINCES.	Inhabitants.
Atacama.....	50,690	Concepcion.....	110,291
Coquimbo.....	110,569	Arauco.....	48,466
Aconcagua.....	111,504	Valdivia.....	29,298
Valparaiso.....	116,043	Chiloe.....	61,586
Santiago.....	272,489	Lanquibue.....	88,260
Colchaqua.....	192,704	Colony.....	....
Talca.....	79,488	Magallane.....	158
Maule.....	166,242		
Nuble.....	100,792	Total, 1854.....	1,436,130

The next census will not be taken until 1864, but according to a reliable estimate, made in 1857, the population in that year amounted to about 1,600,000. The northern frontier is still an object of controversy between Chili and Bolivia; the latter demanding the extension of its southern frontier to lat. 25° S.; while Chili claims possession of all the territory as far as lat. 21° 48' S.

On the south, Chili lays claim to all the eastern coast as far as the Straits of Magalhaens, but its possession is only nominal. Its claims have been especially resisted by the Indians of the province of Araucania, a country which in its manners, its customs, its organization, and its local government has remained as thoroughly Indian as it was at the time when the Spaniard Ervillá made it the subject of his epic. It has always been in a degree independent, and the successive governments of Chili have in vain attempted to complete its subjection. At the beginning of the presidency of Mr. Pérez, who was inaugurated in September, 1861, another attempt was made to enter into negotiations with the Araucanians. The governor of Nacimiento was charged with sending commissioners to the Indians, in order to convoke their chiefs to a conference, but the Indians refused to come, and the chief cacique, Guentecol, wrote to President Pérez a very haughty letter, which indicated anything but a disposition to submit. Suddenly the controversy between Chili and the Araucanians took a singular turn. A Frenchman, M. de Tounens, who lived among the Araucanians, succeeded in making them believe that he would be able to defend them against Chili, and was consequently elected by them king under the name of Aurelie Antoine I. The new king formed a constitution, and although his movements at first created a great deal of merriment in Chili, the government now found it necessary to devise means to get rid of him. Early in 1862 disguised Chilians were therefore sent into Araucania, who reached the place where the king held his court; a policeman seized him, put him on his horse, and in full gallop escaped with him from the pursuing Indians. He has since been confined in a prison of Chili.

Chili is celebrated for the tranquillity which it has enjoyed since the establishment of the republican form of government. Subsequent to the adoption of the constitution in 1833 there have been only three presidents, each one serving two terms (of five years each). The last presidential election took place in 1861. On June 25th, the people chose electors; these met on July 25th for the election of the President; on August 30 the assembled Chambers opened the returns and officially announced the result, and in September the President elect, José Joaquín Pérez, was solemnly inducted into his office by his predecessor. Mr. Pérez had been elected unanimously; of 216 electoral votes, 214 were cast for him, and the two electors who were absent, declared that they would

likewise have voted for him. The new President belongs to one of the first families of the country, and is about 60 years old. He commenced his political career, in 1829, as secretary of legation in France. A few years later, when Chili was involved in war with the new Peru—Bolivian Confederacy—Pérez was sent to Buenos Ayres to effect an alliance with the Dictator Rosas. He has since been successively, councillor of state, minister of finances, of the interior, of foreign affairs, president of the Chamber of Deputies and of the Senate.

The aim of the new President was to effect a fusion of the conservative and the liberal parties. He therefore proposed to the Chambers a law of amnesty, which was adopted by them unanimously on Oct. 7th and 8th, 1861. His cabinet consisted partly of conservatives and partly of liberals. This conciliatory policy was, however, attacked by partisans of both parties, and led, on June 20th, 1862, to a change of the cabinet; yet the new one was again composed of conservatives and liberals.

CHINA. See TAI-PING REBELLION.

COCHIN-CHINA, or the EMPIRE OF ANAM, is a state occupying the eastern portion of the peninsula of Farther India, in S. E. Asia. It is separated from China on the north by a prolongation of the Himalaya Mountains, and its northern boundary nearly follows the line of the Tropic of Cancer; on the east the Gulf of Tonquin, or Tong-king, as the natives call it, and the Chinese Sea wash its shores, the latter forming also its southern boundary; on the west the Laos Mountains separate it from the Kingdom of Siam, and at the N. W. from the Burmese Empire. Its population is about 13,000,000. Its area is probably not far from 320,000 square miles. Aside from the mountain ranges which form its northern and western boundaries, a chain of considerable height, the mountains of Moi or Anam range, traverse the whole length of the country from Tonquin to the river Saigon, following the trend of the coast, and at a distance of fifty to sixty miles from it, and spurs from the Laos Mountains extend eastward to the valley of the Me-kong river, in the interior. The country is everywhere well watered; from the eastern slope of the mountains of Moi, numerous short streams, rarely navigable, find their way to the Gulf of Tonquin and the Chinese Sea; while the interior is abundantly irrigated by the great Me-kong, or Cambodia river, one of the great rivers of S. E. Asia, and its affluents. This river, which is also the outlet of the great lake of Tali-sab in Siam, enters the Chinese Sea and the Gulf of Siam by ten or twelve principal, and many small channels, and has formed an immense delta of rich though marshy soil, forming nearly one half of the state of Lower Cochin-China. This delta yields in great profusion rice, sugar, and other semi-tropical and tropical products, while the mountainous districts furnish vast quantities of the finest ship timber,

which is in demand for the construction of ships and junks, the Anamese being the shipwrights of southeastern Asia. The empire is divided into four principal states: Tonquin, or Tong-king, on the north; Cochin-China Proper, on the east; Lower Cochin-China, on the south, and extending above this in the centre and southwest, Cambodia. The interior, among the mountains and along the shores of the Cambodia or Me-kong river, is peopled by the Laos, Moi, Kuy, and other tribes, the aborigines of the country, who have been driven back and reduced to a state of partial subjugation by the successive invaders who have possessed themselves of the shores of the country. The Anamese, the ruling people of the coast, are a mixed race, composed of Malays, Chinese, Siamese, and Peguans, the Malays, perhaps, predominating. The religion of the country is nominally Buddhism, but it has not a very strong hold on the people; the mountaineers are mostly pagans, and adhere to some of the earlier forms of idolatry. In the 17th century the Jesuit missionaries introduced the Roman Catholic faith here, and at the close of the last century it had attained a great preëminence, the Emperor Gya-Long having become a convert, and more than 500,000 of his people having professed Christianity. A Roman Catholic hierarchy was established in the country, and consisted of seven bishops, seven assistant bishops, sixty European missionaries, and 250 native priests. The successors of Gya-Long, from some cause, have not sympathized with Roman Catholic Christianity, and the last three emperors have persecuted it with great virulence. The present emperor, Tu-Duc, who is represented as a tyrannical and cruel ruler, though possessing considerable astuteness, has distinguished himself by his efforts to expel Christianity from the country. The native Christians have been tortured and massacred, their priests executed, and the European missionaries in many instances put to death. Partly in consequence of the cruelties thus inflicted on their missionaries, and partly from the determination on the part of France to secure to herself oriental possessions, which, in their extent and value, should equal those of Great Britain, Spain, and Holland, an expedition was sent out in 1858 from France, and joined by a small Spanish contingent, to redress the wrongs of which the French and Spanish missionaries had complained. The expedition captured Touran, a town on the coast of Cochin-China Proper, about thirty miles below Hue, the capital of the empire; and in 1859, after a siege and battle of some severity, took Saigon, an important town on the river of the same name, in lat. 10° 50' N., in Lower Cochin-China. The Emperor Tu-Duc, however, was obstinate in his resistance, and neither made nor admitted any overtures for peace, and when the war in China had called off a portion of the French force, he promulgated edict after edict, each bearing with

greater severity than its predecessor on the unfortunate Christians, whom he had evidently determined to exterminate; and having regained possession of Touran, he threatened Saigon, declaring his intention of driving the vagabond barbarians from his shores. This could not be permitted, and in January, 1861, the French Vice-Admiral Charner set sail from Woo-Sung, China, and arrived in the harbor of Saigon on the 11th of February. He had at his command an effective force of about 8,000 men. In the next thirteen days he had attacked and carried by storm the immense and strongly-fortified camp of *Ki-Hoa*, with a loss of twelve killed, and 225 wounded, and had driven the Anamese out of the province of Saigon. He next proceeded to attack the fortified town of Mytho, situated on the Me-kong or Cambodia river, the most considerable place in the possession of the Emperor Tu-Duc, in Lower Cochin-China. After a sharp action of three days, this important post was taken on the 10th of April, 1861, and with it a number of war vessels of large size and great quantities of guns, ammunition, and stores. Colompe, a town farther up on the Me-kong, was soon after taken, as well as several villages of smaller size, and trade was opened by proclamation between Saigon and foreign ports. On the 29th November, 1861, Vice-Admiral Charner was succeeded by Rear-Admiral Bonard, who found it necessary to assume at once the offensive, as Tu-Duc, irritated by the losses he had suffered, and the threatened insurrection of a portion of his subjects, had killed his principal generals, and was becoming daily more desperate and fierce. On the 14th of December Rear-Admiral Bonard attacked *Bien-hoa*, an important place, lying on the Long-tao river, where the Anamese had accumulated a large amount of stores, and, after a four days' siege, captured it; and, as the fruits of his victory, obtained eleven war junks, four large shallops, 50 cannon, and large quantities of rice and other stores. The next object of attack was Ving-long, an important citadel, some distance above Mytho on the Me-kong river, the most important position held by the Anamese in the south of the empire. The siege commenced on the 20th of March, 1862, and on the 28d the place was carried; sixty-eight large cannon were captured, a magazine, 488 feet in length, filled with rice, a cannon foundry, mortars, powder, saltpetre, &c. This blow so completely broke the power of the Emperor Tu-Duc that he almost immediately made overtures for the cessation of hostilities, and on the 6th of June, 1862, a treaty of peace was signed, by which the provinces of Saigon, Bienhoa, and Mytho were ceded to France; three ports of Tong-king were opened to commerce; the other provinces of Lower Cochin-China not ceded to France were to receive only such number of troops as the French Government should permit; Christianity was to be tolerated, and the Christians protected in their lives, persons, and property throughout the em-

pire. This treaty was forwarded to France for confirmation by the Imperial Government. In December, 1862, the Anamese rose in insurrection, and on the 17th of that month penetrated into the interior of the fort of Saigon, but were repulsed with heavy loss. On the 27th they attacked Mytho, but were forced to retreat with 225 killed.

COLT, SAMUEL, the inventor and manufacturer of Colt's revolver, was born at Hartford, Conn., July 19, 1814; died in that city Jan. 10, 1862. His ancestors were among the early residents of Hartford; his father was a man of great energy, intelligence, and enterprise, at first a merchant, and afterward a manufacturer of woollen, cotton, and silk goods. His mother was a lady of superior ability and talent, the daughter of Major John Caldwell, an eminent banker of Hartford. The son had the opportunity of acquiring a good English education in the schools of his native city, but his energetic and restless spirit led him, even when a child, to prefer the workroom to the schoolroom. At the age of ten years he entered his father's factory, and remained there with occasional intervals spent on a farm and at school, till his 14th year, when he was sent to Amherst, Mass., for the further prosecution of his studies. Here, again, the restless spirit which had animated him from childhood, appeared; he ran away from the school, and before his friends knew anything of the matter, he had, in July, 1827, shipped as a boy before the mast, on the ship *Corvo*, Captain Spalding, on an East India voyage. From this voyage, though subjected to severe hardships in its course, young Colt returned, no whit subdued in spirit, enterprise, or resolution. After a short apprenticeship in his father's factory, at Ware, Mass., in the dyeing and bleaching department, under the tuition of Mr. William T. Smith, a scientific man and highly practical chemist, where, with great readiness, he familiarized himself with the leading principles of chemistry, and became a dexterous and skilful manipulator, he again left home, to seek his fortune. Though but 17 or 18 years of age, and with but a meagre education, either in chemistry or anything else, yet under the assumed name of Dr. Coult, he traversed every state, and visited almost every town of 2,000 inhabitants or over, in the Union and British N. America, lecturing on chemistry, and, owing mainly, no doubt, to his skill and success as an experimenter, drew full houses almost everywhere. The profit from these lectures, which was very considerable, during the two years which followed, was not squandered, as it would have been by many a youth under similar circumstances, but every dollar beyond his actual necessities was devoted to the prosecution of the great invention which is indissolubly connected with his name, and the germ of which he had already devised while on his voyage to Calcutta with Captain Spalding. The first model of his pistol made in wood in 1829, with the imperfect tools at his command,

while he was a sailor boy on board the *Corvo*, is still in existence. The money acquired by his chemical lectures enabled him to manufacture other models, which, in their practical results, exceeded even his own most sanguine expectations, and in 1835, when only 21 years of age, he took out his first patent for revolving firearms. Before obtaining his patent in this country he visited England and France, and secured the protection of their patent laws. At this time, and, indeed, for several years after, he was not aware that any person before himself had ever conceived the idea of a firearm with a rotating chambered breech. On a subsequent visit to Europe, while exploring the collection of firearms in the Tower of London and other repositories of weapons of war in England and on the Continent, he found several guns having the chambered breech, but all were so constructed as to be of little practical value, being far more liable to explode prematurely and destroy the man who should use them than the objects at which they might be aimed. Unwilling, however, to seem to claim what had been previously invented, he read before the Institution of Civil Engineers in England (of which he was the only American associate), in 1851, an elaborate paper on the subject, in which he described and illustrated, with appropriate drawings, the various early inventions of revolving firearms, and demonstrated the principles on which his were constructed. But to return to our narrative: patents having been issued in England, France, and the United States for the revolver, as it was called, he succeeded, despite the croaking of many of his acquaintances, in inducing some New York capitalists to take an interest in it, and a company was formed at Paterson, N. J., in 1835, with a capital of \$300,000, under the name of the Patent Arms Company. His next step was to prevail upon the U. S. Government to adopt the arm. For a long time he was foiled in this: the officers of the Government and of the Army and Navy frowned upon the invention: they objected to the percussion cap, to the supposed liability of the arm to get out of order, to the tendency of several of the charges to explode at the same time, and to the greater difficulty of repairing it than the arms in common use. These objections Mr. Colt met by careful explanations, by repeated experiments, and where improvements were possible, by modifications in the construction of the weapon. The company with which he was connected expended about \$300,000 in the manufacture of the arms and in improvements in them, and in the machinery for their manufacture. In 1837, during the Florida war, the officers of the army were baffled in their attempts to drive the Indians from the Everglades by their skill in the use of the rifle. At length a few of the troops, under the direction of Lt.-Col. (afterward Gen.) Harney, were armed with Colt's revolvers, and their success was such that more were at once ordered, and the



Indians were easily disheartened and defeated when they found that their enemies could fire six or eight times without reloading. This triumph of his arms was, however, a misfortune to the ingenious inventor, for the speedy conclusion of the war deprived him of a market. In 1842, the Patent Arms Company were forced to suspend, and from that time till 1847 none of the repeating firearms were manufactured. Meantime, the market was entirely drained of them by the demand from Texas and the Indian frontier. In 1847, the Mexican war having commenced, Gen. Taylor, who knew their value from his experience in the Florida war, sent Captain Walker, of the Texan Rangers, to Col. Colt to procure a supply. There were none to be had; the colonel had parted with the last sample to one of the Texan Rangers, and when the Government ordered one thousand more, on his offer to make them for \$28,000, after advertising in vain for one to serve as a model, he was compelled to make a new model, and in so doing, incorporated into it some improvements which the experience of military officers suggested. This first thousand were made at an armory temporarily hired at Whitneyville, near New Haven, Conn. Other orders following immediately on the completion of the first, Col. Colt procured more commodious workshops at Hartford, commenced business on his own account, and filled the orders with promptness. The extraordinary emigration to California and afterward to Australia greatly increased the demand for the revolvers, and assured the permanency of the business. Finding that more room and greater facilities for manufacturing were required, he planned in 1852, and subsequently executed, the gigantic project of erecting an armory, unequalled in the world in extent and perfection of machinery, and under circumstances which would have deterred most men from the effort. Within the corporate limits of the city of Hartford, and south of the Little or Mill river, lay a tract of meadow, of about 250 acres in extent, which, owing to its being flooded by the annual freshets of the Connecticut river, was available only for grazing purposes, and even for them only at certain seasons of the year. This tract he purchased, and surrounded with a dike or embankment, about two miles in length, one hundred and fifty feet wide at the base, from thirty to sixty at the top, and from ten to twenty-five in height. The strength of this dike having been tested by a severe freshet, and it having been further protected by covering the sides with willows, he erected within it his armory, of Portland stone, consisting of two main buildings connected by a central building, the whole being in the form of the letter H. The front parallel is 500 by 60 feet, the rear parallel 500 by 40, and the central building 250 by 50 feet; the front parallel and central building are three stories in height; connected with these are other buildings for offices, warerooms, watchmen's houses, &c. In 1861 a second building

of the same size as the first was erected, the great increase in the demand for his arms rendering more room for their manufacture indispensable. In this establishment there is ample accommodation for the manufacture of 1,000 firearms per day, being more than double the capacity of the national armories at Springfield and Harper's Ferry united. The number made the present year is about 120,000, while the two U. S. armories together, in 1860, made about 85,000. A part of the establishment is devoted to the manufacture of Col. Colt's machinery for making these firearms elsewhere, which has already supplied a large portion of the machinery for the armory of the British Government at Enfield, England, and the whole of that for the Russian Government armory at Tulin. On the land enclosed by the dike he also erected numerous dwellings for his employés, and warehouses for other kinds of business, the entire expenditure upon the grounds and buildings amounting to more than \$2,500,000. On the first terrace beyond the river valley, overlooking this busy hive, he erected his own palatial residence. After establishing himself at Hartford, Col. Colt repeatedly visited Europe, and his arms being extensively used by many of the European Governments, especially those of Russia and Great Britain, he was received with great attention, and several times had occasion to explain his views respecting firearms before the most eminent military authorities, and even the crowned heads themselves of those countries. In 1856 he visited Russia, with his family, and was present, as an honored guest, at the coronation of Alexander II.

Soon after the Mexican war, the suggestions derived from the use of these arms by the military forces, led to extensive improvements in their construction, which were then patented, and to their adoption by the Government of the United States as a regular weapon for the army. Subsequently, long service in the field in the Crimean and Indian campaigns suggested still further improvements and simplifications in the construction, which were also secured by patent, and which render the arm comparatively perfect and certainly superior in efficiency to any other firearm in existence. From almost all the Governments of Europe, as well as from several of the Asiatic monarchs, he received orders of merit, medals, diplomas, rings, and other tokens of their esteem and appreciation of his great invention.

All the accessories of these arms, balls, cartridges, bullet moulds, powder flasks, lubricators, &c., &c., are manufactured at the armory, and most of them, as well as the greater part of the machinery for manufacturing the arms, were the invention of Colonel Colt, or the development of his suggestions, by some of his skilful workmen. Amid his other cares, the intellectual and social welfare of his numerous employés were not forgotten. Few mechanics are favored with as convenient residences as those he has erected

for them; and a public hall, a library, courses of lectures, concerts, the organization of a fine band of music, formed entirely from his own workmen, to whom he presented a superb set of musical instruments, and of a military company of his operatives, provided by him with a tasteful uniform, and otherwise treated with great liberality, were among the methods by which he demonstrated his sympathy with the sons of toil.

But Col. Colt's claims to distinction, as an inventor, do not rest solely on his inventions of firearms. His *submarine battery*, the powers of which have been repeatedly tested in the presence of distinguished naval officers, is probably the most destructive weapon of defence, and the most effective protector of harbors against maritime attacks ever devised. Among the inventors of the submarine telegraph cable, too, a distinguished place belongs to him, he having laid and operated with perfect success, in 1843, such a cable from Coney Island and Fire Island to the City of New York, and from the Merchants' Exchange to the mouth of the harbor. This cable was insulated by being covered with a combination of cotton yarn with asphaltum and beeswax, and the whole enclosed in a lead pipe, gutta percha being then unknown. A portion of it is still in existence. He married in 1855 Miss Elizabeth Jarvis, daughter of Rev. Dr. Jarvis, of Portland, Conn., who survives him.

**COMMERCE.** The commerce of the United States for the past year has been, through the operation of the war, shorn of its proportions, but, under the circumstances, prosperous. The leading features of the year 1861, when the several relations of trade were violently broken, and produce, turned from its accustomed markets, was suddenly forced into new channels, have, in 1862, been more strongly marked, exaggerated as they are by the growing evils connected with the currency and the damage done on the ocean by cruisers of the enemy. The nations of Europe, as well as the English, began at the close of 1861 to feel the want of cotton in a most urgent manner, and their representatives at Washington expressed to the Government informally the desire for some relaxation of the blockade which should permit the egress of that article. This desire induced greater exertion on the part of the executive to hasten a movement of troops, which should bring within the control of the national arms such tracts of country as allowed a reopening of the trade. The advance into Kentucky and Tennessee in January and February, opening the Cumberland and Tennessee rivers, on these grounds excited great hopes, which were, however, not fulfilled. The Confederates when driven back ordered the destruction by fire of all cotton and tobacco likely to fall into the hands of the Federals, and this was carried out to some extent. When the Tennessee region was "reopened," therefore, very little cotton was found. The disposition, that might have

existed on the part of the planters to bring forward their crops was checked by the want of protection to private interests, and the complicity of commanders in private cotton speculations in a manner incompatible with general business interests. There was a great want of money in all that region, and the good prices that cotton commanded in specie at first produced a little business, which drew upon the resources of the West for specie to meet its requirements. This growing confidence was suddenly blasted, by an order from Gen. Curtis that specie should not be paid for cotton, as if specie could have any more important function than to procure that cotton, for the want of which so many mills were idle, and so many persons out of employ. The order was subsequently rescinded, but the mischief was done, and the cotton trade killed. As the troops progressed, the Secretary of the Treasury issued special licenses, March 29th, for commercial intercourse under the Act of July, 1861, which prohibits shipments from those ports of the United States heretofore declared by the President to be in insurrection, without a written permit. The licenses did not extend further than Nashville and intermediate points. Nothing shipped under them was to be disposed of to persons in arms against the United States, or to others furnishing them aid and comfort. An order was also issued for the restoration of the mail service between Boonesville, Mo., and Independence, which was suspended in December, in consequence of the war. Soon after the Secretary of the Treasury issued instructions to the Treasury agents, collectors and surveyors, on the Ohio and Mississippi rivers, dispensing with applications to the Secretary for licenses to trade, and authorizing the shipment of all goods not intended for aid to the enemy, to all places occupied by Federal forces in the valley States. A little renewed business followed these regulations, but the regions designated in them, being deprived of their produce, had no means of payment. The little cotton bought by the army speculators did not add to the business means of the section. Down to the 11th of May, permits were granted for the shipment from Nashville of 3,512 bales of cotton. To this amount may be added from 50 to 100 bales shipped by outsiders. The whole amount shipped from the 11th of March, when trade was opened, may be set down at not less than and probably something over 3,600 bales. From two to three thousand bales were burnt by the Confederate troops—chiefly in Giles county, Tenn.

At the close of April the expedition to the Atlantic coast had opened some ports, but failed to elicit any trade. The fall of New Orleans, however, awakened the greatest hopes, and the occasion was at once seized by the Government to invite trade. Mr. C. L. Lathrop was appointed collector at that port, and the following circulars were addressed to the foreign ministers at Washington, announce

ing the reopening of communication with reconquered Southern localities :

DEPARTMENT OF STATE, WASHINGTON, *May 2, 1862.*

SIR : I have the honor to state for your information, that the mails are allowed to pass to and from New Orleans and other places which, having heretofore been seized by insurgent forces, have since been recovered, and are now reoccupied by the land and naval forces of the United States. It is proper, however, to add that a military surveillance is maintained over such mails, as far as the Government find it necessary for the public safety. I am, sir, your obedient servant,  
WM. H. SEWARD.

DEPARTMENT OF STATE, WASHINGTON, *May 5, 1862.*

SIR : I have the honor to state for the information of your Government, that a Collector has been appointed by the President for New Orleans, and that the necessary preparations are being made to modify the blockade so far as to permit limited shipments to be made to and from that and one or more other ports, which are now closed by blockade, at times and upon conditions which will be made known by proclamation.

I am, sir, your obedient servant,  
WM. H. SEWARD.

A great number of vessels at once left the northern ports for that city with good outward bound cargoes. The President then issued a proclamation declaring that the blockade of the ports of Beaufort, Port Royal, and New Orleans shall so far cease and determine from and after the 1st of June, 1862, that commercial intercourse with these ports, except as to persons and things and information contraband of war, might from that time be carried on, subject to the laws of the United States, and to the limitations and in pursuance of the regulations which were prescribed by the Secretary of the Treasury, as follows :

*Regulations relating to trade with ports opened by Proclamation.*

TREASURY DEPARTMENT, Monday, *May 12.*

*First.* To vessels clearing from foreign ports and destined to ports opened by the proclamation of the President of the United States of this date, namely Beaufort in North Carolina, Port Royal in South Carolina, and New Orleans in Louisiana.

Licenses will be granted by consuls of the United States, upon satisfactory evidence that the vessels so licensed will convey no person, property, or information contraband of war, either to or from said ports, which licenses shall be exhibited to the collector of the port to which said vessels may be respectively bound, immediately on arrival, and if required to any officer in charge of the blockade; and on leaving either of the said ports every vessel will be required to have a clearance from the collector of the customs according to law, showing that there has been no violation of the conditions of the license. Any violation of the said conditions will involve the forfeiture and condemnation of the vessel and cargo, and the exclusion of all parties concerned from any further privilege of entering the United States during the war for any purpose whatever.

*Second.* To vessels of the United States, clearing coastwise for the ports aforesaid, license can only be obtained from the Treasury Department.

*Third.* In all other respects the existing blockade remains in full force and effect as hitherto established and maintained; nor is it relaxed by the proclamation except in regard to the ports to which the relaxation is by that instrument expressly applied.

(Signed.) S. P. CHASE, Secretary of Treasury.

The appointment of Gen. Butler to the command at New Orleans was followed by a line

of policy which neutralized the commercial results anticipated from the possession of the port. The Secretary of State wrote to the minister, Mr. Adams, at London, July 28, 1862, as follows :

We shall speedily open all the channels of commerce, and free them from military embarrassments, and cotton, so much desired by all nations, will flow forth as freely as heretofore. We have ascertained that there are three and a half millions of bales yet remaining in the region where it was produced, though large quantities of it are yet unginmed and otherwise unprepared for the market. We have instructed the military authorities to favor, so far as they can consistently with the public safety, its preparation for and despatch to the markets, where it is so much wanted; and now, notwithstanding the obstructions which have necessarily attended the reestablishment of the Federal authority in that region against watchful and desperate public enemies, in whose hands the suppression of the cotton trade by fire and force is a lever with which they expect to raise up allies throughout Europe, that trade has already begun to revive, and we are assured by our civil and military agents that it may be expected to increase fast enough to relieve the painful anxieties expressed to us by friendly nations. The President has given respectful consideration to the desire informally expressed to me by the Governments of Great Britain and France for some further relaxation of the blockade in favor of that trade. They are not rejected, but are yet held under consideration, with a view to ascertain more satisfactorily whether they are really necessary, and whether they can be adopted without such serious detriment to our military operations as would render them injurious rather than beneficial to the interests of all concerned. An answer will be seasonably given, which will leave foreign powers in no uncertainty about our course.

It resulted, however, that no renewal of business took place with the interior, and the occupation of New Orleans, from which great hopes were entertained, not only as having direct influence upon the war, but on the means of freeing the 2,000,000 bales of cotton usually delivered at that port, and which would not only have kept alive the 72 northern mills, with their 5 million spindles and 125,000 looms, employing more than 100,000 hands, but would have largely supplied exchange, stopped the outward flow of specie, diminished the distress in England and France, and smoothed the foreign relations of the country, while it would have supplied immense resources to the Government, did not justify those hopes. The causes of the failure to realize these objects changed the whole face of business during the year, and while it made the occupation of the mouths of the Mississippi barren of useful results, added greatly to the exasperation of the South, and led to serious complications with foreign consuls, whose rights and duties became by no means clear in the position in which they were placed. Their functions necessarily brought them in contact with a people under martial law, and whose rights of property depended upon the will of the military commander.

The trade of New Orleans, showing the receipts of the principal articles from the interior, during the year ending 31st of August, 1862, with their total value, is represented in the following table :

Articles.	Amount.	Value.
Alcohol, bbla.....	307	\$18,420
Apples.....	34,127	168,889
Bacon, assorted, hbds. and casks.....	4,073	651,680
"    assorted, boxes.....	681	40,860
"    hams, hbds. and tierces.....	3,420	581,400
"    in bulk, lbs.....	784,399	219,681
Bargain, pieces.....	1,323	19,269
Bale ropa, coils.....	2,456	38,347
Beans, bbla.....	2,098	25,176
Butter, kegs and firkins.....	5,086	201,440
"    bbla.....	322	87,080
Bran, sacks.....	65,746	164,365
Beef, bbla.....	6,561	164,275
"    tierces.....	7,061	211,880
Cotton, bales.....	83,890	1,769,040
Corn, in ear, bbla.....	23,316	44,433
"    shelled, sacks.....	315,652	899,608
Cotton seed.....	253,750	143,313
Cheese, boxes.....	3,941	39,410
Candles.....	5,385	52,650
Dried apples and peaches, bbla.....	1,262	15,144
Feathers, bags.....	51	1,375
Flaxseed, tierces.....	16	400
Flour, bbla.....	331,645	3,661,335
Glassware, packages.....	833	1,915
Hides, number of.....	11,885	35,595
Hay, bales.....	40,573	426,060
Iron, pig, tons.....	59	2,360
Lard, bbla. and tierces.....	6,069	894,435
"    kegs.....	4,290	77,920
Leather, bundles.....	10,840	775,500
Lime, western, bbla.....	37,613	82,836
Lead, pigs.....	1,967	15,736
"    kegs and boxes.....	86	730
Molasses (estimated crop), galls.....	34,982,505	6,703,079
Oats, sacks.....	45,343	174,539
Onions, bbla.....	2,419	16,938
Oil, linseed.....	5	400
"    castor.....	839	23,730
"    lard.....	63,269	632,690
Pork, tierces and bbla.....	11,452	453,030
"    hbds.....	51	4,080
"    in bulk, lbs.....	610,219	132,043
Porter and ale, bbla.....	361	8,610
Packing yarn, reels.....	10	200
Rice, casks.....	23,476	935,992
Rosin, bbla.....	277	1,108
Rum.....	5,839	149,824
Skins, deer, packs.....	58	1,060
Shot, kegs.....	100	67,416
Soap, boxes.....	8,427	33,024
Spirits turpentine, bbla.....	2,716	83,024
Staves, M.....	9	565
Shingles.....	1,475	8,350
Sugar (estimated crop), hbds.....	459,410	25,092,974
Spanish moss, bales.....	500	10,000
Tallow, bbla.....	792	27,720
Tobacco, leaf, hbds.....	1,008	200,600
"    strips.....	60	24,000
"    chewing, kegs and boxes.....	6,966	127,820
Twine, bundles and boxes.....	103	1,520
Wool, bags.....	3,835	231,800
Whiskey, bbla.....	1,769	70,400
Wheat, sacks.....	36,411	218,466
Other various articles, estimated at.....	.....	5,000,000
<b>Total value.....</b>	<b>.....</b>	<b>\$61,510,990</b>
"    in 1860-'61.....	4	155,863,564
"    in 1859-'60.....	4	183,211,254
"    in 1858-'59.....	4	172,952,664
"    in 1857-'58.....	4	167,165,546

the usual routine of commerce, by which the West, in sending produce South, makes exchange with which it pays the cost for goods consumed at the West. There was nearly \$12,000,000 less pork received thence, 3½ millions less tobacco, and 11 millions less corn and wheat—making nearly 27 millions less value for those three articles, of which the West was deprived, and which necessarily diminished its means of purchasing goods; on the other hand, the West was deprived of its usual supplies of sugar and cotton. The receipts of sugar at New Orleans were very large, in consequence of the plantations being within reach of the troops; and there being no other outlet for the crops, the value, even under the extraordinary proceedings of the commanders at that point, reached \$31,796,053. The vessels which sought New Orleans from the North on the opening of the port found no outward cargoes that would pay.

The opening of the ports in North Carolina and South Carolina was not more successful. A small quantity of Sea Island cotton was seized by the troops at Port Royal, and sent forward in gunny bags, unginned and dirty. Attempts made to plant and raise it were unsuccessful. Some efforts to open trade with North Carolina, by sending down assorted cargoes from the North, ended disastrously, and were not renewed. Naval stores, therefore, continued to command a very high price at the North.

The internal condition of the country during the year had much influence upon its external commerce, since a very large proportion of its industry was turned in a military direction, and the accustomed demand for goods and supplies for exports, was greatly interfered with. More than 700,000 men were called into the army and navy during the year, and the number who were engaged in the service of the Government in all departments, was represented at nearly 1,200,000. The accustomed sources of revenue for these persons were changed for Government pay, and this, to the extent of, in round numbers, 500 millions, flowed from the Treasury through the hands of individuals to the support of their families in all the States, satisfying their necessary wants, but somewhat changing the character of the articles consumed, while those usually produced became less abundant. The natural tendency under such circumstances is for prices to rise, and this tendency was accelerated by the paper paid out by the Government in such quantities as to cause it rapidly to depreciate. The first effect of this state of affairs was to induce larger imports, and to diminish exports, causing an outward flow of the precious metals which gave a new impetus to the decline of the currency. Other circumstances combined to push on these effects.

For the first time the trade of the entire year 1862 was confined to the Northern ports, and Baltimore, Philadelphia, Boston, and New York, were the points of exports as well as of imports for the whole country. The exports from

The aggregate shows a decline of more than 100 millions upon the year's business, consisting mostly of cotton, which did not arrive at that port from the interior during its military occupation, since the military commander failed to inspire confidence among the planters in respect to the safety of property. On page 118, "Annual Cyclopædia of 1861," will be found the returns for the years 1860 and 1861—a comparison indicating the vast decline in the receipts of western products, mostly coal and provisions. The blockade of the river cut off

New York represented by far the largest portion of the whole quantities shipped out of the country, and the results of the year's business show a singular reversal in the course of many important items. Thus, last year the national export of cotton, as seen in page 117, "Annual Cyclopsdia, 1861," amounted to \$34,051,488, which amount had been sent out of the country before the blockade became strict. This year the imports of cotton into the port of New York were 70,565 bales, valued at \$6,121,408. The imports of wool were as large. The imports of sugar and molasses figured at nearly 17 millions; tobacco and rice nearly \$3,800,000; so with many other articles that are usually of domestic supply. Guns reached nearly \$10,000,000. The effect of the war was thus to cause a large and unwonted import of certain articles, while the usual medium of payment for imports was not forthcoming. The products of the West indeed formed the basis of the export trade; but the wants of England and Europe were much less than in the previous year; hence the quantities exported realized much lower sums of money abroad, and it is probable, but for the influence of paper money upon the shipments, the amounts would have been much less than they were. The following table shows the leading articles exported as compared with the previous year:

*Exports from New York to Foreign Ports of Certain Leading Articles of Domestic Produce for Eleven Months of the Year.*

ARTICLES.	1861.	1862.
Ashes: Pots, bbls. ....	\$18,608	\$9,508
Pearls .....	8,507	1,580
Beeswax, lbs .....	8,507	1,580
Breadstuffs: Wheat flour, bbls. ....	3,110,646	2,961,518
Eye flour .....	11,907	8,897
Corn meal .....	103,385	132,606
Wheat, bushels .....	23,889,914	25,564,755
Eye .....	1,000,405	1,104,549
Oats .....	1,600,925	210,669
Barley .....	8,927	42,061
Peas .....	189,284	118,819
Corn .....	12,456,265	12,020,848
Candles, mould, boxes .....	75,454	96,701
" sperm .....	17,961	41,894
Coal, tons .....	80,586	80,884
Cotton, bales .....	152,562	24,400
Cottons, domestic, packages .....	55,689	5,892
Hay .....	15,776	46,674
Hops .....	28,377	38,409
Naval stores: Crude turp., bbls. ....	21,571	17
Spirits turpentine .....	18,925	788
Rosin .....	208,061	18,200
Tar .....	26,646	4,601
Pitch .....	8,060	906
Oil, whale, galls. ....	1,196,468	1,554,359
" sperm .....	1,080,328	756,178
" lard .....	110,401	710,885
" linseed .....	85,626	35,640
" coal .....	.....	.....
Provisions: Pork, bbls. ....	116,654	171,809
Beef .....	29,018	82,977
" .....	83,924	27,765
Cut meats, lbs. ....	50,565,782	145,102,758
Butter .....	28,159,391	80,608,285
Cheese .....	40,041,225	89,200,439
Lard .....	47,290,409	126,651,091
Rice, tierces .....	15,867	701
" bbls. ....	15,827	12,148
Tallow, lbs. ....	25,820,335	43,866,920
Tobacco, crude,* packages .....	116,598	118,575
" manufactured, lbs. ....	8,152,484	1,593,044
Whalebone .....	975,075	1,191,907

\* Included in the exports of crude tobacco are 45,850 hogheads.

The quantity of wheat exported in the shape of flour and wheat was equal to 40,000,000 bushels, against 44,000,000 bushels in the previous year, but the prices realized were much less. In provisions the increased export was very large, as was also the case with oils. The new trade which sprang up in petroleum seems to have been greatly developed by the introduction of the article into Europe, and nearly 12 millions of gallons were shipped. The exports for the year were as follows:

Places.	Gallons.	Value.
New York .....	6,788,547	\$2,087,413
Philadelphia .....	2,607,308	529,575
Boston .....	891,616	457,559
Baltimore .....	1,120,000	500,000
Total .....	11,407,366	\$3,524,847

According to the annual statement of the superintendent, in the year 1862 there passed through the ship canal, at St. Mary's Falls, Michigan, which forms the gateway to Lake Superior, \$12,000,000 worth of copper and iron, besides general merchandise to the value of \$10,000,000. The following statement, prepared by the superintendent of the canal, shows the extent and character of this trade more in detail: 543 schooners, aggregating 170,595 tons; 121 propellers, 65,124 tons; and 174 steamers, 124,838 tons—making a total tonnage for the year of 359,612 tons. By this it appears that the whole number of vessels, sail and steam, that passed through the canal last year was 838, with an aggregate tonnage of 359,612 tons. In the year previous there were 527 vessels, sail and steam, with a tonnage of 276,637 tons. At six cents per ton, the rate now collected, the tolls for the last year amounted to \$21,676.72, of which \$14,120 were deposited with the State Treasurer. A careful estimate of the trade of the Lake Superior region for the year 1862 gives the following results: Iron, pig and ore, 150,000 tons; copper, 9,300 tons; general merchandise, 80,000 tons. The iron and copper mines of Lake Superior were never in a more prosperous condition, and there is every reason to believe there will be a large increase of exports in the current year, though the business of 1862 shows an increase of about 50 per cent., compared with the year immediately preceding.

In the early part of the year the trade underwent a great depression, and the prices fell to a very low point, with a great accumulation of stock on hand; a remarkable upward movement then took place, and a very rapid advance in prices suddenly developed a great traffic. This, like most others, was powerfully affected by the effect of paper money upon the exchanges of the country, since as the price of bills rose it imparted a stimulus to the shipment of all available goods, and consequently the export value of the produce by no means represents the value realized abroad, since the value is in paper prices. The export value of the month of December was \$14,805,112 for domestic

produce, but in a paper depreciated 85 per cent. Hence the amount realized was \$11,000,000 only, falling below the import value, and necessitating the export of the precious metals

to make good the margin. The export trade of the port of New York, monthly, for the year, represents the greatest proportion of the national commerce for the year :

EXPORTS, PORT OF NEW YORK.

Months.	Specie.	Foreign.		Domestic.	Total.
		Free.	Dutiable.		
January .....	\$2,658,874	\$97,198	\$149,498	\$12,053,477	\$14,948,487
February .....	8,778,919	49,066	906,757	10,078,101	14,112,949
March .....	2,471,283	65,888	458,917	8,965,176	11,990,714
April .....	4,037,875	54,850	607,878	8,002,094	12,708,797
May .....	5,164,538	74,971	752,797	9,287,698	15,342,097
June .....	9,867,414	49,358	872,561	10,048,839	20,332,875
July .....	8,067,387	1,117,198	449,948	14,050,437	23,664,915
August .....	8,718,589	417,100	226,680	13,046,839	17,583,701
September .....	8,083,919	573,572	667,957	14,784,998	19,061,471
October .....	6,707,519	179,205	484,265	19,475,947	26,797,868
November .....	6,218,215	45,580	284,818	14,060,840	20,608,906
December .....	8,973,113	106,489	852,902	14,906,113	18,989,615
Total, 1863 .....	\$50,438,985	\$2,758,415	\$4,996,798	\$149,179,591	\$216,241,807
" 1861 .....	4,236,250	2,154,947	5,208,959	181,285,995	142,961,151

The banks of New York suspended at the close of 1861; but inasmuch as the institutions, in consequence, sought rather to contract than to expand their operations, no material depreciation took place until the issues of Government paper began to make their appearance in April, and became the basis of the bank paper. In the first three months the exports of produce were small. As soon, however, as the depreciation of paper began to show itself by a rise in gold, and a consequent higher price for exchange, an impetus was imparted to the export of produce, for the reason that if the market did not promise a profit abroad, the shipper by selling his bill at a higher rate for paper money realized a profit. Thus in April the price of sterling was 11 per cent., in June it had risen to 21, or 10 per cent. advance. Accordingly the exports of domestic produce in April were 8,000,000, but exceeded 10,000,000 in June; notwithstanding prices abroad were more unfavorable for shipments, with every successive rise in the bills as measured in paper money, there was more activity in shipments. Inasmuch, however, as prices became more unfavorable abroad, these shipments did not always prove profitable, notwithstanding the high price obtained for the bill, the value of which came to be regulated by that of specie. The current of the metals continued to set out in a broader stream, although they apparently bore a premium. The mode of quotation is deceptive, and the fact that specie continues to leave the country in a large volume indicates that it is still the best remittance out of the country for the banker who sells bills, even if he ships American gold. Many individuals who had remittances to make out of the country invested in produce of different descriptions; but the results were not always so favorable as if gold had been depended upon exclusively. The rise in prices of produce at the seaboard did not much improve the condition of the producer at the West, since the cost of transportation was proportionately advanced, and the cost of goods

taken in return was swollen not only by higher charges for carriage, but also by taxes and depreciation of the currency. The gradual decline in the supplies of cotton as a material for manufacture diminished the activity of an industry that usually employs a capital of 100 millions, but also that of all persons engaged in the buying and selling, and transportation of the material and goods. When the blockade took place, cutting off the supply of cotton, there was a stock in the hands of dealers and manufacturers possibly equal to six months' consumption, and the stock of goods in stores was fair. Those stocks have dwindled away under the demand for consumption, at gradually rising prices; and the stock of cotton has continued to shrink, although held by speculators generally in advance of the market for goods. Month by month, and day by day, the shelves have been thinned out, and the number of bales that form the last resort of the spinners for materials has become less. One can imagine the careful manufacturer, like a shipwrecked mariner, anxiously inspecting his pile of biscuit saved from disaster, and ruefully counting what remains after each day's inevitable consumption, and fixing the date beyond which the utmost economy will not stretch the scanty supply—the moment when the last bale will have been opened for the picker, amid preparations for the final closing of the mill. With this prospect in view, the mills have diminished their work; and the weakest, one after the other, have stopped, as the stronger have bid up for the shrinking stock of cotton 10 to 20, 30, 40, 50, 60, 70, and, finally, 90 cents, without increasing the supply, until the figures have come to represent a famine rather than a trade. These circumstances have caused strong houses to hold the goods for the use of regular customers. The remains of the once great cotton manufacture were eagerly bought up, without much regard to price; and staple goods have come to be regarded as of more value even than gold, amidst a depreciated currency.

The great apparent rise in value has doubt-

less conferred great gains upon holders as well as upon mills, the stocks of which have risen 50 to 100 per cent., as expressed in paper money, a medium certainly a little unstable, more particularly when it is borne in mind that whatever may have been the dividends of the past year, the future value depends upon food for the spindles. The machinery may be changed, and adapted to other materials; but whence are those other materials to be derived? The wool crop of the United States is always short, and foreign supplies can be had only in com-

petition with foreign buyers at great disadvantage.

The holders of goods found great advantage in the rise, but to replace most goods became, as the year advanced, a matter of more difficulty, inasmuch as while the domestic goods diminished in supply in face of the declining supply of material, the cost of importation rose in a similar ratio under the influence of higher duties, and depreciation of the currency. The imports into the port of New York were monthly as follows:

## IMPORTS, PORT OF NEW YORK.

Months.	Specie.	Free goods.	Entered for		Total.
			Consumption.	Warehouse.	
January.....	\$163,658	\$2,552,050	\$6,668,296	\$3,141,725	\$12,620,829
February.....	62,007	3,881,478	7,053,174	3,870,456	13,872,140
March.....	89,827	3,476,004	10,312,659	4,841,846	18,719,586
April.....	26,152	2,282,315	7,141,197	3,863,218	13,252,882
May.....	110,838	1,146,093	8,091,120	4,600,920	12,943,516
June.....	61,093	1,122,092	7,278,938	2,874,127	12,586,195
July.....	219,001	1,881,982	13,799,505	4,502,764	20,856,302
August.....	92,718	982,992	10,289,437	2,959,721	14,304,542
September.....	121,818	1,784,504	11,890,711	4,351,054	18,147,917
October.....	254,676	1,004,570	8,462,554	3,689,806	13,413,906
November.....	109,708	1,526,496	6,565,185	2,108,009	10,909,398
December.....	78,816	1,950,604	6,881,073	4,212,725	13,072,618
Total, 1862.....	\$1,890,282	\$22,991,625	\$104,883,954	\$44,486,481	\$173,852,313
" 1861.....	87,063,418	30,853,918	54,254,281	41,072,223	162,763,790

The importations varied from month to month, and reached the highest point in the month of July, after which the expenses of importation increased so as to weigh heavily upon the cost of goods, and make the business more hazardous. On some articles the duties were increased.

The most necessary articles, or those for which the country depends for a supply mainly upon imports, were the first to advance to such prices as would permit the importation in face of the taxes. The imports of cotton goods were much larger than for the previous year, but far less than for the corresponding period of 1860. There were about 95,000,000 yards imported against 195,000,000 in 1860. The high price of cotton in England drew large supplies from India, and this laid the groundwork of a derangement of the finances, since the larger the amount of cotton imported from a country which demands silver mostly in payment, caused a disturbing drain upon England and western Europe. The effect of this influence may be seen in the value of cotton imported into England in the first ten months of three years, as follows:

*Value of Cotton Imported into Great Britain.*

COUNTRIES.	1860.	1861.	1862.
United States.....	\$132,109,870	\$132,741,160	\$2,496,625
Brazil.....	2,337,990	1,521,655	6,370,315
Egypt.....	5,923,385	6,225,390	13,566,660
Other places.....	963,495	936,890	7,825,095
East India.....	13,487,245	31,165,565	61,161,905
Total.....	\$154,811,925	\$172,580,740	\$91,420,600

Although the aggregate imports of cotton were less, the increased purchases from India were \$30,000,000 more in 10 months of 1862

than in 1861; as a consequence, the exports of silver to that country increased \$15,000,000, and of gold \$4,000,000. A larger portion of the silver was procured from France, whence England imported \$10,500,000, and in return sent thither \$30,000,000 worth of gold. A considerable portion of this gold was required to meet American bills running on England for French goods. In ordinary years the exports of produce from the United States to Great Britain are such as to pay for United States purchases of English goods, and leave due to the United States a large balance, which is drawn against in favor of the Continent and elsewhere for balances due those countries over and above the sum of their purchases of American produce. In the past year the whole circle of trade has been interrupted. The United States have not been able to send their usual quantities of produce to France, and although less French goods have been bought, the amount has sufficed to aid the drain of coin from England to France, while the want of American cotton in England has compelled her to buy more of Indian at cash prices. This tendency has been counteracted to some extent by the increased sales of English produce to France under the new treaty. The exports from England to France and the United States for eleven months of 1862 were as follows:

COUNTRIES.	1860.	1861.	1862.
France.....	£3,968,545	£5,920,359	£7,207,769
United States..	16,623,902	7,044,592	9,862,549

As compared with 1860, France bought of England \$16,500,000 more, and the United States \$33,000,000 less. The tendency of a drain of the metals is such, however, as to in-

duce the greatest caution in England in respect to the currency. Of the exports of England to the United States in the last year the greatest increase has been in linens to the amount of \$3,500,000, and the next largest in woollens, both of which have to some extent been more in requisition by reason of the high price of cotton. The tendency to higher rates of money in England caused also lower rates for goods as well as produce, and aided in swelling the list of American imports. The tariff of July 14, 1862, increased the duties on many articles, to take effect August 1. By the new tariff woollens were charged with 18 cents per lb., and 80 per cent. *ad valorem*. Linen goods 80 per cent., and cotton goods from 1½ to 5 cents per square yard, and cotton prints 6½ cents per yard, and 10 per cent. *ad valorem*. The duty did not, however, raise the amount of revenue as much as was expected. The amount of duties for the port of New York was as follows:

*Receipts for Customs at New York, Jan. 1 to Dec. 31.*

	1861.	1862.
1st quarter.....	\$7,077,985 41	\$11,543,568 91
2d quarter.....	3,507,469 54	18,519,804 17
3d quarter.....	5,370,797 40	17,312,444 73
October.....	1,672,616 84	4,809,419 87
November.....	1,851,834 73	3,008,370 23
December.....	2,834,847 44	2,664,598 73
Total.....	\$21,714,981 86	\$52,254,116 63

The importation of goods paying duty, and the average duty paid for three years were as follows:

YEARS.	Imports, duty paid.	Customs.	Average, per cent.
1860.....	\$185,664,431	\$36,027,451	19.14
1861.....	93,971,490	21,714,981	23.00
1862.....	146,047,733	52,354,116	36.00

Thus the apparent increase of duties under the various tariffs during the war has been a little less than 17 per cent. on the value imported. Practically the duties were much higher, growing out of the fact that they are to be paid in gold, which rose in premium from June to January. The change wrought by the tariff, and by the depreciation of paper, becomes apparent in comparing the cost of imports in two months, April and December, as follows:

	April.		December.	
	Per cent.	Amount.	Per cent.	Amount.
Duty average.....	34	\$4,149,959	36	\$2,664,598
Exchange.....	11	123,966	45	2,904,893
Gold for duty...	1	41,499	32	852,669
Total cost.....	36	\$4,315,417	80	\$6,322,155
Value of imports..	..	12,496,530	..	8,013,981

The three items in April amounted to \$4,315,417, or 36 per cent. of the value of imports paying duty. In December the same items were \$6,322,155, or 80 per cent. of the dutiable imports. Under this increasing pressure the value imported declined, and for the last month in the year the amount received was not much larger than in the corresponding month for 1861.

The supply of shipping during the year was good, but the circumstances of the war were

such as to interfere with the course of freights, since the operations of the Confederate cruisers compelled an advance in the insurance for war risks upon American bottoms, and as a consequence caused a great demand for foreign vessels, of which an unusual number entered American ports during the year.

A large amount of American tonnage was taken into the service of the Federal Government, and a number of vessels, in consequence of the depredations of the enemy on the ocean, availed themselves of the present state of the English navigation act to get out British registers. The following are among the number of American vessels registered at the port of Liverpool:

Present British name.	Late American name.	Where built.	Year built.	Tonnage.
Vanguard.....	Samuel Lawrence	Medford....	1851	1,304
Ethiopian.....	Usebia N. Raye..	New Haven..	1852	188
Star of England..	E. Crichton.....	Thomaston..	1860	1,544
Eagle's Wing....	West Indian....	Baltimore...	1856	177
Prioresa.....	Prioresa.....	Scarboro'...	1856	563
Julia.....	Cavaller.....	Baltimore...	1855	240
Com.-in-Chief..	I. H. Boardman..	Portsmouth..	1855	1,718
Julie Usher.....	Annie Childs....	New York....	1861	449
D. Illton.....	R. C. Dyer.....	Belfast.....	1855	178
Adelaide.....	Adelaide.....	Philadelphia	1857	267
Rosalind.....	Louisa C. Johnson	Newbern....	1854	159
Jessie.....	Mungo Park.....	Bangor.....	1854	272
Lilla.....	Mary Wright....	Wells.....	1858	255
Sophia.....	Sophia.....	Charleston..	1852	322
Emily Caroline..	Alexander.....	Portsmouth..	1880	502
City of Melbourne	Black Warrior..	Newcastle..	1853	1,823
The Cobb.....	James Loper....	Rochester..	1887	306
Edith.....	Jas. H. Chadburn	Hoboken....	1853	349
Blanche Moore..	Blanche Moore..	Boston.....	1854	1,333
Gorilla.....	Kalamazoo.....	Portsmouth..	1840	756
Ernest.....	Champion.....	Harpwell....	1851	560
Dakotah.....	Unknown.....	Cumberland..	1851	914
Campanero.....	Campanero.....	Baltimore...	1859	271
Crossfell.....	W. V. Moses....	Unknown....	1860	1,019
Anna Helen.....	Emily St. Pierre.	Maine.....	1854	936
Wm. Graham....	Alexander.....	Baltimore...	1839	658
Nora.....	Noami.....	Newburg....	1848	569
Connecticut....	Connecticut....	Saybrook...	1840	1,198
Earl Canning...	Barede Bros....	Boston.....	1854	729
Margaret.....	Margaret.....	Philadelphia	1854	254
Blafra.....	J. Darling.....	Brookhaven	1851	195
India.....	Marathon.....	Bowdenham..	1849	594
Emily.....	Moses Wheeler..	Boston.....	1850	992
Traveller.....	Wisconmoon....	Newburg....	1841	888
Samson.....	Samson.....	Rockland...	1855	410
Rhine.....	Rhine.....	Bowdenham..	1849	608
Cambay.....	Aregona.....	Maine.....	1857	796
Saguensy.....	Adams.....	Castine....	1840	605
Sedbergh.....	John Knox.....	Bucksport...	1854	614
Mary Francis..	Isardon.....	Maine.....	1846	275
Horizon.....	Horizon.....	Ellsworth...	1854	1,768
Golden City....	Chickasaw.....	New York...	1851	1,885
Tim Whiffler..	Maduresse.....	New Bedford	1862	1,138
Young England..	Oracle.....	Thomaston..	1853	1,018
Peep o' Day....	Ella Flemming..	Waldoboro'..	1848	169
Lochnagar.....	J. Webster Clark	Waldoboro'..	1850	1,818

This change of nationality in connection with the change from the merchant service to that of the Federal Government, made a considerable difference in the tonnage returns, which for the port of New York show the following entries:

YEARS.	No. of vessels.	American tonnage.	Foreign tonnage.	Total tonnage.
1855.....	3,801	1,840,257½	220,000	1,562,257½
1856.....	3,861	1,634,596½	856,262½	2,070,859½
1857.....	3,851	1,478,579½	492,425	1,971,004½
1858.....	3,431	1,260,043	483,323½	1,693,371½
1859.....	3,905	1,302,024½	597,527½	1,899,551½
1860.....	4,348	1,487,539½	677,062	2,164,601½
1861.....	4,977	1,613,233	865,446½	2,478,704½
1862.....	5,406	1,472,939½	1,072,492	2,552,431½



The increase in foreign is very marked. In 1860 the amount of foreign tonnage was less than 30 per cent. of the whole amount entered, and in 1862 it was nearly 40 per cent. The number of arrivals has however been larger than ever, and if foreign vessels found their gain in the fears excited as to the safety of American bottoms, the supply of the latter was greatly decreased as well through the cessation of building as through the purchases of the Government. The immense outward grain freights of the past ten years have to some extent made up for the want of cotton and tobacco. The clearances of vessels have been as follows:

	No. of vessels.	Tonnage.	Seamen.
American vessels.....	2,202	1,281,722	84,548
Foreign vessels.....	2,514	1,206,180½	42,498
Total cleared in 1862....	5,016	2,487,852½	77,086
“ in the year 1861....	4,808	2,888,766½	74,925
“ in the year 1860....	3,812	1,970,997½	68,750

The number of foreign vessels exceeded that of the American, as also did the number of seamen, although the aggregate tonnage was not so large. The American vessels are generally of a larger size than the foreign. Many of the latter, which run short voyages, in effect coasting voyages to and from the provinces, are small, and making a number of trips in the year, swell the tonnage to a high figure. The same remarks apply to the entries which have been as follows, distinguishing foreign vessels and seamen:

	No. of vessels.	Tonnage.	Seamen.
American vessels.....	2,693	1,472,989½	89,762
Foreign vessels.....	2,718	1,079,492	42,056
Total entered in 1862....	5,406	2,552,481½	81,817
“ in the year 1861....	4,977	2,483,704½	78,264
“ in the year 1860....	4,346	2,164,801½	72,510

The arrivals and departures of the ocean steamers have been very active during the year. The following table shows the number of passengers carried to and brought from Europe by the various lines during the past year:

LINES.	East-	West-	Total.
	ward.	ward.	
Liverpool, New York, and Philadelphia steamers.....	10,881	18,454	29,335
Cunard New York line.....	2,858	2,786	5,639
Cunard Boston line.....	2,260	1,946	4,206
Bremen line.....	2,947	4,298	6,645
Hamburgh line.....	8,689	7,411	11,098
Liverpool, Quebec, and Portland.....	4,611	10,014	14,625
Anchor line, Glasgow, Quebec, &c.....	1,051	8,746	4,797
Great Eastern.....	796	1,357	2,153
Irregular steamers.....	88	895	488
Total in 1862.....	28,519	50,407	78,926
“ in 1861.....	28,956	40,851	69,807
Increase in 1862 over 1861.....			9,119

The number of persons arrived from abroad has in the past ten years greatly exceeded the number of those who departed. None of the

lines of steamers lost any vessel during the year. The oldest line, the Cunard, ran with their accustomed regularity, and have placed two new steamers on the route: the Scotia, a side wheel, and the China, a screw. This, with the Australasian, makes two screw steamers, and there are indications that the screws may supplant the side wheels for mail and passenger service. The Scotia, however, made the shortest passages of the year, both ways, viz.: western passage, June 21 to July 1, 9 days 22 hours, and eastern passage, August 27 to September 5, 9 days 7 hours.

The City of Washington of the Liverpool, New York, and Philadelphia line made the passage to Liverpool in 9 days and 22 hours. This line has 8 steamers, and the Cunard 6, but it carries by far the greatest number of passengers, having nearly one third of the whole.

The Fulton and Arago, formerly running between New York and Havre, have been employed by the Federal Government during the past year.

A few transient steamers have made one or more voyages within the year, among which were the Stella, Congress, Melita, &c.

The Great Eastern made four passages during the year. The longest, west, 11 days 8 hours, and the shortest, east, 9 days 20½ hours. She did not thus sustain her reputation founded on her great size, of being able to make the shortest passages.

The statement of the coasting trade is made up with more difficulty since, in order to facilitate intercommunication with domestic ports, all vessels engaged in coastwise commerce may arrive and depart without official record, unless they have foreign goods or distilled spirits on board. Few of the vessels arriving from domestic ports come within this exception, and the official record of coastwise arrivals includes but a fraction of the actual trade. The vessels which clear from New York for other domestic ports oftener carry the description of goods specified, and thus the clearances on this record are far greater than the entries. During the last two years the coastwise commerce has, of course, been greatly interrupted, and the record is very small. The official returns, however, show the following results:

YEARS.	Entered coastwise.		Cleared coastwise.	
	No. of vessels.	Tons.	No. of vessels.	Tons.
1849.....	1,855	424,976	3,994	895,589
1850.....	1,928	489,395	4,719	1,020,070
1851.....	1,768	455,542	4,808	1,214,942
1852.....	1,766	497,840	4,680	1,178,762
1853.....	1,733	507,581	4,789	1,310,697
1854.....	1,880	548,452	4,779	1,499,968
1855.....	1,966	614,045	4,568	1,378,888
1856.....	1,669	589,461	4,696	1,482,310
1857.....	1,569	508,679	4,182	1,425,810
1858.....	1,559	499,138	4,381	1,640,478
1859.....	1,838	572,232	4,698	1,726,998
1860.....	1,571	529,015	4,908	1,902,508
1861.....	1,240	398,024	2,905	592,919
1862.....	1,382	477,010	2,302	619,807

**CONFEDERATE STATES.** The States united in the Southern Confederacy are Alabama, Arkansas, Florida, Georgia, Louisiana, Mississippi, North Carolina, South Carolina, Tennessee, Texas, and Virginia. Their population and resources, as presented by the returns of the census of 1860 are important considerations in the present struggle to maintain a separation from the other States. Their population was as follows:

STATE.	White.	Free Colored.	Slave.
Alabama.....	526,481	2,690	485,080
Arkansas.....	324,191	144	111,115
Florida.....	77,748	992	61,745
Georgia.....	591,588	8,500	462,199
Louisiana.....	357,639	18,647	381,796
Mississippi.....	358,901	778	436,681
North Carolina.....	681,100	30,463	381,059
South Carolina.....	291,988	9,914	402,406
Tennessee.....	826,782	7,900	275,719
Texas.....	431,294	355	182,566
Virginia.....	1,047,411	58,052	490,965
<b>Total.....</b>	<b>5,449,468</b>	<b>132,770</b>	<b>3,521,110</b>

The ratio of increase during the ten years closing with 1860, was as follows:

STATE.	White.	Free Col'd.	Slave.
Alabama.....	23.48	18.76	37.18
Arkansas.....	99.88	81.25	185.91
Florida.....	64.70	.....	57.07
Georgia.....	18.43	19.41	21.10
Louisiana.....	39.95	6.73	35.50
Mississippi.....	19.86	16.88	40.90
North Carolina.....	14.19	10.92	14.73
South Carolina.....	6.18	10.65	4.58
Tennessee.....	9.24	18.67	15.14
Texas.....	173.51	10.58	213.89
Virginia.....	17.06	6.58	3.88

In the cotton-growing States of Alabama, Mississippi, Arkansas, and Texas, the increase of the slave population is more rapid than that of the white population. In Louisiana, which raises sugar and cotton, the increase is nearly in the same ratio as that of the white population. In Virginia and South Carolina the increase of the white population is in the most rapid ratio. In these two States such physical causes were in operation as might ultimately have released the slaves.

The white population of the Confederate States, according to sex was, in 1860, as follows:

STATE.	Male.	Female.
Alabama.....	270,190	256,081
Arkansas.....	171,477	152,666
Florida.....	41,128	36,619
Georgia.....	301,066	290,484
Louisiana.....	189,648	167,808
Mississippi.....	186,273	167,626
North Carolina.....	313,670	316,272
South Carolina.....	146,160	145,140
Tennessee.....	422,779	408,943
Texas.....	228,585	192,306
Virginia.....	528,842	518,457
<b>Total.....</b>	<b>2,799,818</b>	<b>2,647,402</b>

About 250,000 should be deducted for the population of western Virginia.

The following is a statement of the amount and value of certain articles produced in the Confederate States during the year ending June 1, 1860, and in all the States during the same period:

**PIG IRON.**

STATE.	Tons of ore mined.	Tons of pig iron.	Value.
Tennessee.....	53,220	18,417	\$457,000
Virginia.....	23,217	9,096	251,178
<b>Total.....</b>	<b>76,437</b>	<b>27,513</b>	<b>\$708,178</b>
In the United States.....	2,514,282	884,474	\$19,487,790

**BAR AND OTHER ROLLED IRON.**

STATE.	Tons.	Value.
North Carolina.....	1,007	\$92,948
South Carolina.....	275	24,750
Tennessee.....	5,024	438,248
Virginia.....	17,370	1,147,425
<b>Total.....</b>	<b>24,176</b>	<b>\$1,748,871</b>
United States.....	406,298	22,248,796

**IRON FOUNDRY.**

STATE.	Value.
Alabama.....	\$142,480
Arkansas.....	52,000
Florida.....	63,000
Georgia.....	79,000
Louisiana.....	525,800
Mississippi.....	147,550
North Carolina.....	56,650
South Carolina.....	5,000
Tennessee.....	552,050
Texas.....	70,877
Virginia.....	809,955
<b>Total.....</b>	<b>\$2,504,363</b>

Aggregate in the United States for the same period \$28,546,656.

STATE.	Copper.		Lead, value.
	Tons.	Value.	
North Carolina.....	2,000	\$105,000	.....
Tennessee.....	2,379	404,000	.....
Virginia.....	1,500	81,850	\$61,000
<b>Total.....</b>	<b>5,879</b>	<b>\$540,850</b>	<b>\$61,000</b>
United States.....	14,482	8,316,516	977,281

STATE.	Horses.	Mules.	Swine.
Alabama.....	127,205	108,701	1,786,959
Arkansas.....	101,249	44,158	155,379
Florida.....	18,424	10,909	274,814
Georgia.....	180,771	101,069	2,068,116
Louisiana.....	79,068	92,259	642,555
Mississippi.....	117,134	112,488	1,584,097
North Carolina.....	150,661	51,888	1,883,214
South Carolina.....	81,125	56,456	965,779
Tennessee.....	239,543	119,221	2,343,943
Texas.....	820,621	63,000	1,363,378
Virginia.....	287,522	41,014	1,589,519
<b>Total.....</b>	<b>1,696,828</b>	<b>790,663</b>	<b>15,580,538</b>
United States.....	6,089,942	1,116,583	82,497,811

STATE.	Working oxen.	Other cattle.*	Sheep.
Alabama.....	92,495	452,643	869,061
Arkansas.....	70,944	313,355	202,674
Florida.....	7,737	284,786	29,953
Georgia.....	74,437	631,707	512,618
Louisiana.....	61,008	329,858	180,555
Mississippi.....	104,184	415,559	387,754
North Carolina.....	48,511	416,676	548,749
South Carolina.....	22,629	320,209	233,509
Tennessee.....	104,495	408,574	773,317
Texas.....	172,248	2,782,267	788,618
Virginia.....	97,862	615,696	1,042,946
<b>Total.....</b>	<b>856,645</b>	<b>6,227,280</b>	<b>5,013,059</b>
United States.....	2,188,154	14,569,925	22,481,428

\* Milch cows are not included.

STATES.	Wheat, bushels.	Rye, bushels.	Corn, bushels.
Alabama.....	1,222,487	73,943	82,761,194
Arkansas.....	955,298	77,569	17,758,665
Florida.....	2,808	21,314	2,824,588
Georgia.....	2,544,918	115,532	30,776,293
Louisiana.....	29,283	12,789	16,205,856
Mississippi.....	579,452	41,260	29,563,735
North Carolina..	4,743,706	436,856	30,078,564
South Carolina..	1,285,631	89,091	15,065,606
Tennessee.....	5,409,863	265,344	50,748,266
Texas.....	1,464,273	95,012	16,521,593
Virginia.....	13,129,180	944,024	38,360,704
Total.....	31,366,894	2,173,038	290,665,014
United States....	170,176,027	20,965,066	827,694,528

STATES.	Rice, pounds.	Peas and beans, bushels.
Alabama.....	499,559	1,488,609
Arkansas.....	315	459,412
Florida.....	223,209	864,783
Georgia.....	52,507,652	1,765,214
Louisiana.....	6,453,017	450,410
Mississippi.....	657,223	1,938,658
North Carolina..	7,593,976	1,932,204
South Carolina..	119,100,623	1,728,074
Tennessee.....	20,516	650,913
Texas.....	25,670	859,560
Virginia.....	3,225	515,004
Total.....	187,101,860	11,535,096
United States....	187,180,173	15,099,746

STATES.	Irish potatoes, bushels.	Butter, pounds.
Alabama.....	897,556	6,125,708
Arkansas.....	418,000	4,062,481
Florida.....	18,549	404,470
Georgia.....	314,563	5,489,765
Louisiana.....	887,725	1,440,943
Mississippi.....	401,804	5,111,188
North Carolina..	890,565	4,735,495
South Carolina..	924,785	3,177,384
Tennessee.....	1,174,647	10,000,923
Texas.....	168,937	5,943,611
Virginia.....	2,292,118	18,461,719
Total.....	6,582,188	59,909,127
United States....	110,023,189	450,672,652

STATES.	Salt.	
	Bushels.	Value.
Texas.....	120,000	\$29,800
Virginia.....	2,066,513*	478,684
Total.....	2,176,513	\$508,484
United States....	12,190,958	2,285,302

The amount of capital invested in the manufacture of cotton goods in the Confederate States during the year ending June 1, 1860, was \$9,303,921; total in the United States, \$99,551,465.

The amount of capital invested in the manufacture of woollen goods in the Confederate States during the same period was \$1,317,980; total in the United States, \$35,520,527.

The annual product of the manufacture of boots and shoes in the four States of Virginia, Louisiana, Tennessee, and Georgia, during the same period, was \$2,729,327; total in the United States, \$89,549,900.

The value of the product of leather in the Confederate States, during the same period,

\* This includes the salt mines of western Virginia held by United States forces.

was \$4,074,406; total in the United States, \$68,090,751.

In the production of the staples for food above mentioned, the proportion of the Confederate States is well maintained. In manufactures they are less advanced. These States possess also their peculiar products of sugar, cotton, and tobacco, which are an inexhaustible source of wealth, and enable them to be consumers of the productions of all the other States.

STATES.	Tobacco, lbs.	Ginned cotton, bales.	Sugar, hhds.
Alabama.....	221,264	997,978	106
Arkansas.....	999,757	367,485	.....
Florida.....	753,015	63,822	1,761
Georgia.....	919,316	701,840	1,167
Louisiana.....	173,737	722,218	297,816
Mississippi.....	127,796	1,195,069	244
North Carolina..	25,522,972	.....	83
South Carolina..	104,412	853,413	193
Tennessee.....	88,981,377	227,450	.....
Texas.....	93,016	406,100	500
Virginia.....	122,967,757	12,727	.....
Total.....	191,885,279	5,047,222	301,222

A provisional government for the Confederate States, to continue for one year, was adopted by the Provisional Congress at its first session in February, 1861. This was simply a temporary form for the regulation of the actions of those persons who should exercise the combined authority of these States during the first year of their union as Confederate States. It consisted of the Constitution of the United States with such modifications as were necessary to adapt it to the peculiar circumstances then existing. The members of this Provisional Congress were appointed by the conventions in the respective States, who were elected by the people while they were a part of the United States. The Provisional Congress elected the Executive and clothed him with powers to organize and execute the duties of a Government, in opposition to the United States. During the year a permanent form of government was proposed and submitted to the approval of the Conventions or Legislatures of the respective States. It was approved unanimously. The time for it to go into operation by superseding the Provisional Government, was the 18th of February, 1862. Thus far nothing had been submitted to the action of the people. When last at the polls they were citizens of the United States. Now they were declared to be citizens of another country, acting under another Government, and performing duties prescribed by another supreme law. This change had been produced, not by the natural operation of forms already adopted by themselves, but in consequence of their destruction. It was provided that in November the officers under the Permanent Government should be elected. The name of one candidate for the Presidency only was submitted to the people. Like the election in France, the people were perfectly free to vote for electors who would choose him, or not vote at all. He was unanimously elected. At the same

time, members of Congress under the Permanent Constitution were elected. The only point involved before the people in these elections, was whether this or that man should be chosen to Congress. Every question relative to the previous condition of the people, as citizens of the United States, and the change which had been made, had passed beyond the consideration of the voters. In fact, no such question was ever submitted to their action. Such were the forms under which the Government of the Confederate States came into operation, and at the close of 1861, when nearly a year had passed away, it was weak and trembling under the uncertainty of its future existence. A frenzy, like that which suddenly created it, might as suddenly extinguish it. It had no hold upon the hearts of the people, arising from convictions long entertained of its necessity. There had never been any peculiar interests in existence, which required its organization for their special protection; and there never would be, unless the Government of the United States by future hostile action should assail the interests of the people, and demonstrate its necessity. In that case only, and under such adverse circumstances, could it be expected to become so rooted in the hearts of the people as to receive their unanimous and unflinching support. The existence of the Confederate Government at this period was entirely in the hands of the Federal Government; and the statesmanship with which the latter was wielded, was destined either to extinguish the former or to nurse it into vigorous life. The causes of this weakness were developed as early as the beginning of the year 1862, and were then in operation. The movement to establish the Confederate States was urged upon the people as necessary to save themselves from degradation and to preserve their property in slaves against the hostile action of the Federal Government, as it would be administered by the newly elected President, Abraham Lincoln. These arguments were addressed to two classes of citizens—those who were wealthy and the owners of slaves, or whose interests were interwoven with this class, and those who were comparatively poor, and whose labor suffered under the competition of that of the slaves. They were insufficient to convince the majority of either class to espouse the movement, and it would have been an utter failure had there been no stimulating causes created outside of the limits of the Confederate States. Even with the aid of the latter it was successful only by a resort to all those arts which the skilful can devise to bias the public mind. In the choice of delegates to the State Conventions, a large minority of the voters did not appear at the polls. Thus the Confederate Government came into existence by the tolerance of a large mass of its citizens. This mass was the chief element which Federal statesmanship should have used for its destruction. The new Administration of the United States was not entirely insensible of the advan-

tages within its grasp. Its first movements aimed to secure the confidence of this mass of the citizens in the Confederate States. President Lincoln denied that he had any designs hostile to the institutions of those States, and declared that he would not be foremost to commence hostilities, but would continue the benefits of the Government to those States as far as practicable in their existing posture. He said:

Apprehension seems to exist among the people of the Southern States that, by the accession of a Republican Administration, their property, their peace, and personal security are to be endangered. There has never been any reasonable cause for such apprehension. Indeed, the most ample evidence to the contrary has all the while existed, and been open to their inspection. It is found in nearly all the published speeches of him who now addresses you. I do but quote from one of these speeches when I declare that "I have no purpose, directly or indirectly, to interfere with the institution of slavery in the States where it exists." I believe I have no lawful right to do so, and I have no inclination to do so. And, more than this, they placed in the platform, for my acceptance, and as a law to themselves and to me, the clear and emphatic resolution which I now read:

*Resolved*, That the maintenance inviolate of the rights of the States, and especially the right of each State to order and control its own domestic institutions according to its own judgment exclusively, is essential to that balance of power on which the perfection and endurance of our political fabric depend; and we denounce the lawless invasion by armed force of the soil of any State or Territory, no matter under what pretext, as among the gravest of crimes.

I now reiterate these sentiments; and in doing so I only press upon the public attention the most conclusive evidence of which the case is susceptible, that the property, peace, and security of no section are to be in any wise endangered by the now incoming Administration. I add too, that all the protection which, consistently with the Constitution and the laws, can be given, will be cheerfully given to all the States when lawfully demanded, for whatever cause, as cheerfully to one section as to another.

The effect of these and similar declarations was to stop the progress of secession, and the great States of Virginia, North Carolina, Tennessee, Arkansas, and Missouri quietly continued as members of the United States. Still the declarations of a President are of little value, any further than they express the views of the political party he represents. The Confederate Government, as yet powerless at home, protested that peace was its only wish. As it gathered strength by completing its independent organization, it soon became apparent that without hostilities with the Federal Government it must soon perish through deficient vitality. The brilliant and dazzling dreams of the future republic still failed to warm the hearts of a portion of the Southern people in its favor; the most bitter denunciations of the tyranny of the North were equally unable to kindle the anger of those citizens, and rouse in them a stern determination to sustain the new union with a patriot's firmness. War alone would relieve the Confederate Government of these embarrassments. It would cut off all communication between the North and the South. It would shut out the Federal Government, and destroy all its means of access to the

minds of the Southern people. It would become an inexhaustible fountain to furnish bitterness between the North and the South. It would separate the neutral mass of Southern citizens from the Federal Government, and render them powerless against the new Government over them. The gauntlet of hostilities was thrown down by the Confederate Government, and as quickly caught up by the Federal Government. Instantly four of the States above mentioned, Virginia, North Carolina, Tennessee, and Arkansas, were precipitated out of the Federal Union, and joined the Confederacy. The Confederate Government then appealed to its citizens to bear witness to the truth of the original charges of hostile designs against them on the part of the Federal Administration—asserting that the convictions of the reality of these hostile designs had led to its own organization, and demanded their undivided and hearty support. This *coup d'etat* on the part of the Confederate Government was immediately followed by a system of rigid and arbitrary measures in the Confederate States, to repress and extinguish every indication of sympathy for the Federal Union. The most bitter denunciations were hurled against the Northern people, and contempt cast upon them as designing to accomplish a social and political equality between the mass of the white people and the negroes.

Notwithstanding all these efforts, the Confederate Government at the beginning of 1862 was still weak and insecure of the confidence and honest support of a portion of its citizens. The action of the Federal Government had been such as to cause to some extent this withholding of confidence. When it accepted hostilities with the South and became aware of the advantages it thereby lost for reaching the minds of the Southern people, it proclaimed in the most solemn manner, by a nearly unanimous vote of Congress, "that in this national emergency, Congress, banishing all feeling of mere passion or resentment, will recollect only its duty to the whole country; that this war is not prosecuted on our part in any spirit of oppression, nor for any purpose of conquest or subjugation, nor for the purpose of overthrowing or interfering with the rights or established institutions of those States, but to defend and maintain the supremacy of the Constitution and all laws made in pursuance thereof, and to preserve the Union, with all the dignity, equality, and rights of the several States, unimpaired; that as soon as these objects are accomplished the war ought to cease." Its public action had thus far been generally consistent with this declaration, and the effect of it was to preserve the adhesion of the slaveholding States of Delaware, Maryland, Kentucky, and a majority in Missouri to the Federal Union. At the same time it produced an unfavorable effect upon secession.

Other causes had operated against the success of the Confederate States which may be

briefly mentioned. The expectation that the manufacturing necessities of England and France would force them to a speedy recognition of the Confederacy and to an interference with the Federal blockade, had proved entirely groundless. The supply of cotton was as large in Liverpool at the beginning of 1862 as at the beginning of 1861, although the blockade of the Southern ports had then existed more than six months. No necessity for an interference existed, and no disposition voluntarily to interfere had been manifested anywhere. At the courts of Europe the Confederate ambassadors were not noticed in their official character. The Governments of those nations, grown hoary during an existence of a thousand years, stood far aloof from the youthful aspirant. The Confederate people said: "They who have managed our public affairs have not, with any Government, any class, or any description of people, succeeded in securing one reliable friend; and so insupportable has the position of Commissioner to Europe become, that Mr. Yancey is impatient for his recall." The news of the capture of Messrs. Mason and Slidell brought gold down at Richmond from thirty-five to fifteen per cent. premium. Confidence in the Confederate Government increased as the prospect of a war between the United States and England appeared. The release of these men was a bitter disappointment, and under the depression gold mounted rapidly again to an exorbitant premium. The ardent adherents of the Confederate Government, those most deeply involved in the cause, exclaimed against the North in their anger. "Wonderful people! wonderful press! wonderful Congress! wonderful Secretaries! wonderful Yankeedom! Certainly the world never saw your like before. Even Egypt, 'the basest of kingdoms,' is respectable when compared to you." The hope that the commercial enterprise of England would spring at once to the enjoyment of the high prices the blockade established, by sending forward cargoes of arms, munitions, medicines, and other stores most needed, was found likewise to be a delusion. The Governors of several of the States were obliged to issue appeals to the citizens to contribute their shot guns and fowling pieces to arm the Confederate troops. In Alabama an appropriation was made by the Legislature to manufacture pikes with which to arm the soldiers. It consisted of a keen two-edged steel head, like a large bowie-knife blade, nearly a foot and a half in length, with a sickle-like hook, very sharp, bending back from near the socket. This was intended for cutting the bridles of cavalymen, or pulling them off their horses, or catching hold of an enemy when running away. The head was mounted on a shaft of tough wood about eight feet long. In the southwest Gen. Beauregard issued a proclamation, in which he appealed to the people to contribute brass and other metal to the Government to be moulded into cannon. Under this call the bells of churches and plantations

in vast numbers were given, and even brass andirons and the weights of clocks and windows were not withheld by some. Appeals were made to the people to rouse them to new exertions, which proclaimed the desperateness of their situation: "A thousand proofs exist that the Southern people are not sufficiently alive to the necessity of exertion in the struggle in which they are involved. Our very victories have brought injury upon the cause, by teaching us to despise the public adversary. The immense magnitude of his preparations for our subjugation has excited no apprehension and had little effect in rousing us to exertion." Again it was cautiously said: "It seems to be the popular impression, we see it in men's faces, when we do not hear it in their words, that the military affairs of the Confederacy are not very cheering." The Governor of Virginia issued a proclamation to the people, saying: "The exigencies of the times are not duly appreciated by many of our people. The dangers which environ us are too lightly estimated. We must see and feel their imminence before we can be aroused to that action which is necessary to save us from alarming ills, and to avert evils which threaten our existence, our peace, and our organization as a Government." Complaints and charges of imbecility were now brought against the Confederate Government in terms like the following: "There has been a sad absence of enterprise, genius, and energy in the conduct of public affairs, such as gives nerve to the soldier's arm and kindles a flame in his heart." "We ask why the year has passed and we further than ever from recognition at home or abroad. We ask why we are fifty-fold worse off than when the war commenced?" "The want of faith in the Government is more and more clearly manifested every day." Apprehensions of the power of the United States oppressed the citizens of the Confederacy; they said: "A lull, a pause, a suspense exists, preceded by minor events which cause a feeling of apprehension more than of confidence in the future. We know that the enemy are in great power and meditate mischief, and we feel that ere long their blows, the heaviest of the war, must fall." "The dark hour of our trial will come whenever McClellan has succeeded in converting his Yankees into the involuntary machines known to the military science as regiments, brigades, and divisions. This is the end that he proposes to himself. This is the secret of his long delay. This is the work of his hands and his head at this moment." The flattering hope was also indulged that the finances of the United States would soon be exhausted, that the spirit of the people would soon be discouraged. These circumstances serve to show the weakness of the Government in the confidence of the people. On the other hand, public bodies, as if to produce an inspiring and reviving effect, passed resolutions expressive of the greatest determination.

In the Legislature of Tennessee resolutions

were offered "that all propositions of the Congress of the (so called) United States to reconstruct a union which they have prostituted to the base purposes of annihilating the liberties, trampling upon the rights, destroying the lives, and plundering the people of the Confederate States, is but another form under which our enemies would subjugate the South and reduce us to the despotism of their degrading doctrines, &c., and that any such proposition should be met promptly and unhesitatingly with our indignant rejection."

The Legislature of Georgia passed resolutions at this time declaring that the separation "is, and ought to be final, and irrevocable," and that no proposition having for its object reconstruction would be entertained; and that Georgia pledged herself "to stand by her sister States of the Confederacy throughout the struggle."

Governor Letcher of Virginia, in his Message to the Legislature, said: "We have therefore separated from them, and now let it be understood that the separation 'is, and ought to be final and irrevocable,'—that Virginia will under no circumstances entertain any proposition from any quarter, which may have for its object a restoration or reconstruction of the late Union on any terms and conditions whatever." It should be remembered that the Legislatures which received or passed these resolutions, and the governor who expressed similar views—were all elected while their constituents were citizens of the United States, and by their acts the secession of their respective States was accomplished.

On the 26th of February, a resolution was offered in the Confederate Congress, then in session at Richmond, by a Senator from Kentucky, and referred, which declared "that the people of the Confederate States will to the last extremity maintain and defend their right to self-government, and the government established by them, and to this end will pledge their last man and their last dollar for the vigorous prosecution of the war, until their independence is acknowledged; and also that they will submit to any sacrifice and endure any trial, however severe, and firmly relying on the justice of their cause, and humbly trusting in the providence of God, will maintain their position before the world and high heaven while they have a voice to raise or an arm to defend."

On the next day it was observed in Richmond that the walls in different parts of the city were "scrawled over with inflammatory and treasonable mottoes." The circumstances were thus described: "They attracted but little attention at first, as the chalked letters were supposed to be the amusement of some idlers. On further examination, however, it was found that these mottoes were displayed all over the city with a system and consistency that showed that there were purpose and organization in this appeal to the multitude. The follow-

ing are some of the mottoes; they were written in large and singularly well-formed letters, at different points in the city, extending even to the suburbs on Church Hill, and show a literary merit that could hardly be ascribed to blackguards, and is seldom found in mere rowdy scrawls on the street corners:

"Nationals, to the rescue!"  
 "Nationals, arise and gird on your strength!"  
 "Unionists, it is time to assert your rights!"  
 "Too many stars on the flag!"  
 "The Scorpion of Secession—it has stung itself!"  
 "The South—the land of the white man!"  
 "The Northern advance—it is the tread of the freeman," &c.

It was declared to be the work of traitors, and demands were made for the appointment of a vigilance committee as required "by the most conservative and precious interests of society." At the same date one of the daily prints of the city, made the following statement: "Our Tennessee exchanges give us gloomy prospects for the future in that part of the Confederacy. Several leading journals intimate plainly that there is really a threatening state of idolatrous love of many of these people for the old Union."

A letter from the interior of Tennessee, published at this time in the city of Memphis, stated thus: "The condition of the interior counties is not improved by the lapse of time. The people apprehend an immediate advance of the Northmen, and traitors to the South evince their joy in every village and neighborhood. The Unionists are making demonstrations in many of the northern counties, and even at Memphis there were exhibitions of joy at the arrival of the news from Beech Grove.

"In the remote counties many have been shot at night in their own houses, who adhered to the fortunes of the South."

On the part of those who had been the principal actors in accomplishing the secession of the Confederate States, the same determined purpose was still manifested. This is illustrated by the following address to the people of Georgia by their representatives in the Provisional Congress, which was issued on the 31st of January:

**FELLOW CITIZENS:** In a few days the Provisional Government of the Confederate States will live only in history. With it we shall deliver up the trust we have endeavored to use for your benefit, to those more directly selected by yourselves. The public record of our acts is familiar to you, and requires no further explanation at our hands. Of those matters which policy has required to be secret, it would be improper now to speak. This address, therefore, will have no personal reference. We are well assured that there exists no necessity for us to arouse your patriotism, nor to inspire your confidence. We rejoice with you in the unanimity of our State, in its resolution and its hopes. And we are proud with you that Georgia has been "illustrated," and we doubt not will be illustrated again by her sons in our holy struggle. The first campaign is over; each party rests in place, while the winter's snow declares an armistice from on high. The results in the field are familiar to you, and we will not

recount them. To some important facts we call your attention:

*First.*—The moderation of our own Government, and the fanatical madness of our enemies, have dispersed all differences of opinion among our people, and united them forever in the war of independence. In a few border States a waning opposition is giving way before the stern logic of daily developing facts. The world's history does not give a parallel instance of a revolution based upon such unanimity among the people.

*Second.*—Our enemy has exhibited an energy, a perseverance, and an amount of resources which we had hardly expected, and a disregard of constitution and laws which we can hardly credit. The result of both, however, is that power, which is the characteristic element of despotism, and renders it as formidable to its enemies as it is destructive to its subjects.

*Third.*—An immense army has been organized for our destruction, which is being disciplined to the unthinking stolidity of regulars. With the exclusive possession of the seas, our enemy is enabled to throw upon the shores of every State the nucleus of an army. And the threat is made, and doubtless the attempt will follow in early spring to crush us with a giant's grasp by a simultaneous movement along our entire borders.

*Fourth.*—With whatever alacrity our people may rush to arms, and with whatever energy our Government may use its resources, we cannot expect to cope with our enemy either in numbers, equipments or munitions of war. To provide against these odds we must look to desperate courage, unflinching daring, and universal self-sacrifice.

*Fifth.*—The prospect of foreign intervention is at least a remote one, and should not be relied on. If it comes, let it be only auxiliary to our own preparations for freedom. To our God and ourselves alone we should look.

These are stern facts, perhaps some of them are unpalatable. But we are deceived in you if you would have us to conceal them in order to deceive you. The only question for us and for you is, as a nation and individually, What have we to do? We answer:

*First.*—As a nation we should be united, forbearing to one another, frowning upon all factious opposition and censorious criticisms, and giving a trustful and generous confidence to those selected as our leaders in the camp and the council chamber.

*Second.*—We should exert every nerve and strain every muscle of the body politic to maintain our financial and military healthfulness, and by rapid aggressive action, make our enemies feel, at their own firesides, the horrors of a war brought on by themselves.

The most important matter for you, however, is your individual duty. What can you do?

The foot of the oppressor is on the soil of Georgia. He comes with lust in his eye, poverty in his purse, and hell in his heart. He comes a robber and a murderer. How shall you meet him? With the sword, at the threshold! With death for him or for yourself! But more than this—let every woman have a torch, every child a firebrand—let the loved homes of our youth be made ashes, and the fields of our heritage be made desolate. Let blackness and ruin mark your departing steps, if depart you must, and let a desert more terrible than Sabara welcome the Vandals. Let every city be levelled by the flame, and every village be lost in ashes. Let your faithful slaves share your fortune and your crust. Trust wife and children to the sure refuge and protection of God—preferring even for these loved ones the charnel house as a home than loathsome vassalage to a nation already sunk below the contempt of the civilized world. This may be your terrible choice, and determine at once and without dissent, as honor and patriotism and duty to God require.

**FELLOW CITIZENS:** Lull not yourselves into a fatal security. But prepare for every contingency. This

is our only hope for a sure and honorable peace. If our enemy was to-day convinced that the feast herein indicated would welcome him in every quarter of this confederacy, we know his base character well enough to feel assured he would never come. Let, then, the smoke of your homes, fired by women's hands, tell the approaching foe that over sword and bayonet they will rush only to fire and ruin.

We have faith in God, and faith in you. He is blind to every indication of Providence who has not seen an Almighty hand controlling the events of the past year. The wind, the wave, the cloud, the mist, the sunshine, and the storm have all ministered to our necessities, and frequently succored us in our distress. We deem it unnecessary to recount the numerous instances which have called forth our gratitude. We would join you in thanksgiving and praise. "If God be for us, who can be against us?"

Nor would we condemn your confident look to our armies, when they can meet with a foe not too greatly their superior in numbers. The year past tells a story of heroism and success, of which our nation will never be ashamed. These considerations, however, should only stimulate us to greater deeds and nobler efforts. An occasional reverse we must expect—such as has depressed us within the last few days. This is only temporary.

We have no fears of the result—the final issue. You and we may have to sacrifice our lives and fortunes in the holy cause; but our honor will be saved untarnished, and our children's children will rise to call us "blessed."

HOWELL COBB,  
E. TOOMBS,  
M. J. CRAWFORD,  
THOMAS R. R. COBB.

Such was the public sentiment in the Confederate States at the beginning of 1862. In a military aspect their position appeared extremely favorable. Their extreme line of defence had been unassailed, and was believed to be impregnable. The intrenchments at Manassas, the fortifications on the Cumberland, and at Bowling Green and Columbus were regarded as too strong to be taken by any Federal force. In the contests of the previous year, the Confederate soldiers claimed that victory had constantly fallen to their cause, and in personal prowess they had no fears of their foe. There were, however, other causes more hidden that threw a cloud over these cheering prospects. The United States were known to be preparing to exert their utmost strength, and it could be clearly seen that a fearful struggle was at hand. Arms and munitions of war could not be had in sufficient abundance. The commerce of the Confederate States was annihilated, and a most stringent blockade endangered every venture. The luxuries of life were consumed, and even the necessary articles were becoming scarce. The credit of the Government was declining, and its obligations vastly depreciated. At such a time the Federal troops began their march of invasion, and the strong Confederate positions in Kentucky were captured or evacuated. (See ARMY OPERATIONS.)

Amid such circumstances the Provisional Government ceased to exist, and the Permanent Government was inaugurated. This ceremony took place at Richmond, the seat of Government, on the 22d day of February. At half past 7 o'clock on the morning of that day the two Houses of

Congress assembled, having organized on the 18th, and appointed committees to wait upon the President and Vice-President elect, by whom they were escorted to the Hall of the House of Delegates of Virginia. At half past twelve the assemblage moved by the eastern door of the capitol in grand procession, formed similar to those in Washington on such occasions, to the statue of Washington on the public square. At the statue of Washington the President elect, the Vice-President elect, the President of the Senate, the Speaker of the House of Representatives, the officiating clergyman, Confederate Judges, Governors of States, Judges of the Supreme Courts of States, the Chief Marshal and his aids, and six of the Committee of Arrangements, took positions on the platform. Prayer was then offered by Bishop Johns. The delivery of the inaugural address by Jefferson Davis then followed (see PUBLIC DOCUMENTS), and the oath of office was administered by Judge J. D. Halyburton.

In this address President Davis asserted that the Confederate Government was established to maintain their "ancient institutions;" "to preserve in spirit as well as in form a system of government we believed to be peculiarly fitted for our condition." For proofs of the sincerity of this purpose he says: "We may point to the Constitution of the Confederacy and the laws enacted under it, as well as to the fact that through all the necessities of an unequal struggle there has been no act on our part to impair personal liberty, or the freedom of speech, of thought, or of the press." He then points to the acts taking place in the United States under the Federal Administration as flagrant violations of private rights, and asserts that if any Union feeling has thus far existed it must now expire as hopeless. "Whatever of hope some may have entertained that a returning sense of justice would remove the danger with which our rights were threatened, and render it possible to preserve the Union and the Constitution, must have been dispelled by the malignity and barbarity of the Northern States in the prosecution of the existing war. The confidence of the most hopeful among us must have been destroyed by the disregard they have recently exhibited for all the time-honored bulwarks of civil and religious liberty—bastiles filled with prisoners, arrested without civil process or indictment duly found; the writ of *habeas corpus* suspended by executive mandate, &c." (See ANNUAL CYCLOPEDIA, 1861, *Habeas Corpus*.)

It was by such appeals as this that he sought to convince men of Union sentiments of the futility of all hopes for a restoration of the Union, unless at the sacrifice of their rights, their honor, and their independence. Unfortunately the facts alleged by him as existing under the Federal Government, were undeniable, and within the limits of the Confederacy they furnished powerful arguments with which to urge the justice of its organization, and the necessity of yield-



ing to it a most hearty support. The influence of such views upon the minds of the people must have been very favorable to the cause of the Confederacy, for they are advanced by President Davis on every opportunity.

Three days after the inauguration, a Message on the State of Affairs was sent to Congress by President Davis, in which he says: "Since my Message at the last session of the Provisional Congress, events have demonstrated that the Government had attempted more than it had power successfully to achieve. Hence in the effort to protect by our arms the whole territory of the Confederate States, seaboard and inland, we have been so exposed as recently to encounter serious disasters." To withstand these diasters, and to secure its successful existence, the only hope of the Confederate Government now was founded upon its own efforts and the mistakes of its adversary. Its efforts soon became of the most vigorous nature. The system of voluntary enlistments had furnished all the soldiers required during the first months of the war. These, however, had volunteered for short terms, under the expectation that there would be an early peace. To supply their places, as the term of enlistment expired, the Provisional Congress, in January, passed an act providing for receiving individual volunteers as they might offer their services without requiring a whole company to be formed and organized before they could be mustered in. It provided subsistence, transportation, and pay from the day of enlistment. Additional inducements were held out to those who might raise companies, battalions, or regiments. About the 1st of February a call upon the States for troops was made by President Davis, which he expected would be answered in full by the close of March. On the 25th of February the number of Confederate troops in the field was four hundred regiments of infantry, with a proportionate force of cavalry and artillery. The true position of the military at this time is found in these remarks of President Davis, made at the same date: "I deem it proper to advert to the fact that the process of furloughs and reenlistments in progress for the last month had so far disorganized and weakened our forces as to impair our activity for successful defence; but I heartily congratulate you that this evil, which I had foreseen and was powerless to prevent, may now be said to be substantially at an end, and that we shall not again during the war be exposed to seeing our strength diminished by this frightful cause of disaster—short enlistments."

The Confederate army of 1861 was composed chiefly of men enlisted for twelve months. These enlistments commenced immediately upon the secession of the States to which the troops belonged. The expiration of their terms of service therefore took place during the first months of 1862.

To meet this decrease of the army, the Provisional Congress offered, as above stated, in-

ducements to volunteers, and the President called upon the respective States to fill up their quotas of men to serve during the war. The number which had been demanded from each State was such as to make the proportion of troops in the field from each nearly equal. The minimum number for companies when mustered in as such was sixty-four privates and twelve officers. The call upon Mississippi was for seven regiments; on Alabama for twelve regiments; on Georgia for twelve thousand men; on North Carolina for five additional regiments. If the quota was not made up by volunteers, drafting was threatened by the Governors of the States.

These men, with those in service for the war and volunteers for twelve months who were expected to reenlist, were intended to form the armies of 1862. By the 1st of April the Government expected the whole body of new levies and reenlisted men to be ready in the ranks. The Federal Government, however, had brought its troops into camp during the latter part of 1861, and immediately commenced to organize and drill them, and prepare the immense materials necessary for an active campaign. It was thus at least four months in advance of the Confederate Government. The army of Gen. McClellan before Washington, hanging like an ominous cloud near the horizon, created much uneasiness at Richmond, but so long as the Confederate army remained at Manassas, no vigorous and active measures for future military operations were made. Amid this position of affairs, the Federal movements were ordered to be commenced on the 22d of February. Forts Henry and Donelson were captured, Bowling Green and Columbus evacuated, and Nashville surrendered. The entire Confederate line of defence in the West was swept away, and a march by the Federal troops into the heart of the Southwestern States was threatened. Consternation seized the Southern people. The Government was aroused to action, and the President sent the following cautious Message to Congress:

*To the Senate and House of Representatives of the Confederate States:*

The operation of the various laws now in force for raising armies has exhibited the necessity for reform. The frequent changes and amendments which have been made have rendered the system so complicated as to make it often quite difficult to determine what the law really is, and to what extent prior amendments are modified by more recent legislation.

There is also embarrassment from conflict between State and Confederate legislation. I am happy to assure you of the entire harmony of purpose and cordiality of feeling which has continued to exist between myself and the executives of the several States; and it is to this cause that our success in keeping adequate forces in the field is to be attributed.

These reasons would suffice for inviting your earnest attention to the necessity of some simple and general system for exercising the power of raising armies, which is vested in Congress by the Constitution.

But there is another and more important consideration. The vast preparations made by the enemy for a combined assault at numerous points on our frontier

and seaboard have produced results that might have been expected. They have animated the people with a spirit of resistance so general, so resolute, and so self-sacrificing, that it requires rather to be regulated than to be stimulated. The right of the State to demand, and the duty of each citizen to render military service, need only to be stated to be admitted. It is not, however, a wise or judicious policy to place in active service that portion of the force of a people which experience has shown to be necessary as a reserve. Youths under the age of eighteen years require further instruction; men of matured experience are needed for maintaining order and good government at home, and in supervising preparations for rendering efficient the armies in the field. These two classes constitute the proper reserve for home defence, ready to be called out in case of any emergency, and to be kept in the field only while the emergency exists.

But, in order to maintain this reserve intact, it is necessary that in a great war like that in which we are now engaged all persons of intermediate ages not legally exempt for good cause, should pay their debt of military service to the country, that the burdens should not fall exclusively on the most ardent and patriotic. I therefore recommend the passage of a law declaring that all persons residing within the Confederate States between the ages of eighteen and thirty-five years, and rightfully subject to military duty, shall be held to be in the military service of the Confederate States, and that some plain and simple method be adopted for their prompt enrollment and organization, repealing all of the legislation heretofore enacted which would conflict with the system proposed.

JEFFERSON DAVIS.

The 1st of April found not only the new levies and reenlisted men in the ranks, but the Confederate Congress, in compliance with the above Message, was about to pass a conscript law to bring all men between the ages of eighteen and thirty-five into the field. All furloughs were revoked by the following order from the War Department:

ADJUTANT AND INSPECTOR GENERAL'S OFFICE, }  
RICHMOND, March 24, 1862. }

*General Order, No. 18.*

All leaves of absence and furloughs, from whatever source obtained, are revoked; and officers and men absent from duty, except on surgeon's certificate of disability, will return at once to their respective commands. It is with extreme reluctance that the Department adopts a measure which deprives our patriotic soldiers of the relaxation they have so well earned; but the enemy presses on every side, and the necessities of the service demand new illustrations of that noble self-denial which has been so many times evinced since the commencement of our struggle for independence. The furloughs of all who have engaged for the war, which are thus curtailed, will be extended hereafter, when circumstances will permit. But judging from the past, no fears are entertained of an unwilling response to the call. Those who have so many times proved their devotion to their country, cannot be difficult or backward in the hour of her greatest need.

S. COOPER,  
Adjutant and Inspector-General.

Thus, although the Confederate losses were severe at first, they were soon prepared to meet the enemy. The danger which they escaped was thus stated at Richmond: "The disasters we have suffered are mortifying to us, and exhilarate our enemies; but they have startled without crippling the Confederacy. Had it lain still two months more, with the army dwindling daily under the furlough system, disgusted with the inaction of stationary

camps, while the Government was quarrelling with the generals, and the people sinking under indifference, we would have been overrun between the 15th of April and the 1st of May."

On the 16th of April the conscript act, having passed both Houses of Congress, was approved by the President. This act annulled all previous contracts made by volunteers, and by explicit terms made all men under the age of thirty-five years and over eighteen years, soldiers for the war, or until they attained the age of thirty-five years. It drew every male citizen within the prescribed ages immediately and entirely from the control of State action, and placed them at the disposal of the President during the war. It also provided, "That all persons under the age of 18 years, or over the age of 35 years, who are now enrolled in the military service of the Confederate States, in the regiments, squadrons, battalions, and companies hereafter to be organized, shall be required to remain in their respective companies, squadrons, battalions, and regiments for ninety days, unless their places shall be sooner supplied by other recruits, not now in the service, who are between the ages of 18 and 35 years, and all laws and part of laws provided for the reorganization of volunteers, and the organization thereof into companies, squadrons, battalions, and regiments, shall be, and the same are hereby repealed."

The existing organization of companies, regiments, &c., was preserved, but the companies were required to be filled up to the number of 135 men. When thus filled up, the privates had the privilege of electing their officers in the same manner as under former laws, but the commissions were issued by the President. The provision of the law annulling the contract with volunteers and requiring those under 18 years or over 35 to continue in service 90 days after its passage, without regard to their term of enlistment, was construed by these volunteers as entitling them to a discharge on the 16th of July. Previous to that date, however, an order was issued by the War Department placing them on the same footing as conscripts, and requiring them to continue in the service. So extreme was this order that it retained in service all enlisted men without regard to the time of their enlistment or their ages. Thus youths of 17 and men of 50 were not allowed to withdraw, nor any who were in the army at the time of the passage of the law. In a word, the law set aside all contracts, and the Government retained all the soldiers in the field and sought to add to them every man between the required ages. Not even physicians were exempted. President Davis, in a letter to the governor of Georgia, thus states the reason for this injustice to the volunteers:

I would have very little difficulty in establishing to your entire satisfaction that the passage of the law was not only necessary, but that it was absolutely indispensable: that numerous regiments of 12 months' men were on the eve of being disbanded, whose places would not be supplied by new levies in the face of su-

rior numbers of the foe without entailing the most disastrous results; that the position of our armies was so critical as to fill the bosom of every patriot with the liveliest apprehension, and that the provisions of the law were effective in warding off a pressing danger.

The regulations for executing the law detailed an officer to each State to take charge of the enrolment, mustering in, subsistence, transportation, and disposition of the recruits. The co-operation of State officers in making the enrolment was requested of the governors of the States, and in any cases in which such assistance might be refused, the duty was performed by officers of the army. Not more than two camps of instruction were established in each State, where the recruits were made ready for the field with the utmost despatch. The recruits were not organized in force as separate bodies, but were sent to supply deficiencies in regiments, battalions, squadrons, or unattached companies, and, so far as practicable, in corps from their own region of country. Recruits were allowed to choose any corps to which they desired to be attached, in which vacancies existed. They could also join any corps, the formation of which had been authorized by the Government. All 12 months' volunteers in service were required to reorganize by the election of new officers within 40 days after the act passed. Those who preferred a guerilla service were authorized to form as partisan rangers by an act specially passed for that purpose. The operation of the act was suspended in Missouri and Kentucky, under a provision authorizing it to be done by the President. Troops from those States were received under the acts passed previous to the conscription law. Maryland was regarded as exempt from the law, as appears by the following from the Secretary of War, dated April 26:

*Major J. A. Weston:*

In reply to your letter of the 17th inst., you are respectfully informed that Marylanders are not subject to the conscription act.

G. W. RANDOLPH, Sec. of War.

This extreme measure met with much opposition on the part of the people in the Southern States. It was an evidence, in itself, that the ardor of the people had ceased to be a safe medium of reliance in the conduct of the war. It was a measure which had never before been adopted in the States of the Union during any previous war. It necessarily established a consolidated government founded on military principles, and was thus spoken of by some of the Southern leaders:

If it be absolutely necessary to save us from a conquest by the North, we are willing to submit to it, but we fear the public mind must prepare itself for a great change in our government.

President Davis, in the letter to Governor Brown of Georgia, above mentioned, argued at much length that the act may be pronounced "constitutional" in spite of its seeming invasion of State rights, and said:

There seems to me to be a conclusive test on that whole subject. By our constitution, Congress may de-

clare war offensive as well as defensive. It may acquire territory. Now, suppose that, for good cause and to right unprovoked injuries, Congress should declare war against Mexico and invade Sonora. The militia could not be called forth in such case, the right to call it being limited "to repel invasion." Is it not plain that the law now under discussion, if passed under such circumstances, could by no possibility be aught else than a law to "raise an army?" Can one and the same law be construed into a "calling forth the militia," if the war be defensive, and a "raising of armies," if the war be offensive?

At some future day, after our independence shall have been established, it is no improbable supposition that our enemy may be tempted to abuse his moral power by depredations on our commerce, and that we may be compelled to assert our rights by offensive war. How is this to be carried on? Of what is the army to be composed? If this Government cannot call on its arms-bearing population more than as militia, and if the militia can only be called forth to repel invasion, we should be utterly helpless to vindicate our honor or protect our rights. War has been well styled "the terrible litigation of nations." Have we so formed our government that in litigation we may never be plaintiff? Surely this cannot have been the intention of the framers of our compact?

The most serious opposition to the act was manifested in the State of Georgia. The attempt was made to enrol militia officers holding commissions as such under the State authority. The following correspondence took place between the governor of that State and the Confederate Secretary of War:

ATLANTA, June 17, 1862.

Your enrolling officers have enrolled several of the State officers of the militia, who will not be permitted to be carried away from their commands. You stated in your letter of the 20th ultimo that no State officer is liable to enrolment, and asked me to call your attention to it if done. Please send me by telegraph an order for the release of all such who have been enrolled, and direct Major Dunwoody to stop the enrolment of State officers, or I shall order the arrest of each officer who arrests a State officer. I wish an immediate reply.

JOSEPH E. BROWN.

Hon. G. W. RANDOLPH, Sec. of War, Richmond.

The Secretary of War replied as follows:

RICHMOND, June 18, 1862.

Major Dunwoody has been instructed not to enrol militia officers recognized by the State authorities as in commission. Request him to show you his instructions. If you arrest him, or any of our enrolling officers, in their attempts to get men to fill up the Georgia regiments now in the face of the enemy, you will cause great mischief. I think we might as well drive out our common enemy before we make war on each other.

G. W. RANDOLPH, Secretary of War.

His Excellency Governor BROWN.

To this the Governor in answer said:

MARIETTA, June 23, 1862.

As Major Dunwoody's subordinates in different parts of the State do not seem to regard your orders to him, please direct him to give them the necessary instructions to stop the enrolment of the officers of the militia. I agree with you fully that we should unite all our energies to drive out the common enemy, and not make war among ourselves. I am most happy, therefore, that the Confederate Government has decided to respect the constitutional rights of the State so far as not to force her to the alternative of permitting any department of her constitutional government to be disbanded and destroyed, or to defend the existence and integrity of her government by force.

JOSEPH E. BROWN.

Hon. G. W. RANDOLPH, Sec. of War, Richmond.

Soon after, some measures were taken to test the constitutionality of the law before the courts of that State. James M. Levingood, who had been enrolled as a conscript, sued out a writ of *habeas corpus* before Judge T. W. Thomas, of the superior court in the county of Elbert, Georgia. The principal point made before the court was thus expressed: "The conscript act is unconstitutional, and therefore the act itself, and all regulations and orders based upon it, are likewise void." A lengthy opinion was given by the court, which concluded thus:

In the preamble of our Confederate Constitution care is taken to assert and maintain that the States are sovereign and independent. In what sense can this be said of Georgia, if every man of her militia can be taken from under the control of her constitutional commander-in-chief without his consent? Must he abdicate his most important duties by permitting himself to be disarmed of his forces, and all this too in violation of his oath of office, in case he should think them necessary for the protection of the State?

If Congress can pass a conscript act with certain exemptions, they can pass it without exemptions. No one will deny this. If, therefore, they have the power to prescribe what shall be militia and to conscribe at pleasure, they may take the governor, general assembly, and the whole judiciary, and thus annihilate the State government.

The palpable infraction of the Confederate compact is sometimes—indeed, principally—defended on the plea of necessity. What a dangerous fallacy! We have expended 100,000 lives and untold millions of money to maintain the constitution and the independence of the States, and shall we now violate it, and destroy the State government? As reasonably might we commit suicide to avoid personal danger.

Nor is this plea of necessity true in fact. The conscript law can only furnish men. We have, and had before, State laws to reach every man in the State between 18 and 45, and to say the conscript law was necessary to procure men is to maintain the arithmetical absurdity that there is more men in the country between 18 and 35 than between 18 and 45.

Whereupon, and for these reasons, it is ordered and adjudged by the court that the act of the Confederate Congress known as the conscript law, and entitled "An act to further provide for the public defence," is void; and the plaintiff, James M. Levingood, be released and discharged from the custody and control of Sidney P. Bruce, and from the custody and control of the sheriff of this court, and be set at liberty, to go wherever he pleases.

The case was immediately carried up to the Supreme Court of the State, which overruled this decision.

Subsequently, on the approach of the Federal forces into Camden county, an application was made to Governor Brown for authority to call out the local militia for its defence. Instead of authorizing the call of the non-conscripts, he laid the subject before the Legislature. The joint committee to whom it was referred were divided. A majority reported most decisive resolutions against the constitutionality of the conscript act, but the minority recommended acquiescence in the measures of the Confederate Congress. (*See GEORGIA.*) While the discussion was going on in the Legislature, the subject was taken up before the people, and Mr. A. H. Kenan, a member of the Confederate Congress, delivered a public address at Milledgeville, the seat of government, in which he thus stated

that their safety depended on the success of the conscription law:

Georgia is the last State that ought to complain and resist this law. Georgia has not yet been invaded. We have not yet suffered at our doors and in our estates from the presence of a hostile foe. The battles in our defence have been fought hundreds of miles away from us. The Virginians have suffered in person and property to an extent that you who are at home and far from the enemy cannot appreciate. You have never had your patriotism and devotion to our cause and country tested. The people of Virginia have lost their property, their negroes, their food, their all. Their houses, their barns and fences have been burned before their eyes, their wives and children insulted and driven from home, and themselves carried away captives, and still they are true. You know nothing of the ravages of war. When you and your wives and children are driven from home without food and clothing, to hide in the mountains and caves, your negroes stolen and the torch applied to your premises, then your patriotism will be tested. Can you endure that? Had you not better do all you can to keep the war away from your borders? Is it well for you to be squabbling about State rights and who shall appoint captains and colonels when the enemy is thundering at your doors? We have had brilliant victories, and our arms have performed such deeds as history has nowhere recorded. Conscription has done it for us. If this war goes on, we have to whip 500,000 of the best men the enemy has got before next spring, or they will whip us. If we whip them, conscription will have done it—without it we will fail.

In Alabama a citizen not exempt under the law, was elected a justice of the peace. The probate court refused to accept his bond on the ground that he was ineligible, being between the ages of 18 and 35, and virtually a conscript. An application was made to the circuit court for a mandamus to the probate court. The circuit court, Judge Henry, ruled: 1st. That the probate court had no right to inquire into the question of eligibility. 2d. The court also ruled, *obiter dictum*, that by the passage of the conscript law, and the call of the President, and instructions of the Secretary of War, every man between the ages fixed by the law was virtually a conscript, and could not, by having office cast upon him subsequently, escape the conscription.

These were the most important instances of opposition to the law. All methods were resorted to by private individuals to escape its operation which the most skilful ingenuity could devise. In the city of Mobile, nearly 500 men of the ages subject to military duty, applied for and received certificates of citizenship from consular agents. These were certificates of their allegiance to other powers than the Southern Confederacy. Others took shelter under the exemptions to be found in the militia laws of the State Legislatures. This, in some instances, was acquiesced in by the Confederate authorities, although the conscript law did not recognize any acts of State Legislatures.

The call of the President was for the whole body of men between the ages of eighteen and thirty-five. Immediately after the publication of the call the enrolment commenced. Much time elapsed during the preliminary arrangements and it was not until the month of June

that the benefits of the conscription began to be felt in the increase of the armies. Although the act declared every man a soldier with a few exceptions, between certain ages, yet the number of exempts was comparatively large and the number of conscripts less than might be supposed. A certain number were exempted in proportion to the number of slaves; the officers of the Confederate and State Governments, those incapable from physical disability, clergymen, persons engaged in Government work and some others exempted from militia duty by State laws. Still during the summer months the Confederate force largely outnumbered the Federal armies, and caused the issue by President Lincoln in July, of a call for three hundred thousand men for the war and an additional three hundred thousand for nine months.

The usual consequences of the enforcement of a conscription law were apparent in this instance. While the enrolment was going forward, substitutes were sought out and engaged at bounties from one hundred to two thousand dollars. It became such a serious evil in the city of Richmond as to cause the issue of the following order :

HEADQUARTERS, DEPARTMENT OF HENRICO, }  
RICHMOND, Va., August 1, 1862. }

The obtaining of substitutes through the medium of agents is strictly forbidden. When such agents are employed, the principal, the substitute and the agent will be impressed into the military service, and the money paid for the substitute, and as a reward to the agent, will be confiscated to the Government. The offender will also be subjected to such other imprisonment as may be imposed by a court martial.

By order of Brigadier General JOHN H. WINDER, commanding Department, &c.

I. R. PAGE, Assistant Adjutant-General.

Desertions also followed in such vast number as to call for the interference of the War Department. The following orders were accordingly issued from that quarter :

WAR DEPARTMENT, ADJT. AND INSP. GENERAL'S OFFICE, }  
RICHMOND, June 18, 1862. }

I. With the consent and approbation of his Excellency Governor Letcher, all sheriffs, deputy sheriffs and constables of the State of Virginia are authorized and requested to apprehend deserters from the army wherever they may be found, and to deliver them to an officer of the army at the most convenient post or station, or to lodge them in jail, and report their names and regiments to General S. Cooper, Adjutant and Inspector General, Richmond.

Thirty dollars will be paid for all deserters delivered to an officer and fifteen dollars for each deserter lodged in jail. No allowance will be made for expenses of apprehension or transportation. All jailors receiving deserters are requested to detain them. The usual allowance for the support of prisoners will be made.

II. Transfers from the line to partisan corps will not be permitted, and if any officer of partisan corps knowingly enlist them from the line, the authority to raise the partisan corps will be revoked in addition to such punishment as a court martial may inflict.

By command of the Secretary of War.

S. COOPER, Adjutant-General.

WAR DEPARTMENT, ADJT. AND INSP. GENERAL'S OFFICE, }  
RICHMOND, July 14, 1862. }

General Orders No. 49.

All persons engaged in enrolling conscripts are hereby authorized and required to arrest deserters

from the army and to deliver them to the commandant of the nearest camp of instruction, or to lodge them in the nearest jail, and to return their names, company, and regiment to the Adjutant and Inspector General. Jailors are requested to detain them, and will be allowed the fees and charges for the detention of prisoners prescribed by the laws of the State in which the jail is situated.

Enrolling officers are also required to report to the Adjutant and Inspector General the names and address of all persons absent from the army without leave, whether by the expiration of their leaves of absence, furloughs, details, or otherwise. And where this unauthorized absence exceeds the time required to correspond with the War Department, the enrolling officer will arrest the person and send him to the nearest camp of instruction, reporting the arrest to the Adjutant and Inspector General.

Commandants of camps of instruction are required to forward deserters and persons absent without leave to their regiments, and have the powers of arrest conferred upon the enrolling officer.

By command of the Secretary of War.

S. COOPER Adjutant and Inspector General.

Circular to Officers enrolling Conscripts.

ADJUTANT AND INSPECTOR GENERAL'S OFFICE, }  
RICHMOND, July 14, 1862. }

Agreeably to General Orders No. 49, current series, this day published, you are required to arrest all deserters, and, under certain circumstances, all persons absent from the army without leave.

The public welfare requires you to discharge this duty, and the more important duty of enrolling conscripts, with the utmost activity, and without fear, favor, or affection.

Our capacity to improve the brilliant victories now favoring our arms depends mainly upon your exertions to fill the ranks of our armies.

If you are zealous and active we shall make our enemy taste the bitterness of war; if you are negligent we shall continue to witness its ravages on our own soil.

By command of the Secretary of War.

S. COOPER,

Adjutant and Inspector General.

This circular was issued just before the invasion of Maryland was commenced.

The public press appealed to the citizens in all parts of the South to assist in the apprehension of deserters and stragglers from the army "by giving information to the authorities of the place of refuge of these creatures." They said: "There should be no resting place for the feet of these creatures. Every man and woman in the country is able to do something in pursuing, shaming, and driving back to the ranks those who have deserted their colors and their comrades and turned their backs upon their country's service. Let all ages and sexes in the country assist the Government in reclaiming deserters and stragglers, and in maintaining the integrity of our army. We trust this exhortation will not be lost upon the country. Desertions are reducing our army, defying its discipline, corrupting its spirit and morals, and seriously endangering the fortunes of our cause."

The unrelenting vigor with which this work of conscription was pushed forward was sufficient to bring out the full power of the Confederacy. The defeat of these armies would necessarily have taken away the principal strength of its military resistance.

At the time when the conscript law was passed by the Confederate Congress, another act, to provide for Partisan Rangers, was also adopted. It was as follows:

"An act to organize bands of Partisan Rangers:"

SECTION 1. *The Congress of the Confederate States of America do enact*, That the President be and he is hereby authorized to commission such officers as he may deem proper, with authority to form bands of Partisan Rangers, in companies, battalions or regiments, either as infantry or cavalry, the companies, battalions or regiments to be composed, each of such number as the President may approve.

Sec. 2. *Be it further enacted*, That such Partisan Rangers, after being regularly received into the service, shall be entitled to the same pay, rations and quarters, during their term of service, and be subjected to the same regulations as other soldiers.

Sec. 3. *Be it further enacted*, That for any arms and munitions of war captured from the enemy by any body of Partisan Rangers, and delivered to any quartermaster at such place or places as may be designated by a Commanding General, the Rangers shall be paid their full value in such manner as the Secretary of War may prescribe.

Approved April 21, 1862.

Its practical operation is fully set forth in the following correspondence between a member of the Senate from Missouri and the Secretary of War:

SPOTSWOOD HOTEL, RICHMOND, July 15, 1862.

Hon. GEORGE W. RANDOLPH, Secretary of War:

SIR—I respectfully desire to know from you whether the several Partisan Corps of Rangers, now organized or that may be organized in the several States of the Confederacy, are to be regarded as part of the army of the Confederacy, and protected by the Government as such; and whether, if any of said corps are captured in battle, or otherwise while in the line of their duty, by the enemy, this Government will claim for them the same treatment, as prisoners of war, which is now exacted for prisoners belonging to our provisional army.

Are not all Partisan Rangers, organized by your authority, emphatically a part of the Confederate army, and will they not be regarded and treated as such?

I consider that it is not only the right, but the duty of every loyal citizen of the Confederate States, to resist, by all means in his power, even to the death, if necessary, the attempt of the enemy in a body or singly to invade his domicile or to capture his person, or that of his wife, child, ward, or servant, or to take from him against his will any of his property; and if, in making such resistance, whether armed or not, our citizens are captured by such invading enemy, have they not the right to demand to be treated by the enemy as other prisoners of war; and will not this Government exert all its power, if necessary, to the end that its citizens are thus protected and treated?

This is a war waged against the sovereignty of the several States of the Confederacy, and against the lives liberty and property of every citizen yielding allegiance to the States and Government of their choice, in which they reside. Such a war has no parallel in the history of Christian nations.

I respectfully request you to give me your opinions on the several points in this letter, in a form to be submitted to my constituents, to enlighten them in regard to the extent of their rights and powers as viewed by this Government, and how far their Government will protect them in the exercise of those rights, which, to an intelligent freeman, are dearer than life itself. Your early answer is respectfully requested. With great respect,

JOHN B. CLARK.

CONFEDERATE STATES OF AMERICA, }

WAR DEPARTMENT, RICHMOND, Va, July 16, 1862. }

Hon. John B. Clark, Confederate States Senate:

SIR—I have the honor to acknowledge the receipt of your letter of the 15th instant, and to reply, that Parti-

san Rangers are a part of the provisional army of the Confederate States, subject to all the regulations adopted for its government, and entitled to the same protection as prisoners of war. Partisan Rangers are in no respect different from troops of the line, except that they are not brigaded, and are employed oftener on detached service. They require stricter discipline than other troops to make them efficient, and without discipline they become a terror to their friends and are contemptible in the eyes of the enemy.

With reference to your inquiry as to the protection which the Government will extend to private citizens taken in hostile acts against the enemy, it is not easy to lay down a general rule.

War, as conducted by civilized nations, is usually a contest between the respective governments of the belligerents, and private individuals, remaining quietly at home, are respected in their rights of person and property. In return for this privilege they are expected to take no part in hostilities, unless called on by their government.

If, however, in violation of this usage, private citizens of Missouri should be oppressed and maltreated by the public enemy, they have unquestionably a right to take up arms in their own defence, and if captured and confined by the enemy, under such circumstances, they are entitled, as citizens of the Confederate States, to all the protection which that Government can afford; and among the measures to which it may be useful to resort is that of the *lex talionis*.

We shall deplore the necessity of retaliation, as adding greatly to the miseries of the war, without advancing its objects; and, therefore, we shall act with great circumspection, and only upon facts clearly ascertained. But if it is our only means of compelling the observance of the usages of civilized warfare, we cannot hesitate to resort to it when the proper time arrives. Very respectfully your obedient servant.

GEORGE W. RANDOLPH, Secretary of War.

Notwithstanding these extreme efforts by the Confederate Government to obtain men, such was the power of its adversary, now marshaling nearly six hundred thousand fresh volunteers for the field, and such the reduction of the Confederate forces by desertion, sickness, and losses in battle, that renewed exertions were demanded. The Confederate Congress, therefore, in September, passed another act of conscription, calling out every man between the ages of thirty-five and forty-five, and all youths as soon as they became eighteen years of age. The important part of the act was as follows:

An act to amend an act, entitled "An act to provide further for the public defence," approved April 16, 1862.

*The Congress of the Confederate States of America do enact*, That the President be, and he is hereby authorized, to call out and place in the military service of the Confederate States, for three years, unless the war shall have been sooner ended, all white men who are residents of the Confederate States, between the ages of thirty-five and forty-five years, at the time the call or calls may be made, and who are not at such time or times legally exempted from military service; or such parts thereof as, in his judgment, may be necessary to the public defence, such call or calls to be made under the provisions and according to the terms of the act to which this is an amendment; and such authority shall exist in the President, during the present war, as to all persons who now are, or may hereafter become, eighteen years of age; and, when once enrolled, all persons between the ages of eighteen and forty-five years shall serve their full time; Provided, That if the President, in calling out troops into the service of the Confederate States, shall first call for only a part of the persons, between the ages hereinbe-

fore stated, he shall call for those between the age of thirty-five, and any other age less than forty-five; Provided, that nothing herein contained shall be understood as repealing or modifying any part of the act to which this is amendatory, except as herein expressly stated; and Provided further, that those called out under this act, and the act to which this is an amendment, shall be first and immediately ordered to fill to their maximum number the companies, battalions, squadrons, and regiments from the respective States at the time the act to further provide for the public defence, approved 16th April, 1862, was passed; and the surplus, if any, shall be assigned to organizations formed from each State since the passage of that act, or placed in new organizations, to be offered by the State having such residue, according to the laws thereof, or disposed of as now provided by law; Provided, that the President is authorized to suspend the execution of this, or the act to which this is an amendment, in any locality where he may find it impracticable to execute the same; and that in such localities, and during such suspension, the President is authorized to receive troops into the Confederate service under any of the acts passed by the Confederate Congress prior to the passage of the act further to provide for the public defence, approved 16th of April, 1862.

On the 8th of October President Davis, in a Message to Congress, relative to incompetent army officers, stated that numerous regiments and companies had been so reduced by the casualties of war, by sickness and other causes, as to be comparatively useless under the existing organization. There were companies in the army in which the number of officers exceeded that of the privates present for duty, and regiments in which the number of such privates did not exceed that which was required for a single effective company.

Such were the measures by which the Confederate Government succeeded in obtaining men for its armies during 1862. It was equally deficient at the beginning of the year, in the munitions of war. When the new levies came forward, at the call of the President at the beginning of the year, the Ordnance Department had not the arms for them. The Government issued a call upon the people for their shot guns as follows:

HEADQUARTERS ORDNANCE DEPARTMENT, }  
RICHMOND, Va., March 28, 1862. }

This department is desirous of purchasing arms from those parties having good double barrel shot guns, sporting rifles, or any kind of weapon that will be useful in the field. These arms will be fairly appraised on their delivery in Richmond, and payments will be promptly made. Agents heretofore collecting State arms for this department are requested to collect and forward these private arms as promptly as possible.

O. DIMMOCK, Colonel of Ordnance of Virginia.

Of the fifty-nine regiments of infantry, one regiment of cavalry, and eleven cavalry battalions sent into the field from Tennessee, the Confederate Government had found arms for only fifteen thousand of them, and the remainder were furnished with the shot guns obtained from the citizens.

Official calls were also made by the Government for sulphur, lead, and saltpetre. The advance in the price of the latter article caused the Secretary of War to issue the following order:

CONFEDERATE STATES OF AMERICA, }  
WAR DEPARTMENT, February 4, 1862. }

Bands of speculators have combined to monopolize all the saltpetre to be found in the country, and thus force from the Government exorbitant prices for an article indispensable to the national defence. The department has hitherto paid prices equal to four times the usual peace rates, in order to avoid recourse to impressment, if possible. This policy has only served to embolden the speculators to fresh exactions. It is now ordered that all military commanders in the Confederate States impress all saltpetre now or hereafter to be found within their districts, except such as are in the hands of the original manufacturers, or of Government agents and contractors, paying therefore forty cents per pound, and no more. The price fixed is the highest rate at which contracts have been made, and leaves very large profits to the manufacturer.

J. P. BENJAMIN, Secretary of War.

The deficiency of light artillery was so great that the Government issued the following notice:

The Ordnance Bureau of the Confederate States solicits the use of such bells as can be spared during the war, for the purpose of providing light artillery for the public defence. While copper is abundant, the supply of tin is deficient to convert the copper into bronze. Bells contain so much tin that 2,400 lbs. weight of bell metal, mixed with the proper quantity of copper, will suffice for a field battery of six pieces. Those who are willing to devote their bells to this patriotic purpose will receive receipts for them, and the bells will be replaced, if required, at the close of the war, or they will be purchased at fair prices.

Bells may be directed as follows: Richmond Arsenal, Richmond, Va.; Fayetteville Arsenal, Fayetteville, N. C.; Charleston Arsenal, Charleston, S. C.; Augusta Arsenal, Augusta, Ga.; Mount Vernon Arsenal, Mount Vernon, Ala.; Columbus Depot, Columbus, Miss.; Atlanta Depot, Atlanta, Ga.; Savannah Depot, Savannah, Ga.; Knoxville Depot, Knoxville, Ga.; Baton Rouge Arsenal, Baton Rouge, La.; Montgomery Depot, Montgomery, Ala.

The Government will pay all charges to these places, and receipts will be promptly returned to the proper parties.

Persons and congregations placing their bells at the service of the Government, are requested to send a statement of the fact, with a description and weight of the bell, to the Chief of the Bureau of Ordnance, at Richmond, for record in the War Department.

At the same time Gen. Beauregard, in command at the Southwest, issued an appeal to the people to contribute their church bells to be manufactured into cannon. In response to these calls, the stewards of St. Francis street Methodist church, in Mobile, met and voted to send their bell to the Government foundery. The Presbyterian, Methodist, and Episcopal churches in Marietta, Ga., sent forward their bells. The Methodist, Presbyterian, Episcopal, Cumberland Presbyterian, and Baptist churches in Huntsville, Ala., sent forward their bells, weighing 4,259 pounds. These were considered sufficient to make two batteries of six guns each. The church bells of Fredericksburg, weighing in the aggregate 4,500 pounds, were tendered to the Government. The planters of Louisiana sent forward the bells used on their plantations. The public prints contained notes like the following:

MESSRS. EDITORS: I see Gen. Beauregard has called for bells, to be manufactured into cannon. Cannot the

ladies assist by sending all their bell metal—preserving kettles? I send mine as a beginning.

A SOUTHERN WOMAN.

MOBILE, March 19, 1862.

MESSES. EDITORS: I see a call made through your paper for the ladies of Mobile to send their old brass to make cannon for the defence of our beloved city. I, therefore, send you my mite, hoping that, small as it is, it may be of some use. With many prayers for the success of our beloved cause, I remain, yours respectfully.

GENTS: I send you, as a contribution to the Confederacy, the lead weight which was attached to the striking part of my clock, with the hope that every one, not only in our city but in the whole Confederacy, who may have such within their reach, will do likewise.

But there were other and more important sources for the supply of the munitions of war. Arms must be had or the Government would be vanquished. Swift steamers, freighted in England, were sent out to run the blockade, and while many were captured, others succeeded in reaching port. The value of their cargoes, and that of the cotton obtained for the return voyage, was more than sufficient to compensate the owners for the loss of two or three vessels. Munitions of war were also obtained from Mexico, whither they had been sent from Europe, and transported through Texas. Large quantities of small arms, clothing, and army wagons were captured from the United States. Manufactories were also put in operation extensively in the Confederate States, and at the close of the year the Government was better supplied with the munitions of war than at any previous period.

The plan of defensive operations adopted by the Provisional Government at the commencement of the war was from necessity continued. At the beginning of the year the Confederate armies were pushed forward to extreme positions on the territory claimed as a part of the Confederacy. On the North their line extended from Columbus, Kentucky, eastward through Bowling Green, the Cumberland river post, with advances on the Big Sandy and Kanawha rivers, Staunton, Winchester, Leesburg, Centreville, Aquia Creek and the Potomac. The weak points presented by the Tennessee and Cumberland rivers were strongly guarded by Forts Henry and Donelson. This line was on the verge of the Northern States, and any advance from that quarter would soon meet with resistance. It was quietly occupied chiefly by twelve months' volunteers, confident of their ability to maintain their ground and feeling a degree of contemptuous defiance of their adversary. The comparative inactivity of the Federal forces since their defeat from Bull Run had lulled the apprehensions of the Southern people, and even the Confederate Government was reposing under an impression of security. This apparent inactivity of the Federal forces, however, concealed careful and laborious preparations for a most formidable and overwhelming campaign. An expedition had been sent to Port Royal, South Carolina, and another subsequent-

ly to North Carolina, not only to serve the purpose of seizing important localities and assisting the blockade, but to divert the attention of the Confederate Government from the magnitude of the armies preparing at Washington, Louisville, and Cairo. The only effect which they produced upon the Confederate Government was to occupy its attention and move it to call for new levies to take the place of the twelve months' volunteers whose terms of enlistments soon expired. In this posture of affairs the Federal army was ordered by the Government to move even in the middle of winter, and while nearly half its gunboats at the West were without men. It swept the Confederate line of defence away from near Cumberland Gap to the Mississippi, which it relieved of blockade above and advanced into Arkansas beyond the river, and it opened the eyes of the Confederate Government to the real dangers of its position. A new line of defence was immediately adopted, intended to command the railroad system of the Southwest. It extended from Memphis on the west through Grand Junction, Corinth and Chattanooga. But the most vigorous and determined efforts, as above stated, were made by the Government to turn the tide of disasters that set in upon it. Circumstances favored its efforts. The Federal army at the West, having pushed into the field in an incomplete condition, was now forced to move slowly in order to secure its effectiveness. Nothing of importance was done by it after the capture of Fort Donelson and the escape of a part of it from destruction at Shiloh, until the end of May, when Corinth was acquired. The eastern portion of the line of defence remained unchanged sometime after it had been lost at the West, and was finally evacuated. The difficulties arising from the weather, the incomplete state of preparations, and the repeated changes in the destination of some of the forces for the campaign so retarded the army of the Potomac that it did not pass Yorktown and Williamsburg and begin to move directly upon the Confederate capital until the middle of May. Even at that period, so incomplete were the preparations of the Confederate Government for the great defence they were required to make, that Richmond was filled with consternation. The state of excitement there is thus described by an officer of the Confederate army: "All who could possibly get away packed up everything they had and fled southward. The nearer the hostile army approached the city the fiercer the tumult and uproar became. The burning waves of popular alarm could not be stayed. The Government itself furthered the confusion. Instead of resolving to triumph or to fall with the army in front of Richmond, it at once ordered all the different bureaux to pack up, and caused the officers of ordnance to empty the magazines and convey their stores further south. Even President Davis took to the road and hastened, with his wife and children,



to North Carolina. As may be readily divined, this loss of presence of mind threw the people at large in the most frantic excess of terror. There was nothing on all sides but shouting and uproar, and confusion reached its utmost height. The secret police of Gen. Winder had lost all control. The civil authorities of Richmond were anxious to do something, but knew not what, and also lost their senses. A small number of the Baltimore rabble took advantage of the hubbub, and, in public meeting, passed resolutions condemning Richmond to conflagration so soon as the Union troops should enter it. Yet all who could escape did so. The sick and the wounded were carried farther into the interior; many public and private buildings were marked out for destruction; and, in short, a frightful catastrophe seemed to be impending over the Southern capital."

This contraction of the line of defence produced a greater concentration of forces and a capacity for more powerful resistance. At the same time the coast line of defence had been abandoned, and with the loss of the harbors of North Carolina and Florida, Fort Pulaski and New Orleans, the forces were withdrawn to interior lines. The first step of the Government under this aspect of affairs was to render Richmond impregnable. The next was to take such measures as would disperse the powerful force threatening it on the Chickahominy. The Federal Government was led to believe by rumors thrown out for the purpose, that the force of Gen. Jackson was designed, after defeating Gen. Banks, to march upon Washington or cross into Maryland, and reinforcements were sent forward to confirm the deception. It was successful. But Gen. Jackson was immediately brought back to cooperate in an attack on the flank and rear of the Federal army on the Chickahominy at the same time that it was assailed in front by Gen. Lee. The plans were successful. The Federal army was forced back upon the James river and finally evacuated the peninsula. The condition was now entirely changed. The Confederate forces were triumphant, while their enemy was everywhere reduced. It was determined to make the latter "taste of the bitterness of war." A Confederate campaign in Maryland and Kentucky was resolved upon, "to obtain meat and bread and munitions of war." The Confederate States at this time were exhausted, in consequence of supporting not only their own population, but the armies of friend and foe. It was thus argued:

The great and true source of meat supply is the State of Kentucky. If our armies could push directly forward on that State and occupy it to the banks of the Ohio, the political advantages secured to the South would be of no small account compared with those she would derive in a sumptuary point of view. There are more hogs and cattle in Kentucky available for general consumption, two or three to one, than are now left in all the South besides, and steps ought to be taken by Government to drive these animals, as well as mules and horses, as the armies march forward, and place them within our lines. It is not only

positively important to us that these animals should be promptly secured as they fall within our grasp, but it is negatively so also, in depriving the enemy of the convenient supplies of meat for their army which they have derived from Kentucky. In this point of view the campaign in Kentucky becomes doubly important, and assumes an interest as great as that in Maryland.

The capture of the stores at Manassas Junction and Harper's Ferry, and the spoils taken from Kentucky, were of immense service to the cause. The results of the campaign, however, developed to the Government the first fact of the war, which was that it could not carry on an offensive war against the North. Its military plans for the remainder of the year were confined to annoying the enemy, to preserving Richmond from danger, and to keeping up the blockade of the Mississippi by holding the strong positions of Vicksburg and Port Hudson. (*See ARMY, CONFEDERATE, and ARMY OPERATIONS.*)

The civil organization of the Government was as follows:

*Secretary of State*—J. P. Benjamin, of Louisiana.  
*Secretary of War*—George W. Randolph, of Virginia.  
*Secretary of the Navy*—S. R. Mallory, of Florida.  
*Secretary of the Treasury*—C. G. Memminger, of S. C.  
*Attorney General*—Thomas H. Watts.  
*Postmaster General*—James H. Reagan, of Texas.

In November the Secretary of War resigned, and James A. Seddon, of Virginia, was appointed to his place. He was one of the commissioners sent by the Virginia Legislature to the Peace Conference at Washington in 1861, and had been a Representative to Congress from 1845 to 1847, and from 1849 to 1851.

The finances of the Confederate States have apparently not improved during the past year. The only dependence has been upon issues of paper money, which have followed their natural tendency to depreciation and ultimate worthlessness. It is probable that in the isolated condition of the Confederacy, being cut off from external intercourse, paper may float to better advantage in the currents of internal trade than where similar issues, as at the North, are exposed by commercial transactions to continual contact with the specie currencies of the countries with which commerce is conducted. On the other hand, the Confederate system of finance has lacked the support which, with a powerful navy to keep its commerce open, it might have had from the duties on imports and upon the exports of cotton. Those two items were made a dependence for certain loans early in the war, but they have failed to realize the expectations based upon them. The first loan authorized, that of Feb. 23, 1861, was on a very sound principle, had it been possible to export cotton. The act provided for a loan of \$15,000,000, bearing 8 per cent. interest, to be discharged by a duty of about 55 cts. per bale of cotton exported. It was supposed that the product for 1862 would be \$2,200,000, which would pay the interest \$1,200,000, and \$1,000,000 of the principal. This operation, with an increasing crop of cotton, would, it was estimated, discharge the debt in 1870. The debt was contracted, but the duty is not forthcoming. This money was soon ex-

hausted; and the war assuming greater proportions, on the 16th of April, 1861, a law authorized the issue of Treasury notes, bearing 7 $\frac{3}{4}$  interest, fundable in 8 per cent. Confederate bonds, and payable on demand in currency. In Aug. 1861, the authority was extended to the issue of notes not bearing interest, but fundable in 8 per cent. Confederate bonds. These issues immediately began to affect prices and cause an apparent rise in the value of gold, which indeed immediately disappeared from circulation, being hoarded by those who had the means; and in August, 1861, it was at 12 per cent. premium at Richmond. The downward tendency in the value of the paper produced its usual effects. Money was apparently very plenty, with an evident growing scarcity of capital; and on the 24th of Dec. 1861, Congress authorized the receiving of the paper money on deposit, in exchange for certificates bearing 6 per cent. interest. These certificates were payable on demand at any time in currency. There were thus, at the commencement of 1862, three classes of paper, the 7 $\frac{3}{4}$  notes fundable in 8 per cent. bonds, the currency notes also fundable, and the call certificates bearing 6 per cent. These all performed more or less the functions of currency. Congress then authorized an issue of \$1 and \$2 notes, and also a limited amount of two-year notes. The premium on specie had now risen to 50 per cent., and but a small amount of capital had been really subscribed to the loans of the Government. Indeed it was not to be expected, inasmuch as that the mass of Southern capital was locked up by the war. The great staples of cotton, rice, tobacco, naval stores, lumber, corn, &c., which are exported in usual years, remained on hand in useless accumulation. The owners would subscribe to the Government wants if they could sell their produce. The subscriptions to this loan were very ample, but when the time came to realize they were found very difficult to be turned into money. On April 21st, 1862, an act was passed by the Permanent Government, which provided that the Government should take the products of the field and issue 8 per cent. bonds to the owners, under the following form of agreement:

In consideration of \_\_\_\_\_ dollars, paid me in bonds of the Confederate States, I \_\_\_\_\_, of the county and State aforesaid, have sold to the Confederate States of America, \_\_\_\_\_ bales of cotton, marked and numbered as in the margin, now deposited at \_\_\_\_\_ (naming location of plantation), and I hereby agree to take good care of the said cotton while on my plantation, and to deliver the same, at my own expense, at \_\_\_\_\_ (naming the usual shipping point), in the State of \_\_\_\_\_, to the order of the Secretary of the Treasury, or his agents, or his or their assigns.

The agreement must be endorsed by an agent, who certifies to the quality, quantity, weight, condition, and market value of the cotton; that it is under secure cover, and has been marked with the name of the planter and the initials of the Confederate States.

The bonds of the Confederate States draw

interest at 8 per cent., payable semi-annually by the Treasury agent in each State, which is secured by the war tax or an export duty on cotton. The purchases thus made, together with the collections on the loan, at the close of the year, amounted to nearly \$13,000,000, and, it is reported, were negotiated. The total amount of subscriptions to the loan, valued in money, was about twenty-five millions of dollars, of which \$7,631,044 were collected at an expense of one third of one per cent. The purchases of cotton thus far reported by the agents amount to 69,507 bales, costing \$4,474,400. The purchases a few months later probably reached 250,000 bales. In order to dispose of the cotton, two forms of certificates were devised. By one the various parcels of cotton were registered and disposed of. By the other the Government obligated itself to deliver certain quantities at certain points at a fixed price. By the advice of ministers abroad some of the latter certificates, covering about 30,000 bales of cotton, have been placed as an experiment in the foreign market.

Congress, on the 12th of April, 1862, authorized a loan at 8 per cent., payable in from 10 to 30 years, but no bonds were issued under the act. The \$100,000,000 loan, into which notes are fundable, is also an 8 per cent. loan, and is made payable in instalments, which fall due every six months in eighteen years, from the 1st of January, 1864. The first instalment of the principal of \$1,288,700 is payable 1st of January, 1864; the second, of \$1,340,200, is payable 1st of July, 1864.

The expenditures of the Government continued to be met in paper money, and according to the official report made to Congress on August 1, 1862, the revenue and expenditures up to that date had been as follows since the commencement of the war:

Expenditures—War department .....	\$293,376,549 41
Navy department .....	14,605,777 86
Civil and miscellaneous .....	15,766,508 48
Total .....	\$293,748,836 75
Outstanding requisitions .....	13,524,123 15
Total expenditure, February, 1861, to August, 1862 .....	\$307,272,960 85
Total receipts, Feb. 1861, to August, 1862 .....	302,481,096 60

Deficient Treasury notes authorized .....	\$16,755,165 00
Do. to be provided .....	23,083,697 25— \$44,730,862 25

The receipts were derived as follows:

Customs .....	\$1,437,399 96
War tax .....	10,589,910 70
Miscellaneous .....	1,974,769 83— \$13,952,079 99
Loans—Bonds, February, '61, 8 per cent. ....	\$15,000,000 00
Bonds, August, '61, 8 per cent. ....	22,613,346 61
Call certificates, Dec. 1861, 6 per cent. ....	87,515,200 00
Treasury notes, April, 1861, 7 $\frac{3}{4}$ per cent. ....	22,799,900 00
Demand notes, August, '61, no interest .....	187,190,670 00
\$1 and \$2 notes .....	844,900 00
Due banks .....	2,625,000 00— \$383,531,016 61
Total receipts .....	\$302,483,096 60

The customs collected were mostly before the

blockade became very rigid. The war tax was paid in by the several States about as follows:

North Carolina.....	\$1,400,000 00
Virginia.....	2,125,000 00
Louisiana.....	2,500,000 00
Alabama.....	2,000,000 00
Georgia.....	434,126 12
Florida.....	325,874 11
Mississippi.....	1,484,467 67
Total.....	\$10,168,967 90

The State of Georgia has substantially paid in the balance due by her, and the State of South Carolina paid the whole amount due by her into the Treasury, in the form of 6 per cent. call certificates. The States of Alabama and Louisiana paid their taxes in advance.

Thus the whole amount of funded debt at that date was a little over 37 millions. The balance was mostly due on demand serving for money, and authority then existed to issue 20 millions more paper under the law. Under this operation the depreciation of the currency was further marked by the prices of commodities. Some of the quotations were in Richmond as follows: gold 140 per cent., equal to 42 cents per dollar for paper. Flour was \$14.50 in paper, or \$6 in specie; corn \$2 in paper, or 80 cents in specie; wheat \$3.30 in paper, or \$1.30 specie; rye \$2.50 in paper, or \$1 specie; butter \$1 in paper, or 42 cents specie; wool \$1 in paper, or 42 cents specie; coffee (Rio) \$2 paper, or 84 cents specie; brown sugar was 65 cents paper, or 26 cents specie. For those articles like flour and grain, of which the South is usually an exporter, the prices were not higher than at the North, measured in specie; but for those of which she is usually an importer the dearth of supply was greatly aggravated by the depreciation of paper. Nevertheless prices were very unequal even in home produce. Thus while flour was \$14.50 in Virginia, it was \$80 in Georgia. At the same time shirtings and sheetings were selling at 60 cents, equal to 24 cents in specie, or not more than the price in New York at that time. One cause of the higher price of flour in North Carolina and Georgia was the fact that the millers had depended on Virginia wheat, and the Government of that State prohibited its export, and the usual transfer of flour was checked. Salt, on the other hand, was at 26 cents paper, 10 cents specie. The occupation of the Kanawha by the forces under Gen. Loring, produced in October great activity to obtain supplies of salt sufficient for all the purposes of preserving the fall meats, from the Kanawha salines. These works, in the immediate neighborhood of Charleston, the county seat of Kanawha, produce annually an immense quantity of salt, and many hundred thousands of bushels were on hand at the time of the evacuation of Charleston by the Union troops. Long trains of wagons started for the salines from points as far distant as Staunton and Buchanan, and at one time three hundred wagons were awaiting at Gauley Ferry their turn to cross the river. When the Confederates first entered Charleston the salt was

offered for thirty-five cents the bushel; but under the stimulus of the rapid demand for the article from abroad, it very speedily rose to one dollar a bushel. A great demand also sprung up for the Louisiana rock salt.

These prices give some idea of the utter derangement of the currency under the continued issues of paper for which there seemed to be no remedy. Since August 1, the appropriations outstanding and estimates for expenses for 5 months up to Jan. 1, 1863, reached \$209,550,-487. To supply this amount there was no resource but the issue of paper money, which might be changed by the holders into 7 <sup>3</sup>/<sub>8</sub> bonds, receivable for dues, 6 per cent. certificates, payable on demand in currency, or 8 per cent. bonds, redeemable in from 10 to 30 years. The privilege of funding in the 8 per cent. bonds was to cease April 22, 1863, in order to hurry the conversion. After that date the holder would only get 7 per cent. bonds.

The following official notices indicate the uses of the several classes of paper:

TREASURY DEPARTMENT, RICHMOND, Aug. 1, 1862.

JOHN BOSTON, Esq., Depository, Savannah.

SIR: In answer to the inquiries of the 25th ult. you can say:

1. That the 7.30 interest notes will at any time be accepted in exchange for eight per cent. Confederate bonds, or for any debt due the Government, and that interest will be allowed as well as principal.
2. That I shall recommend that Congress pay annually the interest due on these notes to the respective holders thereof on the 1st of January.
3. That the six per cent. call certificates cannot be issued for these interest bearing notes, because such certificates are payable on demand in general Treasury notes of every denomination.
4. The 7.30 notes may be issued in exchange for the six per cent. call certificates. Such exchange effects directly what the holder of the certificates may do indirectly by calling for payment of his certificate in current notes, and then exchanging them for interest notes.
5. The purpose intended by the issue of interest bearing notes is to take them out of the general circulation. This is effected by the fact that a circulation of interest takes place at every transfer. It is not expected, therefore, that they will pass into the general deposits or circulation of the banks. In passing them from hand to hand, the interest grows each day by an easy calculation of two cents on each hundred dollar note, until the end of the year, when the interest will be paid up, if Congress shall accept my recommendation. With much respect,

C. G. MEMMINGER, Secretary of Treasury.

TREASURY DEPARTMENT, C. S. A., RICHMOND, }  
Nov. 6, 1862. }

DEAR SIR: Your letter of the 3d instant inquires whether "deposits made under the call loan can be funded on or before next April in the eight per cent. bonds." The conclusion of the department is, that the certificates of deposits issued under the six per cent. call loan entitle the holders to the same rights which they would have if they held the notes which had been deposited. It follows that certificates issued in exchange for the present issues of Treasury notes can be funded in eight per cent. bonds at any time on or before the 22d of April next, and up to that date this privilege will be the same, whether the certificates are issued before or after the 1st day of December next. Certificates which shall be taken for the deposit of new Treasury notes, to be issued after the first of December

part, will be fundable only in seven per cent. bonds. Respectfully,

C. G. MEMMINGER, Secretary of Treasury.

All these operations continued down to the close of the year, and the result was the following amount of debt, Jan. 1, 1863:

CONFEDERATE DEBT.

Class.	August 1, 1862.	Dec. 31, 1862.	Increase.
Bonds.....	\$41,577,940	\$38,886,480	\$47,809,160
Call certificates.....	23,734,400	66,488,970	23,704,570
Interest notes.....	22,799,900	121,472,000	98,672,100
Currency.....	188,244,185	269,157,692	105,913,507
Total debt.....	\$280,405,675	\$566,005,062	\$285,599,377

Thus the debt apparently increased more in the last five months than in the previous sixteen months of the war. One cause was the rise in prices, which reacted upon the Government, requiring more money for the same purpose. This increase is however less than it appears; since, of the interest Treasury notes, \$11,004,600 were still on hand. Also of the 8 per cent. bonds \$3,000,000 were on hand. Of the real increase of these bonds outstanding, \$7,000,000 were derived from the produce loan, and \$17,422,250 from funded notes. There was a large increase of interest bearing Treasury notes; and this increase added to the amount of bonds funded, makes nearly 20½ millions per month derived from that source. There remained, however, \$290,149,692 paper money outstanding at the close of the year, and the estimates required the sum of \$357,929,229 to carry on the Government to July, 1863. The disasters that must flow from a further issue of paper to that amount induced many of the States of the Confederacy to guarantee a war debt of the Confederate Government. The Secretary of the Treasury therefore proposed that; 1st, all the paper money issued prior to Dec. 1 should cease to be currency on the 1st of July, 1863, up to which time it may be funded in bonds; 2d, to impose a war tax on property that should yield \$48,000,000 per annum to meet the whole interest on the public debt; 3d, that the States' guarantee should be accepted for \$500,000,000, to be issued in a 6 per cent. stock.

The interest on the bonds being payable in paper suffers virtual decline through the rise in the prices of commodities. It was argued, therefore, that although by requiring the funding of the notes, the price of the bonds would decline in the market, their value to the holders would rise by reason of the better currency in which they get their interest. By the same means the expenses of the Government would be reduced, and the ultimate aggregate of the debt be decreased. The war tax proposed upon property, it was estimated, would give \$35,000,000, and an income tax of \$28,000,000 would give 63 millions, or 60 millions net, which would leave 12 millions to apply to so much of the principal of the debt annually.

The report of the Secretary of the Treasury, for the close of the year, gave the revenue and

expenditure from the 18th of February, 1862, when the Provisional Government terminated, to Dec. 31, 1862, being almost 10½ months. The results were as follows:

Customs.....	\$663,556	
War tax.....	16,664,518	
Miscellaneous.....	6,171,589	\$22,504,653
Bonds, 8 per cent.....	\$41,898,286	
Call certificates, 6 per cent.....	59,742,796	
Treasury notes, 7½ per cent.....	118,740,000	
Loans, February, 1861, 8 per cent.....	1,875,276	
Coin from Bank of Louisiana.....	2,590,799	
Currency.....	215,604,885	484,242,042
Total.....		\$457,546,699
Expenses.....	\$375,244,413	
Public debt paid.....	41,727,822	416,971,735
Balance.....		\$40,874,964

The war tax collected was large, but included a tax upon State bonds. In relation to which the Secretary remarks: "The very large amount of money invested in this form was included in the war tax of the last year, and the tax thereon was paid everywhere, except by those who raised the question in South Carolina. For the ensuing year the case would be different. If the same tax were laid by Congress, it is probable that the holders of State bonds would claim exemption under this decision, and Congress itself might be unwilling to reenact, in the same form, a law which had been declared unconstitutional by the coordinate branch of the Government, until that decision is reversed. The question is of such magnitude, and involves such great interests, that an appeal was taken. But this appeal cannot be decided until a Supreme Court shall be organized."

When the advance of the Federal armies into the Confederate States, both at the West and on the coast, commenced, the citizens were urged to burn all the cotton and tobacco. In Richmond, on the 26th of February, a convention of Representatives from a number of the States was held. Its object was thus stated by the chairman: "As cotton was king and tobacco vice-king, it was proposed to ascertain how far they could be made to subserve the cause of independence." Several propositions were made, viz., "that the crops should be voluntarily destroyed,—that the Government should purchase them and then destroy them if necessary." The result of all the proceedings on the subject was the passage of a law by Congress ordering all cotton to be destroyed "when it was about to fall into the hands of the enemy." The amount of cotton raised during the year was about one fourth of that of the previous year. More land was devoted to raising crops of grain, and the demands of the war reduced the number of cultivators. The British consul at Savannah returned to the Foreign Office the following estimate of the stock on hand at the close of the year:

According to reports made to the Comptroller General of this State by the tax collectors, the amount of land planted in cotton this year in Georgia is about 260,000 acres, yielding in round numbers 60,000 bales of cotton of 500 pounds each; ordinarily the production is 700,000 bales, requiring an area of about 3,000,000

acres. I am, of course, unable to report as accurately respecting the crops of other States, but the best information at my command strongly induces the belief that the entire crop gathered this year did not exceed 1,000,000 bales, proving the correctness of the approximate estimate transmitted to your lordship in my despatch, No. 14, of the 10th of May last.

The crop of 1861 was estimated at 4,500,000 bales. Deducting from the crops of 1861 and 1862 the quantity of cotton which has run the blockade, the amount destroyed to prevent capture by the Federalists, and the quantity used for home consumption, which, since the commencement of the war, has enormously increased, being now fully 500,000 bales per annum, it will leave in the South not more than 3,500,000 bales. The urgent necessity for the cultivation of breadstuffs since the Federal occupation of Kentucky and the best grain growing regions of Virginia, Tennessee and North Carolina, and the consequent strong popular opposition to the planting of cotton, together with other causes of hardly less importance, such as the entire want of bagging and rope necessary to put the cotton into merchantable condition, will tend hereafter to prevent any increase in the stock, possibly to diminish it; while, should the Federals succeed in making farther advances into the interior of the cotton growing States, the cultivation of that plant will be entirely abandoned, and the negroes removed to the mountainous districts, where breadstuffs alone can be raised.

E. MOLYNEUX.

The manufacturing industry of these States became more extensive than ever before, and in some branches more highly developed. The necessities of the Government and people, and the advancing prices, furnished a most powerful stimulant. Munitions of war and manufactures of cotton constituted the most important branches of this industry.

The high postage imposed by the Government greatly reduced the correspondence of the people, who were forbidden to transmit letters in any other manner than through the mails. The advance in the rates was made in order to enable the department to defray its expenses with its receipts. The effect, however, was to reduce the receipts and increase the demands of the department. The Government now had the choice either to reduce the amount of mail service exacted of the department, or to contribute to its expenses from the treasury. The President doubted the constitutionality of the latter measure and referred the subject to Congress. The Constitution says:

Congress shall have power to "establish post offices and post routes; but the expenses of the Post Office Department, after the 1st day of March, in the year of our Lord eighteenth hundred and sixty-three, shall be paid out of its own revenues."

Congress took into consideration the meaning of the word "expenses," and thus avoiding the constitutional question, recommended a loan to the department, for payment of the interest and principal of which its revenues should be pledged. The postage stamps were imported from England; so stringent was the blockade that some of the colors required in their manufacture could not be obtained within the Confederacy.

Martial law was proclaimed at Richmond, Norfolk, and other places during the year.

This was done by proclamations of the President, of which the following is the form stating that it is done by the authority of Congress:

By virtue of the power vested in me by law to declare the suspension of the privilege of the writ of *habeas corpus* in cities threatened with invasion, I, Jefferson Davis, President of the Confederate States of America, do proclaim that martial law is hereby extended over the City of Richmond and the adjoining and surrounding country to the distance of ten miles, and I do proclaim the suspension of all civil jurisdiction, with the exception of that of the Mayor of the City, and the suspension of the privilege of the writ of *habeas corpus* within the said city and surrounding country to the distance aforesaid.

The subject of conciliating the northwestern States by the free navigation of the Mississippi river and the opening of the markets of the South to the inhabitants of those States upon certain terms and conditions, was the first proposition suggested toward a settlement of the difficulties. This was considered in Congress. (See CONGRESS, CONFEDERATE.)

The relations of the Confederate States to foreign nations during the year are seen from the speeches and letters of their agents. Mr. Yancey, on his arrival at New Orleans on the 17th of March, made an address to the citizens, which is thus stated:

He remarked, on rising, that it was within ten days of a year since he left the country as the representative of the Confederate States to endeavor to procure the recognition of that independence for which his countrymen were gallantly contending. He should undoubtedly surprise his auditors when he told them that they had no friends in Europe; that they must depend for the accomplishment of the end for which they are striving upon themselves alone. And what he said of European feeling with regard to this Confederacy was equally true of its feeling toward the North, whose people, whose Government, and whose press, the statements and writings of whose public men and literary writers they believed to be altogether mendacious. The sentiment of Europe was anti-slavery, and that portion of public opinion which formed and was represented by the Government of England was abolition.

At the same time it is very well understood and believed that the pretexts upon which this war was inaugurated and is carried on against us were utterly false. They would never recognize our independence until our conquering swords hung dripping over the prostrate heads of the North. Their opinion of the character of the people of these States, and of the cause in which we are engaged, was derived altogether from Northern sources. They never see the journals and the periodicals of the South, and all the accounts with regard to us come to them filtered through those of the North. They believed that we are a brave and determined people, and that we are resolved upon obtaining our independence by the most unyielding devotion to the cause in which we are contending. But they would like to see the two Confederacies crippled by the war, and so would give aid to neither. He alluded to the erroneous and hostile opinions entertained in England with regard to the people of these States, which had been seditiously inculcated by the North, by whom we were habitually represented as cruel, lawless, and oppressive; that the owner had the liberty to treat his slaves without reference to the laws of society or nature, and that the slaves were bred as the English breed their Durham cattle, &c.

As to the blockade, he said that the nations of Europe would never raise it until it suited their interest. In his own private opinion, he believed that that necessity would occur by a very early day. He said

It was an error to say that "Cotton is king." It is not. It is a great and influential power in commerce, but not its dictator. He alluded to the dependence which British statesmen placed upon the probability of obtaining cotton from other sources than America, and showed that this, to any practical extent or purpose, was impossible, and that the idea was a fallacy. He thought, he said, that the blockade was a blessing to the Confederate States, for it was teaching—nay, compelling—us to depend upon ourselves and to do that for ourselves for which we have hitherto been depending upon others, and they our deadliest foes.

He then counselled a firm, united, and generous support of the Government which has just been inaugurated. The chosen and the choosers were both in the same boat. The storm was raging, the wind was howling, and the waves were beating upon our bark. We had placed them at the helm. They might commit errors, but all history teaches that when there is mutiny in the crew the bark must go down. He concluded by expressing the strongest confidence in the final success of the cause in which we are engaged, and at the close was greeted with the most enthusiastic cheers.

At this period of the year Mr. Mason was in London, Mr. Slidell in Paris, Mr. Rost in Spain, and Mr. Mann in Belgium, as representatives of the Confederate States. They continued to occupy these positions during the year, but were unsuccessful in obtaining a recognition of the Confederacy, or the adoption of any act which might change the existing relations.

The position of the Confederate Government at the close of the year was in some respects much stronger than at its commencement. The population of the States was brought to a more united action to sustain the cause. The determination manifested by the authorities of the States to sustain the Government, without agitating any vexatious questions as to the constitutionality of its measures, destroyed all opportunities for dissatisfied citizens to organize opposition. The declaration of the Federal Government that slavery was the cause of the war and that, to put an end to it, the cause must be utterly removed, placed the two Governments on the most extreme grounds of disagreement. President Davis appealed to the people in his Message to resist untidely this attempt to destroy their domestic institutions, and reminded them that the declarations of the States as to the cause of secession were now shown to be true by the acts of their enemies. The measures of the Federal Government were thus used to produce union and determination of purpose in the Southern mind to continue the struggle to the very last extremity. The address of Vice-President Stephens to the citizens of Crawfordsville, Ga., in Nov. 1862, presents an instance of the manner in which appeals were then made to the people:

If asked on our side, what is all this for? the reply from every breast is, that it is for home, for firesides, for our altars, for our birthrights, for property, for honor, for life—in a word, for everything for which freemen should live, and for which all deserving to be freemen should be willing, if need be, to die. In whatever trials and sacrifices this war may bring upon us, when the thought of "what is all this for," comes to the mind, recollect that it is, on our part, for everything most dear and sacred, and whatever reverses may

await us in a struggle for such objects, let the watchword of the last survivors be, "Never give it up." Let the world know, and history record the fact if such should be our unhappy fate, that though our country may be invaded, our land laid waste, our cities sacked, our property destroyed, the people of the South could die in defence of their rights, but they could never be conquered.

Exhaustion, however, was gradually doing its work. The territory of the Confederate States was constantly growing smaller by the occupation of their enemies, who never gave up an important place, where they once got a foothold. The number of able-bodied men was becoming fatally reduced, and when the conscription acts were exhausted, none would be found for recruits but old men and boys. The depreciation of the currency was approaching that verge beyond which it would be worthless. Well could the Vice-President exclaim, with the indomitable heroism of the Red Man at the stake, "Let the watchword of the last survivors be, Never give it up."

CONGREGATIONALISTS. During the year 1862, the number of Congregationalists in the United States has remained nearly stationary. The "Congregational Quarterly," which gives every year in its January number a very careful compilation of the statistics of the denomination, reported for January, 1862, a membership of 259,119, and for January, 1863, 261,474; increase during the year 2,355. The number of churches, in January, 1863, was 2,884; of ministers 2,643 (of whom 904 are pastors, 861 stated supplies, 215 not specified, and 663 not in service). Sabbath school scholars, 255,257.

The Congregationalist denomination in the United States is almost entirely confined to the Free States. Not one State association has yet been organized in any of the slaveholding States. A few churches, however, have been organized in Missouri, and a solitary church existed in Charleston, South Carolina. The church edifice of the Charleston congregation (the Circular Church) was destroyed by fire in the great conflagration at the close of 1861. Its pastor, Mr. Rice, was formerly settled in Connecticut, and at the time of the secession of the State was still a member of the Suffolk (Mass.) South Association. The great majority of the Congregational churches entertain the most thorough antislavery principles, and at the meetings of their State Associations strong resolutions were passed in favor of the emancipation measures of President Lincoln, declaring slavery to be the chief cause of the secession, and expressing the hope that the war would result in its extermination.

The Congregationalists of the United States, although far from being one of the most numerous American denominations, exceed most of the other denominations in ably conducted and influential theological periodicals. The "Independent," of New York, has the largest circulation of any religious newspaper of the world, while among the theological reviews the "Bibliotheca Sacra" and the "New Englander"

occupy a prominent place. During the year 1862, however, the Congregational press has been reduced—not less than four papers (the Lewiston "Maine Evangelist," Concord, N. H., "Congregational Journal," Chicago "Congregational Herald," and Oberlin, O., "Evangelist") having been suspended. There remained at the beginning of the year 1862, six weeklies, among which, next to the "Independent," the "Congregationalist," of Boston, had the largest circulation, four monthlies, and three quarterlies. In California the Congregationalists are united with the Old and New School Presbyterians in the issue of a weekly paper.

In Great Britain, the "Congregational Year-Book" for 1860, reports 1,840 churches in England, 719 in Wales, 101 in Scotland, 27 in Ireland; total in Great Britain 2,678. Of these not more than 759 made a report of their membership. The aggregate amounted to 96,754, being an average of more than 127 members to each church. The number of churches in the British colonies, in 1862, was as follows: The Canadas 87, other British North American provinces 16, British Columbia 1, Australasia 125, South Africa 9, Demerara 8—total 241. In connection with the London Missionary Society, which is chiefly under the control of the Congregationalists, there were 208 churches. The grand total of all the Congregational churches in the British dominions, in 1862, was 8,181. This number does not, however, include the village chapels, out stations, school houses, and other places in connection with the churches. The number of these is not reported, but is estimated at twice the number of the churches themselves, reaching a total of at least 10,000 places where the preaching is supplied by Congregationalist ministers and helpers.

The Congregationalists of England, in union with the other dissenting denominations, celebrated in 1862, with great solemnity, the bicentenary of the ejection of the two thousand non-conforming ministers from the English State Church in 1662. Two separate societies were formed with a view to encourage and direct the movements of the year—the "Bicentenary Committee," in connection with the Congregational Union, and the "United Bartholomew Committee," composed of persons of different denominations. The Bicentenary Committee of the Congregational Union collected a Memorial Fund, with a view to extend and perpetuate the remembrance of the day. This fund, of some £120,000 or more, has been raised for various objects, as the erection of chapels and schools, the liquidation of debts on chapels, the augmentation of the various funds connected with the Pastors' Retiring Fund, the British Missions, and the erection of a Memorial Hall.

The London Missionary Society had for the year 1861-'2, inclusive of some special contributions for India, China, etc., an income of £79,576. In connection with it were 170 Eu-

ropean missionaries, 40 missionary students, 800 native agents, catechists, etc., 208 churches, 23,192 communicants, 715 schools, 86,361 scholars. This summary does not include the native Christians of Madagascar, among whom the veteran missionary Ellis, together with other missionaries of the London Society, resumed during the past year their labors.

In France, the Evangelical Church of Lyons, which sustains six places of worship in the city of Lyons, and two in the country, is a Congregational body. Several other Congregational churches are united with Free Presbyterian churches into the "Union of Evangelical Churches in France," which was formed in 1849, and had in 1862 about 80 places of worship, and 2,000 members. In Italy, the Free Evangelical churches hold independent principles. In Switzerland, the Free churches of Vaud, now 42 in number, are Congregationalist; and small Independent churches have also been formed in twelve places in other cantons.

CONGRESS, CONFEDERATE. The sessions of the Provisional Congress, which commenced on the 18th of November, 1861, were continued until the 15th of February, 1862, when its term of existence expired. These sessions were almost entirely held in secret, and no reports have been made public. It was a body elected by the State Conventions and Legislatures, and more truly and unanimously a representative of them than of the people. It was created for the great purpose of combining the States which had resolved to withdraw from the Federal Union, and to prepare the way for the organization of a separate and independent Government. These duties were boldly and resolutely performed.

On the 18th of February the Government commenced its existence under the "Permanent Constitution." On that day at noon the Confederate Congress assembled at Richmond, and the Vice-President elect, Alexander H. Stephens, of Georgia, took the chair in the Senate, and under the authority of the Constitution formally opened the session of that body. He caused to be read the last clause of the Constitution and the act of the Provisional Congress putting in operation the permanent Government of the Confederate States, and the act supplemental to the same. All the slaveholding States were represented, except Delaware and Maryland.\*

\* The following is a list of the members of both houses:

SENATE.

Alabama.—Clement C. Clay, Wm. L. Yancey.  
 Florida.—J. M. Baker, A. E. Maxwell.  
 Kentucky.—Wm. E. Simms, H. C. Burnett.  
 Mississippi.—James Phelan, Albert G. Brown.  
 North Carolina.—George Davis, Wm. S. Dortch.  
 Tennessee.—Gustavus C. Henry, Landon C. Haynes.  
 Arkansas.—Robert W. Johnson, C. B. Mitchell.  
 Georgia.—John W. Lewis, B. H. Hill.  
 Louisiana.—Thos. J. Semmes, Edward Sparrow.  
 Missouri.—John B. Clark, Robert L. Y. Peyton.  
 South Carolina.—Robert W. Barnwell, James L. Orr.  
 Texas.—Lewis T. Wigfall, Wm. S. Oldham.  
 Virginia.—Wm. B. Preston, E. M. T. Hunter.

Nineteen Senators being present, the oath to support the Constitution was then administered. R. M. T. Hunter, of Virginia, was chosen president *pro tem.* and the Vice-President retired. James H. Nash, of South Carolina, was chosen secretary, and James Page, of North Carolina, doorkeeper.

The House of Representatives assembled at the same hour, and were called to order by Howell Cobb, president of the late Provisional Congress. The act of that Congress was then read, whereby it was made his duty to preside at the organization of the House of Representatives of the Permanent Congress. A quorum being present, the following oath was administered to the members by States: "You, and each of you, do solemnly swear, that you will support the Constitution of the Confederate States of America. So help you God." Mr. Thomas S. Bocock, of Virginia, being the only person nominated, was then elected Speaker. He was the candidate for the same position at the first session of the Thirty-sixth Federal Congress. Mr. Bocock, on taking the chair, addressed the House as follows:

GENTLEMEN OF THE HOUSE OF REPRESENTATIVES: I return to you my sincere thanks for the honor you have done me in selecting me to preside over your deliberations during this the first Congress under our permanent constitution. And I desire to say that it will be my one great aim, in discharging the duties of this office, so to conduct myself as to show to you and to the world that your confidence has not been altogether misplaced. I may be permitted to say that I have a

firm determination, so far as I may be able, to maintain the dignity and preserve the decorum of this body; to administer its rules with firmness and courtesy, and to conduct its business with the strictest impartiality. If such a determination, united with a sincere desire to see our legislation take such shape as will best tend to secure the independence, maintain the honor, and advance the welfare of this entire Confederacy—if this could command success—I am sure I might expect to succeed. But other qualifications are requisite, about which it is not for me to promise. If in anything I may fall short, I trust that the same kind partiality which has called me to this position will throw the mantle of charity over my defects, and will give me, in every time of trial, that kind coöperation and generous support which my deficiencies may require. The unanimity with which you have made this election is a happy augury of the spirit with which your proceedings will be governed. This is no time for resentments, no time for jealousies or heartburnings. Influenced by a great common purpose, sharing together the same rich hope, and united by a common destiny, let us hush every murmur of discontent, and banish every feeling of personal grief. Here let us know no man save as a co-laborer in the same great cause, sustaining those whom circumstances may designate to go forward; seeking nothing for the sake merely of personal gratification, but willing rather to yield everything for the public good—"in honor preferring one another." That some of you, influenced by momentary impulse, should grow restive under the enforcement of those rules which you may make for your own government would be a matter neither of surprise nor of complaint. But he will prove himself either a weak or a bad man who, on reflection, fails to call back his wayward spirit, and subject it to necessary restraint. Submission to constituted authority is the primary necessity in all communities, and self-control is the chief lesson of individual life. In the light of passing events we can measure the height and the depth of the excellence intended to be conveyed, when it is said, "Better is he who ruleth his own spirit than he who taketh a city." The gaze of the world is fixed upon us. Nations look on, curious to see how this new system of government will move off, and what manner of men have been chosen to guide its earliest movements. It is, indeed, a new system; for though coinciding in many particulars with that under which we lived so long, it yet differs from it in many essential particulars. When the Constitution of 1787 was put in operation the War of the Revolution had been successfully closed. Peace prevailed throughout the whole land, and hallowed all its borders. The industrial operations of the country, long held back, now bounded forward and expanded with all the vigor and rankness of tropical vegetation beneath the influence of a midsummer sun. The trial which that constitution had to encounter in its earliest, as well as in its more matured existence, was simply one engendered by a conflict of these interests. The question was whether it could give protection to all these interests without becoming the partisan of one and the oppressor of another; or, in fact, whether it had the sustaining power to preserve its integrity against the influence of interest wielded by ambition. We have seen the result. The case with our constitution is very different. It is put into operation in time of war, and its first movements are disturbed by the shock of battle. Its trial is one created by the urgencies of this contest. The question to be decided is, whether, without injury to its own integrity, it can supply the machinery and afford the means requisite to conduct this war to that successful conclusion which the people, in their heart of hearts, have resolved on, and which, I trust, has been decreed in that higher court, from whose decisions there is no appeal. The solution of this question is in the bosom of the future. But our system can never perish out like that to which I have alluded. When ambition and interest seized upon that, and destroyed its integrity, they were not allowed to appropriate the rule altogether to themselves. Fanaticism

## HOUSE OF REPRESENTATIVES.

*Alabama.*—E. L. Dargan, W. P. Chilton, James E. Pugh, Jabez M. L. Curry, Wm. E. Smith, John P. Rawles, Thomas J. Foster, David Clouston, L. F. Lyon.

*Arkansas.*—Felix J. Batson, G. D. Royster, A. H. Garland, T. B. Hanley.

*Florida.*—James B. Dorkins, E. B. Hilton.

*North Carolina.*—Wm. H. N. Smith, Robert Bridges, Owen R. Keenan, J. G. McDowell, Thos. S. Ashe, Archibald Arrington, Robert McLean, William Lander, R. C. Galther, A. S. Davidson.

*South Carolina.*—Wm. W. Boyce, Wm. P. Miles, M. L. Bonham, John McQueen, L. M. Adger, James Farran.

*Georgia.*—A. H. Keenan, Hines Holt, A. R. Wright, Julien Hartridge, L. J. Gartrell, Wm. W. Clark, Robert P. Trippe, D. W. Lewis, J. C. Monnalum, Hardy Strickland.

*Kentucky.*—Wills B. Machen, John W. Crockett, H. E. Ead, Geo. W. Ewing, Jas. S. Crisman, Geo. P. Hodges, H. W. Bruce, S. S. Scott, E. M. Bruce, R. J. Breckinridge, Jr., John M. Elliott.

*Louisiana.*—Duncan F. Kenner, Charles Villiers, John Perkins, Jr., Charles M. Conrad, Henry Marshall, Lucien Dupose.

*Mississippi.*—John J. McRae, J. W. Clapp, Reuben Davis, Israel Welsh, H. C. Chambers, Otho R. Singleton, E. Barksdale.

*Missouri.\**—Wm. H. Cooke, Thomas A. Harris, Casper W. Bell, A. H. Conrow, George G. Vest, Thomas W. Freeman, Samuel Hyert.

*Tennessee.*—A. G. Watkins, D. M. Currin, J. D. C. Atkins, H. E. Foster, Thomas Menace, George W. Jones, Meredith P. Gentry, William G. Swann, W. H. Tibbe, N. S. Gardner, J. T. Hefskell.

*Texas.*—John A. Wilcox, P. W. Gregg, C. C. Herbert, W. B. Wright, M. P. Graham, S. R. F. Bexton.

*Virginia.*—John R. Chambliss, M. E. H. Garnett, James Lyons, — Collier, Thomas S. Bocock, John Goode, Jr., James P. Holcomb, D. C. DeJarnette, William Smith, A. R. Beteler, John B. Baldwin, Waller R. Staples, Walter Preston. Vacancy vice A. G. Jenkins, Robert Johnson, Charles W. Russell.

\* Missouri, under the apportionment, is entitled to thirteen members. The State has not been districted, and the above members—to the Provisional Congress—hold over.

† Taken the oath of allegiance to the United States, and not present.



came forward and demanded to be received as a participant of power with them, and it claimed not in vain. Beneath the sway of this unholy triumvirate justice was forgotten, intolerance was established, private morals were ruined, and public virtue perished. All feeling of constitutional restraint passed away, and all sense of the obligation of an oath was forever lost. The whole machinery of government degenerated into the absolute rule of a corrupt numerical majority. Already the weaker section was marked out for destruction by the stronger, and then came disruption and overthrow. Since then tyranny the most absolute, and perjury the most vile, have destroyed the last vestige of soundness in the whole system. Our new system is designed to avoid the errors of the old. Certainly it is founded in a different system of political philosophy, and is sustained by a peculiar and more conservative state of society. It has elements of strength and long life. But at the threshold lies the question I have already stated. Can it legitimately afford the means to carry the war to a successful conclusion? If not, it must perish; but a successful result must be achieved. But it must be destroyed, not by the hand of violence, or by the taint of perjury. It must go out peacefully and in pursuance of its own provisions. Better submit to momentary inconvenience than to injure representative honor or violate public faith. In the whole book of expedients there is no place for falsehood and perjury. Let us, on the contrary, assiduously cultivate the feeling of respect for constitutional limitation, and a secret reverence for the sanction of an oath. Seeing, therefore, gentlemen of the House of Representatives, that we are custodians of the nation's life and the guardians of the Constitution's integrity, what manner of men should we be? How cool, how considerate, how earnest, how inflexible, how true. Having no prospect in the future, save through the success of our cause, how regardless should we be of all selfish views and plans of personal advancement. Selected by the people to take care of the State in this time of difficulty and of trial, how we ought to dedicate ourselves in heart, mind, soul, and energy to the public service. Neither history has recorded, nor song depicted, nor fable shadowed forth higher instances of self-devotion than ought to be shown in the conduct of this Congress. It is not allowed us to pursue a course of obscure mediocrity. We inaugurate a Government, we conduct a revolution. We must live, live forever in the memory of man, either for praise or for blame. If we prove equal to the crisis in which we are placed, we shall win imperishable honor. But if, on the contrary, we show ourselves incompetent to the discharge of our duty, we shall sink beneath the contempt of mankind. Truly our position is one of great import. Our gallant army now holds, as it deserves, the first place in the thoughts and affections of our people. But of scarcely less importance, in the estimation of all, is the legislative authority, which initiates the civil policy of the Confederacy, and which sustains and upholds that army itself. And when the latter shall have accomplished its holy mission by driving the invader from the soil which he desecrates and pollutes; and when the hearts of a grateful and free people, more generous than a Roman Senate, shall, for this service decree to it one lifelong oration; if true to ourselves, and competent to our duty, this Congress will be united in the triumphal honors. And if this Constitution be destined to go forward, as we hope and believe it will, to a distant future, gaining new strength from trial, and winning new triumphs from time, giving protection and peace to successive generations of happy and enlightened people; as the gray haired sires and venerated patriarchs of ages now remote shall seek to inspire the courage and fire the hearts of the ingenious youth of their day by recounting the heroic deeds of the army which achieved our independence; let the lesson be extended and enlarged by our enabling them to tell also of the self-sacrificing patriotism and enlarged statesmanship of the Congress which inaugurated the Permanent Constitution of the Southern Confederacy. Again I thank you.

Although all important measures introduced at this and the subsequent sessions of Congress were discussed with closed doors, and no reports have ever been made public of the speeches or votes, yet some measures were incidentally discussed in open session, which furnish a view of the opinions of members. On the next day the Senate came to the House, and the votes for President were counted. The form of proceeding was that adopted under the Federal Constitution. The votes were as follows:

Total number of States voting.....	11
Number of electoral votes cast.....	109
For Jefferson Davis, of Mississippi, for President.	109
For Alexander H. Stephens, of Georgia, for Vice-President.....	109

The number of votes cast by the States was as follows:

Alabama.....	11	North Carolina.....	12
Arkansas.....	6	South Carolina.....	8
Florida.....	4	Tennessee.....	12
Georgia.....	12	Texas.....	8
Louisiana.....	8	Virginia.....	12
Mississippi.....	9		
Total.....	109		

On the 22d of February the Inaugural Address was delivered, and on the 25th a Message was sent to Congress by the President. (*See PUBLIC DOCUMENTS.*)

The following resolution was offered by Mr. Foote, of Tennessee, in the House on the 20th:

*Resolved*, That whatever propriety there may have been in the original adoption of what is known as the defensive policy in connection with the prosecution of the pending war for Southern independence, recent events have already demonstrated the expediency of abandoning that policy henceforth and forever, and that it will be the duty of the Government of the Confederate States to impart all possible activity to our military forces everywhere, and to assail the forces of the enemy wherever they are to be found, whether upon the land or water, with a view to obtain the most ample indemnity for the past, and the most complete security for the future.

Mr. Jenkins, of Virginia, hoped that the House would not concur in the resolution without discussion, impeaching as it did the Administration. Gentlemen may argue as if the policy of the Government could be changed by the mere substitution of one word for another, but the change of policy proposed would necessitate the increase of our army to double its present size.

Mr. Foote earnestly advocated the resolution, which expressed, he was sure, the universal conviction of the country, and which he hoped would meet a favorable response from this House. He denounced the defensive policy, which all history would show was not the policy which a people in revolution should adopt. President Davis did not need the vindication of the gentleman from Virginia, for he had high authority for saying here that the President was opposed to the defensive policy which "somebody"—he could not say who—had imposed upon the country. Judge Harris, of Mississippi, an intimate friend of the President, had authorized him (the speaker) to declare that the latter had no hand and no parti-

icipation, however remote, in stopping the onward movement of our armies; on the contrary, the President had allowed to the generals in the field the most liberal discretion. They alone are responsible for the deplorable non-action of our forces. The speaker then pointed out the advantages which, to his mind, might have occurred to us, had a vigorous onward movement been adopted immediately after the battle of Manassas. And of such a movement he was yet in favor; he desired that the Yankees shall be made to pay the whole expenses of this war, that the commercial magnates of New York, Boston, and Philadelphia be made to unlock their strong boxes, and to indemnify the South for losses which they had imposed upon her. He desired, above all things, to drive the enemy beyond our borders. All this he would have, and nothing less. He desired to show to the world, that which the adoption of this resolution would express, that the Southern people, far from being disheartened by reverses, are invigorated in their determination to achieve their independence. Southern freedom, he contended, could have been achieved six months ago had we pushed boldly forward. Had we passed into Maryland—heroic Maryland—rescued Baltimore and Annapolis, and cut off the railroad communication with the North, that independence which we must now purchase with a vast expenditure of blood and treasure, could have been secured to us at less than one fourth of what the war has already cost us.

Mr. Jenkins said, while listening to the gentleman's eloquent illustration of the *art militaire*, there came across his mind the vision of a by-gone scene. He referred to that scene related in ancient history, when a philosopher of classic renown endeavored to prove to Hannibal the error of his system of warfare. No doubt he did it quite as eloquently and as plausibly as the philosopher from Tennessee had discoursed here to-day. When the philosopher had departed from the presence of Hannibal, a friend asked him what he thought of his instructor. The reply, said the speaker, is doubtless familiar to all here. He had too much respect to apply it directly to his friend from Tennessee, whom the quotation fitted as nicely as a wedding garment.

Mr. Foote said he remembered well the quotation alluded to, and in reply to the gentleman from Virginia, would demand to know whether he intended to apply it personally to him. If so, he should make a special issue with the gentleman upon it.

Mr. Jenkins said he did not remember the entire quotation, but if it contained aught which could be deemed disrespectful, he here disclaimed any intention of applying it to the gentleman from Tennessee.

Mr. Foote accepted the disclaimer, and said that as the gentleman's memory was so defective, he would recite Hannibal's reply, which was that the philosopher "was the greatest fool he had ever seen."

Mr. Boyce, of South Carolina, said: "He had thought that we should proceed with all possible energy. We should have aimed at an offensive warfare. All the slave States should be included. In his opinion the war between the North and the South might last a long time, and that hostilities would exist forever. We cannot afford to give up one inch of our Southern soil. The North now exceeds us to the number of eighteen or twenty millions of white people. We should have pursued, from the very first, more of an aggressive policy, which would have given a position to the Southern States; it would have encouraged our friends and discouraged our enemies, and such a policy had been indicated by our distinguished President from Mississippi, when on his way to be inaugurated as President of the Provisional Government—that we should wage war on the enemy's own ground. Mr. L. P. Walker, the former Secretary of War, had said at an early day that the flag of the South should float shortly over the Capitol at Washington. He, the speaker, had thought the expression unwise at that time. We should have talked peace and acted war; used peaceful terms, but prepared for active war. Audacity! audacity! audacity! is the key to success. Make no show of fear; prosecute the war with great vigor. Talk of risk—have we not risked a revolution? and shall we see it fail? We should have pursued an aggressive policy from the very first. The enemy at that time were unprepared; they had but 75,000 men, and most of them were holiday soldiers, and came South as to a sort of Fourth of July celebration. The genius of our policy should then have been action."

Mr. Machen, of Kentucky, said: "I came from a land which is now resonant with the drum and fife of Yankeedom. Still I am not in favor of adopting a new policy or of having Congress dictate what shall be the disposition of our forces with regard to the enemy. Congress should not usurp the military power."

Mr. Foote, rising, said: "I want to know if a simple proposition is usurpation. If simply to express an opinion is to be styled and considered usurpation, I want to go home."

The resolution was laid on the table.

In the Senate, the Committee on Military Affairs reported a bill to indemnify the owners of cotton, tobacco, military and naval stores, or other property of any kind whatever which might be of use to the enemy, that should be destroyed to prevent its capture.

The bill was finally passed in the following form:

Be it enacted by the Congress of the Confederate States of America, That it shall be the duty of all military commanders in the service of the Confederate States to destroy all cotton, tobacco, or other property, that may be useful to the enemy, if the same cannot safely be removed, whenever, in their judgment, the said cotton, tobacco, and other property is about to fall into the hands of the enemy.

This cuts off all compensation to owners. It

was estimated that the amount of cotton liable to destruction would not amount to much more than 5 per cent. of the entire crop. The same was the case with tobacco.

The following joint resolutions were presented in the House by Mr. Rowles of Alabama, on the 24th of February, and unanimously adopted:

*Whereas*, The United States are waging war against the Confederate States, with the avowed purpose of compelling the latter to reunite with them under the same constitution and government; and whereas, the waging of war with such an object is in direct opposition to the sound republican maxim that "all government rests upon the consent of the governed," and can only tend to consolidation in the general government and the consequent destruction of the rights of the States; and whereas, this result being attained, the two sections can only exist together in the relation of the oppressor and the oppressed, because of the great preponderance of power in the Northern section, coupled with dissimilarity of interests; and whereas, we, the representatives of the people of the Confederate States, in Congress assembled, may be presumed to know the sentiments of said people, having just been elected by them; therefore, be it

*Resolved*, That this Congress do solemnly declare and publish to the world that it is the unalterable determination of the people of the Confederate States (in humble reliance upon Almighty God) to suffer all the calamities of the most protracted war, but that they will never, on any terms, politically affiliate with a people who are guilty of an invasion of their soil and the butchery of their citizens.

The compensation of members of Congress was fixed, by an act, at \$3,000 per year, and mileage at the rate of 20 cents per mile.

The following rates of compensation were also adopted: Secretary of the Senate, \$2,500; Assistant do., \$2,000; two clerks, each \$1,500; sergeant-at-arms of Senate, \$2,000; doorkeeper, \$1,500.

In the House, Mr. Foote, from the Committee on Foreign Affairs, reported that they had had under consideration a bill to send commissioners to represent the Confederate States in the Industrial Exhibition to be held at London in the year 1862. They reported back the same, and asked to be discharged from the further consideration of the subject, and that the bill lie on the table.

On the 27th of February a resolution was unanimously adopted in the Senate, declaring that the Confederate Government would entertain no peace propositions excluding any portion of the soil of any of the Confederate States, and that the war should be continued until the enemy had been expelled entirely from the Confederacy.

In the House, on the 8d of March, a resolution was passed advising planters to withdraw from the cultivation of cotton and tobacco, and devote their energies to raising provisions, cattle, hogs, sheep, &c.

On the 4th, a Message was sent to Congress by President Davis, in which he stated that he had suspended Gens. Floyd and Pillow from their commands until they could give a more satisfactory account of the action at Fort Donelson. He said that neither of these generals says that reinforcements were asked for, nor do they

show that the position could not have been evacuated and the whole army saved as well as a part of it. Neither is it shown by what authority two senior generals abandoned their responsibility by transferring their command to junior officers. Subsequently, on the request of the Legislature of Virginia, Gen. Floyd was reinstated. On the same day a vote of thanks to Capt. Buchanan and the officers and crew of the Merrimac for their gallantry in the action in Hampton Roads, was passed.

On the 12th of March the Senate took up the resolution of the House, proposing to advise the planters of the Confederacy to abstain from raising cotton and tobacco this year, and to devote themselves exclusively to the production of grain and provisions.

Mr. Brown, of Mississippi, moved to lay this resolution on the table, for the purpose of allowing him to introduce a bill to curtail the cotton crop for the year 1862.

The measure proposed by Mr. Brown provided that no planter or head of a family should sow more cotton seed than would produce three bales of the staple for himself, and one bale for each of the hands employed in the culture during the year 1862; and, in case of exceeding this number, the penalty shall be \$40 fine for each bale; and, further, that the planter or head of family should be required to swear to the exact number of bales raised during the year, and to be treated as a perjurer if he swears falsely.

Mr. Brown said that the resolution of the House was not of the slightest use in the world. If anything, it would have a bad effect, inasmuch as it virtually offered a premium for treachery. Patriotic citizens would not plant any cotton, with or without the resolution; but the large class of grasping Shylocks, bent on gain and personal aggrandizement, would pay no attention to the advice of Congress; and for these Mr. Brown would have a compulsory law. He conceived that a large cotton crop this year would be ruinous to us, since the labor of plantations would be withdrawn from the production of provisions absolutely needful for the support of our armies and our people. He thought that if there was evil in the cotton crop we should strike at the root, or take it by the throat.

Mr. Orr, of South Carolina, said the gentleman was mistaken as to the number of unpatriotic planters. The class, in his judgment, was very small.

Mr. Clay, of Alabama, suggested that the measure proposed by the gentleman was unconstitutional. The forfeiture of the \$40 per bale was an indirect mode of raising revenue, and all bills for this purpose, under the constitution, must be originated in the House of Representatives.

Mr. Wigfall, of Texas, said that if any power was laid down clearly in the constitution of the old government and in the new, it was the definition of the powers of Congress regarding the

punishment of the crimes of treason, of piracy, and of felony on the high seas. Here it is clearly laid down that Congress cannot create crime. Apart from the unconstitutionality of the proposition, Mr. Wigfall objected to the measure proposed for other reasons. He was not sure that it was good policy for us to neglect raising cotton. Unless we continue to raise the staple in abundance, England would foster its cultivation, and after the war it would be difficult for us to monopolize the markets of the world. If we raised no cotton in 1862 it would keep the price up so high that it would pay the other nations of the world to invest largely. This is the policy most desired by English statesmen, and it is that which has prevented the raising of the blockade.

Mr. Brown could not understand why a bill to punish people for not burning cotton likely to fall into the hands of the enemy was not unconstitutional when one to punish the production of the article was. He conceived that in time of war the powers of Congress were augmented, and that it was quite different from peace.

Mr. Clay replied that persons allowing cotton to fall into the hands of the enemy were guilty of treason: for it is giving aid and comfort to the foe, and that is treason, and treason is one of the crimes defined by the constitution. Mr. Clay denied, also, that the constitution was so elastic that it expanded its powers in war and contracted them in peace. The constitution was the same always.

Mr. Barnwell, of South Carolina, was not prepared to abandon the cultivation of cotton under any circumstances, though he admitted a great deal of labor should be bestowed upon the production of supplies, especially at this juncture. On the cultivation of cotton and increase of supplies for market depend not only our sources of wealth, but our importance and consequence, and weight with foreign nations. All our interests appeal to us never to give it up. We must raise it, hold it, and fight for it. We must let the world know that we have it, and that we will sell it cheap, and that we will fight to keep it from our enemy and to protect it. We should not only protect ourselves against our enemy, we should not give our sole strength to the production of articles of subsistence, but we must keep up the cultivation of that which gives us position in the world as a nation, and by which we will control the world. We must have a monopoly of all the markets. We begin to find out that we have not a monopoly, that cotton can be produced elsewhere. Plentiful crops, low prices, and superiority of the article will alone achieve our ends. These at the end of the war will give us our former preponderance. The proposition of the gentleman from Mississippi (Mr. Brown) excited his unfeigned astonishment. He had conceived it to be a long settled principle that this Government, or one with similar powers, could not create a crime under the common law.

He protested warmly against this the grossest assumption of authority he had ever witnessed.

Mr. Semmes, of Louisiana, would like the vote direct on the resolution, and for this purpose asked that the motion to lay on the table be withdrawn.

This was done and the resolution was put upon its passage.

Mr. Hunter, of Virginia, objected to the bill of Mr. Brown, for two reasons: First, he did not wish to tax the patriotism of the planters; and, secondly, the want of power of Congress to interfere with the internal affairs of any of the States. The policy which diminishes the supply of cotton will hold out no inducements for England to break up the blockade. By keeping cotton scarce and high, its production is stimulated in other countries; India, for instance. If we are denied admission to the markets for several years, and the price is kept to 25 or to 30 cents, see what powerful incentives are given to its production elsewhere. To bring about this state of things and to become the main producer is the secret of all British legislation. This stimulates the planters in their tropical colonies to raise cotton under any disadvantage; otherwise their interests as manufacturers would have compelled them to raise the blockade. Cotton is a source of power and influence only so long as we can raise and keep it in vast quantities at low prices. As to the constitutionality of the bill proposed by Mr. Brown, Mr. Hunter said the Confederate States Government had not the least right to go to any of the States and say how much cotton should be produced. The sovereignty of the States themselves hardly dare do this, much less the delegated power of the Confederacy. If he believed that Congress would pass any such act, or the Government possessed any such power, he would pronounce it a most notorious despotism, worse even than that from which we have just escaped.

Mr. Brown urged that the main object of the enemy being to pass down to the Mississippi Valley and seize our cotton, we should prevent any more being there than could be helped. The idea that cotton could be raised in India was, to use a homely phrase, played out. He was in favor of burning all the cotton we now had, and planting no more until the world was disposed to do us justice. Then we could test the question of cotton raising in India, with no fears as to the result. Regardless of every power on earth, let us act for ourselves and strike blows for our own superiority.

Mr. Semmes, of Louisiana, had long since abandoned the idea that cotton is king. He had arrived at the conclusion that this was a mistake. Nations would violate the laws of nations to supply themselves with cotton, and interest was the ruling principle of the world. We have tested the powers of King Cotton, and have found him to be wanting. We must now abandon all dependence on foreign intervention. The English never will interfere, be-

cause it is not for their interest. Rather than make war with the United States she would convert her Government into an eleemosynary for the maintenance of her hordes of starving operatives. She would do this because it would be cheaper, and because the darling projects of her statesmen could be fostered and cotton be produced in her colonies. He voted for the resolution for the reason that warning should be given the people to prepare for the continuance of a lengthy war, and that produce must be raised for our subsistence.

Mr. Wigfall acknowledged that cotton was not king, but merely the badge of royalty to him who possessed it. This was the reason England abstained from raising our blockade. She wished to see us destroyed as cotton producers, so that she could become raiser as well as spinner, and thus command the world. She abandoned her own West Indies to abolition in order to foster cotton-raising in India.

The resolution was finally put to vote on its adoption, and lost, as follows:

YEAS.—Messrs. Clay, Clark, Davis, Dorch, Henry, Mitchell, Sparrow, and Semmes—8.

NAYS.—Messrs. Barnwell, Baker, Horner, Hill, Hunter, Johnston, Oldham, Pheian, Peyton, Preston, and Wigfall—11.

The surrender of Roanoke Island was investigated by a committee of the House, who presented a voluminous report concluding as follows: "Whatever blame or responsibility is justly attributable to any one for the defeat of our troops at Roanoke Island, on the 8th of February last, should attach to Maj.-Gen. Huger and Mr. Benjamin, the late Secretary of War."

In the Senate a resolution was offered to appropriate a sum of money to pay the persons engaged in taking the census of 1860 in the State of Louisiana, for which services the United States had not paid.

Mr. Semmes, of Louisiana, who urged the matter, proposed to disburse the balance (about \$8,000) from moneys seized by the State of Louisiana and transferred to the Confederate States Government, a part of which was originally intended by the United States Government for that purpose.

Mr. Burnett, of Kentucky, opposed the bill on the ground that it would open the door to any number of claims (perhaps amounting to millions of dollars) of a similar nature, all of which would most properly be attended to after a treaty of peace.

Mr. Semmes made the following exhibit of money transferred to the Confederate States Government by the several States named:

North Carolina.....	\$26,200 in bullion.
" " .....	1,175 in customs.
Louisiana .....	457,859 in bullion.
" " .....	147,875 in customs.
Alabama .....	18,781 in customs.
Georgia .....	23,763 in bullion.
" (Savannah).....	3,483 in customs.

The resolution was rejected.

The sum of \$4,275,000 was appropriated for

the use of the Navy Department, of which \$2,100,000 was for the equipment and repair of vessels, for ordnance and ordnance stores, and for the purchase and building of steamers, and \$500,000 for gunboats for coast defences.

Propositions were considered for a new flag and a new seal, which finally failed to pass.

A resolution was offered in the House to request the Executive to recall at once the Commissioners sent to Great Britain, and to abandon all further attempts to conciliate the favor and secure the recognition of that Government. It failed to pass. Another bill was passed in the House to repeal the tariff and throw open the Confederate ports to the commerce of the world except the United States. It failed in the other House.

The following resolutions were offered in the House on the report of the battle on the first day at Shiloh:

*Resolved*, That Congress have learned, with feelings of deep joy and gratitude to the Divine Ruler of nations, the news of the recent glorious victory of our arms in Tennessee.

*Resolved*, That the death of Gen. Albert Sidney Johnston, the commander of our forces, while leading his troops to victory, cannot but temper our exultation with a shade of sadness at the loss of so able, skillful, and gallant an officer.

*Resolved*, That, in respect to the memory of Gen. Johnston—the Senate concurring—Congress do now adjourn until twelve o'clock to-morrow.

In the Senate on the same day Mr. Haynes, of Tennessee, moved that the resolutions touching the victory near Corinth, and lamenting the death of Albert Sidney Johnston, be taken up, so that he could offer resolutions in lieu. Resolutions were then presented by the Senator, expressive of the joy of Congress on hearing of the great victory of our army in Tennessee, paying a glowing tribute of respect to the memory of the commander-in-chief, and conveying the thanks of Congress to Gen. Beauregard and the officers under his command for their services on that memorable day.

Mr. Haynes stated that he was one of the Tennessee delegation who requested the President to transfer Gen. Johnston's command to some other officer after the retreat from Nashville. Subsequent information had caused him to alter his opinion, and he therefore felt it his duty to offer the resolutions named.

Mr. Yancey, of Alabama, moved that the resolutions be so amended as to designate the place of the battle as indicated by Gen. Beauregard—viz.: the battle field of Shiloh. He moved, also, that the resolutions be so amended as to tender the thanks of Congress to Gen. Beauregard and the surviving officers and soldiers for their gallantry and skill on that memorable field.

On a subsequent day Mr. Barnwell, from the Finance Committee, reported back favorably the bill to authorize the issuance of Treasury notes of a denomination less than five dollars. As before explained, the bill authorizes the utterance of one, two, three, and four-dollar

notes, and notes for the fractions of these sums, provided the whole amount issued does not exceed five millions of dollars in the aggregate.

Mr. Brown, of Mississippi, offered an amendment to the last clause of the bill to increase the clerical force of the Treasury Department, requiring the Secretary of the Treasury to give preference to applicants for clerkships under the bill to those who have served in the army, and have been discharged on account of physical inability, or from wounds received in battle.

Mr. Barnwell, of South Carolina, opposed the amendment because he looked upon it as an indirect mode of pensioning, disabled soldiers. He was of the opinion that other modes could be provided for taking care of this class of the population.

The amendment was adopted and the bill was passed.

The joint resolution passed by the House, voting the thanks of Congress to the patriotic women of the country for their voluntary contributions to the army, and in aid of the cause in every conceivable way, was taken up and unanimously passed.

Mr. Sparrow offered a resolution authorizing the Senate to furnish the Senators from North Carolina with copies of all reports, &c., received by the Senate from the President, in relation to the Roanoke Island affair, for the use of the Convention of North Carolina—upon the consideration of which the Senate went into secret session.

The conscription act passed on the 9th of April and was approved on the 16th. (*See CONFEDERATE STATES.*) A bill was also passed to organize a battalion of sharpshooters, and another appropriating \$1,500,000 to construct a railroad between Galveston and New Orleans.

On the 21st of April Congress adjourned to meet on the third Monday of August. Its important business was entirely transacted in secret session.

On the 18th of August the second session of the Confederate Congress under the Permanent Constitution commenced. A quorum was present in both Houses, and the President's Message was delivered. (*See PUBLIC DOCUMENTS.*)

The seat of Roger A. Pryor, of Virginia, resigned, was taken by Mr. Collier. Mr. A. G. Jenkins, of Virginia, also resigned his seat in the House. As his district was mainly within the lines of the Federal army, there was no legal mode by which to fill the vacancy. In the House a number of bills were submitted, which indicate to some extent the nature of its business.

By Mr. Gartrell, of Georgia: A bill making Treasury notes a legal tender in payment of debts. This bill was made the special order for the 26th of August.

Also, a resolution instructing the Committee on Military Affairs to inquire into the expediency

of compelling the Commissary Department to furnish the soldiers with more and better food. Agreed to.

By Mr. Miles, of South Carolina: A bill to amend the conscription act. It extended the application of the law to all citizens under forty-five years of age. Referred.

Also, a bill to punish slaves taken in arms, and the white men assuming to be their officers. It provided that the slaves so taken should be delivered up to the authorities of the State in which captured, to be disposed of by its laws; and the white officers either to be hung or also delivered up to the State authorities. Referred.

By Mr. Foote, of Tennessee, a bill for retaliatory purposes. It recited that the enemy refused to treat the partisan soldiers as prisoners, and had also punished innocent private citizens for their acts. It provided that an officer who may have ordered such atrocities be put to death if captured. An equal number of prisoners (officers to be preferred) taken from the enemy to suffer the fate inflicted on the captured soldiers or citizens. Referred.

Also, a bill for the treatment of captives. It provided that any officer or private captured by the army, who should have committed any offence pronounced felonious by the laws of the Confederacy or any State, should be delivered up for trial. Referred.

Also, a bill to punish negroes in arms. It provided that Federal armies incongruously composed of white and black should not be held entitled to the privileges of war, or to be taken prisoners. Of such as may be captured, the negroes shall be returned to their masters or publicly sold, and their commanders to be hung or shot, as may be most convenient. Referred.

Also, a bill to retaliate for the seizure of citizens by the enemy. It provided that of the prisoners held by us a number equal to that of the citizens should be retained as hostages for their safety, and subjected to like treatment; any officers, civil or military, concerned in their seizure should be imprisoned during the war. Referred.

Also, a bill to provide for raising an additional force of 250,000 men. Laid on the table.

Also, a bill providing an export duty of twenty per cent. on cotton and tobacco, to aid in indemnifying the losses of citizens by the enemy.

A vote of thanks was tendered to Col. Forrest, the partisan leader, "for his recent victories in Tennessee."

That portion of the President's Message relating to the increase of the army was taken up. Mr. Foote of Tennessee referred to the manner in which the conscription act had been passed. Its constitutionality at the time of passage was doubted, and if the plan prescribed in it should be allowed to grow into a system, it would be subversive of State sovereignty and popular freedom. The necessity which

was alleged to exist formerly, for the present law no longer existed, and even that necessity was artificial, having grown out of the failure of the Provisional Government to provide for expected deficiencies in the army in season. He insisted that two hundred and fifty thousand men could be raised by requisition upon the States sooner than in any other way, and would not awaken distrust or alarm, nor occasion any collision with State authorities. If the new law recommended by the Secretary of War should be adopted, collision with Virginia, Tennessee, and all the other States would be inevitable, as it would sweep into its vortex all the militia now or to be organized. Nothing but a military despotism could be the result.

Mr. Dargan, of Alabama, contrasted the present condition of the army with the past. He thought every man should be subject to the call of the President.

Mr. Bonham, of South Carolina, was in favor of raising troops as was done when we resisted Great Britain, and as we did in 1812.

In the Senate, on the same day, the Committee on Military Affairs reported a bill prohibiting the employment of substitutes, except for persons skilled and actually employed in some mechanical pursuit important to the public interest, or where the person is the only white male adult on the farm or plantation having thereon not less than fifty slaves. If the substitute deserts, however, the person who employed him was to serve. The second section provides that the commanders of brigades and divisions, under certain restrictions, may detail to any farms or plantation worked by slaves, when the owner is a *femme sole*, a minor, or a person in the public service, one enrolled private for duty.

The bill was ordered to be printed.

A long discussion ensued upon a resolution, offered by Mr. Yancey, to transact business with open doors, instead of in secret session, against which there were loud complaints by the press and the people. The resolution was rejected.

On the 21st a bill was introduced declaring Kansas to be within the limits of the Southern Confederacy.

Mr. Clay introduced a bill providing that any "Federal officer, soldier, or adherent who may fall into our hands with counterfeit Confederate notes in his possession, or who may be proved to have passed off any such, shall be courtmartialled and punished with death."

In the House of Representatives, Mr. Foote offered a series of resolutions favoring an aggressive war; also favoring a proclamation to the inhabitants of the Northwestern States, offering to guarantee the free navigation of the Mississippi and Ohio rivers to their mouths if they will desist from the further prosecution of the war.

In the Senate, on the 2d of September, Mr. Semmes, of Louisiana, from the Finance Committee, reported a bill providing for the coinage

of copper (alloy) tokens, of the value of five, ten and twenty cents, to the extent of \$5,000,000, and the appropriation of \$200,000 for the purpose.

Mr. Sparrow, from the Committee on Military Affairs, reported back the petitions from various religious organizations, asking exemptions in certain cases, from the further consideration of which the committee was discharged.

Mr. Sparrow also reported a bill providing for the extension of the conscript age to forty-five, which was ordered to be printed, and made the special order for another day.

Mr. Brown, of Mississippi, from the Committee on Naval Affairs, reported a joint resolution of thanks to Commander Eben Farrand, and the officers and men under his command, for gallant services in repulsing the enemy's gunboats at Drury's Bluff, on the 15th of May last. Adopted.

The following Message, with despatches, from President Davis, was received and read.

*To the Senate and House of Representatives of the Confederate States:*

I have the gratification of presenting to Congress two despatches from Gen. Robert E. Lee, commanding the army of Northern Virginia, communicating the result of the operations north of the Rappahannock. From these despatches it will be seen that God has again extended his shield over our patriotic army, and has blessed the cause of the Confederacy with a second signal victory on the field already memorable by the gallant achievement of our troops. Too much praise cannot be bestowed upon the skill and daring of the commanding general who conceived, or the valor and hardihood of the troops who executed, the brilliant movement whose result is now communicated. After having driven from their intrenchments an enemy superior in numbers, and relieved from siege the city of Richmond, as heretofore communicated, our toil-worn troops advanced to meet another invading army, reinforced not only by the defeated army of Gen. McClellan, but by the fresh corps of Gens. Burnside and Hunter. After forced marches, with inadequate transportation, and across streams swollen to unusual height, by repeated combats they turned the position of the enemy, and forming a junction of their columns in the face of greatly superior forces, they fought the decisive battle of the 30th, the crowning triumph of their toil and valor. JEFFERSON DAVIS.

The House resolution, voting thanks to Captain Raphael Semmes, of the Confederate States steamer Sumter, was referred to the Military Committee.

The bill amendatory of the act to organize bands of partisan rangers, restricting the privilege of raising such bands, as given by the original bill, and also authorizing the Secretary of War to brigade them as troops of the line, was taken up.

A lengthy debate succeeded, sundry amendments were adopted, and, finally, the bill was defeated by a vote of 12 to 7.

In the House, on the 12th of September, Mr. Hilton, of Florida, from the Committee on Military Affairs, to whom were referred the Message of the President communicating the despatches from General Lee relative to the late victories, and the resolutions of the Senate in relation to the movement of the armies

across the Potomac, reported the following substitute for said resolutions :

*Resolved*, That the thanks of Congress and of the country are eminently due, and are hereby tendered to Gen. Robert E. Lee and the officers and men of his command for their late brilliant victories, culminating in the signal defeat of the combined forces of the enemy in the second great battle of Manassas.

*Resolved*, That Congress has heard with profound satisfaction of the triumphant crossing of the Potomac by our victorious army, and assured of the wisdom of that masterly movement, reposes with entire confidence on the distinguished skill of our commanding general, and the valor of his troops, to achieve, under favor of the Great Ruler of nations, new triumphs, relieve oppressed Maryland, and advance our standards into the territory of the enemy.

*Resolved*, That the President be requested to communicate the foregoing resolutions to General Lee and the officers and men under his command.

Mr. Hilton advocated the immediate passage of the resolutions.

Mr. Lyons moved to amend the second resolution by striking out all after the words "distinguished skill of," and inserting in lieu thereof, "the commanding general and the valor of his troops to relieve oppressed Maryland, and, under favor of the Great Ruler of nations, achieve new triumphs over the enemy." He approved the movements of our armies thus far, and thought a resolution of thanks eminently proper; but if it were passed with the words proposed to be stricken out, it would be an invitation from Congress to advance into the enemy's country, and that was a responsibility which he, for one, was not prepared to assume.

Mr. Miles, of South Carolina, was somewhat surprised to hear a sentiment indicating hesitation from the gentleman who had just taken his seat. The press throughout the country had clamored for an onward movement, and wherever the people assembled we had always heard the same sentiment expressed—that we were pursuing a mistaken policy in waiting for the enemy to advance, and that our armies should advance and pluck victory upon the enemy's soil. After we had commenced this aggressive policy, and our armies were across the borders, we are told by the gentleman from Virginia that we ought to hesitate.

Mr. Lyons said that the gentleman had mistaken his position. He stated plainly that he approved of Gen. Lee's crossing the Potomac and threatening Maryland; but at that point, with his present information, he was constrained to stop—he could not take the responsibility of advising an advance into Pennsylvania.

Mr. Miles still differed with the gentleman from Virginia. What he meant by an aggressive war was to carry the war into the enemy's country, and this was what the resolutions said. They had been carefully and deliberately weighed in the committee, and they were expressive of the unanimous sentiment of the gentlemen who composed it. What the people wanted was an aggressive war. While the enemy had overrun our territory and reduced

our people to a condition of bondage without parallel in the history of warfare, were we to hesitate to retaliate upon them? He could not believe any such sentiment. The resolution, in his opinion, could not be construed as an instruction to our generals; but, when we have their assurance that they will bear our standards onward, and will relieve oppressed Maryland, shall we hesitate because, forsooth, they may not be able to carry out the plan? The resolutions were intended to encourage our President, our generals, and our armies. He wished every branch of government to understand that this Congress does not think the war has been hitherto waged upon a mode best calculated to bring it to a speedy close. He was opposed to Congress assuming the conduct of the war, but he hoped the people would understand that we do propose to wage an offensive warfare.

Mr. Lyons asked if the gentleman believed that our army, great and glorious as it is, could safely go into the heart of the North.

Mr. Miles replied that he did. He would endorse the language of a well known gentleman—give Jackson half of our present army, and he would drive the whole 600,000 of the North before him. Mr. M. closed by enforcing the opinion that the time to strike was while our armies were flushed with success, and while they were veteran troops, accustomed to the roar of battle.

Mr. Conrad, of Louisiana, was in favor of the amendment. He viewed the resolutions as an instruction to our armies, and thought our President and generals better qualified than Congress to conduct the war. It was not a war of conquest, but a war for independence; everybody agreed in that, and hence there was no difference in opinion as to the policy of the war. The mode of conducting it ought to be left alone to the Executive, without interference from Congress or elsewhere. He believed that the conduct of the war up to this moment had been just what it ought to have been.

Mr. Ayer, of South Carolina, was in favor of the aggressive policy. He would say to the Executive, we desire that the enemy's country shall be invaded, and leave it to him to judge of its expediency. He would have our armies.

Go with banner, brand and bow,  
As foeman meets his mortal foe.

He would not assume to speak for all; but so far as his constituents were concerned he knew this to be the prevailing sentiment.

Mr. Foote moved the previous question, which was sustained.

Mr. Goode, of Virginia, demanded the yeas and nays on the motion to strike out and insert.

The roll was then called, and Mr. Lyon's amendment was defeated by the following vote:

YEAS.—Messrs. Arrington, Ashe, Atkins, Barksdale, Boccock, Bridgers, Conrad, Conrow, Currin, Curry, Davidson, Dupre, Farrow, Garland, Gentry, Hanly, Johnson, Jones, Kenan, of Georgia, Lyons, Machen, McDowell, McLean, Read, Roston, Smith, of Alabama Smith, of North Carolina, Swan, Villere—29



**NAYS.**—Messrs. Ayer, Batson, Bell, Bonham, Boteler, Boyce, Breckinridge, H. W. Bruce, E. M. Bruce, Chambliss, Chrisman, Clapp, Clark, Clopton, Collier, Cook, Crockett, Dargan, Davis, Dawkins, De Jarnette, Elliott, Ewing, Foote, Foster, Freeman, Gardenheir, Gartrell, Goode, Graham, Gray, Harris, Hartridge, Heiskell, Herbert, Hilton, Hodge, Holcomb, Holt, Kenan, of North Carolina, Kennar, Lander, Lyon, Marshall, Menees, Miles, Moore, Munnerlynn, Perkins, Preston, Pugh, Russell, Sexton, Strickland, Tibbs, Trippe, Vest, Welch, Wilcox, Wright, of Georgia, Wright, of Texas—61.

The substitute of the committee was then agreed to, and the question recurring upon the passage of the resolutions,

Mr. Smith, of Alabama, addressed the House in opposition to the second of the series, being unwilling to commit himself to an aggressive policy. He did not believe in advancing into the enemy's country. We had not been invited into Maryland, and it was a question of time, and yet to be learned, what reception we would meet with upon the soil of Maryland. We had been driven from the soil of Kentucky after having been invited thither. We had to fight Kentuckians, steel to steel, and knee to knee, and this had promoted our disasters. The gentleman from South Carolina had indicated that the people had forced an unwilling Administration to depart from its policy, and that the Government of the Confederate States may be opposed to an aggressive policy. Could it be possible that the President of the Confederate States, who was known to be so wise in military affairs, as well as a wise civilian, should be driven into undue haste, and made to change his whole policy, and to yield to popular clamor?

Mr. Hodge, of Kentucky, replied to the remarks of the last speaker in relation to that State, showing that the enemies of the South there were not natives. The true sons of Kentucky had shed their blood freely on many well fought fields in behalf of the Confederacy. When the time comes that arms can be placed in the hands of her people, Kentucky will do her duty, or her sons will be found lying dead upon the field with their feet to the foe.

Mr. Foote, of Tennessee, answered the positions assumed by the gentleman from Alabama (Mr. Smith), and favored the passage of the resolutions. Toward the conclusion of his remarks, he said it was known officially that our army had crossed into Maryland, and were on their way to Harrisburg. He hoped not two days would elapse before the plan would be consummated. He would not say it was for the purpose of conquest—it might be for the purpose of destroying railroad communications, or for some other object not proper to mention. The God of battles he believed was with us, and he had perfect confidence that the acting out of the present aggressive policy would give us the most complete success that could be desired.

Mr. Barksdale, of Mississippi, took the ground that Congress had no right to pronounce upon the policy of the war, in the manner that had been asserted in the debate to-day. If a plan

had been agreed upon by the leaders of our army in secret council, it was criminal in this Congress thus to make itself a council of war, and proclaim that plan to the world.

Mr. Machen, of Kentucky, combated the idea of running over the enemy's country roughshod, though he was not entirely opposed to the policy of invasion. He thought, if we could capture and hold Cincinnati, the Northern people could be brought to terms, and made to give up their accursed cause. He would vote for the resolutions, but wanted the generals to be left free to decide for themselves.

Mr. Heiskell, of Tennessee, moved the previous question, which was ordered, and the vote being taken, the first resolution passed unanimously, the second by 63 yeas to 15 nays, and the third unanimously.

Mr. Kenan, of Georgia, moved a reconsideration of the vote by which the second resolution was adopted.

On motion of Mr. Davis, of Mississippi, the motion to reconsider was laid upon the table—ayes 45, noes 26.

Mr. Kenan desired to offer an additional resolution, declaring that Congress does not intend to indicate in these resolutions a policy different from the policy of President Davis, nor to indicate a plan for the conduct of the war.

Mr. Foote said that he had intended to offer a resolution to show that by the action just taken it is not intended to pass upon the military policy of the Administration, but to harmonize with and sustain the same.

The Speaker decided that neither of the resolutions could be entertained.

Mr. Jones, of Tennessee, moved that the title of the resolutions be amended so as to read: "Joint resolutions in relation to the movements of Gen. Lee's army and General Congressional Order No. 1."

Mr. Gentry, of Tennessee, availed himself of the opportunity to address the House upon this motion. He held that the resolutions undertook, in effect, to indicate the policy which Congress desired the Executive to pursue. He thought the war had been well and gloriously conducted, and that it was unwise in Congress to interfere. With regard to the policy of invading the enemy's country he was not prepared to commit himself.

Mr. Miles offered a substitute for the title proposed by Mr. Jones, as follows: "Joint resolutions in relation to the late victories and the crossing of the Potomac by the Army of Northern Virginia."

The amendment offered by Mr. Jones was rejected—yeas 13, nays 56—and the substitute of Mr. Miles adopted.

In the House, on the 26th of September, the Committee on Foreign Affairs, to whom had been referred several resolutions relative to the true policy of the war, and recommending to the President to issue a proclamation touching the free navigation of the Mississippi and its

tributaries, and the opening of the market of the South to the inhabitants of the Northwestern States upon certain terms and conditions—reported :

A majority were in favor of the resolutions, and a minority opposed. The majority recommended a vigorous prosecution of the war with invasion of the enemy's territory. Relative to a proclamation of the freedom of the Mississippi and the opening of the Southern markets to the inhabitants of the Northwestern States, they said :

Such a proclamation as that recommended in the resolution referred to the committee, it is confidently believed, would have a tendency greatly to strengthen the efforts of the advocates of peace in the Northwestern States, be calculated to bring those States quickly into amicable relations with the States of the South, withdraw them ultimately altogether from their present injurious political connection with the States of the North and East, with which they have really so little in common, and thus enable us to dictate the terms of a just and honorable peace from the great commercial emporium of that region through whose influence mainly has this wicked and unnatural war been thus far kept in progress.

The minority of the committee reported, that in their opinion it was a work of supererogation for the House to decide on the policy on which the war should be conducted. As to opening the Southern markets to the inhabitants of the Northwestern States they say :

The undersigned dissent from the recommendation that this Government should tender to a portion of the citizens of the Government with whom we are at war exclusive commercial privileges. It is not the part of wisdom to commit our Government to any fixed policy in advance. Legislation should not be anticipated, but should be shaped by existing events. If a deviation from this plain suggestion of wisdom be advised in the present instance upon the idea of the influence of an appeal to the self-interest of the inhabitants of the Northwestern States, it should not be forgotten that the same argument might, with equal propriety, be addressed to the inhabitants of the New England States. The manufacturers of that section would be conciliated by pledges that a discriminating tariff would at the close of hostilities, be put into speedy operation for building up their interests, and ship-owners would be propitiated by pledges that they would be permitted to perform the carrying trade of the South as under the old Union. And the city of New York would be induced to pause in her course of folly and wickedness toward the Confederate States if assured that they would confer upon her the privilege of conducting their commercial affairs, and enriching herself upon the proceeds of her labor.

The Northern people derived, under the former Government, an annual profit of not less than \$100,000,000 upon Southern trade. Their implements of war will be laid aside when assured that their coffers shall be filled with the proceeds of Southern labor. But the undersigned do not hesitate to repel the suggestion that the people of the South are willing to purchase peace by such a sacrifice of their rights, and by so degrading a concession to Northern cupidity. To be respected, our course must be firm and our legislation rational and just.

At an early period after the organization of the Government of the Confederate States a law was passed declaring the free navigation of the Mississippi river, with certain salutary restrictions. The policy of the Government has not been changed on this subject. It is presumed to have been known to the inhabitants of the Northwestern States before they embarked in a wicked and unjustifiable war against the people of the

Confederate States. To proclaim this policy at the present time, coupled with offers of their lucrative trade, in the manner suggested by the majority, would be, in the highest degree, derogatory to the dignity of the Government. It would bring upon it the imputation of pusillanimity. It would be accepted by the enemy as a confession of conscious weakness, and its inevitable tendency would be to prolong the war.

The undersigned are firm in the opinion that the most effective mode of conquering a peace is not to be found in extending to the enemy propositions of reconciliation, but in the vigorous prosecution of the war.

The signs of returning reason, indicating a desire for peace among the inhabitants of the Northwestern States, upon the discovery of which the majority have congratulated the House, are believed to be delusive. The undersigned regret to say that they have not been able to discern them. But, in the event of the actual existence of these alleged pacific indications, it is clear that they are the result, not of temporizing expedients on the part of the Government of the Confederate States, but of its manifestation of purpose to prosecute the war with vigor and effect.

For these reasons the undersigned dissent from the views of the majority, and ask the concurrence of the House in the opinion that they should be rejected.

E. BARKSDALE,  
J. R. McLEAN,  
W. R. SMITH.

The second conscription bill to call into service all persons above thirty-five years of age, led to a disagreement of the two Houses, when a committee of conference was appointed by each. In the House the following debate took place on the report of the committee.

A message was received from the Senate stating that they had agreed to the report of the committee of conference in relation to the bill "further to provide for the public defence."

Mr. Miles, of South Carolina, from the committee of conference, reported that the committee recommended that the House concur in the report of the committee of conference.

Mr. Boteler, of Virginia, obtained the floor.

Mr. Foote hoped the gentleman did not rise to call the question. If he did, he appealed to him by every consideration of courtesy and patriotism not to do it.

Mr. Boteler replied that he was blind to any appeal to courtesy, and to everything but the welfare of his country, at the present moment. Whatever his will might have been, his patience was exhausted, and many an hour had been lost already in discussion. He had recently returned from the army of the Potomac, and he had heard the appeals of soldiers made again and again, asking when reinforcements were coming. It is now time that the eternal talk on this bill should cease. It was an easy matter to vote down the question if gentlemen did not desire to sustain it; but he was impelled by a sense of duty. He did call the question upon the bill, and he should adhere to it.

The call of the question having been sustained, the bill was passed, 59 to 24.

Mr. Kenan, of Georgia, moved to reconsider the vote by which the bill had been passed. The measure just passed struck out the only adjustment looking to peace between the State and Confederate Governments—that by which

the House bill had authorized the President to make a requisition upon the Governors of the States for the troops needed. Is it proper, at a time like this, to create dissension and collision in any State of this Confederacy? Where could be the objections to this feature of the bill? He would always sustain the Government, but there had always been dissension upon the conscript law. In the State of Georgia it had been declared null and void because it was unconstitutional. He had no doubt but if the President were to make requisitions upon the Governors they would be complied with. He could tell gentlemen now there was danger of dissension between the Government and States in this Confederacy. He hoped it could be avoided, but he greatly feared it would come. Therefore he appealed to the House to reconsider the vote by which they passed the Senate bill.

Mr. Foote said that he was very happy that the gentleman from Georgia had found that opportunity to address the House, which the gentleman from Virginia (Mr. Boteler) had so ungraciously refused him. The House had been informed by a member of the state of things in the State of Georgia. That member had said that there was danger of a collision between the States and the Confederate Government. He would tell the House that a similar state of things existed elsewhere. There have been facts reported which showed it. Why should the House be restricted to the edict, and be dictated to as to what course it should pursue by a party of consolidationists in the other legislative branch of the Government? Mr. Foote said that he spoke of some who were then outside of the hall, and not in the other branch of the Government. It was well known that some time since he had emphatically declared, in unequivocal language, that there was danger existing, and now they had it from the lips of a high-toned gentleman from Georgia, making magnanimous disclosures in relation to the condition of the country, and appealing to them not to involve this country in civil war. By the bill of the House the country would have been quieted, and an abundance of soldiers procured for the war. Let all the consolidation men of this day, and all the federalists of the old Government cry out; let all those who have been enemies of State rights, and those who voted against paying back the fine of Gen. Jackson, all consolidationists and federalists, utter their sentiments in a voice of thunder; let them come on, he was done, he had had his say; he had expressed his opinion, and called the question.

The House refused to reconsider—yeas 24, nays 53.

Subsequently an exemption act was passed. It exempted the police for sections of country which have dense negro populations; also, editors and such helps as they require in their business; also, the employes of transportation and telegraph companies, ministers of the gospel, physicians, shoemakers, tanners, blacksmiths,

wagon makers and millers; also, superintendents and employes in hospitals, wool, cotton, and paper mills, employes of the government works, overseers of plantations, and one man to every five hundred head of cattle. The exemption act, passed April 21st, was repealed.

Several propositions under the form of bills, were introduced into the Senate respecting retaliatory measures. These propositions were brought forward in consequence of the proclamation of President Lincoln, issued on the 22d of September, declaring that on the 1st of January ensuing an emancipation proclamation would be issued. The subject came up for the first time on the 29th of Sept., when Mr. Semmes, of Louisiana, offered the following resolution:

*Resolved by the Congress of the Confederate States,* That the proclamation of Abraham Lincoln, President of the United States of America, issued in the city of Washington, in the year 1862, wherein he declares "that on the first day of January, in the year of our Lord 1863, all persons held as slaves within any State, or designated parts of a State, whereof the people shall be in rebellion against the United States shall be henceforth and forever free," is levelled against the citizens of the Confederate States, and as such is a gross violation of the usages of civilized warfare, an outrage on the rights of private property, and an invitation to an atrocious servile war, and therefore should be held up to the execration of mankind, and counteracted by such retaliatory measures as in the judgment of the President may be best calculated to secure its withdrawal or arrest its execution.

Mr. Clark, of Missouri, moved that the resolution be referred to the Committee on Foreign Affairs. He was in favor of declaring every citizen of the Southern Confederacy a soldier, authorized to put to death every man caught on our soil in arms against the Government.

Mr. Semmes, of Louisiana, said that the resolution had not been drawn without reflection. The question of retaliation was exclusively an Executive one, to be regulated by circumstances. But it was proper that the legislative department of the Government should express its approval of the retaliation contemplated by the resolution.

Mr. Henry, of Tennessee, said that the resolution did not go far enough. He favored the passage of a law providing that, upon any attempt being made to execute the proclamation of Abraham Lincoln, we immediately hoist the "black flag," and proclaim a war of extermination against all invaders of our soil.

Mr. Phelan, of Mississippi, said that he had always been in favor of conducting the war under the "black flag." If that flag had been raised a year ago the war would be ended now.

Mr. Burnett, of Kentucky, moved that all of said resolutions be referred to the Committee on the Judiciary. This was agreed to.

Subsequently, on the 1st of October, a majority of the Judiciary Committee made a report recommending the passage of the following bill:

Whereas, these States, exercising a right consecrated by the blood of our Revolutionary forefathers, and recognized as fundamental in the American system of government, which is based on the consent of the

governed, dissolved the compact which united them to the Northern States, and withdrew from the Union created by the Federal Constitution; and whereas, the Government of the United States, repudiating the principles on which its founders, in their solemn appeal to the civilized world, justified the American Revolution, commenced the present war to subjugate and enslave these States under the pretext of repressing rebellion and restoring the Union; and whereas, in the prosecution of the war for the past seventeen months, the rights accorded to belligerents by the usages of civilized nations have been studiously denied to the citizens of these States, except in cases where the same have been extorted by the apprehension of retaliation, or by the adverse fortune of the war; and whereas, from the commencement of this unholy invasion to the present moment, the invaders have inflicted inhuman miseries on the people of these States, exacting of them treasonable oaths, subjecting unarmed citizens, women, and children to confiscation, banishment and imprisonment; burning their dwelling houses, ravaging the land, plundering private property; murdering men for pretended offences; organizing the abduction of slaves by government officials and at government expense; promoting servile insurrection, by tampering with slaves, and protecting them in resisting their masters; stealing works of art and destroying public libraries; encouraging and inviting a brutal soldiery to commit outrages on women by the unrebuked orders of military commanders, and attempting to ruin cities by filling up the entrances to their harbors with stone: And, whereas, in the same spirit of barbarous ferocity the Government of the United States enacted a law, entitled "An act to suppress insurrection, to prevent treason and rebellion, to seize and confiscate the property of rebels, and for other purposes," and has announced by a proclamation, issued by Abraham Lincoln, the President thereof, that in pursuance of said law, "on the 1st of January, 1863, all persons held as slaves within any State, or designated part of a State, the people whereof shall be in rebellion against the United States, shall be thenceforward and forever free," and has, thereby, made manifest that this conflict has ceased to be a war as recognized among civilized nations, but on the part of the enemy has become an invasion of an organized horde of murderers and plunderers, breathing hatred and revenge for the numerous defeats sustained on legitimate battle fields, and determined, if possible, to exterminate the loyal population of these States, to transfer their property to their enemies, and to emancipate their slaves, with the atrocious design of adding servile insurrection and the massacre of families to the calamities of war; and, whereas, justice and humanity require this Government to endeavor to repress the lawless practices and designs of the enemy by inflicting severe retribution: Therefore, the Confederate States of America do enact,

1. That on and after the 1st of January, 1863, all commissioned and non-commissioned officers of the enemy, except as hereinafter mentioned, when captured, shall be imprisoned at hard labor, or otherwise put at hard labor, until the termination of the war, or until the repeal of the act of the Congress of the United States, herein before recited, or until otherwise determined by the President.

2. Every white person who shall act as a commissioned or non-commissioned officer, commanding negroes or mulattoes against the Confederate States, or who shall arm, organize, train, or prepare negroes or mulattoes for military service, or aid them in any military enterprise against the Confederate States, shall, if captured, suffer death.

3. Every commissioned or non-commissioned officer of the enemy who shall incite slaves to rebellion, or pretend to give them freedom, under the aforementioned act of Congress and proclamation, by abducting, or causing them to be abducted, or inducing them to abscond, shall, if captured, suffer death.

4. That every person charged with an offence under this act shall be tried by such military courts as the

President shall direct; and after conviction, the President may commute the punishment, or pardon unconditionally, or on such terms as he may see fit.

5. That the President is hereby authorized to resort to such other retaliatory measures as in his judgment may be best calculated to repress the atrocities of the enemy.

Mr. Phelan, of Mississippi, submitted a minority report from the same committee, in the form of a lengthy preamble, and the following resolution:

*Be it resolved, &c.*, That from this day forth all rules of civilized warfare should be discarded in the future defence of our country, our liberties and our lives, against the fell design now openly avowed by the Government of the United States to annihilate or enslave us: and that a war of extermination should henceforth be waged against every invader whose hostile foot shall cross the boundaries of these Confederate States.

Mr. Hill, of Georgia: I must be allowed to say for myself that I regard the proclamation of Mr. Lincoln as a mere *brutum fulmen*, and so intended by its author. It is to serve a temporary purpose at the North. I fear we are dignifying it beyond its importance. As the Senate has concluded to notice it, I am in favor of the simplest and most legal action. We must confine our action within the line of right, under the laws of nations. In my opinion we have the right to declare certain acts as crimes, being in conflict with civilized war, and the actors as criminals; and a criminal, though a soldier, is not entitled to be considered a prisoner of war. While, therefore, I approve the general idea to treat persons guilty of certain acts as criminals, contained in the bill reported by the Senator from Louisiana (Mr. Semmes), and agreed to that report as being the one most favored by the majority of the committee, I also, in accordance with the understanding of the committee, propose the following bill, and ask that it be printed for the consideration of the Senate:

1. That if any person singly, or in organized bodies, shall, under pretence of waging war, kill or maim, or in any wise injure the person of any unarmed citizen of the Confederate States, or shall destroy, or seize, or damage the property, or invade the house or domicile, or insult the family of such unarmed citizen; or shall persuade or force any slave to abandon his owner, or shall, by word or act, counsel or incite to servile insurrection within the limits of the Confederate States, all such persons, if captured by the forces of the Confederate States, shall be treated as criminals and not as prisoners of war, and shall be tried by a military court, and, on conviction, suffer death.

2. That every person pretending to be a soldier or officer of the United States, who shall be captured on the soil of the Confederate States, after the 1st day of January, 1863, shall be presumed to have entered the territory of the Confederate States with intent to incite insurrection and abet murder, and unless satisfactory proof be adduced to the contrary, before the military court before which the trial shall be had, shall suffer death. This section shall continue in force until the proclamation issued by Abraham Lincoln, dated at Washington, on the 22d day of September, 1862, shall be rescinded, and the policy therein announced shall be abandoned, and no longer.

Mr. Clark, of Missouri, read a preamble and resolution embracing his views on the subject under consideration. The resolution proposed

to recognize the enemy as "savage, relentless, and barbarous," and declares that it "is the duty of the Government of the Confederate States neither to ask quarter for its soldiers nor extend it to the enemy until an awakened or created sense of decency and humanity, or the sting of retaliation, shall have impelled our enemy to adopt or practise the usages of war which prevail among Christian and civilized nations."

On the motion of Mr. Semmes, of Louisiana, the several bills and resolutions were ordered to be printed.

The whole matter was finally disposed of on the last day of the session by the passage of a resolution, declaring that Congress would sustain the President in such retaliatory measures as he might adopt. (*See PRISONERS, and PUBLIC DOCUMENTS.*)

In the Senate, on the 7th of October, the bill to extend the operation of the sequestration act to all persons, natives of or residents within any State of the Confederate States, who have refused to submit themselves to the constitution and laws of the Confederate States, &c., was considered.

A substitute proposed by the Committee on the Judiciary was adopted. This substitute provides that the President of the Seceded States shall issue his proclamation ordering all persons within the limits of those States who adhere to the United States Government to leave the Southern Confederacy within forty days on pain of forfeiture of property. Another of its provisions is the granting of immunity to all persons adhering to the United States Government who, within forty days, should take the oath of allegiance to the Southern Confederacy.

The following is a sketch of the debate on this bill, which, however, failed to become a law at this session:

Mr. Clark, of Missouri, opposed the bill, because it would work a hardship upon good citizens of the South, who had acquiesced in the Yankee rule under duress, and were still within the Yankee lines. If citizens of the South could be given a fair chance to join our cause and still adhere to the enemy, he would be in favor of nailing them to the cross.

Mr. Haynes, of Tenn., took the same views.

Mr. Wigfall, of Texas, thought the bill entitled to serious consideration. It was not clear to him that it was entirely constitutional. Citizens and residents of the States of the Confederacy who had afforded aid and comfort to the enemy had been guilty of treason—a crime defined by the Constitution, and for which said citizens were responsible to their States and to the Confederate States.

Mr. Hill, of Georgia, held that every citizen had the right to elect with which Government, that of the North or the South, he would side. The Southern Government had the right to say whether residents or citizens who did not take sides with us but with the enemy, should leave

its limits and go over to the territory of the enemy. If a citizen has once elected to be a citizen of one of the Confederate States, that act makes him a citizen of the Confederacy, and he cannot throw off his allegiance. It belongs to the Confederate Government to define who are alien enemies. These rules had prevailed in all revolutions—in England and in the Netherlands.

Mr. Wigfall said the gentleman was as much mistaken as Abraham Lincoln or William H. Seward if he thought this was a revolution—that we were subjects fighting against an established Government. If we were we would be entitled to the term "rebels." This is no civil war. It is a war of some sovereign States against other States. There was civil war in Kentucky, where citizens of the same State were at war against one another. There was no such thing as a citizen of the Confederate States. No citizen owed allegiance to the Confederate States.

Mr. Hill held that the citizen did owe allegiance to the Confederate States. Gentlemen might call it "obedience," but this was a sublimated theory. The States have formed a Confederate Government, to which is delegated the sovereign power to declare war, &c. The citizen's first allegiance is due to his State, but through the State he owes allegiance to the Confederate Government.

He held, however, that the people had a right to choose their own Government. If this were not so, then the United States had the right to hang Gen. Buckner for proving false to the allegiance he once owed to them. This conclusion was inevitable. And the Confederate States would have a right to hang Andrew Johnson for violating an allegiance to the Government to which he never admitted he owed allegiance.

Gentlemen, he said, may shake their heads at the proposition as much as they please, but when they deny it, they deny a fundamental principle of the Government, and the people who accept the contrary rule of action are drifting on a rapid current into monarchy. You come to the old exploded doctrine that a man who once owes allegiance always owes allegiance; you deny the principle of expatriation in toto; you say a man shall render allegiance to a Government even before he has promised it; that no man has a right to choose his Government; and, finally, that Government does not rest upon the consent of the governed. This is monarchy. I deny that you can take a man by the nape of the neck and force citizenship down his throat. Citizenship is made up as well of the consent of the individual as of the Government. Neither party has a right to violate it against the consent of the other, and by that violation bind the other, unless it be upon terms before agreed upon. You cannot, therefore, hang a man as a traitor to a Government that has been made without his consent.

I do not know what particular acts Andrew Johnson may have done which would imply he intended to become a citizen of this Government. I say that when his State seceded he had a right to abandon his State; and if he did, in good faith, abandon that State, he is an alien enemy, and not a traitor. How far his specific act goes, of attempting to represent Tennessee in the United States Senate, is another question. I am not putting it upon that ground. I ask this: Do you hold Andrew Johnson, who abandoned the State of Tennessee and never came under obligation to the Confederate Government, to be a traitor? Can he be a traitor? I am discussing the general proposition. I say that, as regards every man who held allegiance to the United States originally, while he had a right to adhere to that allegiance, there was no power on earth could break his allegiance against his consent. This proposition I assert, and when a gentleman denies it he need not talk about State rights and individual rights. He erects the Government into a despotism, whether it goes by the name of monarchy, aristocracy, or democracy. If you can lay hold of a citizen and tear him loose against his will from his acknowledged allegiance, you exercise the greatest power a tyrant is capable of exercising. I say again that no power can rightly force a man to break his allegiance. The very violation of allegiance implies a consent of the will.

The senator says that there are no citizens of the Confederate States. But the Constitution says there are. "The electors in each State shall be citizens of the Confederate States." The gentleman says it does not mean that. I should suspect any theory that drove me to destroy or change the language of the Constitution itself. Here it is plainly written; and because I abide by it the gentleman calls me a "nationalist." God save the mark!

Mr. Wigfall: I hope he will.

Mr. Hill: I have always understood that the fundamental principle of State rights is, that the power shall be found in the grant, and that it is to be defined by the words used, and that "construction" was the old theory of the nationalists. We will take the doctrine of State rights, if we go by the letter. The words are, "citizen of the Confederate States." The gentleman, to save State rights, steps in and begins to construe. "It did not mean that; I grant that it says so, but it does not mean it." Who construes? He not only applies words not used, but changes words used, puts in words, reads new meanings, and talks to me about construction and "nationalism." It is not a question; it is not used in that one single sense, but here it is again: "No person shall be a representative who has not attained the age of twenty-five years, and been a citizen of the Confederate States." It did not mean it, of course. But it says, furthermore, "No person shall be a Senator who shall not have attained the age of thirty years, and been a

citizen of the Confederate States." Now, unless my friend will admit he is a citizen of the Confederate States, he ought to be ousted from his seat in this body; he is incompetent to hold it by the Constitution—that is, by the Constitution as it reads. Of course, if my friend is allowed to decide by "national" and "federal" rules, to construe the Constitution, to pay no attention to what it says, but only to what he thinks or desires it to mean, he will be entitled to his seat.

Mr. Semmes: I would like to ask the senator one question. This Constitution says "the people of the Confederate States." Do you suppose it means other than the citizens of the States?

Mr. Hill: I certainly do not. They become citizens of the Confederate States through the States, except they be aliens. I grant that no person can be a citizen of the Confederate States who is not a citizen of some one of the States, but it does not follow that a citizen of a State is necessarily a citizen of the Confederate States. Gentlemen may indorse sublimated theories that define our Constitution after the manner of the interpreters of the will in Dean Swift's "Tale of a Tub." They wanted to construe it, not according to what it said, but according to the measure of their own wishes. The text did not suit them, so they took sentences; but sentences would not give the meaning, so they took words; they could not find the right consecutive words, so they took syllables, and, finding they would not do, they selected letters, and putting them together they made a will to suit their taste. Gentlemen upon the same principle may destroy the Constitution, and make it mean what they please, in order to accomplish their purposes. But I am thus much of a State rights man: I deny the Confederate Government has any power not granted; and I say you must look to the language of the grant to find the extent of the power, and that which necessarily results from the grant—the power to carry out the grant must be in the grant. The language "citizens of the Confederate States" is used in the Constitution no less than three times. It is true, they are first citizens of the respective States, but they become citizens of the Confederate States through the States compacting together—confederating together.

The Constitution also declares what shall be treason against the Confederate States. What is treason? A violation of one's allegiance. A gentleman gets up to argue or to intimate that a man cannot owe allegiance to the Confederate States on account of some legislation in North Carolina—

Mr. Oldham: Do you argue he can?

Mr. Hill: I say he can owe allegiance to the Confederate States as far as the Constitution binds him. He did not owe original allegiance, I grant.

Mr. Oldham: Obedience.

Mr. Hill: Treason is defined by jurists and

by dictionaries as the violation of one's "allegiance"—that is the word.

Mr. Oldham: I will explain the purport of my question. I hold that every citizen of a political community owes allegiance to the sovereign power. In this country the people are the sovereign power, and every citizen owes allegiance to the political community that constitutes his State. He owes obedience to the State Government which that community may establish as the agency; and, whenever this sovereign directs him to change that obedience to any other source, he is bound to obey in consequence of his allegiance to his sovereign. He owes precisely the same allegiance to this sovereign as the people of Great Britain owes to the English Crown.

Mr. Hill: I do not quibble about words. I do not care by what circumlocution you arrive at the origin of allegiance. I do not care how a citizen owes allegiance, or by whose allegiance, or by whose agency he gets to owe allegiance. All I say is that under the Constitution every citizen of the Confederate States owes allegiance to the Confederate States. You may call it obedience.

Mr. Oldham: I only desire the gentleman not to confound terms.

Mr. Hill: He confounds terms himself. He gets up a word to define authority, and employs the same to overturn authority.

Mr. Oldham: Our Government overturned authority.

Mr. Hill: It did not say the treason we define is different from the treason that has been settled for all time. One of the definitions is, that treason shall consist in levying war against the Government. It adjudicates upon cases coming within the meaning of the word. What is meant by the word? A breach of one's allegiance. The gentleman says it is a breach of one's obedience. Then, I suppose a violation of the law may be made treason—for that is disobedience. Desertion or any other violation of a penal statute may be made treason. You may call it allegiance or obedience. I say citizens of this Government owe that which only citizens can owe—they owe allegiance; and if they violated that allegiance they can be hung. You need not go and read your sublimated theories to the man upon the gallows; you need not try to comfort him by saying it is all wrong to hang a man for violation of his allegiance, but ought first to decide his obedience. I fear he would be hung before you conclude your rhapsodies.

There is no necessity for the introduction of these theories to bring about a conflict between the State Governments and the Confederate Government. My idea—I do not know whether it is a national one or not; certainly it does not depend upon a change of words in the Constitution, upon refined arguments and well spun theories for its justification—is this: the States were originally sovereign, independent States—they are original and sovereign yet—and as

such they had a right to exercise absolute and sovereign power. They have by their own free will and consent delegated these sovereign powers to a common Government. And they made it a Government, not simply an agency, for they call it a Government in the compact, and they have said all citizens of the respective States shall be citizens of the Confederate States. They have established laws requiring these citizens to obey that which the States have agreed they shall obey—the common compact.

To the extent of the powers delegated, the Confederate Government exercises the sovereign power. I grant that it did not have original, national sovereignty—nor do I care whether it has or not. It has the power to declare war, the power to make money, to collect duties, and these powers are sovereign powers; they are expressly delegated to the Confederate Government. Violence done to the Government, by a citizen, is treason, because it is a violation of the citizen's allegiance. I admit that the men who were originally citizens of the States, and who are yet citizens of the States, owe their first allegiance to the States, but through the States they owe allegiance to the Confederate Government. The State, of course, under certain circumstances, has a right to qualify that allegiance; and I say when you dissolve the compact the citizen has a right to elect. If we, upon the part of the Government, will exercise powers plainly delegated to us, and exercise none that are not delegated, there will never be any conflict between the States and the Confederate Government. If the States will exercise their reserved powers properly, and the Confederate Government exercises its delegated powers properly, there will never be any difficulty.

I say to gentlemen here who make such a clamor in defence of State sovereignty, for which they say this war has been waged, that if they will recur to history they will find that the great cause of the disruption was the interference, by States, with a compact into which they had solemnly entered. No man found cause for dissolution in anything the Federal Government did; for all declared they wanted to preserve the Union until Lincoln was elected. Not against the Supreme Court—that tribunal was faithful to the last. Not against the Federal Congress, for there you had a majority. Not against Mr. Buchanan—*par excellence* the man chosen by the South. What was the difficulty, Mr. President? The Northern States, sir, passed their personal liberty bills and nullified the acts of Congress. The State Governments would not render up fugitives, declaring they were not criminals because they stole negroes, which were not property; and the State judges took it upon themselves in their State courts, to set aside the acts of Congress for carrying out the fugitive slave law. These were the enormities that drove the South to her condition of determined secession. I know that, through my section of the country, these facts

had more influence upon the popular mind than any other; and when Mr. Lincoln was elected it was thought he was seeking not to continue the Federal Government, but pervert the Government, and to accomplish, through Federal agency, what the Northern States had already sought to do. That perfected the argument.

I am not national, in one sense; I am not Federal in another, I am sure. I regard the reserved rights of the States as much as any other man, and will never seek to intrench upon them. The powers I am sworn to exercise I will exercise with strict reverence for the purposes of the grant. I think if we would all go to work in the exercise of delegated powers, and act instead of theorizing, we would accomplish more satisfactory results for the people.

Mr. Wigfall: I propose to answer the gentleman, with the simple prefatory remarks, that I am as much astonished at his recollection of the facts as his avowal of principles. For a senator to rise in this Confederate Congress, within a few brief months after the nation has been dissolved, and declare the Federal Government of the United States never trespassed upon our rights—

Mr. Hill: I never said that.

Mr. Wigfall: If you did not, you said something bearing a wonderful resemblance to it.

Mr. Hill: I said the trespasses of the Federal Government were not the evils alleged by the people in seceding; it was not the trespasses of the Government that influenced the people to secede. I said it was the trespasses of the Northern States in their faithlessness to the common compact. I always held the Missouri compromise was unconstitutional, and things of that sort; but the Federal Government, as such, did not commit these trespasses which drove the people to secede.

Mr. Wigfall: Well, I ask, if they had any complaint against the judiciary?

Mr. Hill: None.

Mr. Wigfall: I need not ask him about the legislative branch, for he says we had no cause of complaint here. "Surely not," he says, "for you had a majority there." His language is plain and unmistakable. Why, sir, in that Congress the Black Republicans had an overwhelming majority in the House against us, and a tie vote in the Senate, with a Black Republican casting vote.

Mr. Hill: It was not from any act of the Supreme Court or of Congress, or of the Federal Executive, we seceded. I do not say they always did right. I was utterly opposed to the administration of Mr. Buchanan.

Mr. Wigfall: He forgets Congress passed a law abolishing slavery in the District of Columbia, declaring no slave should be sold there.

Mr. Hill: When did it pass?

Mr. Wigfall: In 1850.

Mr. Hill: And the people expressly said they would not secede on account of it.

Mr. Wigfall: I do not know what Georgia politicians said.

VOL. II.—18 A

Mr. Semmes: I call the gentleman to order.

The President: The gentleman will make no remarks not pertinent to the issue.

Mr. Wigfall: The senator asks if Andrew Johnson is a traitor. He gets up and makes a terrible do about my denying the right of taking up arms to resist tyranny, and trying to hold men to their allegiance. I never denied any such right. A man may change his allegiance, provided he does it in good time and good faith. No man has ever asserted the contrary—and if it were not for the lax notions of the senator about the organization of the Government, and the patent, palpable errors he has fallen into heretofore on this question, I should be surprised at the attitude he assumes. He asks when did Andrew Johnson become a citizen of the Confederate States? (I use that term—we are obliged always to use it—the meaning is, a citizen of Tennessee when it entered the Confederate States.) He was a citizen of Tennessee originally. When Tennessee became one of the Confederate States he was in the position of every other citizen of Tennessee. He never disavowed his allegiance to Tennessee; on the contrary, he pretended to represent her in the Federal Senate, and he went back there, and pretended to be Governor. How was he released from his allegiance? Tennessee becoming one of the Confederate States, he was obliged to give obedience to her laws, or become amenable to indictment and conviction for treason if he gave aid and comfort to the enemy, or levied war against her. The Constitution the senator has relied upon so confidently in support of his position has also the clause, "We the People," equivalent to saying we do not mean the people of one single consolidated nationality, but the people of the several States.

Mr. Hill: I have never contended it was consolidated.

Mr. Wigfall: The other sentence I allude to is in the second clause of the fourth article, in which it says, "citizens of each State shall be entitled to all the privileges and immunities of citizens in the several States," &c. I don't conceive any additional argument necessary to combat the gentleman's most untenable position.

This debate was terminated by laying the bill on the table.

Subsequently Mr. Foote reported resolutions, which were referred to Committee on Foreign Affairs, to appoint a Joint Committee to address the people of California, Oregon, and the various Territories beyond the Rocky Mountains, on the expediency of hereafter establishing a league, offensive and defensive, between such States and Territories and the Confederate States.

An act was passed to encourage the manufacture of shoes and clothing for the army of the Confederacy. It provides for bringing into the country, duty free, of cards, card cloth, machinery, and other articles necessary for the purpose.

A bill was also introduced against foreign



counterfeiters of treasury notes. It provides that if such notes are introduced by officers, soldiers, and others of the United States, the offender shall be deemed guilty of felony, and suffer death on conviction in any military court.

Mr. Clay said he hoped senators would give this bill the attention it deserved. The enemy, by counterfeiting our currency, had aimed one of their deadliest blows at our cause. They had boldly advertised these counterfeits for sale, and among their dead, who fell in battle, it was rare to find one who had not upon his person more or less of spurious Confederate treasury notes. The faith in our currency of some of the loyal inhabitants of the Confederacy had already been impaired by the quantity of counterfeits which had found their way into circulation. Some law to repress this counterfeiting by the enemies of the Confederacy, by providing for their speedy punishment, should be passed. Mr. Clay moved to amend the bill by providing that persons charged with passing counterfeit notes, shall be tried by any military court or military commission, as provided by a law of Congress, instead of by the slower and more cumbersome mode of trial by court martial.

In the House of Representatives, Mr. Foote, of Tennessee, offered the following joint resolution proposing to send a commissioner to Washington empowered to propose terms of just and honorable peace :

*Be it enacted by the Congress of the Confederate States of America,* That the signal success with which Divine Providence has so continually blessed our arms for several months past would fully justify the Confederate Government in despatching a Commissioner or Commissioners to the Government at Washington City, empowered to propose the terms of a just and honorable peace.

Mr. Holt, of Georgia, asked the consent of the House to offer the following substitute for the resolution :

The people of the Confederate States are, and have been from the beginning, anxious that this war with the United States should be conducted with the sense established by the rules of civilized and Christian nations, and have, on their part, so conducted it, and the said people ardently desire that said war should cease and peace be restored, and have so announced from the beginning; therefore,

*Resolved,* That, whenever the United States Government shall manifest a like anxiety and a like desire, it shall be the duty of the President of the Confederate States to appoint — Commissioners to treat and negotiate with the said United States Government upon said subjects, or either of them.

On motion of Mr. Kenan, of Georgia, the resolution and substitute were laid upon the table — yeas 59, nays 26.

On the 8th of October, Elias C. Boudinot was admitted to a seat in the House as a delegate from the Cherokee Nation of Indians.

A bill was introduced into the House as a tax measure which proposed to collect for the support of the government and the defence of the country, one fifth the value of all the wheat, corn, rice, rye, oats, potatoes, hemp, flax, peas, beans, barley, hay, wool, rosin, tar, pitch, tur-

pentine, cotton, sugar, molasses, and tobacco produced in the Confederate States during the previous year; also one fifth the value of the increase of the horses, asses, cattle, sheep, swine, and also one fifth of the yearly incomes. Upon the collection of the tax a receipt was to be given, which should be exchangeable for income tax bonds bearing 6 per cent. interest. This bill was regarded as a forced loan, and failed to pass.

An act was passed making appropriations for the support of the government for the month of January, 1863, and for certain deficiencies and other purposes therein mentioned. Among the appropriations made by this act were the following: For the ordnance service, \$2,500,000; pay of the army, \$18,660,189; transportation of troops, &c., \$7,464,075; subsistence of prisoners of war, &c., \$200,000; bounty of fifty dollars to soldiers, \$3,000,000; medical and hospital supplies, \$400,000; to pay deficit in the post office department, \$800,000; for deficiencies in the quartermaster's department, \$39,000,000; interest on the public debt, for the month of January, 1863, \$2,500,000; subsisting the army for the month of January, 1863, \$6,571,672 91. The aggregate sum appropriated by it was nearly \$85,000,000.

A bill entitled "An act to provide for raising and organizing, in the States of Kentucky and Missouri, additional forces for the provisional army of the Confederate States," with a recommendation that the House concur in the amendments which authorize the President to appoint general and field officers for the organization of such troops, was also taken up in the House and passed.

In the Senate, on Oct. 11, the House bill to reduce the rate of interest on the funded debt of the Confederate States was passed, with an amendment fixing the rate of interest on the new issue of bonds at 7 per cent. instead of 6 per cent. A proviso was also added renewing the authority to issue 6 per cent. convertible bonds. A House bill to relieve the army of incompetent and disabled officers was also passed.

In the House, on Oct. 11, the Senate bill to punish and repress the importation of counterfeit treasury notes was passed, with an amendment. A substitute for the Senate bill fixing the seal of the Confederate States was adopted.

An act was also passed authorizing the Secretary of the Treasury to issue copper coins of the denomination of five, ten, and twenty-five cents to the amount of five millions of dollars, and appropriating \$200,000 to carry the act into effect.

Some change in the members of Congress took place near the close of this session. Chas. J. Jenkins was elected from Georgia to fill the vacancy occasioned by the resignation of Gen. Toombs. Samuel A. Miller was elected to fill the vacancy occasioned by the resignation of A. G. Jenkins, of Virginia.

CONGRESS, U. S. The second session of the thirty-seventh Congress\* convened at Washington on the 2d of December, 1861. At this session the legislation of Congress assumed a new aspect. Two positions were taken, which became the basis of the action of the controlling majority in that body on all subjects relating to the troubles of the country. The first one was that slavery was the cause of those troubles. Of course, all the power of the Government must be directed against this cause. This power was to be wielded in two ways, viz., by negative measures and by positive. The negative measures consisted in withholding all restraints upon the slave. Practical emancipation followed the progress of the armies. The slave could go wherever he pleased, and be fed and clothed when destitute at the public expense, and be protected from the apprehension of his master, unless the latter could prove his loyalty, although residing in a country where the Government of the United States was utterly unable to afford to him any protection. The positive measures consisted in emancipation in all places under

the exclusive control of the Government, in prohibiting the extension of slavery to territories, and in a universal emancipation in the disloyal States through confiscation. The second position taken was that, the Government was engaged in a struggle for its existence, and could, therefore, resort to any measure which a case of self-defence would justify. This was said to be one of the hitherto undeveloped powers of the Constitution, and was called the "war power." The limitations which are prescribed in the Constitution to the powers of the Government, were supposed not to apply under the existing circumstances of the country, but Congress could pass all measures which it considered necessary to sustain the Government in the exercise of its authority. Practically the Constitution is of no force under this view, so far as it relates to the measures deemed necessary; or it is regarded as silent on the subjects in question. If the Government is considered to be one simply of delegated powers, the question may naturally be asked, how Congress can legislate upon measures relative to which it has no power? If the Constitution

\* The following is a list of the members of both Houses:

## SENATE.

*Maine*—Lot M. Morrill, William P. Fessenden.  
*New Hampshire*—Daniel Clark, John F. Hale.  
*Vermont*—Solomon Foot, Jacob Collamer.  
*Massachusetts*—Henry Wilson, Charles Sumner.  
*Rhode Island*—James F. Simmons, Henry B. Anthony.  
*Connecticut*—James Dixon, Lafayette S. Foster.  
*New York*—Preston King, Ira Harris.  
*New Jersey*—John B. Thompson, John C. Ten Eyck.  
*Pennsylvania*—Edgar Cowan, David Willist.  
*Maryland*—Anthony Kennedy, James A. Pearce.  
*Delaware*—James A. Bayard, Willard Sanbury.  
*Virginia*—John S. Carlile, Waitman T. Willey.  
*Kentucky*—Lazarus W. Powell, Garrett Davis.  
*Ohio*—Benjamin F. Wade, John Sherman.  
*Michigan*—Zachariah Chandler, Jacob M. Howard.  
*Indiana*—Jesse D. Bright,\* Henry S. Lane.  
*Illinois*—Lyman Trumbull, O. H. Browning.  
*Wisconsin*—James E. Doolittle, Timothy O. Howe.  
*Iowa*—James W. Grimes, James Harlan.  
*Minnesota*—Henry M. Rice, Morton S. Wilkinson.  
*Missouri*—John B. Henderson, Robert Wilson.  
*Tennessee*—Andrew Johnson.  
*California*—Milton S. Latham, James A. McDougall.  
*Kansas*—Samuel C. Pomeroy, James H. Lane.  
*Oregon*—James W. Nesmith, Benjamin F. Stark.

## HOUSE.

*Maine*—John N. Goodwin, Charles W. Walton, Samuel C. Fessenden, Anson P. Morrill, John H. Rice, Frederick A. Pike.  
*New Hampshire*—Edward H. Rollins, Thomas M. Edwards, Gilman Marston.  
*Vermont*—E. P. Walton, Justin S. Morrill, Portus Baxter.  
*Massachusetts*—Thomas D. Elliot, James Buffinton, Benjamin F. Thomas, Alexander H. Rice, John B. Alley, Chas. E. Train, Goldsmith F. Bailey, Charles Delano, Henry L. Dawes, Samuel Hooper, Daniel W. Gooch.  
*Rhode Island*—William P. Sheffield, George H. Brown.  
*Connecticut*—Dwight Loomis, Alfred A. Burnham, Geo. C. Woodruff, James E. English.  
*California*—Aaron A. Sargeant, T. G. Phelps, F. F. Low.  
*New York*—Edward H. Smith, Moses F. Odell, William Wall, Frederick A. Conkling, Elijah Ward, Edward Haight, Charles H. Van Wyck, John B. Steele, Stephen Baker, Abraham B. Olin, Erastus Corning, William A. Wheeler, Socrates N. Sherman, Richard Franchot, Roscoe Conkling, E. Holland Duell, William E. Lansing, Ambrose W. Clark, Charles B. Sedgwick, Theodore M. Pomeroy, Robert B. Van Valkenburgh, Augustus Frank, Burt Van Horn, Elbridge G. Spaulding, Reuben E. Fenton, Benjamin Wood, James E. Kerrigan, Isaac C. Delaplaine, James B. McKean, Chaun-

\* Mr. Bright was expelled, and Joseph H. Wright appointed by the Governor.

cey Vibbard, Jacob P. Chamberlain, Alexander S. Dives, Alfred Ely.

*New Jersey*—William G. Steele, George T. Cobb, Nehemiah Perry, John T. Nixon, John L. N. Stratton.

*Pennsylvania*—William E. Lehman, John P. Verree, William D. Kelley, William Morris Davis, John Hickman, Sydenham E. Ancona, Thaddeus Stevens, James H. Campbell, Galusha A. Grow, Charles J. Biddle, Joseph Bailey, Edward McPherson, Samuel S. Blair, Jesse Lazear, James K. Moorhead, Robert McKnight, John W. Wallace, John Patton, Elijah Babbitt, Thomas B. Cooper, John W. Killinger, Hendrick B. Wright, Philip Johnson, James T. Hale, John Covode.

*Maryland*—Cornelius L. Leary, Henry May, Francis Thomas, Charles B. Calvert, John W. Crisfield, Edwin H. Webster.

*Virginia*—Charles H. Upton, Jacob B. Blair, Joseph Segur, William G. Brown, Kelliam V. Whaley.

*Ohio*—George H. Pendleton, John A. Gurley, Clement L. Vallandigham, William Allen, James M. Ashley, Chilton A. White, Richard A. Harrison, Samuel Shellabarger, Warren P. Noble, Carey A. Trimble, Valentine B. Horton, Samuel S. Cox, Samuel T. Worcester, Harrison G. Blake, James R. Morris, Sidney Edgerton, Albert G. Riddle, John Hutchins, John A. Bingham, Robert H. Nagen, William P. Outler.

*Kentucky*—Charles A. Wickliffe, George W. Dunlap, John W. Menzies, Aaron Harding, Samuel L. Casey, George H. Yeaman, Henry Grider, Robert Mallory, John J. Crittenden, William H. Wadsworth.

*Tennessee*—Horace Maynard, A. J. Clements.

*Indiana*—John Law, James A. Cravens, W. McKee Dunn, William S. Holman, George W. Julian, Albert G. Porter, Schuyler Colfax, William Mitchell, Daniel W. Voorhees, Albert S. White, John P. C. Shanks.

*Illinois*—Elihu B. Washburne, Isaac N. Arnold, Owen Lovejoy, Wm. Kellogg, Wm. A. Richardson, James C. Robinson, Phillip B. Fouke, John A. Logan, Anthony L. Knapp.

*Missouri*—Francis P. Blair, jr., Elijah H. Norton, John W. Noell, James S. Rollins, William A. Hall, Thomas L. Price, John S. Phelps.

*Michigan*—Bradley F. Granger, Fernando C. Beaman, Rowland E. Trowbridge, Francis W. Kellogg.

*Iowa*—William Vandever, James F. Wilson.

*Wisconsin*—John F. Potter, Luther Hanchett, A. Scott Sloan.

*Minnesota*—Cyrus Aldrich, William Windom.

*Delaware*—George P. Fisher.

*Oregon*—George K. Shiel.

*Kansas*—Martin F. Conway.

*Dakota*—John B. S. Todd.

*Nebraska*—Samuel G. Dally.

*Utah*—John M. Bernhisel.

*Nevada*—John Cradlebaugh.

*Colorado*—H. P. Bennet.

*New Mexico*—John S. Watts.

*Washington*—William H. Wallace.

was considered to be silent respecting the duties and powers of the Government amid such circumstances as existed, then it was asked if the law of nations was not a rule by which the Government should act in its treatment of the people of the seceded States. These questions were extensively discussed at this second session of the thirty-seventh Congress. To the American citizen, the history of his country presents no subjects of such serious importance.

In the Senate, immediately after the organization, Mr. Trumbull, of Illinois, gave notice "of his intention hereafter to ask leave to introduce a bill for the confiscation of the property of rebels, and giving freedom to the persons they hold in slavery."

The President's Message was sent to Congress on the next day. (*See ANNUAL CYCLOPEDIA, 1861, PUBLIC DOCUMENTS.*)

In the House, immediately upon its organization, Mr. Lovejoy, of Illinois, offered a joint resolution tendering the thanks of Congress to Capt. Wilkes. It declared that "the thanks of Congress are due and are hereby tendered to Capt. Wilkes, of the United States Navy, for his brave, adroit, and patriotic conduct in the arrest and detention of the traitors James M. Mason and John Slidell." It was immediately read three times and adopted. This resolution was referred to the Naval Committee in the Senate, and no further action taken upon it.

Mr. Colfax, of Indiana, offered the following resolution, which was adopted:

*Whereas*, Colonel Michael Corcoran, who was taken prisoner on the battle-field of Manassas, has, after suffering other indignities, been confined by the rebel authorities in the cell of a convicted felon: therefore,

*Resolved*, That the President of the United States be requested to similarly confine James M. Mason, late of Virginia, now in custody at Fort Warren, until Col. Corcoran shall be treated as all the prisoners of war, taken by the United States on the battle-field have been treated.

A similar resolution was offered by Mr. Odell, of New York, relative to John Slidell, in consequence of the imprisonment of Col. Alfred M. Wood. It was agreed to.

Mr. Eliot, of Massachusetts, then offered the following joint resolution on the conduct of the war:

*Resolved*, by the Senate and House of Representatives of the United States of America in Congress assembled,

1. That, in behalf of the people of these States, we do again solemnly declare that the war in which we are engaged against the insurgent bodies now in arms against the Government has for its object the suppression of such rebellion, and the re-establishment of the rightful authority of the national Constitution and laws over the entire extent of our common country:
2. That, while we disclaim all power under the Constitution to interfere by ordinary legislation with the institutions of the several States, yet the war now existing must be conducted according to the ordinary usages and rights of military service, and that during its continuance the recognized authority of the maxim that the safety of the State is the highest law, subordinates rights of property, and dominates over civil relations:
3. That therefore we do hereby declare that, in our judgment, the President of the United States, as the Commander-in-chief of our Army, and the officers in command under him, have the right to emanci-

pate all persons held as slaves in any military district in a state of insurrection against the national Government, and that we respectfully advise that such order of emancipation be issued whenever the same will avail to weaken the power of the rebels in arms, or to strengthen the military power of the loyal forces.

Its consideration was postponed to Tuesday of the ensuing week, and again postponed to Dec. 12.

Mr. Campbell, of Pennsylvania, offered the following:

*Resolved*, That, in legislating to meet the exigencies of the present rebellion, Congress should confiscate the property, slaves included, of all rebels, and protect the property and rights, under the Constitution and laws, of all loyal citizens.

Mr. Stevens, of Pennsylvania, also offered the following:

*Whereas*, slavery has caused the present rebellion in the United States; and *whereas* there can be no solid and permanent peace and union in this Republic so long as that institution exists within it; and *whereas* slaves are now used by the rebels as an essential means of supporting and protracting the war; and *whereas* by the law of nations it is right to liberate the slaves of an enemy to weaken his power: therefore,

*Be it resolved by the Senate and House of Representatives of the United States of America in Congress assembled*, That the President be requested to declare free, and to direct all of our generals and officers in command to offer freedom to all slaves who shall leave their masters, or who shall aid in quelling this rebellion.

Sec. 2. *And be it further resolved*, That the United States pledge the faith of the Union to make full and fair compensation to all loyal citizens who are and shall remain active in supporting the Union for all the loss they may sustain by virtue of this act.

The consideration of these resolutions was postponed. In the Senate, on the 4th of December, Mr. Saulsbury, of Maryland, offered the following joint resolution proposing a conference for the settlement of the existing national difficulties. This was the only proposition made at this session, which contemplated a peaceful adjustment of the difficulties between the North and South. It was publicly declared in South Carolina that more was to be feared from this proposition than from all the armies of the North:

*Whereas*, the people of the States of Virginia, North Carolina, South Carolina, Georgia, Florida, Alabama, Mississippi, Louisiana, Texas, Arkansas, and Tennessee, are in revolt against the constitutional Government and authority of the United States, and have assumed to secede from the Federal Union, and to form an independent government under the name of the Confederate States of America; and *whereas* the Congress of the United States, approving the sentiment expressed by the President, in his annual message, "that the Union must be preserved, and hence all indispensable means must be employed," and believing that kind and fraternal feeling between the people of all the States is indispensable to the maintenance of a happy and prosperous Union, and being willing to manifest such feelings on their part, to the end that peace may be restored to a distracted country, and the Union and Constitution be preserved and maintained, and inviting the coöperation of the people of the aforesaid States in the accomplishment of objects so beneficial to each and all, do resolve as follows:

*Resolved*, by the Senate and House of Representatives of the United States of America in Congress assembled, That Millard Fillmore, Franklin Pierce, Roger B. Taney, Edward Everett, George M. Dallas, Thomas Ewing, Horace Binney, Reverdy Johnson, John J.

Crittenden, George E. Pugh, and Richard W. Thompson be, and they are hereby, appointed commissioners on the part of Congress, to confer with a like number of commissioners, to be appointed by the States aforesaid, for the preservation of the Union and the maintenance of the Constitution, and that they report the result of their said conference to Congress for approval or rejection.

*Resolved*, That upon the appointment of commissioners, as hereby invited, by said States, and upon the meeting of the joint commission for the purpose of conference as aforesaid, active hostilities shall cease, and be suspended, and shall not be renewed unless said commission shall be unable to agree, or in case of an agreement by them, said agreement shall be rejected either by Congress or by the aforesaid States.

Mr. Sumner, of Massachusetts, objected to its reception. It was, however, received, and laid on the table.

Mr. Wilson, of Massachusetts, gave notice of his intention to ask leave to introduce a bill "to punish officers and soldiers of the Army of the United States for arresting, detaining, or delivering persons claimed as fugitives to any person."

Mr. Sumner, of Massachusetts, offered the following resolution :

*Resolved*, That the Secretary of War be requested to furnish to the Senate copies of any general orders in the military department of Missouri relating to fugitive slaves.

He said : " Mr. President, my attention has been called, by letters from St. Louis, to certain general orders purporting to come from Maj.-Gen. Halleck, in command of the department of Missouri, relating to fugitive slaves, wherein it is directed that such persons shall not be received within his camps, or within the lines of his force when on march; and that any such persons now within such lines shall be thrust out; and the reason strangely assigned for this order is, that such fugitive slaves will carry information to the rebels.

" Now, it is difficult to speak of an order like that and to keep within bounds. Besides being irrational and inhuman on its face, it practically authorizes the surrender of fugitive slaves beyond any constitutional obligation. Such an order must naturally be disheartening to our soldiers, and it gives a bad name to our country, both at home and abroad.

" Gen. Halleck is reputed to be a good tactician; but an act like this, with which he chooses to inaugurate his command, does not give to us assurance of any great success hereafter. He may be expert in all the details of military science; but something more than that is now needed. Common sympathy, common humanity, and common sense are needed in the conduct of this war. I take the liberty here of saying—and I wish that my words may reach him—that every fugitive slave that he surrenders will rise in judgment against him hereafter with a shame which no victory that he can win can remove."

The consideration of the resolution was postponed until the next day, when it was agreed to.

On the same day, the following resolution was adopted unanimously in the Senate :

*Whereas*, John C. Breckinridge, a member of this body from the State of Kentucky, has joined the enemies of his country, and is now in arms against the Government he has sworn to support: therefore,

*Resolved*, That the said John C. Breckinridge, the traitor, be, and is hereby, expelled from the Senate.

Mr. Wilson, of Massachusetts, offered the following resolution, which was referred to the Committee on the District of Columbia :

*Resolved*, That all laws now in force within the District of Columbia relating to the arrest of persons as fugitives from service or labor, together with all other laws concerning persons of color within the District of Columbia, be referred to the Committee on the District of Columbia; and that the committee be further instructed to consider the expediency of abolishing slavery in the District, with compensation to the loyal holders of slaves.

In the House, on the same day, Mr. Holman, of Indiana, offered the following resolution :

*Whereas*, this House, on the 22d day of July last, by an almost unanimous vote, adopted the following resolution, submitted to the House by Hon. J. J. Crittenden, of Kentucky :

" *Resolved*, by the House of Representatives of the Congress of the United States, That the present deplorable civil war has been forced upon the country by the disunionists of the Southern States now in revolt against the constitutional Government, and in arms around the capital; that in this national emergency Congress, banishing all feelings of mere passion or resentment, will recollect only its duty to the whole country; that this war is not waged, upon our part, in any spirit of oppression, nor for any purpose of conquest or subjugation, nor for the purpose of overthrowing or interfering with the rights or established institutions of the States; but to defend and maintain the supremacy of the Constitution and to preserve the Union with its dignities, equality, and the rights of the several States unimpaired, and that, as soon as these objects are accomplished, the war ought to cease :

And *whereas*, since that time, no event has occurred to change the policy of the Government: therefore,

*Resolved*, That the principles above expressed are solemnly reaffirmed by this House.

This was laid on the table: ayes, 71; noes, 65.

Mr. Dunn, of Indiana, also offered the following resolution :

*Resolved*, That the Committee on Foreign Affairs be instructed to inquire into and report whether it is practicable and expedient to obtain the rights and privileges of settlement and of citizenship in any part of this continent, or in the adjacent islands south of the United States, for the benefit of such free persons of African descent as may choose to emigrate thereto from the United States, or where such emigrants may form themselves into independent colonies, under such protection as may secure them from foreign molestation.

On the 5th of December, in the Senate, Mr. Trumbull, of Illinois, introduced his bill, according to previous notice, "for the confiscation of the property of rebels, and giving freedom to the persons they held in slavery. It provided for the absolute and complete forfeiture forever to the United States of every species of property, real and personal, and wheresoever situated within the United States, belonging to persons beyond the jurisdiction of the United States, or beyond the reach of civil process in

the ordinary mode of judicial proceeding, in consequence of the rebellion, who, during its existence, should take up arms against the United States, or in anywise aid or abet the rebellion; this forfeiture to be enforced against property in the rebellious districts through the military power, and against property in the other portions of the United States in which the judicial power is not obstructed by the rebellion, through the courts; and the proceeds of the property of each individual seized and forfeited, subject to the just claims of his loyal creditors, to be held for the benefit of loyal citizens despoiled of their property by the rebellion, and to defray the expenses incurred in its suppression. The bill also forfeited the claims of all rebels, and those who gave them aid and comfort, to the persons they held in slavery, declared the slaves thus forfeited free, and made it the duty of the President to provide for the colonization of such of them as might be willing to go, in some tropical country, where they might have the protection of the Government, and be secured in all the rights and privileges of freemen. The property belonging to traitors, or those giving them comfort, who might be convicted by the judicial tribunals, was to be forfeited on their conviction; the realty for life, and the personal property for ever."

Mr. Trumbull thus stated the principles in accordance with which this bill had been framed:

"The Constitution declares that Congress shall have power 'to declare war,' and 'make rules concerning captures on land and water,' 'to raise and support armies;' 'to provide and maintain a navy; to make rules for the government and regulation of the land and naval forces; to provide for calling forth the militia, to execute the laws of the Union, suppress insurrections, and repel invasions,' and 'to make all laws which shall be necessary and proper for carrying into execution the foregoing powers.' Acting under these grants of power, Congress has provided for bringing into service more than half a million of men who are now engaged in suppressing the insurrection; and has, to some extent, made rules for the government of these forces, which, as far as they go, are obligatory on them; but in the absence of any regulation as to how the army is to be used in suppressing the insurrection, its commander would be at liberty to make such use of it, consistent with the rules of civilized warfare, as he believed most conducive to the service of the state, and best calculated to secure the end for which it was called into being; upon the principle that every man intrusted with an employment, or duty, is presumed to be invested with all the power necessary to enable him to perform the service. Hence the authority of the army in the suppression of an insurrection to seize, imprison, or shoot the insurgents, to desolate the country they occupy, to seize and appropriate for the time being their property, and free the persons they hold in bondage, is as

ample and complete under the Constitution as that of a court in peaceful times to arrest, imprison, try, and execute a murderer.

"That the judicial tribunals have no right or power to interfere with the army in the exercise of its powers in suppressing an insurrection, either by issuing writs of *habeas corpus* or otherwise, is apparent, from the fact that the only ground on which the military authority can be invoked at all, is, that the judicial tribunals, being overborne, are incompetent to the task. The judicial authority ceases at the very point where the military begins. It may be, and often is, a delicate question to determine this particular point, and decide in what localities the military, and in what judicial authority should have sway. This the Constitution has left to be provided for by Congress, by declaring that it shall have authority to call forth the militia to suppress insurrection; and Congress, soon after the adoption of the Constitution, passed an act authorizing the President to call forth the militia for that purpose, whenever the laws of the United States were obstructed by combinations too powerful to be suppressed by the ordinary course of judicial proceedings; and by an act passed at the first session of the present Congress, the President is authorized, in certain cases, to declare the inhabitants of a State, or part thereof, in a state of insurrection, and make use of the army to suppress it. The responsibility, therefore, of determining when and in what districts of the United States the military power may be used to suppress a rebellion, is devolved by Congress on the Executive, and when the military power is called into requisition, the judicial authority can no more interfere with its action, than can the military with the judicial tribunals in time of peace. Under certain circumstances either may be called to the aid of the other. The courts sometimes make use of the military in aid of the execution of their powers, and the military would doubtless have like authority to make use of the aid of the judicial tribunals in districts under insurrectionary control, should they be deemed a proper means by the military power to aid in suppressing the rebellion. In each case the power called to the aid of the other, whether it be the military in time of peace to the assistance of the judicial, or the judicial in time of rebellion to the assistance of the military, would be subordinate to the power making the call."

The Constitution defines the offence of which the Southern people have been guilty, and prescribes the extent of their punishment. This fact seems to be overlooked by Mr. Trumbull. The bill was referred to the Committee on the Judiciary. On the same day, in the House, Mr. Gurley, of Ohio, offered the following resolution, which was adopted:

*Resolved*, That the Judiciary Committee be requested to inquire if a telegraphic censorship of the press has been established in this city; if so, by whose authority and by whom it is now controlled: to re-

port if such censorship has not been used to restrain a wholesome political criticism and discussion, while its professed and laudable object has been to withhold from the enemy important information in reference to the movements of the army.

He also, on the same day, introduced a bill "to confiscate the property of rebels, to liberate their slaves and employ or colonize the same, and for other purposes," which was referred to the Committee on Military Affairs.

On the same day Mr. Lovejoy, of Illinois, offered the following resolution :

*Resolved by the Senate and House of Representatives, in Congress assembled,* That the Secretary of War be, and he is hereby, required to revoke the first section of General Order No. 3, bearing date of November 20, 1861, of Major-General Halleck, commanding the Western Department.

[The section of Gen. Halleck's order referred to in the resolution was as follows :

HEADQUARTERS, DEPARTMENT OF MISSOURI, }  
St. Louis, November 20, 1861. }  
GENERAL ORDERS, NO. 3.

I. It has been represented that important information, respecting the number and condition of our forces, is conveyed to the enemy by means of fugitive slaves, who are admitted within our lines. In order to remedy this evil, it is directed that no such persons be hereafter permitted to enter the lines of any camp, or of any forces on the march; and that any now within such lines be immediately excluded therefrom.]

Mr. Lansing, of New York, offered the following substitute, which was accepted, and its consideration postponed :

*Whereas*, Major-General Halleck, of the Western Department, has issued an order prohibiting negroes from coming within the lines of our army, and excluding those already under the protection of our troops; and *whereas* a different policy and practice prevails in other departments, by the direct sanction of the Administration; and *whereas* said order is cruel and inhuman, and, in the judgment of this House, based upon no military necessity; therefore,

*Resolved*, That the President be respectfully requested to direct General Halleck to recall said order, or cause it to conform with the practice of the other departments of the army.

On the same day Mr. Bingham, of Ohio, offered the following, which was referred to the Judiciary Committee :

*Be it enacted by the Senate and House of Representatives of the United States of America in Congress assembled,* That all acts and parts of acts in force in the District of Columbia, which authorize the commitment to the jails of said District, of persons as runaways, or suspected or charged with being runaways, and of free negroes, mulattoes, and other persons found living idle and without visible means of maintenance; and all acts and part of acts which authorize the sale of persons so committed, for charges of commitment or jail fees, be, and the same are hereby, repealed; and to so commit, or imprison, or sell any person for the causes aforesaid, within said District, is hereby declared a misdemeanor, and any person or persons so offending after the passage of this resolution shall, upon indictment and conviction, be subject to a fine not exceeding \$500, and imprisonment not exceeding one year, nor less than three months, at the discretion of the court.

Mr. Riddle, of Ohio, offered the following, which was agreed to :

*Resolved*, That the Secretary of the Interior be requested to furnish to this House information as to the number of slaves now holden, or resident within the

District of Columbia, and of their estimated value; and also such information as he may possess as to their intellectual and moral condition.

Mr. Fessenden, of Maine, offered the following, which was agreed to :

*Resolved*, That the Committee for the District of Columbia be requested to report the number of fugitive slaves that have been confined in the Government jail in Washington within the last year and a half; by whom claimed, whether any have been returned to the claimants; by what authority, and to whom, &c.

In the House, on the 11th, the resolution relative to the order of Gen. Halleck abovementioned was considered.

Mr. Stevens, of Pennsylvania, said : " We all know—for we have seen it in the orders—that the successor of Gen. Fremont, more, I believe, for the purpose of hunting down Gen. Fremont than from any general principle, has ordered that all slaves that have been received within our lines by order of Gen. Fremont should be excluded and returned to their masters, and that, in future, none others shall be permitted to come within those lines, upon a pretence, which any man who reads must know is a false pretence, that they are spies, and carry intelligence to the enemy. That is too bald a pretence to secure the belief of a child even. That slaves who have run away from their masters and sought protection from us, should have any desire to return as spies, and give information to the enemy, seems incredible. All our information from every source, so far as I have heard, is that these persons never desire to return, and that they are faithful to those who protect them. I hope the resolution will be passed, for the purpose of affecting our generals everywhere else.

" We know that this system of excluding fugitives from labor from our lines, and returning them to their masters, was inaugurated by Gen. McClellan in Western Virginia. Afterward came the magnificent proclamation of Gen. Dix, when he sent down an army into Eastern Virginia, amidst enemies and secessionists—for I venture to say that in those counties of Virginia, as well as in the adjoining counties of Maryland, there are not fifty loyal men—which ordered, in effect, the arrest of all fugitive slaves which came to them, and their delivery of them to their masters, and to exclude them entirely from their lines, because special care was to be taken that nobody's slaves should be liberated.

" In my judgment, all these cases which I have recited are a disgrace to the profession of arms; and if done on the mere motion of the commanding generals, they deserve to have the epaulets stripped from their shoulders. If done by the direction of higher authority, I have only to say, God forgive them, for they know not what they do."

Mr. Lovejoy, of Illinois, followed, and said : " But I desire to state, in reference to the last remark of the gentleman from Pennsylvania, that it is my honest conviction that these orders are given by the promptings of the gener-

als themselves, and that they have no authority to issue them from the President. I am satisfied that that is true. While the President does not remove and cashier them, as I would do, yet I do not believe he has given them any authority whatever, directly or indirectly, to proceed in this inhuman and shameful manner; for it is the concurrent testimony of every general in the field—and it is in accordance with my own observation while in the western department—that these slaves never play the game of spy; and that they are truly loyal and faithful. I remember very well that Gen. McDowell, before that fatal battle, was careful to inquire of every fugitive whom he met in relation to the position and movements of the enemy, and the topography of the country. I am satisfied that they are the most reliable scouts we have; that they give us the best information we have; and I do think it is most shameful, and mean, and contemptible for a major-general of the United States to slander a race already degraded, poor, and despised. It is an utter shame."

Mr. Blair, of Missouri, replied: "I desire to state to the House, in justification of Gen. Halleck, what occurred between us when I called on him the day after that order was issued. I know I may speak of it, because he does not care to conceal his sentiments. I told him I believed his order would be misunderstood and misconstrued, as it has been here to-day. He told me then that he had no idea of contravening the law of Congress, or the policy of the Administration on this subject; that his simple object was to exclude from his camp—not his lines—persons who could convey information to the enemy. As an instance of what he intended to guard against, I will say that at Cairo it was the habit of slaves to come into camp from Kentucky and southeastern Missouri for the purpose of selling provisions, and then going back into Missouri and Kentucky, where they fell into the hands of the enemy, who exacted information from them. He desired to put a stop to this thing, and that was the moving cause of his having published this order. I believe that what he stated in reference to this matter can be corroborated by gentlemen who were at Cairo at the time; and he said, moreover, that he not only intended to exclude from his camp these fugitive slaves who came there, and then went back to the enemy's camp, but that he meant to exclude everybody, white and black; that he meant to make no distinction in the matter, but that it was a mere military order, to preserve the discipline of his camp, and prevent the enemy from getting information."

Mr. Fouke, of Illinois, made the following statement: "Inasmuch as Cairo has been alluded to, I will state the fact that the officers and soldiers there regard this order of Gen. Halleck as a most wise and salutary one. I care not what motives prompted him to make it, it was one which was much needed. The statement of my colleague in regard to the fidelity

of these slaves is, in the main, untrue. We were misled on the 7th of November last by one of them, and my own regiment was led into ambush, and suffered the consequences. You cannot, therefore, rely upon the fidelity and loyalty of the slaves of Missouri, or any other State. I merely state facts which are known to our whole army there; and let my colleague's views prevail, and there is an end of recruiting for the volunteer service in my section of the State. These negroes come into our camps to sell their produce, and then communicate to the enemy information regarding the situation of our army. These are facts; and I know that every man bearing arms there will substantiate what I say."

Mr. Lovejoy, of Illinois, replied: "The concurrent testimony of all these generals with whom I conversed was in contravention of the statement of my colleague as to the general principle, not in reference to that particular case. I would ask my colleague what became of the negro who betrayed his regiment? Will my colleague be kind enough to answer?"

Mr. Fouke answered thus: "I do not happen to know what became of him afterward. We fell into the engagement at half past ten o'clock in the morning and remained under fire until five o'clock in the evening, and I had no time to look after the negro, about whom my colleague seems to be more concerned than the wounded and slain upon the battle-field; and I think if he would pay less attention to the negro and more to the interests of his country, we would get along much better with this war."

Mr. Blair, of Missouri, added: "Gen. Halleck stated, in addition to what I have already said, that he intended to use those slaves who ran away from their masters if he could use them with advantage to the Government; that he intended, if he found that it would weaken the enemy, to take their slaves from them wherever he found them; but he did not intend that that class of persons, or any other unauthorized persons, should come into his camp."

Mr. Julian, of Indiana, followed, saying: "This resolution relates to the policy adopted by Gen. Halleck in his division of the army. I think that the policy of the Administration itself is in favor of delivering up to their masters such slaves as come into the camps. I state this from the fact that within the past few days a slave girl, claimed by a Mr. Jessup, of Cockskeyville, Maryland, found her way into the camp of Col. Brown, of the Twentieth Indiana regiment, and accompanied the regiment to Fortress Monroe. The master, learning her whereabouts, demanded his slave. Col. Brown refused to deliver her up. Application was then made to Secretary Cameron, who ordered Gen. Wool to have her delivered up to her claimant, which I understand, in pursuance of the order, he did. I infer, therefore, that the general policy of the Administration sanctions the conduct of Gen. Halleck in reference to

this matter, and renders necessary some action on the part of Congress, looking to a change of that policy."

Mr. Blair, of Missouri, replied: "I infer quite the contrary from the sentiments expressed by the President in his annual message. Whatever Mr. Cameron, or any other officer, may have done, I take what the President says to be at least an indication of his policy—and he is at the head of the Administration."

Mr. Kellogg, of Illinois, said: "The gentleman from Indiana charges pretty clearly that the Administration favors the line of policy indicated by the order under consideration. If the gentleman knows that President Lincoln, by any act or word communicated to this House, or spoken out of it, is in favor of it, I would like him to point to it now. I assume to say, however, that the Administration has had no hand, directly or indirectly, in the order of Gen. Halleck, or in shaping the policy which is in the general line of that order, as construed by my colleague. I am inclined to say this from watching tolerably closely the acts of the Administration, and reading, tolerably carefully, all that the President has said on the subject. I do not hesitate to say that the Administration is in no way complicated with the policy indicated in this order. I do not assume to say that the President is opposed to or in favor of it; but I do say, that no action of this Administration has induced that order, and that, in my judgment, the Administration will not indicate such a general policy."

Mr. Blair, of Missouri, again said: "I think, Mr. Speaker, that when the Congress of the United States shall itself have indicated a policy on this subject, and shall have passed a law justifying the Administration in taking such and such grounds, it will be time enough for us to censure the Administration or to censure others for not following the policy laid down by us. Up to this time no such policy has been indicated by Congress."

The resolution was subsequently laid on the table: yeas, 76; nays, 64.

On the next day Mr. Blair, by permission, read the following from Gen. Halleck:

HEADQUARTERS, DEPARTMENT OF THE MISSOURI, }  
St. Louis, December 8, 1861. }

MY DEAR COLONEL: Yours of the 4th instant is just received. Order No. 3 was, in my mind, clearly a military necessity. Unauthorized persons, black or white, free or slaves, must be kept out of our camps, unless we are willing to publish to the enemy everything we do, or intend to do. It was a *military*, and not a *political* order.

I am ready to carry out any lawful instructions in regard to fugitive slaves, which my superiors may give me, and to enforce any law which Congress may pass. But I cannot make law, and will not violate it. You know my private opinion on the policy of confiscating the slave property of the rebels in arms. If Congress shall pass it, you may be certain that I shall enforce it. Perhaps my policy as to the treatment of rebels and their property is as well set out in Order No. 13, issued the day your letter was written, as I could now describe it.

Hon. F. F. BLAIR, *Washington.*

The resolutions offered by Mr. Eliot, of Massachusetts, and others, were then taken up. (*See* p. 276.) Mr. Eliot, after explaining the resolution, said: "Our President may act, our commander-in-chief, within his province, and the officers under him in command may act, and I believe are called upon to act, by every consideration of humanity and of patriotism. And, coming from the commonwealth I represent, in part—a State which has performed no small service in this war—I call upon you to aid me in giving such expression of the judgment of this House as shall command respect. I am not here to boast of the bravery or the patriotism of Massachusetts soldiers. In their name and in their behalf I pray you to call upon the military arm to strike that blow more effective for peace and for freedom than armies or victories can be, and convert the slave, which is the power of the enemy, into the free man who shall be their dread. So shall the sword intervene for freedom! If I have read the history of Massachusetts aright, that is the intervention her fathers contemplated!"

Mr. Steele, of New York, replied: "There is a consideration, in my judgment, in opposition to these resolutions which we must heed, and that is this: that, whether right or wrong, a very large majority of the soldiers of our army are opposed to this anti-slavery agitation. Is it possible that these extreme measures are to be forced through Congress simply for the purpose of showing the sense of Congress upon this question, when gentlemen opposite tell us there is no need of any such laws? And do you suppose it can be done without demoralizing our army? These men have been educated all their lives in the idea that this agitation of the slavery question was unprofitable, and that it was likely to produce the very state of things which now exists; and they believe—whether right or wrong, they religiously believe—that the unnecessary agitation of this slavery question is the sole and only cause of all our troubles. Now, sir, let it be understood, let it be read in our camps, that this war is prosecuted, as has been more than intimated by the gentleman from Massachusetts, for the extinction of slavery, and I tell you, gentlemen, whether you believe it or not, the power of our army is paralyzed."

Mr. Conway, of Kansas, said: "To retain slavery under existing circumstances, in our body politic, would, in my judgment, evince the very worst kind of folly or wickedness. To eliminate it forever should be the unwavering determination of the Government. Nevertheless, the Administration refuses to heed such counsel, and persists in regarding the institution as shielded by such constitutional sanction as it is not at liberty to infract. The President, in his recent message to Congress, refers only incidentally to the subject; and indicates no policy whatever for dealing with the momentous question."

On the results of the war he said: "The suc-



cess of the Government in subduing upon its present plan the rebellious States must inevitably result in restoring the domination of the slaveholding class by reinstating the institution, under the forms of our constitutional system, in the powers, privileges, and immunities which have always pertained to it. Hence, such a policy is calculated to bring no lasting peace to the country, and utterly fails to fulfil the object to which a wise statesmanship would strive to direct the present momentous occasion.

"It is no answer to me to say that it would elevate to power in the South men of more agreeable manners, or even more gentle pro-slavery views, than are now on the stage. In truth, the character of the agents whom the slaveholders select to represent them has no important relation to the question. Men are of but little consequence in this case. It is a contest of principles. The rehabilitation of slavery in the Union brings with it the whole train of evils under which the country has suffered from the origin of the Government.

"There are many persons, however, who believe that slavery may be placed where it will be in the course of ultimate extinction; that, indeed, the effect of this war, in any event, will be so to weaken it in all the States in which it exists that it will be unable to recover from the shock thereby inflicted, but will languish and ultimately die, without a disturbing struggle.

"This is, in my judgment, a mistake. The inexorable and eternal condition of the life of slavery is, that it must not only hold its own, but it must get more. Such is the unchangeable law, developed from the conflict of slavery with the order of justice; and no one is competent to render a judgment in the case who does not recognize it."

Mr. Harding, of Kentucky, said: "I ask, sir, whether the President does not stand pledged before the country and the world to this conservative policy? It is plain that Congress and that this Administration all stand pledged in the most solemn manner to the people of this country to follow this line of policy, and not depart from it.

"It follows, then, that Congress and the President being pledged to this conservative policy, he cannot now, nor can Congress, swerve from it without a palpable and plain violation of the plighted faith of both. To sanction the policy proposed by these resolutions would be to turn the war away from its legitimate purpose, and indeed to turn the bayonets of our soldiers against the institution of slavery. It would not only be a departure from the policy heretofore indicated, but would in fact be a betrayal of the loyal States who have been induced with such great unanimity to vote men and money to carry on this war for the defence of the Government. Why, sir, common honesty would demand, if I induce a man to engage in any enterprise on stipulated conditions, that I should stand by him and ad-

here to my agreement. Let me put the case to the gentleman from Massachusetts (Mr. Eliot), who introduced these resolutions. I take the ground that this war should have nothing to do with the institution of slavery, any more than with any other State institution. Let slavery alone, it will take care of itself. Let me argue with the gentleman from Massachusetts, who moved these resolutions. The President and the Secretaries and Congress, by their action, have induced us with great unanimity to raise a very large army. Some six hundred thousand men have been brought into the field. Large amounts of money have been voted and expended. Direct taxes have been imposed even upon the necessaries of life. All this has been done to sustain, defend, and preserve the Constitution and Government of our fathers.

"But after our troops are in the field, and have their armor on, suppose I come up from Kentucky and propose to divert the war from its legitimate objects by urging that the regiments from Massachusetts should be employed part of their time in capturing and returning runaway slaves? Would not the representatives from that State rise up and denounce such a proposition with the deepest indignation? What, then, is it you propose? If it would be bad faith and a fraud upon your troops to employ them in capturing and returning fugitive slaves, I ask whether it would not be far more fraudulent and in bad faith to the loyal men of Kentucky who have girded on their swords and gone out to fight for the Union, to tell them that from this time forth they shall be engaged in making war upon the institution of slavery—a war for the destruction of their own property, and leading on to all the bloody horrors of servile insurrection?

"Sir, let me illustrate a little further, to show how destructive this policy is, and how strange it is that a man should be so far misguided as to permit himself to be influenced by it. We all know that a man's honest conviction of right, the burning zeal which he feels within him when he is engaged in this abolition war, or war of emancipation, is no evidence whatever that he is right. I remember that Paul himself was never more zealous than when he was breathing out threatenings and death; when he was persecuting, wasting, and destroying the churches of God; and he was doing all that in the name of religion, and 'verily thought he was doing God's service.' But when the scales fell from his eyes he saw things in their true light, and he was a different man. I would that the scales might fall from the eyes of every one. What has this question of slavery to do with this war? We have no more right to interfere with slavery in a Southern State than with the common school system, or any other local institution of a Northern State. Suppose I should arise here and propose a bill to abolish or radically change the common school system of Massachusetts,

and should urge that dangerous political heresies were taught in those schools, such as the higher law doctrine and various other wild and extravagant notions, tending to disqualify men for self-government, and to array them against the Constitution of our country; and that therefore these schools are at war with the spirit of our free institutions, and must be put down. Might not the gentleman from Massachusetts with great propriety interrogate me thus: 'Sir, have you any property or interest in Massachusetts?' 'None whatever.' 'Were you ever there?' 'Never.' 'Do you desire to go there?' 'Not at all; I am satisfied to live in Kentucky.' 'Do you ever expect to be in Massachusetts?' 'No.' 'Why then concern yourself about our local institutions?' 'Ah, but you forget, I am engaged in a *philanthropic line of business*; that is all.' [Laughter.] 'Well, sir, perhaps you had better turn your attention to Kentucky. I have known men to show much good sense and acquire fine fortunes by simply attending to their own business; but no man ever manifested the one or secured the other by intermeddling with and giving his time to matters which no way concerned him. All that ever was accomplished in that way has been to annoy others and benefit nobody.' How would I respond to that argument of my friend? I think I should 'give it up,' and immediately move to lay the bill upon the table.

"Now, that is exactly a parallel case with this. It is manifest that the Constitution of the United States secures to each State the right to have or not to have the institution of slavery—just as essentially so as it does the right to regulate your own common school system. We have no more right to make war upon the institution of slavery than upon any other local institution. The Constitution secures to each State the right of regulating its own domestic institutions; and it must necessarily protect slavery, as certainly as it protects your own common school system. Our wisest men, the President of the United States, the heads of departments, and Congress, having with united voice declared that we have no constitutional power upon the subject, how are you to escape from the difficulty?

"Sir, the Union cause in the border States has already lost more strength by the agitation of this question in Congress, at this session, than was lost by the defeat of our arms at Bull Run. Gentlemen should take care, lest in their great zeal to strike off the bonds of the slave they should be preparing chains and slavery for themselves and posterity.

"Sir, the fearful responsibility, the deep guilt and crime, of plunging this great country into all the horrors of civil war and bloodshed, does not rest alone upon the leading secessionists of the South; a full share of that criminal guilt is justly chargeable to the leading disunion abolitionists of the North. If this Government shall outride the angry storms now threatening

its destruction, and the fearful day of just retribution shall come, may it not be justly said to these leading spirits from the North and the South: You have been co-workers in the attempt to destroy the Government of your country. You of the North sought to dissolve the Union of these States, *professedly* to destroy slavery. You of the South sought to dissolve it, *professedly* to protect slavery. You were both disunionists—all rebels against the Government. As State after State plunged into the gulf of disunion, your shouts of triumph from the North rose up and met the peals of joy from the South. You have smitten a great country with desolation and waste. You have crimsoned fields with kindred blood. You have filled the whole land with weeping widows and orphans. In guilt and crime you have been banded together, like Siamese twins, through life, and you ought not to be separated in death. It is but just that you should expiate your enormous crime together, on the same scaffold, and together be buried in the same traitors' grave."

The resolutions were then referred to the Committee on the Judiciary: ayes, 77; noes, 57.

In the Senate on the 16th, Mr. Ten Eyck, of New Jersey, offered the following resolution, which was laid on the table and ordered to be printed:

*Resolved*, That the present war is for the Union, according to the Constitution; that its object is to save the former and enforce the latter—was so in the beginning, is now as carried on, and should be, to the last; that measures, extreme and radical, disruptive in themselves, involving in a common fate as well the loyal as disloyal, should not be resorted to; and that in crushing treason—wide-spread and hateful as it is—the Government itself cannot prove traitor to organic law.

Mr. Hale, of New Hampshire, offered the following, which was agreed to:

*Resolved*, That the Committee on Military Affairs and the Militia be instructed to inquire into the expediency and propriety of establishing by law a uniform mode of dealing with the slave of rebels escaping from their masters, or taken as prisoners by our Army.

Mr. Sumner, of Massachusetts, offered the following resolution, which was agreed to:

*Resolved*, That the Committee on Patents and the Patent Office be directed to consider if any further legislation is necessary in order to secure to persons of African descent, in our own country, the right to take out patents for useful inventions, under the Constitution of the United States.

Mr. Trumbull, of Illinois, offered the following resolution:

*Resolved*, That the Secretary of State be directed to inform the Senate whether, in the loyal States of the Union, any person or persons have been arrested and imprisoned and are now held in confinement by orders from him or his Department; and, if so, under what law said arrests have been made, and said persons imprisoned.

Mr. Dixon, of Connecticut, expressing his regret that the resolution had been introduced, said: "What are the arrests which the resolution proposes to consider? They are well known

to the country, so far at least as relates to their object and character. It is well understood that during the last six months, while our existence as a nation seemed for a time to hang upon a thread—while large armies threatened the capital, and its safety was, at one period, in great doubt, there were, in many of the loyal States, men of dangerous character and designs allowed to go at large, although it was well understood they were giving aid and comfort to the enemy in every possible manner. Some of them infested my own State. I am glad to be able to say that they were, for the most part, emissaries from other States, and that the disgrace of giving them birth, or of affording them a home, did not belong to us. They first manifested their treasonable purposes by attempting to institute a series of peace meetings (see ANNUAL CYCLOPÆDIA, 1861—*Connecticut*), so called, by which they hoped to debauch the public mind and prepare it for degrading submission, under the false pretence of restoring peaceful relations between the North and the South. What effect these meetings might have had in deceiving the more unthinking, does not appear; but acting in accordance with the wishes of almost our entire people, the Secretary of State put a sudden stop to their treasonable designs by arresting and confining one or more of the most obnoxious. It was precisely the right thing, done at precisely the right time; and it nipped treason in Connecticut in the bud. It struck terror to the hearts of all who sympathized with secession, and it encouraged the hearts and strengthened the hands of every true-hearted and patriotic citizen. It was, certainly, the opinion of many that the summary process of arrest and confinement did not go far enough; that others, equally guilty, ought to have been placed under restraint; but the desired effect was produced, and an appeal to the fears of a certain class accomplished what nothing else could accomplish.

“Now, sir, I maintain that the action of the Government in making the arrests alluded to was not only justifiable, but that not to have pursued it would have been moral treason on the part of the President. Was he to see the Government paralyzed by the unprincipled men who, under the false pretence of peace, were seeking to ruin the country by distracting and dividing our people? Was he to allow information and materials of war to be furnished to the enemy by open, avowed secessionists? For one, sir, I thank him—I thank the Secretary of State, as does every loyal citizen of Connecticut, for any and every arrest made there; and I shall not vote an inquiry into the legality of these arrests. They find their justification in the dire necessity of the times.”

Mr. Trumbull, of Illinois, replied: “I have said upon this floor that I believe the Constitution of the United States confers all the power which is necessary to enable the Government to crush this gigantic rebellion. Why? Because the Constitution confers on Congress

the power to raise armies to put it down, and when the power is given to raise armies to put down insurrection, the power comes also to crush it in the way that armies are accustomed to act. It is with powder and ball that it is to be done; and neither your jury trials nor your *habeas corpus* acts can interfere with the Army which, clothed with constitutional power to crush a rebellion, goes forth armed for the purpose of putting it down in the very way that armies subdue their enemies. But, sir, this is a resolution of inquiry, simply as to the arrest of persons in the loyal States. That is all it is. The Senator from Connecticut tells us there were persons in his State who were allowed to go at large when they were giving aid and comfort to the enemy. I am astonished at that. I should have supposed that in the goodly State of Connecticut men giving aid and comfort to the enemy would have been arrested and tried, and if convicted by a jury, would have been hung.”

Mr. Dixon, interrupting for explanation, said: “If the Senator will allow me, I will repeat to him what kind of aid and comfort those men gave to the enemy. I stated that they gave aid and comfort to the enemy by instituting a series of meetings, falsely called ‘peace meetings,’ in which they addressed large assemblages of the people, and attempted to debauch the public mind on the question of this war, claiming that we were the aggressors; that the South were acting in self-defence; that the Administration was making war upon the South. Now, sir, if the Senator can inform me how such men can be attacked by arms, by powder and ball, I shall thank him for the information. I do not know how they could be arrested for treason. I do not say they were guilty of open treason. They were guilty of moral treason; and the Secretary of State, to the great joy of every loyal citizen of Connecticut, imprisoned one or more of those men and put a stop to the whole proceeding. I thank him for doing it. I will not ask him a single question as to the provisions of the law or the Constitution upon which he acted.”

Mr. Trumbull responded: “The Senator assumes that these persons were traitors. Who is to decide that? He says he will ask no questions. Why, sir, how does he know that, in portions of this country where there is no disturbance and no insurrection, the right persons will be arrested? The unconstitutionality of such action as this seems to be admitted by the Senator who comes to the defence of this despotic power. Why, sir, the power—without charge, without examination, without opportunity to reply, at the click of the telegraph—to arrest a man in a peaceable portion of the country and imprison him indefinitely, is the very essence of despotism. I thought the Senator from Connecticut was engaged in a war to defend and uphold the Constitution. What, sir, becomes of constitutional liberty, what are we fighting for, if this broad ground is to be assumed and

to be justified in this body, and any man is to be thanked for assuming an unconstitutional and unwarranted authority? What are we coming to, if arrests may be made at the whim or the caprice of a cabinet minister? Do you suppose he is invested with infallibility, so as always to decide aright? Are you willing to trust the liberties of the citizens of this country in the hands of any man, to be exercised in that way? May not his order send the Senator from Connecticut or myself to prison? Why not?

"Now, sir, I am for regulating this thing by law. That is the object of my inquiry. If additional legislation is necessary for the purpose of punishing persons who sympathize with treason in Connecticut, or in any other loyal State of this Union, where the laws can be enforced through the judicial tribunals, I say let us give that additional legislation, and let us not sanction the exercise of such high powers as these outside of the law, and as the Senator says, 'on the plea of necessity.' Why, sir, I deny the necessity. The principle contended for would justify riots and mobs in punishing criminals wherever found. Suppose a man has committed an offence apparent to the whole country, shall the citizens of the country get together and execute the man without trial; or imprison him and hold him in prison without trial? Is that the way the laws of the country are to be administered? Has the Constitution no meaning, and are laws to have no efficacy? We shall have anarchy at once if such doctrine is to prevail."

Mr. Dixon, of Connecticut, again replied: "I confess I never have heard anything in the Senate, which filled me with more astonishment than the remarks which have fallen from the Senator from Illinois; and they have strengthened me in the opinion that this resolution ought not to pass. He talks about the whim and caprice of the Secretary of State. Sir, I deny here, on behalf of that officer of the Government, that he has been actuated by whim or caprice. I say he was compelled to take the course he did; and, if he had not, he himself would have been a moral traitor. Now, if we are told that we ought to pass laws providing for such cases in the future, I have not the least objection. If the Senator refers to the future, very well. Let him make a law, if he can, which shall define the powers of the President in such a case. Let it be a precedent for the future; let it be a guide for the future, if we should ever be placed hereafter in similar circumstances. But when the Senator proposes to go back six months, and inquire of the Secretary whom he has arrested, why he has arrested him, and for what reason; and when he talks about innocent persons being arrested, and then discharged, I cannot comment upon it. I can only express my surprise that language like that should fall from a Senator known to be so devoted as he is to the cause of the country and the Constitution."

Mr. Wilson, of Massachusetts, followed. He said: "I regret, Mr. President, that the Senator from Illinois has introduced this resolution, and I deplore the speech he has made in its support. That Senator knows, as we all know, that the Secretary of State, in obedience to the order of the President of the United States, has made arrests in the loyal States. Why then ask the Secretary if such arrests have been made, and the law upon which they were made? If the Senator does not approve of the action of the Secretary of State in making those arrests, or rather the action of the President of the United States in ordering those arrests, instead of reflecting on the Secretary of State or the President, why does not that Senator come into the Senate with a bill proposing to enact a law that shall clothe the Government of this country with ample powers to arrest and imprison men who are in complicity with traitors? Why is it necessary at this time, in this crisis of our country's history, threatened by domestic traitors and by foreign Powers, to come into the Senate of the United States with a resolution that carries an implied censure with it upon the executive Government of the country?"

Mr. Hale, of New Hampshire, immediately rose and said: "Mr. President, instead of feeling grief and mortification and regret at the introduction of this resolution, I thank my friend from Illinois for introducing it. I think it eminently proper, eminently appropriate; and I shall feel mortified if the day has come when any act of your Executive may not be inquired into by his sworn constitutional advisers, the Senate of the United States. If, in answering that resolution, if it passes, the Secretary of State or the President shall deem it proper to send it to us under the seal of executive secrecy, I shall find no fault with that; but the right, the power, the propriety, and the necessity of making this inquiry, to my mind, eminently exists. What is the purpose of this inquiry? Have not arrests been made in violation of the great principles of our Constitution? If they have, let us know it, and let us know the necessity which impelled them. If the fact be that such arrests have been made, and if the necessity exists upon which they were made, then I trust there is magnanimity, there is justice, there is patriotism, there is forbearance enough in this Senate and in this Congress to throw the mantle over every act that has been prompted by a patriotic impulse to serve the nation and preserve its liberties. You may gain your victories on the sea, you may sweep the enemy from the broad ocean and from all its arms and from all its rivers, until you may hoist, as the Dutch admiral once hoisted at the head of his flag-staff, a broom, indicative that you have swept the ocean of your foes, and you may crush every rebel that is arrayed against you and utterly break their power; and when you have done all that, when you have established a military Power such as

the earth never saw, and a naval power such as England never aspired to be, and constitutional liberty shall be buried amid the ashes of that conflagration in which you have overcome and destroyed your foes; then, sir, you will have got a barren victory, and with all your glory you will have but achieved your everlasting shame."

Mr. Kennedy, of Maryland, followed. He said: "Mr. President, I do not know that I could add one word to the remarks that have been made by the Senator from New Hampshire, if I felt so disposed. I do not rise now for the purpose of entering into any debate upon the propriety of this resolution, but simply to express to the Senator from Illinois my hearty thanks for its introduction at this time. I believe it to be eminently proper and just. I think that the condition of the country, and especially of the loyal States, now demands some investigation of this sort. Arrests were made in the loyal States months ago that were charged to have been made without the authority of law. They were vindicated upon the ground of public necessity. It was said that we were then in the beginning of a great rebellion; that the whole country was in a state of alarm and terror, and that it was considered expedient and proper for the Government to use all the means it could command to suppress the insurrection, without reference to the existing laws at the time."

Mr. Doolittle, of Wisconsin, moved to refer the resolution to the Committee on the Judiciary.

Mr. Trumbull, of Illinois, objected, saying: "If there is a disposition in the Senate to make any inquiry into these matters, let us know it; and let us know it by a direct vote upon the resolution. I want to know whether or not we are fighting for the Constitution, and for constitutional liberty regulated by law. I hope the resolution will not be referred."

Mr. Pearce, of Maryland, opposed the reference, saying: "I want to know what is the ground upon which the Secretary rests this power. I want to know whether it is anything which we can find in the Constitution, directly or by implication, or whether it is a fancy of his, that in these troubled times there ought to exist at the seat of Government a great, subtle, vague, undefined power pervading the whole country, reaching through all the ramifications of the telegraphic system, which will enable him, while seated in his office, by a dash of his pen, to set the electric fire in motion, and to order arrests at Cincinnati, at Chicago, at Baltimore, or even in Connecticut, where there is no treason, but too much love of peace."

"Sir, I do not believe in the necessity of any such power, lawfully claimed or unlawfully claimed. I do not believe that it is necessary to the management of this war. I do not believe that it promotes the purposes of those who desire to see this Union brought together again—an object of all others to me the most

desirable if it be possible. I believe, on the contrary, that it disaffects a great many good and worthy men who desire to see the Union restored. This, sir, I do know, that if there is no power in the Constitution to authorize these arrests, and if this body shuts its eyes and closes its ears to all complaints on that subject, the day is not far distant when the vital spirit of a republican government will be entirely gone from us.

"Sir, I thank the Senator from Illinois, and the Senator from New Hampshire, for the just and noble sentiments they have expressed to-day, and I shall lament in despondency and grief if the Senate shall shrink from an inquiry so obviously (to me at least) proper as this."

Mr. Wilson, of Massachusetts, said: "Sir, when these arrests were made, by the authority of the President of the United States, first through the Secretary of War, and afterward, by arrangement, through the action of the Secretary of State, the loyal people of this country were electrified; they felt that they had a government that was ready to exert its power to save the country, and they rejoiced as they did when Mason and Slidell were clutched from the deck of a British vessel, and imprisoned at Fort Warren, under the direction of the Secretary of State. The people of the loyal States have expressed, in every form in which they could make their sentiments known, their approbation of these arrests.

"I should have no objection to the passage of this resolution if it could do any good, but if senators are opposed to these arrests altogether, say so; if they are in favor of these arrests, but believe that this is not the proper mode, then let them come into the Senate with a bill, and I think we shall all vote for a proper measure of that kind, and so arrange it that disloyal persons may be arrested according to the forms of law. That I think is the proper way; it carries no censure, it implies no reflection on any one; but I think the adoption of this resolution, especially after the remarks that have been made here to-day, will be regarded as a reflection upon the President and upon the Secretary of State; and, if it is so understood, traitors whose mouths have been closed during the last four or five months, will again open their treasonable lips, and Jefferson Davis, and the men who are supporting his rebellion, will express their joy, if they do not vote their thanks to the American Senate for thus reflecting upon their own government."

Mr. Trumbull again replied: "I have already stated that this is not a resolution to censure the Administration. Who makes it a censure on the Administration? Who seeks any such issue? The Senator from Massachusetts is trying to make such an issue. I have quite as high a regard for the Administration as he has. I stated the object of the resolution. It is a resolution of inquiry, and I have not even said that arrests had been made; but if there is no authority to make them, and it is necessary they should be

made, we want to pass the necessary law. The Senator from Massachusetts goes off, in his zeal, to denounce traitors. He is no more against traitors than I am, but I am for constitutional liberty and against traitors too. He is against traitors and against the Constitution of his country, and that is the only difference. I will put down treason and save the Constitution, save regulated liberty, and he does not care whether there is any Constitution or not. I am not to be put in such a position. The Senator shall make no such issue with me—that the resolution is introduced as a reflection on the Administration.”

Mr. Latham, of California, said: “I see no necessity for trampling upon the Constitution in order to maintain it. I see no necessity for violating all law, and by our refusal to pass this resolution acquiescing in and endorsing usurpation of power, in order to preserve the laws. We present to the civilized world a very sad and humiliating spectacle, in upbraiding revolting States for violating the laws and the Constitution, when we ourselves are committing equal if not greater outrages upon that Constitution and against those laws. What is it? One man, unauthorized by the Constitution or the law, usurps the power to arrest the citizen, to incarcerate him, to discharge him or hold him in prison upon the tenure of his will, without the courts, Congress, the people, or anybody knowing the reasons for this usurpation.”

Mr. Fessenden, of Maine, then presented his views, as follows: “I have no question, indeed I know, that, under the directions from the Secretary of State, certain individuals in the loyal States have been arrested and imprisoned. That is notorious; the whole country is aware of it. I will say here that I do not believe there is the slightest warrant of law for any such proceeding, and I do not suppose you will find a lawyer in the country who does think there is any warrant of law for any such proceeding; and yet I do not shrink from it. For the most part, so far as I know in the great majority of cases, certainly wherever the necessity existed—and I shall not undertake to judge as to that—I justify the act, although it was against law; I justify it from the necessity of the case, and especially in the instances referred to by my friends from Maryland. I will not say in all of those instances, but in many of them; for I am not aware of the facts in all the cases. There are others equally notorious. Why do I say that I justify it? Because, in my judgment, it was absolutely necessary to the protection of the commonwealth, if I may so call it—the Government of the country. It was the business of the Administration, under the circumstances, to see that no detriment was done to the Republic, and where they acted, believing conscientiously that the good of the country demanded this action in this the hour of her peril, although they may have acted against law, I honor the man who, under such circumstances, takes the responsibility;

and I say here that if I were in power as an executive officer, and if I saw that the good of the country that I was serving demanded that I should stretch my authority, even at the risk of my official or of my own natural life, in order to protect the country, as God is my judge, I would do it, and take the consequences; and it is the duty of every man placed in such a trust to do it. A man who stops, who hesitates, in such a case to inquire, when he sees that the building is about to be wrapped in flames, whether there is a law to guide his action, and pauses for fear that the newspapers may be down upon him, or that he may be called to account, that he may be impeached even, is unfit for a great place.

“That is my opinion; but, sir, while I express that opinion, I say that when he steps beyond it, when the people see, or the representatives of the people see that he is daring for a moment to use that power and that pretence of necessity for a nefarious purpose, for any purpose that is not fully justified by the facts before him—when the country sees, or believes, or dreams, or suspects that he is acting from anything but the highest motives that should actuate a public officer, then I would be ready on the instant to check the first advance, and to lay my hand upon the man.

“Sir, we cannot trifle with these questions in times like those that have preceded the present moment. There have been hours, there have been days, weeks, and months in the progress of this rebellion, when it was the duty of the Executive to act promptly, without fear, without trembling, at their own risk and the risk of public reprobation; and when they did it from good motives and took that responsibility, it only showed them in my judgment so much the more fitted for the exigency which is upon us. But, sir, I agree with my honored friend from New Hampshire, I agree with my friend from Illinois, and others, that we should watch carefully, most carefully, the first approach to any exercise of illegal power that is not fully justified by the pressing exigency of the hour, because it has been well said, and is known as a principle which every man certainly of us must recognize, that we, standing here as the guardians of public liberty, must see that no man infringes on the liberty of the citizen, unless under such circumstances that all the world will justify him from the obvious necessity that requires the act.”

Mr. Browning, of Illinois, opposed the passage of the resolution chiefly because it was an inappropriate time to adopt it. He said: “I regard the time at which the inquiry is proposed as the most inopportune that could possibly have been selected. At a time when the energies of every department of the Government are taxed to their utmost capacities and powers of endurance to meet and put down a formidable rebellion, threatening the very overthrow of the Government, and at a time when we are probably on the very verge

of a rupture with one of the most powerful nations of the earth, whose power is to be united with that of the rebels in the fierce struggle with us, I think it would be far better for us to expend our time and our energies in devising the means for the successful prosecution of the war, and the suppression of the rebellion, than to waste it in what will have the appearance, whether it is so in fact or not, and make the impression over all the country of an assault upon the Administration."

Mr. Trumbull, of Illinois, replied to this objection, saying: "My colleague further says that this is a bad time to offer such a resolution. Why, sir, it is the only time when there would be any occasion for such an inquiry. It is in just such times as these that this power is exercised. It is only on such occasions as this, I know, that he would attempt to justify it. In a time of quiet and peace in the country he would not agree that men should be arrested without charge, without complaint, without opportunity to answer. From necessity, if you ever make the inquiry, you must do it now."

"He says, moreover, we give aid and comfort to the enemy by this resolution. Sir, I disagree with him totally. If you will have a united people, if you will bring up the twenty millions of loyal people in this country as one man to crush out this wicked rebellion, you must bring them up believing they are fighting for constitutional liberty; you must bring them up believing they are fighting for law, and to maintain the institutions which are established by the Constitution; and you will weaken your Government, you weaken its hands when you do anything that creates the impression in any portion of the country that we are not fighting for this regulated liberty."

The resolution was referred to the Committee on the Judiciary.

YEAS.—Messrs. Anthony, Browning, Chandler, Clark, Collamer, Cowan, Dixon, Doolittle, Fessenden, Foot, Foster, Harris, Howe, Johnson of Tennessee, King, Lane of Indiana, Morrill, Pomeroy, Rice, Sherman, Simmons, Sumner, Ten Eyck, Wade, and Wilson—25.

NAYS.—Messrs. Bayard, Bright, Carlile, Grimes, Hale, Harlan, Kennedy, Latham, McDougall, Nesmith, Pearce, Powell, Saulsbury, Thomson, Trumbull, Wilkinson, and Willey—17.

On the 16th of December, a bill was brought before the House to authorize the raising of a volunteer force for the better protection of Kentucky. The objections advanced against this bill were that the measure was uncalled for—that there were more soldiers in the field than were necessary, &c. These objections were urged by members who asserted that slavery was the cause of the troubles of the country, and who feared that if this extra force in Kentucky, composed of citizens of the State, was authorized, it might serve as an additional protection to the institution of slavery in Kentucky. Mr. Lovejoy, of Illinois, opposed its passage. He said: "I am willing to vote all

the men and all the money that are needed in defence of the country, and in defence of true and loyal men anywhere within the limits of the United States; but I insist that we have more soldiers now than can be used. If we have sixty thousand soldiers in Kentucky and thereabouts, advancing, and we need twenty thousand more to protect them as they march, or to keep the line of communication, twenty thousand more can be ordered from the Potomac, or from some other quarter, for I do not know where all our soldiers are now."

Mr. Richardson, of Illinois, replied: "I hope this bill will pass, sir, and I will state to my colleague why I think it ought to pass: They propose to raise twenty thousand troops in Kentucky who are familiar with all the country there; and the misfortune that has attended us heretofore has been that we have not been familiar with the country where we have had to fight. There are some limitations upon the raising of this force. They are to serve in Kentucky. They will make the most efficient soldiers there. Our base of operations has got to be at Louisville. Twenty thousand troops are necessary in order to guard our base and guard the line that you have got to advance as you go into the rebel States, and these are the best troops that you can get to guard that base, and to guard that line."

Mr. Wickliffe, of Kentucky, followed. He said: "What is proposed by the bill under consideration? It is, that when the main army gets ready for its operation on Columbus, and to open the navigation of the Mississippi river, the rear of the army shall be protected, and the people and homes of Kentucky defended from inroads from Tennessee and Virginia, on these seven hundred odd miles of border line. We think we will not want this force longer than twelve months, and that we can raise them—suitable, ready, and prompt, to perform that service. We do not say that they shall not serve their country anywhere else. If the commanding general deems it necessary that they shall be moved elsewhere, they will fight wherever an enemy is to be found; and I will guarantee that they will do it well, and will not stop to inquire whether they must cross the line."

Mr. Stevens, of Pennsylvania, objected to the passage of the bill on the ground of economy: "I think that if this House mean that the war shall be carried on to a successful termination, it must be done in such an economical manner as that the people shall not become alarmed, and that it shall not have to be abandoned before it is finished. The only way to guard against that is to use economy, and to restrain the expenditures of the Government within all possible bounds, consistent with carrying it on properly."

"Now, sir, the House ought to know something about what it will be called upon to appropriate, according to the estimates sent to us. The Committee on Ways and Means will

have to report a deficiency bill, even after Congress appropriating \$318,000,000 last July. We shall have to appropriate from one hundred and sixty to two hundred and fourteen million dollars more to make up the deficiencies for this fiscal year. We shall also have to report a bill making an appropriation of \$418,000,000 for next year. We will thus have to appropriate more than six hundred million dollars, without the addition of a single dollar beyond what is estimated for. Now, sir, that in itself is alarming. I confess I do not see how, unless the expenses are greatly curtailed, this Government can possibly go on over six months. If we go on increasing expenses, as we have been doing, and as we propose to do by this bill, the finances, not only of the Government, but of the whole country must give way, and the people will be involved in one general bankruptcy and ruin.

"Now what does this bill propose to do? We have already in the field an army of six hundred and sixty thousand men. I am told that eighty thousand of these are in Kentucky, constituting the command of Gen. Buell. If that be not enough, it is most remarkable that, out of the six hundred and sixty thousand now in the field, enough cannot be spared to guard Kentucky."

Mr. Diven, of New York, replied: "Mr. Speaker, I wish to advert briefly to the argument employed by the gentleman from Pennsylvania (Mr. Stevens) against this bill—that is, in reference to the enormous expenses that this country is incurring, and his unwillingness to add to that expense under any contingency. Sir, this country is advanced too far in this war to recede. It will not do to make calculations as to whether the expenses now running against the Government can be endured for two or three years. The expenses that are rolling up daily and monthly must be terminated? How terminated? By withdrawing our troops, disbanding our armies, and giving up this struggle? Who would thus terminate this expense? No, sir, that is not the way. There is but one determination as to the manner in which this expense shall be abridged. It is by going through with what we have undertaken. This rebellion must be put down, and put down speedily, or it will wear out the resources of the country. In deciding, therefore, whether I will vote for this additional expense or not, I will be controlled by the fact whether this rebellion will sooner be put down by my giving than by my withholding my vote. Let it be made apparent that by this additional force in Kentucky this rebellion can be subdued one month sooner than by withholding it, and it can be shown that no better economy can be employed than by the expenditure of this money in Kentucky."

Mr. Wright, of Pennsylvania, urged the passage of the bill at some length, during which he alluded to the object of the war in these words: "Sir, if this war is conducted upon

legitimate principles, I have no fears in regard to its result. If you will confine yourself to the proclamation of Abraham Lincoln, issued on the 19th of April last, when he made his appeal to the people of this country, saying that he wanted an army to put down insurrection and rebellion, and to protect the rights of property and the rights guaranteed by the Constitution to the States—if gentlemen will but adhere to the principles contained in that proclamation, there is no danger with regard to the result of the war, with the number of troops we now have in the field. But if it be the desire and the plan to change the object of the war, and make it a war for emancipation, I can tell those gentlemen who hug the negro so closely to their bosoms that they do it at the hazard of the very life and existence of the Government itself. I do not pretend to say whether the gentleman from Illinois be of that party or not. If gentlemen will confine themselves even to the principles of the Message which the President sent in at the opening of this session, we need have no fear with regard to the result; but, as the gentleman from New York (Mr. Steele) observed the other day, I repeat, if you change the object and principle of the war, you paralyze the bravery of the army; you present another question; you present a divided North and a South united. That would be the effect of such a change of policy. It is a war for the supremacy of the Constitution and laws, and the honor of the flag, and not for the emancipation of slaves. I believe that it is the sworn duty of this Government to accept all the men who offer to come to our standard for that purpose, as these twenty thousand men seek to enlist under our standard in Kentucky, and to make our ranks formidable. I believe that we already have a well-disciplined army."

Mr. Hickman, of Pennsylvania, opposed the bill on the ground that it was giving to Kentucky a military system different from that in the other States, and thus replied to the remarks of the preceding speaker on the conduct of the war: "My colleague (Mr. Wright) has resorted not to argument, but to a declaration which I had hoped might have been avoided upon this floor. It is to this amount: that if this army should at any time be used, as I understand him, under any circumstances, to free negroes from slavery, you will have demoralized the army and imperilled the safety of the country. I enter my protest here against the truth or soundness of any such declaration. It is placing negro slavery above the country. It is making the salvation of slavery superior to and more sacred than the safety of the Constitution of the country. Sir, in my judgment, that man is not fit to conduct this war, either as chief Executive or as a member of the Cabinet or as Commander-in-Chief or as subordinate officer, who does not place the safety of the Constitution beyond and above, immeasurably beyond and above, the safety of negro



slavery. Whenever that sentiment shall predominate in the United States, as uttered by my colleague, then American liberty will sleep forever. There is but one sentiment which an American patriot can own: that is, that the American Constitution, the American Union, and American institutions, are superior to and above everything else, including local institutions of a peculiar character or the safety of any local people."

Mr. Bingham, of Ohio, met the objection against the merits of the bill by the following statement: "The bill in no respect differs in principle from a previous bill passed by this House on the 22d of last July, and which received the assent both of the gentleman from Pennsylvania and of my worthy friend from Illinois. This bill is as well guarded as that was, touching the objects and purposes for which these volunteers may be called into the field. That bill contains the same phraseology under which my friend from Illinois (Mr. Lovejoy) thinks is lurking a power to strike at the rights of the slave. The declared purpose of that bill and of this is, that the volunteers are to be used 'for suppressing insurrection, repelling invasion, and protecting the public property.' These words are used in the same sense in each of the bills."

Mr. Lovejoy, of Illinois, said: "I wish to ask the gentleman why it is necessary to raise this number of men, when we already have enough to perform the service; when we have ten thousand, at least, waiting in Illinois, and anxious to get into a fight somewhere?"

Mr. Bingham replied: "The difficulty is that I do not know that the fact is as it is stated by the gentleman from Illinois. On the contrary, I have the best evidence that the force in the field is not sufficient for the public interest, and therefore I am for the proposed increase."

Mr. Lovejoy, of Illinois, again rose and said: "I would like to know upon what facts the gentleman states that we really need more soldiers in the service of the United States?"

Mr. Bingham replied: "If the gentleman wants some authority, I will say that we have the report of the Adjutant General of the United States, stating that the whole force in Kentucky is not more than one third of what our public exigencies require. We have also the statement of the representative from Kentucky (Mr. Wickliffe) that the Secretary of War himself stated that this additional force of twenty thousand is needed now in the service in Kentucky."

Mr. Wickliffe, of Kentucky, repeated his previous statements. He said: "I stated that, before I received the communication from the Legislature of Kentucky, urging the organization of a force of this kind by the General Government, I had consulted the Secretary of War upon the propriety of it, and explained to him the purposes, objects, and necessity of the corps. He approved of it, or else my ears de-

ceived me. I then went to the President of the United States, and submitted the proposition to him. He took it under consideration, and told me he would consult his cabinet. He afterward informed me that he approved the raising of the troops, that he believed them necessary."

Mr. Maynard, of Tennessee, urged the importance of the bill. He said: "I have not attended sufficiently close to the movement of this debate to know how the negro question has been introduced into it; but I cannot see how it properly has any connection with it. I suppose there are very few gentlemen—certainly I hope there are but few—upon either side of the House, who do not concur in the general sentiment that the preservation of this Union and the perpetuity of our American nationality is an object infinitely more important for us to consider than either the preservation of slavery or the abolition of slavery. We are told that this legislation is peculiar; that it is abnormal. In answer to that it is sufficient to state that the condition of Kentucky at this time is peculiar. Kentucky occupies a peculiar situation in connection with our public affairs. She is not only invaded by armies in large force and great strength, but she has the elements of disorder within her own limits. She has, in portions of the State, a large number of latent rebels who are very strong in their sympathy with those in active rebellion against the Government, and who are only waiting a fit opportunity to let their sympathy break out in open insurrection. She is surrounded by hostile forces on three sides, who wish to make her Union and loyal citizens feel the force of their wrath in consequence of the attitude of loyalty they have assumed toward the Government. Hence she is subject to invasion from those quarters. Her railroads, her bridges, and her other public property are in constant danger of being destroyed; and this not by the regular movement of armies and large bodies of men, but by guerilla bands who come in the night and go in the night; who go in small numbers by stealth through the byways of the country. In order to defeat them, you do not want armies, but bands of men equal in number and firmness of purpose to them. You want men familiar with the country; who have that sort of local knowledge which will enable them to meet this invading or insurrectionary force. It is manifest that such men must be drawn from the country itself, and that their organization should be in the nature of a police force, to preserve order and give protection to the people at home.

"Now, the State of Kentucky, as has been repeatedly said, has already furnished her quota of troops for the armies of the country. She has, if I mistake not, a larger force in the field for the war than the State of Massachusetts, with her larger and entirely loyal population; yet her resources in the way of raising troops are not exhausted. It does not follow that

because she has already furnished nearly thirty thousand troops for three years, as we have been told she has, she cannot furnish half as many more. It is believed that, for a more limited period, and for the special purposes designated in this bill, she can and will furnish more. I need not say that there are many men who could go into the service for twelve months who would find it inconvenient, if not impracticable, to enlist for three years. If it is admitted that it is the duty of the Government to give protection to loyal citizens who have attested their loyalty to the country by as great sacrifices, at least, as the citizens of any part of the country, I see not how we can hesitate a moment about the passage of this bill. These men must be protected. It is a duty which the Government owes them."

Mr. Blair, of Missouri, rose and replied to the statement that the force was not needed. He said: "Mr. Speaker, I merely desire to occupy the attention of the House for five or six minutes in concluding this debate; and I want especially to reply to the remarks made by the gentleman from Illinois (Mr. Lovejoy), who first spoke in opposition to this bill. He asserted over and over again that this force is unnecessary, and that we have more troops than we want, and do not know what to do with them. Now, I would reply to that remark by saying that we have the best reason in the world for believing that we have not got enough men in the field, for we have not been able to conquer this enemy anywhere as yet. That is one proof of it, and another proof of it is that we never have met them anywhere that they have not outnumbered us. We have never confronted the enemy in battle yet when they have not been superior to us in numbers, and we have never been able to drive them back one foot. I think that that ought to be proof conclusive to the gentleman from Illinois that we have not got enough men."

Mr. Lovejoy, of Illinois, in reply, said: "I suppose that fact is accounted for by this, that the enemy never will meet us unless they are superior in numbers. They watch their opportunity, and never meet us on an equal field with equal numbers."

Mr. Blair answered: "Then why does not our army advance and overrun them?"

Mr. Lovejoy again replied: "Because we have no generals."

Mr. Blair responded: "Mr. Speaker, these gentlemen who insist all the time that we have got more men than we want, ought to be made to look the facts in the face. We have not as many men here—though the gentleman is complaining of being overrun in the city of Washington—as the enemy have in their breastworks on the other side of the river."

Mr. Hickman, of Pennsylvania, now rose and said: "I wish to ask the gentleman from Missouri how it comes, then, that this Administration is derelict in its duty in not asking Congress to raise more men."

Mr. Blair replied: "I do not know that the Administration is derelict; I rather think the gentlemen who refuse to vote troops are derelict."

Mr. Hickman responded: "That was not my question. I wish to know of the gentleman from Missouri how it is that the Administration is derelict in duty in this respect; why do they not ask Congress to raise more men? If we have not yet a number sufficient to conquer the enemy, then it is the plain duty of the Administration to ask us to vote more men; but they have not done so. This measure comes upon the recommendation of the Military Committee alone."

Mr. Blair again said: "Let me say to the gentleman from Pennsylvania that if the Administration is derelict, as he argues, that is no reason why we should be so; and when we see the fact as plainly as the Administration can see it, or as anybody else can see it, that our armies are not advancing, and that we have never met the enemy except when the enemy were in overwhelmingly superior numbers; when that is the undisputed fact before the country, we are ourselves derelict in duty if we do not vote additional troops."

"Now, sir, let me reply to another question which the gentleman from Illinois (Mr. Lovejoy) asked of the gentleman from Pennsylvania (Mr. Wright,) and that was, whether he was willing to accept all the men who would offer their service in this war? I say I would—every man. It would end the war quicker and more cheaply, in my opinion. I think the objection of the chairman of the Committee of Ways and Means (Mr. Stevens), that this is an expensive measure, and that our Republic is to be crushed by the expense of this war, is invalid. I believe that the more men we raise the more speedily will we end this war, and the more cheaply, too. I should have been in favor of doubling the number of men we have raised, and putting them in the field; and if it had been done sooner, in my opinion we should have felt the advantage of it now."

The bill was then read a third time and passed the House, but failed to pass in the Senate.

The subject of a reduction of the army came up also in the Senate, on the 28th of March. Mr. Grimes, of Iowa, moved that the Committee on Military Affairs and Militia be discharged from the further consideration of the following resolution:

*Resolved*, That in the opinion of the Senate no persons should be commissioned as generals of divisions or brigades except such as shall exhibit superior competency in the command of men, or gallantry in action against the enemy.

Mr. Grimes thus stated the object of the resolution: "I merely desire to get it before the Senate in order that we may put it in the proper form, and then express to the country and to those who have the authority to appoint general officers in the army, what are our con-

victions as to the proper course to be pursued. I wish the Senate and the country to know that at this time there have been appointed one hundred and eighty brigadier generals in the United States Army—one hundred and seventy-two irregular or volunteer brigadier generals and eighty brigadiers in the regular army. The pay of these officers is \$3,954 a year, including their legitimate pay proper and a portion of the commutation of their rations; but in addition to that, they draw upon an average, as I have learned by investigation, a commutation for quarters amounting to \$300 each, a commutation for fuel amounting upon an average to ninety-six dollars each, a small commutation for lights; and besides they receive medical attendance, drugs, medicines, and stationery free. I think it safe to say that the expenses to the United States growing out of the appointment of brigadier generals alone is \$1,000,000 a year.

"Now, sir, I am prepared to say, and I think the facts justify me in saying, that the necessities of the army and the country do not require one half of this number of brigadier generals. We went through the Mexican war with only three generals in the field. Brigades and divisions were then commanded by colonels. Regiments were commanded by captains. In some instances regiments were commanded by first lieutenants. They acted bravely; they vindicated the honor of the country; they upheld the honor of its flag upon every field. The comparative expense, therefore, of conducting that war with officers enjoying those ranks was nothing at all by the side of the expense that we are now incurring."

Mr. Wilson, of Massachusetts, said: "I concur with the Senator from Iowa in the opinion that we have had quite enough general officers nominated. Still, sir, I think the Senator is somewhat mistaken in some of the views he has expressed. We have in the field something more than six hundred regiments, making one hundred and fifty brigades, and, of course, they require one hundred and fifty brigadier generals. We have forty-five or fifty divisions of the army, and they require so many general officers. Then we have several departments or *corps d'armées* in the service, which require some ten or fifteen general officers. We have had nominated one hundred and seventy-five brigadier generals for the volunteers, and about twenty major generals. I believe the one hundred and seventy-fifth brigadier general was nominated this morning, and his name will be down here by and by. A few of these nominations, I believe, we have rejected; a few more I certainly hope we shall reject for the good of the service and the credit of the country."

Mr. Fessenden, of Maine, followed saying: "It is absolutely necessary, in my judgment, that Congress should bring itself to consider the question of expense, and as well with reference to their own particular friends as to anybody else. They should remember that the

country has to pay for it, and that we should not have any more of these gentlemen appointed, if we can help it, than are necessary in order properly to command the army. It is not for me to say how many may be necessary; but let the gentlemen look at the question for a moment. My honorable friend from Massachusetts says there are so many brigades in the army. We all know there are a great many more than Congress ever intended there should be; that we intended in the beginning, and we so legislated, that the number of volunteers to be raised should be limited to five hundred thousand; but although Congress in its language expressed the idea, and it was stated so over and over again, it accidentally gave a power which extended to a million, or was so construed as to extend to a million, and under that our army has been swollen up to over seven hundred thousand men. At this day I do not think a man can be found anywhere who will say that half a million are not all that we can possibly need or use; and yet we have this number of troops in the service, though not actually in the field. There are regiments in my own State to-day that have been raised, staying there—who have been staying there for months—paid by the Government, efficient men, the choice men of our State, waiting and begging to be called into the field and not to be left there doing nothing; not armed; ready to do everything, anxious to be in service; and the answer is: 'We have no occasion for you; we have got so many men here—more than we know what to do with;' men who make a most elegant appearance on days of review, and who undoubtedly would fight well if they could only get a chance. There are more men than the Government knows what to do with here on the Potomac to-day. What occasion is there to send for others? So it is in every State in the Union; there are men who are paid from month to month, and who have been paid for months, not armed, not called into the field, absolutely for the reason that the Government has no occasion to use them; and yet no step is taken to disband these men. Why not disband them, if they are not wanted? Because we have seven hundred and fifty thousand, if that is the number—two hundred and fifty thousand more than we ever intended to have—therefore my friend from Massachusetts argues you must have a number of generals to correspond! I dare say we have more brigadier generals to-day than there are brigades organized. What is the reason why we should go on and appoint generals to correspond with a number of men that are not needed and are not used? It is extravagance of the most wanton kind; and we may as well express our opinions upon it openly and let the country understand it. I mean to wash my hands of it. I have tried to do so here over and over again repeatedly. I offered a proposition the other day to stop all enlistments until the army should be reduced to the proper level, until we should get down to the number

we wanted, and no more. My friend from Massachusetts said we should have a bill soon where I could put on my amendment. I have not seen his bill yet; as soon as he brings it along so that I can put on my amendment I will, and I hope it will be forthcoming very soon. I understand, however, that the Department has absolutely stopped enlistments; but whether that be so or not, it is best to reduce it to shape and have a law on the subject. The country is ready to raise, I am ready for my constituents to say and we will all say that they will raise, whatever number of men may be needed, and put them in the field, and set them to doing the work we want done; but why should we saddle the country with a quarter of a million of men more than are needed, and simply for no other reason than because A, B, C, D, E, and F, and so on through the alphabet, are continually pressing for authority to raise men who are not needed? I for one thank my friend from Iowa for introducing this resolution, for if it has no other effect it gives an opportunity for those of us who desire to do so, to express to the country our anxious wish to stop this wanton waste."

Mr. Wilson, of Massachusetts, replied: "The Senator from Maine the other day proposed to reduce the number of men authorized by law down to five hundred thousand. I agree with him in that. Still we have not been able to do it. It was suggested also that we ought to stop recruiting. I agree to that; I have over and over again been to the War Office and urged upon the Department to stop recruiting in every part of the country. We have had the promise that it should be done; yet every day in different parts of the country we have accounts of men being raised and brought forth to fill up the ranks of regiments. The papers tell us that in Tennessee and other parts of the country where our armies move, we are filling up the ranks of the army. I believe we have to-day one hundred and fifty thousand more men under the pay of the Government than we need or can well use. I have not a doubt of it; and I think it ought to be checked. I think the War Department ought to issue peremptory orders forbidding the enlistment of another soldier into the volunteer force of the United States until the time shall come when we need them. We can obtain them any time when we need them.

"Then, sir, there is another thing that ought to be done; and I have pressed that on the War Office for weeks; and I suppose they are trying to do it; for I want it to be understood I make no complaint of the manner in which business is done in that office. They have a great deal to do, and a great deal must necessarily escape their attention. It is this: we have thousands of men in the volunteer force of the country unfit for duty. I know regiments that have moved down the river that have left forty and fifty men behind them about Washington who want to be discharged and

who ought to be discharged, and who would be discharged if the medical men would attend promptly and vigorously to their business. We have in this army, with a great deal of energy and vigor, a great deal of this how not to do a thing. I think we have a great deal of that in that portion of the army. We have thousands of men who ought to be discharged from the Army of the United States, for they are physically unfit to bear the burdens of a campaign, and most of these men desire to be discharged.

"Now, sir, the Senator from Iowa thinks it will be difficult for us to get rid of these generals. We make them easily. I do not think, as a general rule, any difficulty will grow out of making them, more than other officers. I think we shall get rid of them just as easily as we make them."

The motion to discharge the committee was not agreed to.

In the Senate, on the 18th, Mr. Sumner, of Massachusetts, offered the following resolution:

*Resolved*, That the Committee on Military Affairs and the Militia be directed to consider the expediency of providing by additional legislation that our national armies shall not be employed in the surrender of fugitive slaves.

He said: "Sir, besides my general interest in this question, besides my interest in the honor of the national army, I have a special interest at this moment because Brigadier General Stone has seen fit to impose this vile and unconstitutional duty upon Massachusetts troops. The Governor of my State has charged me with a communication to the Secretary of War on this subject, complaining of this outrage, treating it as an indignity to the men, and as an act unworthy of our national flag. I agree with the Governor of Massachusetts; and when I call attention to this abuse now, I make myself his representative, as also the representative of my own opinions.

"But there are others besides the Governor of Massachusetts who complain. There are two German companies in one of the Massachusetts regiments who, when they enlisted, entered into the public service with the positive understanding that they should not be put to any such discreditable and unconstitutional service. Sir, they complain, and with them their own immediate fellow-citizens at home, the German population generally throughout the country. I am glad to know that my friend and colleague, the chairman of the Committee on Military Affairs, promises us at once a bill to meet this grievance. It ought to be introduced promptly, and to be passed at once. Our troops ought to be saved from this shame."

Mr. Cowan, of Pennsylvania, followed. He regarded the cause of the mischief complained of as arising from the injudicious proclamations of various Generals, but apprehended that there need not be any difficulty upon the question. Alluding to the views of the people of Pennsylvania, he said: "There is a tendency on the

part of a great many people in the South to insist that this war is to be a war for the emancipation of their slaves, and there is a tendency on the part of a great many people in the North to insist the same thing. Now, sir, I speak for Pennsylvania, the great State, the Keystone State, which lies between these extremes, and where we think we can look upon this question as coolly as it is possible for a disinterested person to examine anything. I say for her that she repudiates both these extremes. Her object, when she put her one hundred and five thousand or one hundred and six thousand men into the field upon which this battle is to be fought, was not that. Her object was to vindicate the Constitution and the laws, and to compel obedience to them everywhere, uncaring consequences. If in the flames of this war the chains melt from the slave, it is not her fault. They who lighted up the conflagration are alone responsible, and upon them let the responsibility rest. The object which she pursues is that one which I have stated, and that one alone. She has always at all times joined most heartily in indorsing that amendment to the Constitution which was passed here at the last session, and declared that she desired to interfere in no wise with the domestic institutions of any other State."

The resolution was agreed to.

A short time after hostilities commenced between the North and the South, an order was issued from the State Department, requiring passports to be procured by all persons intending to depart to foreign countries. Persons going to California were also included in this order. It led to a call by Congress upon the Department for an explanation.

Mr. Latham, of California, offered the following resolution:

*Resolved*, That the Secretary of State be requested to inform the Senate by virtue of what law, or for what reason, passports are required of passengers going direct from New York city to San Francisco, in California.

He said: "Mr. President, this is simply a resolution of inquiry, and I desire to state to the Senate that, in offering it, I had no intention to embarrass the Department of State. Neither do I propose, by making the inquiry, to do anything more than what I conceive is justice to the people that I have the honor in part to represent upon this floor. The people of California have a right to know why those of them, who are going to the West and returning to their friends in the East, are subjected to this imposition. They have a right to know by virtue of what law or for what reason it is done. I say it is an imposition, because the people of California are the only people in the Union among the loyal States that are now paying for the privilege of going to their home and of leaving it. I do not know, sir, by what right the Secretary of State can exact from the people of the Pacific coast the taking out of a passport, any more than he can of the citizens

of Massachusetts who want to leave that State and go to the State of New York."

On a subsequent day the Secretary of State, Mr. Seward, sent the following letter to the Senate:

*To the Senate of the United States:*

The Secretary of State has the honor to acknowledge the receipt of the resolution of the Senate of yesterday, requesting him to inform the Senate by virtue of what law or for what reason, passports are required of passengers going direct from New York city to California. In reply, the Secretary of State has the honor to remark, that the twenty-third section of the act of Congress of the 18th of August, 1856, ordains, "that the Secretary of State shall be authorized to grant and issue passports, and cause passports to be granted, issued, and verified in foreign countries, by such diplomatic or consular officers of the United States, and under such rules as the President shall designate and prescribe, for and on behalf of the United States."

From the beginning of the insurrection there has been reason to believe that citizens of the insurgent States and agents of the insurgents have taken passage in the steamers from New York to Aspinwall for disloyal purposes, and especially for the purpose of embarking for Europe and elsewhere. Latterly, it was deemed imperative for the public safety to endeavor to check this practice. With this view, a few weeks since, the Secretary of State directed that all persons embarking in such steamers should obtain passports. These instruments are by law required to be gratuitously furnished in this country, and in order that travellers might experience as little inconvenience and delay as practicable in obtaining them, the Secretary of State authorized the despatch agent of the Department at New York to furnish them to loyal applicants in the same manner as if they should apply to the Department itself. Complaints of the inconvenience of the requirement, however, to travellers to California, having reached the Department, the regulation was for a time suspended; but information having been received that the suspension had led to abuses which it was the original object of the regulation to correct, it has been recently restored.

The Secretary of State is well aware of the importance of free communication between the Atlantic States and the possessions of the United States on the Pacific, and would, at all times, be reluctant in any way to trammel that communication. It is believed, however, that no loyal citizen will, under the circumstances, object to the temporary requirement of a passport. When the order referred to was restored, instructions were at the same time given to exempt from the requirement that class of passengers among whom dangerous conspirators against the Government and the Union would not probably be found.

WILLIAM H. SEWARD.

DEPARTMENT OF STATE,  
WASHINGTON, December 19, 1861.

It has been stated that the legislation of Congress assumed an entirely new aspect at this session. Much time was spent during the first half of the session, in discussing resolutions, which, although of no unusual importance, yet served to develop the views of individual members, to incite the ardent, to push forward the timid, and secure the cooperation of a majority for those strong measures which finally prevailed. As is usual in a revolution or civil commotion, while the vigor of a country is unimpaired, the extreme champions of the movement are at first successful. But when the exhaustion of the country intervenes, they are supplanted by those hitherto regarded as timid

conservatives. The first class now proceed to triumph in this session of Congress.

In the Senate on the 19th of December, Mr. Willey, of Virginia, offered the following resolution :

*Resolved*, That the existing war, forced upon the country by the instigators of the rebellion without justifiable cause or provocation, was, and is, designed by them to destroy the Union and the Constitution; and their purpose, moreover, was at first, and is now, to disavow and repudiate the fundamental principles of republican government on which our fathers established the Union and the Constitution.

Mr. Willey proceeded to address the Senate, and to show that there had been at the South no just cause of dissatisfaction with the Government. It had most successfully accomplished the end of its institution in securing "life, liberty, and the pursuit of happiness" for the citizen, and in "promoting the general welfare." The policy of the Government had always been controlled by the South, and at the time of the outbreak the administration of the Government was completely within the power of the South and its friends. Slavery and the rights of slaveholders were secure from any successful aggression by the Republican party or the General Government. No dread of the Abolitionists precipitated secession. He then presented his view of the primary inciting cause of secession. He said :

"But what was the primary inciting cause of this rebellion? I answer—dissatisfaction with the principles and operation of democratic government. It was hostility to the simplicity and equality of republican institutions. We may not find any direct and unequivocal avowal of this fact on the part of the conspirators. It would be strange if we should. Satan ever approaches his victims as an angel of light. Liberty has always been destroyed in the name of liberty. Despotism is strategetic. It fights with masked batteries. All history will attest that encroachments on human rights have generally been made in the guise of freedom and friendship.

"Mr. President, I am not before you either as the defender or the denouncer of slavery. Its friends, however, claim that it is necessary to the perfection of any high degree of civilization; that, by exempting those who possess slaves from those menial and servile offices inseparably incident to the economy of any condition of society, it affords leisure and means for superior mental and social improvement, and imparts a dignity of character and polish of manners unattainable where slavery does not exist. If this assumption be confined in its application to the slaveholder, it may, to some extent, be true; but how small a proportion of the people of the South own slaves!

"Sir, I dare not say, with George Mason, of Virginia, that 'every master of a slave is born a petty tyrant,' for I am a slaveholder. I despise the vituperation so indiscriminately heaped upon slaveholders by the madness of fanatic

abolitionists. They are the worst enemies of the slave in the world. They have already injured him much; and if their policy were carried out it would degrade the slave still below his present position, and entail miseries upon him exceeding the horrors of the slave ship. It would beggar both master and slave, and demoralize the whole country. Let us leave slavery where the Constitution and laws have placed it, and await the progressive influences of that blessed Christianity, which, in God's own time, shall redeem and regenerate the human race.

"But, sir, it may nevertheless be so that slavery does tend to foster in the feelings and mind of the slaveholder sentiments averse to the perfect level of natural and political equality upon which the system of American republican institutions is based. Labor is not so reputable in slaveholding as it is in non-slaveholding communities; and although the laws do not create or tolerate any distinctions predicated upon this fact, we find them existing with a power and influence as inexorable as if they were a part of the Constitution. I remember the startling effect of a passage in the speech which the eloquent Preston, sent as a commissioner from South Carolina to the late Virginia convention at Richmond, made before that body. Said he:

Southern civilization cannot exist without slavery. None but an equal race can labor at the South. Destroy involuntary labor, and the Anglo-Saxon civilization must be remitted to the latitudes from which it sprung.

"Sir, how I did wish that these remarkable sentences could have reached the ears of the five million laboring inhabitants in the South who own no slaves! Whatever may be the cause of this aristocratic sentiment in the South; and especially in the Gulf States, I shall leave the further discussion of it to philosophers and statesmen. It is the fact that I am at present considering; and that the fact exists is, I think, indisputable. It will not be denied that Judge Pratt, of South Carolina, is an eminently able man, and may justly claim to be considered an authoritative exponent of the views of a large portion of the people of his section. In a late elaborate article animadverting upon the temporizing measures of the confederate States, he says:

The contest is not between the North and South as geographical sections, for between such sections merely there can be no contest; nor between the people of the North and the people of the South, for our relations have been pleasant, and on neutral grounds there is still nothing to estrange us. We eat together, trade together, and practise, yet, in intercourse, with great respect, the courtesies of common life. But the real contest is between the two forms of society which have become established—the one at the North and the other at the South. Society is essentially different from government—as different as is the nut from the bur, or the nervous body of the shell fish from the bony structure which surrounds it; and within this Government two societies had become developed as variant in structure and distinct in form as any two beings in animated nature. The one is a society composed of one race, the

other of two races. The one is bound together but by the two great social relations of husband and wife and parent and child; the other by the three relations of husband and wife, and parent and child, and master and slave. The one embodies in its political structure the principle that equality is the right of man; the other that it is the right of equals only. The one, embodying the principle that equality is the right of man, expands upon the horizontal plane of pure democracy; the other, embodying the principle that it is not the right of man but of equals only, has taken to itself the rounded form of a social aristocracy. In the one there is hiring labor—in the other slave labor; in the one, therefore, in theory, at least, labor is voluntary; in the other, involuntary; in the labor of the one there is the elective franchise, in the other there is not; and, as labor is always in excess of direction, in the one the power of government is only with the lower classes; in the other, the upper. In the one, therefore, the reins of Government come from the heels, in the other from the head of the society; in the one it is guided by the worst, in the other by the best, intelligence; in the one it is from those who have the least, in the other from those who have the greatest, stake in the continuance of existing order.

“Mr. President, Judge Pratt is by no means singular in his repudiation of the cardinal principle of democratic institutions—the right of the majority to govern. The constitution of his State confines the political power, in fact, to a comparatively small number; and the fundamental laws of several of the other Southern States, including my own, have denied that population or suffrage is the true basis of political power, but secure to property a representation in the Legislature.

“Mr. President, Mr. Jefferson enunciated the axiom that ‘absolute acquiescence in the decisions of the majority was the vital principle of republics.’ Thus he summed up the argument in favor of adhering to the General Government and preserving it:

The preservation of the General Government in its whole constitutional vigor is the sheet-anchor of our peace at home and safety abroad; a jealous care of the right of election by the people—a mild and safe corrective of abuses which are lopped by the sword of revolution where peaceable remedies are unprovided; and absolute acquiescence in the decisions of the majority—the vital principle of republics, from which there is no appeal but to force, the vital principle and immediate parent of despotism.

“But, sir, Mr. Preston, the South Carolina commissioner, to whom I have already referred, delivered a very different message to us last spring, in the Virginia convention. He declared to us:

In the Free States, the simple, isolated, exclusive, sole political principle is a pure democracy of mere numbers, save a scarcely discernible modification, by a vague and undefined form of representation. In these States there can be no departure from this principle in its extremest intensity. The admission of the slightest adverse element is forbidden by the whole genius of the people and their institutions. It is as delicate in its sensitiveness as personal right in England, or slavery in Carolina; it is the vitalizing principle, the breath of the life of Northern socialism. The almighty power of numbers is the basis of all social agreement in the Northern States. A fearful illustration of this is at this moment exhibiting its results in the Government under which you are consenting to live. That Government was “instituted and appointed” to protect and secure equally the interest of the parts. By the

agency of mere numbers, one section has been restricted and another expanded in territory; one section has been unduly and oppressively taxed, and one section has been brought to imminent peril; and in this hour the people of the North are consulting whether they can subjugate the people of the South by the right of number.

The “government by the people” is equally the rule of the South, but the modification of the “rule of numbers” is so essential in the Slave States, that it cannot coexist with the same principle in its unrestricted form. In the South it is controlled, perhaps made absolutely subject, by the fact that the recognition of a specific property is essential to the vitalization of the social and political organisms. If, then, you attempt to institute the rule of either form into the organism of the other, you instantly destroy the section you invade. To proclaim to the North that numbers shall not be absolute, would be as offensive as to proclaim the extinction of slavery in the South. The element of property would neutralize the entire political system at the North; its exclusion would subvert the whole organism of the South.

“This is not the opinion of isolated individuals. It is wide spread in the South. It is already incorporated, in some form or other, in the organic laws of several of the States; and other States are seeking to give it constitutional authority. Thus, in the constitutional convention of Virginia, recently in session, Mr. Stuart, formerly Secretary of the Interior, as chairman of the committee having the subject in charge, made a report, from which I read the following extracts:

Governments are instituted for the protection of the rights of persons and property; and any system must be radically defective which does not give ample security to both. The great interests of every community may be classed under the heads of labor and capital, and it is essential to the well being of society that the proper equilibrium should be established between these important elements. The undue predominance of either must, eventually, prove destructive of the social system. Capital belongs to the few—labor to the many. In those systems in which capital has the ascendancy, the government must, to some extent, partake of the character of oligarchy; whilst in those in which labor is predominant, the tendency is to what Mr. John Randolph graphically described as “the despotism of king numbers.”

In the opinion of your committee no system of government can afford permanent and effectual security to life, liberty, and property, which rests on the basis of unlimited suffrage, and the election of officers of every department of the government by the direct vote of the people.

“Sir, great astonishment has been expressed at the hostility of Southern statesmen to popular education. But, sir, we ought not to be surprised at it. Knowledge is power; and to keep the masses in ignorance is a necessary precaution to keep them in subjection. To maintain the oligarchy of the few owning the capital, it is necessary to bind down with the slavish chains of ignorance the many who perform the labor. Hence Mr. Stuart connects with the recommendations which I have just read, the following:

This tendency to a conflict between labor and capital has already manifested itself in many forms, comparatively harmless, it is true, but nevertheless clearly indicative of a spirit of licentiousness which must, in the end, ripen into agrarianism. It may be seen in the system of free schools, by which the children of the poor are educated at the expense of the rich.

"Sir, the true reason of this hostility to popular education is hostility to democratic institutions. I need not remind many of the members of this body with what pertinacity Mr. Calhoun resisted the application of the majority principle to our system of national government, as subversive of the rights of the States." He warred upon this great principle from the time of his Fort Hill address, and before that time, down to the day of his death, in the Senate, in popular addresses, and in labored volumes of essays. Nor need I advert to the mighty influence which this great man exerted on Southern opinion. Sir, there is a widespread hostility all through the Gulf States, more especially, to the great fundamental political right of the majority to rule.

"It will be remembered, moreover, that the headspring of this rebellion was in the very State where, in the war of the Revolution, the attachment of the people to the aristocratic institutions of the mother country was the hardest to subdue. This attachment was never wholly extinguished. Flashes of the old aristocratic flame have often gleamed out from the revolutionary ashes, as they did recently, when Mr. Russell was assured by many there that they longed to renew their allegiance to some descendant of the royal family of England. Sir, there is a wonderful 'hankering' in South Carolina after the 'fleshpots of Egypt.' By referring to the January (1850) number of the Democratic Review, I find an elaborately written article, from which I have taken the following extract:

The formation of the cotton States, with Cuba, into a great cotton, tobacco, sugar and coffee-producing Union, calling forth the boundless fertility of Cuba, and renovating the West India Islands with the labor of the blacks of the Southern States, in those hands in which their labor and numbers have thriven so well, and THIS EMPIRE ANNEXED TO BRITAIN, by treaties of perfect reciprocity, giving the latter the command of the eastern commerce by way of Nicaragua, and all the benefits of possession, without the responsibility of slave ownership, would be a magnificent exchange for the useless province of Canada.

"And, sir, I find the following in the newspapers of the day, giving some most significant antecedents of the present distinguished Secretary of the Treasury of the so-called Confederate Government:

I was very much surprised, Mr. Chairman, at the honorable member's speech from Charleston (Colonel Memminger), who said he had rather South Carolina was attached to the Government of Great Britain, as she was previous to the Revolutionary war, than to remain a member of this Union. Such an expression neither becomes an American nor a Carolinian, and must have been uttered in the heat of argument and declamation, without due consideration.—*E. F. Perry, in the South Carolina Legislature for 1850-51.*

"In an address which this gentleman made before the Virginia Legislature a year or two ago, he uttered sentiments as little in accord with the spirit and genius of our American democracy.

"I recently cut from the 'National Intelligencer'—a paper which, by its wise, conserva-

tive, and patriotic course through a long series of years, has placed the friends of constitutional liberty under the most lasting obligations—the following short article:

**A NASCENT NOBILITY.**—In the number of *De Bow's Review* for July, 1860, is an elaborate article from the pen of George Fitzhugh, Esq., author of "Sociology for the South," and long a prominent advocate of disunion. In the article designated he gives expression to the following aspiration:

"England has once tried to dispense with nobility, and France twice, but each experiment was a failure. In America we have the aristocracy of wealth and talents, and that aristocracy is somewhat hereditary. The landed aristocracy of the South, who own slaves, approach somewhat to the English nobility. Time must determine whether the *quasi* aristocracy of the South has sufficient power, permanence, and privilege to give stability, durability, and good order to society. It is sufficiently patriotic and conservative in its feelings, but, we fear, wants the powers, privileges, and prerogatives that the experience of all other countries has shown to be necessary."

If such was Mr. Fitzhugh's fear while the South remained in the Union and under the Constitution, we presume his hopes have considerably risen since the outbreak of the present war, for in the same article he avows a preference for a military government, as being the "most perfect" known to man, and imputes it as a fault to the Republican party that the more advanced of its number were averse to wars. Mr. Fitzhugh's language under this head is as follows: [It will be seen that he finds the perfection of military government in the fact that it allows "the least liberty" to its subjects.]

"The most perfect system of government is to be found in armies, because in them there is least of liberty, and most of order, subordination, and obedience."

"It is but a short time since Governor Brown, of Georgia, charged upon the leaders of the secession movement in that State a design to establish

a strong central government, probably preferring, if they did not fear to risk an avowal of their sentiments, a limited monarchy, similar to that of Great Britain, or other form of government that will accomplish the same thing under a different name.

"Only two or three days before the victory of our fleet at Port Royal, Governor Pickens, of South Carolina, closed his message to the Legislature of that State with the following significant intimations:

As far as the Northern States are concerned, their Government is hopelessly gone; and if we fail, with all our conservative elements to save us, then, indeed, there will be no hope for an independent and free Republic on this continent, and the public mind will dependingly turn to the stronger and more fixed forms of the Old World.

In this point of view I most respectfully urge that you increase the power and dignity of the State, through all her administrative offices, and adhere firmly to all the conservative principles of our constitution.

"It were easy to multiply the evidence of hostility among the instigators of secession to what Judge Pratt calls the 'horizontal plane of pure democracy.' The columns of most of the leading journals in the interest of the rebellion teem with assaults, direct or indirect, upon the great principles of political equality on which our republican institutions are based. I shall not weary the Senate by any detailed reference to them. I will give an extract from



one as an example of many. I have taken the following extract from the Richmond Whig, of June 14, 1861. Speaking of the Southern States:

This vast region, inhabited by a people who are bred from childhood to horsemanship and the use of arms, and who know what liberty is, and love and adore it, is portioned out for subjugation by the disgusting Yankee race, who don't know how to load a gun, and look contemptible on horseback. That they may be drilled into respectable military machines by the Virginian, who commands them, is likely enough; but without disjoining the eternal fitness of things and dislocating the order of nature, that they should become capable of empire, is simply absurd. Grant that mere brute force should enable them to overrun the land like a cloud of Eastern locusts, their reign would pass with themselves. They possess not one quality that fits them for command. Since their beginning as a nation, and out of all their seething population, they have never yet produced a general or a statesman. That is an effort beyond their ability. But for organizing hotels, working machinery, and other base mechanical contrivances, they are without equals in the world. And the very law of nature which invests them with excellence in those inferior departments of humanity, condemns them to inferiority in those of a nobler and more exalted strain.

"Senator Hammond is by no means alone in his conception of the dignity of labor. There are hundreds of thousands who concur in his estimate of laboring men as the mere 'mudsills' of society, on which there should be erected an aristocracy, controlling the political power of the State.

"Do you ask me, do the masses of the people of the South understand the purpose of the advocates of this subversion of democratic government? Sir, I admit the proportion of the Southern people holding these views was, and perhaps still is, greatly in the minority. They consist mostly of slaveholders and their immediate dependants. The number of actual slaveowners in the Southern States does not, perhaps, exceed four hundred thousand, and the number of dependants and expectants in interest will not amount to above one million five hundred thousand more. But then it must be considered that these slaveholders are the principal men of wealth, education, intelligence, and social influence. Besides, sir, as I have already said, the aggressions of the few upon the rights of the many are always accomplished under false pretences. The cry of 'Southern rights,' 'Southern rights,' 'Southern rights,' has been rung in the ears of the people with such ceaseless, vehement importunity, as to create an honest impression on the public mind that grievous and outrageous wrong has been done to Southern rights already, and that still further and greater outrages are imminent. Especially has the opinion been propagated that slavery is everywhere to be abolished in defiance of constitutional guarantees, and the rights of the States are to be sacrificed to the caprices of Northern fanaticism. Thus has the 'Southern heart been fired.' Still it may be asked, how could such a meagre minority precipitate such a rebellion as now exists if the masses were not

coöperating? I ask, what had the people to do in seceding the States out of the Union, and in the organization of the Provisional Confederate Government? What had the people in my own once honored State to do in attaching Virginia to the Southern Confederacy? Nothing, sir. Nothing. They knew not when it was done. They knew not that it was in contemplation till after it was done. In secret session, with doors barred against the popular ear, with hearts steeled against the expressed will of the people, the conspirators at Richmond not only withdrew my State from the Union, but transferred her arms and her finances and her liberties to the self-constituted authorities at Montgomery; and before the people knew of the dark, infernal deed, the tread of armed legions from the Gulf States was shaking the plains of Virginia, eager to transfer the horrors of war to the Potomac and Ohio—eager to involve my neighbors and friends and kinsmen in the carnage and desolation which they ought to suffer themselves."

Mr. Saulsbury, of Delaware, offered the following resolution:

*Resolved*, That the Secretary of War be directed to furnish the Senate with a copy of the proclamation of Brig. Gen. J. W. Phelps, "to the loyal citizens of the Southwest;" and also to inform the Senate whether said proclamation was made by order of the Secretary of War, or with his knowledge or consent, and by what authority said proclamation was made.

He said: "All I want is for the people of the country to know authoritatively and positively that it is not an act of the Administration; that the Administration and this Government are not prosecuting this war for such purposes as are announced in that proclamation of Brig. Gen. Phelps. I think, sir, that that is important. I think that good will result to the country, that good will result in the prosecution of this war, by the disavowal, distinct and positive, of the Administration of any knowledge, consent, or authority to that proclamation which announces principles, wild, fanatical, and unworthy of any general in the army."

Mr. Sumner, of Massachusetts, replied: "Mr. President, it seems to me the Senator from Delaware perhaps has accomplished his purpose by introducing this resolution and calling the attention of the Senate to the proclamation in question. I presume there is no person here who assents to that proclamation, and there is no person who does not regard it as an indiscretion. At the same time, I am free to say that I consider it, to a certain extent, as an offset to the proclamation of General Sherman and the military orders of General Halleck. I do not know which is the worst. One errs on the side of the Constitution and of human liberty; the other errs on the side of human slavery. That is the difference between these two classes of documents. The fact that there is that difference is an argument that Congress should undertake to settle the whole question,

so as to give unity to the military power, so that when our army march they may march with a well-decided principle in advance. If the trumpet gives an uncertain sound, who shall prepare himself for battle? But the trumpet will give an uncertain sound just so long as we have these various discordant proclamations."

The views of members respecting slavery as the cause of the war, had now become ripe, and all future legislation on the subject was aimed to discourage and suppress it.

In the House, on the 20th of December, Mr. Shanks, of Indiana, offered the following resolution, which was laid over and agreed to on a subsequent day.

*Resolved*, That the constitutional power to return fugitives slaves to their masters rests solely with the civil departments of the Government; and that the order of the Secretary of War, under date of December 6, 1861, to Gen. Wool, for the delivery of a slave to Mr. Jessup, of Maryland, as well as all other military orders for the return of slaves, are assumptions of the military power over the civil law and the rights of the slave.

Mr. Julian, of Indiana, offered the following:

*Resolved*, That the Judiciary Committee be instructed to report a bill, so amending the fugitive slave law enacted in 1850 as to forbid the recapture or return of any fugitive from labor without satisfactory proof first made that the claimant of such fugitive is loyal to the Government.

This was adopted: ayes, 78; noes, 84.

Mr. Wilson, of Iowa, offered the following:

*Resolved*, That the Committee on Military Affairs be requested to report a bill to this House for the enactment of an additional article of war, whereby all officers in the military service of the United States shall be prohibited from using any portion of the forces under their respective commands for the purpose of returning fugitives from service or labor, and provide for the punishment of such officers as may violate said article by dismissal from the service.

It was adopted on a subsequent day.

Disloyalty was a most annoying offence in the eyes of Congress, and no efforts were spared to extinguish it. Of course, no greater crime could be committed against a government struggling for its existence. But this disloyalty showed itself in perfectly loyal communities, and consisted in almost every conceivable act which could be regarded as not supporting the Administration with "all the heart and soul," &c. The views of members were as follows:

In the House, on the 30th of December, Mr. Potter, of Wisconsin, offered the following resolution, which was adopted.

*Resolved*, That the Secretary of the Treasury be, and is hereby, requested to furnish, without any unnecessary delay, to the Committee of Investigation on the disloyalty of persons in the employment of the Government, the information asked for by letter of December 3, 1861, addressed by the chairman of said committee to the Secretary of the Treasury.

Mr. Potter, in explanation, said: "I have a similar resolution, which I desire to offer, calling for information from the Secretary of the Interior. Before doing so, however, with the

consent of the House I will state that, on the 3d day of December, I was instructed by the Committee of Investigation to call upon the heads of the Executive Departments of the Government for certain information—information which it is necessary to have in the possession of the committee before they will be able to prepare their report and present it to the House. The committee received prompt replies from the heads of all the departments except the Treasury and Interior, but nothing from them; and on the 24th of December, I addressed notes to the Secretaries of the Treasury and Interior, calling attention to my letter as chairman of the committee of the 3d instant. Nothing has been heard from these departments in reply to either of the letters addressed to them by the committee, and we are compelled, therefore, to come to the House in order to obtain this information."

Mr. Wickliffe, of Kentucky, rose to make a request. He said: "I would like the honorable gentleman from Wisconsin to furnish the House with a copy of the letter which contains the facts or information which he desires to obtain, so that we may know what it is we are calling for."

Both letters mentioned by Mr. Potter were sent to the Clerk and read, as follows:

WASHINGTON CITY, December 2, 1861.

SIR: I had the honor to receive from you a communication, bearing date the 18th of July, in which you furnish the committee authorized to inquire into the loyalty of persons in office with a list of those holding positions under you. I have now to request a further statement of the removals which have been made, designating the individuals, since your communication of the above date.

I have the honor to be, very respectfully,  
JOHN F. POTTER,  
Chairman of Committee.

THE HON. SECRETARY OF THE —.

WASHINGTON CITY, December 24, 1861.

SIR: On the 3d day of the present month, I had the honor to address you a communication on behalf of the Committee of Investigation of the House of Representatives, asking for certain information in relation to the removal of clerks in your department.

I have received no reply to that communication. As it is important that the information asked for should be imparted to the committee before their report is made to the House, I will thank you to furnish it with as little delay as possible.

Respectfully,  
JOHN F. POTTER,  
Chairman of Committee.

HON. SECRETARY OF —.

Mr. Olin, of New York, said: "I wish to propound this interrogatory. Perhaps it is improper to inquire into the proceedings of this committee; but, if proper, I wish to learn from the gentleman from Wisconsin whether, in these cases where testimony has been taken before his committee implicating any one in the employment of any of the various departments of the Government, the gentlemen thus apparently implicated have been notified of the charges or representations or insinuations made in reference to them, and have had an opportunity to adduce such testimony as they saw fit in answer to or in explanation of the

charge? I have learned incidentally that such is not the fact."

Mr. Wickcliffe, of Kentucky, opposed the resolution, saying: "Sir, I do not approve of this exercise of power which does not legitimately reside in this House. The Secretary of the Treasury has the power of appointing clerks, and the power of removal, and if he has not got sense enough to exercise that power with discretion, I say let him be removed and somebody appointed who has. Let us not divert the great and legitimate powers of this House into an inquisition to find out something against the character of these poor dependent clerks."

Mr. Potter, in reply, stated as follows: "The committee was appointed at the July session of Congress. It has been at work during the period which has intervened; and in reply to the inquiry of the gentleman from New York as to whether we have permitted to come or have called before us clerks charged with being disloyal, I frankly say to him that we have not. The reason why the committee adopted the resolution to send the charges which had been made before them, with the evidence, as to the disloyalty of certain clerks to the heads of departments, was for the purpose of enabling the clerks so charged to have the opportunity of going before their respective heads of departments, who have the whole control of the matter, and vindicate themselves against the charges, if it was in their power to do so. The committee has no power and has claimed the exercise of no power of dismissal. They have merely sent the evidence taken by them to the departments, where the character of the clerks could be properly further investigated, and where the clerks could be heard in their own defence.

"The gentleman from New York asks why these poor, persecuted men were not permitted to appear before us in their own defence. Because such men who are properly charged with disloyalty have no right to ask to come before the committee; they have no right to ask to be retained in any position under this Government. I say that in these times no man should be retained in the employ of the Government against whom there is a reasonable suspicion as to his loyalty. I say that in times like these no head of department has the right to require from a committee of investigation, or from any other source, evidence against an employé under him strong enough to hang him for treason before he will dismiss him. Yet that seems to be the position taken by the heads of some of the departments."

In the Senate, on the 6th of January, the credentials of Benjamin Stark, a Senator from Oregon, appointed by the Governor to fill the vacancy occasioned by the death of Edward D. Baker, were presented and read, and it was asked that the oath of office be administered to him.

Mr. Fessenden, of Maine, moved that the

oath of office be not administered, but that the credentials with certain papers be referred to the Committee on the Judiciary. He said: "The papers which I have in my hand are well attested—as well as they can be. They are in the shape of affidavits and written representations, most of them sworn to, and certified beyond all question to be from a large number of the most respectable inhabitants of the city of Portland, where Mr. Stark resides. They state in the most unqualified terms facts which, if true, in my judgment, go to show that Mr. Stark should not be admitted to a seat in this chamber. They state that Mr. Stark is understood by everybody in his vicinity to be an open and avowed supporter of secession; that he has openly defended the course of the South in seceding, and has given utterance to sentiments totally at war with the institutions and preservation of our country, such as approving the attack on Fort Sumter; making declarations to the effect that in the event of a civil war, which, in fact, had then already commenced, he would sell his property in Oregon and go South and join the rebels; that they were right; that Mr. Davis's government was the only government left; that there was, in fact, no government of the Union at all. Numerous declarations of that kind are sworn to by persons who are certified and proved to my satisfaction to be persons perfectly reliable. Under these circumstances, as they have been made known to the Senate in such an authentic form as they are, I think it grossly improper that the oath of office should be administered to Mr. Stark, and he be permitted to take a seat on this floor before an investigation has been had."

Mr. Bright, of Indiana, opposed the motion, saying: "I think, sir, there is no precedent for a motion of that kind. I have never known a case where the Senate refused to allow a Senator to take his seat when his credentials were properly authenticated, and he applied for admission upon this floor. I have a very accurate recollection of what took place in my own case, and in the case of my colleague, Dr. Fitch, when our right to seats on this floor was denied. I think there was a general admission on both sides of the chamber that a Senator presenting a *prima facie* case had a right to be sworn in, and that the Senate would, after the administration of the oath, take cognizance of any papers that might be presented questioning his right to a seat. I think there would be great propriety in allowing the Senator to be sworn, that he may be heard in his own defence. The fact that these papers are certified, and the fact that statements are made derogatory to the loyalty of the Senator who claims his seat, furnish no evidence to my mind of their truth. Never have baser falsehoods been put on record against any man than have been sent to the Senate against me since I took my seat at this session."

Mr. Fessenden replied by avowing his disin-

terestedness and his sense of duty, and said: "The question raised here is all about the precedents. As I said before, the times are those when we are compelled to make precedents—not to be bound by mere forms of proceeding, precedents in the body which go only to ordinary transactions, but, if necessary, to make them."

Mr. Bayard, of Delaware, followed and expressed a desire that the matter might be postponed for a day, until he could look over the papers. Alluding to the point of precedents, he said: "I differ greatly from the honorable Senator from Maine in his general principle. If there is any period of time in which there is a necessity of adhering to forms it is in times of high excitement. The mind is apt to become biased and prejudiced, and there can be no protection unless you adhere to forms under such circumstances. *Apices juris sunt jura* is a principle which the honorable Senator must know well must often be applied; that which may seem but form is really the protection of the rights of the party."

• Mr. Trumbull, of Illinois, denied that credentials had not been referred before parties had been sworn in, in the Senate. Usually, where the credentials were fair upon their face, the person claiming a seat had been sworn in as a member; but the practice had not been uniform. He stated the cases of James Lanman, of Connecticut, in 1825, and Stanley Griswold, of Ohio, in 1809.

Mr. Sumner, of Massachusetts, said: "I desire, Mr. President, to make one single remark. It is said that the proposition now before the Senate is without a precedent. New occasions teach new duties; new precedents are to be made when the occasion requires. Never before in the history of our Government has any person appeared to take a seat in this body whose previous conduct and declarations, as presented to the attention of the Senate, gave reasonable ground to distrust his loyalty. That case, sir, is without a precedent. It belongs, therefore, to the Senate to make a precedent, in order to deal with an unprecedented case. The Senate is at this moment engaged in considering the loyalty of certain members of this body, and it seems to me it would poorly do its duty if it admitted among its members one with regard to whom, as he came forward to take the oath, there was a reasonable suspicion."

Mr. Bayard, of Delaware, responded: "This is not a new state of things as regards the question of precedent, founded on mere matter of opinion. Sir, in the war of 1812 there were men sitting in the Senate of the United States, and men admitted into the Senate of the United States, that were opposed to the war and opposed to the whole action of the Government. That was a war with a foreign enemy; a war with a domestic enemy is no worse. During the conspiracy of Burr there were men in the Senate of the United States that were believed to sympathize with it, as this gentleman is be-

lieved to sympathize with those opposed to our Government. I do not know him; to me he is a stranger. I neither know his opinions nor the evidence in relation to them; but I say there were gentlemen who were generally reputed to have sanctioned Burr's conspiracy who were Senators of the United States. The cases may not be exactly parallel to any existing at present; but condemnation for mere opinion, apart from acts, never can be justice under any circumstances."

Mr. Lane, of Indiana, urged the right and the duty of the Senate to make an investigation of the matter. In reference to precedents, he said: "A word in regard to the allegation of the want of a precedent in a case like this. I suppose there is no precedent, and I trust in God there may be no occasion hereafter for any similar precedent. There is no precedent for much of our action in reference to this rebellion; there is no warrant in the Constitution for much of it, and why? Simply because no Government provides for its own dissolution; hence no precedents will reach this case."

The subject was then laid over until the 10th of January, when it was again taken up on the question of reference.

Mr. Bayard, of Delaware, said: "Now, sir, what is the state of facts? The gentleman's credentials are presented here by a Senator of the United States. According to the Constitution, each State—it is the right of the State—is entitled to two Senators; and if it happens that at any time a seat becomes vacant, and a term is broken by the death or resignation of a member of the body, the Executive of the State, in the recess of the Legislature, has the right of appointment vested in him. In this case, the credentials are presented, showing an authority, under the great seal of the State, appointing Mr. Stark a Senator of the United States until the next meeting of the Legislature of Oregon. The authority is unquestioned; no one has objected to it. Next comes the clause of the Constitution which prescribes the qualification of a Senator, and under that clause no one doubts that authority is given to a majority of this body to decide upon those qualifications. No one doubts that a majority decides on 'the returns,'—meaning the credentials—and 'the qualifications' of the member. That authority is vested by the Constitution in a majority of either House; and, therefore, when an individual applies to be sworn in as a Senator, if objection is made either to the authority to appoint him, or to the mode of appointment, or to his qualifications, beyond all question it is competent for the Senate, by a majority, judicially to decide that question, and that is what they always do. There may have been erroneous decisions made; but the presumption is, that every Senator feels that he is acting judicially in deciding, under the Constitution and on the credentials, whether the party is entitled to a seat.

"Among the qualifications prescribed by the Constitution you can find no ground for interposing an objection to a party being sworn in who is properly appointed, no matter how debased his moral character may be, no matter though he lie under the stigma of an indictment and conviction for crime. Your remedy is not by rejecting him, if the proper authority of his State chooses to appoint him, because that power is not vested in the majority of this body; but you are protected, as I will show you, by a subsequent clause, from anything of that kind. The question is left to the appointing power in the State as regards a Senator or Representative, the people or the people's agents in the State, to determine whether or not the individual is fit morally to represent them; and I suppose loyalty comes under the designation of moral character as well as under anything else. Even if there were a conviction for crime, forgery if you please, it would afford no ground, it would give no warrant to the Senate of the United States in rejecting by a majority a person who presented himself as a Senator, legally appointed by the proper authority in his own State. The Constitution prescribes the qualifications, and it has not touched any question of that kind relating to the capacity or the morality of the party. If he was an idiot you could not reject him. If he was a man destitute of all moral character, such that you would feel disgraced by associating with him, you could not by a majority of this body reject him when his State chose to send him here by the properly constituted authority. You have some authority over the subject, to be sure, as I admit; but you are violating the Constitution if, under the power which is given to you to decide by a majority on the returns and qualifications of a member, you undertake to usurp the power of adding qualifications which the Constitution has not prescribed.

"I submit, therefore, that Mr. Stark has a right to be sworn in. I speak now utterly irrespective of any opinion of what these papers may *prima facie* establish, or what would be the result of an investigation, or whether the facts stated (for they are mere declarations, not acts) would be sufficient for action in another form or not. All that is beside the question. There is no prescription by which you can make so indefinite a term as loyalty a qualification under the Constitution, which you have a right by a majority to decide is a qualification for a member."

Mr. Sumner, of Massachusetts, rose in opposition. He said: "If I understood the argument of the Senator, it was that the question of loyalty did not enter, under the Constitution of the United States, into the qualifications of a Senator, and that therefore at this moment on this threshold of the discussion the Senate was not in condition to entertain the question of loyalty raised with reference to the present applicant for a seat in this body. To that I have two precise answers: one of reason, and

one of precedent. The first answer that I submit to the candor of the honorable Senator is one of reason.

"The Senator says the Senate should not at this time consider the loyalty of an applicant for an office here, for the reason that under the Constitution loyalty is not a qualification. Sir, why is an applicant that comes to this body to take a seat to go to your chair and take an oath to support the Constitution of the United States, if it is not to give the most open testimony before the country, and before God, of his loyalty to the Union and to the Constitution? And yet, sir, the Senator tells us, in the face of evidence now lying on that table, leading us to doubt the loyalty of the applicant, leading us to doubt the very oath which he is to take, we cannot go into every consideration of the question of loyalty; that in short, the loyalty of a Senator under the Constitution of the United States is no part of his qualifications. I believe I do not do injustice to the argument of the Senator, and I believe I answer it on grounds of reason completely.

"And now, sir, I answer in the second place on grounds of precedent." The precedent urged by Mr. Sumner was that of Philip Barton Key in 1808, in the House of Representatives. He was charged with being a pensioner of the British Government.

Mr. Bayard, of Delaware, in reply, set aside the force of the precedent by saying: "The House made no decision that the ground of loyalty was necessary to the qualification of the party." He thus replied to the question of loyalty: "The question of loyalty is too indeterminate in itself. It rests in opinion. What one man may say is disloyal, another may not think disloyal. It may be that many members of the Senate now may think it would be disloyal to believe that it would be wiser and better for this country, if they could, to adjust amicably by national convention, or in any other mode, the existing differences, than to carry on the war. Is that disloyalty? Is a man disloyal because he entertains the opinion that the interests of his whole country, North and South, would be benefited by one course of things? Again, there are others who think, because the Administration is in power during war, that any opposition to the course and policy of that Administration would be disloyal. Many men would think so honestly. Others would say, no; it is no evidence of disloyalty at all. What definition, then, can there be put to the term to make it a qualification of a party for a seat in the Senate of the United States in the face of the Constitution of the United States? There is no certainty about it. It depends and rests upon opinion altogether; and that opinion may be as variable as it can be. Nay, sir, there is, as we all know, a difference in this body, as well as in the other House, as to the mode and policy on which this war should be carried on. Some tell us it ought to be carried on for the purpose of ex-

tinguishing slavery altogether, and entire emancipation. Others tell us, no; that would be the destruction of the Union if you attempt to do it. Which is loyal? Which is disloyal? It depends upon opinion. Each may be equally conscientious; and it follows not that either one or the other is disloyal to the Government because he may differ as to the means or the propriety of the mode in which this war ought to be carried on.

"I mention these facts to show how dangerous it would be to introduce, as a qualification not prescribed by the Constitution, the question of loyalty."

Mr. Trumbull, of Illinois, followed in reply, saying: "The Senator from Delaware takes the broad ground that in no case where a person presents himself here with credentials regular upon their face, can the Senate refuse to admit him to be sworn as a member of the body; and he goes so far as to say that if he were a convicted felon, still he must be sworn in as a member of the body. If then in any conceivable case it were possible that a man could be so degraded or so disloyal that he ought not to be admitted to a seat here, if he were a negro even with credentials, on the principle laid down by the Senator from Delaware, he should be sworn in as a member of this body."

Mr. Bayard: "No, sir; not on my principle. He must be a citizen of the United States to be sworn in as a member of this body."

Mr. Trumbull: "That is a matter of fact. I suppose you will inquire into that. Will you determine that by inspection?"

Mr. Bayard: "That is a matter of qualification."

Mr. Trumbull: "Ah! then you will decide, will you? You will look beyond the credentials to find out whether he is a black man. That is the very point to which I wish to bring the Senator from Delaware. Well, sir, suppose Jeff. Davis is commissioned by the Governor of Mississippi to-day as a Senator. The Senator from Delaware will swear him in as a member, and go into an investigation whether he will expel him afterward; and Beauregard and Johnson and all the confederate traitors now in arms against the Government, and ready to blow up the Capitol of the country—yes, sir, a spy sent here to blow up the building in which you sit, and you knew it, and bringing credentials from a traitor who is acting as Governor of Mississippi—is to be admitted to a seat here to set fire to the powder that is to blow up the Capitol! Such a monstrous doctrine, it seems to me, was never advocated in any deliberate body. Have we no power to protect ourselves; no power to preserve the Government? Why, sir, under this doctrine, traitor Governors may send a third of the members of this body here, and how will you expel them then?"

Mr. Bayard, in reply, said: "It is a very

easy matter to refute the argument of an opponent if you choose to misstate his position, whether it is done intentionally or unintentionally. I never pretended to say, where the credentials alone were regular, that in all cases the party was admitted. I said that, unless the objection went to the authority to appoint or the credentials, that the party was always admitted.

"Now, the honorable Senator said: Would you, if a man came here, a convicted felon, with a regular appointment by the proper authority, and with the record of conviction before you, admit him? My answer is: Yes. The Constitution of the United States, not for him, but from respect to his State and its appointing power, authorizes him to be sworn in; but the next moment that protection which the body is entitled to against infamous members, to my mind, would justify me in turning round and expelling him from a seat in the body. I would admit him because it is not left to you to decide in the first instance who shall be elected or sworn in. You have a right to supervision over your members afterward in every respect; but you must pay that much respect to the appointing power, the State which he represents, as to suppose they would not elect a disloyal, improper, or infamous man to a seat in this body. You therefore admit him, and you admit him because the majority has no right to guard against that, for the Constitution leaves it in the States."

The credentials were referred to the Committee on the Judiciary, by the following vote, and after much debate on subsequent days on a report of the committee, Mr. Stark took his seat.

YKAS.—Messrs. Anthony, Browning, Chandler, Colamer, Cowan, Davis, Dixon, Doolittle, Fessenden, Foster, Grimes, Hale, Harlan, Harris, Howe, Johnson, King, Lane of Indiana, Lane of Kansas, Morrill, Pomeroy, Sherman, Simmons, Sumner, Ten Eyck, Trumbull, Wade, Wilkinson, and Wilson—29.

NAYS.—Messrs. Bayard, Bright, Carille, Kennedy, Latham, Nesmith, Pearce, Powell, Rice, Saulsbury, and Thomson—11.

The purpose of conducting the war in such a manner as to destroy slavery, was brought out in the following debates, and was followed, at a later period of the session, by active measures for its abolition, and the emancipation of slaves.

In the House, Jan. 6, Mr. Conkling, of New York, offered the following resolution:

*Whereas*, on the second day of the session, this House adopted a resolution, of which the following is a copy:

"Resolved, That the Secretary of War be requested, if not incompatible with the public interest, to report to this House whether any, and if any what, measures have been taken to ascertain who is responsible for the disastrous movement of our troops at Ball's Bluff;"

And *whereas*, on the 16th of December, the Secretary of War returned an answer, whereof the following is a copy:

WAR DEPARTMENT, December 12, 1861.

SIR: I have the honor to acknowledge the receipt of a resolution of the House of Representatives calling for certain information with regard to the disastrous

movement of our troops at Ball's Bluff, and to transmit to you a report of the Adjutant General of the United States Army, from which you will perceive that a compliance with the resolution, at this time, would, in the opinion of the General-in-Chief, be injurious to the public service.

Very respectfully,  
SIMON CAMERON,  
Secretary of War.

HON. G. A. GROW,  
*Speaker of the House of Representatives.*

HEADQUARTERS OF THE ARMY,  
ADJUTANT GENERAL'S OFFICE,  
WASHINGTON, December 11, 1861.

SIR: In compliance with your instructions I have the honor to report, in reference to the resolution of the honorable the House of Representatives, received the 3d instant, "that the Secretary of War be requested, if not incompatible with the public interest, to report to this House whether any, and if any what, measures have been taken to ascertain who is responsible for the disastrous movement of our troops at Ball's Bluff;" that the General-in-Chief of the Army is of opinion an inquiry on the subject of the resolution would, at this time, be injurious to the public service. The resolution is herewith respectfully returned.

Respectfully submitted,  
L. THOMAS,  
Adjutant General.

HON. SECRETARY OF WAR, Washington:

Therefore,

*Resolved*, That the said answer is not responsive, nor satisfactory to the House, and that the Secretary be directed to return a further answer.

Mr. Conkling, on introducing the resolution, entered into a description of the scenes at Ball's Bluff, on the day of the battle, and a statement of his conclusions relative to that conflict, and concluded by saying, that his particular object was to learn whether the military authorities had in any manner looked into the proceedings on Oct. 21.

Mr. Richardson, of Illinois, followed, saying: "After the experiences of this House, it becomes its dignity to inquire whether we have the right and power to apply correctives to what we find wrong. On the first day of this session gentlemen, without consideration, without consultation, without the deliberation of the House, pledged themselves to do certain things in relation to the arrest of Mason and Slidell. The authorities, who in this Government had control of the matter, have not backed you up in it. What position do you occupy? Is your dignity vindicated? Have we maintained our own self-respect? If not, why? We have interfered with matters which did not belong to us, and over which we have no control.

"What does the gentleman from New York propose to do now? He proposes to investigate the disaster at Ball's Bluff. Suppose you find that somebody now living is at fault: what are you going to do next? Discuss it before a town meeting? Is that the way you conduct armies, fight battles, and carry on wars? It is unheard of in our legislation. We must trust something to the other departments of the Government.

"This House may subject the matter to an investigation of a committee; it may determine that certain persons are responsible, but the

Commanding General, the War Department, the officers to whom we must trust the management of our armies, may differ with the House of Representatives."

Mr. Crittenden, of Kentucky, opposed the resolution and said: "The general question is this: Will the House interfere in the conduct of the war and the management of the army by the investigation of transactions through its committees, which transactions are in their nature and character purely military? Have you the power to do so? Congress has power to declare war, to raise armies. What further power in the matter does the Constitution give to it? What power over the command and management of these armies has Congress? The President is the Commander-in-Chief. When you have declared war, announced its object, and raised armies, those armies pass under the command of the President of the United States, for the execution of the purpose of Congress."

Mr. Crittenden then proceeded to speak of the consequences of such interference upon the army and its officers.

Mr. Vallandigham, of Ohio, dissented from the view of the previous speaker, and said: "But I rose, sir, not merely to explain my vote, but suggest a second time, as I did the other day, that hereafter all resolutions of a similar import should be made to conform to the rule of this House, and that the responsibility which these Executive Departments owe to this House shall be rigidly enforced. Let us yield not an inch, especially at a time when executive power in its most dangerous form—the military—threatens the civil authorities with utter subordination, if not permanent overthrow. I dissent, very respectfully but totally, from the unconstitutional and dangerous doctrines of the gentleman from Kentucky; and I congratulate the country also, that gentlemen of the majority are beginning already, no matter from what motives, to fall back upon the very principles for maintaining which I have for months past been falsely and impudently denounced as an enemy to my country."

Mr. Lovejoy, of Illinois, protested also against the doctrine of the member from Kentucky, on the ground that there was a clause in the Constitution, which provided that the military should be subject to the civil authority, and then proceeded to remark upon the conduct of the war. He said: "I do not think that the want of success in our military operations is owing so much to this general or that general, to the want of military skill in this officer or that officer, as to other causes. Although, by the way, the gentleman deprecates transforming civilians into military men, and military men into civilians, I will say that we have been familiar with such transformations ever since we have been a nation. The two leading generals in our army were civilians when this war broke out—one in California, and one in Illinois; and a large proportion of the officers of the

army now were civilians when the war commenced. This must, of necessity, be so; and I believe, on the whole, that the civilians are the best officers, and will prove to be the best officers; and that the men who have received a military education are more in the way of the success of our arms than anything else. That is my conviction, though I do not wish to blame any one, or to discuss personal merits or demerits. The truth is, if I understand it, our want of success in this war is owing to the theory adopted by this Government in regard to its prosecution. The Government is holding the army in a state of inactivity—for what reason? Not because the officers are not skilful and brave; not because the soldiers are not brave and efficient; but they are holding this whole army in this stand-still position, and literally making it a *standing* army, upon the same principle that a simpleton mentioned, I think, in Grecian fable, stood upon the banks of a stream waiting for it to flow by, that he might pass over dryshod. We are waiting in the hope—in my opinion, a vain and fruitless hope—that this rebellion will put itself down; that if we do not hurt them, these rebels will return to their allegiance, and that, too, before a great while.

"But, Mr. Speaker, to return to that which I wanted chiefly to say, and that is this: I care very little about investigating these incidental facts. The great trouble is that this nation has failed, and is yet failing, rightly to interpret the providences of God. Although a reference to any higher law or providence may be received here with a smile and a jeer, yet the truth is that God is holding this nation, and refusing to allow us to achieve any victories because we are not just; because we are not true to the principles of justice, and truth, and human equality which we proclaimed in the original structure of our Government. We are failing to proclaim liberty throughout all the land to all the inhabitants thereof. I believe before God—and if it be fanaticism now, it will not be fanaticism when the muse of history traces the events of the day—that the reason why we have had Ball's Bluff, Bull Run, and other defeats and disasters, is that God in his providence means to arraign us before this great question of human freedom and make us to take the right position. Where are we now, sir? Just where a certain crew were, on a vessel whose history is found in the sacred writings. These ancient mariners put out from the shore and a storm overtook them, like that which came down upon the Trojans. The billows, foaming and raging, threatened the destruction of vessel and crew. Affrighted, they called upon their respective deities, inquiring what had brought upon them the divine displeasure, and found a certain refugee on board who had proved derelict to sacred obligations. They cast lots about the matter, referring it immediately to a divine solution, and the lot fell on the guilty person. What

then? Why, the culprit himself said he must be thrown overboard. The sailors, with characteristic generosity, tried to save him, but could not, and cast him forth, and so saved their vessel and the lives of those on board.

"Now, sir, when we cast this accursed slavery overboard, God will give us success, and will crown our arms with victory—for that is just, that is right. But no: this slaveholding Jonah has paid his fare, has got some sort of constitutional, guaranteed right, and prays and whips Christianity into its tortured catechumen: and we are here to-day, with this old national vessel drifting wildly amid the maddened waves, every spar bowing, every joint creaking, and every plank bending, while the angry ocean shivers its crested waves charged with divine wrath against its sides: and still men say, "For God's sake, do not touch this old slaveholding Jonah!" We must do it, sir. It must go to the depths, or we must: and when it is cast into the sea, God will save the nation. Then it will be a nation worth saving.

"Here is the trouble, sir. It is not in Stone, nor McClellan, nor in Halleck altogether. God uses these poor instruments to punish us, and when we take the right position He will bring us the right men and we shall be saved, but not otherwise. To this complexion it will come at last. It is written in the unfolding leaves of that book chained to the throne. This Jonah must go down into the depths of the ocean, to the foundation of the hills. We have refused to vote for the negro, we have refused to care for the negro, we have refused to sympathize with the negro, and now God has set us to fighting about the negro; and the man is blind or an atheist who does not see the hand of God in it all. History will tell you that.

"Now, Mr. Speaker, the people are determined to put down this rebellion, and I tell the Government, without the least ripple or shadow of unkindly feeling toward a single gentleman—for if I had, it would be groundless and ungrateful—intrusted with the administration of affairs, and without believing for a moment that they are not true and loyal and earnest, although, as I think, acting on mistaken theories; I tell them that the people mean to put down this rebellion, and do not mean to stand with the rope round their necks always. This rebellion must be put down by the Government or without it. I know how the people feel, and I know that the slaveholding interest of one or two border slave States will not be allowed to control the destinies of this Republic."

Mr. Wickliffe. "Will the gentleman from Illinois allow me to ask him a question?"

Mr. Lovejoy. "Yes, sir."

Mr. Wickliffe. "I see, sir, that this House passed at a former session the following resolutions:

*Resolved*, That neither the Federal Government nor the people or governments of the non-slaveholding



States have a purpose or a constitutional right to legislate upon or interfere with slavery in any of the States of the Union.

*Resolved*, That those persons in the North, who do not subscribe to the foregoing proposition, are too insignificant in numbers and influence to excite the serious attention or alarm of any portion of the people of the Republic, and that the increase of their numbers and influence does not keep pace with the increase of the aggregate population of the Union.

"In favor of the passage of the resolutions I see a gentleman's name, 'OWEN LOVEJOY.' Are you the man?"

Mr. Lovejoy. "I am that man. I thank the gentleman for that word. Before replying to it, however, I want to say, in pursuance of the line of thought which I was upon, that the people have determined, as I believe, to carry on this war so as to put down the rebellion in the speediest and most effectual way, and I have no doubt that the Government will gracefully yield to the popular sentiment.

"Now, if I understand the resolution read by the gentleman from Kentucky—and my attention was diverted from the reading of it for the moment—it asserted that we had no right to interfere with slavery in the States.

"Yes, sir; you will always find my vote in the affirmative upon any such resolution as that. But that was when these States were all loyal to the Federal Government; that was before slavery had broken out into rebellion; that was before these States had seceded, and cast off their allegiance to the Government, to all its claims, and all its obligations, and of course to all right to protection and immunity.

"Now, Mr. Speaker, it is one thing, as I understand it, for two combatants to get together in a duel, for instance, in the ancient sword practice, and contend according to rule, according to the code. If they get together even as prize-fighters, they have requirements that will not allow the combatants to strike certain parts of the body; but here is a man who is playing foul, and who is striving to take your life by any and all means: are you bound by the rules, then? Has not the Constitution the right of self-preservation?"

Mr. Richardson. "I desire to ask my colleague what was the condition of South Carolina at the time when he voted for that resolution?"

Mr. Lovejoy. "I do not remember the date of it."

Mr. Richardson. "It was in February last."

Mr. Lovejoy. "It is well understood that when this resolution passed no state of war existed, no rebellion had broken out in arms."

Mr. Richardson. "I ask my colleague whether the Star of the West had not been fired into."

Mr. Lovejoy. "I think it was subsequent to that, but no matter as to particular dates; I am talking about a state of war and rebellion as contrasted with a state of peace. Now, I suppose the gentleman from Kentucky, as well as others, will admit that the Constitution and laws require us to do a thousand things in the

present state of the country that they would not allow us to do in an ordinary condition of peace. There is no question about that. My simple point is this: I have said it once before, but as the charge is persistently made upon me, and upon those who advocate the policy which I advocate, that we are for making this an abolition war, an anti-slavery war, I again take occasion to say that that is not our purpose as an original, ultimate purpose, but only as a necessary incidental measure in the suppression of the rebellion.

"Now, I want to ask the gentleman from Kentucky a question. Does the gentleman prefer that slavery should be preserved and perpetuated rather than that the Union should be preserved and maintained?"

Mr. Wickliffe. "I will answer the question. I am for preserving this Union under the Constitution, regarding its obligations imposed upon every citizen, every section, and every State of this Union. I am not for violating the Constitution when it is not essential for the safety of the Union. The gentleman asks whether I am for preserving this Union in preference to preserving slavery. If that issue is to be raised, when it is presented I shall be ready to meet it. I believe we shall preserve the Union and slavery under it. I am for the principles as declared by the gentleman himself in voting for the resolution I have read, as declared by the President in his inaugural address and in his two Messages to this House. If these principles are observed, I have no fear that the Union and the Constitution will not be preserved."

Mr. Lovejoy. "Now the question I presented to the gentleman respectfully was, supposing it is impossible to preserve them both, suppose it becomes as apparent to all as it is apparent to some of us, as we think, that one or the other must go into the ocean—the vessel or Jonah—which shall go overboard? That is the question I propounded."

Mr. Wickliffe. "I would prefer throwing the abolitionists overboard."

Mr. Lovejoy: "I do not doubt it, and that is tantamount to saying that the gentleman prefers seeing the Union go by the board rather than slavery; for in the sense in which he uses the term he makes them identical. Those gentlemen who advocate this policy which seems now to control the army, and apparently the Administration, prefer the preservation of slavery to the preservation of the Union, provided both cannot be preserved."

Mr. Mallory, of Kentucky, said: "I will say in response to the question propounded to my colleague (Mr. Wickliffe), that so far as I understand the feelings of the people of that State—that if they ever come to regard the institution of slavery as standing in the way of this Union, or of constitutional liberty, they will not hesitate to wipe out that institution."

Mr. Stevens, of Pennsylvania, obtained the floor for the purpose, as he stated, "of trying

to put a stop to the debate." He said: "I agree with the gentleman from New York, that the reply sent to us is not an answer to the resolution of the House. I do not believe there was any intention to evade an answer, but I believe the reply was made through inadvertence; and I believe further, that the House owes it to itself to get a direct answer, and that is all the resolution proposes. I do not see upon what ground any man can vote against that. The resolution asks nothing that is improper.

"But suppose the purpose of the resolution was to get at facts for the purpose of investigation, are we to believe in the horrible and abominable doctrine of the gentleman from Kentucky (Mr. Crittenden), which was nothing else than that this House dare not inquire into the manner in which this war is conducted, and dare not inquire whether our officers are doing their duty or are traitors? Has it come to that, that this body is a mere automaton to register the decrees of another power, and that we have nothing to do but to find men and money?

"I solemnly protest against that doctrine as having no shadow of foundation in the genius of our institutions or in the Constitution itself. These arguments will be profitable. Much eloquence has been displayed here. Some things have been said which strike sadness to my heart. I have seen what I have sometimes suspected, that at last many distinguished men of the border States would rather see the Constitution and the Union go down than to see slavery abolished, if it came to that alternative. Sir, we have just given twenty thousand men to defend Kentucky, and to support slavery, I suppose, in preference to the Union, if that alternative is presented. I do not wonder that gentlemen hold that doctrine. They have a perfect right to hold that doctrine. It is my right, however, to repudiate it."

Mr. Mallory, of Kentucky, demanded: "What gentleman from Kentucky has avowed the doctrine the gentleman speaks of?"

Mr. Stevens: "I could put no other construction upon the reply of the gentleman from Kentucky over the way (Mr. Wickliffe), to the question of the gentleman from Illinois. I do not wonder that those inhabiting the border States hold such a doctrine with their attachment to slavery; I do not wonder that gentlemen across the lines in the Free States hold very much the same doctrine."

Mr. Dunn, of Indiana, immediately rose and asked: "Does the gentleman impute to me any such doctrine?"

Mr. Stevens said: "I thought from what the gentleman said he had a tenderness for the negro."

Mr. Dunn replied: "The gentleman from Pennsylvania imputes certain sentiments to one of the Representatives on this floor, from the State of Kentucky (Mr. Wickliffe), saying, as I understand him, that that gentleman preferred

the preservation of slavery to the preservation of the Constitution and the Union. He then intimates that I, living also on the border, sympathize with the gentleman from Kentucky in that feeling. I am glad of the opportunity of saying to that gentleman that I do not exalt slavery above our Constitution; that I would make no sacrifice of our Constitution to preserve slavery, and that I regard the preservation of the Union and the perpetuation of our present form of Government as far more important to me, to the people of my day, and to the generations yet to come, than the preservation of slavery. But I do not believe this Government is to be perpetuated, or that these institutions can be handed down to posterity, if, instead of adhering to that policy which we proclaimed to the world at the commencement of this controversy, we now cut loose from our moorings, and, instead of struggling for the preservation of the Government, make this a war upon slavery. I tell you that if the general emancipation of slaves is to be our policy, our Union is forever gone, and there is no redemption for it."

The vote was then taken on the resolution, and it was adopted: ayes, 79; noes, 54.

The reply of the Secretary of War to the resolution, was as follows:

WAR DEPARTMENT, *January 9, 1863.*

SIR: I have the honor to acknowledge the receipt of the resolution adopted by the House of Representatives, on the 6th instant, to the effect that the answer of this Department to the resolution adopted by the House on the second day of the session "is not responsive nor satisfactory to the House, and that the Secretary be directed to return a further answer."

In reply, I have respectfully to state that "measures have been taken to ascertain who is responsible for the disastrous movement of our troops at Ball's Bluff;" but that it is not deemed compatible with the public interest to make known those measures at the present time.

Very respectfully, your obedient servant,  
SIMON CAMERON, *Secretary of War.*

HON. GALUSHA A. GROW,  
*Speaker House of Representatives.*

The state of the Union was a subject which presented a broad field for the discussion of the measures which should be adopted to put an end to the institution of slavery, and save the life of the nation. It became a subject of discussion incidentally, and as a part of various questions which came before the House at this time.

On the 15th of January Mr. Corning, from the Committee of Ways and Means, reported the following joint resolution:

*Resolved, &c.,* That in order to pay the ordinary expenses of the Government, the interest on the national loans, and have an ample sinking fund for the ultimate liquidation of the public debt, a tax shall be imposed which shall, with the tariff on imports, secure an annual revenue of not less than \$150,000,000.

Mr. Vallandigham, of Ohio, urging the importance of preparing immediately a proper financial system for the Government, said: "The war must come to an end sooner or later; and in one way or another our foreign compli-

cations will be adjusted, with or without a war, which could not last long; but the errors or crimes of financial contrivances and embarrassments of to-day, and their results, will endure to the third and fourth generation of those who shall come after us.

"While, then, we ought to begin this work at once, let us not hurry over it. For twenty-six years the pestilent and execrable question of slavery, in every form, has been debated in this House for months in succession. Abolition petitions, the Wilmot proviso, the compromise of 1850, the Kansas-Nebraska bill, the Kansas troubles, and the Lecompton Constitution, each in turn consumed the time of the House for weeks together. And even now, with a public debt already of some seven hundred millions of dollars, increasing, too, at the rate of \$2,000,000 a day; with every source of revenue nearly dried up, and even that last resource of the inevitable bankrupt—borrowing—cut off; with all these things staring us full in the face, nevertheless the objects of the war, the conduct of the war, emancipation, confiscation, Ball's Bluff, the Trent affair, Government contracts, the Cooly trade, the Coast Survey, the franking privilege, or whatever else may happen to be the particular 'goose question' of the hour—(I beg pardon, sir, but is not that now a classic phrase?)—all of them highly important, certainly, and worthy of due consideration—are debated for days at a time, and even the best abused man in the House finds no difficulty in obtaining an audience.

"Let us prepare then at once for the great questions of finance which are before us."

Mr. Bingham, of Ohio, followed. He took the position that the war power of the Government was under no limitation. He said: "Sir, in all that I have said, or may say, touching your unlimited power to legislate 'for the common defence,' I do not mean to ignore that highest law, whose voice is the harmony of the world, and whose seat is the bosom of God—the law, not of material, but of human life; that life which is more than breath, or the quick round of blood; that life which is a great spirit and a busy heart, which is thought incarnate, mind precipitated, and which we designate by the strong word man—by whom is made the great living world of human thought, and human feeling, and human action. Nor when I speak of your unlimited power to legislate for the general welfare, do I mean that you may rightfully legislate to the hurt of the general welfare, or in wanton disregard of those rights of human nature, to protect which all good government is ordained. I admit, sir, that civil government, with all its complex machinery of civil polity, is but a means for the attainment of a more important end—the protection of individual man, the development of his deathless faculties, of his generous affections, of the immortal sentiments, hopes, and aspirations of his being.

"But, sir, it is a part of the essential econ-

omy of good government, that individual interests and individual rights must observe, at whatever cost, the public good. No man lives for himself alone, but each for all. Some must die that the state may live; individuals are but for to-day; the commonwealth is for all time.

"I reaffirm my proposition that you are intrusted by the people with the unlimited sovereign power to make all laws just and needful 'for the common defence.' What limitation is there but the public necessity upon your power to lay and collect taxes in the manner prescribed, to contract debts and borrow money, to declare war, raise armies and navies, and make rules for their government. The limitations of the Constitution may be cited.

"From all this it must be apparent that while unnecessary or wanton cruelty to the public enemy is forbidden by the law of nations, as well also by the Constitution; all else essential, however destructive of their lives and property, is justifiable—a right and a duty. If these rebels in arms against the Constitution and laws were alien, not citizen enemies, the Government of the United States, by authority of Congress, could visit upon them all these dread penalties of war, the destruction of their lives, and the confiscation of their property, so far as necessary to the vindication of the nation's rights. That they are citizen enemies does not relieve them from such penalties, or in any wise mitigate their guilt. But what is forbidden by the law of nations toward alien enemies waging war against us by the authority of their sovereign, is expressly allowed by the Constitution of our country toward these rebels. Every one of them taken in the overt act of rebellion, inasmuch as he is a citizen of the United States, and owes allegiance to the Government of the United States, may be treated as a traitor, and upon trial and conviction, may justly be subjected to the punishment prescribed by the statute upon those guilty of the crime of treason, and be subjected to such other penalties for his rebellion as may be prescribed by law. No State in the Union can legalize treason, or absolve any of its citizens from his allegiance to the Federal Government.

"The Government is invested with the right of self-defence and self-preservation, and, to that end, with the power to provide by law for the maintenance of its authority by force against all conspiracies, however sanctioned by State statutes, or State constitutions, or State ordinances of secession."

Such being the rights and powers of the Government, he next proceeded to inquire respecting its duties.

"Is it not the duty of the legislative department to provide by law at once for the employment of all justifiable force against the persons and property of these rebels, to the end not merely that the avenging arm of an insulted people may fall upon them, but that the nation may live, that justice may be established, that

domestic tranquillity may be restored, that the general welfare may be promoted, that personal security and the blessings of liberty may be forever insured. For these ends the Constitution was ordained by the people; not without suffering and martyrdom and the sacrifice of blood. Let not these ends fail of realization by any act of ours. The sacred trust of providing for the common defence is in our hands; let us not fail, so far as in us lies, to execute it."

After stating the laws which had been passed by Congress to preserve the Government, he proceeded to show that the most needed of all was an act to liberate the slaves. He continued: "Pass your laws liberating the 4,000,000 slaves held by the rebels, and thereby break every unjust yoke in that rebel region; and let the oppressed go free, in obedience to that command which comes to us as a voice out of heaven, 'proclaim liberty throughout all the land, to all the inhabitants thereof.' Do you say this is fanaticism? Do you say God was a fanatic when He commanded it, and that the fathers of the Republic were fanatics when they adopted it as the sign under which they should conquer, and burned it with fire into the very bell whose iron tongue summoned them to the stern work of resistance?"

"And do you say we have not the constitutional power to enact such a law? Why not? Because, you say, the slave is the rebel's property. I cannot admit that; but, conceding it for the moment, has he not forfeited his property, as well as his life, to the Government? Have you not by your law authorized the taking of his life, both by the sword and the gallows? Is his right to his slave, which came by wrong, more sacred than his right to his life, which is the gift of God? Has the rebel special rights and immunities of property in his slave which you do not accord to the loyal citizen? Are you not about to assert your power to take the property of the true and loyal citizen by taxation, to the extent needed for the public defence? Do you stop with a law demanding the property of the loyal citizen? Do you not demand his life as well, and the life of the first-born of his house? Why, sir, the loyal citizen has no right or immunity which must not yield to the paramount claims and wants of an imperilled country. Even his house and home, the most sacred possession of man on this side of the grave, must, by the very terms of your Constitution, be yielded up for the common defence:

No soldier shall in time of peace be quartered in any house without the consent of its owner; nor in time of war, but in a manner to be prescribed by law.—3, *Amendments to the Constitution.*

"You may thus in war exercise a power which in time of peace, even under the constitution of monarchy, is denied to the sceptre and the throne. The words of the great commoner of England will live forever:

The poorest man may in his cottage bid defiance to all the powers of the Crown. It may be frail, its roof

may shake, the wind may blow through it, the storm may enter, the rain may enter, but the king dare not enter—all his forces dare not cross the threshold of the ruined tenement.

"By your law this inviolable sanctity of the hearthstone, whence comes the nation's strength, may be swept away, and yet you cannot confiscate the property or liberate the slaves of rebels in arms. Believe it not, sir, though one rose from the dead to proclaim it."

The previous question was then called for, and the resolution passed: ayes, 184; noes, 5.

Subsequently, on the same day, the House went into Committee of the Whole upon the appropriation for certain fortifications. Mr. Wadsworth, of Kentucky, improved the opportunity to reply to Mr. Bingham, as follows: "A resolution, the most important, I undertake to say, yet introduced into this House, was brought in here, and a speech in interpretation of the purposes for which it was introduced, and as a commentary upon its text, from the distinguished gentleman from Ohio (Mr. Bingham), is delivered, and then the previous question is sprung and sustained by the majority, and gentlemen are asked to vote at once under that commentary and under that previous question, and without any answer to the most remarkable speech, considering the source from which it came, that was ever heard upon this floor. I am never startled when the gentleman from Illinois (Mr. Lovejoy), who sits yonder, rises, upon that subject so near his heart, to teach us his construction of the Constitution, the will of the Lord, and the duty of the nation in this rebellion. Nor am I astonished when the distinguished gentleman from Pennsylvania (Mr. Stevens), and who gives me the honor of his attention, rises and unfolds his views upon this question.

"But I was astonished in more respects than one when my neighbor from the State of Ohio delivered his views of the policy of the Government, and laid down the boundaries—the no boundaries, rather—of the power of Congress to provide for the common defence and the public welfare—astonished in more than one respect. A gentleman for whom I had the highest esteem, and whose course, as I had observed it here, gave me the impression of a patriotic man and a learned lawyer, rises here and tells the Representatives of the people that there are no boundaries to that power, and that Congress is omnipotent to provide for the common defence, and that, under that general phrase of the Constitution, all other limitations of the Constitution are swept away as chaff, and that we may do anything in the world not forbidden by 'natural right.' Sir, is not the limitation itself absurd?"

"The argumentation by which so startling a proposition as that was supported was equally surprising. It was asserted that trial by jury, indictment, presentment, all the guards thrown around the rights of the citizens of this country, were swept away, because alien enemies had no

such rights. It was argued that the power to take life without due process of law, and without trial by jury, was implied because we could take life by court-martial—bring a man to the drum-head, condemn him to death, and execute him. It was argued that the power 'to make rules concerning captures on land and water' implies the power to take the property of citizens without making compensation therefor, and without due process of law. With fervid declamation and with an utterance thickened by intense feeling, the gentleman rushed into these extremes, and pointed out what he would do under these supposed powers to my constituents as well as the constituents of other gentlemen upon this floor. Now, sir, I do not give in to any such interpretation of the Constitution as that. Not one dollar will I vote, not one man will I grant for any such purpose, or to sustain any such interpretation. Nay, more, sir, I will give all that my people have, their cattle on a thousand hills, their slaves, their lands and tenements, their lives, even to the last one of them, to resist any attempt to enforce such a construction of the Constitution as that to the ruin of the people of this country.

"And, sir, I am not one of those who prefer slavery to the integrity and glory and perpetuity of my country. I prefer its renown and its integrity above all property and to my own poor life, and have proven it. All that my people have they are willing to give for the defence of the Constitution and the Union. The glory and renown and preservation of their country is higher than any other earthly consideration. Kentucky has gone into this war to extinguish rebellion by the sword, and she never will lay down that sword while the war is waged in the spirit of the Constitution till that great purpose has been accomplished, and the audacious men who have precipitated this ruin upon the country—the leaders and controllers in the council and in the field—have been brought to the halter.

"Is it necessary that I should attempt to answer a constitutional argument, such as that to which I have referred—that Congress has power for the common defence to do anything that can be done that is not forbidden by natural rights? No, sir. I maintain that the Federal Government is not sovereign. I declare that sovereignty does not reside in the States, and that there is no such thing as sovereignty in this country except the sovereignty of the mass. The Federal Government itself is not sovereign, but limited in many and important particulars. The State Governments are not sovereign. The Federal Government can do nothing that is not permitted to it in that instrument which brought it into being, and upon the preservation of which its existence depends. Yet it is argued that all which is not forbidden by natural right may be done for the common defence. That to preserve the nation we may break open the temple of the

Constitution, and steal thence 'the life o' the building.' Sir, it is not contrary to natural right to establish a monarchy in this country; it is not contrary to natural right to pass *ex post facto* laws; it is not contrary to natural right to unite Church and State; it is not contrary to natural right to found orders of nobility; and yet can all these monstrous things be done to provide for the general welfare and the common defence, whether you base the argument upon the preamble of the Constitution or upon the eighth section of article one—to which, I suppose, the gentleman refers—which declares that 'the Congress shall have the power to lay and collect taxes, duties, imposts, and excises, to pay the debts, and provide for the common defence and general welfare of the United States?' Can it be contended for a moment that such vast and illimitable powers belong to Congress? No, sir; Congress can provide for the common defence only in the manner that the Constitution points out, and by the exercise of the powers granted by that instrument. Congress can exercise all those great powers which are conferred upon it by this Constitution for the common defence; it cannot exercise one solitary power not granted by this instrument, or necessarily inferable from its language. It overthrows our whole theory of government to say that Congress can exercise any power not expressly granted by the Constitution or necessarily implied from the language of that instrument; all other powers are unnecessary, so determined by that great work.

"There are two dangers which threaten the Union. One is a foreign war; and the other, dissension among the friends of the Union. We might outlive the storm of foreign war.

"But, sir, dissension among the friends of the Union would have a far wider result. From the passage of an act of emancipation, the lines of the rebellion would advance; it would receive a fresh impulse; its original pretence would be justified as truth. Some of you propose to emancipate the slaves of loyal masters as well as those of rebel masters. Some of the gentlemen say the loyal man has no more right to hold slaves than the rebel; and with their view of the institution, they are right; of course, if slavery is a sin, no man has a moral right to hold slaves. A virtuous man should not commit sin. Then, I say the first attempt to emancipate slaves will necessarily result in the enlargement of the boundaries of the rebellion. Millions in the revolted States, now faithful, awaiting in silence and grief the coming of the banner of their country, with one heart would join the foe. That instant the people of Missouri, Kentucky, and Maryland would resist the execution of such an act; that instant the loyal men of these States, with many of the men from the free States in arms for the maintenance of the Union, but who have not gone into the war for the purpose of freeing slaves, or to accomplish the Africaniza-

tion of our society, will disband. Yes, sir; justice, honesty, and humanity, everythig that is honorable in the human character, would compel them that instant to throw down their arms. They would revolt at the idea of having been drawn into a war under the pretence of sustaining the Union, but in fact for the purpose of forcing emancipation upon the States of the South.

"Then how would you fight your battles, already sufficiently arduous? I see the distinguished gentleman from Pennsylvania leading the charges upon the cohorts of rebellion and storming the batteries armed by treason and theft. I think I see the meek-faced gentleman from Indiana (Mr. Julian), who read his printed composition to the committee the other day upon 'the sum of all human villainies,' I think I see him heading a charge against the regiments of rebellion. Yes, sir, the war would be brought to a speedy conclusion with men like these to fight it. They are not the fighting men; they belong to what is known as the school of humanitarians; they deprecate the shedding of blood, and do not like the smell of villainous saltpetre. Unless you bring emancipation into the war they will not vote another man, another dollar, to carry on the war. They will permit the rebellion not only to profane with storm and slaughter this capital, bearing the honored name of Washington, but they will permit it to burn Baltimore, Philadelphia, and New York, to overwhelm the nation in its progress rather than vote a man or a dollar, unless you, the representatives of the people, will give an anti-slavery turn 'and vigor' to the war. Who does not know the objects of these things? These men belong to the peace party; they and their policy aim at disgraceful peace, and a dissolution on the slave line.

"Mr. Chairman, we, who are from the States most nearly concerned, have sat here for weeks and weeks, and suffered this question to be brought forward and debated in the most intemperate and offensive manner. We have heard them talk about the slaveholder as if he were not their peer, and of the same race as themselves. Yet, for the sake of securing the great measures necessary to accomplish a successful termination of this war and the preservation of our torn country, we have sat still and endured it. No forbearance moves their 'stern, inexorable hearts.' The consideration of these topics has been forced upon us by the peace party in this House, who believe that if this question of emancipation is forced into the war there will be fifteen States in the rebellion instead of eleven; and that peace and dissolution follows.

"They may be disappointed in this. As for ourselves, we do not intend to quit this Union—we will never give up our lot and part in it. We will find ways and means and friends and safety for all our rights in the Union. We will never commit the mighty sin, the mightier

blunder, which the seceded States have committed, of going out of the Union. Every acre of all the lands from Atlantic shores to Pacific seas forms a part of our inheritance, and our country, and we will never surrender one grain of all their sands. If you commit the great blunder of making this a war for emancipation, then let me tell you that we will stand by the Constitution that your fathers and our fathers gave to us; we will seek beneath its ample shield protection from the horrors of servile insurrection, and the preservation of liberty and equality, our inalienable birthright. The cotton States cut themselves off from the sympathy of the conservative men in the halls of legislation, as well as from their support upon the field of battle. We of Kentucky will not break away from this Union and enter into the same folly of rebellion. No, sir; we have sworn by the blood that cemented it; we have sworn by the great men who founded it, and our own great departed Teacher; we have sworn by every tie of affection and honor eternal fidelity to it, and we will defend ourselves and our rights in the Union, not out of it, to the last gasp. And in that contest we expect to see worthy patriots from all the States rallying to our aid in Congress, or as we now see them, upon the tented field. We expect, too, patriot Presidents; rulers of the whole people, to interpose to shield us from oppression. The result cannot be doubted. The Union and the Constitution, the cause of right and justice, will prevail, and abolition and rebellion meet a common fate."

On the close of Mr. Wadsworth's remarks the House adjourned.

The subject was again considered on the 20th, in committee, when Mr. Fessenden, of Maine, took the floor and summarily expressed his views thus: "Mr. Chairman, possibly we may ultimately be successful in this war without taking such measures as shall result in the abolition of slavery. Possibly we may be strong enough to do this, and leave slavery in the slave States *in statu quo ante bellum*. I do not believe, however, that we are sufficiently powerful to accomplish this object, if it be our object, because I cannot disbelieve that God has good still in store for us. But possibly, I say, we may have this power, as many have the will. But in this event, we return from victory, as did the Thracian horse, still bearing a master on his back."

Mr. Steele, of New York, followed, on the other side. He said: "It is my firm belief that if abolitionism should rule the day, this war would become one of extermination and death all over the country; that 'the blackness of darkness' would overshadow the land, and the sun of liberty go down in blood, thereby extinguishing the hopes of freemen for a republican government, and obliterating all reasonable grounds for expecting the permanent sovereignty of the people."

Mr. Wright, of Pennsylvania, then com-

menced some remarks upon the objects of the war and the just and proper mode of carrying it on. He said: "What was the policy of the war? I refer you, I refer the committee to that proclamation of the President of the United States, issued on the 15th day of April last, calling out seventy-five thousand men, in response to which six hundred thousand men are to-day marshalled in the field. And I want gentlemen on the other side to bear with me while I refer to a paragraph from that proclamation, which went out from the White House on that day. I want the attention of gentlemen calling themselves Republicans upon this floor, because it was enunciated as a part of their policy, because it has been carried out by the man whom they placed in power. I want them to adhere to that policy; for it is to them I am talking to-day. I now ask the Clerk to read from that proclamation the paragraph I have indicated."

The Clerk read as follows:

Now, therefore, I, Abraham Lincoln, President of the United States, in virtue of the power in me vested by the Constitution and the laws, have thought fit to call forth, and hereby do call forth, the militia of the several States of the Union, to the aggregate number of seventy-five thousand, in order to suppress said combinations, and to cause the laws to be duly executed.

The details for this object will be immediately communicated to the State authorities through the War Department.

I appeal to all loyal citizens to favor, facilitate, and aid this effort to maintain the honor, the integrity, and the existence of our national Union, and the perpetuity of popular government, and to redress wrongs already long enough endured.

I deem it proper to say that the first service assigned to the forces hereby called forth will probably be to repossess the forts, places, and property which have been seized from the Union; and in every event the utmost care will be observed, consistently with the objects aforesaid, to avoid any devastation, any destruction of or *interference with property*, or any disturbance of peaceful citizens in any part of the country.

"There, Mr. Chairman, is the first summons that went out from the American Government in regard to the objects and design of this war when the first demand for troops was made. I wish Republican gentlemen of this House to tell me what the President means by this language:

In every event, the utmost care will be observed, consistently with the objects aforesaid, to avoid any devastation, any destruction of or *interference with property*, or any disturbance of peaceful citizens in any part of the country.

"What did the President mean by alleging, when he called a military force into the field, that there should be no interference whatever with property of any kind? Sir, if he meant anything, he meant that this question of slavery agitation should be let alone; or, in his own language, that there should be no interference with property. If you adopt the doctrines advanced by the gentleman from Ohio (Mr. Bingham), in his place a few days since, and declare that four millions of slaves shall be

manumitted and set free, you do interfere with the rights of property, and you do oppose the Executive proclamation.

"Mr. Chairman, the next thing that was done in the process of time, defining the object of the war, was the adoption of the resolutions offered in this House by the gentleman from Kentucky (Mr. Crittenden), upon the 4th of July last.

"Up that point, then, there had been no change of policy in reference to the prosecution of the war. Those resolutions embodied the principle upon which the war was inaugurated, to wit: to put down rebellion, and not to manumit slaves, and to set them loose upon the community—four millions of illiterate, and I may almost say half barbarous people, without any means of support, leaving the Government to take care of them, or the people to guard themselves against their inroads. Yes, sir, the adoption of the principle contended for by the gentleman from Ohio (Mr. Bingham) would lay waste the fair State of Kentucky. Its adoption would strike from the charter of our liberties Maryland and Western Virginia, and the State of Missouri. Why, then, will gentlemen contend for carrying out an idea which strikes at the homes and hearthstones of as loyal men as exist in the Union this very day? Let it be the policy of the Government to carry out the Crittenden resolutions, and I firmly believe, Mr. Chairman, that the Union is safe; but if you make this a war of slave emancipation, as God is my judge, I believe that the Government is irretrievably gone. This is no war for slave emancipation; it is to put down rebellion and treason; to save a great and mighty republic from overthrow and ruin."

Mr. Diven, of New York, followed, saying: "Mr. Chairman, I suppose I need not state to this House that since the assemblage of this Congress at the extra session a principle has been gathering strength that has divided the councils of this House, and that has divided the sentiments of this country. One side of the question has been strongly represented upon this floor. If the other side has remained quiet, I apprehend it has not been because they have not been as firmly rooted in their principles as the side that has been more active. If we were to judge from the debates which have occurred in this House, it might be supposed that the Executive of this country had no support from the party that elevated him to power. All the attacks which have been made upon the Administration have come from the Republican side of this House, and all the replies which have been made to those attacks have come either from the Democratic side of the House, which opposed his elevation to power, or from those who represent the border States, and who really were neither for nor against him in the election.

"There is another set of men here, among whom I rank myself, who are in favor of prosecuting this war in the spirit in which it was

commenced—for the purpose of restoring this Union to its original position, and leaving all these States in the possession of the same constitutional power that they possessed before this rebellion. That is the division that exists, and I regret that it has been made and has to be met now. It ought not to have been made now. Those men who want to prosecute this war for the paramount purpose of abolishing slavery, must know, if they know anything, that they cannot attain their end until they annihilate the rebel army that stands between them and the slaves. We, also, who want to prosecute this war for the restoration of the Union, know equally well that we never can attain our end until we annihilate that same army. Thus far we are travelling upon the same road. The same force is to be overcome for the attainment of either end. Why, then, should we not unite all our energies? Why, then, should we introduce any disturbing element to divide our councils or distract our aims? Why should we not employ those whole energies in obtaining a victory over this common foe, and when that shall have been attained, then determine what use we will make of that victory? That is the spirit in which I should have been glad that the affairs of this country should have been conducted.”

Mr. Stevens, of Pennsylvania, now took the floor to close the debate. He argued that the salvation of the country demanded the most thorough measures, and said: “The question now again recurs, how can the war be carried on so as to save the Union and constitutional liberty? Prejudice may be shocked, weak minds startled, weak nerves may tremble, but they must hear and adopt it. Those who now furnish the means of war, but who are the natural enemies of slaveholders, must be made our allies. Universal emancipation must be proclaimed to all. If the slaves no longer raised cotton and rice, tobacco and grain for the rebels, this war would cease in six months. It could not be maintained even if the liberated slaves should not lift a hand against their masters. Their fields would no longer produce the means by which they sustain the war; unconditional submission would be the immediate and necessary result. The sympathizer with treason would raise an outcry about the horrors of a servile insurrection, and would prate learnedly about the Constitution. Which is most to be abhorred, a rebellion of slaves fighting for their liberty, or a rebellion of freemen fighting to murder the nation? Which seems to you the most cruel, calling on bondsmen to quell the insurrection, or shooting down their masters to effect the same object? You send forth your sons and brothers to shoot and sabre and bayonet the insurgents; but you hesitate to break the bonds of their slaves to reach the same end. What puerile inconsistency!

“But it will be said that the Constitution does not authorize Congress to interfere with

slavery in the States. That is true so long as the Constitution and the laws are *in fact supreme*; as in times of peace, when they can be maintained by the ordinary tribunals of the country. I believe there is no one in this country who would attempt it. But when the Constitution is repudiated and set at defiance by an armed rebellion, too powerful to be quelled by peaceful means, or by any rules provided for the regulation of the land and naval forces, the Constitution itself grants to the President and Congress a supplemental power, which it was impossible to define, because it must go on increasing and varying according to the increasing and varying necessities of the nation. The Constitution makes it the duty of the President to see that all the laws be executed. If any unforeseen and uncontrollable emergency should arise endangering the existence of the Republic, and there were no legal provision or process by which the danger could be averted, the section of the Constitution which says that ‘the President shall take care that the laws shall be faithfully executed’ creates him, for the time being, as much a dictator as a decree of the Roman senate that the consul ‘should take care that the commonwealth should receive no detriment’ made him a dictator, and gave him all power necessary for the public safety, whether the means were inscribed on their tables or not. Of course such power would be limited by the necessity, and ought to exist only until Congress could be convened. The Romans, I believe, limited theirs to six months. But when Congress would assemble, they would possess the same full powers. They are authorized to raise armies and navies; to organize and call out the militia ‘to suppress insurrection and repel invasion.’ Lest these enumerated acts should prove insufficient, it wisely provides that

Congress shall have power to make all laws that shall be necessary and proper for carrying into execution the foregoing powers, and all other powers vested by this Constitution in the Government of the United States, or in any department or officer thereof.

“This Government is empowered to suppress insurrection; its Executive is enjoined ‘to see all the laws faithfully executed;’ Congress is granted power to pass all laws necessary to that end. If no other means were left to save the Republic from destruction, I believe we have power, *under the Constitution and according to its express provision*, to declare a dictator, without confining the choice to any officer of the Government. Rather than the nation should perish, I would do it; rather than see the nation dishonored by compromise, concession, and submission; rather than see the Union dismembered; nay, rather than see one star stricken from its banner, all other things failing, I would do it now.”

On a subsequent day, Mr. Riddle, of Ohio, urged the same principle, but upon different grounds. He said: “We are told on conclusive



grounds that this rebellion has opened a vast and limitless source of law, that lies sealed up during the periods of peace, but which springs forth a sceptred king at the first footfall of an armed foe. It is called the war power; and without definition or outline it comes to the aid of a beleaguered nation. It is said that this extraordinary agency can fulminate its edicts alone through the voice of a commander-in-chief at the head of his armies; and that in no form can or does it attach itself to the ordinary legislature. This I deny. We are the legislative power—the proclamation of a rule that changes existing relations is the enactment of a law, simple and pure; and the Constitution confers no semblance of legislative power elsewhere. If a new fountain of law-making power is opened up, it naturally flows to us, and we may and should embody so much of it as we deem necessary into the ordinary forms of statutes. This power—undefined, vague, and shadowy—can nowhere else be so safely exercised as by us; and rather than permit an Executive to be clothed with it, without limit or definition, and thus make him an irresponsible despot, I would deny its existence and resist its exercise. With us it is safe; even a usurpation on our part that did not impinge upon a coordinate branch of the Government may be comparatively harmless.

“I hold, then, that this war power, whatever it may be, or whence its source, is our special property; and it may be well to inquire whether we have not already permitted its exercise by the Executive to an extent trenching upon danger. On broader grounds yet may the power to deal with this matter be most securely rested. Nations, like individuals, possess inalienable rights; and for the same reasons. An individual sustains certain relations, and is under consequent obligations from which he cannot be discharged—to the God who created him, to his fellows about him, and to himself. To insure a performance of these, he possesses certain rights and privileges that cannot be taken from him, and with which he cannot part by any act of his own; and if such a pretended alienation has taken place, enforced or voluntary, he may at any moment and under all circumstances, resume them. For the same reason and to the same extent, a nation must possess these rights, which pertain to it simply because it is a nation; and without them it cannot discharge the paramount obligations of protection to its subjects, and self-defence.

“In the application of our power, however derived, to the subject under consideration, I would adopt the principles of that proclamation to the language of which the oppressed and laboring heart of the nation rose up as to the voice of God—the property of all the rebels should be confiscated, and their slaves ‘are hereby declared free.’ My convictions and judgment might carry me further, but there are checking considerations that at this time, to me, render this inexpedient. I know that our

amazing policy in this gasping, strangling contest for the breath of life is thus far the reverse of this; we even reject with scorn the aid of one entire and powerful class of our subjects; that race, too, for whose destiny and our own the war is; and yet we will perish rather than aid shall come from them. Nay, we will perish rather than seek to withdraw them from striking with our mortal foes. Was ever fatuity so sublime? What can be the solution of this prodigious folly? Is it indeed true that slavery is the one holy thing, so sacred that even in this struggle we are to remain the enemies of our own allies, and the allies of our enemies against ourselves? There never was a war conducted so lambent and so lamb-like, where the persons of your enemies are too sacred to be smitten by any save a pure white; and where you so carefully guard their feelings against the mortification of being beaten in the field by the kindred of their own bondmen. Never, until we can shuffle off these sickly and sickening sentimentalisms, and confront this great catastrophe with all the means that lie within our grasp in our hands, shall we be equal to its fearful demands. Gentlemen may turn their pallid faces loathingly away, and hold their weak stomachs, but I say to them that they and their policy must go to the rear—the front of this battle is for other hands.”

Mr. Sheffield, of Rhode Island, dissented entirely from the grounds urged by the preceding speakers on which to authorize emancipation, and said: “Now, gentlemen may ask me what I would do in Congress in reference to putting down this rebellion. I frankly tell these gentlemen what I would not do. I would not violate the Constitution I had sworn to support, and to maintain which my fellow citizens and friends were now endangering their lives upon the battle field. I would not spend the time of this House in trying to depreciate the efforts of the Administration and of the army in putting down the rebellion, or in making inflammatory appeals against the horrors of the institution of slavery, or against those men who are battling with us for the Union. Now, I will tell these gentlemen what I would do. I would direct the attention of Congress to providing the means and the men to put down the rebellion. We cannot otherwise legislate against it effectively. I would put it down in the only way in which it can be put down; I would fight it down. I would move on the army; and as the army went on, I would capture and send to the rear every disloyal person I could find. If slaves were found among those disloyal persons, I would capture them, and, by the laws of war, as I understand them as pertaining to captured property, the proprietorship of such slave would immediately vest in the United States. I would allow the slaves to remain the property of the United States, in the rear of the army, until treason had been put down, and until the rightful jurisdiction of the civil authorities was

extended over the whole Union; and then I would treat the slaves and their masters as I, in view of the light which then appeared, should deem to be just to those interested and to the country.

"Before they can be punished by any act of Congress, they must be convicted by a verdict of a jury from the State and district where the crime was committed. That, sir, is the form and mode of trial prescribed by the Constitution under which we live. How are you going to convict traitors before a jury of traitors? This is a practical difficulty which gentlemen do not seem to foresee."

In the House, on the 14th of February, the following joint resolution was considered:

*Resolved*, That the joint committee on the conduct of the present war be authorized to employ a stenographer, who shall be paid out of the contingent fund of the Senate at the same rate of compensation as that received by the reporters of the Congressional Globe.

Mr. Wickliffe, of Kentucky, said: "We have a Constitution which prescribes the duty of each department of the Government. The conduct of a war, when such exists, is specially confined to the executive department of the Government. But the Congress of the United States, not content with performing its legislative functions and furnishing the means which the requirements of the executive department demanded, has undertaken to take charge of the conduct of the war by means of a joint committee.

"I wanted to see why it was that the Congress of the United States committed this important power to a committee, which, of right, belongs to the President. I confess that when I saw what was done, I was struck very forcibly with an item of history, which I once read, connected with the French Revolution. The Chamber of Deputies was about to be overrun by the Paris mob. Minot, the commander of the army, was overpowered in that struggle. The members were alarmed, and some one suggested to call in a lieutenant—a young man called Napoleon Bonaparte—to consult him. He came, and was consulted. He was asked what was his opinion as to the cause of the defeat of Minot the day before. He answered, 'because of the interference of the Deputies.' They appealed to Napoleon to take the command. He consented to it, on condition that the Chamber of Deputies were to mind their own business, and not to interfere with the military department of the Government. They had to agree to his terms; and he saved them.

"Well, sir, let us turn back to the motives and ends which it is said this committee have in view. Of all things upon God's earth, the most hazardous to us at this time is to create in the army, in the country, in this House, a distrust of the ability or capacity of the men who have charge of the movements of this army, by your operations through the committees of this House. Men will not fight if they have not confidence in their leaders. You

have a Commander-in-Chief in whom the nation seems to have confidence, and I have seen nothing that should indicate that that confidence has been misplaced. You complain of want of action. Why, look at the condition of the country when this rebellion commenced. The former Secretary of War had gutted your arsenals and placed your arms within the reach of those who desired to destroy the Government. He had scattered your loyal army to the remotest frontiers, so that it was hardly possible to get a guard around this Capitol to maintain peace against the insurrectionary men who would, if they had the power, have prevented the inauguration of a President constitutionally elected by the people of the United States. And, sir, but for the patriotism in the States near at hand, and the promptness with which the people sprang to arms and rallied to its defence, this Capitol would last spring have ceased to have been the Capitol of this Government; it would have been in the possession of the armed forces of the South. The Government had not left in its arsenals in the loyal States, or in its forts, arms enough to have placed in the hands of twenty-five thousand men at the time this invasion was threatened. But, sir, we did get some volunteers, and some of them fought very well."

Mr. Gooch, of Massachusetts, in reply said: "Now, sir, I desire to say a few words in reference to the manner in which the committee has performed its duties. The committee entered on the performance of its duties as soon as it came into existence. I know not on what authority the gentleman from Kentucky rests the allegations which he made, and I will yield to him most cheerfully that he may state his authority to the House."

Mr. Wickliffe replied: "The statement which I made was, that the commander-in-chief had been before the committee, and was questioned as to the manner in which he carried on the war, and that he made an answer which satisfied me. The gentleman from Massachusetts knows whether that is true or not.

Mr. Gooch, of Massachusetts, in continuation said: "I am perfectly free to say, because it is known of all men, that the general commanding the Army of the United States did appear before the committee, not by summons, but by invitation; and I am free to say still further, that I think this House has too much respect for the men who constitute that committee to suppose that they asked him any questions respecting the conduct of the war which he had the least objection to answer, or that they made a single inquiry of him in reference to his plans or purposes, or that they took his testimony in any form whatever. That they did have an interview with him—agreeable to both parties, I believe—is true; but that they called him before them as a witness, is not true.

"Now, sir, there was an allegation made here the other day against the committee, that it was a secret committee. So far as that

charge goes, we plead guilty. There have been present at investigations of the committee only the persons necessary for the carrying on of its business. The committee deemed it its duty to keep secret whatever was communicated to it by witnesses. They did not suppose that they should make revelations to individuals or to newspapers, or that the members of the House should be called upon to read the proceedings of one of its committees in the newspapers, in advance of their report to the body which constituted it.

"Now, sir, there is still another allegation against the committee, and also against the Senate and the House. It is, that the committee or Congress had usurped, or intended to usurp, the prerogatives of the Executive. I know of no such intent on the part of the committee or of Congress. Every man knows that while the different branches of this Government work together energetically and harmoniously, it is the strongest, most powerful form of government on earth. But, sir, when the legislative branch does not cordially and earnestly support the Executive, or when the Executive fails faithfully to execute and enforce the enactments of the Legislature, or when the Judiciary uses its power to defeat the legitimate action of the other branches, it becomes weak and impotent. Legislature, Judiciary, and Executive are each parts of the common whole; and while each is to a certain extent independent in its action, the concurrent action of all is requisite to the exercise of the powers of the Government."

Mr. Crittenden, of Kentucky, followed, saying: "I do not rise for the purpose of entering into any debate in connection with the policy or propriety of our constituting this committee, although I am entirely opposed, not on account of any objection to the gentlemen composing it, but on account of graver and higher objections, to the organization of any such committee, constituting a little *imperium* in our own body, whose proceedings are necessarily obliged to be secret, and contrary to the spirit of our Constitution. At best, I am totally opposed to the committee, and think it ought to be abolished as soon as the House can do it, and that for the very purpose of preserving that harmony and concurrence of action which the gentleman thinks is necessary to the efficiency of the Government."

Mr. Thomas, of Massachusetts, said: "I was among the members of the House who voted against the appointment of this committee. I should so vote again to-day. I think the appointment of the committee wrong in principle. I think it is useless for any wise purpose."

Mr. R. Conkling, of New York, said: "If the gentleman will allow me, I should like to indulge in one remark. I am one of those who voted to raise this joint committee, and I cannot agree that it is useless, as was said by the gentleman from Massachusetts (Mr. Thomas). On the contrary, I believe the action of Congress, and, among other things, the creation of

this committee has been instrumental, with other kindred agencies, in bringing about valuable reforms—reforms which have inaugurated beneficial changes and a vitalizing policy, without which we might not have had even the victories which to-day millions applaud."

Mr. Crittenden, of Kentucky, observed: "I have been under a great misapprehension, as it seems, as to whom our gratitude was properly due on this occasion. I believed it was generally supposed that we owed these victories to the valor of our army and the skill of our generals."

In the House, on the 17th of June, the bill for the issue of Treasury notes was taken up.

Mr. Spaulding, of New York, the Chairman of the Finance Committee, upon introducing the resolution said: "The largest latitude is given to the President, Secretary of War, and Secretary of the Navy, in carrying on the war. They have full discretionary power to contract all the debts which they may deem necessary to amply supply the Army and Navy. All parties loyal to the Government are united in urging a vigorous prosecution of the war; all parties, therefore, ought to be willing to furnish all the means necessary for this purpose. We must, at any rate, pay all the debts contracted by the Executive in the progress of the war. If we knew how much this would amount to, we could easily figure up the amount of the bonds and notes which Congress must authorize the Secretary to issue. No man, not even the President, the Secretary of War, the Secretary of the Navy, the Secretary of the Treasury, or the chairman of the Committee of Ways and Means, or all of them together, can give even an approximate estimate as to the whole cost of this war, because they do not know the number of years it will continue, nor what will be the final solution of the grave questions involved. We are working out a great problem, the result of which no man can know. Slavery was the cause of this war; and until the solution of the slavery question is arrived at, and the cause of the rebellion removed, we have no hope of permanent peace and tranquillity. This will take a long time; but how long no man is wise enough to determine."

Mr. Wickliffe, of Kentucky, followed, saying: "I came here pledged to my people, pledged to my conscience, and determined to vote all the men, means, and money necessary to defend the Constitution and Government from the assaults of its enemies; to do all that I could to put down this rebellion; to maintain the Constitution of our fathers as it was given to us, and to leave the State governments, when you have overcome the rebellion, in the possession of all their constitutional rights and privileges, and with all their constitutional obligations resting upon them. I was told by the secession party opposed to me, that this war would be waged and turned into a war for the subjugation and destruction of the State

governments, and for the emancipation of their slaves. I met that charge as best I could. I met it by an appeal to the vote of this House, and a two-third vote, too, by which you proposed to amend the Constitution of the United States, by declaring that Congress should not, in any shape or form, interfere with slavery in the States, and that the Constitution itself should not be changed so as to authorize Congress to interfere with the slave property of the South: You voted an amendment to the Constitution that it never should be changed on this subject. I quoted your own words and your own resolution, in which you declare that there is no party in the North worthy of consideration that has a purpose or design to interfere with the interests of the slave property of the South. We in the West were not content with this vote alone, and in order to be able to quiet our people, we asked you to pass a resolution in July last, declaratory of the purposes, objects, and intentions of this war, and the time when it should cease. That resolution was passed unanimously.

"What do we find is to-day the temper and disposition of a majority of this House? I call upon the gentleman who seems to be the leader of this measure to tell me if it is the purpose of the Secretary, and whether it is the intention of the Administration, to enter into a crusade by the power of the army; or whether you intend to force the Administration into a crusade, a John Brown raid, upon the negro property of the country? Is that your purpose? What does the gentleman mean by saying that we have 'a new problem to solve?' He says he cannot tell us how much money we owe, or how much it will require to develop the solution of this 'new problem'—the problem, I suppose, which has been put upon your record to-day. Not content with letting those who incited this war take the consequences and incidents of war in reference to their property, you propose to send your army and commissions into that country for the purpose of inviting the slaves of the peaceable and non-combatants into your lines, and free them, arm them, and turn them loose upon defenceless women and children, to commit rapine, murder, and conflagrations of defenceless habitations. When money appropriated for the war has been misapplied, law disregarded in its expenditure, I am opposed to giving more to be thus misused.

"What have you seen done here? The churches of the living God are taken for hospitals for the sick and wounded soldiers. I do not object to this if it is necessary. The Government is now occupying in the city, at high rent, a large tenement, in which are kept and supported four hundred (my friend says eight hundred) runaway negroes at the public expense. [A Voice: Eleven hundred.] Eleven hundred, I am told; I do not know. They are fed and clothed out of the money appropriated to feed and pay the soldiers."

Mr. Spaulding, of New York, replied, and then explained the power of Congress: "This bill is a necessary means of carrying into execution the powers granted in the Constitution 'to raise and support armies,' and 'to provide and maintain a navy.'

"In the present crisis of our national affairs it is necessary that the army should be 'supported,' and the navy 'maintained.' This necessity will not be questioned by any loyal member on this floor.

"The Constitution provides that 'all the laws necessary and proper for carrying into execution the foregoing powers' may be passed by Congress.

"If the end be legitimate, and within the scope of the Constitution, all the means that are appropriate, which are plainly adapted to that end, and which are not prohibited, may be constitutionally employed to carry it into effect.

"If a certain means to the exercise of any of the powers expressly given by the Constitution to the Government of the Union be an appropriate measure, not prohibited by the Constitution, the degree of its necessity is a question of legislative discretion, not of judicial cognizance.

"The Government of the United States is not prohibited by the Constitution from issuing Treasury notes on demand, and making them a legal tender in payment of all debts within its jurisdiction. The Constitution (article one, section ten) prohibits the States from making anything but gold and silver coin a legal tender in payment of debts; but this does not at all restrict the sovereign power of the United States. Congress has the power to coin money, 'regulate the value thereof, and of foreign coin.' Gold and silver by long practice—a practice that has continued for centuries among all nations—has become the legal money of the world in all commercial transactions. Its real intrinsic value is not as great as that fixed upon it by Governments. All Governments fix the value of gold and silver; and without their Government stamp gold and silver would be a simple commodity, like other things having intrinsic value. Some Governments fix the value of coin higher, and some lower; just as each for itself chooses to determine. Any other metal or thing that should be stamped, and its value regulated by all the Governments of the world, would pass equally well in all commercial transactions, as gold and silver, although not intrinsically as valuable. Exchequer bills or Treasury notes, whose value is fixed by Government, and stamped as money, would pass as money in the payment of debts within the jurisdiction of the Government fixing such value."

Mr. Pendleton, of Ohio, followed in opposition to the bill. He said: "I have examined, Mr. Chairman, with some care, every law authorizing the issue of Treasury notes which has been passed from the foundation of the Gov-

ernment up to this hour, and I find that this bill differs from all of them in several essential particulars. Every other law authorizing the issue of Treasury notes provided that they should bear some rate of interest, whereas these are to bear none; that they should be payable at a fixed time prescribed in the note, whereas these are only to be payable at the pleasure of the United States; that the notes thereby authorized should be receivable in payment of public debts only by those who were willing to receive them at par, while these notes are to be received by every public creditor who is not willing to forfeit his right to payment at all. These notes are to be made lawful money, and a legal tender in discharge of all pecuniary obligations, either by the Government or by individuals, a characteristic which has never been given to any note of the United States or any note of the Bank of the United States by any law ever passed. Not only, sir, was such a law never passed, but such a law was never voted on, never proposed, never introduced, never recommended by any Department of the Government; the measure was never seriously entertained in debate in either branch of Congress.

"The feature of this bill which first strikes every thinking man, even in these days of novelties, is the proposition that these notes shall be made a legal tender in discharge of all pecuniary obligations, as well those which have accrued in virtue of contracts already made as those which are yet to accrue in pursuance of contracts which shall hereafter be made. Do gentlemen appreciate the full import and meaning of that clause? Do they realize the full extent to which it will carry them? Every contract for the payment of money is in legal contemplation a contract for the payment of gold and silver coin. That is the measure of the obligation of the one party, and of the right of the other.

"The provisions of this bill contemplate impairing the obligation of every contract of that kind, and disturbing the basis upon which every judgment and decree and verdict has been entered. It proposes to say to a party who has entered into a contract, 'You shall be discharged from the obligations of that contract by doing something else than that which you have agreed to do.' It proposes to say to every party with whom a contract has been made, 'Though you are entitled to demand one thing, you shall, perforce, remain satisfied with the doing of another.' It proposes to say, 'Although you have agreed to pay gold and silver, you shall be discharged upon the payment of these notes; although you are entitled to demand gold and silver, you shall rest content with the reception of this paper.' It proposes, in one word, to release the one party from the obligation of his contract, and to divest the other party of the right which has been vested in him by that contract. Sir, I am sure I need only state the proposition to shock the mind of

the legal profession of the country, so thoroughly has it been imbued with the idea of the sanctity of the obligation of contracts by those who have taught it the beneficent maxims of constitutional law.

"As for the rest, this bill provides that it shall be illegal to make a contract for dealing in gold and silver coin; or, to state it more exactly, it provides that whatever executory contracts parties may make concerning the gold and silver coin of the country, they shall be discharged upon the performance of another and different duty—by the delivery of an equivalent number of dollars in these notes. Where, sir, does Congress get this power? Where is the grant to be found? One would suppose that a power like that—a power which involves the impairing of the obligations of such a vast class of contracts, which proposes to disturb vested rights to such an immense extent—would be worthy of a place in the express grants of the Constitution.

"Sir, it seems to me that if the language of the Constitution, and the weight of authority can settle any proposition, it is that Congress has not the power to do that which it is proposed shall be done by the provisions of this bill."

Mr. Hooper, of Massachusetts, stated that the financial plan of the Government embraced three measures: "The first of these measures is the one now before the House, by which the Secretary of the Treasury is authorized to issue United States notes, not to exceed \$150,000,000 in amount (including those authorized by previous laws), of denominations not less than five dollars. They are not to bear interest, but are to be issued and received as money, convertible, at the option of the holder, into six per cent. stock of the United States, the principal and interest being payable either here or abroad; and these notes are to be a legal tender.

"The second measure consists of a tax bill, which shall, with the tariff on imports, insure an annual revenue of at least \$150,000,000.

"The third is a national banking law, which will require the deposit of United States stock as security for the bank notes that are circulated as currency."

Mr. Morrill, of Vermont, opposed the bill, saying: "The subject of issuing \$150,000,000 of paper currency and making it a legal tender by the Government at a single bound—the precursor, as I fear, of a prolific brood of promises, no one of which is to be redeemed in the constitutional standard of the country—could not but arrest my attention; and, having strong convictions of the impolicy of the measure, I should feel that I utterly failed to discharge my duty if I did not attempt to find a stronger prop for our country to lean upon than this bill—a measure not blessed by one sound precedent, and damned by all."

Mr. R. Conkling, of New York, argued against the necessity for the measure, and, alluding to the power conferred by the Constitu-

tion for the issue of demand notes, said: "The proposition is a new one. No precedent can be urged in its favor; no suggestion of the existence of such a power can be found in the legislative history of the country; and I submit to my colleague, as a lawyer, the proposition that this amounts to affirmative authority of the highest kind against it. Had such a power lurked in the Constitution, as construed by those who ordained and administered it, we should find it so recorded. The occasion for resorting to it, or at least referring to it, has, we know, repeatedly arisen; and had such a power existed, it would have been recognized and acted on. It is hardly too much to say, therefore, that the uniform and universal judgment of statesmen, jurists, and lawyers has denied the constitutional right of Congress to make paper a legal tender for debts to any extent whatever. But more is claimed here than the right to create a legal tender heretofore unknown. The provision is not confined to transactions *in futuro*, but is retroactive in its scope. It reaches back and strikes at every existing pecuniary obligation. This was well put by the gentleman from Ohio (Mr. Pendleton), and I concur with him, that substituting anything for gold and silver in payment of debts, and still more of precedent debts, is of very doubtful constitutionality. But, in looking at the Federal Constitution, the question is: has the power been given; is it there? Can you put your finger upon it among the grants of the Constitution? If not, if it is not there at all, you have not the power, and there is an end of the whole matter."

Mr. Bingham, of Ohio, took the position that Congress had the power to declare what should be a legal tender, and said:

"In the first place, the Constitution has expressly provided that Congress shall have power to regulate commerce with all foreign nations, among the several States, and with the Indian tribes. This general provision of the Constitution has frequently undergone interpretation in our Supreme Court, and the effect of this language has been matter of deliberate consideration with every man who has ventured to issue a treatise upon the Constitution of the United States. Whoever takes the pains to look into either of these authorities—the decisions of the Supreme Court or the writers upon the true construction of the Constitution—will discover that they all agree in this, that this power to regulate commerce includes the exercise of all powers necessary to the existence of commerce among the several States, and extends even to its prohibition, when the public necessities require it. This, I undertake to say, is matter of agreement among all who have written upon the construction of the Constitution, and is substantially the ruling of the Supreme Court. Sir, if there were no limit in the Constitution upon this general power of Congress to regulate commerce, I would say at once that the Congress of the United States

might make anything money which it pleased. But there are certain limitations in the Constitution. Money has a twofold office. It determines the standard of value on the one hand, and it discharges obligations on the other. There is a limitation, and I am free to admit it. That brings me to the very pith and marrow of this debate.

"What is that limitation? That is the important point. I desired to-day to ask the attention of my excellent friend from Vermont (Mr. Morrill) to the question whether the Constitution of the United States has declared what shall be a legal tender. He did not find it convenient to yield to me for that inquiry. I stand here to assert that the Constitution of the United States has nowhere declared what shall be a legal tender. I stand here to assert further, that nothing has ever been made a legal tender in the United States at any time, in discharge of private obligations, or of public obligations, or of universal application in States and Territories alike, except that which was made so by act of Congress. Your Constitution, I repeat, never made gold and silver a legal tender. It never made anything a legal tender in the discharge of debts. The Constitution simply conferred the power on Congress by its general grants of power to declare by law what shall be a legal tender. Gold and silver and copper, if I recollect aright—and if I am wrong I hope the venerable chairman of the Committee of Ways and Means will correct me—have been all made alike legal tenders, at one time or other, by act of Congress."

Mr. Morrill, of Vermont, next rose and said: "I ask my friend from Ohio to point out as many words giving Congress the power to make paper money a legal tender. In relation to foreign coin, everybody who made a contract did so with his eyes open to the fact that Congress might make a change in regard to that matter. But when it comes to making paper money a legal tender, there is not a word in the Constitution about it."

Mr. Bingham, of Ohio, immediately replied: "Says the gentleman from Vermont (Mr. Morrill), 'I ask my friend from Ohio to point out as many words giving Congress power to make paper money a legal tender.'"

"Sir, the gentleman's question is answered by asking another of him: Point out the words in the Constitution giving to Congress the power to make gold or silver coin, either foreign or domestic, a legal tender. There are no such words. The gentleman seems to infer, because Congress is expressly authorized 'to regulate the value of foreign coin,' it is therefore in words authorized to declare foreign coin a legal tender. Such a conclusion is by no means self-evident. The Constitution declares that 'no State shall make anything but gold and silver coin a tender in payment of debts.' No one doubts, I presume, that any State of the Union may make the legalized gold and silver coin of

the United States 'a tender in payment of debts;' but does it thence result that a State may either regulate or change the established value of foreign or domestic coin? If any State could do this, the very purpose of the Constitution, to secure a uniform standard of value, would be defeated.

"The point I make is this: Congress has power, by the terms of the Constitution, to fix the standard value of foreign coin, and of domestic coin, and the power to declare a legal tender, and that these powers are distinct."

Mr. Vallandigham, of Ohio, rose to ask a question, saying: "Congress, is, by the Constitution, expressly empowered to regulate the value of coins. Now, I wish to ask my colleague whether the value thus regulated is not the legal value of the coin; and if therefore it is not a legal tender, although the word 'tender' is not written in the Constitution?"

Mr. Bingham, of Ohio, replied: "I agree that what Congress declares and enacts shall be the value of coin, is the legal value of such coin; but, sir, an act declaring the legal value of coin does not make it a legal tender."

Mr. Hickman, of Pennsylvania, now rose to inquire: "I desire to ask the gentleman from Ohio (Mr. Vallandigham) a simple question, with his permission. Taking the standard of gold and silver as it is established by law to-day, a contract is entered into for the payment of a debt in gold and silver at the present standard, that being by law a legal tender; but suppose the gold and silver should before the debt becomes due, by act of Congress, be debased thirty-three per cent., can that coin so debased be made a legal tender for the payment of that debt?"

Mr. Vallandigham replied: "It may be made a legal tender if Congress has the power to debase coin; but I deny that the power conferred by the Constitution on Congress to coin money and regulate the value thereof, confers the power to debase the coin of the country. There is no such power in Congress; and I think that is a sufficient answer to the gentleman's question."

Mr. Hickman, of Pennsylvania, again said: "Congress has, from time to time, changed the alloy of gold and silver coin. Now, if it may make coin so alloyed a legal tender in payment of a debt arising out of a contract, and in the mean time, before the debt becomes due, Congress again changes the alloy, debasing the coin to the extent of one third its value, can that coin so debased be made a legal tender in payment of that debt? Would not that, by the argument of the opponents of this bill, be as much a violation of that clause of the Constitution as to make paper a legal tender?"

Mr. Vallandigham now made this reply: "I answer, that if the purpose of the act of Congress be simply to change the alloy in order to harden the metal and make it more serviceable for the purposes of a currency, not to change its value, Congress has certainly

the right to do it; but because Congress has the implied right to do that under the power to coin money and regulate the value thereof, it does not follow that it may alloy the coin for the purpose of debasing it. The intent of the act makes the distinction."

Mr. Morrill, of Vermont, next rose to ask Mr. Hickman a question, saying: "If Congress have the power to debase the coin of the country by mixing with the gold and silver, in the shape of alloy, other metals, I desire to ask the gentleman from Pennsylvania if he derives from that fact the power of Congress to debase it in any other way."

Mr. Hickman thus replied: "The question I asked the gentleman from Ohio was in answer to the argument which has been made here by the opponents of this bill, that Congress can pass no law impairing the obligations of contracts; yet if a contract is made to-day by which I am to be paid a certain amount in the present standard of gold and silver coin, and to-morrow Congress passes a law debasing that coin thirty-three per cent., I am required to take that debased coin in payment of the debt, and my contract is thus impaired to the extent of thirty-three per cent."

Mr. Morrill further said: "I admit the power of Congress to debase the coin; but how would the gentleman derive from that power the power of Congress to substitute as a legal tender something else than coin?"

Mr. Thomas, of Massachusetts, now asked a question of Mr. Hickman, saying: "When the gentleman from Pennsylvania says the obligation of a contract is impaired, I want to ask him if in law this very essential provision of the Constitution does not enter into the contract, and if the contract must not conform to it? For instance, when a man agrees to take so much coin at a future day, he does it knowing that Congress has, by the Constitution, power to regulate and change the value of that coin."

Mr. Hickman, in answer, said: "Yes, sir, and for that reason, inasmuch as the Constitution allows us, as I contend, the power to issue paper money, the man who enters into a contract does it with the Constitution before him. Now, allow me in turn to put a question to the gentleman from Massachusetts. Suppose gold and silver should be discovered in such quantities in California, or within the limits of the United States, as to make it as plentiful as iron, as to make it useless as a money standard, I wish to know whether it is not in the power of Congress to substitute some other metal which may be more desirable as a circulating medium than gold?"

Mr. Thomas: "That question does not now arise."

Mr. Hickman: "If that power be conceded, then why not substitute paper, if that shall be found more useful for that purpose?"

Mr. Crisfield, of Maryland, said: "The sum of the whole argument that has been made in favor

of the constitutionality of the power of Congress to declare the Treasury notes contemplated by this bill a legal tender in the payment of all debts, public and private, may be stated in these three propositions: first, Congress may declare these notes a legal tender because it is not inhibited; secondly, the Government must maintain itself, and Congress may exercise all the power and adopt any measure it judges necessary for that object; and thirdly, that the power to declare these notes a legal tender is a means necessary and proper to the full execution of the power to regulate commerce.

"The Constitution found gold and silver coin the medium in which all contracts were to be settled. It recognized, but did not seek to disturb it. It gave Congress no power to disturb it, and inhibited the States from making anything else a tender in payment of debts. And we have no power to alter what the Constitution chose to leave untouched. We have no constitutional power to pass this bill."

Mr. Pike, of Maine, followed, saying: "In my judgment, any measure of finance now assumes the highest character. The existence of the Government depends upon a successful administration of the finances. Crippled here, we are balked everywhere. Upon the consideration of every financial measure there might well present itself anew the same question so fitly put by President Lincoln, in his message to Congress in July: 'Is it better to assume powers, the exercise of which shall violate a portion of the Constitution, rather than allow the whole to be destroyed?' and the country come to the paradoxical conclusion that it was his duty, as President, to violate the Constitution in order to preserve it.

"I trust that I have as much respect for that instrument as any man in the House; and it is because I would not have its authority over any portion of the Union impaired that I am bold in the exercise of power under it. But I would construe it in the light of the rule authoritatively announced for our action: 'The Sabbath was made for man, and not man for the Sabbath.'

"I have a high respect for the motives of gentlemen who discover so many constitutional objections to contemplated action; but for myself, I have concluded that whatever has a tendency to furnish means to suppress this rebellion, and affords a reasonable probability of hastening the consummation of what all loyal men so much desire, is perfectly constitutional. Nothing but an absolute prohibition would prevent me from adopting a measure which answers these conditions. I will never render to my people as a reason why I voted against such a measure that I deemed it unconstitutional, nor will I assist this Congress in proclaiming to the world and sending down to posterity the lack of constitutional power as a reason for failing to enact any law which will have a tendency to preserve this Union. This is no time

VOL. II—21 ▲

for the exercise of thin constitutional pedantry. Let us act boldly and forcibly, and so discharge the high and solemn duty imposed upon us infinitely better than if we shrunk from action under fear of constitutional scruples."

Mr. Alley, of Massachusetts, expressed his view of the constitutionality of the bill in these words: "This question of its constitutionality is hardly worthy of consideration in the face of the overshadowing necessities of the Government, for the reason that at most it can only be claimed as doubtful; for, to say the least, we have the authority of legal eminence as much in favor as against it; and every intelligent man knows, and will admit, outside of the legal profession, that legal enactments and constitutional provisions themselves have always in this country, whenever occasion required, with courts as well as statesmen, proved as packthreads upon the arms of an unshorn Samson before the resistless will of the people.

"No, sir; not a man will oppose this bill, or vote against it, upon any constitutional grounds, unless he is opposed to it for other and satisfactory reasons. This question of making paper money legal tender has never before been seriously entertained or discussed in this country since the adoption of the Federal Constitution, because the emergency has never before arisen to make it necessary."

Mr. Wright, of Pennsylvania, rose in opposition to the bill; he said: "Mr. Chairman, I have never been more embarrassed in my life as to how I should cast my vote than I am in regard to the vote I am about to cast upon this bill; for, as I live, I have no object or desire to embarrass the Government in regard to any of its measures, or the measures of any of the committees of this House, which have in view the putting down the rebellion now upon our hands. I am willing to do anything I constitutionally can, to bring about, that result which, of all others, is most desirable; but at the same time, Mr. Chairman, I have the obligations of a constitutional oath resting upon me. I do not desire, and it is not my intention, unless we arrive at a period when there are more difficulties surrounding us than there are now, to violate the obligations of that oath. If it is to be done, it must be done in a case of more extremity than we have now upon us.

"I was going on to state that I voted, during the extra session of Congress, to affirm the act of the President of the United States in the suspension of the writ of *habeas corpus*. I voted also to approve his act by which he declared certain of our seaports in a state of blockade. I also voted to approve his act declaring the establishment of military law. I did it for the sole reason that I regarded, at that time, that the exigency had arisen which justified us and the President of the United States himself in violating a constitutional provision. It was a vote *in extremis*. I voted the other day also to give the President of the United States the control of all the railroads in



the country for the transmission of troops. Nay, I went further than that, and voted for a clause in that bill which gave to the President the privilege of bringing into the public service the officers and employés of all the railroads of the country. I did that because it was an extreme case. And now we are called upon, according to the terms of this bill, to vote to declare it to be constitutional and legal to make paper itself money. Now, sir, I do not feel justified in going so far as to cast my vote for any such measure.

"It is said that this is among the great powers of the Government. Why, sir, all the powers this Government has under the Constitution are the powers delegated to it by the several States which thus met in Convention. There is no such thing in construing the Constitution as inference. There is nothing to be implied. The States that met together in convention clothed Congress with all the powers, in express terms, that Congress can legitimately exercise under the Constitution. Who doubts that? Who can gainsay that proposition? Not one iota of power does this Congress possess save what it derives under the Constitution. In plain terms have the States written their charter. It is in language not to be misunderstood. The powers of the General Government are expressed in the debates and votes of the men who gave it existence; in the decisions of the Supreme Court of the United States, and of the supreme courts of the several States; and in the views and votes of our predecessors in the halls of Congress. It seems to me that it is vain on our part to attempt to override these conclusions and to set them at naught, in the delusive idea that we have a clearer view and a keener perception of the powers with which this Government is clothed than had these worthy men who have gone before us.

"I lay down the principle that we are to conform our action to the Constitution of the country as it is, and I call upon gentlemen to show me how, when, where, in what particular, we have power, under the Constitution, to make anything, except gold and silver, a legal tender? I think, Mr. Chairman, it cannot be done. If it can be done, then courts, members of conventions, and the statesmen who have gone before us, have committed an egregious error, and we are coming now to perform the solemn act of condemning their judgment and of setting all their precedents at defiance."

Mr. Kellogg, of Illinois, said: "What is this legal tender? Is it found in the Constitution. Gentlemen seem to admit everywhere that gold and silver are a legal tender. I challenge any gentleman to put his finger upon the clause of the Constitution that expressly declares that anything shall be a legal tender, or that Congress shall have the power to make anything a legal tender. You cannot find it. Yet, sir, everybody seems to understand that gold and silver are a legal tender. What is it that the

Constitution declares? That Congress shall have power to regulate commerce, to coin money, and regulate the value thereof. What is this power of coining money and the regulation of the value thereof? Certainly the power to issue anything in the nature of coin that is to operate as a circulating medium. Gold and silver are not mentioned here, and there is not a gentleman who will not admit that the Government can coin and make money out of iron, or brass, or copper."

Mr. Thomas, of Massachusetts, followed on the other side. He said: "We look to the Constitution to see if the power is given. We do not say the power is not denied, and therefore exists; but that it is not granted, and therefore does not exist. The powers granted are express or implied, are given in terms, or are the reasonable inferences from the express grants. Now it is conceded that there is no express power given to Congress to make the notes or bills of the Government legal tender. There is a power given to Congress upon the subject-matter. It has the power to coin money, regulate the value thereof and of foreign coins.

"These words, 'to coin money,' have a plain and obvious meaning. The only coinage is that of the metals, 'hard money.' To coin money and regulate the value thereof is to fix its legal value, the value for which it is to be received, as an equivalent in commerce and in discharge of obligations and contracts. This constitutional power of coinage was first executed by the statute of 1792; and that statute has a provision making the coins legal tender; but there can be no doubt that whenever money is coined by Government under the Constitution it becomes *ipso facto* legal tender. But whether legislation be necessary to carry the provision into effect or not, it is too plain for argument that the power to coin money and regulate its value is the power to say for what value it shall be received.

"There being no express power in the Constitution to make the notes a legal tender, is such a power to be reasonably inferred from any of the express powers? Before answering this question, two things are to be observed.

"The first is that there being an express grant of power upon this subject of the coining of money and fixing its legal value, we should not reasonably expect to find an additional power on the same subject given by implication. The expression of the one would ordinarily be the exclusion of the other. The second thing to be noted is that it appears by the debates of the convention, and by the note of Mr. Madison, that this subject was before the convention, and that a grant of power to emit bills of credit, with the apparent purpose of making them legal tender, was refused.

"It is said that the power to make these notes a legal tender is a reasonable implication from the power to regulate commerce with foreign nations, among the States, and with the Indian tribes. The argument is, and it is

entitled to consideration, that money is one of the great instruments of commerce—as much so as the ship—and that the power to regulate the principal thing is the power to regulate its instrumentalities. I confess that at first this view of the question deeply impressed me. But further reflection has satisfied me it is not sound. If the Constitution were otherwise silent upon the subject, the implication would doubtless be a strong one.

“But the Constitution has spoken, has indicated what shall be money under its provisions, and the power of Congress over it.

“Again: the practical construction of the Constitution has been that no such power existed. Though the exigencies of the Government have heretofore been great, the experiment has never been tried, nor, so far as I know, ever before suggested.”

Mr. Edwards, of New Hampshire, in reply, said: “Why, sir, where is the express authority for the legislation—to seize upon an illustration nearest to us—under which this Capitol and all the spacious and durable public buildings around us have been provided for the uses of the Government; where is the express power for most of the details of all the Departments of the Government, for all the interests and security of commerce, for all the organization of your army and navy; not to extend this summary, where, sir, is the express power for doing that in which now this whole House unhesitatingly concurs, in the very bills before us? Nowhere in the Constitution. The emission of bills of credit, which these notes are, is nowhere named except as associated with the provision to make them a lawful tender, and to prohibit the States from doing either; and yet the power to emit bills of credit, when the necessity for its exercise arose in the war of 1812, found its recognition as a constitutional power, and has been acted upon as such at various periods without question.

“So, sir, the power which is now attempted to be exercised and to be deduced from the express powers granted would, in my belief, have found, as have other latent powers, a clear recognition, if the imperative necessity which is now upon us had ever earlier occurred.”

Mr. Blake, of Ohio, urged that the legal tender clause was constitutional because it was necessary, saying: “We say it is necessary to make Treasury notes a legal tender, and by it we intend to be understood to mean that the interests of the Government and the people require that it should be done. It is just in this sense the word necessary is used in the Constitution.”

Mr. Campbell, of Pennsylvania, also believed the necessity of the case secured its constitutionality. He said: “I humbly conceive my duty to be a plain one. The path I have marked out for myself I will follow, let it lead where it may. Whatever measure is now or hereafter may become necessary to adopt in order to maintain the

Union and perpetuate free government, that will I support. Speak not to me of ‘objections’ and ‘scruples’ and ‘dangers,’ of ‘constitutional objections’ and ‘conservative influences.’ Sophistry is ever plausible, and opposition to a just and necessary measure generally wears the mask of a ‘constitutional objection.’ The highest duty of every member is to maintain the Union—to sustain the Constitution against this causeless and wicked rebellion; and in doing this, let us bear in mind that the Constitution was made for the people—to secure to them and their posterity the blessings of free government. Therefore with me the primary inquiry is, Is this measure necessary to suppress the rebellion? If it is, here am I ready to sustain it. It will be found the Constitution gives ample power to sustain this view.”

Mr. Stevens, of Pennsylvania, thus examined the constitutional objections: “Having, as I think, shown the impossibility of carrying on the Government in any other way, let us briefly notice some of the objections to it. First, is it constitutional?

“The power to emit bills of credit and make them a legal tender is nowhere expressly given in the Constitution; but it is known that but few of the acts which Government can perform are specified in that instrument. It would require a volume larger than the Pandects of Justinian or the Code of Napoleon to make such enumeration, whereas our Constitution has but a few pages. But everything necessary to carry out the granted powers of the Government is not only implied but expressly given to Congress. If nothing could be done by Congress except what is enumerated in the Constitution, the Government could not live a week.

“The States are prohibited from making anything but ‘gold and silver coin a tender in the payment of debts;’ but such prohibition does not extend to Congress. The Constitution is silent as to the power of Congress over that subject. The whole question of the right to emit bills of credit by Congress was considered in the convention that framed the Constitution. It was reported as a part of the power ‘to borrow money.’ It was objected to as tending to make paper a currency with legal tender, and a motion was made to strike it out and insert an express prohibition. That was resisted, because, as Mr. Mason said, ‘it could not be foreseen what the necessities of the Government might at some time require.’ ‘The late war,’ he said, ‘could not have been carried on had such prohibition existed.’ It was finally agreed to strike out the express power, and not to insert the prohibition, leaving it to the exigencies of the times to determine its necessity. The right to emit bills of credit, which the convention expressly refused to grant as a substantive power, has for fifty years, by the common consent of the nation, been practised, and is now conceded by every opponent of this bill. With what grace can the concomitant power to make them a legal tender be objected to? The Su-

preme Court have settled certain principles with regard to the power of Congress over measures not expressly enumerated in the Constitution. The principle is, that where anything is necessary to carry into effect the granted power it is constitutional. The eighth section of the first article of the Constitution gives Congress power—

To make all laws which may be necessary and proper to carry into execution the foregoing powers, and all other powers vested by this Constitution in the United States or in any department or officer thereof.

"The Constitution nowhere gives Congress power to create corporations or to establish a bank of the United States. But as Congress had power to regulate commerce, and to regulate the value of coin, and it deemed the establishment of a bank necessary to effectuate those powers, the Supreme Court pronounced it constitutional. In short, whenever any law is necessary and proper to carry into execution any delegated power, such law is valid. That necessity need not be absolute, inevitable, and overwhelming—if it be useful, expedient, profitable, the necessity is within the constitutional meaning. Whether such necessity exists is solely for the decision of Congress. Their judgment is absolute and conclusive. If Congress should decide this measure to be necessary to a granted power, no department of the Government can rejudge it. The Supreme Court might think the judgment of Congress erroneous, but they could not review it. Now, it is for Congress to determine whether this bill is necessary 'to raise and support armies and navies, to borrow money, and provide for the general welfare.' They are all granted powers. It is for those who think that it is not 'necessary, useful, proper,' to propose some better means, and vote against this; if a majority think otherwise, its constitutionality is established."

The bill subsequently passed the House by the following vote:

YEAS.—Messrs. Aldrich, Alley, Arnold, Ashley, Bab-bitt, Goldsmith F. Bailey, Joseph Baily, Baker, Beaman, Bingham, Francis P. Blair, Jacob B. Blair, Samuel S. Blair, Blake, Buffinton, Burnham, Campbell, Chamberlin, Clark, Colfax, Cutler, Davis, Delano, Delaplaine, Duell, Dunn, Edgerton, Edwards, Ely, Fenton, Fessenden, Fisher, Franchot, Frank, Gooch, Granger, Gurley, Haight, Hale, Hanchett, Harrison, Hickman, Hooper, Hutchins, Julian, Kelley, Francis W. Kellogg, William Kellogg, Killinger, Lansing, Leary, Loomis, McKean, McKnight, McPherson, Marston, Maynard, Mitchell, Moorhead, Anson P. Morrill, Nugen, Olin, Patton, Timothy G. Phelps, Pike, Price, Alexander H. Rice, John H. Rice, Riddle, James S. Rollins, Sargent, Shanks, Shellabarger, Sherman, Sloan, Spaulding, John B. Steele, Stevens, Trimble, Trowbridge, Upton, Van Horn, Van Valkenburgh, Van Wyck, Verree, Wall, Wallace, Charles W. Walton, Whaley, Albert S. White, Wilson, Windom, and Worcester—93.

NAYS.—Messrs. Ancona, Baxter, Biddle, George H. Browne, Cobb, Frederick A. Conkling, Roscoe Conkling, Conway, Corning, Cox, Cravens, Crisfield, Diven, Dunlap, Elliot, English, Goodwin, Grider, Harding, Holman, Horton, Johnson, Knapp, Law, Lazear, Lovejoy, Mallory, May, Menzies, Justin S. Morrill, Morris, Nixon, Noble, Norton, Odell, Pendleton, Perry, Pome-

roy, Porter, Richardson, Robinson, Edward H. Rollins, Sedgwick, Sheffield, Shiel, William G. Steele, Stratton, Benjamin F. Thomas, Francis Thomas, Train, Vallandigham, Voorhees, Wadsworth, E. P. Walton, Ward, Webster, Chilton A. White, Wickliffe, and Wright—59.

On the 12th of February the bill came up in the Senate.

Mr. Fessenden, of Maine, having explained its features, thus argued the constitutionality of the legal tender clause: "The ground upon which this clause making these notes a legal tender is put, I have already stated. It is put upon the ground of absolute, overwhelming necessity; that the Government has now arrived at that point when it must have funds, and those funds are not to be obtained from ordinary sources, or from any of the expedients to which we have heretofore had recourse, and therefore this new, anomalous, and remarkable provision must be resorted to in order to enable the Government to pay off the debt that it now owes, and afford circulation which will be available for other purposes. The question then is, Does the necessity exist? That is a question which I propose in some degree to discuss, because I admit fully and decidedly that the Government, or the country, rather, is to be sustained in its present undertaking, and that we are bound to obtain the means to effect that object. If the necessity exists, I have no hesitation upon the subject, and shall have none. If there is nothing left for us to do but that, and that will effect the object, I am perfectly willing to do that."

Mr. Collamer, of Vermont, replied: "If I understand him, he says that if there is a necessity for the issuing of this paper and making it a legal tender, he is ready to vote for it. I differ from the Senator there, to begin with. I do not know how other members of the Senate look upon the obligation of their oath to support the Constitution of the United States. To me it is an oath registered in heaven as well as upon earth, and there is no necessity that in my estimation will justify me in the breach of it. I think those men who are now risking their lives upon the high places of the field to support the Constitution, are not to be treated in this hall by us with the concession that we are ready, if the necessity calls for it, to break it. All that our rebel enemies are engaged in is the overthrow of the Constitution, and all that we are contending for is its maintenance and preservation. Let the necessity be what it may, I cannot disregard the obligation of my oath to support the Constitution; and it is mainly with a view to ascertain what is the true meaning of the Constitution upon this subject that my remarks are presented, though other things will run parallel with that tending to the same result.

"But, sir the more important feature to which I wish to call attention is that the bill proposes to make these notes a legal tender in payment of private debts between man and man, with which the Government has nothing

to do. Why is this? What is the object intended to be effected by making these notes thus a tender in payment of private debts? I have before me a letter addressed by the Secretary of the Treasury, Mr. Chase, to a Representative in the other House, and which was used in that body, from which I wish to read for the purpose of seeing what is the object to be effected, and why it is to be effected. Speaking of these notes, he says:

The making them a legal tender, however, might still be avoided, if the willingness manifested by the people generally, by railroad companies, and by many of the banking institutions, to receive and pay them as money in all transactions were absolutely or practically universal; but, unfortunately, there are some persons and some institutions which refuse to receive and pay them, and whose action tends not merely to the unnecessary depreciation of these notes, but to establish discrimination in business against those who, in this matter, give their cordial support to the Government, and in favor of those who do not make such discrimination. This, if possible, should be prevented, and a provision making notes a legal tender, in a great measure at least, prevents it, by putting all citizens in this respect on the same level, both of rights and duties.

"There is the statement. This feature of the bill is ingrafted on it for the purpose of making the thing precisely equal, and operating alike on all citizens of the community. Now, what does the word 'tender' mean? I do not speak of it as an adjective; I speak of it as a noun, a substantive. It means an attempt at payment, an offer of payment of a debt due. It applies to nothing else. Here comes a distinction which, it seems to me, has hardly been looked at, in the importance in which I view it, in all the discussions in the House of Representatives. Who, under this bill, is compelled to take this paper called money? Nobody but those who have debts due them. Nobody is compelled to take it for his property. Tender cannot be made to a man to obtain his horse from him. He has a horse to sell, he has flour to sell, merchandise to sell, work to perform, labor to do; you cannot make a tender to a man for any of these things. In all the great general affairs of life, this provision, made, as it is said, to make men equal, can never have any application to them. It applies to nobody except some man who has been so unfortunate as to incur the public displeasure because he has saved a little money from his industry, and has it in the form of a debt due him. It is none but such an unfortunate man that can be reached by this provision, and that is called making things equal! I do not know what opinions other men may have about equality. I have heard that equality was equity. If they are convertible terms, I say that is not equality nor equity either. The number of people who owe debts in every community is very much larger than those who have debts due to them. To all those people you address yourself by this tender clause, saying, 'We engage all of you who owe debts to depreciate this paper as much as you can and

get it as cheap as you can, to cheat your creditors with.' That is enlisting a very great aid, I take it, to the currency of this paper.

"Mr. President, where is the power to do this derived from? It is said to be an incidental power, falling within that provision of the Constitution giving Congress authority to make all the laws which are necessary and proper to carry into effect the granted powers. When gentlemen desire to get some latitude and elbow room for action, I know that they are generally exceedingly desirous to get a thing into that category. If you can only get the power into that incidental clause, you have plenty of elasticity. It has so much India-rubber substance in it that you can take just as much elbow room as you want. There is, therefore, in those who desire to magnify their office and their power, a very strong inclination to resort to this clause.

"It is said to be incidental to a great variety of powers. It is said that Congress has power to raise and support armies, *ergo* the incidental power to raise money in this form or any other form for the purpose of supporting armies! So it is said that the Government has power to pay its debts, *ergo* we may raise money in this way! The most general packhorse for this incidental power, however, has been the authority given to Congress by the Constitution to regulate commerce, and this power is said to be derived from that. I have heard some considerable latitude of argument about that. But, sir, what is the power of Congress to regulate commerce? The Constitution says that Congress may 'regulate commerce with foreign nations, and among the several States, and with the Indian tribes.' Here is a bill authorizing the issue of Treasury notes and making them a tender in payment of debts. I want to know what that has to do with trade between the States? To my mind that, if it is doing anything, is regulating trade between me and my neighbor in the same State, not regulating trade between separate States, and not regulating foreign trade. It is merely regulating a shaving trade between debtor and creditor. The bill proposes to make these notes a tender to pass as the representative of value in trade between man and man. Under this clause of the Constitution, it might be proposed to adopt some measure for a commercial agency or commercial functionary; but if you make paper a tender, as I have before remarked, nobody will be bound to take it in exchange for property. Then it cannot be a measure of regulating commerce. It will not regulate it at all."

Mr. Wilson, of Massachusetts, thus expressed his views on this point: "It is not my purpose to say anything in regard to the constitutional question. Senators of eminent ability differ upon that question; men eminent in constitutional law, in and out of Congress, differ upon that question; and when the most eminent constitutional lawyers of the country

differ in regard to a question of that importance and of that character, it seems to me that those of us who choose to do so may exercise our own judgments in regard to the constitutionality of the measure."

Mr. Sherman, of Ohio, followed. He said: "I agree that this measure can only be justified on the ground of necessity. I do believe there is a pressing necessity that these demand notes should be made a legal tender if we want to avoid the evils of a depreciated, dishonored paper currency. I do believe we have the constitutional power to pass such a provision, and that the public safety now demands its exercise. Is there such a necessity?"

Mr. Cowan, of Pennsylvania, followed, saying: "I had supposed, sir, that this question could never enter the American Senate; that the day had gone by when it was open to discussion, if it ever was open since the Constitution was formed. Surely, if anything in the world is settled—settled by the fathers, by contemporary history, painful experience, and the total absence of all precedent for the exercise of these powers—it is that they were not delegated nor intended to be delegated. I have never till now heard it doubted; and after the argument of the learned and venerable Senator from Vermont, I think no one of us, looking at it in the light of the oath he has taken, could doubt it. If this is not settled, then is nothing settled, and we are all at sea.

"It may be superfluous, Mr. President, but still I think proper to recur a moment to first principles upon this question—whether the United States Government can make its notes a legal tender in payment of debts—and in so doing, I think it will be found, if answered in the affirmative, that the power would be subversive of all our notions of government and the ends for which it is established, which are the protection and preservation of society."

Mr. Bayard, of Delaware, followed in opposition to the bill. He said: "I shall pass over the constitutional argument. I really do not think, from anything I ever heard on the subject, that it is worth an argument. The thing is to my mind so palpable a violation of the Federal Constitution, that I doubt whether in any court of justice in this country, having a decent regard to its own respectability, you can possibly expect that this bill which you now pass will not, whenever the question is presented judicially, receive its condemnation as unconstitutional and void in this clause."

Mr. Howard, of Michigan, on the other side of the question, thus expressed his views: "We have under the Constitution the power to borrow money. This no one disputes. If we have the power to borrow money, we have the right; and it is our duty to place in the hand of the lender an evidence of the fact that we have so borrowed it, and, further, that we intend to pay what we have borrowed. These two things are manifestly, in their very nature, inseparable; and the only real question, it

seems to me, which addresses itself to the Senate, is this: whether we have any power, after having issued this description of paper to the public creditors in payment of their debts, to protect the credit of the United States expressed upon the face of the paper, while it is in the hands of innocent and honest holders. I think we have. I think this is one of the most obvious means of extending protection to the public credit thus expressed upon the paper. If we have it not; if we cannot subject, so to speak, the entire property of the nation to something like an assistance to the public credit, then this power to borrow money at once ceases to be a power of any value, and it is a mere mockery upon the face of the Constitution. If we cannot declare that this paper shall in commercial transactions be of equal validity to transactions based upon gold and silver, then I say that the power to borrow money ceases in and of itself to be of any benefit to the Government or to the nation; and it is because I believe that we have this power thus to protect the public credit, expressed and pledged on the face of a Treasury note, that I shall vote to retain this clause in the bill. I think we have the constitutional power, and I am willing to use it on this occasion."

Mr. Sumner, of Massachusetts, argued that the measure was not unconstitutional, saying: "It is true that in the Constitution there are no words expressly giving to Congress the power to make Treasury notes a legal tender; but there are no words expressly giving to Congress the power to issue Treasury notes. If we consult the text of the Constitution, we shall find it as silent with regard to one as with regard to the other. But, on the other hand, the States are expressly prohibited to 'emit bills of credit, or make anything but gold and silver coin a tender in payment of debts.' Treasury notes are 'bills of credit;' and this prohibition is imperative on the States. But the inference is just that this prohibition, expressly addressed to the States, was not intended to embrace Congress indirectly, as it obviously does not embrace it directly. The presence of the prohibition, however, shows that the subject was in the minds of the framers of the Constitution. If they failed to extend it still further, it is reasonable to conclude that they left the whole subject in all its bearings to the sound discretion of Congress, under the ample powers intrusted to it.

"If the Constitution failed to speak, Congress has not failed; and the exercise of this power cannot now be questioned without unsettling our whole financial system. But we have seen that throughout our colonial history the legal tender was a constant, though not inseparable, incident to the bill of credit; that, indeed, it was so much a part of the bill of credit that the Imperial Parliament positively interfered to separate the two, and, while sanctioning the bill of credit, forbade the tender. And now, if this historical review is properly apprehend-

ed—if it is not entirely out of place—it must conduct to the conclusion that, whatever may be the present question of policy, the power to make Treasury notes a legal tender has precisely the same origin in the Constitution with the power to create Treasury notes. It is true that you may exercise one power, and decline to exercise the other; but if you assume the power to issue bills of credit, I am at a loss to understand how you can deny the power to make them a legal tender. The two spring from the same fountain. You may refuse to exercise one or both; but you cannot insist upon one under the Constitution and reject the other.”

A vote was then taken on a motion to strike out the legal tender clause, which resulted as follows:

**YEAS.**—Messrs. Anthony, Bayard, Collamer, Cowan, Feasenden, Foot, Foster, Kennedy, King, Latham, Neamith, Pearce, Powell, Saulsbury, Simmons, Thomson, and Willey—17.

**NAYS.**—Messrs. Chandler, Clark, Davis, Dixon, Doolittle, Harlan, Harris, Henderson, Howard, Howe, Lane of Indiana, McDougall, Morrill, Pomeroy, Rice, Sherman, Sumner, Ten Eyck, Wade, Wilkinson, Wilson of Massachusetts, and Wilson of Missouri—22.

The bill was subsequently passed by the following vote:

**YEAS.**—Messrs. Anthony, Chandler, Clark, Davis, Dixon, Doolittle, Feasenden, Foot, Foster, Grimes, Hale, Harlan, Harris, Henderson, Howard, Howe, Lane of Indiana, Latham, McDougall, Morrill, Pomeroy, Rice, Sherman, Sumner, Ten Eyck, Trumbull, Wade, Wilkinson, Wilson of Massachusetts, and Wilson of Missouri—30.

**NAYS.**—Messrs. Collamer, Cowan, Kennedy, King, Pearce, Powell, and Saulsbury—7.

In the senate, on the 28th of January, on motion of Mr. Wade, of Ohio, the bill to authorize the President of the United States in certain cases to take possession of railroad and telegraph lines was taken up. The bill proposed to authorize the President of the United States, when, in his judgment, the public safety might require it, to take possession of any or all the telegraph lines in the United States, their offices and appurtenances; to take possession of any or all the railroad lines in the United States, their rolling stock, their offices, shops, buildings, and all their appurtenances; to prescribe rules and regulations for the holding, using, and maintaining of the telegraph and railroad lines in the manner most conducive to the safety and interest of Government; to place under military control all the officers, agents, and employes belonging to the telegraph and railroad lines thus taken possession of, so that they should be considered a part of the military force of the United States, subject to all the restrictions imposed by the rules and articles of war. Any attempt, by any party or parties whomsoever, to resist or interfere with the unrestrained use by Government of the property thus taken possession of, or any attempt to injure or destroy it, was to be pun-

ished as a military offence by death or such other penalty as a court martial may impose.

Three commissioners were to be appointed by the President, by and with the advice and consent of the Senate, to assess and determine the damages suffered, or the compensation to which any railroad or telegraph company might be entitled, by reason of the railroad or telegraph line being seized and used under the authority conferred by the act, and their award was to be final, and the amount was to be paid to the party entitled to it out of any money in the Treasury not otherwise appropriated.

The transportation of troops, munitions of war, equipments, military property and stores throughout the United States, was to be under the immediate control and supervision of the Secretary of War, and such agents as he might appoint.

The compensation of each of the commissioners was to be eight dollars per day while in actual service, and the provisions of the act were not to be in force any longer than was necessary to bring the war to an end.

Mr. Cowan, of Pennsylvania, said: “The bill contemplates that, under certain contingencies, the military force of the country may take possession of the railroads and telegraph lines of the country. This, I have no doubt, is proper, and, under the right of eminent domain, I have no doubt the Government has power to authorize it; but who shall decide upon the contingency? The owners of these roads may be citizens having rights which are secured and guaranteed to them under the fifth amendment of the Constitution, and they have a right to appeal to the courts, I should think, in order to determine whether those rights were or were not violated by the military officers in taking possession of their property at that time for public use.

“Why, it may be asked, are persons in the land and naval forces subjected to military punishment for offences? It is because they have waived their constitutional rights by subscribing at the time they entered this force to the rules and regulations laid down by Congress for the government of the land and naval forces; and I very much doubt whether a man could be subjected to the peculiar punishment there inflicted, unless he had first subscribed to those articles. Certainly, when a man enters the army, he is called upon and he does agree to those rules and regulations, which are outside of the course of the common law, and which do not proceed by due process of law, before he can be held answerable.”

Mr. Trumbull, of Illinois, followed, saying: “The Senator from Ohio says that it would be impossible in districts where railroads would probably be taken possession of to impanel juries and try the parties resisting that possession. That is very true; it would be; and it is not necessary to do it there. Now, the distinction which I make, and the basis of the bill which has been introduced here to confiscate

the property of rebels goes upon this idea: that the Constitution of the United States, which guarantees a jury trial, and which declares that no man shall be deprived of life, liberty, or property without due process of law, has no application whatever to a district of country where the judicial tribunals are utterly overthrown, and where the military power is called in for the purpose of putting down an insurrection, just because the judicial authorities are overthrown. That is the very point where the military may begin to operate."

Mr. Pearce, of Maryland, expressed his astonishment at the bill, saying: "It seems to me that this bill is a very extraordinary one. It has taken me by surprise. I believe that it was only laid on our tables yesterday. If it were confined to the States in secession I should make no objection; but I confess I am appalled with the idea of giving the Executive such an enormous power as this over States which are not in insurrection, which may not be in insurrection, and in which there is not a fortieth part of the people who desired it ever should get into insurrection."

Mr. Pearce also said: "But further, sir—you authorize them to place under military control all the officers, agents, and employes belonging to the telegraphs and railroads thus taken possession of by the Government, so that they shall be considered a part of the military forces of the United States, subject to all the liabilities imposed by the rules and articles of war. Where do you get the authority to make these civil employes of these railroads subject to the rules and articles of war? They are only military men who are subject to them. These persons have not made themselves subject to them by enlisting in the military service of the United States, or by volunteering into its service, or by being drafted into the militia; and yet you take these poor civilians, the whole business of whose lives is railroad transportation for passengers and freight, and make them subjects of military law."

Mr. Davis, of Kentucky, was of the opinion that the exception taken to the bill by the Senator from Maryland was well taken. He said: "He objects to that portion of it which proposes 'to place under military control all the officers, agents, and employes belonging to the telegraph and railroad lines thus taken possession of by the President.' I say that that is wholly an unauthorized power. Congress, the law-making power of the United States, cannot invest the President with that authority. He has no right to assume that persons who are in civil employment, either in a State or in a State corporation, or in their own private and individual capacity, can be seized by authority of a law of Congress, and appropriated to and made a part of the military power of the United States, and subjected to the military law. I utterly deny that that is constitutional."

Mr. Trumbull, of Illinois, thus expressed his

opinion: "I am for punishing a man in the loyal States who interferes with a telegraph line or a railroad line as severely as in the disloyal States. I am for punishing them all. The constitutional point is simply this: can you punish a citizen by military court martial in a loyal portion of the country?"

Mr. Wilson, of Massachusetts, followed: "What is the whole object of this bill? What is the reason why it has been introduced here, and why does the new Secretary of War desire a measure of this kind? We have assembled large armies; it is expected that these armies are to move; the public voice demands action; they have to move over vast spaces of country; railways must be a great means of transportation for them. Now, the object is to have the control of the railway lines for the purpose of moving these masses of men. The object is to concentrate our forces, to move large masses of men without the knowledge or consent of anybody, without negotiating with railway directors as to how many men are to be moved, or where they are to be moved, or what rolling stock is wanted, or anything of the kind."

Mr. Hale, of New Hampshire, said: "It is unquestionably true that the power to do these things exists at the present time. Nobody can doubt—not even my friend from Maryland, who says that he is appalled by the principles enunciated by this bill—that, in a time of war, when the necessity exists, the Government may seize upon property; may seize upon men; may seize upon anything and everything which is necessary to accomplish its war purposes. In seizing private property your authorities do not stop to call a jury to estimate its value under that clause of the Constitution which provides that private property shall not be taken for public use without compensation. They take it when the necessity arises; take the man, the horse, the grain, the railroad, the large thing as well as the small. There is no doubt about the power."

Mr. Fessenden, of Maine, said: "If you mean only to give power to impress a certain class of your fellow citizens, under a given state of facts, into the military service of the country, I am willing to do it if it is recommended by the proper authorities, and it is thought advisable that it should be done by general law, instead of leaving the power to be exercised in each case where an emergency may present itself. We have just as much right to consider men who are employed for the purpose of this bill, in the military service, as to provide that men shall be drafted for our armies. That is a power that exists in the Government, undoubtedly. It is within the war-making power; and if that is the design, I do not know that I have any objection so far as that point goes."

Mr. Wade, of Ohio, argued in reply: "The Senator declared that the war power was vested in the President. There is no such power as that in the President. It is in the Congress—in the representatives of the people and of the

States. To place it anywhere else would lead you directly to an irresponsible despotism. Sir, as a representative of a State of this Union, I will never consent to yield my right to declare upon this floor upon what principles any war shall be conducted. I deny the right of the President, without any interference of Congress, to conduct everything pertaining to war according to his own views. He has no right to do it. We have seen the trouble that has been occasioned by an attempt to exercise a power that he probably has, in a way not regulated by law, and it has greatly impaired his authority, if not his good name abroad. Look at the complaints against him because he has undertaken to suspend the *habeas corpus*, a power not regulated by law. Ought not that power to be regulated by law like every other? Would it not be better for your Executive that it should be so? Ought we, the representatives of the people and of the States, to shrink from declaring upon what principles men may be deprived of their liberty? I do not say this in any sense of denunciation against what has been done, because there has been a necessity for it. We create and continue that necessity every hour that we fail to declare on what principles a man may be taken and deprived of his liberty.

"Now, sir, I am as anxious as any other man to defend the rights of the people, and to confer the proper authority upon the Executive to act; but I absolutely deny that without our assent he may exercise just what powers he pleases in respect to the conduct of this war. We, the representatives of the States and the representatives of the people, whose interests and whose persons are affected by the war, have the right here to limit the powers that he shall exercise upon just such subjects as we see fit, just as we please, and when we please; and because, in my judgment, he has not this unlimited power to exercise, except from necessity, when we fail to act, the duty is devolved upon us of prescribing the rules under which he shall act, and therefore I have brought forward this bill."

Mr. Doolittle, of Wisconsin, continuing the debate, said: "Mr. President, in the course of this discussion we have come up against the great question that divides the judicial minds of the country, whether the power of suspending the *habeas corpus* and of declaring martial law is in the President or in Congress. If it is in the President, no legislation whatever would be necessary, because the President can extend his martial law anywhere throughout the United States, over every railroad in it; and any man who commits an offence upon the railroad over which martial law is extended can be tried by martial law, and shot at a drum-head court martial. But inasmuch as there is a large and respectable portion of the judicial minds of the country who believe that it belongs to Congress to extend martial law in the United States, therefore I understand this committee, for greater security and caution, to have both

the authority of the President and the authority of Congress, ask for the provisions of this bill, which are nothing more nor less than to extend martial law, or *quasi* martial law, over the railroads and telegraphs of the United States.

"Why should we hesitate to give it? The Senator from Maine insists that the President has it now. What harm is it, then, if Congress says he shall have it?"

Mr. Cowan, of Pennsylvania, followed in a lengthy speech. His view was thus expressed: "I do not think this bill is necessary. I think that all laws of this kind which are calculated to enlarge the power of the President as Commander-in-Chief of the Army, will in the end only be found to impede his march, and involve not merely himself but Congress and everybody else in trouble. He had better be left to the exercise of that absolute power with which he is clothed, within its limits free to act, free to do everything. I should be sorry if he had not done everything that was necessary and that he had a right to do; but I suppose, if not now, it will soon be found out.

"I am opposed to the whole scheme; but if there is to be a law of this kind at all, it ought to be so well considered as to at least keep us who legislate for the citizen, who has a right to have the laws administered through the medium of the judiciary, clearly within the limits of the Constitution. I would not throw a straw in the way of the President; and why? In what way am I to carry that out? By not passing laws—not by passing them. The men who are giving the President a full and fair opportunity with the military force of the nation to put down the rebellion are those men who do not restrain him, who do not fetter him, but who leave him as the commander-in-chief of an army ought to be left, to do that which in his own discretion and good judgment he ought to do, and let him take the responsibility."

Mr. Bayard, of Delaware, in opposition to the bill, said: "I do not rise for the purpose of opposing this bill. I shall vote against it. I consider it a plain and palpable violation of the Constitution of the United States. I know of no power, executive or legislative, to establish martial law within the United States. I therefore have no comments to make upon this bill. The provisions of it speak for themselves. It assumes the power to compel citizens of the United States to act under military law without their consent, and subjects them to the penalties of military law. Though the Constitution says that private property shall not be taken for public purposes without compensation, it assumes the power, not to seize private property, but the power to use it temporarily for Government purposes without compensation for the value of the property.

"Sir, in all these cases it is the first step which costs. Once accustom the people of this country—I do not care under what plea, whether of state necessity, or putting down of rebellion, or what you will—that within that por-



tion of the United States in which the laws are not suspended, in which civil remedies can be afforded, the civil power is subordinate to the military, and there is an end of civil liberty; there is an end to republican government. You may talk about fighting for the restoration of the Union; but if your restoration of the Union is merely for the acquisition of power, apart from the preservation of the Constitution and the principles of liberty on which that Constitution is founded, is it worth the struggle and the destruction of human life which will ensue in consequence? Is it for mere conquest that you are fighting, or is it to preserve the Union, because the Union is to save the great principles of civil liberty upon which that Union is based?

"I deny the principle on any possible ground of legal construction, consistent with the Constitution and the preservation of civil as opposed to military authority, where the laws of the United States can be executed by the civil power, that you have the right to interpose military power and to override the civil power, because you may think it more convenient.

"Mr. President, this doctrine of State necessity is at all times a dangerous doctrine. In truth, the whole question comes to this: There are in reality but two forms of government: one is a government of will, and the other a government of laws. The United States profess to have a government of laws. If you transfer that power, no matter under what plea, no matter under what necessity or what excuse, so that the mere will of the Executive or of his subordinate military commanders can, without the laws which secure the rights of individuals, trespass upon personal liberty, and upon the rights of private property, where those laws are enforced, there is an end of republican government; there is an end of a government of laws. There is the substitution of a government of will, and that is a despotism wherever it exists."

The bill was finally passed by the following vote:

**YEAS.**—Messrs. Carlile, Chandler, Clark, Dixon, Doolittle, Foot, Hale, Howard, Howe, Johnson, King, Lane of Indiana, Latham, Pomeroy, Rice, Sherman, Sumner, Ten Eyck, Wade, Wilkinson, Willmot, Wilson of Massachusetts, and Wilson of Missouri—23.

**NAYS.**—Messrs. Browning, Cowan, Davis, Fessenden, Foster, Grimes, Harris, McDougall, Powell, Saulsbury, Trumbull, and Willey—12.

The expulsion of all members of the Senate who had either united with the Southern Confederacy, or who had said or done anything not strictly loyal, in the opinion of Senators, caused very extended debates during this session. The points embraced in each case are here shown. In this crisis of the country all measures were considered necessary which might remove some real or apprehended danger.

In the Senate, on the 10th of January, the resolution relative to the expulsion from the

Senate of Waldo P. Johnson, Senator from Missouri, was taken up and the report of the committee made as follows:

The Committee on the Judiciary, to whom was referred a resolution for the expulsion from the Senate of Waldo P. Johnson, a Senator from the State of Missouri, submit the following report:

Previous to his election to the Senate, Mr. Johnson was known, in Missouri, as entertaining secession proclivities, and to sympathize and cooperate with the prominent citizens of that State who are now in open rebellion against the Government. He was elected to the Senate by a Legislature which has since sought to array the State against the Union. Since his election he is reported to have made a speech evincing a spirit hostile to the Government, which speech was extensively published in the State of Missouri without public contradiction from him. He has not appeared in his seat in the Senate since the session began; and though the resolution for his expulsion was proposed in the Senate on the 10th day of December, and referred to this committee on the 12th day of December, 1861, and has been extensively published in Missouri and other parts of the Union, the said Johnson has wholly failed to furnish any reason for his absence, or explanation of the charges of disloyalty urged against him.

The failure of said Johnson for so long a period to appear in his place to discharge the high duties incumbent upon him for the preservation of the Republic in this time of rebellion against its authority, and his silence under the imputations upon his loyalty, which, from their publicity, could not have escaped his notice if within a loyal portion of the Union, of themselves furnish strong presumptive grounds against his fidelity to the Government.

His whereabouts at this time the committee have been unable, with actual certainty, to ascertain. They are satisfied that, had he been so disposed, there was nothing to prevent his attendance on the Senate at its commencement; and when last heard from, he was reported to have gone voluntarily within the lines of rebels in arms against the Government.

Under these circumstances, the committee are of the opinion that he ought to be expelled from the body, and they accordingly report the resolution back to the Senate, with a recommendation that it do pass.

Mr. Bayard, of Delaware, said: "For my own part I have read too much of the past history of the world to condemn men merely for opinions, however widely they may differ from my own; but acts are another thing. The evidence in this case satisfied me that Mr. Johnson had left the United States clandestinely, and that every rational presumption was that he had gone to the Confederate States, who now are at open war with the United States. Under these circumstances, I have no hesitation in giving my vote for his expulsion as a member of this body."

The resolution was then adopted by a unanimous vote.

The resolution relative to the expulsion of Senator Trusten Polk was then taken up, and the committee submitted their report as follows:

The Committee on the Judiciary, to whom was referred the resolution of the Senate for the expulsion of Trusten Polk, a Senator from the State of Missouri, report:

That it appears, to the satisfaction of the committee, that Trusten Polk recently, and since the commencement of the present rebellion, in a letter transmitting pecuniary means to aid in the publication of a secession newspaper in Southwestern Missouri, among other

dialoyal and treasonable expressions, used the following:

"Dissolution is now a fact; not only a fact accomplished but thrice repeated. Everything here looks like inevitable and final dissolution. Will Missouri hesitate a moment to go with her southern sisters? I hope not. Please let me hear from you. I would be glad to keep posted as to the condition of things in Southwest Missouri. I like Governor Jackson's position. It looks like adherence to the 'Jackson resolutions.'"

That a copy of this letter was published in full in the Congressional Globe of the 19th of December last, the day after the resolution of expulsion, in this case, was introduced in the Senate, and has, also, both before and since that time, been published and referred to in several other newspapers in Missouri and elsewhere, and widely circulated throughout the country, which publication could hardly have failed to come to the notice of Senator Polk; and yet neither he, nor any other person in his behalf, has appeared before the committee to deny the authenticity of the letter referred to, or attempted in any other way to deny or explain it, so far as the committee are aware—a course of conduct deemed to be wholly incompatible with the idea of his innocence, since an innocent man, in his position, according to the first impulses of a true and loyal heart, would not have suffered a moment to elapse without flying to his place to deny, if false, so grave and foul a charge.

That besides this, he has not only failed to appear in his seat during the whole time of the continuance of the present session, now a period of six weeks, to perform his duty to his State and to the Union, on an occasion of the greatest possible urgency, when the votes as well as counsel of every true and loyal Senator were eminently needed in providing for the public welfare and putting down a fierce rebellion, threatening the very existence of the Union, but on the contrary, as the committee are fully satisfied on information derived from reliable official and other sources in Missouri, has left his home in St. Louis and gone clandestinely within the lines of the enemy now in open, armed rebellion against the United States, whose Constitution he, as Senator, has solemnly sworn to support.

The committee, under this state of facts, are of opinion that justice to the Senate, to rid its roll of his name, as well as the chamber of his presence; justice to the State of Missouri, whose high commission he has dishonored; and justice to the Union, which he has sought to betray, all require that he should no longer continue a member of this body.

They therefore respectfully report the resolution for the expulsion of Truett Polk, a Senator from Missouri, back to the Senate, with the unanimous recommendation that the same do pass.

It was then unanimously passed.

The Committee of the Judiciary, to whom was referred a resolution to expel Jesse D. Bright, Senator from Indiana, reported on the 13th of January, as follows:

The Committee on the Judiciary, to which was referred a resolution to expel Hon. Jesse D. Bright from his seat in the United States Senate, respectfully report:

That they are of opinion that the facts charged against Mr. Bright are not sufficient to warrant his expulsion from the Senate; and they therefore recommend that the resolution do not pass.

The further consideration of the subject was postponed.

On the 20th the subject was again taken up.

The resolution which was introduced by Mr. Wilkinson, of Minnesota, upon which the committee reported, was as follows:

Whereas Hon. Jesse D. Bright heretofore, on the 1st day of March, 1861, wrote a letter, of which the following is a copy:

WASHINGTON, March 1, 1861.

MY DEAR SIR: Allow me to introduce to your acquaintance my friend Thomas B. Lincoln, of Texas. He visits your capital mainly to dispose of what he regards a great improvement in firearms. I recommend him to your favorable consideration as a gentleman of the first respectability, and reliable in every respect.

Very truly, yours, JESSE D. BRIGHT.

To His Excellency JEFFERSON DAVIS,  
President of the Confederation of States.

And whereas we believe the said letter is evidence of disloyalty to the United States, and is calculated to give aid and comfort to the public enemies: therefore,  
*Be it resolved*, That the said Jesse D. Bright is expelled from his seat in the Senate of the United States.

Mr. Wilkinson took the floor to support the resolution, and against the report of the committee. He said: "This is an hour, Mr. President, when men must stand up straight if they would serve their country; it is no time for faltering, for hesitation, or for doubt. And it is my deliberate opinion that, surrounded as we are with treason and with corruption in the high places of this Government, if the Senate fails to discharge its whole duty without any regard to fear or to favor, or without being moved from the right line of duty by personal considerations, this country will be lost. I believe that the firm, steady, and heroic action of Congress must save this nation, if it is saved at all; and I further believe that every other department of the Government has utterly failed to meet with sufficient heroism and virtue the demands which the crisis of the country has made upon them. I am overwhelmed with the revelations which are hourly made of the treason and corruption which surround and enter into every department of this Government; and strange as it may appear, starting as may be the announcement, there is scarcely a single act of treason or of fraud which surrounds, or is in any wise connected with this Government, but that finds an eager and ready apologist in Congress. If this course is not checked at once, then indeed may we bid farewell to all hope of saving the country and the institutions of freedom which our Constitution has guaranteed to the people."

He then considered the points of the case: that the Senator from Indiana did not deny that he wrote the letter,—the manner of its address,—the state of the country at the time when it was written,—the object of the letter,—the position of the writer, &c., and concluded thus: "Mr. President, whilst I regard the letter of the 1st of March last, recommending an inventor of improved firearms to the especial notice of the leader of this wicked war, as giving the clearest and most perfect evidence of disloyalty in him who wrote it, still I think that the letter of the 7th of September last is still more objectionable than the other. At this last date, the war in defence of the Government had assumed the most gigantic proportions; five hundred thousand loyal men were then in the field in defence of our Government, to save it from being destroyed by the attacks of the most ruthless enemy that

ever blackened or disgraced the annals of civilized warfare. The whole nation was reeling to and fro, and staggering like a drunken man; commerce was destroyed; the ordinary business of the entire country had been suspended, and the good men and the loyal men and the true men all over the land thought of nothing, did nothing, cared for nothing but the success of our army and the maintenance of this Government. It was at this time that a Senator of the United States, bound by the most solemn of earthly obligations to sustain the Government in which he held an office of high dignity and honor, boldly declared to the country that he was opposed to the entire policy of the Government—that policy which is for maintaining its very existence!”

Mr. Bayard, of Delaware, replied: “Mr. President, I am not surprised at anything that occurs in times of high excitement; nor am I surprised at distortions of the human intellect by which the most ordinary actions or the simplest forms of expression are perverted from their purpose, and have attached to them a meaning (from emphasis and an imperfect statement of facts) which otherwise no rational man would attach to them. I had hoped, however, that when the resolution of the Senator from Minnesota was submitted to a committee of this body; when the whole matter was investigated and weighed by them, and the party accused heard, and they reported that the resolution ought not to pass, the honorable Senator would be content to submit to the determination of the committee, and without coming here with a written set speech for the purpose of aggression upon my friend from Indiana, would let the vote of the Senate be taken, if he desired it, without the necessity of any controversy on the subject.”

A very extended debate followed, during which Mr. Bright said: “I have said repeatedly that I have no recollection of ever having written this letter. I have no doubt when the letter was asked for, Mr. Lincoln said he wanted to go there to dispose of an invention in firearms. I understand Mr. Lincoln says I gave him a letter to Mr. Floyd in the month of December, which was some time before I gave him the letter to Mr. Davis, recommending his improvement in firearms, whatever it was: I really do not know what it was, and never heard what it was. I went this morning to the War Department, and with the aid of the chief clerk searched its files for the purpose of ascertaining whether there was such a letter there. The chief clerk stated that if it was merely a letter of introduction, such a one as would be given in a case of that kind, the presumption was that Governor Floyd threw it in his basket, and so it had been destroyed, or he might have it among his private papers. Mr. Lincoln, I understand, says I gave him a letter first recommending his firearm to Mr. Floyd. If it was such a valuable improvement, and was likely to be so serviceable in the de-

struction of human life, and I was in collusion with the Southern States, I would hardly have recommended it first to Governor Floyd, then Secretary of War. I suppose I gave him a letter first to Mr. Floyd, and he, finding that like many of these Yankee inventions there was nothing in it, threw it overboard, and then Mr. Lincoln came and bored me for a second letter to Jefferson Davis, and I gave him that one. I have no doubt those are the facts.”

At the close of the debate the vote on the question of expulsion was taken and resulted as follows:

YEAS.—Messrs. Anthony, Browning, Chandler, Clark, Collamer, Davis, Dixon, Doolittle, Fessenden, Foot, Foster, Grimes, Hale, Harlan, Henderson, Howard, Howe, Johnson, King, Lane of Indiana, McDougall, Morrill, Pomeroy, Sherman, Simmons, Sumner, Trumbull, Wade, Wilkinson, Wilmot, Wilson of Massachusetts, and Wilson of Missouri—32.

NAYS.—Messrs. Bayard, Carlile, Cowan, Harris, Kennedy, Latham, Nesmith, Pearce, Powell, Rice, Saulsbury, Ten Eyck, Thomson, and Willey—14.

Mr. Lovejoy, of Illinois, offered a bill for the prohibition of slavery in the Territories of the United States, on which an extended debate took place. He subsequently proposed to modify the substitute as follows, which was agreed to:

To the end that freedom may be and remain forever the fundamental law of the land in all places whatsoever, so far as it lies within the powers or depends upon the action of the Government of the United States to make it so: therefore,

*Be it enacted by the Senate and House of Representatives of the United States of America in Congress assembled, That slavery or involuntary servitude, in all cases whatsoever (other than in the punishment of crime, whereof the party shall have been duly convicted), shall henceforth cease, and be prohibited forever in all the Territories of the United States, now existing, or hereafter to be formed or acquired in any way.*

Mr. Lovejoy then moved to amend by striking out the preamble.

Mr. Cox, of Ohio, said: “I would like to amend that by inserting the words ‘to carry out the Chicago platform, and to dissolve the Union.’ That is the idea.”

The previous question was seconded, and the main question ordered, which was on the amendment striking out the preamble.

The amendment was agreed to.

The bill was subsequently passed—ayes, 85; noes, 50—in the following words: “That from and after the passage of this act there shall be neither slavery nor involuntary servitude in any of the Territories of the United States now existing, or which may at any time hereafter be formed or acquired by the United States, otherwise than in the punishment of crimes whereof the party shall have been duly convicted.”

Thus, what was originally known as the “Wilmot Proviso” offered in the House about 1847, after fifteen years became a law. This was the arrow that had pierced the heart of the Union.

In the Senate, on the 18th of March, the bill

"for the release of certain persons held to service or labor in the district of Columbia" was taken up.

Mr. Davis, of Kentucky, offered the following amendment:

*And be it further enacted,* That all persons liberated under this act shall be colonized out of the limits of the United States; and the sum of \$100,000, out of any money in the Treasury not otherwise appropriated, shall be expended, under the direction of the President of the United States, for that purpose.

Mr. Davis, in support of his amendment, said: "Mr. President, whenever any power, constitutional or unconstitutional, assumes the responsibility of liberating slaves where slaves are numerous, it establishes as inexorably as fate a conflict between the races, that will result in the exile or the extermination of the one race or the other. I know it. We have now about two hundred and twenty-five thousand slaves in Kentucky. Think you, sir, that we should ever submit to have those slaves manumitted and left among us? No, sir; no, never; nor will any white people in the United States of America where the slaves are numerous. If by unconstitutional legislation you should, by laws which you shrink from submitting to the test of constitutionality in your courts of justice, liberate them, without the intervention of the courts, the moment you reorganize the white inhabitants of those States as States of the Union, they would reduce those slaves again to a state of slavery, or they would expel them and drive them upon you, or south of you, or they would hunt them like beasts and exterminate them. They would not do this from choice, but they would do it from necessity. It will produce such a conflict between the races as will render it inevitable, and there will be no escape from it.

"I maintain that it is a matter of humanity to the negro in this city, and of justice to the white population in this city, that when you turn three or four thousand negroes who are now in a state of slavery, free, you should relieve them from the curse of such a population, from its expense, from its burdens upon this community in every form; you ought to assume the philanthropy and the justice—the philanthropy to the negro race and the justice to the white race—to remove these people from the District. You may refuse to do it. If you do, a few years' experience will tell you what a mistake you made."

Mr. Hale, of New Hampshire, replied to the objection of the Senator from Kentucky in regard to the consequences that might ensue from the passage of the bill. He said: "I may remark that of all the forms scepticism ever assumed, the most insidious, the most dangerous, and the most fatal is that which suggests that it is unsafe to perform plain and simple duty for fear that disastrous consequences may result therefrom.

"This question of emancipation, wherever it has been raised in this country, so far as I

know, has rarely ever been argued upon the great and fundamental principles of right; the inquiry is never put, certainly in legislative circles, what is right, what is just, what is due to the individuals that are to be affected by the measure, but what are to be the consequences? Men entirely forget to look at the objects that are to be affected by the bill, in view of the inherent rights of their manhood, in view of the great questions of humanity, of Christianity, and of duty; but what are to be the consequences, what is to be its effect upon the price of sugar, tobacco, cotton, and other necessaries and luxuries of life? The honorable Senator from Kentucky looks upon it in that point of view entirely."

The Senator then proceeded to examine the effects of emancipation in the British West Indies and St. Domingo, and concluded this portion of his argument by saying: "Now, sir, I do not question in the slightest degree the very strong convictions which the honorable Senator from Kentucky has upon this question; but I ask him, and I ask every man who hesitates upon it upon the grounds he has suggested, to take the trouble not to read the frothy speeches made upon the floor of the House of Representatives or the Senate during the last ten or twenty years, but to go to the facts as they are portrayed by the impartial pen of history. I ask them to look at the statistics which exist to-day as to the condition of the colored population in those islands in which emancipation has been tried. They will find that no such disastrous consequences have ensued. Sir, the account that was given of the final inauguration of emancipation in the British West Indies in 1838, ought to stand in all time to be read by every man that wishes to inform himself upon this subject as to the character of this much-abused population, and the effects of this much-abused measure."

The constitutional objection to the bill, he thus treated: "Sir, I do not ask that the Government of the United States should trample upon the Constitution in any one of its provisions. I believe that up to a very late period in our history, it was the conceded doctrine of this Republic, by Statesmen north and south, that the constitutional power to legislate upon the subject of slavery in this District existed in Congress. I know that in late years that has been questioned, and even denied. I know that within the last ten or twelve years this nation has been rent upon a new dogma, which denied the constitutional power of Congress to legislate for the Territories; and, while that question was rending the country, while it was tearing political parties in twain, dividing churches, bringing itself home to the hearts and consciences of this people, the Supreme Court of the United States undertook, with their puny efforts, to throw themselves in the way of the great question by the Dred Scott decision, and to say to the surging waves of humanity that, while washing out the stain of

oppression from our history, they should go thus far and no farther. The Supreme Court will find out ere long how much that has effected. Whether it has done more to wipe out the controversies that they wanted to crush out, or to obliterate whatever of respect there was remaining in the public heart for themselves, they will find out before the issue is settled.

"But, sir, while by this decision the Territories of the United States were taken theoretically from the management of the Federal Government, I believe, though I never read the Dred Scott decision in reference to that particular view of it, it did not go to the extent of saying that Congress had no constitutional power to legislate in the District of Columbia. But, sir, that is left to us. Over this little spot of ten miles square, or what there is left of it after the retrocession of the part ceded by Virginia, we have confessedly the right of legislation; and here in our midst, and by our laws, the system of human slavery exists, and we are called upon to-day to abolish it, to repeal the laws upon which it rests, and to the most limited extent to try what will be the effect of emancipation upon the few slaves that are in this District."

Mr. Doolittle, of Wisconsin, followed in support of the bill. He moved to amend the amendment, so as to make it read:

*And be it further enacted,* That the sum of \$100,000, out of any money in the Treasury not otherwise appropriated, shall be expended under the direction of the President of the United States to aid in the colonization and settlement of such free people of African descent now residing in said District as may desire to emigrate to the republics of Hayti or Liberia, or such other country beyond the limits of the United States as the President may determine.

He said: "The negro question involves more than the question of voluntary or involuntary servitude. I am not satisfied without an answer to the whole question. Jefferson gives it in these words:

Nothing is more certainly written in the book of fate than that these people are to be free; nor is it less certain that the two races, equally free, cannot live in the same Government. Nature, habit, and opinion have drawn indelible lines of distinction between them. It is still in our power to direct the process of emancipation and deportation peaceably, and in such slow degree as that the evil will wear off insensibly, and their places be, *pari passu*, filled up with free white laborers. If, on the contrary, it is left to force itself on, human nature must shudder at the prospects held up.

"Mr. President, in the temperate zone, the Caucasian race has always been dominant, and always will be. In the torrid zone the colored man dominates, and will forever. No laws of Congress or any other legislative power can reverse this great law stamped upon the earth and upon the constitution of man. Poets may dream otherwise; unwise philanthropy may hope to make it otherwise; but it cannot be done. The Creator has written it upon the earth and upon the race."

Mr. Doolittle then examined the condition of the West India Islands—the relations of the

white and black races—the solution of the negro question, and said: "Mr. President, while I would connect the action of this Government in emancipating the slaves in this District with the idea of colonization, I would make it, not compulsory, but voluntary emigration. I would embrace those only who by their own free consent are willing to go from this District to Hayti, Liberia, or elsewhere. I am not in favor of the amendment as proposed by the Senator from Kentucky (Mr. Davis), to compel the colonization of all who may be set free under this bill. Upon this point I desire not to be misunderstood. I would make this colonization voluntary; upon their own free consent. I would hold out inducements which might lead them to go, and not compel them by force of arms. For that purpose I have offered my amendment."

Mr. Willey, of Virginia, followed in opposition to the bill, saying: "Mr. President, the question which I wish to discuss is: Is it wise or expedient, under existing circumstances, and at this time, to pass this bill? Sir, this bill is a part of a series of measures, already initiated, all looking to the same ultimate result—the universal abolition of slavery by Congress. This bill and the bill of the Senator from Illinois (Mr. Trumbull), for the confiscation of property in the seceded States, and the resolutions introduced by the Senator from Massachusetts (Mr. Sumner) some weeks ago, contemplate the same purpose—unconditional, immediate, and universal emancipation. It is to the consequences which must inevitably result from these measures, if adopted, to which I solicit the attention of the Senate. These consequences, in my judgment, involve the lives of thousands of my fellow citizens, and the happiness of all the loyal people of all the border slaveholding States. Perhaps I should be justified in saying that they involved in most serious peril the restoration of the Union and the Constitution.

"Sir, the agitation of these questions under existing circumstances, must be positively mischievous. Will it not create strife and divisions here? Will it not disturb the country? Above all, will it not afford aid and comfort to the enemy? I am sure it will. It will be used by the leaders of the rebellion to 'fire the Southern heart.' The people of the South have been taught to believe that the object and design of the Republican party was to abolish slavery in all the States. These propositions will be seized upon as evidence of this intention. They will say, 'Look at their unconstitutional confiscation laws, making no safe or practical discrimination between Union men and secessionists. Look at the bill to abolish slavery in the District of Columbia; it is a stepping stone to further encroachments.' Especially will they point to the sweeping resolutions of the great apostle of abolition, the Senator from Massachusetts (Mr. Sumner), which, by one dash of the pen, deprives every Southern man

of his slaves. This is what the rebel leaders will delight to say, and delight to have so much reason to say."

The amendments were rejected, and the original bill then considered.

Mr. Davis, of Kentucky, in opposition to the bill said: "I shall now assume the position that the Congress of the United States have no power to emancipate a slave anywhere in a State or in the District of Columbia. The great rights which are secured by the Constitution to the citizen and to the States, and the great restrictions upon the powers of Congress by the Constitution also limit and restrict the grant of legislative power to Congress in the District of Columbia. That is my proposition. It is one founded in the Constitution itself. It is immovably moored in that instrument, and no lawyer can tear it from its firm anchorage. It is upon that position that I now propose to draw my deduction, and it is this: I say that all the great rights secured by the Constitution to the citizen exist in the District of Columbia as they exist in all the States of the Union, notwithstanding the clause in the Constitution which gives Congress the exclusive power of legislation in the District. That exclusive power means necessarily in subordination to and within all the prohibitions and the rights made and secured by the Constitution itself. What is one of those rights secured universally in this District as well as in the States? It is the right of property. Is not the right to the writ of *habeas corpus*, the right to trial by jury, the right to freedom of conscience, the freedom of speech, and the liberty of the press guaranteed to the people of the District of Columbia as inalienably, as inviolably, as inextricably, as they are guaranteed to the citizens of any of the States? I say they are; and I say among other rights that are guaranteed to the people of the District of Columbia, and to every citizen of the United States, is the right of property. He cannot be deprived of his property except in the mode prescribed and authorized by the Constitution of the United States. I will now read that clause in the amendments to the Constitution:

No person shall be held to answer for a capital or otherwise infamous crime, unless on a presentment or indictment of a grand jury, except in cases arising in the land or naval forces, or in the militia, when in actual service in time of war or public danger; nor shall any person be subject for the same offence to be twice put in jeopardy of life or limb; nor shall be compelled in any criminal case to be a witness against himself, nor be deprived of life, liberty, or property without due process of law; nor shall private property be taken for public use without just compensation.

"I concede that whenever it is necessary, in the administration of the Government, in carrying forward the great business of the Government of the United States, that the Government should have private property for public use, it has the right to take that private property on the condition of making compensation for it, and upon no other condition. The point

in that provision of the Constitution is this, and I ask the attention of my honorable friend from Maine to it: the Government of the United States cannot take the citizen's property capriciously; it cannot take it without a purpose, even by making just compensation for it; it cannot take it to burn it, if it may be consumed, or to destroy it; it may take it for public use. This is the simple and sole condition upon which the inviolability of private property can be broken by the Government itself; it must be necessary for public use. What is use? It is employment. To use is to employ. To employ is to apply as an instrument or an agent the thing that is taken for public use; and unless in good faith and in strict truth the thing or the property is taken for public use in the sense in which I have stated it, there is no constitutional right on the part of the Government to take the property at all.

"Even if Congress had the power to emancipate slaves, I ask if that is not taking from the owners of those slaves their private property? How is that private property to be taken from them? The Constitution provides that no citizen shall be compelled in any criminal case to be a witness against himself.

Nor be deprived of life, liberty, or property, without due process of law; nor shall private property be taken for public use without just compensation.

"This is my position: that the Congress of the United States has not the right to declare arbitrarily a mode, and arbitrarily a limit of price, even if it has the power to emancipate slaves in this District, by which these slaves will be taken from their owners and manumitted. If the slaves are taken for the purpose of being emancipated, of being liberated, they must be taken by due process of law. What is that due process of law? It is this: just as a citizen's property of any other class or description is taken from him for any purpose of the Government, so is the negro to be taken from his owner, even conceding that Congress has the power to liberate him. You must take that slave and you must have him appraised judicially, and by a mode that is quasi judicial; you must have a court to act in the matter; you must have a court to summon a jury; you must have a court to appoint commissioners, and under the supervision and sanction of this court, this matter of valuing the property in slaves is to proceed, as it does in relation to any other property of a citizen that may be taken by the exercise of the power of Congress or of the General Government over him."

Mr. Davis then alluded to the statements of the Administration relative to the objects of the war, and read the following extract from the resolution passed at the preceding session in July, 1861:

That this war is not prosecuted upon our part in any spirit of oppression, nor for any purpose of conquest or subjugation, nor for the purpose of overthrowing or interfering with the rights or established institutions

of those States; but to defend and maintain the supremacy of the Constitution and all laws made in pursuance thereof, and to preserve the Union, with all the dignity, equality, and rights of the several States unimpaired; that as soon as these objects are accomplished the war ought to cease.

"Now, sir, here is my position: if you intended to make and did make that pledge in good faith, you have no right now to enlarge the purposes of the war."

Mr. Clark: "Does the Senator understand this to be a purpose of war that we are now about?"

Mr. Davis: "Yes, sir; this is a purpose of war now. It is an entering wedge. You want to get the head in, and then you intend to push the monster through. That is what you are after. If there was to be no other movement upon slavery, we never should have heard of this bill to abolish slavery in the District of Columbia. It is extreme men that bring parties and nations to ruin. Men in a body will violate pledges that they would never dream of violating as single individuals. Here are your pledges, as strong and as emphatic as they can be made, defining the purpose for which you intended to wage the war. I say that you cannot with a due regard to your pledged word, to your faith, to your honor as men and as patriots, enlarge materially the purposes of the war. The object of such enlargement is not to limit and to spend the force of your action upon this downtrodden and oppressed District, but it is to extend your usurpations into the States. This is but a preliminary operation. You are endeavoring to experiment now how far you can go, and how far the moderate men of your party will go with you."

Mr. Wilson, after stating the position of the slave in the District and the laws regulating his conduct, said: "Have not the American people the constitutional right to relieve themselves from the guilt and shame of upholding slavery in their national capital? Would not the exercise of that right be sanctioned by justice, humanity, and religion? Does the Senator suppose that we, the representatives of American freemen, will cowardly shrink from the performance of the duties of the hour before these dogmatic avowals of what the men and the women of the slaveholding States will do? Sir, I tell the Senator from Kentucky that the day has passed by in the Senate of the United States for intimidation, threat, or menace, from the champions of slavery."

Mr. Kennedy, of Maryland, followed in opposition to the bill. He said: "I shall content myself with the simple purpose, in a very few words, of entering the most solemn protest, in the name of my State, against the adoption of this measure which I have ever yet made as one of the representatives of her sovereignty on this floor. The State of Maryland is most deeply interested in the result of this unhappy and unnatural war. All of her prosperity, present and to come; all of her historical renown in the past, connected with her bloody

struggles for this Union; all of her dignity as a State, is involved in the policy by which this contest is to be conducted and finally settled.

"I earnestly hope I may be mistaken in the purposes and power of the majority to pass this measure; but if otherwise, then, sir, it no longer remains to her, either by argument or protest, to obtain her rights as a sovereign State, or just consideration for her dignity or interests as an equal in this Union under the Constitution. To show that the faith of this Government has long been pledged to the States of Maryland and Virginia not to interfere with slavery in this District, I will take the liberty of presenting to the Senate the views of an able committee of the House of Representatives presented in 1836, a committee composed of distinguished gentlemen from every section of the country."

From this report he read the following and other extracts:

Your committee must go further, and express their full conviction that any interference by Congress with the private interests or rights of the citizens of this District, without their consent, would be a breach of the faith reposed in the Federal Government by the States that made the cession, and as violent an infraction of private rights as it would have been if those States themselves, supposing their jurisdiction had remained unimpaired over their territory, had abolished slavery within those portions of their respective limits, and had continued its existence upon its present basis in every other portion of them. And surely there is no citizen in any quarter of the country, who has the smallest regard for our laws and institutions, State and national, or for equal justice, and an equality of rights and privileges among citizens entitled to it, who would attempt to justify such an outrage on the part of those States. The question then is, are the citizens of the District desirous of a change themselves? Has any request or movement been made by them that would justify an interference with their private rights on the part of Congress? None, whatever!

He also said: "In further support of these views, I beg to refer to the resolutions of Mr. Clay, which were adopted by the Senate in 1838:

*Resolved*, That when the District of Columbia was ceded by the States of Virginia and Maryland to the United States, domestic slavery existed in both of those States, including the ceded territory, and that, as it still continues in both of them, it could not be abolished within the District without a violation of that good faith which was implied in the cession, and in the acceptance of the territory, nor, unless compensation were made to the proprietors of slaves, without a manifest infringement of an amendment to the Constitution of the United States, nor without exciting a degree of just alarm and apprehension in the States recognizing slavery, far transcending in mischievous tendency any possible benefit which could be accomplished by the abolition.

*Resolved, therefore*, That it is the deliberate judgment of the Senate, that the institution of domestic slavery ought not to be abolished within the District of Columbia; and it earnestly hopes that all sincere friends of the Union and of harmony and general tranquillity, will cease to agitate this disturbing question.

Mr. Saulsbury, of Delaware, offered the following amendment:

*And be it further enacted*, That the said persons liberated under this act shall, within thirty days after the passage of the same, be removed at the expense of the Federal Government into the States of Maine, New

Hampshire, Massachusetts, Rhode Island, Connecticut, Vermont, New York, Pennsylvania, New Jersey, Ohio, Indiana, Illinois, Michigan, Iowa, Wisconsin, Minnesota, Kansas, Oregon, and California, and that said persons shall be distributed to and among the said States *pro rata* according to the population of the same.

He said: "While I speak in support of that amendment, I will simply say, to be frank with the Senate, that I intend to vote against the bill in any shape in which it can be presented. I offer this amendment, however, upon the principle adopted by the Senator from Kentucky (Mr. Davis) yesterday, of perfecting the bill, as far as I can, before the final vote; and I do think that if gentlemen who are not interested in this question will persist in freeing the slaves in this District or elsewhere, they ought to be willing to take them among themselves; and they ought not to throw this class of persons, idle and vicious and worthless, as we know they will be, upon this District, which already, I am told, has a population of eleven thousand free negroes. If they should persist in setting the additional number of three thousand free, the nineteen Free States ought certainly, having so few among themselves, to be willing to share the burden with the people of this District, by dividing the freed slaves among themselves, still leaving this District with the burden of eleven thousand free persons of color. It would be one of the most sublime examples of philanthropy I have ever seen. By your fruits you shall be known. If it is a spirit of philanthropy and a love of freedom that prompts you, gentlemen, to set these three thousand slaves in the District of Columbia free; render that philanthropy and that love of freedom sublime in the sight of all human kind, by taking into your own embrace, in your own midst, the slaves thus liberated. Prove that you are sincere."

Mr. Wilkinson, of Minnesota, advocated the passage of the bill, saying: "Believing, as I do, that human slavery is the great sin of this country, that it is in violation of every principle of justice and of truth, that its influence upon this country, and upon the world, has a tendency alike to encourage everything that is evil, and to repress everything that is good in the State; that its evil influences are visited alike upon the master and the slave; that it affects us for evil in our political as well as in our social relations, and that it is the primary cause of the wicked rebellion which has risen up against the constitutional authorities of the Government, I feel bound, by every vote which I am called upon to give, and by every word which I may utter upon this question, to do everything in my power toward its final extinction; and, so far as my influence goes, to blot out the last remains of slavery upon this continent.

"Thus believing, I cannot place expediency in the scales against justice, nor shall I fail to perform a simple duty for fear of the consequences which may result from such action."

Mr. Sumner, of Massachusetts, next took the

floor, saying: "It is surely enough for the present to consider slavery at the national capital; and here we are met by two inquiries so frankly addressed to the Senate by the clear-headed Senator from Kansas (Mr. Pomeroy): first, has slavery any constitutional existence at the national capital? and, secondly, shall money be paid to secure its abolition? The answer to these two inquiries will make our duty clear. If slavery has no constitutional existence here, then more than ever is Congress bound to interfere, even with money; for the scandal must be peremptorily stopped, without any postponement or any consultation of the people on a point which is not within their power.

"It may be said that, whether slavery be constitutional or not, nevertheless it exists, and therefore this inquiry is superfluous. True, it exists as a monstrous fact; but it is none the less important to consider its origin, that we may understand how, assuming the form of law, it was able to shelter itself beneath the protecting shield of the Constitution. And when we shall see clearly that it is without any such just protection, that the law which declares it is baseless, and that in all its pretensions it is essentially and utterly brutal and unnatural, we shall have less consideration for the slave tyranny, which, in satisfied pride, has thus far—not without compunction at different moments—ruled the national capital, reducing all things here—public opinion, social life, and even the administration of justice—to its own degraded standard, so as to fulfil the curious words of an old English poet:

It serves, yet reignes as King;  
It lives, yet's death: it pleases full of paine.  
Monster! ah, who, who can thy being faine?  
Thou shapelasse shape, live death, paine pleasing, servile reigns.

"It is true, there can be no such thing as property in man; and here I begin to answer the questions propounded by the Senator from Kentucky (Mr. Davis). If this pretension is recognized anywhere, it is only another instance of the influence of custom, which is so powerful as to render the idolater insensible to the wickedness of idolatry, and the cannibal insensible to the brutality of cannibalism. To argue against such a pretension seems to be vain; for the pretension exists in open defiance of reason as well as of humanity. It will not yield to argument; nor will it yield to persuasion. It must be encountered by authority. It was not the planters in the British islands or in the French islands who organized emancipation, but the distant Governments across the sea, far removed from the local prejudices, who at last forbade the outrage. Had these planters been left to themselves, they would have clung to this pretension as men among us still cling to it. Of course, in making this declaration against the idea of property in man, I say nothing new. An honored predecessor of the Senator from Maryland (Mr. Kennedy), whose fame as a statesman was eclipsed, perhaps, by



his more remarkable fame as a lawyer—I mean William Pinkney, and it is among the recollections of my youth that I heard Chief Justice Marshall call him the undoubted head of the American bar—in a speech before the Maryland House of Delegates, spoke as statesman and lawyer when he said :

Sir, by the eternal principles of natural justice no master in the State has a right to hold his slaves in bondage for a single hour.

“And Henry Brougham spoke not only as statesman and lawyer, but as orator also, when, in the British Parliament, he uttered these memorable words :

Tell me not of rights—talk not of the property of the planter in his slaves. I deny the right—I acknowledge not the property. The principles, the feelings of our common nature, rise in rebellion against it. Be the appeal made to the understanding or to the heart, the sentence is the same that rejects it. In vain you tell me of laws that sanction such a claim. There is a law above all the enactments of human codes—the same throughout the world, the same in all times: it is the law written by the finger of God on the heart of man; and by that law, unchangeable and eternal, while men despise fraud and loathe rapine and abhor blood they will reject with indignation the wild and guilty phantasy that man can hold property in man.

“Slavery exists at the national capital absolutely without support of any kind in the Constitution; and here again I answer the Senator from Kentucky (Mr. Davis). Nor is this all. Situated within the exclusive jurisdiction of the Constitution, where State rights cannot prevail, it exists in open defiance of most cherished principles. Let the Constitution be rightly interpreted by a just tribunal, and slavery must cease here at once. The decision of a court would be as potent as an act of Congress.”

Mr. Sumner then proceeded to consider “how completely slavery had installed itself here (in this District) in utter disregard of the Constitution, and compelled Congress ignobly to do its bidding.”

A historical statement was made of the proceedings which led to the location of the capital, in illustration of this position, and he concluded this portion of his remarks by saying: “Bringing the argument together, the conclusion may be briefly stated. The five-headed barbarism of slavery, beginning in violence, can have no legal or constitutional existence, unless through positive words expressly authorizing it. As no such positive words can be found in the Constitution, all legislation by Congress supporting slavery must be unconstitutional and void, while it is made still further impossible by positive words of prohibition guarding the liberty of every person within the exclusive jurisdiction of Congress.”

Advocating the appropriation of money for compensation to the owners, he said, in conclusion: “Amidst all present solicitudes, the future cannot be doubtful. At the national capital slavery will give way to freedom; but the good work will not stop here. It must proceed. What God and nature decree rebellion cannot arrest. And as the whole, wide-

spread tyranny begins to tumble, then, above the din of battle, sounding from the sea and echoing along the land, above even the exultations of victory on well-fought fields, will ascend voices of gladness and benediction, swelling from generous hearts wherever civilization bears sway, to commemorate a sacred triumph, whose trophies, instead of tattered banners, will be ransomed slaves.”

Mr. Davis, of Kentucky, followed and examined the entire constitutional question relative to the bill. As his remarks present the views and principles upon which the Government has been hitherto administered, they afford a criterion by which every one may judge of the extent of the great political change which the country and government are now undergoing.

“Mr. President, I will say a few words upon the subject of the power which Congress claims to exercise over this question. It seems to me that the reason why this power has been so uniformly and so generally conceded is that the question of power has never been carefully examined. I laid down a few days ago this proposition—and I defy the Senator from Maine or the Senator from New Hampshire to refute it—that there is no positive written law which establishes property in a slave or in land or in a horse or in any other subject of property; that the law upon that subject arises from the uniform custom and usage of the civilized world. And I laid down this further proposition; that my legal right to my slave was precisely of the same nature and character with my legal right to my land; and that if I were a citizen of the District of Columbia, Congress would have no more right to deprive me of the one subject of property than of the other.

“Both the gentlemen deny that property can exist in a human being. That is their broad proposition. Upon that point I am totally at issue with them, and I am sustained by the Constitution of the United States, and by the judgment of the Supreme Court and of all the circuit judges of the United States wherever the question has been mooted and decided. The Senator from New Hampshire now concedes explicitly that Congress has no power to take from the people of the District their houses or their lands, or any other property but their slaves, as I understand him. I ask the gentleman for the law or the provision of the Constitution which forms the interdict, and he explicitly gives it to me. It is the provision that no citizen's property shall be taken for public use except by due process of law and upon just compensation. I maintain that that prohibition on the power of Congress applies as legitimately and with as much truth and logic to slaves as it does to real estate.

“My proposition a few days ago was that slavery was general, that the abolition of slavery was local; and that proposition I sustained by reading from the opinion of Chief Justice Marshall in the case of the Antelope, and he

sustained the opinion which he rendered in that case by quoting from the decrees of Lord Stowell, of the admiralty court of England, who was a greater judge than ever Chief Justice Mansfield was. They both decide this principle broadly and without any sort of reservation or condition, that slavery and the slave trade existed by public national law."

Mr. Collamer: "The gentleman will permit me to say that I take issue with him on that point. It is acknowledged by international law only in such nations as recognize it."

Mr. Davis: "No, sir; my honorable friend is mistaken there, and I will tell him wherein, in my judgment, he is mistaken. The Supreme Court of the United States, in this decision rendered by Chief Justice Marshall, decided that slavery and the slave trade existed by national law, and that this national law may be repealed locally by the proper legislation of every country upon the earth; and that this national law, recognizing slavery and the slave trade, exists in every country save in those countries where, by positive enactment, it has been repealed."

Mr. Collamer: "That, to my mind, amounts to precisely the same proposition that I stated."

Mr. Davis: "No, sir. I will read from the opinion in the case of the Antelope again, and I will read from several other opinions. I know that gentlemen are becoming impatient for the sacrifice; but here, sir, I stand up in my place in the Senate Chamber of the United States, and I maintain the rights of a people who have no self-government, and who have no representation in this chamber; and although gentlemen may be restive under the exercise of this right of mine, which I claim, to appear here in defence of the rights of property of the people of this District, they will have to submit to that restiveness. In the case of the Antelope (10 Wheaton's Reports, 120), the court say:

The question whether the slave trade is prohibited by the laws of nations has been seriously propounded, and both the affirmative and negative of the proposition have been maintained with equal earnestness.

That it is contrary to the law of nature, will scarcely be denied.

"I never denied it myself; but I say that the law created by the usages of mankind overrules the law of nature in relation to this subject. What is the law of nature? My honorable friend from Vermont might have one code of the law of nature, and other gentlemen might have other codes of the law of nature. When this traffic was indulged in by the civilized world, and the States of Massachusetts and Rhode Island were inundating the colonies with slaves torn from Africa, and selling them for a price, what was the law of nature then in Massachusetts that indulged such a traffic; and what was the law of nature then in the civilized world? What is the law of nature now in Turkey and in China? What was the law of nature in Europe two centuries ago? What is

the law of nature in Utah? The law of nature varies with the altered condition of civilization and the condition of the world; and what is the law of nature in one age and in one country and in one generation, is not the law of nature universally. It is because of this want of uniformity in the law of nature, and because there is no common tribunal to ascertain and define and establish what the law of nature is, that it has been uniformly decreed to be subservient to the positive laws of any country, and to the laws of nations, as established upon the usages of the civilized world. But I will read:

That it is contrary to the law of nature will scarcely be denied. That every man has a natural right to the fruits of his own labor, is generally admitted; and that no other person can rightfully deprive him of those fruits, and appropriate them against his will, seems to be the necessary result of this admission. But from the earliest times war has existed, and war confers rights in which all have acquiesced. Among the most enlightened nations of antiquity, one of these was, that the victor might enslave the vanquished.

"That was once a principle of the law of nations as recognized by the whole world. I admit that that principle has been exploded, and properly exploded, by the Christian civilization of this age.

This, which was the usage of all, could not be pronounced repugnant to the law of nations, which is certainly to be tried by the test of general usage. That which has received the assent of all, must be the law of all.

Slavery, then, has its origin in force; but as the world has agreed that it is a legitimate result of force, the state of things which is thus produced by general consent, cannot be pronounced unlawful.

"What does Chief Justice Marshall here decide? That although slavery has its origin in force and is against the law of nature, yet as it has been universally recognized by the civilized world, it exists and is acknowledged by the laws of nations.

Throughout Christendom this harsh rule has been exploded, and war is no longer considered as giving a right to enslave captives. But this triumph of humanity has not been universal. The parties to the modern law of nations do not propagate their principles by force; and Africa has not yet adopted them. Throughout the whole extent of that immense continent, so far as we know its history, it is still the law of nations that prisoners are slaves. Can those who have themselves renounced this law, be permitted to participate in its effects by purchasing the beings who are its victims?

"Here is a principle to which the honorable Senator from Maine referred:

Whatever might be the answer of a moralist to this question, a jurist must search for its legal solution in those principles of action which are sanctioned by the usages, the national acts, and the general assent of that portion of the world of which he considers himself as a part, and to whose law the appeal is made. If we resort to this standard as the test of international law, the question, as has already been observed, is decided in favor of the legality of the trade. Both Europe and America embarked in it; and for nearly two centuries it was carried on without opposition and without censure. A jurist could not say that a practice thus supported was illegal, and that those engaged in it might be punished either personally or by deprivation of property.

"Now, I ask the attention of the Senator from Vermont to this point in the decision :

In this commerce, thus sanctioned by universal assent, every nation had an equal right to engage. How is this right to be lost? Each may renounce it for its own people; but can this renunciation affect others? No principle of general law is more universally acknowledged than the perfect equality of nations. Russia and Geneva have equal rights. It results from this equality that no one can rightfully impose a rule on another. Each legislates for itself, but its legislation can operate on itself alone. A right, then, which is vested in all by the consent of all, can be divested only by consent; and this trade, in which all have participated, must remain lawful to those who cannot be induced to relinquish it. As no nation can prescribe a rule for others, none can make a law of nations; and this traffic remains lawful to those whose Governments have not forbidden it.—10 *Wheaton*, pp. 120-122.

"There is the principle."

Mr. Collamer: "The gentleman has a peculiar way of reading that decision."

Mr. Davis: "I read it according to the letter."

Mr. Collamer: "Gentlemen who are tenacious about that particular form of reading, are utterly incapable of being answered to their satisfaction. I cannot, by any version I can give it, satisfy the gentleman; but every lawyer who reads that case and other cases cognate to the same subject in other books, understands it thus: when a question comes before a court in relation to a prize of a vessel engaged in the slave trade, upon the broad law of nations they cannot declare it a prize if the nation to which the vessel belongs make that business legitimate. That is all there is in that decision. It is that the law of nations recognizes slavery as existing and lawful in those nations that make it so; and that is all."

Mr. Davis: "There is a little more, Mr. President, notwithstanding the gentleman's position. It decides that the slave trade was once practised by all the civilized nations of the world, and it decides, furthermore, that it cannot be restricted except by positive legislation of the countries that choose to restrict it."

Mr. Collamer: "Will the gentleman permit me one moment on that point? When it was universal, it was because it was made so by the acts of the several nations themselves. It was not a law of nations; it was the law of each nation, and therefore of all; but it was a law for each nation that made it, not an international law; and the very fact that some nations may repeal that law, and prevent its being operative on them, while others may retain it and have it operative on them, shows that it is not a part of the law of nations, for that law cannot be changed in that way. Another thing: it never was a law of nature. The laws of nature can never change, until nature and nature's God change."

Mr. Davis: "The gentleman is still mistaken. I admit that the law of nations was made by the practice of nations, and that is what this opinion says. I will read an opinion directly that will show it conclusively—an opinion of Judge McLean himself. Neither the Senator

from Vermont nor any other Senator here can find any positive express law of any nation upon the earth sanctioning the slave trade, except the Constitution of the United States, which continued the traffic until the year 1808."

Mr. Collamer: "Allow me to say to the gentleman that on that point I take distinct issue with him. The Constitution never continued the slave trade one day. It merely said that Congress should not interfere with the importation or immigration of such persons as the States might think proper to admit until after a certain time."

Mr. Davis: "The Senator from Vermont has informed me that he cannot convince me. I agree with him in that proposition; and there is another proposition on which there is even less doubt than on that in my mind, and that is that I cannot convince him. Therefore I will proceed with my speech as though my honorable friend was not a hearer at all."

"The Supreme Court of the United States, in the case of the *Antelope*, laid down the doctrine and the principle that the law which regulates the slave trade and establishes it as a legal traffic arises from custom and usage alone, not from positive enactment; and further, that the law of nations recognizing the validity of the slave trade once existed among all the civilized nations of the world. France had colonies in the West India Islands; England had colonies there; so had Spain, Portugal, Denmark, Sweden, Holland; and each one of those nations was engaged in the slave trade. Their usage for two centuries, according to the language of this decision, established the slave trade as a legal traffic. It existed, not by positive law, but by usage and custom conformed to by all the civilized nations of the world; and having that authority and that extent of existence, the only way in which it ceased to exist anywhere in any of the countries of the earth, was by positive local prohibition. I believe that Brazil still continues the trade. By what authority? By the law of nations. So far as any nation has not by its own positive legislation, or by its treaty stipulations, prohibited the slave trade, it still exists in that nation, and with its people and subjects, as a legitimate trade sanctioned by the law of nations. The court say:

No principle of general law is more universally acknowledged than the perfect equality of nations. Russia and Geneva have equal rights. It results from this equality that no one can rightfully impose a rule on another. Each legislates for itself, but its legislation can operate on itself alone. A right, then, which is vested in all by the consent of all, can be divested only by consent; and this trade, in which all have participated, must remain lawful to those who cannot be induced to relinquish it. As no nation can prescribe a rule for others, none can make a law of nations, and this traffic remains lawful to those whose Governments have not forbidden it.

"Suppose the United States Government had never made the slave trade piracy, would it not still exist as a legitimate trade to the people of the United States, in which they might enter?

Most certainly. The Supreme Court have decided this principle again and again. It is true that where a nation, either by its positive enactments or by its treaty stipulations, proscribes the slave trade, it is not lawful for the subjects or people of that State or nation to enter into that trade; but that constitutes the exception. This case just as explicitly and as undeniably establishes the position that if a single nation upon earth stands out, and fails or refuses by its legislation or by its treaty engagements to proscribe the slave trade, the slave trade still exists in relation to that nation as a legitimate traffic. So much for the decision in the case of the Antelope.

"Now, sir, I will read another authority, and it is the authority of the judge dwelt upon with so much pleasure and high approval by the honorable Senator from Massachusetts (Mr. Sumner) the other day—Judge McLean. In the case of *Henry Miller vs. George McQuerry* (5th McLean's Reports, p. 472), he said :

No proof, it is contended, has been offered to show that Kentucky is a State in which slavery is authorized by law. And a discussion in the Senate of the United States is referred to, in which certain Senators declared there was no law in the South expressly establishing slavery. It is with regret that I hear this argument relied on in this case. It was used by gentlemen of the South to justify the introduction of slavery into our Territories without the authority of law. In *Groves vs. Slaughter*, a Mississippi case, reported in 15 Peters's Reports, 450, the Supreme Court of the United States declared that slavery was local, and that it could not exist without the authority of law; that it was a municipal regulation.

"I observe that gentlemen smile at this quotation. Let them wait a moment and they will see that it is explained, and it is shown that the position here quoted is not the true position. Slavery is not a municipal regulation, and the learned judge shows it in this very opinion, as you will see presently. What is a municipal regulation? It is a regulation that is made by local, civil law. Here is the slave trade, not founded, not created, not having its origin or sanction in local law at all, but by the universal custom and usages of the civilized world, as decided in the case of the Antelope, and as this learned judge himself recognizes :

Whether this law was founded upon usage, or express enactment, is of no importance. Usage of long continuance, so long that the memory of man runneth not to the contrary, has the force of law. It arises from long-recognized rights, countervailed by no legislative action.

"That is the whole case. Usage makes national law, usage makes public law; that establishes in what subjects property exists, and establishes what is legitimate trade among the nations of the earth. This opinion so decides, and it decides that when usage has established these principles they cannot be abolished or varied or modified, except by legislative enactment.

It arises from long-recognized rights, countervailed by no legislative action. This is the source of many of the principles of the common law. And this for a century or more may constitute slavery, though it be

opposed as it is to all the principles of the common law of England. I speak of African slavery.

"The same opinion continues :

But such a law can only acquire potency by long usage. Now, it may be admitted that in some of the Southern States, perhaps in all of them, there cannot be found a statute which contains the words : "And be it enacted, that slavery shall exist."

"That is a historical and a legal fact. So far as I know or have read—and I admit that my reading has been very limited compared with that of the learned gentleman from Massachusetts—there is not a positive written law in any of the States of Europe that ever indulged in this traffic, sanctioning and legalizing it. That law which most directly comes up to the point of establishing the slave trade is found in the Constitution of the United States which permitted its continuance until 1808, and that at the instance of Massachusetts and other Northern States. They were sustained in that action by Georgia, South Carolina, and North Carolina; Virginia, Pennsylvania, and New Jersey went for the immediate abolition of the slave trade, and it would have been abolished at the time of the adoption of the Constitution by a provision to take immediate effect, if it had not been for the resistance and the opposition made to it by South Carolina, North Carolina, and Georgia, and Massachusetts and Connecticut and some of the other Northern States. Judge McLean in this decision says :

Now, it may be admitted that, in some of the Southern States, perhaps in all of them, there cannot be found a statute which contains the words : "And be it enacted that slavery shall exist;" and this was what was denied in the Senate. But this does not shake the decision of the Supreme Court above referred to. Usage of great antiquity acquires the force of law. The denial therefore that slavery existed by virtue of an express law, or by statute law, which was intended to be denied, was no denial at all.

"That is what Judge McLean decided. It was a case of this character : a slave had eloped from the State of Kentucky; there were certain citizens of the State of Ohio who gave aid to that slave in making his escape to Canada; they were sued under the law of Congress for giving that aid, and they were held to pay damages for having aided the slave to escape. The counsel for the defence assumed as one of the grounds of defence that there was no positive law, no statute enacted in Kentucky, at least none shown upon the trial, which established slavery. Judge McLean conceded that to be the fact; but instead of that being a denial that the right of property existed in the claimant, he expressly stated in words that it was no denial at all. In the case of *Jones vs. Vanzandt* (2 McLean, 602) the same learned judge said :

In our colonial governments, and under the confederation, no general provision existed for the surrender of slaves. From our earliest history, it appears that slavery existed in all the colonies.

"How did it exist in all the colonies? Not by positive enactment, not by any positive law; it existed only by public, national law, based upon the usage of the civilized world, and the

engaging in the slave trade of the whole civilized world. That is the origin and foundation of the slave trade; that is the origin and foundation of the property of the owner of a slave to that slave; and Judge McLean decided in this case that, for the defence to assume that there was no statute, no positive law giving to the claimant of a slave a right of property in the slave, was no denial whatever of his right of property. In the case I last referred to—*Jones vs. Vanzandt*—Judge McLean said:

From our earliest history it appears that slavery existed in all the colonies; at the adoption of the Federal Constitution it was tolerated in most of the States.

Property, real or personal, takes its designation from the laws of the States. It was not the object of the Federal Government to regulate property. A Federal Government was organized by conferring on it certain delegated powers, and by imposing certain restrictions on the States. Among these restrictions it is provided that no State shall impair the obligation of the contract, nor liberate a person who is held to labor in another State from which he escaped. In this form the Constitution protects contracts and the right of the master, but it originates neither.

“There is a decision in which the right of the master to his slave is expressly recognized, and it is recognized to the form and extent of giving a judgment for a large sum of money against a citizen of Ohio who had aided a slave to make his escape; and yet the honorable Senator from New Hampshire and the honorable Senator from Maine assume that there can be no property in slaves.

“Well, sir, I have got some more law upon that subject. We are all familiar with the provision of the Constitution that authorized the reclamation of fugitive slaves from the States. We are familiar with the provision that establishes the ratio of representation on the basis of three fifths of the slaves, including all the white population and the free population. We are all familiar with the provision that bases direct taxation on the same basis of population. We are all familiar with the provision that continued the slave trade up to 1808. What did Congress do? In 1793 it passed a fugitive slave law to authorize the owners of slaves to reclaim them. That law was decided by the Supreme Court to be constitutional. Now, sir, if property cannot exist in a slave when a slave escaped from the State of Kentucky and went to Ohio, a Free State, what principle of law, or of reason, or of common sense would authorize the courts of the country to render a judgment in favor of the claimant, the owner of that slave, who pursued him into the State, against a man who aided in his escape? In 1850 another and a more efficient fugitive slave law was passed. The constitutionality of the previous fugitive slave law of 1793 came up in the case of *Prigg* against the State of Pennsylvania, in which the opinion of the court was rendered by Justice Story, and the other judges gave their opinions *seriatim*. Every judge of the Supreme Court decided that law to be constitutional. It would be absurd and nonsensi-

cal for the court to decide that a law is constitutional for pursuing a subject of property in a State in which subject the right of property cannot possibly exist! I will read a clause from that decision. The provision of the Constitution is in these words:

No person held to service or labor in one State under the laws thereof, escaping into another, shall, in consequence of any law or regulation therein, be discharged from such service or labor, but shall be delivered up on claim of the party to whom such service or labor may be due.

“I admit that the Legislatures may regulate the property of the owner of a slave in the slave. I admit that the Constitution treats slaves as persons as well as property; that it is murder, in my State, to kill a slave; that if a slave is treated with inhumanity, the laws provide a mode by which the slave may be taken from the inhuman owner and sold; but the law may make the same provisions in regard to horses and stock. If horses are treated with cruelty and brutality by the owners, the Legislatures of the State in which such owners live may regulate the usage which the owner may make of his horse, and compel him to observe the laws of humanity and mercy in the use even of a dumb beast, as well as of a slave. That only proves that the law makes different regulations in relation to different subjects of property, according to their nature. The law may regulate the use which the owner of real estate may make of his real estate in towns, and does. He cannot establish a potter's field upon his lot; he cannot, I believe, in my State, treat his beasts, horses at least, with barbarity. If he does, he is subject to a penal law that fines him. He cannot murder his slave. He holds possession of the slave, and has the right to the service of the slave, and that is all the property that could exist practically in a slave. A man cannot kill a slave, and barbecue him, and eat him. He would not be disposed to do that. These laws do not interfere with the just use of slave property at all. They permit to the owner of the slave every free and proper use of the slave of which that slave is capable, notwithstanding their object is to preserve the laws of humanity and mercy in the ownership of the slave; and so of a horse. But because the law makes different regulations in relation to different species of property, according to the nature and essence of that property, it does not at all prove that the property in all the classes has the same origin. That origin, as I said before, is in universal usage and custom.”

Mr. Howard: “I would ask the gentleman from Kentucky, with his permission, whether all property has its origin in force? Slavery certainly has.”

Mr. Davis: “Property in a horse has its origin in force. The horse has to be subdued, broken, and reduced to obedience to the laws and usages of his owner; and so of many other things. There is property in wild beasts, in the lion that once prowled in the forest. In many

articles property can exist only by force, and does exist by force.

"But that is immaterial to the issue. Here is first the Constitution declaring, and then here are the courts in all their judgments in which the question came up, deciding that property does exist in slaves, although it has its origin in force and against natural law. Let me read from the decision in the case of *Prigg vs. Pennsylvania*. After quoting the clause of the Constitution for the rendition of fugitive slaves, the court say :

The last clause is that, the true interpretation whereof is directly in judgment before us. Historically, it is well known that the object of this clause was to secure to the citizens of the slaveholding States the complete right and title of ownership in their slaves, as property, in every State in the Union into which they might escape from the State where they were held in servitude. The full recognition of this right and title was indispensable to the security of this species of property in all the slaveholding States; and, indeed, was so vital to the preservation of their domestic interests and institutions, that it cannot be doubted that it constituted a fundamental article, without the adoption of which the Union could not have been formed. Its true design was to guard against the doctrines and principles prevalent in the non-slaveholding States, by preventing them from intermeddling with, or obstructing or abolishing the rights of the owners of slaves.—*16 Peters's Reports*, p. 611.

"Could anything be more clear or specific? Here the right of property of the owner in the slave is fully recognized by the decision of the Supreme Court. That decision was rendered by Mr. Justice Story, and all the other members of the court sanctioned and approved the same principle. He states it as a matter of history that the incorporation of the article recognizing the full right of the owners of slaves to that property and providing that if they escaped and went into other States the laws of those other States should in no degree and to no extent interfere with the right of the owner to the slave, was the essential condition upon which the Constitution was formed and without which it never would have been formed. Any gentleman who reads Mr. Madison's Papers, in which he gives the propositions and debates of the convention upon the subject of slavery, will, if his mind is not wholly obfuscated by prejudice, give immediate consent to the proposition here laid down by Judge Story. I could refer to a dozen cases decided by the Supreme Court of the United States and by the circuit court of Ohio, of which Judge McLean was presiding judge, recognizing in the most distinct and unqualified terms the right of property of the owner of a slave. There have been various cases tried in that State and in Indiana, and in Michigan, in which all these questions came up, and in every solitary case it was urged in the clearest and most conclusive legal logic that the right of the master to pursue his slave and take him wherever he found him without committing a breach of the peace, was secured to him by the Constitution and by the fugitive slave law; and that if any citizen interfered with that right and aided the

slave in making his escape, that citizen should respond to the claimant of the slave in the amount of the damages which he sustained by such interference. The ordinance of 1787 has a peculiar provision in relation to the reclamation of slaves. There was a slave sought to be reclaimed from Indiana in contravention to that provision—I have the case here—and Judge McLean decided explicitly that the provision of the Constitution of the United States and the fugitive slave law controlled and overruled the provision in the ordinance of 1787, and authorized the reclamation of the slaves precisely according to the letter of the Constitution and of the fugitive slave law."

The question was subsequently taken on the bill, when it was passed by the following vote :

YEAS.—Messrs. Anthony, Browning, Chandler, Clark, Collamer, Dixon, Doolittle, Fessenden, Foote, Foster, Grimes, Hale, Harlan, Harris, Howard, Howe, King, Lane of Indiana, Lane of Kansas, Morrill, Pomeroy, Sherman, Sumner, Ten Eyck, Trumbull, Wade, Wilkinson, Willmot, and Wilson of Massachusetts—29.

NAYS.—Messrs. Bayard, Carlile, Davis, Henderson, Kennedy, Latham, McDougall, NeSmith, Powell, Saulsbury, Stark, Willey, Wilson of Missouri, and Wright—14.

The debate in the House on this bill was brief. Mr. Nixon, of New Jersey, Mr. Blair, of Missouri, Mr. Bingham, Mr. Riddle, of Ohio, and Mr. Crittenden, of Kentucky, were the principal speakers.

Mr. Crittenden thus expressed his views of the measure: "The immediate question before us is the abolition of slavery in the District of Columbia. That is the object proposed in the bill under consideration. It has been a question for a long time agitating the country. For the first thirty or forty years of our existence as a nation, the records of Congress bear no evidence of any such motion ever having been made, of any measure having ever been proposed for the abolition of slavery here, or to change the condition in which the Government accepted and found it. It was only, sir, when a new spirit sprung up in the land, when a new agitation commenced for the abolition of slavery generally, that this feeling concentrated, in some degree, upon the District of Columbia, and from that time down to the present, with an always persevering purpose, this measure has been pressed. It has been rejected time and again. It has been judged impolitic by our predecessors, or beyond their power. For one reason or another, Congress has always refused to act upon the subject. These are the lessons of the past. In the earliest and purest and best and palmiest days of the Republic no attempt was ever made to pass such a measure; and for the last twenty-five or thirty years it has been presented only to be rejected. The Senate of the United States has now given its sanction to the measure, and it is before you for your final consideration.

"Of all inauspicious times, it seems to me

that this is the most inauspicious for the measure which we are called upon to adopt. We are not only engaged in this tremendous war, now, I trust, coming to its end, but we are engaged in a war founded upon the apprehension of the people that it is the intention of Congress ultimately to violate the constitutional rights of the different States in adopting or rejecting slavery as they please. It is that apprehension which has kindled this war. No one will dispute that. Whether it was the real motive with this or that leader, or whether they had other and more traitorous views, it is not necessary to determine.

"The masses of the people, so far as they were influenced by any political considerations, were, I say, influenced to unite in this rebellion by the apprehension of such an intention on the part of Congress. I believed then, and I believe now, that they are mistaken, and that the Congress of the United States will not exercise any such unconstitutional power over them. But that was their apprehension. They are now laboring under that apprehension. Under that apprehension they have fought with fury against us. Out of that apprehension has been attempted to be deduced by the leaders of the rebellion every motive to continued resistance and to everlasting hostility to us. That is our condition now, and it is under these circumstances that this bill is introduced, and we are asked to pass it. What will be the effect of it? Will it not, in the minds of the suspicious, and even of the unsuspecting, strengthen an opinion that that is the purpose of Congress? If it were entirely unconnected with any question of slavery in the States, it might be of less importance; but in principle and in character it is connected with it, and it will be so considered, at any rate, by those in rebellion. It will be considered as an evidence of the general purpose and intent of Congress. I do not say that you have not the power; but would not that power be, at such a time as this, most unwisely and indiscreetly exercised. That is the point. Of all the times when an attempt was ever made to carry this measure, is not this the most inauspicious? Is it not a time when the measure is most likely to produce danger and mischief to the country at large? So it seems to me.

"But are the views of gentlemen limited merely to giving to the slaves of this District the benefit of the law? Those who urge it will have more candor than to say so. They do not limit their views merely to the locality of this District. No, sir, it is the commencement of a great system; it is the beginning, not the end. You try your power here. You execute it here. This thing done, it opens the prospect of further action, and of further disturbance of the community. Having done it here, where it involves, perhaps, in the judgment of men, nothing but a mere question of good faith, the measure can be effected elsewhere, where it will involve a question scarcely

less vital—a question of constitutional power. You are trying your strength now. You are practising for the greater combat. From this ground, occupied as a sort of camp for the purpose, it is suspected you intend to make war on the same institution in the States.

"It seems to me, Mr. Chairman, that that apprehension will be increased by another thing, by another consideration. This measure might be of itself of but little significance, if it could be entirely limited to the District of Columbia. If that was to be 'the be-all and the end-all' of it, it might not be a thing worth debating. But, sir, we cannot avoid connecting it with the whole system that has been presented to us here for the abolition of slavery elsewhere. There are now on our table from ten to twenty propositions of one sort or another, all contemplating the confiscation, or, in terms, the liberation of the slaves of the people of the United States. This is one of them. The public mind cannot avoid making the connection. This is but one link in the chain, and a small one; but it is a link in the mighty chain of measures which are in progress here now. It is that which gives it its most disastrous effect. Is there not, then, danger that we create a feeling of apprehension which will disturb our country—to what extent we cannot imagine? The weary rebels, who are now fainting under the defeats which our brave army has inflicted on them, will feel a new desperation with every new assurance that peace is to bring the spoliation of their property of all descriptions. It will inspire an instinctive spirit of hostility and desperation. That is the nature of man."

The vote was finally taken in the House on the bill with the following result:

YEAS.—Messrs. Aldrich, Alley, Arnold, Ashley, Babbitt, Baker, Baxter, Beaman, Bingham, Francis P. Blair, Samuel S. Blair, Blake, George H. Browne, Buffinton, Campbell, Chamberlin, Clark, Colfax, Frederick A. Conkling, Roscoe, Conkling, Covode, Davis, Dawes, Delano, Diven, Duell, Dunn, Edgerton, Edwards, Eliot, English, Fenton, Fessenden, Fisher, Franchot, Frank, Gooch, Goodwin, Granger, Haight, Hale, Hanchett, Harrison, Hickman, Hooker, Hutchins, Julian, Kelley, Francis W. Kellogg, Killinger, Lansing, Loomis, Lovejoy, McKnight, McPherson, Mitchell, Moorhead, Anson P. Morrill, Justin S. Morrill, Nixon, Odell, Olin, Patton, Pike, Poffter, Potter, Alexander H. Rice, John H. Rice, Riddle, Edward H. Rollins, Sargent, Sedgwick, Shanks, Sheffield, Shellabarger, Sloan, Spaulding, Stevens, Stratton, Benjamin F. Thomas, Train, Trowbridge, Van Horn, Van Valkenburg, Verree, Wallace, E. P. Walton, Washburne, Wheeler, Albert S. White, Wilson, and Windom—92.

NAYS.—Messrs. Allen, Joseph Baily, Biddle, Jacob B. Blair, William G. Brown, Casey, Crittenden, Delaplaine, Dunlap, Grider, Hall, Harding, Holman, Johnson, Knapp, Law, Lazear, Mallory, Menzies, Morris, Noble, Norton, Nugen, Pendleton, Perry, Price, James S. Rollins, Shiel, John B. Steele, William G. Steele, Francis Thomas, Vallandigham, Voorhees, Wadsworth, Ward, Chilton A. White, Wickliffe, and Wright—38.

After being signed by the President it was returned to the Senate with the following Message:

*Fellow Citizens of the Senate  
and House of Representatives:*

The act entitled "An act for the release of certain persons held to service or labor in this District of Columbia," has this day been approved and signed.

I have never doubted the constitutional authority of Congress to abolish slavery in this District; and I have ever desired to see the national capital freed from the institution in some satisfactory way. Hence there has never been in my mind any question upon the subject except the one of expediency, arising in view of all the circumstances. If there be matters within and about this act which might have taken a course or shape more satisfactory to my judgment, I do not attempt to specify them. I am gratified that the two principles of compensation and colonization are both recognized and practically applied in the act.

In the matter of compensation, it is provided that claims may be presented within ninety days from the passage of the act, "but not thereafter;" and there is no saving for minors, *femmes covert*, insane, or absent persons. I presume this, is an omission by mere oversight, and I recommend that it be supplied by an amendatory or supplemental act.

ABRAHAM LINCOLN.

April 16, 1862.

In the Senate, on the 11th of February, Mr. Sumner offered the following resolutions:

*Resolutions declaratory of the relations between the United States and the territory once occupied by certain States, and now usurped by pretended Governments, without constitutional or legal right.*

Whereas, certain States, rightfully belonging to the Union of the United States, have through their respective governments wickedly undertaken to abjure all those duties by which their connection with the Union was maintained; to renounce all allegiance to the Constitution; to levy war upon the national Government; and, for the consummation of this treason, have unconstitutionally and unlawfully confederated together, with the declared purpose of putting an end by force to the supremacy of the Constitution within their respective limits; and whereas this condition of insurrection, organized by pretended governments, openly exists in South Carolina, Georgia, Florida, Alabama, Mississippi, Louisiana, Texas, Arkansas, Tennessee, and Virginia, except in Eastern Tennessee and Western Virginia, and has been declared by the President of the United States, in a proclamation duly made in conformity with an act of Congress, to exist throughout this territory, with the exceptions already named; and whereas the extensive territory, thus usurped by these pretended governments and organized into a hostile confederation, belongs to the United States, as an inseparable part thereof, under the sanctions of the Constitution, to be held in trust for the inhabitants in the present and future generations, and is so completely interlinked with the Union that it is forever dependent thereupon; and whereas the Constitution, which is the supreme law of the land, cannot be displaced in its rightful operation within this territory, but must ever continue the supreme law thereof, notwithstanding the doings of any pretended governments acting singly or in confederation, in order to put an end to its supremacy: therefore,

1. *Resolved*, That any vote of secession or other act by which any State may undertake to put an end to the supremacy of the Constitution within its territory is inoperative and void against the Constitution, and when sustained by force it becomes a practical abdication by the State of all rights under the Constitution, while the treason which it involves still further works an instant forfeiture of all those functions and powers essential to the continued existence of the State as a body politic, so that from that time forward the territory falls under the exclusive jurisdiction of Congress, as other territory, and the State being, according to the language of the law, *seco-de-se*, ceases to exist.

2. *Resolved*, That any combination of men assuming to act in the place of such State, and attempting to in-snarre or coerce the inhabitants thereof into a confederation hostile to the Union, is rebellious, treasonable, and destitute of all moral authority; and that such combination is a usurpation, incapable of any constitutional existence, and utterly lawless, so that everything dependent upon it is without constitutional or legal support.

3. *Resolved*, That the termination of a State under the Constitution necessarily causes the termination of those peculiar local institutions which, having no origin in the Constitution or in those natural rights which exist independent of the Constitution, are upheld by the sole and exclusive authority of the State.

4. *Resolved*, That slavery being a peculiar local institution, derived from local laws, without any origin in the Constitution or in natural rights, is upheld by the sole and exclusive authority of the State, and must therefore cease to exist legally or constitutionally when the State on which it depends no longer exists; for the incident cannot survive the principal.

5. *Resolved*, That in the exercise of its exclusive jurisdiction over the territory once occupied by the States, it is the duty of Congress to see that the supremacy of the Constitution is maintained in its essential principles, so that everywhere in this extensive territory slavery shall cease to exist practically, as it has already ceased to exist constitutionally or legally.

6. *Resolved*, That any recognition of slavery in such territory, or any surrender of slaves under the pretended laws of the extinct States by any officer of the United States, civil or military, is a recognition of the pretended governments, to the exclusion of the jurisdiction of Congress under the Constitution, and is in the nature of aid and comfort to the rebellion that has been organized.

7. *Resolved*, That any such recognition of slavery or surrender of pretended slaves, besides being a recognition of the pretended governments, giving them aid and comfort, is a denial of the rights of persons who, by the extinction of the States, have become free, so that, under the Constitution, they cannot again be enslaved.

8. *Resolved*, That allegiance from the inhabitants and protection from the Government, are corresponding obligations, dependent upon each other, so that while the allegiance of every inhabitant of this territory, without distinction of color or class, is due to the United States, and cannot in any way be defeated by the action of any pretended government, or by any pretence of property or claim to service, the corresponding obligation of protection is at the same time due by the United States to every such inhabitant, without distinction of color or class; and it follows that inhabitants held as slaves, whose paramount allegiance is due to the United States, may justly look to the national Government for protection.

9. *Resolved*, That the duty directly cast upon Congress by the extinction of the States is reinforced by the positive prohibition of the Constitution that "no State shall enter into any confederation," or "without the consent of Congress keep troops or ships-of-war in time of peace or enter into any agreement or compact with another State," or "grant letters of marque and reprisal" or "coin money," or "emit bills of credit," or "without the consent of Congress lay any duties on imports and exports," all of which have been done by these pretended governments, and also by the positive injunction of the Constitution, addressed to the nation, that, "the United States shall guarantee to every State in this Union a republican form of government;" and that in pursuance of this duty cast upon Congress, and further enjoined by the Constitution, Congress will assume complete jurisdiction of such vacated territory where such unconstitutional and illegal things have been attempted, and will proceed to establish therein republican forms of government under the Constitution; and in the execution of this trust will provide carefully for the protection of all the inhabitants thereof, for the security of families, the organization of labor,



the encouragement of industry, and the welfare of society, and will in every way discharge the duties of a just, merciful, and paternal government.

Subsequently Mr. Davis, of Kentucky, submitted the following on the same subject:

1. *Resolved*, That the Constitution of the United States is the fundamental law of the Government, and the powers established and granted, and as pointed out and vested by it, the limitations and restrictions which it imposes upon the legislative, executive, and judicial departments, and the States, and the rights, privileges, and liberties which it assures to the people of the United States and the States, respectively, are fixed, permanent, and immutable through all the phases of peace and war, until changed by the power and in the mode prescribed by the Constitution itself; and they cannot be abrogated, restricted, enlarged, or differently apportioned or vested, by any other power or in any other mode.

2. *Resolved*, That between the Government and the citizen, the obligation of protection and obedience form mutual rights and obligations; and to enable every citizen to perform his obligations of obedience and loyalty to the Government, it should give him reasonable protection and security in such performance; and when the Government fails in that respect, for it to hold the citizen to be criminal in not performing the duties of loyalty and obedience, would be unjust, inhuman, and an outrage upon this age of Christian civilization.

3. *Resolved*, That if any powers of the Constitution or Government of the United States, or of the States, or any rights, privileges, immunities, and liberties of the people of the United States, or of the States, are or may hereafter be suspended by the existence of this war, or by any promulgation of martial law, or by the suspension of the writ of *habeas corpus*, immediately upon the termination of the war, such powers, rights, privileges, immunities, and liberties would be resumed, and would have force and effect as though they had not been suspended.

4. *Resolved*, That the duty of the Congress to guaranty to every State a republican form of government, to protect each of them against invasion, and, on the application of the Legislature or Executive thereof, against domestic violence; and to enforce the authority, Constitution, and laws of the United States in all the States, are constitutional obligations which abide all times and circumstances.

5. *Resolved*, That no State can, by any vote of secession, or by rebellion against the authority, Constitution, and laws of the United States, or by any other act, abdicate her rights and obligations under that Constitution or those laws, or absolve her people from their obedience to them, or the United States from their obligation to guaranty to such State a republican form of government, and to protect her people by causing the due enforcement within her territories of the authority, Constitution, and laws of the United States.

6. *Resolved*, That there cannot be any forfeiture or confiscation of the rights of person or property of any citizen of the United States who is loyal and obedient to the authority, Constitution, and laws thereof; or of any person whatsoever, unless for acts which the law has previously declared to be criminal, and for the punishment of which it has provided such forfeiture or confiscation.

7. *Resolved*, That it is the duty of the United States to subdue and punish the existing rebellion, by force of arms and civil trials, in the shortest possible time, and with the least cost to the people, but so decisively and thoroughly as to impress upon the present and future generations as a great truth that rebellion, except for grievous oppression of Government, will bring upon the rebels incomparably more of evil than obedience to the Constitution and the laws.

8. *Resolved*, That the United States Government should march their armies into all the insurgent States and promptly put down the military power which they have arrayed against it, and give protection and secu-

rity to the loyal men thereof, to enable them to reconstruct their legitimate State governments, and bring them and the people back to the Union and to obedience and duty, under the Constitution and the laws of the United States, bearing the sword in one hand and the olive branch in the other; and whilst inflicting on the guilty leaders condign and exemplary punishment, granting amnesty and oblivion to the comparatively innocent masses. And if the people of any State cannot or will not reconstruct their State government and return to loyalty and duty, Congress should provide a government for such State as a territory of the United States, securing to the people thereof their appropriate constitutional rights.

No special debate took place on the first series of these resolutions. They did not meet with favor either in Congress or among the people.

In the House, on the 10th of March, the following resolution was introduced by Mr. R. Conkling. The resolution was recommended by the President in his Message to Congress on the 6th of March. (See PUBLIC DOCUMENTS.)

*Resolved by the Senate and House of Representatives of the United States in Congress assembled*, That the United States ought to cooperate with any State which may adopt gradual abolishment of slavery, giving to such State pecuniary aid, to be used by such State in its discretion, to compensate for the inconveniences, public and private, produced by such change of system.

A motion was made to postpone the consideration of the resolution, which was lost. Mr. Wickliffe, of Kentucky, then took the floor. He asked: "Where, sir, do you find the power in the Constitution to appropriate the money of the people to carry out the purposes of this resolution? I made the same pertinent inquiry yesterday, and the response was that it was to be found in the preamble of the Constitution of the United States, in the words 'to provide for the general welfare.' It was alleged that it was competent for the legislative department of the Government, under these words in the preamble of the Constitution, 'to provide for the general welfare,' to do anything and everything which could be considered as promotive of the general welfare. I have spent some time in the practice of my profession; I have spent some portion of my life in the public service, especially in the halls of legislation, national and State, yet in all my life I have never before heard any lawyer or statesman claim the right or the power under the recitals in the preamble of the Constitution which is now so boldly asserted. Never before this present Congress have I heard that any such power was delegated under the phrase in the preamble in the Constitution, 'provide for the general welfare.' Under this pretence of power, Congress might think that it would be advancing the interests of the General Government to dot the whole country over with turnpikes, railroads, and bridges, or with schools and colleges, or to do anything or everything that a legislative body, unrestrained by a constitution, may do for the benefit of the people. I thought that this idea of a general-welfare power had long since been exploded by our statesmen and

jurists and courts whenever it was attempted to be asserted in the State or Federal tribunals. If you were to allow that to be taken as a granting power in the Constitution, then there is no limit to which the Federal Government or Congress may not go.

"But we are told that this measure is to be consummated under the war power. It is alleged that we are now in a state of war, and we are told that the Constitution is, therefore, to be disregarded. It is said that whatever is necessary to carry on this war to a successful conclusion, may be done with perfect freedom under the license and authority, not of the Constitution, but as a military necessity. I deny that a state of war, and especially the present state of war, enlarges the power of Congress. I believe that Congress is vested with no more power than the people have already given to it for the purpose of doing all that is necessary and proper to carry on this or any other war.

"Is it necessary and proper, while pretending to restore this Constitution all over the territory of the United States, that we should repudiate the authority and power of the Constitution? I greatly fear there are many who desire more the emancipation of the slaves of the South than the restoration of the Union of the States. If it had not been for that strong desire, I think that we would never have heard of this military-necessity power."

Mr. Diven, of New York, replied: "The distinguished gentleman from Kentucky (Mr. Wickliffe) inquired under what clause of the Constitution the power was derived by which we could enact a law providing for the payment of emancipated slaves. Sir, it seems to me it is too late to raise or discuss that question. It has long since been passed upon; and if the testimony of distinguished statesmen, lawyers, and jurors in times past will have weight with the gentleman, I can mention, I think, a number of cases in which the same question was involved and passed upon. I can remind him of an early day when a bill was introduced into this Congress, when Kentucky was represented on this floor by one of her sons of whom she is always proud, a bill was introduced making an appropriation for the establishment of an asylum for the deaf and dumb, when this very question of want of power to make such an appropriation was raised, and it was most eloquently and successfully answered by Henry Clay, in which the existence of the power in Congress to pass laws having reference to the amelioration of the condition of any portion of the people of the country was regarded as within the scope of the Constitution.

"Well, sir, from that time down to the present, the question has often been raised as to the appropriation of the money of the United States or the property of the United States for the benefit or amelioration of citizens of the United States, and it has always been acquiesced in, and appropriations have been made from

time to time the purpose of which was the education or aid of the unfortunate. There are many instances which I could mention. I have not taken the pains to brief the cases; but I am reminded by my colleague of the expedition to the Dead Sea, an expedition for scientific purposes, for the increase of general knowledge. I place this resolution upon the ground that it is for the amelioration of a race of men, most unfortunately, as I think, placed upon this continent. Another gentleman mentions the case of affording relief to the starving poor of Ireland. Yes, sir, if I were to receive the suggestion of all the cases which could be mentioned in which this power has been exercised by Congress, I should occupy the time of the House for a long period. It is too late, in my judgment, to raise this question."

Mr. Fisher, of Delaware, said: "I rather view it as an olive branch of peace and harmony and good faith presented to the border States, and indeed to all the Southern States—even those which have seceded. I see in its adoption a settlement and a final settlement of all angry discussion and agitation upon this terrible question of slavery, which comes up here and in almost all public deliberative bodies in this country, like Satan among the sons of God, to afflict and destroy our happiness and prosperity. I hear, in its kindly invitation, the voice of the mighty North, composed of twenty millions of free white men—men who labor for themselves—having the power now to overrun and lay waste the entire southern country and liberate its slaves."

Mr. Hickman, of Pennsylvania, followed, saying: "It is, in my judgment, simply a declaration of opinion as to a policy, and nothing more. As I look at it, it is rather a compensation to the North for disappointed hopes, and a warning to the people of the border Slave States, who are most interested at the present moment in the subject to which it makes special reference. The President of the United States cannot be ignorant of the fact that he has, thus far, failed to meet the just expectation of the party which elected him to the office he holds; and his friends are to be comforted, not so much by the resolution itself as by the body of the Message, while the people of the border Slave States will not fail to observe that with the comfort to us is mingled an awful warning to them."

The vote was subsequently taken on the resolution and it was adopted. Ayes, 89; noes, 31.

In the Senate, on the 24th of March, this resolution as adopted by the House, was considered.

Mr. Saulsbury, of Delaware, took the floor, saying: "It is to my mind the most extraordinary resolution that was ever introduced into an American Congress; extraordinary in its origin; extraordinary in reference to the source from whence it proceeds; extraordinary in the object which it contemplates; mischievous in

its tendency; and I am not at all sure that it is anywise patriotic, even in its design. Sir, it is an ignoring of the policy which has always been proclaimed by the party now in power. I am not a member of that party, and I thank my God to-day that I never was and never expect to be, especially after the introduction of such a resolution as this into the Congress of the United States. What was the declaration made by that party before the recent presidential election? What have been their declarations ever since they came into power? It was that they did not intend nor contemplate any interference with the subject of domestic slavery within the States.

"It is folly to say that this is not an interference with the domestic institution of slavery in the States. To be sure, it does not propose, by force and in terms, to liberate the slaves in the slaveholding States. It does not say, "If you do not emancipate them, we will;" but it is an interference in this wise and to this extent: it is an attempt to awaken a controversy in those States, to initiate emancipation in those States, to commence the work of abolition in those States, by holding out pecuniary aid to the States, by holding out an inducement. That is virtually as much an interference as though they had proposed directly and by force to liberate the slaves in those States. It is not an interference of the same character and of the same kind; but still it is an interference with the subject of domestic slavery within the States.

"Now, sir, where is the propriety for the introduction of such a resolution as this? Has any one of those States asked your aid? Has any one of them suggested that they would like to be relieved from this incubus of slavery, if incubus it be? Have they called upon you for advice? Have the persons interested in this question sent any petition here asking the Congress of the United States to aid them in the work of emancipation? If they have not asked your aid, I submit that your proffered aid is not very delicate, to say the least of it; and when I say this, I say it because, representing one of those States, the smallest slaveholding State in the Union, I have a right to say it, because my State has said it.

"But, sir, there is another consideration involved in this resolution. I should like some one of the members of the Judiciary Committee, who are presumed to be gentlemen learned in the law, to show me any authority in the Constitution of the United States for this Government to apply money in freeing the slaves in the States."

Mr. Davis, of Kentucky, offered the following amendment:

Although the whole subject of slavery in the States is exclusively within the jurisdiction and cognizance of the government and people of the States respectively having slaves, and cannot be interfered with directly or indirectly by the Government of the United States, yet when any of those States or their people may determine to emancipate their slaves, the

United States will pay a reasonable price for the slaves they may emancipate, and the cost of their colonization in some other country.

Mr. Sherman, of Ohio, objected to the amendment. He thought the President's resolution carefully excluded the idea that Congress had any right to interfere with slavery in the States. It contained two or three simple propositions. One was that, whenever any State desired to relieve itself of the existence of slavery, the General Government would help that State to the extent of its ability, without pointing out the mode or manner. It was a simple proposition. It recognized the right of each State to regulate and control its domestic institutions in the broadest terms. The language was simple and plain. He hoped, therefore, that no amendment would be allowed to pass.

Mr. Davis, of Kentucky, admitted that the general principle both of the original resolution and of the substitute which he had offered was the same; but the substitute proceeded to define the nature and the extent of the assistance that the Congress of the United States was disposed to give to the States where slavery existed or to individual slaveholders in those States, provided they should proceed in the work of emancipation. He wanted Congress to express its will and its purpose in relation to that particular view of this subject. The original resolution on that point was wholly indefinite.

Mr. Doolittle, of Wisconsin, desired to say that he understood the resolution suggested by the President covered two ideas: first, emancipation by the States at their own pleasure, in their own way, either immediately or gradual; and, second, the idea of colonization, a thing believed to be necessary to go along side by side with emancipation by nine tenths of the people of the States interested, and without which they declare emancipation impossible. The resolution did not mention compensation or colonization either, but implied and looked to both.

Mr. Saulsbury, of Delaware, said: "It is all folly to say that the proposition made by the President is the same as that made by the Senator from Kentucky. The Senator from Kentucky proposes, in plain words, to pledge the faith of this Government that the value of the slaves shall be paid upon emancipation. The proposition of the President promises nothing. It does not say that slaveholders, when the slaves are liberated, shall ever receive a dollar. It is a vague, unmeaning proposition, saying that Congress ought to cooperate; not saying that Congress will, not saying how Congress shall cooperate, not saying that Congress shall pay the value of the slaves, as is said by the proposition of the Senator from Kentucky."

Mr. Browning, of Illinois, insisted that the joint resolution did not propose any interference whatever on the part of the General Government with the question of slavery in the States or elsewhere. It was simply a declara-

tion that, in the event of any State hereafter choosing to enter upon a system of gradual emancipation of slaves, or gradual abolishment of slavery, the United States ought to cooperate with that State by giving it pecuniary aid, to be used by the State, in its discretion, to compensate for the inconveniences, public and private, produced by such change of system.

Mr. McDougall, of California, expressed his views thus: "I have learned in the school wherein I studied the Constitution of my country, that this Federal Government was one of limited powers, contained and defined in the grant of powers, and that nothing was granted to this Federal Government but for the purposes of administration and government—for public and general purposes. Is there or is there not any limitation upon the Federal Government in disposing of the moneys assessed upon the people, and brought into the Federal Treasury? May it or may it not be expended for any and for every purpose? If they can be expended for all purposes or for any purpose in the will of Congress, then there can be no objection to this measure, so far as the question of power is concerned. But if there be a limitation, I would ask what limitation? And then, if I were to answer the question I asked, I would for its resolution look to the Constitution. It is not at this time denied but that the Federal power is power granted by the terms, express or implied, in the Constitution. The power granted is the limit of power. The question then is, Is this a power granted? That is, the power to take money from the Federal Treasury, not for the purposes of government, not for any purpose indicated in that instrument, but as a charity to any one of the States of the Union who may come and ask a particular charity at its hands. I do not myself, with the instructions I have had, understand that we have the constitutional right to make ourselves almoners for the States of this Union any more than we have for the States of Europe."

The amendment of Mr. Davis was lost—ayes 4, noes 84—and the resolution was subsequently passed, as follows:

YEAS.—Messrs. Anthony, Browning, Chandler, Clark, Collamer, Davis, Dixon, Doolittle, Fessenden, Foot, Foster, Grimes, Hale, Harlan, Henderson, Howard, Howe, King, Lane of Indiana, Lane of Kansas, Morrill, Pomeroy, Sherman, Sumner, Ten Eyck, Thomson, Trumbull, Wade, Wilkinson, Willey, Wilmot, and Wilson of Massachusetts—32.

NAYS.—Messrs. Bayard, Carlile, Kennedy, Latham, Nesmith, Powell, Saulsbury, Stark, Wilson of Missouri, and Wright—10.

The resolution, as adopted, was as follows:

That the United States ought to cooperate with any State which may adopt gradual abolishment of slavery, giving to such State pecuniary aid, to be used by such State in its discretion, to compensate for the inconveniences, public and private, produced by such change of system. (See PUBLIC DOCUMENTS.)

In the Senate, on the 25th of February, the bill "to confiscate the property of rebels," &c., was taken up.

The confiscation of the property of the people of the seceded States became a subject of great interest at this session of Congress. It was anticipated by those members who introduced the proposition before Congress, that by an act of this nature the slaves could be reached and emancipated. The views presented in favor of, and against this measure, possess the highest importance.

Mr. Trumbull, of Illinois, took the floor to explain the bill. He said: "The bill is intended to operate upon property, and not to affect the person of the rebel or traitor; and it only operates upon the property belonging to such rebels as are beyond the jurisdiction of the courts in the ordinary course of judicial proceeding. Where the rebel can be reached by judicial process, the punishment for his crimes can be visited upon him personally, and this bill does not propose to interfere with his property at all. It does not touch that class of cases; and one reason why it does not was to steer clear of any difficulty growing out of this clause in the Constitution of the United States:

The Congress shall have power to declare the punishment of treason; but no attainder of treason shall work corruption of blood or forfeiture, except during the life of the person attained.

"Under that clause of the Constitution, I have been inclined to the opinion that it was not competent for Congress to forfeit the real property of a convicted traitor, except during life; and as the punishment for treason by our law is death, the forfeiture of his realty for life would amount, of course, to very little. But I understand that it is competent for the Congress of the United States to prescribe a punishment for those persons who, though aiding and abetting the rebellion, cannot be reached and prosecuted for treason; and this bill applies to that class of persons. They may be non-residents; they may be foreigners; for instance, an Englishman owning property in the city of New York may be contributing to this rebellion—may be aiding it. I do not understand that Congress is without power to punish such a person, by confiscating his property. He may aid the rebellion by contributing the very means derived from his property in New York to the support of the army which is now arrayed against the Government. I wish to put this question to those who doubt the constitutionality of this bill, if there are such: I wish to ask them if it is not competent for Congress to reach that class of cases?

"This bill also provides for reaching the property of all rebels in States where the judicial authorities are overborne. It is manifestly impossible to try a man for treason in South Carolina. You cannot practically carry out the provisions of the Constitution which guarantee to a man a jury trial, and also make it necessary that he should be indicted before he is put on his trial, where you have no courts. It is because these persons are beyond the

reach of judicial process that I suppose their property may be reached in this way. As our armies advance into the South, if this bill becomes a law, all the property belonging to these rebels, as fast as we get possession of it, will be appropriated to the use of the Government: it is forfeited by the act.

"I know that some have objected that this bill amounts to nothing; that we have not possession of this property. Why declare, they say, the slaves of rebels free, and why forfeit and confiscate the property of rebels when, for want of possession of the property and slaves, the law can have no practical effect? But if you pass such a law as this, and it goes into effect immediately, you may take possession of this property next year or any time hereafter; the forfeiture is effected; the title is divested in these military districts; and in the other districts of the United States where there is property belonging to non-resident rebels the forfeiture is to be perfected through the courts. Perhaps I had better read two sections of the bill in order to show the mode of forfeiting property. The fourth section provides for the mode of doing this where judicial authority is overborne. It declares

That it shall be the further duty of the President of the United States, as often as in his opinion the military necessities of the army, or the safety, interest, and welfare of the United States, in regard to the suppression of the rebellion, shall require, to order the seizure and appropriation, by such officers, military or civil, as he may designate for the purpose, of any and all property confiscated and forfeited under and by virtue of this act, situated and being in any district of the United States beyond the reach of civil process in the ordinary course of judicial proceedings by reason of such rebellion, and the sale or other disposition of said property, or so much of it as he shall deem advisable.

"Under that provision it will be perceived that the President may appoint persons to take possession of this property as our armies advance, and he may order the sale of it. Under this section of the bill, we go through no judicial proceeding whatever for the purpose of condemning this property. Confiscation is not a judicial matter in regard to this property. You cannot condemn the property by a judicial proceeding, because you have no court there to do it. The very fact of the existence of the rebellion and of the necessity to call out the army for the purpose of putting it down, presupposes that your judicial tribunals are overborne, and this confiscation of the property is to be made effective through the military tribunals. I think this may be done.

"We have toward these people in the rebellious States a twofold right. There would be no difficulty in determining our rights as against them if they were an independent nation; but what makes the difficulty is the relation which the persons in arms against the Government bear to it, that is, as enemies, and at the same time as citizens. That is what seems to embarrass some minds. That is the precise condition that persons now in arms against the United

States in the rebel States are in. We may treat them as traitors, and we may treat them as enemies, and we have the right of both, belligerent and sovereign, so far as they are concerned.

"When an insurrection assumes such formidable proportions as the present, and when armies are arrayed against each other and the power of the nation called forth to put it down, the international law writers all agree that the rebels are entitled to be treated as belligerents or as enemies. We have been treating the rebels in the South as belligerents during this present war. We have sent flags of truce to them. We have taken them as prisoners of war. Whenever a rebellion becomes of such magnitude as to be entitled to be called a civil war, then the rights of the parties are to be governed by the ordinary rules of war between independent nations; but that does not prevent the Government, after the war is over, from trying as a traitor any person that may be in its hands. That is the way, I take it, that this rebellion is to be finally put down. Nobody expects to try for treason the two or three hundred thousand men now in arms against the Government, every one of whom is a legal traitor; but we will give them the rights of belligerents; we will take them as prisoners of war; and when those who have been seduced from their loyalty to the Union shall have returned to their allegiance, we will release them again. But the ringleaders of this rebellion—the instigators of it, the conspirators who set it on foot—will, I trust, be brought to trial for treason, and, if found guilty, be executed as traitors. These are our rights as against rebels.

"One of the rights as against an enemy is the right of confiscation. We have the right to take the persons and the property of our enemy and destroy them both if necessary.

"I desire to call attention for a moment to the second and third sections of this bill, which I regard as among the most important in it. The second section forfeits the right or the claim of any person to the service or labor of any other person, when the person claiming the service has been engaged in any manner in this rebellion, and makes the person owing the service forever afterward free. I take it there can be no doubt of the power of Congress to pass this provision. Congress has authority to raise armies, and it may draft soldiers. It may take the hired man of my friend from Kentucky (Mr. Davis), whom he has engaged at a stipulated price to work upon his farm for the next year, and in the middle of his contract, in the midst of his harvest, the Government of the United States may come along and draft that man into the service of the United States, and what becomes of the contract? Can you enforce it as against the United States? Can you plead that you are entitled to the service for which you had, perhaps, paid in advance? The paramount au-

thority of the Government of the United States may, if necessary, take into its service the employé of any person, and the employer has no remedy.

"The power to do this cannot be questioned; and does the master hold his slave by any stronger tenure? You cannot draw a contract so strong by which one person shall give his time and services to another, that the paramount authority of the Government cannot abrogate that contract, and take from your control the person and bring him into the service of the country. If this can be done in reference to a hired man, or in reference to your own child, why not in reference to a slave? By the laws of nearly all the States of the Union, every parent has the control of his child until he is twenty-one years of age; and yet, notwithstanding, if the necessity requires it, if the public safety demands it, the Government of the United States may take your son at eighteen years of age, or even younger, from under your control, and bring him into the army of the United States and into the battlefield in defence of the honor and integrity of the United States. And does a master hold his slave by any stronger tenure than this? Why, sir, the persons, all the property, everything connected with your enemy, may be taken and condemned and destroyed, if it be necessary to preserve the country; and not only of your enemy, but you may take the property of your friend. We are now taxing the loyal men of this country to the furthest limit, and sacrificing thousands of valuable lives in support of this war. While all this is being done, can it be pretended that we cannot touch the negro of a man who is fighting against the Government?

"The second section of the bill declares that hereafter whenever any person claiming to be entitled to the service or labor of any other person, shall seek to enforce such claim, he shall, in the first instance, and before any order for the surrender of the person whose service is claimed, establish not only his title to such slave as now provided by law, but also that he is and has been during the existing rebellion loyal to the Government of the United States. Is there any hardship in that provision? Will it not be a very easy matter for the owner of any slave, when he sends his agent to reclaim him, to send along the evidence that he himself is loyal to the Government of the United States?

"Another portion of the section prohibits the rendering of fugitives by our military and naval officers, and forbids their undertaking to pass upon the freedom or slavery of any person. Now we have various policies pursued by different commanders. One commander in the West, General Halleck, forbids all fugitive slaves to come within his lines. Now, I want it upon the statute-book that he shall not determine anything about fugitive slaves, that he shall not inquire whether a man is a fugitive slave

or not; and if he knows him to be so, that he shall not surrender him, but shall treat him as a person, as he is, and make no distinction between him and other persons whom he may meet in the country.

"The third section makes provision for the colonization of negroes who may be freed by the act, and are willing to emigrate. There is a very great aversion in the West—I know it to be so in my State—against having free negroes come among us. Our people want nothing to do with the negro. When we tell them that slavery has been the cause of this rebellion, and that the traitors who are fighting us are supported by their slaves, they admit it; but they say: 'What will you do with them; we do not want them set free to come in among us; we know it is wrong that the rebels should have the benefit of their services to fight us; but what do you propose to do with them?' This bill proposes—and it is in harmony with the recommendation of the President of the United States—to colonize them, and it authorizes the President to provide for their settlement in some country beyond the limits of the United States."

Mr. Willey, of Virginia, said: "I should like to have heard the Senator's opinion as to where and how he derives the constitutional power to vest authority in the President of the United States to make provision for the transportation, colonization, and settlement of emancipated negroes; and moreover, if there be such power and we shall be satisfied of its existence, in what manner should the President exercise it? Here is a general duty prescribed, a general authority vested in the President, without any limitation, without any prescription of the manner in which he shall exercise it. Where is he to get the funds? How are they to be raised?"

Mr. Ten Eyck, of New Jersey, also said: "We cannot close our eyes to the state of things which must necessarily exist in the Southern States, where they have this institution of human slavery, by setting at liberty all the slaves that have heretofore belonged or that the rebels have claimed to belong to themselves, and leaving them there in that locality to roam at large under the circumstances in which they will be placed in their ignorance, destitution, want of knowledge, and want of care and providence. What is to become of them, and what is to become, under such a state of things, of the loyal Union men of the South, with millions of freed slaves left to roam the country at large, to go and come when and where they will? I may be mistaken in the view which I take of this case; but it seems to me that if we were by an enactment to declare all the slaves of rebels in the South free, without making provision of some kind for their removal to a district where they may be safe, and where the community may be safe, where they themselves may be taken care of, we may have ruin and destruction and even all the horrors which have been witnessed in some of the West India Isl-

ands reenacted within the borders of the Southern States. It seems to me to be entirely inconsistent with the safety of those communities that such a large body of freed slaves should be kept there uncontrolled and unrestrained except by the power which may exist within those States."

Mr. McDougall, of California, said: "Sir, as far as I am able to read of the wisdom taught by the history and counsellings of the past, the measure now proposed can never secure peace. The policy involved in it will continue an angry, remorseless, relentless war, which, if it do not involve subjugation, will involve extirpation. I fear that the country, and not only the country but the Senate have been led wild with anger; that they have caught some of the angry spirit of their adversaries, and instead of taking lessons from the great states of the world, and the great teachers of ancient and modern times, have taken their advice from Richmond and Montgomery."

Mr. Cowan, of Pennsylvania, followed, in opposition to the bill, saying: "Mr. President, I agree with the honorable Senator from California, and look upon the bill now under consideration as the most important, by far, upon our calendar, involving the gravest questions and most momentous issues. If it passes, I think it will be the great historic event of the times—times which are as fruitful of events as any the world has ever witnessed. Upon the disposition we may make of it, perhaps the fate of the American Republic may depend; and no one surely can overrate the magnitude of anything which may be attended with such consequences.

"We are standing now squarely face to face with questions of most pregnant significance. Shall we stand or fall by the Constitution, or shall we leave it and adventure ourselves upon the wide sea of revolution? Shall we attempt to liberate the slaves of the people of the rebellious States, or shall we leave them to regulate their domestic institutions the same as before the rebellion? Shall we go back to the doctrine of forfeitures which marked the middle ages, and introduce feuds which intervening centuries have not yet sufficed to quiet? These are great questions, and they are in this bill, every one of them. If, for one moment, we can suppose the scheme consummated which it contemplates, we shall have the following results:

"I suppose it is reasonable and moderate to estimate the number of people engaged in the rebellion to be equal to one-half of the whole white population of the confederate States—say four millions. If so, this bill proposes, at a single stroke, to strip all this vast number of people of all their property, real, personal, and mixed, of every kind whatsoever, and reduce them at once to absolute poverty; and that, too, at a time when we are at war with them, when they have arms in their hands, with four hundred thousand of them in the field opposing us desperately.

"Now, sir, it does seem to me that if there was anything in the world calculated to make that four millions of people and their four hundred thousand soldiers in the field now and forever hostile to us and our Government, it would be the promulgation of a law such as this. Will they yield to us sooner in view of such a result to them? What would we be likely to do if they were to threaten us with a similar law? Would we ever, under any circumstances, yield on terms like those? I need hardly ask that question to men descended from sires who refused to pay the tax on teas, and from grandsires who rose in rebellion and overturned a monarchy rather than pay twenty shillings ship money.

"Again: the forfeitures of William the Conqueror, decreed upon the property of the Saxons who followed Harold to the field of Hastings, sink into utter insignificance compared with those enacted in the bill before us. The proud Norman and his rapacious barons were content with the castles and fiefs of the Saxon leaders whom they had overcome; but they did not dare to strip the people, or, indeed, even much to increase their burdens. They knew, victorious and all-powerful as they were, that would have involved them in a new and far more dangerous struggle, in which every peasant would have been a principal combatant, with his all at stake.

"Neither did the English conquerors of Ireland, in their long series of forfeitures and confiscations, from the time of Strongbow down to the rebellion of 1798, ever, at any time, venture upon such a sweeping measure as this; their attainders exhausted themselves upon the Irish nobility, and they never were rash enough to strip the Irish people. I do not know the value of the property forfeited by this bill; I cannot even approximate it, except to say that it is enormous—to be computed by billions. But, sir, the bill goes further, and forfeits a vast amount of property of the rebels which, when forfeited, cannot be confiscated or put into the coffers of the conquerors—I mean their property in negro slaves.

"Now, I do not mean to stop here to discuss their right to this species of property; it is enough for me to say that all the people of the Slave States, loyal and rebellious, seem to agree as to this with a wonderful unanimity, and to resent with an excessive sensibility any interference with it whatever. And, although in the bitterness of the feuds engendered by the civil war now raging among them, the loyalists there would be glad to join in inflicting upon the rebels even the severest punishments, yet this one they abhor and refuse, because they aver that it would be equally injurious to them as to their enemies; and it makes no manner of difference whether that view is correct or not, if they believe it—and this their representatives can tell us. What I mean to say is, that this bill would liberate, perhaps, three millions of slaves; surely the most stupendous stroke

for universal emancipation ever before attempted in the world ; nay, I think it equivalent, if carried out, to a virtual liberation of the whole four millions of slaves in the Union.

"But what is to be the effect of it upon the war? Will we be stronger after it than before; or will we find we have doubled the number of those in arms against us? They have now no cause of war; will not this measure furnish them one, and one they think more just and holy than any other? Let the loyal men who know them also answer this question. I will abide their answer, and submit again that no deliberative assembly in the world ever before sat in judgment upon an issue of such magnitude.

"Not content, however, with this, those who favor this bill seem determined to bewilder and blind us still more by an additional project of greater magnificence and, if possible, of greater difficulty; and that is, in the duty it imposes upon the President, in the third section, of procuring a home for these emancipated millions in some tropical country, and of transporting, colonizing, and settling them there, if they desire to go, with guarantees for their rights as freemen; and this is all provided for in a section of a single sentence of nine lines! Surely, sir, we must have been recently transported away from the sober domain of practical fact, and set down in the regions of eastern fiction, if we can for a moment entertain this proposition seriously. Do the advocates of the scheme propose to confer upon the President the gold-making touch of Midas? One would think the universal menstruum of the philosopher's stone had been at last discovered. Certainly, nothing short of the ring and lamp of Aladdin, with their attendant genii, would enable us in our present condition to assure the President of his ability to enter upon such a task, unless, indeed, it is conceived the Treasury note is of equal potency in this behalf. If so, the sovereign of the tropical country and the transportation companies ought to be consulted in regard to the legal tender clause. I suppose it is not expected that the exodus can be supported on the way by quails and manna; and yet, I am free to say, it will need the miraculous interposition of Heaven quite as much as did that of the Israelites of old.

"But to return: At a time when every energy of the country is put in requisition to suppress the rebellion; when we are in debt equal to our resources of payment, is it not strange that this scheme, which would involve us in a cost more heavy than even the present war, should be so coolly presented for our consideration, and urged to its final consummation with a kind of surprise that any one should oppose it? It is certainly due to ourselves, if not to the country, that we should not be in haste about engaging in such gigantic schemes.

"Then there is a further consideration involved in this bill, of still greater moment than even those I have already glanced at; and that

is, its direct conflict with the Constitution of the United States, requiring us, indeed, should we pass it, to set aside and ignore that instrument in all its most valuable and fundamental provisions; those which guarantee the life, liberty, and property of the citizen, and those which define the boundaries between the powers delegated to the several departments of the Government.

"Pass this bill, sir, and all that is left of the Constitution is not worth much. Certainly it is not worth a terrible and destructive war, such as we now wage for it. And it must be remembered that that war is waged solely for the Constitution, and for the ends, aims, and purposes sanctioned by it, and for no others.

"I am aware, however, that some think the Constitution is a restraint upon the free action of the nation in the conduct of the war, which they suppose could be carried on a great deal better without it, &c. Now, sir, I have no hesitation in saying that no greater mistake ever was made in the world than is made by such people.

"I am, therefore, opposed to this bill, to all and every part of it, except the last two sections, which, although not free from objections, yet these are not of such a serious character but that I could give my assent to them."

Mr. Morrill, of Maine, followed. He thus expressed his views of the power of Congress: "Assuming now the state of the nation to be that of general internal hostility; and that, being so involved, it possesses the power of self-defence, it is still important to inquire in what department of the Government this authority is lodged. Happily this is no longer an open question. The supreme power of making and conducting war is expressly placed in Congress by the Constitution. 'The whole powers of war,' says the Supreme Court of the United States, in *Brown vs. The United States* (1 Cranch), 'are vested in Congress.' Surely all will agree there is no such power in the judiciary, and the Executive is simply 'Commander-in-Chief of the Army and Navy;' all other powers and duties, not necessarily implied in the command of the military and naval forces, are expressly given to Congress. Congress declares war; grants letters of marque and reprisal; makes rules for captures on land and water; raises and supports armies; provides and maintains a navy; makes rules for the government of land and naval forces; provides for organizing, arming, and disciplining the militia, and for governing them in actual service; and is thus invested, in the language of the court, 'with the whole powers of war.'

"In the contingency of actual hostilities the nation assumes a new and extraordinary character, involving new relations and conferring new rights, imposing extraordinary obligations on the citizens, and subjecting them to extraordinary penalties.

"There is then, sir, no limit on the power of Congress; but it is invested with the abso-



lute powers of war—the civil functions of the Government are, for the time being, in abeyance when in conflict, and all State and national authority subordinated to the extreme authority of Congress, as the supreme power, in the peril of external or internal hostilities. The ordinary provisions of the Constitution, peculiar to a state of peace, and all laws and municipal regulations must yield to the force of martial law, as resolved by Congress.”

Mr. Browning, of Illinois, followed in opposition to the bill, the object of which he thought could be easily accomplished under the “war powers” of the Government. He said: “This bill has no reference whatever to captured property, but to that which neither has been nor is expected to be captured. Nor is it restricted to property which, by its character and uses, is adapted to aid the rebellion, but strikes at all the property of every kind and character of all the citizens of the seceded States with scarcely an exception. It sweeps away everything, even the most ordinary comforts and necessaries of domestic life, and reduces all to absolute poverty and nakedness. It leaves them the ownership of nothing, and when executed will leave them the possession and enjoyment of nothing. If the bill is constitutional, the instant it passes millions of people in the private walks of life will be stripped of the ownership of everything, and, the moment the strong arm of power can reach them to execute the law, will also be stripped of the possession of everything. They may repent of their past rebellion and return to their allegiance the next day or the next month, but they return bankrupts and beggars, with nothing on earth to make government desirable.

“But if this bill passes, would they return? What possible inducement would they have to do so? What could they hope or expect from a Government which had shown itself so stern and remorseless in the execution of vengeance, not upon the guilty few, whose vaulting ambition conceived the treason and hatched the rebellion, but upon the deluded masses, who are fitter subjects of commiseration than of vengeance? The sure and certain effect of this bill would be to make peace and reunion an impossible thing. It would fill the hearts of the entire people with despair, and nerve their arms with the energy and desperation which despair inspires. It would turn to the blackness of night the last glimmering hope of future fraternity between now alienated and exasperated brethren.

“A simple statement of the case will, I think, demonstrate our want of power to legislate as proposed. If we recognize the existing state of things as war, then we must also recognize the rebels as public enemies, and deal with them according to the rules of war established by the law of nations, which we cannot change. We must deal with them precisely as we would deal with a foreign nation with which we were at war. And if at war with a foreign nation,

the law of nations would forbid us to pass a law to confiscate the property of the private citizens of that nation, or even to plunder them when our victorious army had invaded their country. I think it will not be contended that we could do either. Our Constitution, I concede, would not restrain us. We would be restrained by the law of nations. We could confiscate all the property which we captured during the progress of the war; but we would do it under the war power, and not by legislation.

“If we do not recognize the rebellion as war and the rebels as public enemies, but as insurgent citizens only, and deal with them and treat them as citizens, then we cannot pass the law proposed, because the Constitution forbids the enactment of bills of attainder, and this is, in the meaning of the Constitution, a bill of attainder.

“When our arms have triumphed and the rebellion is suppressed and the rebels reduced to obedience, the Government will be restored to its authority over them as citizens, and may pass laws of amnesty, embracing all or any part of them, or elect to treat them as traitors, and indict, convict, and punish them for treason. But this must be done in accordance with constitutional provisions and guarantees, and within constitutional limitations; and we could not even then, in the case of a convicted traitor, confiscate to the extent proposed by this bill.

“Thus, Mr. President, whether we regard the rebels as public enemies with whom we are at war, or only as insurgent citizens, we are, in either case, without power to pass the bill under consideration. But in renouncing this power of legislation we renounce no power necessary to the defence of the Government and the maintenance of its authority—the suppression of the rebellion and the condign punishment of the traitors. The powers of the Government for these purposes are ample and plenary. But they are war powers, and not powers of legislation. The inexpediency of this bill is as manifest as its unconstitutionality. Let it pass, and its provisions be heralded in advance of the army as it marches south, and what other effect can it have than to consolidate the entire people for one last despairing struggle against those whom they might then justly regard as enemies and oppressors instead of friends and benefactors? What possible inducement could they have to prefer submission to death? For one, I do not wish to waste the fortunes and devastate the homes of all. Leave something to make the guardianship of Government and the protection of law desirable. Surely it is most desirable, if we can, to win back our erring brethren to their allegiance to and love for the good old Government of our fathers; and if we cannot do this, the success of our effort to put down the rebellion will be almost as disastrous as failure.”

Mr. Carlile, of Virginia, followed in opposition to the bill. He said: “The bill denies to the citizen the constitutional right of testing

the constitutionality of the act before the tribunal created by the Constitution. It would seem as if the authors of the bill, conscious of the unconstitutionality of the proposed measure, purposely framed it so that its constitutionality could not be pronounced upon by the Supreme Court.

"The bill proposes to confiscate to the use of the Government all the property, real and personal, belonging to the citizens of the seceded States who are or may be in the service of the so-called Confederate States, or who in any way give aid and comfort to the rebellion. When it is remembered that the authors of the rebellion were in possession of the various State governments, and used the power and machinery of their respective State governments to compel the people to acquiesce in their unconstitutional acts, and to recognize their usurped authority, it will be seen that all the property of each and every citizen in the seceded States would be forfeited under this bill. Such a sweeping proposition, so unjust and cruel a measure, one better calculated to continue the war forever and exhaust the whole country, never has been in the history of the world, and I predict never will be again, proposed to any legislative assembly representing a civilized community.

"By the bill all the property, except slaves, is to be sold, and the proceeds put into the public treasury. The slaves are to be emancipated in violation of the Constitution and in disregard of the acknowledged constitutional rights of their owners and of the States where in they reside. The want of power in Congress to interfere with slavery in the States where it exists has always heretofore been admitted; the most ultra abolitionists admit that Congress cannot interfere with slavery in the States, and because this is so they denounce the Constitution as a covenant with death and a league with hell."

Mr. Henderson, of Missouri, argued that such measures would not increase the Union feeling at the South or strengthen the hands of the Government. He said: "I have no objection to confiscating the property of the rebel, including his slave; but let it only be done when guilt has been established under the forms of judicial investigation.

"I crave this, not for the sake of the traitor, but for our own sake and in behalf of constitutional liberty. If we cling to the Constitution, whatever is right will yet be accomplished; if we depart from its just restraints no man can tell the excesses of the future. In the midst of storms upon ocean's wilderness, the mariner's only trust is upon his unerring compass. In the midst of a revolution so vast and terrible as the present, with armies in the field even greater than those with which Napoleon brought the nations of Europe to his feet, our only trust is in the Constitution. In the plenitude of power to-day, we may deny mercy to others; to-morrow we may ourselves cling in

vain to the horns of the altar. To-day we may insolently disregard the settled convictions of the people, by gross perversions of the charter of their liberties; to-morrow the dangerous precedents may be urged to our own ruin. The inventor of the guillotine, we are told, was soon forced to test the merits of his own invention, and Haman, by sudden change of fortune, met the fate he had prepared for the offending Jew.

"Pass this bill, by which the owner is stripped of his real and personal property wherever your armies march, then enact the measure proposed by the able and excellent Senator from New York (Mr. Harris), by which he is outlawed and driven from the courts of the land, and I have no promises to make in regard to future exhibitions of loyal sentiment in the Southern States. Let Congress adopt the course pursued by that practical statesman and distinguished soldier who commands the department of the Mississippi, pledging the power of the Government to the protection of life, liberty, and property, and our battles like his will be victories—victories beneficial alike to the victor and the vanquished, removing prejudice, reforming sentiment, and regenerating the public mind."

Mr. Harris, of New York, offered a substitute to the bill, and expressed his views in these words: "Ours should not be a revengeful policy. On the contrary, by adopting measures of mildness and mercy, our effort should be to extinguish the fires of hate which now burn so fiercely. Exile and the gallows for leaders. Confiscation and outlawry for those who have, with 'malice aforethought,' conceived and planned and brought into hideous maturity this monstrous iniquity; but pity and pardon for their deluded followers—those whose greatest crime has been that they have loved the bones of their fathers more than they loved their country, who have from their childhood been educated in the heresy that their first and highest allegiance is due to their State, even if it requires them to take up arms against the Union. Such, in my judgment, is an outline of the policy which a great, magnanimous, and Christian people should adopt in dealing with conquered treason."

Mr. Howard, of Michigan, thus argued that Congress had the power to enact such a law: "I come now to the question of power, the great question whether under our written Constitution we as a Government have in law the right to declare and enforce the forfeitures and confiscations contemplated by the bill.

"I admit that if we have not this power under the Constitution, we cannot forfeit and confiscate the property of rebels, real or personal, and that any title we might assume to give would be void in law.

"There is no clause in the instrument expressly conferring the power, and unless it is implied as a means of carrying into execution some one of the powers expressly granted and

enumerated, or some other power not so expressed and enumerated, but nevertheless 'vested (to use the terms of the instrument) by this Constitution in the Government of the United States, or in any department thereof,' we are unable to exercise it. I need not say to candid and reflecting men that the dangers arising from too broad an interpretation of the Constitution are by no means less to be dreaded and avoided than those proceeding from one too narrow and illiberal. The instrument must be construed with reference to the state of things existing at its formation, and the purposes had in view by its framers. Those purposes are plainly announced in the comprehensive language of the preamble, and no one can misunderstand them. They were 'to form a more perfect union, establish justice, insure domestic tranquillity, provide for the common defence, promote the general welfare, and secure the blessings of liberty to ourselves and our posterity.' The insuring of domestic tranquillity is thus expressly indicated as one of the prominent objects of the Constitution, and nothing can be plainer than that it means, not mere family or neighborhood tranquillity, not the tranquillity of the fireside, but the internal tranquillity of the nation as a nation, and of the States as political bodies and constituent parts of the nation. It was political tranquillity, as opposed to political disturbance, as opposed to anarchical and insurrectionary movements of classes, districts, or communities, tending to disturb the internal peace of the nation, and to overthrow law and order.

"Such is one of the ends for which the Constitution was made—an important end; one without which the Government itself would have been but vanity and vexation of spirit, and the liberties it was to secure a chimera."

Mr. Davis, of Kentucky, in opposition to the bill, said: "It will be observed from the reading of the bill that it creates two classes of persons whose property shall be forfeited. One class is composed of those who are out of the United States, or who are within the States now in rebellion, and in such position that the ordinary process of the courts cannot be served upon them. It then provides by different modes of proceeding for all that class of persons in arms in the rebellion, or giving it aid and comfort, who can be found within the loyal States, or in such position in the United States that the ordinary process of law can be served upon them. The white population of the disloyal States amounts to 5,450,831. The slaves in the same States amount to a fraction above the number of 3,500,000. By the last census, there are 3,953,587 slaves in the United States. There are 3,500,000 in the disloyal States—in the States that have seceded—and about 450,000 in the States that are yet loyal, including the western portion of the State of Virginia. I assume that there are as many disloyal men in the loyal States as there are loyal men in the seceding States; and I have no doubt that the

number of disloyal men in the loyal States is larger than the number of the Union men in the seceding States. The result, then, is, that the bill takes from a number of white people equivalent to the entire white population of the loyal Slave States a slave population equivalent to the entire slave population of the disloyal States. It not only takes their slave property, but it takes all the property that they own. What is the aggregate amount of the property of the disloyal States, according to the census tables? It is \$6,792,585,742 in amount. The property of the loyal Slave States amounts to \$1,983,702,055; so that the aggregate amount of property in the Southern States that is subject to be acted upon by the provisions of this bill, if it becomes a law, will affect upward of six millions of people, and will deprive them of property of the value of \$4,808,883,687—nearly five thousand millions of dollars. Now, sir, I ask if this measure in its proportions is not as gigantic as the insurrection and the war itself? Was there ever in any country that God's sun ever beamed upon a legislative measure involving such an amount of property, and such numbers of property holders?

"I will take another view of this subject. The surplus production of the States that have seceded, amounts annually to between five hundred and six hundred millions of dollars. Of this large surplus, at least one hundred and fifty millions are distributed to the loyal and Free States for cereal grains, for meats, for stock, for mules, horses, and manufactured articles of various kinds. My own State of Kentucky finds a market annually in the Southern States, growing out of the productions of their slave labor, to the amount of eight or ten millions of dollars, and the Free States in the same market find a sale for their articles of natural or artificial productions to the amount of at least one hundred and fifty millions of dollars. Look at the great grain-growing regions of the West, the Egypt of America in fertility and production. Where do they find their principal markets for their corn and their meats? Where do Indiana, Missouri, Ohio, Kentucky, and every other portion of the United States that produces and sells stock find a market for their stock? They find it in the same sunny South, producing cotton and sugar. Where do Chicago, Cincinnati, and the other manufacturing points of plows, agricultural implements, and all the machinery by which crops are produced and harvested, find their market for the sale of their manufactured articles? It is in the South. Where does New England, where does Massachusetts, find the principal market for her boots and her shoes, her coarse woollens, her coarse cottons, and her ice even? It is in the South.

"I intend to maintain and shall endeavor to show that this great and enriching market for the loyal and Free States will be cut off by this iniquitous measure—for I so denominate it—if it should become a law. The great devotees

to labor and industrial pursuits in the field of agriculture, and in the workshops, who find their markets and the rewards of their toil and of their labor and of their skill in the South, will rise up in earnest protest against any such measure as this. Their voice will be heard before long in this chamber. It will be heard resounding throughout this nation; and it will be heard in a majesty and strength that will command obedience to it, and it will repress and put down such wholesale measures of confiscation, of injustice, of oppression, and iniquity."

Mr. Collamer, of Vermont, followed in opposition to the bill in its present form, saying: "I come now, Mr. President, to talk more particularly in relation to another branch of this bill, which is not so obvious perhaps. It seems to me that there is another purpose that is covered up by this pretence of forfeiture or confiscation and proceedings *in rem*, which have really nothing to do with it. When we are communing together, and talking freely, we may as well tell the truth as not. I cannot exactly recommend my example in that respect, as the old gentleman did who told his sons that honesty was the best policy, 'because,' says he, 'I have tried it both ways.' Now, the truth is, that there is a large provision in this bill for the liberation of slaves, and I am strongly apprehensive that the more particular friends of this bill regard that as the bill. Without that, they would care nothing about it. Many of them, I have no doubt, are exactly in that condition. Are you going to have these slaves seized as prize of war? There is no provision of that kind, because you know that what you declare prize of war must be seized during the war; and if it is not, when the peace comes it escapes, and you cannot take it at all. No; this provision is made to declare all slaves free without ever taking them. There is no caption of them required. They are not declared prize of war, or required to be proceeded with as such. How is it, then? They are regarded as property. I do not mean to fall into any objectionable point on that. I do not believe in having property in man any more than anybody else; but certain it is that the master, as he is called, is acknowledged by the Constitution to have an interest in the labor and service of his slave. There is an acknowledged pecuniary interest there recognized. It is a pecuniary interest. You propose to get rid of that interest, clear it out, discharge it. Can you do that by a proceeding *in rem*? I know we made a law at the last session declaring that where slaves were made the instruments of wrong by using them for military purposes in aid of the rebellion, they should be free, and that falls within the doctrine, within the principle, I have stated. But nothing of that kind is here. It was not put here purposely, because a proceeding *in rem* implies that you have possession of the thing, and brought it into court to be adjudicated upon. It is not provided that these slaves are to be

taken or brought into any court, or in any way adjudicated upon. There is not any proceeding *in rem* required upon them, nor any other proceeding. If that is not depriving a man of his interest in a slave without any conviction of himself, and without any process of law, and operating as a punishment on him, and yet leaving him to be hanged, I do not understand it. It seems to me to be all that, every particle of it.

"Again, Mr. President, we have individually, and the Republican party as a party, thrown our creed and articles of political faith before the world. We have subscribed to them, most of us personally, individually at different stages, and I believe it is not necessary for me to make any personal professions about that. I am still very much inclined to abide by a pledged public faith, and by private faith too. I cannot but observe that those gentlemen who certainly have been distinguished as much or more for their activity in relation to the subject of slavery as for anything else, are committed to the creed of the Republican party on this point. Take, for instance, the honorable Senator from Massachusetts (Mr. Sumner). I will read his words. On offering a certain memorial, on the 25th of February, 1861, he said:

I offer this memorial, sir, because I deem it my duty to offer all memorials that are respectful in form, when sent to me; but in offering it, I take this occasion to declare, most explicitly, that I do not think that Congress has any right to interfere with slavery in a State.

"I do not know that the gentleman has ever spoken in any other way."

Mr. Sumner: "Never."

Mr. Collamer: "I have never heard him speak otherwise, and I have generally heard what he had to say. I have been glad to find that this somewhat early and uniform doctrine of our party had not become outlawed by war, and hence I was pleased to hear some Senators who sit near me, and whom I always hear with very great pleasure and respect, make use of the expressions which I am about to read. I will use their language as better expressing the idea than any language I could employ. The honorable Senator from Maine (Mr. Fessenden), in the course of the debate upon the bill for the abolition of slavery in this District, said:

Mr. President, that the Republican party would rejoice to see slavery abolished everywhere, that they would rejoice if it no longer existed, that they feel it to be a blot upon our fair institutions, and a curse to the country, there is no doubt. I can answer, for one, that has been my opinion always, and I have expressed it here and elsewhere; but, sir, I have held, and I hold to-day, and I say to-day, what I have said in my place before, that the Congress of the United States, or the people of the United States through the Congress, under the Constitution as it exists now, have no right whatever to touch, by legislation, the institution of slavery in the States where it exists by law. I have said that, and I say it again, boldly; for my position never has been misunderstood on this subject.

"The honorable Senator from Ohio (Mr. Sherman), on the same occasion, said:

We ought now to abolish slavery in this District.

We have the right, and it is our duty to do it; and if we had wasted less time in doing it, it would probably be just as well. We ought, then, religiously to adhere to the promises we made to the people of this country when Mr. Lincoln was elected President. We ought religiously to abstain from all interference with the domestic institutions of the Slave or the Free States. We ought to stand by the Constitution as it is, by the Union as it is. Whether rebels are in arms or not, our duty is to stand by our pledges, to stand by our manhood; and I, for one, will do it.

"If we make a law, intending it to be operative, by which we declare that the slaves of all engaged in this rebellion, or of all the officers and classes mentioned in the amendment of the Senator from Ohio are free, and all right over them abolished, do you believe, does any man of common sense believe, that you can make the world understand that we have not interfered with slavery in the States, and not to a very limited extent either, but to about the whole extent to which it exists? All remarks, however ingenious, and all sophistry, however plausible, which can make this look any otherwise, is but a delusion. It cannot be seen in any other light. This is not put on the ground that it is a military operation, not on the ground of proceedings *in rem*, not that it deprives a man of his property and yet leaves him to be hung, not upon any conviction, not upon any process of law whatever, except this law which we now make.

"It seems to me, obtuse as I am, perhaps, in my perceptions, that that is directly interfering with this plighted faith; and it seems to me, further, that it is in direct violation of the provisions, prohibitions, and securities which the Constitution enacts. I, for one, will not do it. I do not regard myself as needing any apology for not doing it. I do not think my people wish me to contribute to breaking any provision of the Constitution, and they know I would not do it if they did wish it; nor do they need any apologies from me for regarding the oath I have taken."

Mr. Collamer then submitted an amendment, or bill of his own, which with several other amendments were referred to a select committee of nine Senators.

The following committee was afterward appointed: Mr. Clark chairman, Mr. Collamer, Mr. Harlan, Mr. Cowan, Mr. Wilson of Massachusetts, Mr. Harris, Mr. Sherman, Mr. Henderson, and Mr. Willey.

This committee subsequently reported a bill, the first section of which provided that every person who should hereafter commit the crime of treason against the United States and be adjudged guilty thereof, should suffer death, and all his slaves, if any, be declared and made free, or he should be imprisoned not less than five years, and fined not less than ten thousand dollars and all his slaves, if any, be declared and made free.

Mr. Clark, of New Hampshire, said: "The desire of the committee was to harmonize the various shades of opinion and the various plans,

and to present something to the Senate which they thought might be passed.

Mr. Trumbull, of Illinois, moved to strike out the first section of the bill. He said: "If any unconstitutional bill has been offered to the Senate, this bill in its first section is unconstitutional. Beyond that, the section is a provision simply to make treason easy. It is a provision to lighten the punishment for treason. I doubt whether this is the best time to do that. Our fathers prescribed the penalty for treason. They regarded it as the most atrocious crime that man could commit."

Mr. Clark, of New Hampshire, replied: "I expected an assault to be made upon the bill by those who wanted to take property without any trial. I did not suppose a trial would suit such persons; it is not quick enough. But I hope, notwithstanding, the Senate will not consent to strike out this section. By the old law, the punishment of treason was death, and is death by the law now. In the circumstances of this rebellion, where there is a great variety of shades of guilt, where there is the man who leads on and incites the rebellion, and the man who is drawn into it, the committee thought there should be a difference in punishment; that in some cases death would not be too severe, and in other cases death would be too severe, where some punishment should be inflicted. If the law should be permitted to stand as it now stands, if you try a person for treason he must be executed unless pardoned. You cannot imprison him; you cannot fine him; but you must take his life, or pardon him. We desired to give discretion to the court."

Mr. Davis, of Kentucky, moved to amend by striking out the words "and all his slaves, if any, shall be declared and made free."

Mr. Clark, of New Hampshire, said: "I want to inquire of the Senator why, when he has taken away the life for treason, or when he has incarcerated the body and shaved the head and made the man sit in sackcloth, he objects to taking away his negro also? Take his life, or shave his head, put manacles on him, set him down in sackcloth and ashes, but do not touch his negro!"

Mr. Davis: "I have no objection to taking his negro, or any property whatever, if you just confiscate it *bona fide*. The Congress of the United States have no power to liberate a slave in a State, or to authorize it to be done. I have no objection to slaves being treated like lands, or any other property. I think myself they ought to be subjected to the same law and to the same course of appropriation that other property is. I do not think there ought to be any distinction. The reason that I do not give in to the view of the gentleman is, that I believe it is not competent for Congress to liberate or to authorize the liberation of a negro anywhere, and particularly in the States."

Mr. Clark: "Let the Senator give me his attention a moment, and I think he will agree with me that it is not competent for Congress

to go into the State of Virginia or Kentucky and pass a law taking away \$10,000 of property from a man; but it can impose a punishment that shall take it from him. It may not be competent directly to take the slave from him, but it can impose a punishment which shall take it from him. I have not any doubt about it, and that is what this bill seeks to do."

Mr. Davis: "Will the gentleman permit me to answer that?"

Mr. Clark: "Certainly."

Mr. Davis: "I admit that Congress may authorize the punishment of treason, and I admit that it may authorize the punishment of treason prospectively by a forfeiture of property for the lifetime of the criminal; but I deny that to take property and not appropriate the proceeds to the public treasury is a forfeiture at all. Every definition of confiscation and forfeiture is to this effect, that a party charged with the commission of a crime or some legal default of duty, loses his interest and estate in the property, and the property is transferred to the nation or to individuals to remunerate them for the real or supposed loss by the default of the person who is charged with the default. That is forfeiture or confiscation."

Mr. Clark: "Then as I understand it, the objection is not that we take the negro from the master by way of punishment, but that we do not give him to somebody else, or put him into the public treasury."

Mr. Davis: "Yes, sir; that is the objection; that you do not sell the negro, do not appropriate the negro as you would other property."

Mr. Clark: "Now, I want to submit this question to my honorable friend: suppose we had forfeited a horse or a mule, could we not turn it free?"

Mr. Davis: "I think not."

Mr. Clark: "Could we not turn a horse loose if he was expensive to keep?"

Mr. Davis: "You might refuse to appropriate him, but your duty and the execution of the idea of forfeiture would require you to appropriate that property, to sell that property, and put the proceeds into the public treasury."

Mr. Clark: "Very well. Suppose Congress thought that its duty required him to go free: what then? Who is to judge of the duty?"

Mr. Davis: "I will answer that, with the gentleman's permission. The term 'forfeiture' is a legal phrase. It is a term of art. It has as precise a legal significance, and had at the time of the adoption of the Constitution, as the term '*ex post facto*,' or the term 'bill of attainder,' or any other technical legal term of art. My position is that the term 'forfeiture' necessarily imports, as the principal and essential idea, that the property is to be disposed of for the benefit of the party that is injured in fact, or supposed to be injured, whether that party be the United States or individuals. I ask the Senator from New Hampshire to bring me a definition of confiscation or forfeiture, or a

decision of a court where the proceeds of the property confiscated or forfeited were not appropriated. Give me a single example. I say that the essence of forfeiture, the main idea of forfeiture, is not so much to deprive the person in default and charged with crime of property as it is to transfer that property to the public or to individuals who are supposed to be injured by the act of the criminal."

Mr. Clark: "Will the honorable Senator permit me to ask him if he has read this section?"

Mr. Davis: "Yes, I have."

Mr. Clark: "Is the word 'forfeiture' in it?"

Mr. Davis: "Certainly not."

Mr. Clark: "Then I do not understand the necessity of a definition of forfeiture. It simply provides that his slaves shall go free. Suppose it provided that he should stand in the pillory?"

Mr. Davis: "If you were to present a rose and were not to name it, would it not be a rose still? I suppose that a thing is a thing, whether you give it a designation or not. I was very much impressed with the objections of the Senator from Illinois, but I do not propose to go into that question. I plant myself upon this ground: that Congress has no power to emancipate a slave under the pretence of forfeiture or of punishing a traitor, or under any other pretence whatever; that the act of emancipating a slave in a State is not within the powers of Congress."

Mr. Clark: "There the Senator and I entirely disagree. He says Congress has no power to do it. I assert the power of Congress to do it; but this section does not attempt to forfeit a slave. It sets him free. It declares, as a punishment of the master's offence, that the slave shall go free, and that the owner shall not hold him. That, I think, we have a right to do."

Mr. Davis: "I think not."

The motions to amend and strike out were both lost.

Mr. Sumner, of Massachusetts, offered a substitute to the bill, which he sustained in a speech of much length, and concluded by saying relative to the liberation of slaves, thus:

"The slaves of rebels cannot be regarded as property, real or personal. Though claimed as property of their masters, and though too often recognized as such by individuals in the Government, it is the glory of our Constitution that it treats slaves always as 'persons.' At home, beneath the lash and local laws, they may be chattels; but they are known to our Constitution only as men. In this simple and indisputable fact there is a distinction, clear as justice itself, between the pretended property in slaves and all other property, real or personal. Being men, they are bound to allegiance and entitled to reciprocal protection. It only remains that a proper appeal should be made to their natural and instinctive loyalty; nor can any pretended property of their masters supersede

this claim, I will not say of eminent domain, but of eminent power, inherent in the national Government, which at all times has a right to the services of all. In declaring the slaves free, you will at once do more than in any other way, whether to conquer, to pacify, to punish, or to bless. You will take from the rebellion its mainspring of activity and strength; you will stop its chief source of provisions and supplies; you will remove a motive and temptation to prolonged resistance, and you will destroy forever that disturbing influence which, so long as it is allowed to exist, will keep this land a volcano ever ready to break forth anew. But while accomplishing this work, you will at the same time do an act of wise economy, giving new value to all the lands of slavery, and opening untold springs of wealth; and you will also do an act of justice destined to raise our national name more than any triumph of war or any skill in peace. God, in His beneficence, offers to nations as to individuals, opportunity, *opportunity*, OPPORTUNITY, which, of all things, is most to be desired. Never before in history has He offered such as is now ours. Do not fail to seize it. The blow with which we smite an accursed rebellion will at the same time enrich and bless; nor is there any prosperity or happiness which it will not scatter abundantly throughout the land. And such an act will be an epoch marking the change from barbarism to civilization. By the old rights of war, still prevalent in Africa, freemen were made slaves; but by the rights of war which I ask you to declare, slaves will be made freemen."

Mr. Davis, of Kentucky, offered the following amendment:

*Provided*, That all the property owned by any person convicted of any crime under this act shall be first subject to the payment of all his debts and liabilities due and subsisting at the time thereof to loyal creditors.

This was rejected—yeas 12, nays 26. Mr. Powell, of Kentucky, moved to strike out the following section:

SEC. 11. *And be it further enacted*, That the President of the United States is authorized to employ as many persons of African descent as he may deem necessary and proper for the suppression of this rebellion, and for this purpose he may organize and use them in such manner as he may judge best for the public welfare.

The question, being taken by yeas and nays resulted—yeas 11, nays 25; as follows:

YEAS.—Messrs. Carlile, Davis, Henderson, Latham, Pearce, Powell, Saulsbury, Stark, Willey, Wilson of Missouri, and Wright—11.

NAYS.—Messrs. Anthony, Browning, Clark, Collamer, Cowan, Dixon, Doolittle, Fessenden, Foot, Foster, Grimes, Harlan, Harris, Howard, Howe, Lane of Kansas, Pomeroy, Sherman, Sumner, Ten Eyck, Trumbull, Wade, Wilkinson, Wilmot, and Wilson of Massachusetts—25.

Mr. Henderson, of Missouri, offered the following amendment:

That every person who shall hereafter commit the crime of treason against the United States, as defined by the first section of the act of April 30, 1790, and shall be convicted on confession in open court, or on

the testimony of two witnesses to the same overt act of treason whereof he shall stand indicted, such person shall suffer death, or be punished by imprisonment, with or without hard labor, not less than five years; and all judgments on convictions of treason under this act shall have the effect to forfeit to the United States all the property, real and personal, rights, credits, and effects of the party so convicted for and during his natural life.

The yeas and nays were ordered; and being taken, resulted—yeas 12, nays 25; as follows:

YEAS.—Messrs. Carlile, Cowan, Davis, Henderson, Latham, Powell, Saulsbury, Sherman, Stark, Willey, Wilson of Missouri, and Wright—12.

NAYS.—Messrs. Anthony, Browning, Chandler, Clark, Collamer, Dixon, Doolittle, Fessenden, Foot, Foster, Grimes, Harlan, Harris, Howard, Howe, King, Lane of Kansas, Pomeroy, Sumner, Ten Eyck, Trumbull, Wade, Wilkinson, Wilmot, and Wilson of Massachusetts—25.

Mr. Davis, of Kentucky, offered the following amendment:

*Provided*, That no slave shall be emancipated under this act until such slave shall be taken into the possession of some agent of the United States, and be *in transitu* to be colonized without the United States of America.

The yeas and nays were ordered; and being taken, resulted—yeas 6, nays 30; as follows:

YEAS.—Messrs. Davis, Powell, Saulsbury, Stark, Wilson of Missouri, and Wright—6.

NAYS.—Messrs. Anthony, Browning, Chandler, Clark, Collamer, Cowan, Dixon, Doolittle, Fessenden, Foot, Foster, Grimes, Harlan, Harris, Henderson, Howard, Howe, King, Lane of Kansas, Latham, Pomeroy, Sherman, Sumner, Ten Eyck, Trumbull, Wade, Wilkinson, Willey, Wilmot, Wilson of Massachusetts—30.

Mr. Saulsbury, of Delaware, moved to strike out the following section:

SEC. 9. *And be it further enacted*, That at any time after the passage of this act, whenever the President of the United States shall deem it necessary for the suppression of this rebellion, he shall issue his proclamation commanding all persons immediately to lay down their arms and to return to their allegiance to the United States; proclaiming that if any person within any State or district declared by him in a state of insurrection, shall be found in arms against the Government of the United States thirty days after the date of such proclamation, or giving aid and comfort to the present rebellion, the slaves of all such persons, within such State or district, shall be made free, and thereupon the slaves of all such persons, at the expiration of said thirty days, shall be free and forever discharged from any and all claim to their labor or service, any law or custom of any State notwithstanding.

Mr. Saulsbury said: "The only intention of the section, as a whole, is to attempt to confer on the President a power which this Congress cannot confer on him, and that is to liberate slaves in the States by proclamation. If any benefit could result to the country from any such proceeding, certainly some benefit would have been experienced heretofore, for we have had two or three generals attempting that game."

Mr. Trumbull, of Illinois, followed in favor of a still stronger section, saying: "I shall vote with the Senator from Delaware to strike out this ninth section; and I hope that all the friends of a really efficient measure will vote with me. Let us strike it out, and put in a

section that will be effective. Let us strike out this section, and then afterward we can supply its place with a section making it the duty of the President to issue this proclamation, if you propose to give the thirty days' notice. I would free the slaves of all who shall continue in arms after the passage of the act. That would be my proposition; and I cannot conceive how it is, when these men are with arms in their hands, as the Senator from New Hampshire said, shooting our brothers and our sons, that we can insist upon holding their negroes in their possession to enable them to shoot our sons and our brothers. I think we ought to make that section imperative."

Mr. Cowan, of Pennsylvania, objected to the bill on grounds of expediency: "I suppose there is no gentleman upon this floor who is not now of opinion that the President may, if he chooses, under the pressure of a military necessity, make such proclamation as is contemplated in this section; and I suppose further that there is no one here who believes that under any circumstances other than a pressing necessity he would order and direct such a proclamation to be made.

"I may say further, Mr. President, that I am exceedingly sorry that at this stage of the business we seem to be tending toward a rock upon which, in my opinion, we shall inevitably and fatally split, and that very soon, for I think if there is one truth well established in the world it is that our guide in constitutional legislation is the will of the people—I mean of the majority. What are we doing here to-day? Laws are proposed, the operation of which is to be confined to the Slave States. A number of those States are represented in this Chamber by loyal men, men of approved loyalty and patriotism. What are they here for? They are here to let us know what the will of the people is in those States where these laws are to operate.

"Now, Mr. President, it is not a question whether the opinions and beliefs of that people are in accordance with our views. Suppose them to be erroneous opinions and erroneous beliefs, and having for their end, aim, object, and purpose to sustain a mischievous and dangerous system, yet, sir, we cannot disguise the fact that they do exist there, and for my own part, I cannot relieve myself from the obligation to respect them. How is it in the North? We of the majority forget here that we do not represent the whole people of the North. We do not represent the opinions and the beliefs of all the people of the Free States upon this subject. We forget that there is another and a powerful party all through the North everywhere who are utterly and totally hostile, if we are to be allowed to take the ordinary indications of public opinion, to this system of legislation, this system of congressional emancipation and liberation, no matter under what shape or form you disguise it. Well, how are we to maintain ourselves with one half of the people

of the Free States against it; and I think the gentlemen who represent the border States will say to us that their people are unanimously opposed to it. Under these circumstances, it does not matter to me a particle what my opinions may be, what my belief may be. We are here to legislate for the people. We are here, in the first place, to stand upon the Constitution, because the Constitution is paramount, and no matter what the will of the people might be, if the will of the whole people were in favor of any particular project which is unconstitutional, it is our duty to throw out that project and discard it; but where the legislation is constitutional, and within the purview of that instrument, then our next guide is the will of the people. Now, I ask Senators who come from the Free States, do you believe, do you suppose that you can get along here and suppress this rebellion by disregarding what these gentlemen from the border States tell us?"

Mr. Wilson, of Massachusetts: "We have so far."

Mr. Cowan: "The Senator from Massachusetts says we have so far; and where are we now; how far have we got? We have gotten so far that oftentimes the heart of the patriot despairs. And do we strengthen ourselves by violating the opinions and the beliefs and feelings of these men? Are we making them friends? I think it is exceedingly unkind to the representatives from those States here. What right have we to drive away from the Senators from Virginia the friends who have stood about them in these dark hours? What right have we to do the same with the Senators from Missouri, or the Senators from any border State? Is that proper treatment? I would defer to those gentlemen as to all things relating to their own States, and as to all laws which are to operate on their own people. Upon what presumption do we decide that they are not interested in putting down this rebellion—ay, even more than we are? I should like to know from the honorable Senator from Massachusetts how he comes to know better than they do how to put down this rebellion."

Mr. Wilson, of Massachusetts, replied: "I take it that some of us have studied this question quite as long as the Senator from Pennsylvania, or gentlemen of the border States; that we have looked into it quite as minutely, and that we have a right to our opinions. I see no reason why I should give up my opinions to those of any gentleman from the border States. I do not know anything in the history of this contest, from the time it opened in the attack on Fort Sumter up to this time, in the advice we have received from gentlemen of the border States, whether we have followed it or not, that entitles their opinions to any more weight than the advice received from any other portion of the country. I think the history of this war shows that if we have failed anywhere, it has been because too much deference has been paid by the Government, and by Congress, to



those opinions. As we look back over the history of the past, we see it. It marks every furlong of this contest. Our own feebleness of purpose, our own deference to fears and anxieties, have prolonged the contest, and have cost us hundreds of millions of dollars, and thousands of lives. That is my judgment."

A contest, as indicated in the preceding remarks, had arisen in the Senate upon the bill reported by the committee. Some Senators wanted a more stringent bill, whilst others were satisfied with the report.

Mr. Sumner, of Massachusetts, one of those who desired a more stringent measure, spoke of the report thus: "Mr. President, there is a character in one of Dickens's novels, who says to another, 'Take a glass of water, put into it a little piece of orange peel, and then make believe very hard and you will have a strong drink.' Now, sir, I would apply these words to the bill of the committee. It is like a glass of water with a bit of orange peel in it, and if you make believe very hard you may have a strong bill. To my mind, it amounts to nothing. It only plays with the subject. At a moment when the life of our Republic is struck at, Senators propose to proceed as if by an indictment in a criminal court. I have, therefore, no sympathy with the bill. It is inadequate to the occasion. It is a perfect nonentity. And yet, sir, I took part in raising the committee which has reported the bill. I remember well that my friend from Ohio (Mr. Wade) said, when we were considering whether that committee should be raised, that confiscation would be lost by it, and I replied to him at once that he was mistaken, that confiscation would be saved by it. Such was my opinion."

Mr. Collamer, of Vermont, was brought to his feet by this speech. He said: "I have been perfectly silent upon this particular bill, willing that the subject should be treated by all men in their own way, according to their own tastes; but when I am appealed to by name, personally, I suppose I am not at liberty to sit still. Common courtesy to the honorable Senator will not admit it, though he thinks that I am one of a committee that helped to concoct a measure like putting a piece of orange peel into a tumbler of water, for the purpose of deceiving and duping Senators: addressing myself to their faith to make them believe there was great virtue in it, when I knew there was nothing in it—a sort of bread pill. He accuses me of that, and calls that courtesy."

Mr. Sumner replied: "The Senator misunderstands me when he says I attribute any such motive to him."

Mr. Collamer thus described the course taken in the debate: "At almost every step in the consideration of this subject, Senators have indulged in terms of reproach to those who differ with them in opinion—terms of contumely—terms which impute to them all sorts of bad motives; more than intimating that they are leagued with the enemies of the country to get

votes, and that that is their purpose. Now, sir, I am aware that the history of the world is full of that sort of spirit. I have long experienced it here. It has sometimes been called the crack of the plantation whip. No matter in whose hands it is wielded, the music of that whip is the same, the sound is the same, and the effect is the same. It is totally immaterial whether that spirit is indulged in relation to one subject or another. Whether, by the bigotry of religious sentiment, it sends a man to the *auto da fe*, or whether it sends a man to the guillotine under political excitement, it is all the same the world over."

The discussion became somewhat of a personal nature, and was continued at considerable length between the Senators of extreme and those of conservative views.

Meantime the subject had been taken up in the House of Representatives, and extensively debated, with nearly similar arguments to those advanced in the Senate. Mr. Thomas, of Massachusetts, among other speakers, in opposition to the bill, thus spoke: "Mr. Speaker, no man can desire more earnestly than I do the suppression of this rebellion, and the restoration of order, unity, and peace. But there are two things I cannot, I will not do. I will not trample beneath my feet the Constitution I have sworn before God to support. I will not violate even against these rebels the law of nations as recognized and upheld by all civilized and Christian states. I believe I must do both, to vote for these bills, and at the same time do an act unwise and especially adapted to defeat the end in view, if that end be the restoration of the Union and the salvation of the Republic.

"I propose very briefly to examine the bills before the House (and especially that as to confiscation of property) under the law of nations and under the Constitution of the United States, and then to say a word upon their policy.

"The positions assumed by the friends of these measures are, that we may deal with those engaged in this rebellion as public enemies and as traitors; that regarding them as enemies, we may use against them all the powers granted by the law of nations; and viewing them as rebels or traitors, we may use against them all the powers granted by the Constitution; and that in either view, these bills can be sustained.

"Dealing with them as public enemies, it is said that under the existing law of nations we have a clear right to confiscate the entire property on the land as well as the sea, real and personal, of those in arms, and of non-combatants who may in any way give aid and comfort to the rebellion. This first bill sweeps over the whole ground. I deny the proposition, Mr. Speaker. In the name of that public law whose every humane sentiment it violates; in the name of that civilization whose amenities it forgets and whose progress it overlooks; in the name of human nature itself, whose better in-

stincts it outrages, I deny it. Such is not the law of nations.

"To give a plausible aspect to the proposition, the advocates of this bill have gone back to Grotius and to Bynkershoek for the rules of war, and even then have omitted to give what Grotius calls the *temperamenta*, or restraints upon the rules. You might as well attempt to substitute the code of Moses for the beatitudes of the gospel. Anything can be established by such resort to the authorities.

"But what then, Mr. Speaker? Does any man suppose that these writers give us the laws of war as upheld, sanctioned, and used by the Christian and civilized states of to-day? Nothing would be further from the fact. Commerce, civilization, Christian culture, have tempered and softened the rigor of the ancient rules; and the state which should to-day assume to put them in practice would be an outcast from the society of nations. Nay, more, they would combine, and rightfully combine, to stay its hand. For the modern law of war, you must look to the usages of civilized states, and to the publicists who have explained and enforced them. Those usages constitute themselves the laws of war.

"In relation to the capture and confiscation of private property on the land, I venture to say, with great confidence, and after careful examination, that the result of the whole matter has never been better stated than by our own great publicist, Mr. Wheaton:

But by the modern usages of nations, which has now acquired the force of law, temples of religion, public edifices devoted to civil purposes only, monuments of art, and repositories of science, are exempted from the general operations of war. Private property on land is also exempt from confiscation, with the exception of such as may become booty in special cases, when taken from enemies in the field or in besieged towns, and of military contributions levied upon the inhabitants of the hostile territory. This exemption extends even to the case of an absolute and unqualified conquest of the enemy's country.—*Elements of International Law*, p. 421.

"It is not too much to say that no careful student of international law will deny that this passage from Mr. Wheaton fairly expresses the modern usage and law upon the subject; but you will permit me to refer for a moment to the doctrine stated by my illustrious predecessor, whose name has been so often invoked in this debate, John Quincy Adams. 'Our object,' he says, in a letter to the Secretary of State, 'is the restoration of all the property, including slaves, which, by the usages of war among civilized nations, ought not to have been taken.' 'All private property on shore was of that description. It was entitled by the laws of war to exemption from capture.' (Mr. Adams to the Secretary of State, August 22, 1815.)

"Again, he says, in a letter to Lord Castlereagh, February 17, 1816:

But as by the same usages of civilized nations private property is not the subject of lawful capture in war upon the land, it is perfectly clear that in every stipu-

lation private property shall be respected, or that upon the restoration of places during the war, it shall not be carried away.—*4 American State Papers*, pp. 116, 117, 122, 123.

"A volume might be filled with like citations from modern writers. I will content myself with perhaps the latest expression, and from a great statesman, a native of Massachusetts, and of my own county of Worcester:

The prevalence of Christianity and the progress of civilization have greatly mitigated the severity of the ancient mode of prosecuting hostilities. \* \* \* It is a generally received rule of modern warfare, so far at least as operations upon land are concerned, that the persons and effects of non-combatants are to be respected. The wanton pillage or uncompensated appropriation of individual property by an army even in possession of an enemy's country, is against the usage of modern times. Such a proceeding at this day would be condemned by the enlightened judgment of the world, unless warranted by particular circumstances. Every consideration which upholds this conduct in regard to a war on land favors the application of the same rule to the persons and property of citizens of the belligerents found upon the ocean.—*Mr. Marcy to the Count de Sartiges*, July 28, 1856.

"Such I believe to be the settled law and usage of nations. A careful examination of the arguments made on this subject has served but to strengthen and deepen this conviction.

"I do not forget, Mr. Speaker, that the case of *Brown vs. The United States* (8 Cranch, 110), has been often referred to in this debate as affirming the contrary rule. The points decided in that case I have before stated to the House. The points, the only points, decided were that British property found in the United States on land, at the commencement of hostilities (war of 1812), could not be condemned as enemy's property without an act of Congress for that purpose, and that the declaration of war was not sufficient. Gentlemen have referred to the *obiter dicta*, the discussions of the judges, as the decision of the court. The distinction is familiar and vital, but has been lost sight of in this debate. Only the points necessarily involved in the result constitute the decision.

"But I return from this digression to say, Mr. Speaker, that the distinction sought to be established by the passages cited from the discussions, in the case of *Brown vs. The United States*, between the law of war and the mitigations of that law which the usages of modern nations have introduced, has no foundation in principle. It is in the usages of civilized and Christian nations that we are to seek the law of nations. As the law merchant has grown up from the usages of trade and commerce, so has the modern law of nations grown up from the usages of enlightened states. The ancient barbarous rules of war have been tempered and softened by commerce, by the arts, by diffused culture, and, more than all, by the spirit of the gospel; and all Christian states recognize with joy and with obedience the milder law. In the jurisprudence of nations, as in our own, there is one law felt above all others, the law of progress. Apparently at rest, it is ever si-

lently moving onward, quickened, purified, and illumined by the inspiration of that higher law, 'whose seat is the bosom of God, and its voice the harmony of the world.' The great, prophetic thought of Pascal may yet be realized—*'Deux lois suffisent pour régler la république chrétienne, mieux que toutes les lois politiques: l'amour de Dieu, et celui du prochain.'*

"I do not know that I can more fitly conclude what I can say, in the brief time allotted to me, on the capture and confiscation of the private property of rebels, viewed in the light of international law, than in the words of John Marshall, near the close of his judicial life:

It may not be unworthy of remark that it is very unusual, even in cases of conquest, for the conqueror to do more than to displace the sovereign and assume dominion over the country. The modern usage of nations, which has become law—

mark the words, Mr. Speaker, 'the modern usage of nations, which has become law'—

would be violated; that sense of justice and of right which is acknowledged and felt by the whole civilized world would be outraged, if private property should be generally confiscated and private rights annulled. The people change their allegiance; their relation to their ancient sovereign is dissolved; but their relations to each other and their rights of property remain undisturbed. If this be the modern rule, even in cases of conquest, who can doubt its application to the case of an amicable cession of territory?—*United States vs. Percheman, 7 Peters, 51.*

"It is against the light of these considerations and authorities, and against the prevailing law and judgment of the Christian world, that it has been so often confidently, I will not say flippantly, asserted on this floor that there could be no doubt of our power, under the law of nations, to seize and confiscate the entire property of the rebels, as public enemies.

"I pass to the second branch of the subject, our power under the Constitution to pass these bills. It has been often said, in the course of this debate, and in terms without qualification, that the rebels hold to us the twofold relation of enemies and traitors, and that we may use against them all the appliances of war and all the penalties of municipal law. To a certain limited extent the proposition is sound. Treason consists in levying war against the United States. The act of treason is an act of war, and you use the powers of war to meet and subdue traitors in arms against the Government.

"It is also true that, in the relations between the Government and its subjects, the rightful power of punishment does not necessarily cease with the war; but is it also true that you can exercise both powers at the same time? And is not here the utter fallacy of this whole argument? Take an example. You have been accustomed to exchange flags of truce; you have recognized, to a certain extent, belligerent powers. An officer of the rebel army comes to you under a flag of truce: can you take him from under that flag and hang him for treason? He stands to you in the double relation of enemy and traitor, but you cannot touch a hair of his

head while he is under that white flag. Take another case. You have stipulated for an exchange of prisoners of war. The cartel has been sent, and the prisoner of war is on his way to make the exchange. Does any man on this floor say that you can take him on his way and try and hang him? And if not, why not? The plain answer is, because having recognized him as under the law of nations, while he is subject to its power, he is entitled to its protection.

"Pass what bills we may, Mr. Speaker, when the war is ended these questions will come up to be settled. I hope I may be pardoned for saying, with great respect, to my friends on all sides of the House, that they will be as difficult questions as statesmen or jurists were ever called upon to decide, and that it is wise to reserve, as far as possible, our judgment. No thoughtful man will content himself with the declaration that belligerent rebels have no rights. Passion may say that, reason never. Passion, sooner or later, subsides, and reason reascends the judgment seat, and these questions must be answered there and to that august tribunal before which the conduct of men and nations passes in review—the enlightened opinion of the Christian world. Such questions are, how far, *flagrante bello* (while war was raging), with respect to prisoners of war the civil power was restrained; how far the treating with rebels and exchanging them as prisoners of war may affect their punishment as traitors, either in person or property. I express no opinion, except to say they must be calmly met and answered.

"But assuming, for the sake of argument, that during the war even, and while recognizing their belligerent rights, you may visit upon the rebels the full force and weight of the municipal law, I proceed to inquire whether the mode proposed by these bills is in conformity to the organic and supreme law, the Constitution of the United States. I am not to be deterred from this discussion by any suggestions from weak or wicked men—none other can make them—of leniency to rebels and compassion for traitors. There is but little elevation in contempt, but such suggestions do not rise high enough to meet it. They pass by me as the idle wind. If a man has no other arrows in his quiver, let him use these; I am content.

"The favorite argument, Mr. Speaker, of those who claim for Congress the power to confiscate the property of traitors without trial by jury is, that the want of this power would show a fatal weakness in the Constitution and a lack of wisdom and foresight in its framers. They will not believe the Constitution is so weak and helpless, so incapable of self-defence. Nothing, in my judgment, so shows its majesty and strength, pray God, immortal strength. The powers of war are almost infinite. The resources of this vast country spring to your open hand. All that men have, even their lives, are at the service of their country; and

in this great conflict how nobly and freely given! You can raise an army of seven hundred thousand men; you can give them all the best appliances of war; you can cover your bays and rivers and seas with your navy; you can blockade a coast of three thousand miles; you may cut down the last rebel on the field of battle. Such is the power of war. But, Mr. Speaker, when you shall have used all these powers, when peace shall have been restored, or when the rebels shall come and lay themselves at your feet, or be taken captive by your arms, then, also, will the power of that Constitution be made manifest; then, also, will this Government be shown to be the most powerful and the noblest on the earth, not because the captured rebel is at your mercy, but because he is not. Because, under the shield of the Constitution, the rebel at your feet is stronger than armies, stronger than navies. You cannot touch a hair of his head or take from him a dollar of his property until you shall have tried and condemned him by the judgment of his peers and by the law of the land. Does this show the weakness of the Constitution, or does it show its transcendent strength? Are these written constitutions established to give to Government power, without limit, over the property, liberty, and life of the citizen, or are they made to define and limit the power of the Government, and to shield and protect the rights of the subject?

"I have always been taught that the people is the sovereign; that these constitutions are carefully defined grants from the sovereign power, so framed as to establish justice, and at the same time secure the blessings of liberty and the protection of law even to the humblest and meanest citizen. I know, Mr. Speaker, that these are getting to be old-fashioned sentiments. Magna Charta is soiled and worm-eaten. The Bill of Rights, the monuments of personal freedom, habeas corpus, trial by jury, what are they all worth in comparison with this new safeguard of liberty, the proceeding *in rem*?

"Was you ever at Runnymede, Mr. Speaker? I remember going down, on a beautiful day in July, from Windsor Castle to the plain, and crossing the narrow channel of the Thames to that little island on which, more than six centuries ago, in the early gray of morning, those sturdy barons wrested from an unwilling king the first great charter of English freedom—the germ of life of the civil liberty we have to-day. I could hardly have been more moved had I stood in the village and by the manger in which was cradled 'the Son of Mary and the Son of God.' From the gray of that morning streamed the rays which, uplifting with the hours, coursing with the years, and keeping pace with the centuries, have encircled the whole earth with the glorious light of English liberty—the liberty for which our fathers planted these commonwealths in the wilderness; for which they went through the baptism of fire and blood

in the Revolution; which they imbedded and hoped to make immortal in the Constitution; without which the Constitution would not be worth the parchment on which it was written.

"But I must not linger by the way, Mr. Speaker. What do these bills propose? The immediate object is to confiscate the property of the rebels. For what end? For punishment, is it not? If you strip these men of their property, it is not because they are innocent, although this bill does, in fact, confiscate the property of persons who may be guiltless of any offence. But the theory of the bill is to punish men for the crime of rebellion, or treason, or give it what name you will. The bill, indeed, recites, as an ulterior purpose, the payment of the expenses of the rebellion. But there is no man on this floor so verdant as to suppose this means much. If the courts enforce the statute (I believe they will not), how much treasure can you wring from those States, poor at the best, but whom the close of this war will leave impoverished, seared, and swept, as by fire? You might as well pasture your cattle on the desert of Sahara. The land will indeed be left, but who will be your purchasers, when they know they must take at the best a doubtful title, but a sure, bitter, and lasting feud. The strife and hate growing out of the confiscations of the Revolution are scarcely yet appeased, and it was with these confiscations fresh in the memories of the framers of the Constitution that the limitation of the power of forfeiture was adopted. There never was a wilder dream than that of paying the expenses of the rebellion with the fruits of confiscation.

"The real object of the bill is punishment, the punishment of an offence clearly defined in the Constitution, of the highest offence known to the laws. The punishment is the forfeiture of the property of the offender. The forfeiture is to be established before judicial tribunals, and upon proof of the guilt of the owner. You have, then, these three elements: punishment—upon proof of the commission of crimes—before a judicial tribunal. One element is wanting. One has been diligently excluded—trial by jury. Human ingenuity has been exhausted to shut the door against it, and your bill is like Hamlet with the Prince of Denmark omitted by particular request. Here is the plain imperative mandate of the Constitution, which he who runs may read:

The trial of all crimes except in cases of impeachment, shall be by jury.—*Constitution*, art. 3, sec. 2.

"The property to which the bill applies is not, under the law of nations, prize, it is not booty, it is not contraband of war. It is not enforced military contribution. It is not property used or employed in the war or in resistance to the laws, and, therefore, clearly to be distinguished from that covered by the statute of August 6, 1861. It is private property outside of the conflict of arms, forfeited not because it is the instrument of offence, but as a penalty

for the crime of the owner. The disguise of the proceeding *in rem* is too thin and transparent. No lawyer, no man of common sense will be deceived by it. The proceeding in spirit, in substance, and effect, is the punishment of treason by the forfeiture of a man's entire estate, real and personal, without trial by jury, and in utter disregard of the provision of the Constitution which limits the forfeiture for treason to the life of the person attainted. (Article 3, section 8).

"Was there ever a bolder contrivance to get around the plainest and most sacred provisions of the Constitution than this attempt to get a man's farm, his cattle and fodder, his plough, spade, and hoe into a maritime court and try them by the law of prize? With all respect for my excellent friends upon the committee, such a proposition 'shocks our common sense' as well as our sense of justice and right. You make the plea of necessity, and necessity is the mother of invention; but do you expect to satisfy sensible men, when reason resumes its sway, that under a Constitution which defines treason to consist in levying war against the United States, which will not suffer the traitor to be condemned except by the judgment of his peers, and when condemned will not forfeit his estate except during his life, you can, by this proceeding *in rem*, without indictment, without trial by jury, without the proof of two witnesses (article 3, section 8), for treason, for the act of levying war, deprive him of all his estate, real and personal, for life and in fee? Nay, more; and that, after he has thus been punished, without trial by jury, and by the loss of his whole estate, you can, for the same act of levying war, try him and hang him? To suggest a doubt whether, after all, this is plain sailing under the flag of the Constitution, is to have too nice constitutional scruples!"

After examining the details of the confiscation and emancipation bills, Mr. Thomas proceeded thus: "That the bills before the House are in violation of the law of nations and of the Constitution I cannot—I say it with all deference to others—I cannot entertain a doubt. My path of duty is plain. The duty of obedience to that Constitution was never more imperative than now. I am not disposed to deny that I have for it a superstitious reverence. I have 'worshipped it from my forefathers.' In the school of rigid discipline by which we were prepared for it, in the struggles out of which it was born, the seven years of bitter conflict, and the seven darker years in which that conflict seemed to be fruitless of good, in the wisdom with which it was constructed and first administered and set in motion, in the beneficent Government it has secured for more than two generations, in the blessed influences it has exerted upon the cause of freedom and humanity the world over, I cannot fail to recognize the hand of a guiding and loving Providence. But not for the blessed memories of the past only do I cling to it. He must be

blinded with excess of light, or with the want of it, who does not see that to this nation, trembling on the verge of dissolution, it is the only possible bond of unity. With this conviction wrought into the very texture of my being, I believe I can appreciate this conflict, can understand the necessity of using all the powers given by the Constitution for the suppression of this rebellion. They are, as I believe, and as the progress of our arms attests, ample for the purpose. I do not, therefore, see the wisdom of violating or impairing the Constitution in the effort to save it, or of passing from the pestilent heresy of State secession to the equally fatal one of State suicide. The fruits of the first are anarchy and perpetual border war; of the second the growth of military power, the loss of the centrifugal force of the States, the merging of the States in the central Government; a republic in name and form, in substance and effect a despotism."

Subsequently the bill before the House was passed, and sent to the Senate. It came up before that body on the 25th of June.

Matters had now reached a crisis in the Senate. A few of its members, determined, if possible, to secure the passage of all such measures as would extinguish slavery, conceiving that they had now reached the great and crowning act to be adopted. In the heat of their zeal, they had overlooked the Constitution and the courtesy due to the halting, conscientious convictions of more cool and considerate members. The result of the struggle which ensued was such as to convince these extreme Senators that the Senate was not yet ripe for, or 'educated up to' a compliance with their wishes.

Mr. Browning, of Illinois, took the floor. The special order was this bill from the House, and a substitute which had been moved. He said: "I deny and I defy, though I do not like to use that word, any man to point to one single word or letter in the Constitution which confers upon Congress any power to do any act in the exigency of war which it cannot do in times of peace. There, sir, is where the heresy lies. I give the Senator (Mr. Sumner's) own words, and while I desire to treat him with every possible respect, and have yielded to him repeatedly—a thing the Senator rarely does for the accommodation of anybody—I feel it incumbent upon me, as an American citizen, to say nothing of my position as a Senator, to enter my most earnest protest against this dangerous and revolutionary heresy that the powers of Congress are enlarged and amplified by a state of war. It overthrows the Government and accomplishes here in this Chamber what the rebels have not accomplished, and never can accomplish.

"Such, sir, are the extremities to which the Senator is driven, the inconsistencies in which he is involved, by his effort to compass an object which, in my humble judgment, is not only unconstitutional, but which, if successful, will

be fatal to the integrity of the Government itself, and change its entire character. Is it uncharitable to say that another object seems to lie much nearer the gentleman's heart than the crushing out of the rebellion and the re-establishment of the authority of the Government in all the States?

"I avow my object to be, with all the terrible enginery of war, to crush down and trample out, at once and forever, this wicked and diabolical rebellion; then to pursue and blast its leaders and fomenters with the severest punishments that can be visited upon this most malignant and unpardonable treason, and to win back the hearts of the deluded masses to the good old Government which protected them through all the past, and which they cannot, even now, remember without a tear of gratitude and a sigh of regret, and from the shelter of which they were cruelly enticed away to be exposed to the pelting of the pitiless storm of treason and rebellion which has wasted their fortunes, desolated their homes, murdered their families, embittered their lives, and darkened all their future. I wish to win them back; and, as the strongest possible inducement to return, I wish them to be fully assured that when they come they will find the same beneficent Government to which they had proved faithless, as magnanimous in mercy, as bounteous in blessing, as equal in justice, as zealous in protection, as when they betrayed it. Through weal and through woe, in the sunshine of peace and amid the storm and tempest of war, I wish to stand by the Constitution. I desire that every battle fought and every victory won, shall be fought and won under the Constitution and for the Constitution, and that every life that is poured out in this terrible strife shall be a libation to its great principles. Let us stand by the Constitution. We shall need its protection hereafter more than we ever have heretofore. We shall need its restraints in the times to come more than we ever have in the times that are past. When, hereafter, this Chamber shall be filled with Senators, fresh from the battle-field, whose laurels are yet green upon their brows, accustomed to command, and impatient of restraint, let there be no act of ours to be drawn into bad precedent in breaking down the bulwarks which the Constitution has erected for the security of the people. Let us leave no record behind to be pointed at as authority for encroachment upon the powers and prerogatives of a coordinate department. Power is always grasping, always struggling for the enlargement of its dominion. If we begin by denuding the Executive, how long will it be before the judiciary is stripped of its ermine, and all power concentrated in the hands of an irresponsible legislature? When that is done, the history of the Republic is closed and the history of anarchy and despotism begins its melancholy record of tyranny and oppression and confusion and blood."

Mr. Hale, of New Hampshire, said: "Sir, a doctrine has been advanced on this floor again and again, and reiterated and promulgated, which, to my mind, is more fatal in its character, more destructive of the Government, more at war with every principle of the Constitution, than secession itself. It is the doctrine that would concentrate all the executive power of the nation—when I say executive power, I speak of it in its broadest sense, its power of activity, its energy, its power to be something and do something—in the President of the United States, negating and denying to Congress any power at all. If that doctrine prevails your Constitution is gone, the dream of your fathers is over, the idea of a republic has vanished like the clouds of the morning before the rising glories of the sun, a practical despotism has stolen in upon us while our guardians have slept, the Constitution is perverted, and we are but a monarchy, having a name to live while we are in fact dead.

"I confess, sir, that if that is to be the Constitution we are to have left when the war is over, it is a matter of indifference to me whether the Federal or the confederate States prevail, for either of them will have but an iron despotism."

Mr. Sumner, of Massachusetts, thus explained what he regarded as the war power of the Government: "Pray, sir, where in the Constitution is the limitation of the war powers of Congress? Let Senators who would limit them mention a single section, line, or phrase, which even hints at any limitation. If it be constitutional to make war, to set armies in the field, to launch navies, to occupy fields and houses, to bombard cities, to kill in battle—all without trial by jury or any process of law or judicial proceedings of any kind—it is equally constitutional, as a war measure, to confiscate the property of the enemy and to liberate his slaves. Nor can it be doubted on principle that if the latter be unconstitutional, then are all the other agencies of war unconstitutional. You may condemn confiscation and liberation as impolitic, but you cannot condemn them as unconstitutional unless, in the same breath, you condemn all other agencies of war, and resolve our present proceedings into the process of a criminal court, guarded at each step by the technicalities of jurisprudence.

"Sir, I speak frankly, according to my convictions, claiming nothing for myself which I do not freely accord to others. In this discussion there is no need of sharp words or of personal allusions of any kind: nor can anything be gained by any misstatement of the position of another. It is easy to say that Senators who insist upon the war powers of Congress are indifferent to the Constitution; but I do not admit that any Senator is more anxious for the Constitution than myself. The war powers of Congress are derived from the Constitution, but, when once set in motion, are without any restraint from the Constitution, so that what is

done in pursuance of them is at the same time under the Constitution and outside the Constitution. It is under the Constitution in its beginning and origin. It is outside the Constitution in the latitude with which it may be conducted. But, whether under the Constitution or outside the Constitution, all that is done in pursuance of the war powers is constitutional. It is easy to cry out against it; it is easy, by misapplication of the Constitution, to call it in question; but it is only by such a misapplication, or by a senseless cry, that its complete constitutionality can for a moment be drawn into doubt.

"The language of the Constitution is plain and ample. It confers upon Congress all the specific powers incident to war, and then further authorizes it 'to make all laws which shall be necessary and proper for carrying into execution the foregoing powers.' Here are the precise words:

The Congress shall have power to declare war, to grant letters of marque and reprisal, to make rules concerning captures on land and water, to raise and support armies—to provide and maintain a navy; to make rules for the government and regulation of the land and naval forces; to provide for calling forth the militia to execute the laws of the Union, suppress insurrections, and repel invasion; and to make all laws which shall be necessary and proper for carrying into execution the foregoing powers, and all other powers vested by this Constitution in the Government of the United States, or in any department or officer thereof.

"Can language be clearer? There may be other parts of the Constitution open to question; but there is no room for question here. The text is full and unequivocal. The powers are enumerated. Without stopping to consider them in detail, it will be seen that the most important are exclusively incident to a state of war, and not to a state of peace. A declaration of war is of course war, and 'all laws necessary and proper for carrying into execution' this declaration are called into being by the war."

Mr. Browning, of Illinois, took up the positions advanced by Mr. Sumner, thus: "I intend to notice a few of the propositions of the Senator from Massachusetts. A fair example of his construction of constitutional provisions is found in his commentaries on this clause:

No soldier shall in time of peace be quartered in any house without the consent of the owner; nor in time of war, but in a manner to be prescribed by law.

"A custom obtained, a right of war was exercised by the British Government of quartering soldiers in private houses for their maintenance; not putting them in hospitals, sick and wounded, to be cared for; but soldiers who were engaged in the active prosecution of war. They quartered them, without the consent of the owners, upon the families of citizens, to be supported and maintained as long as the Government chose at the cost of the citizen and without his consent. The Senator, to make his construction of the Constitution good upon other clauses as well

as this, tortures this into a clause which would prohibit, if it were enforced, the taking of a rebel house to be used for the purposes of a hospital, or the appropriation of the house of any of our own citizens for hospital purposes. Now, sir, if the Senator really believes that the cases he has cited are within the purview of this clause of the Constitution, I certainly shall despair of ever producing any impression upon him by any constitutional argument I could enter into with him. And yet I think it is a fair specimen of his interpretation of all the clauses of the Constitution upon which he relies to establish his claim of despotic power; I will not say 'slavish;' I will not, as was said the other day, 'bandy words,' but I will say a claim of absolute and despotic power for a single department of the Government.

"The Senator claims that absolute and despotic power for Congress in the conduct of the war, and calls with something of an air of triumph upon those of us who deny it to point him to the limitation which the Constitution imposes upon the war powers of Congress. Mr. President, I have always understood the Constitution of the United States to be a grant of powers. It is true there are limitations. Its framers were not content with simply withholding grants; but in some cases—and that of confiscation was one—not content with withholding a grant of power, the convention did proceed to impose express limitations, and negated the possession and use of any such power. It did so in several instances. But, sir, the Constitution, instead of being a limitation upon the powers of Congress in the sense in which the Senator speaks of it, is a grant of powers, and Congress can exercise no power relating to war or peace that is not expressly granted to it by the Constitution.

"And now, sir, I ask him, when he claims this unlimited and despotic power for Congress on the conduct of the war, to point me to the grant of power in the Constitution, and not content himself by turning with an air of triumph and saying 'gentlemen have pointed to no limitation in the Constitution upon the war power.' Where is his grant of power? The only place that he professes to find it, I believe, is here:

Congress shall have power to make all laws which shall be necessary and proper for carrying into execution the foregoing powers—

the powers previously granted—

and all other powers vested by this Constitution in the Government of the United States, or in any department or officer thereof.

"Mr. President, I ask, is it seriously contended that the powers of Congress are one atom greater by the insertion of this provision than they would have been if it had never appeared in the Constitution at all?

"The gentleman insists that the Constitution confers upon Congress all the rights of war. I think I do not state him too largely. He says, in addition to that, that all the powers that are

granted to the President by the Constitution may be used by him in association with Congress; that he has no power which Congress may not, if it chooses, associate itself with him in the exercise of. One of the powers of war is the power to command the army. Does the Senator intend to be understood as insisting that Congress has the right and power, under the Constitution, to take the actual command of the army in the field?"

Mr. Sumner: "Is the Senator serious in putting the question?"

Mr. Browning: "Unquestionably, I am serious."

Mr. Sumner: "The Senator knows very well that by the Constitution of the United States the President is commander-in-chief of the army; but he also knows very well, that by the Constitution of the United States, Congress may make all laws to regulate the duties and the powers of the commander-in-chief. That is my answer to the question."

Mr. Browning: "Mr. President, I ask the Senator whether he was serious when he asserted that all the rights and powers of war were conferred by the Constitution upon Congress; whether he was serious when he further asserted that the President possessed no power which might not be used by him in association with Congress. I am serious in asking these questions, for these are doctrines which, in my judgment, are subversive of every principle of free government, which tend to establish, and which, if carried into legislation and into operation, will establish the most odious, despotic tyranny that the world ever saw.

"I do not intend to go any further into the argument, Mr. President. The Senator, repeating what had previously been said by another Senator, that the doctrine which had been advocated upon this floor, that the President could not be controlled by Congress in the exercise of the duties peculiarly devolving upon him by the Constitution, has chosen to characterize that as absurd and slavish, and deserving only of contempt, and, I believe he added, of execration. Mr. President, harsh and vulgar words prove nothing but the passion and malignity of him who uses them. They constitute no argument; they deserve no answer."

Mr. Howard, of Michigan, followed, saying: "I rise, Mr. President, to detain the Senate for a few minutes in the discussion of one single proposition, which has been frequently insisted upon during this debate respecting confiscation, that has run through so many weeks of this session—I mean the proposition which asserts the absolute authority of the President of the United States as derived from that provision of the Constitution which declares that he shall be commander-in-chief of the army and the navy and of the militia of the several States, when called into the actual service of the United States. If I understand this proposition correctly, it may be stated briefly thus: that in virtue of the clause of the Constitution which

I have recited, the Executive of the nation has the absolute, independent, irresponsible authority to control, use, and employ the army and the navy of the United States, and all the implements and instruments of war, as he pleases, not being, in these regards, subject to the control of Congress in any degree, and not being in any sense or degree responsible to Congress for the exercise of this supposed power, and not being subject to any legislation which the two Houses of Congress may adopt in reference to his authority.

"The question which I propose to discuss, as connected with this proposition, is, Has Congress authority under the Constitution to control and direct the President in the application and use of the military force of the nation in carrying on war, and is he bound to apply and employ it as they may direct? It is a simple question of power under the Constitution. All will admit its magnitude and importance.

"Sir, this new heresy deserves rebuke. It has been justly characterized by the Senator from Ohio (Mr. Wade) as slavish. And nothing is more certain than that, if it shall get a permanent hold on the public mind, we shall, in the no very distant future, lose our liberties or become a conquered people. And I warn the country against the insidious and fatal sophistry, as I warn them against the less insidious and far less fatal doctrine of secession. Secession must and will be refuted and put down by the arms of freemen; but when they, too, have consented to surrender the power of the sword wholly to the President, denying to their representatives all power to control him in the use of it; when Congress shall have abdicated this, the highest function of the national sovereignty, Cæsar has no Rubicon to pass; the boundaries of his military command, once fixed by the Senate, are blotted out forever. The consular general becomes a military dictator, an *imperator*, and all the powers of the Government, civil and military, pass into his irresponsible hands; his decrees will constitute the laws of the Republic, and his prætorian bands will make the President of the United States."

Mr. Browning, of Illinois, thus replied: "I will not occupy the attention of the Senate over five minutes. As my attention was especially invited by the Senator from Michigan to a portion of his speech, to all of which I have listened with interest, I think it proper that I should make a word of reply to that part to which he invited my attention. He, like every other Senator who contends for the new doctrine he advocates, is forced to go outside of the Constitution to find authority to sustain it, and no better authority has been found by the Senator than that of Washington's commission under the Continental Congress, and the practice of the Government under the Articles of Confederation. He says that Washington himself did not assume or pretend to claim any authority independent of the appointing power. Of course he did not; the Continental Congress



was the appointing power, and the Continental Congress was competent to impose any conditions, limitations, and restraints it chose to do, and it did impose them; so did the Congress under the old Articles of Confederation. And it was the continued and repeated blundering and bungling of military operations when controlled and governed by Congress that influenced the convention to ignore the doctrine, and separate forever the direction of the army from the control of Congress. It was the very authority upon which the Senator relies to sustain his doctrine that led to a change of the doctrine, and the clothing of the President of the United States with all the authority of commander-in-chief. Now, sir, the Constitution, and not Congress, is the appointing power of the commander-in-chief of the army and navy of the United States, and he is subject to all the restraints that the Constitution imposes upon him, and he is subject to none others. Congress can impose no restraint upon any power that is necessary to the execution of the office with which the Constitution clothes him.

"The gentleman, however, attributes to me a denial of all control by Congress over the army, or the commander-in-chief. I am perfectly willing to stand by my sentiments as I have myself uttered them. I am not willing to have attributed to me absurdities that I never entertained and never expressed, whether they result from a misunderstanding or from a misrepresentation of what I did say. I certainly do not intend to intimate that the Senator makes any wilful misrepresentations of my views; but they are upon record; I am willing to abide by them, defend them; but I am not willing to undertake the defence of all the absurdities that he suggests in interrogatories to me. I do not deny the control of Congress, and never have denied the control of Congress over the armies of the United States to the extent that the Constitution gives it control. I admit all the control which the Constitution has given; that is, Congress has power to raise armies and support armies. Congress may refuse to raise armies; it may refuse to support armies; it may disband armies after they are raised, and to that extent it can control the commander-in-chief, and to no other extent than the extent that the Constitution has authorized it to control him."

The debate was further continued in the Senate with much feeling among the members in favor of a confiscation bill. Mr. Cowan, of Pennsylvania, thus described the proceedings: "I came here with the firm conviction that it was the duty as well as the policy of the Republican party, the majority upon this floor, to take by the hand every loyal man who came from a Southern State, to forget any differences that we might have had before the territorial question of slavery (which was really settled by the election of Mr. Lincoln to the Presidency), to let that all be past and bygone, and all,

unitedly, as brothers, stand together, shoulder to shoulder, in order to suppress this rebellion. Could we have done this earnestly and heartily, confining our legislation solely to such laws as were necessary to raise and support our armies in the field, we should, in my judgment, have saved life and treasure, and we should have been nearer the end than we are to-day. But what has been the course of the school to which I have alluded? Why, sir, hardly a day has elapsed here that some measure was not introduced relating to slavery, and which was calculated to irritate, to wound, and to alienate those loyal and willing friends from us. How is it now? The gulf which separates the loyal men from the border States and the ultra school of the Republican party, is nearly as wide on this floor as that which separated the secessionists and the Republicans of former times. Mr. President, is that the way to suppress the rebellion? Never, never. Do the Senators from the Slave States say you are making friends for them by your projects of emancipation and confiscation, and all that kind of thing? They will tell you, and have told you, one and all, that instead of so doing, you are weakening them at home, and multiplying enemies against the Republic. Let the Senator from Minnesota go home and count his dead—and he has not one for every twenty that I have—and let him ask himself whether this unrelenting bitterness toward a whole people because they happen to live in Slave States, whether this fierce denunciation of that whole people at all times, and upon all occasions, without regard to their loyalty or disloyalty, whether the measures insisted upon here daily, and which were obnoxious to them, whether all that can be reconciled with an honest and sincere desire to put down this rebellion? I hope he may be satisfied with his answer; but if I were in his case, thinking as I do, I could not."

The bill from the House, which had been under consideration, was now amended by substituting the bill reported by the Special Committee of the Senate, by the following vote:

YEAS.—Messrs. Anthony, Browning, Clark, Collamer, Cowan, Davis, Dixon, Doolittle, Fessenden, Foot, Foster, Harlan, Harris, Henderson, Howe, Nesmith, Rice, Simmons, Stark, Ten Eyck, and Willey—21.

NAYS.—Messrs. Chandler, Grimes, Hale, Howard, King, Lane of Indiana, Lane of Kansas, Morrill, Pomeroy, Sherman, Sumner, Trumbull, Wade, Wilkinson, Wilmot, Wilson of Missouri, and Wright—17.

The bill from the House was drawn upon the principle that the confederates were belligerents, and could be proceeded against by all those measures which can be resorted to in a state of war. Those Senators who supported this bill also maintained the principle that Congress alone had the right to direct and control the war, and that the President was subject to their instructions. The key to these views is found in the fact that these Senators considered the immediate emancipation of the slaves the most important of all measures, and by this

route they hoped to achieve that end. On the other hand, the bill reported by the Special Committee of the Senate, contemplated the conviction and punishment of the traitor by due process of law, and authorized the President, whenever he deemed it expedient, to issue a prospective proclamation of emancipation. The confiscation of the property of principal offenders was the chief idea of the bill.

Mr. Trumbull, of Illinois, now moved to amend, by striking out the substitute reported by the Senate's committee, and to insert a bill from the House, authorizing emancipation. His remarks express his views on the position of the question, as follows: "Now, it is very manifest that the twenty-one Senators who voted a few minutes ago for a substitute to the House bill will never pass any confiscation bill. If it depends upon their votes, no confiscation bill will be passed, although they are quite willing to strike out a confiscation bill. The Senate has it in its power to make a law. The House has passed two bills. The Senate has the power to pass the bills of the House, and they are laws. The Senate also has it in its power to disagree with the House, and probably defeat any confiscation whatever. If some of the friends of confiscation think proper to unite with the enemies of all confiscation and disagree with the House and defeat any measure, that cannot be helped. Every Senator votes in view of his own responsibility, and if he thinks that the best course, he will, of course, pursue it. It is not my province to say anything about that for any other Senator than myself. I think that the wise policy would be, now that the House has passed measures, even if they were not quite satisfactory, to take them and enact them at once into laws. I think now it would be better to take up the other branch of the subject relating to emancipation, and substitute it, if the Senate would do so, in lieu of the amendment that the Senate proposes to adopt here; because then we shall adopt a measure that the House has agreed upon; that will be a law. But who supposes that the House will agree to the amendment that has been adopted here by the enemies of all confiscation aiding a few of its friends? Probably many persons do not want them to adopt it. That is the very thing they desire, to defeat any action. But I am for some action. I want something practical; and hence I want to agree to one of the House bills, if I cannot agree to the other; I would agree to both if I could, although they are not just such bills as I would prefer, particularly the confiscation bill."

A debate ensued which indicated much feeling on the part of the Republican Senators, who had been defeated in their bill, which was thus described by Mr. Wade, of Ohio: "Mr. President, I have witnessed, with a great deal of pain, the scenes that have been presented before us to-day in the Senate. I feel that the eye of the civilized world is upon us, and that on the Republican party of this continent now

rests the question of free government throughout the world. It seems so to me; and I say I am pained the more, because it seems to me that here is a radical division that has elicited a manifestation of some degree of feeling which may tend, not only on this important question, but on others, to divide that party on whom the hopes of the whole world must rest. We have stood together, shoulder to shoulder, upon the great questions which have come before us during this session, and never, in any legislative assembly, has so much been accomplished for the welfare of mankind, for the hope of the world, as has been accomplished thus far by the action of the Republican party in this Congress. Sir, posterity will be amazed at the great work we have performed thus far."

A vote was finally reached upon the bill, which passed, as follows:

YEAS.—Messrs. Anthony, Clark, Collamer, Cowan, Dixon, Doolittle, Fessenden, Foot, Foster, Grimes, Hale, Harlan, Harris, Howe, King, Lane of Indiana, Lane of Kansas, Morrill, Pomeroy, Sherman, Simmons, Sumner, Ten Eyck, Trumbull, Wade, Wilkinson, Willey, and Willmot—28.

NAYS.—Messrs. Bayard, Browning, Carlisle, Chandler, Davis, Henderson, Howard, Nesmith, Pierce, Powell, Stark, Wilson of Missouri, and Wright—13.

In the House, the amendment of the Senate was disagreed to—yeas 8, nays 124.

A committee of conference on the part of each House was appointed, and the Senate bill, with amendments, was reported and concurred in by the Senate and House.

Subsequently, a joint resolution explanatory of this act was passed in the House and sent to the Senate. It provided that the bill should be so construed "as not to apply to any acts done prior to its passage; nor to include any member of a State legislature, or judge of any State court who has not, in accepting or entering upon his office, taken an oath to support the constitution of the so-called Confederate States of America."

Mr. Clark, of New Hampshire, also offered the following, to be added to the resolution:

Nor shall any punishment or proceedings under said act be so construed as to work a forfeiture of the real estate of the offender beyond his natural life.

Mr. Trumbull, of Illinois, objected, saying: "I cannot consent to that amendment. The Senate will observe that it is a very important amendment. It provides that you shall confiscate the real estate only for life. What will that amount to? What is a life estate worth in lands in the West, where these traitors chiefly hold their real estate? It is not worth anything; it amounts to nothing."

Mr. Clark, of New Hampshire, replied: "I trust the amendment will be agreed to. It may be sometimes desirable to secure as much as we can, if we cannot get all we wish. I would desire to get the real estate in fee; but if we cannot do that, it may be worth while for us to consider whether we will not take the personal property of the individual and the real estate for life, if we cannot get the estate in fee."

Mr. Sherman, of Ohio, said: "I should like to know by what authority the Senator says we cannot get any more, because if we are acting under a kind of duress, I want to understand it."

Mr. Clark replied: "I do not say that we are acting under any duress; but it may be that there may be objections to the bill as it now stands, somewhere, and it may be that an amendment like this will cure the difficulty and enable us to get over it. I suggest to Senators whether it may not be better to adopt the amendment in that view of it, rather than to reject it."

Mr. Sherman: "If the Senator from New Hampshire will state to us in explicit language that the President of the United States will veto the bill unless we pass this amendment, I am in favor of passing it; but I want to throw that responsibility upon those who ought properly to assume it. I will not shirk myself, and I do not want anybody else to shirk. If the President desires to say that in his view of the Constitution—and I do not criticise him—he wishes this amendment in order to enable him conscientiously to sign the bill, I will pass it; but I want him to take that position before the people of the United States."

Mr. Clark: "Mr. President, I think I may say that I am authorized to declare that I do know that that is one of the objections made to the bill by the President, and it is with a view of removing that objection and inducing his signature to the bill that I offer this amendment, not that it satisfies me."

Mr. Sherman: "Then I will vote for it."

Mr. Clark: "There is one other amendment that I propose to make, and I may as well, as I am upon the floor, state what that is. I propose, after this amendment be adopted, if it shall be adopted, to move this further amendment:

*"And be it further resolved,* That the words granting an amnesty in the thirteenth section of said act shall be so construed as to authorize the President to restore the offender any property which may have been seized and condemned under any proceedings of this act, or the proceeds thereof."

Mr. Grimes, of Iowa, said: "Will the Senator state whether that is also at the instance of the President?"

Mr. Clark: "It is. The thirteenth section of the bill provides:

That the President is hereby authorized, at any time hereafter, by proclamation, to extend to persons who may have participated in the existing rebellion in any State, or part of a State, pardon and amnesty, with such exceptions, and at such times and on such conditions as he may think fit.

"The question was, whether that would authorize him, if a man showed himself to be innocent, to restore his property; and it is only to extend the words to give him that privilege, if he finds the man has been innocent, to let him have his property back again."

Mr. King, of New York, likewise objected to

the amendment, saying: "Mr. President, this mode of proceeding presents to us a question that is entirely new. We are called upon to make a precedent as to the manner in which communications shall take place between coördinate branches of the Government in the exercise of their powers. I look upon it as a graver question, if possible, than the merits of this particular proposition.

"I am astonished that this proposition should be made. I regret it. I think it ought not to be made or acted on."

Mr. Fessenden, of Maine, said: "Now, sir, what is the part of common sense under such circumstances? If all the essential features of the bill can be retained, or if the greater number of the most essential features can be secured by yielding one, without which the bill cannot become a law, or may not become a law, what is the objection, as a matter of common sense and common prudence, to taking the best we can and the most we can under such circumstances? Is there any loss of dignity in that? Is there any loss of character on the part of the Senate? Is it better that no bill be passed with regard to this object, which gentlemen profess to have, and have, so much at heart? Is it best to have an open defiance, and to say that nobody shall have an opinion but ourselves? That would seem to be the inference from the argument. I have always been opposed to that idea. While I am very anxious to have my own views carried out into practice, I acknowledge the same right on the part of others in the same position with myself, and those in a different position from myself, if they are to act on the same subject."

Mr. Powell, of Kentucky, proposed an amendment, saying: "I now notify the Senate that at the proper time I will move to amend the pending amendment by striking out the word 'real' before 'estate,' so that, confining the forfeiture to life, it shall apply to all estates, both real and personal; and upon that point I will remark very briefly.

"I am clearly of opinion, and have expressed it heretofore in the Senate, that the clause in the Constitution which declares that 'no attainder of treason shall work corruption of blood or forfeiture, except during the life of the personal attainted,' applies both to personal and real estate. The chief object I have in view now, however, is to call the attention of the Senate to a very short, but in my mind a very cogent argument that cites the authorities on this subject. I have delivered to the clerk a written article upon this very subject, which was sent to me some days ago, by Judge Nicholas, of Louisville, Kentucky, who is one of the best lawyers in the country, and he has written most luminously on all this subject of confiscation and the war power. Judge Nicholas cites the opinions expressed upon this point by the Senator from Illinois (Mr. Browning), and by the Senator from Massachusetts (Mr. Sumner), and he makes his argument, adduces

his authorities, to overthrow the error into which those Senators had fallen.

"I am delighted, sir, to see that the President has indicated a desire to regard the Constitution in this measure. I pray God that he will do it in all cases, and I am sorry he has not heretofore done it more resolutely than he has. I now ask the clerk to read the manuscript that I have placed in his hands."

The Secretary read as follows :

*Forfeiture—Confiscation.*—"Personalty, by the English law, was never forfeited by an attainer of treason. It was the realty, and the realty only, that the attainer acted on; and when they say no attainer shall hereafter work a forfeiture, they mean it shall not hereafter work a forfeiture upon the same estate that it heretofore acted upon. An attainer never did act upon the personalty at all, never touched it; it affected the realty only, leaving the personalty to be dealt with as the wisdom of Congress might see fit."

—*Senator Browning, Congressional Globe, 2171.*  
 "It is admitted by Senators that the words of the Constitution do not forbid the forfeiture of personal estate; so that a person attainted of treason would be made to forfeit all his personal estate, no matter what its amount."—*Senator Sumner, Congressional Globe, 2190.*

To prevent a repetition of such gross, pernicious blunders, the attention of those Senators and others is invited to the following citations from so familiar and accurate an authority as Blackstone's Commentaries :

"By attainer for treason or other felony, forfeiture of lands and of whatsoever else the offender possessed, was the doctrine of the old Saxon law."—*Vol. 2, 251.*

"Upon judgment of outlawry or of death, for treason or felony, a man shall be said to be attainted."—*Vol. 4, 381.*

"The forfeiture of goods and chattels accrues in every one of the higher kinds of offence: in high treason or misprision thereof, petit treason, felonies of all sorts, whether clergyable or not," &c.—*Vol. 4, 386.*

"There is a difference between the forfeiture of lands and of goods and chattels. Lands are forfeited upon attainer and not before; goods and chattels are forfeited by conviction. Because, in many of the cases where goods are forfeited there never is any attainer; which happens only where judgment of death or outlawry is given. The forfeiture of lands has relation to the time of the fact committed, so as to avoid subsequent sales and conveyances; but the forfeiture of chattels has no relation backwards; so that those only which a man has at the time of conviction shall be forfeited. Therefore, a traitor or felon may, *bona fide*, sell any of his chattels, real or personal, between the fact and conviction, for no buyer could be safe if he were liable to return the goods he had fairly bought, provided any of the prior vendors had committed treason or felony."—*Vol. 4, 387.*

Therefore the Constitution, in saying "no attainer of treason shall work forfeiture except during the life of the person attainted," includes personal as much as real estate.

Therefore, also, Congress can in no way, directly or indirectly, punish treason by emancipation, for *quo ad* the punishment of treason the owner of a slave has only a life estate, and the owner of such life estate has no power of emancipation. Or, at most, all that Congress could do in the way of penalty, would be to emancipate during the life of the owner; but this would be so manifestly unjust to the remainder-man that no fair-minded person would contend for that mode of exercising the power.

There is still a stronger reason against such exercise of the supposed power. Senator Sumner, in the same speech (page 2190) admits: "Congress has no power under the Constitution over slavery in the States." "Congress has no direct power over slavery in the States so as to abolish or limit it." Now, all the slave

States prohibit emancipation, except in the manner their statutes specially prescribe. Congress can rightfully, legally, do nothing in reference to this peculiar property, whether by way of punishment or otherwise, in violation of this necessary settled policy of those States. Congress may forfeit and hold, or forfeit and sell slaves by due process of law in punishment of treason, but the Government or its purchaser must take and hold the property subject to the State law.

This equally disposes of all claim of power in the President, or of one of his sub-military commanders, to emancipate by proclamation. They can have in that particular, or any other no power not given by Congress expressly or impliedly. As Congress cannot give such power directly, it cannot be implied. If claimed as an incident to the right of eminent domain, then it becomes private property taken for public use, for which just compensation must be made to the owner according to the recent precedent of emancipation in the District of Columbia. If claimed as an incident to the power of carrying on the war, then it is met by that highest authority, the Declaration of Independence, denouncing it as contrary to the usages of civilized warfare. It therefore cannot be implied in the silence of the rules and articles of war, nor can Congress rightfully make it part of them.

Respectfully submitted by S. S. NICHOLAS.

The amendment moved by Mr. Powell was rejected.

Mr. Harris, of New York, thus explained the proposition before the Senate: "Mr. President, the bill in question, as it has passed both House of Congress, provides for the seizure and condemnation of the property of rebels in two ways: first, where the traitor has been proceeded against personally and convicted. In that case, the first section of the bill provides that a fine may be imposed upon him, and that his property may be sold for the payment of that fine. His whole estate in the realty may, under the provisions of that section, be divested. The Senator from Illinois thinks that provision is unconstitutional, and yet he has supported the bill and desires to have it a law. He thinks that, under the provisions of that section, only the life estate can be divested. So the President thinks. Thus far they agree.

"Now there is another provision of that bill which the Senator from Illinois does not seem to understand. He has stated that it is provided in the bill that the real estate of the rebel may be seized by the army, and made a prize or capture of war. The Senator is mistaken about that. The seventh section of the bill provides that where the proceeding is not against the rebel *in personam*, where there are no personal proceedings against him, his estate may be seized by the Government by a proceeding *in rem*, and condemned and sold. The President thinks that that proceeding *in rem* against the property instead of the person is equally unconstitutional with the other; and I am not sure that the Senator from Illinois would not think so. It is accomplishing indirectly what the first section accomplishes directly, in my judgment. The one is a judgment *in rem* against the property, the other is a judgment *in personam*, accompanied with a fine under which the property is sold. The Senator from Illinois and the President differ

widely in respect to this. The principle is the same. The Senator has entirely misapprehended, at least it would seem so from the remarks he has made, the scope and extent of the provisions of this bill in regard to proceedings *in rem*. If I understand the bill, the seventh section of the bill provides for the seizure of rebel property where there are no proceedings against the person, not by the army merely, but by proceedings instituted on behalf of the Government by the executive department of the Government. It seems to me that the Senator from Illinois is of all others the last person who should object to this explanatory provision by which the bill is made to conform to his own principles."

The joint resolution, with the amendments, was subsequently passed in the Senate and approved by the House.

The bill and joint resolution were signed by the President, after which he sent the following Message to the House.

*Fellow Citizens of the Senate and House of Representatives :*

Considering the bill for "An act to suppress insurrection, to punish treason and rebellion, to seize and confiscate the property of rebels, and for other purposes," and the joint resolution explanatory of said act, as being substantially one, I have approved and signed both.

Before I was informed of the resolution, I had prepared the draft of a Message, stating objections to the bill becoming a law, a copy of which draft is herewith submitted.

ABRAHAM LINCOLN.

July 12, 1862.

[Copy.]

*Fellow Citizens of the House of Representatives :*

I herewith return to your honorable body, in which it originated, the bill for an act entitled "An act to suppress treason and rebellion, to seize and confiscate the property of rebels, and for other purposes," together with my objections to its becoming a law.

There is much in the bill to which I perceive no objection. It is wholly prospective; and it touches neither person nor property of any loyal citizen, in which particular it is just and proper.

The first and second sections provide for the conviction and punishment of persons who shall be guilty of treason, and persons who shall "incite, set on foot, assist, or engage in any rebellion or insurrection against the authority of the United States, or the laws thereof, or shall give aid or comfort thereto, or shall engage in or give aid and comfort to any such existing rebellion or insurrection." By fair construction, persons within those sections are not punished without regular trials in duly constituted courts under the forms and all the substantial provisions of law and the Constitution applicable to their several cases. To this I perceive no objection; especially as such persons would be within the general pardoning power, and also the special provision for pardon and amnesty contained in this act.

It is also provided that the slaves of persons convicted under these sections shall be free. I think there is an unfortunate form of expression, rather than a substantial objection, in this. It is startling to say that Congress can free a slave within a State, and yet if it were said the ownership of the slave had first been transferred to the nation, and Congress had then liberated him, the difficulty would at once vanish. And this is the real case. The traitor against the General Government forfeits his slave at least as justly as he does any other property; and he forfeits both to the Government against which he offends. The Government, so far as there can be ownership, thus owns the forfeited slaves, and the question for Congress in re-

gard to them is, "Shall they be made free or sold to new masters?" I perceive no objection to Congress deciding in advance that they shall be free. To the high honor of Kentucky, as I am informed, she is the owner of some slaves by *escheat*, and has sold none, but liberated all. I hope the same is true of some other States. Indeed, I do not believe it will be physically possible for the General Government to return persons so circumstanced to actual slavery. I believe there would be physical resistance to it, which could neither be turned aside by argument, nor driven away by force. In this view I have no objection to this feature of the bill. Another matter involved in these two sections and running through other parts of the act will be noticed hereafter.

I perceive no objections to the third and fourth sections.

So far as I wish to notice the fifth and sixth sections, they may be considered together. That the enforcement of these sections would do no injustice to the persons embraced within them is clear. That those who make a causeless war should be compelled to pay the cost of it is too obviously just to be called in question. To give governmental protection to the property of persons who have abandoned it and gone on a crusade to overthrow that same Government is absurd, if considered in the mere light of justice. The severest justice may not always be the best policy. The principle of seizing and appropriating the property of the person embraced within these sections is certainly not very objectionable, but a justly discriminating application of it would be very difficult, and, to a great extent, impossible. And would it not be wise to place a power of remission somewhere, so that these persons may know they have something to lose by persisting and something to gain by desisting? I am not sure whether such power of remission is or is not within section thirteen. Without any special act of Congress, I think our military commanders, when, in military phrase, "they are within the enemy's country," should, in an orderly manner, seize and use whatever of real or personal property may be necessary or convenient for their commands; at the same time preserving, in some way, the evidence of what they do.

What I have said in regard to slaves while commenting on the first and second sections is applicable to the ninth, with the difference that no provision is made in the whole act for determining whether a particular individual slave does or does not fall within the classes defined in that section. He is to be free upon certain conditions; but whether those conditions do or do not pertain to him, no mode of ascertaining is provided. This could be easily supplied.

To the tenth section I make no objection. The oath therein required seems to be proper, and the remainder of the section is substantially identical with a law already existing.

The eleventh section simply assumes to confer discretionary power upon the Executive. Without the law, I have no hesitation to go as far in the direction indicated as I may at any time deem expedient. And I am ready to say now, I think it is proper for our military commanders to employ, as laborers, as many persons of African descent as can be used to advantage.

The twelfth and thirteenth sections are something better than unobjectionable; and the fourteenth is entirely proper, if all other parts of the act shall stand.

That to which I chiefly object pervades most part of the act, but more distinctly appears in the first, second, seventh, and eighth sections. It is the sum of those provisions which results in the divesting of title forever.

For the causes of treason and ingredients of treason, not amounting to the full crime, it declares forfeiture extending beyond the lives of the guilty parties; whereas the Constitution of the United States declares that 'no attainer of treason shall work corruption of blood or forfeiture, except during the life of the person attainted.' True, there is to be no formal attainer in this case; still, I think the greater punishment cannot

be constitutionally inflicted, in a different form, for the same offence.

With great respect I am constrained to say I think this feature of the act is unconstitutional. It would not be difficult to modify it.

I may remark that the provision of the Constitution, put in language borrowed from Great Britain, applies only in this country, as I understand, to real or landed estate.

Again, this act, *in rem*, forfeits property for the ingredients of treason without a conviction of the supposed criminal, or a personal hearing given him in any proceeding. That we may not touch property lying within our reach, because we cannot give personal notice to an owner who is absent endeavoring to destroy the Government, is certainly satisfactory. Still, the owner may not be thus engaged; and I think a reasonable time should be provided for such parties to appear and have personal hearings. Similar provisions are not uncommon in connection with proceedings *in rem*.

For the reasons stated, I return the bill to the House in which it originated.

Some of the acts of a general nature passed at this session of Congress, provided for the following purposes:

The number of members of the House of Representatives was fixed at two hundred and forty-one. Eight additional members were assigned, one each to Pennsylvania, Ohio, Kentucky, Illinois, Iowa, Minnesota, Vermont, and Rhode Island.

The following additional article of war was adopted for the government of the army and navy:

**ARTICLE.** — All officers or persons in the military or naval service of the United States are prohibited from employing any of the forces under their respective commands for the purpose of returning fugitives from service or labor, who may have escaped from any persons to whom such service or labor is claimed to be due, and any officer who shall be found guilty by a court martial of violating this article shall be dismissed from the service.

The act for the abolition of slavery in the District of Columbia emancipated all persons of African descent held to service in the District immediately upon its passage; loyal owners of slaves only were allowed ninety days to prepare and present to commissioners appointed for that purpose the names, ages, and personal description of their slaves, who were to be valued by the commissioners. No single slave could be estimated to be worth more than three hundred dollars. The amount of these claims was to be paid to each owner after the final report of the commissioners at the end of nine months. One million of dollars was appropriated to carry the act into effect. The sum of one hundred thousand dollars was appropriated to colonize any of the liberated slaves, who might desire to go to Hayti, Liberia, or any country beyond the limits of the United States, as the President might select.

A department of agriculture was established, the design and duties of which are to acquire and to diffuse among the people of the United States useful information on subjects connected with agriculture in the most general and comprehensive sense of that word, and to procure,

propagate, and distribute among the people new and valuable seeds and plants.

A commissioner, with a salary of three thousand dollars, and a chief clerk, with a salary of two thousand dollars, are the officers of the department.

An act to secure homesteads to actual settlers on the public domain, provides that any loyal citizen of twenty-one years of age or upward, or one who has filed his intention to become a citizen, may enter one quarter section or a less quantity of unappropriated public land upon which such persons may have filed a preemption claim, or is subject to preemption. The applicant must file an affidavit that the said entry is made for actual settlement and cultivation, and not for the use or benefit of any other person. No certificate is given or patent issued until the land has been occupied and cultivated for five years by the applicant. No land thus acquired can become liable for the satisfaction of any debt contracted previous to the issue of the patent. No individual can acquire title to more than one quarter section under the act.

An act was passed to provide for the construction of a railroad and telegraph line from the Missouri river to the Pacific Ocean.

The following sections of an act to punish and prevent the practice of polygamy in the Territories of the United States, &c., were enacted:

The first section punishes with a fine of five hundred dollars and imprisonment not exceeding five years, any person convicted of bigamy in any Territory of the United States.

**SEC. 2.** *And be it further enacted,* That the following ordinance of the provisional government of the State of Deseret, so called, namely: "An ordinance incorporating the Church of Jesus Christ of Latter Day Saints," passed February eight, in the year eighteen hundred and fifty-one, and adopted, reenacted, and made valid by the Governor and Legislative Assembly of the Territory of Utah by an act passed January nineteen, in the year eighteen hundred and fifty-five, entitled "An act in relation to the compilation and revision of the laws and resolutions in force in Utah Territory, their publication, and distribution," and all other acts and parts of acts heretofore passed by the said Legislative Assembly of the Territory of Utah, which establish, support, maintain, shield, or countenance polygamy, be, and the same hereby are, disapproved and annulled: *Provided,* That this act shall be so limited and construed as not to affect or interfere with the right of property legally acquired under the ordinance heretofore mentioned, nor with the right "to worship God according to the dictates of conscience," but only to annul all acts and laws which establish, maintain, protect, or countenance the practice of polygamy, evasively called spiritual marriage, however disguised by legal or ecclesiastical solemnities, sacraments, ceremonies, consecrations, or other contrivances.

**SEC. 3.** *And be it further enacted,* That it shall not be lawful for any corporation or association for religious or charitable purposes to acquire or hold real estate in any Territory of the United States during the existence of the territorial government of a greater value than fifty thousand dollars; and all real estate acquired or held by any such corporation or association contrary to the provisions of this act shall be forfeited and escheat to the United States; *Provided,*

That existing vested rights in real estate shall not be impaired by the provisions of this section.

Every person hereafter elected or appointed to any office of honor or profit under the Government of the United States, either in the civil, military, or naval departments, except the President, is, by another act, required to take the following oath before entering upon the duties of such office:

I, A B, do solemnly swear (or affirm) that I have never voluntarily borne arms against the United States since I have been a citizen thereof; that I have voluntarily given no aid, countenance, counsel, or encouragement to persons engaged in armed hostility thereto; that I have neither sought, nor accepted, nor attempted to exercise the functions of any office whatever, under any authority or pretended authority in hostility to the United States; that I have not yielded a voluntary support to any pretended government, authority, power, or constitution within the United States, hostile or inimical thereto. And I do further swear (or affirm) that, to the best of my knowledge and ability, I will support and defend the Constitution of the United States against all enemies, foreign and domestic; that I will bear true faith and allegiance to the same; that I take this obligation freely, without any mental reservation or purpose of evasion, and that I will well and faithfully discharge the duties of the office on which I am about to enter, so help me God.

The Confiscation, Tax, Tariff, and Militia Laws are noted elsewhere in these pages.

This session of Congress closed on the 17th of July, 1862. It was marked by industry on the part of the members, and a disposition not only to sustain the Executive in the conflict with the Confederate States, but to urge him to all such measures as should tend to liberate the slaves in those States. It is a singular fact that not a proposition for conciliation or one that looked to a redress of any conceived grievance on the part of the South was entertained in either House. One was offered by Mr. Saulsbury, of Maryland, on the second day of the session, and immediately laid on the table. It does not appear to have been alluded to afterward, nor was any other offered. The resolutions expressing the sense of Congress on the object of the war adopted at the previous session were repudiated, and bills providing for the emancipation of the millions of slaves through the confiscation of all the property of disloyal owners in those immense Southern States, were passed into laws.

Slavery, and the laws regulating it, were abolished in the District of Columbia. Slavery was forbidden in all the Territories of the United States. Liberia and Hayti were recognized as independent republics, and as belonging to the family of nations. A new treaty, relative to the slave trade, was ratified with Great Britain, which allowed to her the liberty of searching American vessels under certain circumstances. All persons in the army or navy were prohibited from returning slaves, or sitting in judgment on the claim of their masters. The slaves of disloyal persons in the Confederate States were declared to be emancipated on coming within the lines of the Federal army. A reso-

lution to tender compensation to loyal masters on the voluntary emancipation of their slaves was also adopted by Congress:

CONNECTICUT, one of the Eastern or New England States, first settled in 1633. Area, 4,674 square miles. Population in 1860, 460,147. Governor till first Wednesday in May, 1863, William A. Buckingham, of Norwich. Secretary of State, till same date, James Hammond Trumbull, of Hartford. The election for State officers takes place on the first Monday of April. At the election of April, 1862, the total vote was 70,480, of which William A. Buckingham received 39,782, and was elected. The Legislature consists of 21 senators, and 251 representatives. The Senate was unanimously Republican. The House of Representatives had 195 Republican members, and 56 Democrats. The State expenditure for the year, aside from school-fund revenue, was \$2,148,257, of which about \$1,866,097.52 was for war purposes; two thirds of this amount would be refunded by the general government. The valuation of the State, as returned by the assessors, which does not include State or other property exempt from taxation, and estimates real estate much below its true value, was \$254,742,695. The census valuation in 1860, which probably comes nearer the actual property of the State, was \$444,274,114. The resources and liabilities of the banks of the State in April, 1862, amounted to \$39,211,643, the capital of the banks being \$21,790,937, their circulation, \$8,023,681, and the specie in their vaults \$1,518,317. The assets of the savings banks of the State (forty-five in number) were \$20,539,758.55, showing a surplus of \$556,799.11 over their liabilities. The railroad property of the State (twelve railroads) cost about \$26,000,000, and seven of the twelve roads paid dividends during the year, varying from two to twelve per cent. The total expenditure for common-school purposes during the year was \$486,000, of which \$130,850.40 was from the revenue of the school fund. The State has a normal school, with 9 teachers and 174 pupils, and three colleges, with 55 professors and instructors and 809 students. There are also an asylum for the deaf and dumb, at Hartford, the first founded in the United States, with 18 teachers and 222 pupils, and the Connecticut School of Imbeciles, at Lakeville, Litchfield county, with 2 teachers and 19 pupils, and a State reform school at West Meriden, with 148 inmates. The Retreat for the Insane, at Hartford, is an incorporated institution, founded in 1824, and had in April, 1862, 221 patients. It is under the charge of John S. Butler, M. D. The State had increased its population during the decade ending in 1860 by 89,355 inhabitants, or 24.10 per cent; but this increase was almost entirely in the cities and large towns, the increase of New Haven county being 81,757, of which 18,922 was in the city of New Haven, and nearly 6,000 in the city of Waterbury, while the remainder was distributed

through the large manufacturing towns of the county; Hartford county had increased 19,995, of which 15,599 was in the city of Hartford, and most of the remainder in the towns of New Britain and Windsor Locks; Fairfield county had increased 17,701, almost entirely in the large towns along the Sound shore; New London county had gained 9,910, of which 4,905 was in her two cities, New London and Norwich; while the other four counties, which were mainly agricultural, and contained among them but one city, and few considerable towns, had gained but 9,992 in the aggregate, though embracing about  $\frac{1}{4}$  of the population of the State. The State is largely engaged in manufacturing, its aggregate industrial products being stated in round numbers at \$38,000,000. The cash value of its farms and farming implements was \$98,169,486. Connecticut had furnished to November 10, 1862, 28,551 men for the volunteer army. They constitute twenty-seven regiments of infantry, one regiment of heavy artillery, two batteries of light artillery, and one battalion of cavalry. At the close of the year, six regiments, one battery, and the battalion of cavalry were at different points in Virginia, one regiment in Maryland, six in North Carolina, two and a battery at Hilton Head or its vicinity, three in New Orleans, and the remainder in camp awaiting orders, or recruiting. The quota required to fill the two calls of July and August, 1862, being short about 2,000 on the 10th of September, Governor Buckingham directed a draft to be made in the towns where there was a deficiency on that day. In New Haven, Hartford, and some other towns, the deficiency was made up by volunteering before the day closed, bounties of large amounts being offered by patriotic citizens to volunteers. In other places the draft was made. Slight opposition was offered in Fairfield and Newtown, but it was soon quelled, without any injury. In all, 1,212 persons were drafted, but of these only 218, of whom 142 were substitutes, were mustered into the service of the United States, 81 having deserted after reporting at camp; 628 were exempted by surgeons and selectmen, 10 had previously volunteered, 34 were not subjects of military duty, and 166 were unaccounted for on the 12th of December, 1862. The number needed was, however, made up by volunteers.

At its regular session, in May, 1862, the Legislature passed a militia law, or rather revised and modified that of the previous year, which had proved objectionable in many particulars. This law divided the able-bodied males of the State between the ages of eighteen and forty-five, except the usual State and United States exempts, into two classes, the active and inactive militia; the first to consist of all the vol-

unteer companies then in existence, or who might be organized under the act, and to constitute one division of such number of brigades and regiments as the commander-in-chief (the governor of the State) should direct; the second class (inactive militia) to be composed of all other able-bodied persons not exempt, to be enrolled, and (except minors) to pay a commutation tax of one dollar per annum, and not to be liable to serve except in case of rebellion or invasion of the State, when they might be drafted by the commander-in-chief to fill up the ranks of the active militia. The organized, or active militia, were required to be properly armed and equipped, arms being furnished by the State, and a sum allowed for the rent of an arsenal. They were to be paid two dollars a day and mileage when mustered for drill and camp duty, and if belonging to a cavalry corps were allowed two dollars more for horse hire per day. They were also exempted from the commutation tax and jury duty. The officers were obliged to assemble once a year for officers' drill, under a competent drill master, and were compensated for the time thus spent. The law does not seem to have been perfect in its operations, much complaint being made in regard to it.

The expense of fitting out and providing for so large a number of troops as was called for by the President's proclamations in July and August, 1862, having drained the treasury, and causing a large prospective deficit, Governor Buckingham deemed it necessary to call a special session of the Legislature, which met in Hartford on the 9th of December, 1862. In his message, addressed to them, the governor stated the inefficiency of the draft, showed the defects of the militia law, and advocated the extension of suffrage to the soldiers in the field. He also recommended that the State bonds be issued for a definite number of years, and that the towns be allowed to issue bonds. The funded debt of the State was \$2,000,000, and the unfunded debt amounted, on the 1st of December, to \$1,212,800. Exclusive of this unfunded debt, and of new appropriations, the estimated necessities of the treasury to the 31st of March, the close of the financial year, were \$768,338, and the estimated receipts only \$642,580, leaving a deficiency of \$125,758, which, added to the unfunded debt, made the entire indebtedness to be provided for \$1,388,558. Nearly one half of this was for bounties to volunteers. The Legislature passed an act authorizing a loan of \$2,000,000, which was taken in February, 1863, at about twelve per cent. premium. They also passed a law permitting the soldiers in the field to vote for State officers, but this was subsequently pronounced by the judges of the supreme court of the State unconstitutional. They also made some modifications in the State militia law.



## D

DECATUR, a village in Morgan co., Alabama, is on the left bank of the Tennessee river, and thirty miles west of southwest of Huntsville. It is one hundred and twenty-two miles from Nashville in Tennessee, and is the termination of a railroad from Nashville to Decatur, which crossed the Tennessee river by a long bridge. This bridge was burnt by a Federal force of the division of Gen. Mitchell to prevent the pursuit of a Confederate force. The Memphis and Charleston railroad passes through Decatur, which is 188 miles from the former point. Steamboats of light draft descend the Tennessee from this point into the Ohio and Mississippi rivers.

DELAWARE, one of the Middle Atlantic States, first settled in 1627. Its area is less than that of any other State of the Union except Rhode Island, being 2,120 square miles. Its population in 1860 was 112,216. The governor elected in Nov. 1862, for four years from Jan. 1863, was William Cannon of Bridgeville; the Secretary of State appointed by the governor elect and holding office for the same time, was Nathaniel B. Smithers, of Dover. At the election on the 2d Tuesday of November, 1862, the Republican Union candidate for Governor, Cannon, received 8,155, while Samuel J. Jefferson, the democratic candidate, received but 8,044. For Congress, William Temple, the democratic candidate, had 8,051 votes, and was elected; the Republican Union candidate, George P. Fisher, having only 8,014. The Senate, composed of 9 members, has 5 democrats and 4 Republican Union members, and the House, which has 21 members, has 14 democrats to 7 Republican Union. The receipts into the State Treasury, for the year ending January 1, 1862 (the last published), were \$97,810.50, and the expenditures for the same period were \$76,414.04, of which \$38,989.05 were for general purposes, and \$37,423.99 for education. The State has no debt, but possesses a general fund of \$771,750, and a school fund of \$431,892. The census valuation of the State in 1860 was \$46,242,181. The assessors' valuation in 1862, which omits all property exempt from taxation, was \$41,521,498. The total taxes of the State were \$121,121.36. There are 14 banks in the State, which in May, 1862, had an aggregate capital of \$1,915,010, a circulation of about \$1,000,000, and \$250,000 in specie. Small as is the territory of the State, it has 137 miles of railroad, which cost for road and equipment \$4,312,129; and one canal, the Chesapeake and Delaware, 12.63 miles in length, and having a width and depth sufficient for the passage of vessels drawing 9 ft. of water. The cost of construction of this canal was \$3,547,561.

The State has two colleges, St. Mary's (Catholic) at Wilmington, and Delaware College (Protestant) at Newark. The preparatory depart-

ment only of the latter is now in operation. There are 296 public schools in the State. In 1861, 15,036 children attended the schools, which were maintained an average period of 6.97 months. The whole amount expended for school purposes was \$85,333.08. Of this sum \$33,359.49 was derived from the school fund and \$53,485.08 was raised by contribution, and of this \$37,731.80 (more than two thirds) was raised in New Castle county. The income of the general school fund is distributed to the counties, according to their population in 1830, and the income of the U. S. surplus fund equally to each county. By this arrangement New Castle county, which has 54,796 inhabitants, receives \$12,807.36, and Sussex county, which has only 29,615 inhabitants, receives \$12,011.22.

The constitution of the State provides that each county shall have an equal number of Senators and Representatives in its Legislature; a provision fair enough when the constitution was adopted, since at that time the counties varied little in population; but now manifestly unjust, since the population of New Castle county is very nearly double that of either of the other two counties.

According to the census report of 1860, there are in the State 90,589 white inhabitants, 19,827 free colored, and 1,798 slaves. Of the slaves 1,341 (three fourths) are in Sussex county, 254 in New Castle and 203 in Kent; of the free colored, 8,188 are in New Castle, 7,271 in Kent, and 4,370 in Sussex; of the whites, New Castle has 46,355, Sussex 23,904, and Kent 20,330. The aggregate manufactures of the State were \$9,920,000, and consisted principally of shipping, flour and meal, steam engines and machinery, railroad cars, carriages, lumber, cotton and woollen goods, and boots and shoes. The war has greatly increased the productive industry of Wilmington, the principal city of Delaware, several of the iron clad and other gunboats having been built there, and the demand for locomotives and cars having been much greater than at any previous period. The cash value of the farms of the State was \$31,426,357, which, taking into account the small amount of territory in the State, was as high as most of the other States. Great attention has been paid to fruit growing in the State, and its peach and apple orchards, supply a large part of the demand in the neighboring cities of Philadelphia and Baltimore. The wheat of Delaware has a high reputation, and the flour from its mills is in demand and brings high prices. The State raised its quotas for the volunteer army under the calls of July and August, 1862, without a resort to drafting. In all about 5,000 men have been furnished by the State.

DIPLOMATIC CORRESPONDENCE OF THE UNITED STATES IN 1862. The correspondence of the Federal Governments with

foreign governments during 1862 was more voluminous than during the preceding year, and embraces some interesting and important subjects arising out of the unusual state of affairs.

*Great Britain.*—As early as November, 1861, the action of the British Consul at Charleston, Mr. Bunch, became a subject of complaint by the Federal Government. This action consisted in communicating, under instructions from home, to the Confederate authorities the desire of her Majesty's Government that the second, third, and fourth articles of the declaration of Paris should be observed by the Confederate States in the prosecution of the hostilities in which they were engaged. The grounds alleged for complaint against this action of the Consul by the Federal Government were, that a statute of the United States forbids, under a heavy penalty, any person not specially appointed, or duly authorized or recognized by the President, whether citizen or denizen, privileged or unprivileged, from counselling or advising, aiding or assisting in any political correspondence with the Government of any foreign state whatever, with an intent to influence the measures of any foreign Government, or of any officer or agent thereof, in relation to any disputes or controversies with the United States, or to defeat the measures of their Government. The conduct of Mr. Bunch was thus taken to be a wanton violation of the law of the United States, and its Government announced, as the result of the most calm and impartial deliberation, a necessity put upon it to revoke the exequatur of the Consul.

The reply of Earl Russell was, that the United States Government, by quoting this statute as the foundation on which to rest their complaint, seemed distinctly to admit that the Government of the Confederate States at Richmond was, as regards the United States, "the government of a foreign state"—an admission which goes further than any acknowledgment with regard to those states which her Majesty's Government had hitherto made. And if the Confederate States are, as regards the United States, a foreign state, which is implied by the grounds taken by the latter, then the President of the United States has no competence one way or the other, with respect to the functions of the Consuls of other Governments in that foreign state, and the exequaturs of such Consuls can be granted or withdrawn only by the government of such foreign state. The Confederate States cannot be at one and the same time "a foreign state," and part of the territory of the United States.

It had been further asserted by the United States Government that any communication to be addressed to the Government of the Confederate States respecting goods of a belligerent on board of neutral ships, &c., should have been made by diplomatic and not by consular agents, and the only authority in the United States to receive such a communication was the Government of the United States itself.

To this assertion Earl Russell replies, that it is gravely telling her Majesty's Government that an application to the Confederate Government for redress ought to be made through the President of the United States. Her Majesty's Government may well ask whether such a position is seriously laid down, and whether the President of the United States can affirm that, in the present condition of things, he has the power to give effect to any such application which might be made to him. Could the President of the United States restore a British subject impressed into the Confederate service, or could he recover private debts due a British subject and confiscated under a Confederate or State law? It is then declared by Earl Russell to be a principle of international law, that when the persons or property of the citizens or subjects of a state are injured by a *de facto* government, the state so aggrieved has a right to claim from the *de facto* government redress and reparation. It may be necessary in future, for the protection of the interests of her Majesty's subjects, to have further communications both with the central authority at Richmond, and with the governors of the separate states, and in such cases communications will continue to be made, but such communications will not imply any acknowledgment of the Confederates as an independent state.

Mr. Adams, in reply, expressed astonishment that he should have given any justification of the view of the statute taken by Earl Russell through ambiguity in his previous communications, and proceeded to explain that the statute was designed to punish all persons, whether native or foreign, citizen or privileged, who knowingly made themselves instruments of foreign states to foment factious disturbances within the United States. In applying the law in a mitigated form to Mr. Bunch, he could not have made so great a mistake as to have assumed that he was dealing with "the government of a foreign state."

Respecting the other position taken by him, namely, that the Government was the only authority to which any diplomatic communication could be made, he urged that otherwise every proceeding was an attempt to undermine the authority to which an agent had been accredited, by his recognizing for any purpose the validity of a domestic antagonism within the limits of that authority. Other arguments were advanced by Mr. Adams, but the subject appears to have then been dropped. More than a year afterward, when an attack on Charleston was about to be made, the British war steamer *Cadmus* entered that port and took away Mr. Bunch.

The next subject of discussion with her Majesty's Government arose from reports received by the Navy Department, that although the United States had a deposit of coal at Nassau, the Federal steamers were denied the right of taking it for use by the colonial authorities at that place. On the 24th of Feb., Mr. Adams

addressed a letter to Earl Russell stating the disbelief of the President that these proceedings had been sanctioned by her Majesty's Government, but if they had been, he requested such action in the proper quarter as might lead to a rectification of the error.

On the 25th of March, Earl Russell replied that coal had arrived at Nassau in the schooners *Stetson* and *Perry*, which could hardly be described as a deposit of coal existing at Nassau, although it was doubtless the coal referred to. On the arrival of the *Stetson*, the coal appeared by the vessel's papers to have been shipped by the Navy Department. The governor therefore gave directions that the coal should be admitted to an entry and landing, but that the United States Consul should be informed that it could not be permitted to be used in any manner which might involve a breach of the Queen's proclamation of the 18th of May, 1861, and particularly that the coaling at Nassau of vessels of war of either of the belligerent powers could not be allowed without the express sanction of her Majesty's Government having been first obtained. Meantime the *Perry* arrived, laden with coal. On the 11th of Dec. the U. S. war steamer *Flambeau* arrived, and on the next day the American Consul applied for permission to land the cargo of the *Stetson*, as she was leaking badly, or to discharge a part of it on board the *Flambeau*. Permission was given to him to land the coal, but not to tranship it to the *Flambeau*. The coal was not however landed. The Consul then complained that the Confederate vessel *Theodora* had been supplied with coal by a merchant, to which the governor, in reply, said, that the *Theodora* was a merchant vessel trading to the port at Nassau, and that being propelled by steam, it was necessary, to enable her to pursue her occupation as a trader, that she should be supplied with coal. The furnishing this necessary article, therefore, for her use by a merchant in the way of trade, was perfectly lawful, and could not be construed into a breach of neutrality. On the other hand, the *Flambeau* was avowedly an armed vessel in the service of the Federal Government. To supply her with coal might facilitate her belligerent operations, and this would constitute an infraction of the neutrality prescribed by the Queen's proclamation. The object of the authorities at Nassau was to preserve a strict neutrality, and her Majesty's Government could not therefore withhold from the governor the approval to which he was entitled for the course which he had pursued.

It was also pointed out that the cases of the *James Adger* and the *Nashville* at Southampton were not parallel cases. Those vessels were some thousands of miles distant from their respective homes, and to them, consequently, coal was an article of real necessity; whereas the *Flambeau* was within a very short distance of the ports of her own nation, Key West, for instance, where her necessities could

readily be supplied. The application of the United States Consul was not founded on the necessities of the *Flambeau*, but on the alleged necessities of the *Stetson*. The view taken of this decision is thus stated by Mr. Seward in a despatch to Mr. Adams, dated April 16: "The approval of the British Government of the proceedings of the governor of Nassau is regarded by the President as unfriendly toward a power that extends unrestricted hospitalities to the naval as well as the mercantile marine of Great Britain in its ports and harbors. The grievance is not sensibly alleviated by the fact that the Government of her Majesty are able to reconcile it with a proclamation issued by her Majesty in May last, conceding the rights of a belligerent to the insurgents in arms against the United States. The explanation obliges us to renew the declaration this Government has so often made, that it regards the proclamation itself as unnecessary, unfriendly, and injurious."

The next subject of interest related to the preparation of the steam gunboat *Oreto*, which has subsequently appeared as a cruiser of the Confederate navy. On the 18th of February, Mr. Adams writes to Earl Russell that he had been informed of the preparation at Liverpool of an armed steamer, evidently intended for hostile operations on the ocean. In reply, Earl Russell stated that the commissioners of the customs at Liverpool reported that she was built for certain parties in Liverpool, and intended for the use of Thomas, Brothers, of Palermo, one of whom had frequently visited the vessel during the process of building—that she had taken nothing on board but coal and ballast—that she was not fitted for the reception of guns; nor were the builders aware that she was to be supplied with guns whilst she remained in England, and the collector at Liverpool stated that he had every reason to believe that the vessel was for the Italian Government—also that special directions had been given to the officers at Liverpool to watch the movements of the vessel. Mr. Adams subsequently writes to Mr. Seward—"the nominal destination of the *Oreto* to Sicily is the only advantage which appears to have been derived from my attempt to procure the interference of the Government to stop her departure."

On the 25th of March, Mr. Adams writes again to Earl Russell, enclosing a letter from the American Consul at Liverpool, stating certain facts relative to the *Oreto*. Mr. Adams says: "It is with great reluctance that I am driven to the conviction that the representations made to your lordship of the purposes and destination of that vessel were delusive, and that though at first it may have been intended for service in Sicily, yet that such an intention has been long since abandoned in fact, and the pretence has been held up only the better to conceal the true object of the parties engaged. That object is to make war on the United States. All the persons thus far known to be most connected with the undertaking are either

directly employed by the insurgents in the United States of America, or residents of Great Britain, notoriously in sympathy with, and giving aid and comfort to them on this side of the water."

On the 8th of April, Earl Russell replied to Mr. Adams, enclosing a report from the Lords Commissioners of her Majesty's treasury, which states that the *Oreto* was registered on the 3d of March in the name of John Henry Thomas, of Liverpool, as sole owner, that she cleared on the following day for Palermo and Jamaica in ballast, but did not sail until the 22d, having a crew of fifty-two men, all British with the exception of three or four, one of whom was an American. She had no gunpowder, nor even a signal gun, and no colors save *Marryatt's* code of signals and a British ensign, nor any goods on board excepting the stores enumerated in an accompanying copy of her victualling bill.

On the 15th of April, a conference took place between Mr. Adams and Earl Russell. Its close is thus stated by the former:

In the case of the *Oreto*, upon which I had addressed a note to him, he had directed an investigation to be made, and the authorities at Liverpool had reported that there was no ground for doubting the legality of her voyage.

I replied that this was exactly what gave such unpleasant impressions to us in America. The *Oreto*, by the very paper furnished from the custom-house, was shown to be laden with a hundred and seventy tons of arms, and to have persons called troops on board, destined for Palermo and Jamaica. The very statement of the case was enough to show what was really intended. The fact of her true destination was notorious all over Liverpool. No commercial people were blind to it. And the course taken by her Majesty's officers in declaring ignorance only led to an inference most unfavorable to all idea of their neutrality in the struggle. It was just such action as this that was making the difficulties of our Government in the way of giving the facilities to the supply of cotton, which they hoped to furnish in a short time if the whole control of means to put an end to the contest was left to them.

His lordship concluded by a polite expression of regret at these circumstances, at the same time that he could not see how the Government could change its position.

The assertion of Mr. Adams relative to troops &c. is not sustained by the copy of the paper from the custom house contained in this volume of documents. The only part referring to troops and guns is as follows:—

"Men, 52; passengers or troops, —; guns, —; 178 tons."

Again, on the 26th of June, Mr. Seward writes to Mr. Adams that a gunboat called the *Oreto*, built in England for the service of the insurgents, with ports and bolts for twenty guns, and other equipments, arrived at Nassau; and that the United States Consul, on the basis of the facts relative to her, made a protest upon the subject and she was seized by the authorities. She was, however, released soon after, on the arrival at Nassau of Capt. Semmes, late of the *Sumter*, and was about to start on a privateering cruise. This release by the authorities of Nassau, Mr. Seward was instructed by the Pres-

ident to protest against, as it seemed to be particularly at variance with her Majesty's proclamation of neutrality—and to ask the consideration of her Majesty's Government upon the proceeding as one calculated to alarm the Government and people of the United States. The subject was duly brought to the notice of Earl Russell, who, on the 29th of August, replied that the *Oreto* had been seized at Nassau, and was to be tried before the admiralty court for a breach of the foreign enlistment act. This was accompanied by the statements of the collector, surveyor and inspector of the port of Liverpool, and the affidavit of the pilot, that the vessel, when she went to sea, had no munitions of war in her, that is guns, carriages, shot, shell, or powder.

No further reference is made to the *Oreto* in this correspondence, but the 290, or *Alabama*, is introduced as a more formidable object. On the 23d of June, Mr. Adams writes to Earl Russell, saying:—"I am now under the painful necessity of apprising your lordship that a new and still more powerful war steamer is nearly ready for departure from the port of Liverpool on the same errand as the *Oreto*. This vessel has been built and launched from the dockyard of persons, one of whom is now sitting as a member of the House of Commons, and is fitting out for the especial and manifest object of carrying on hostilities by sea." Accompanying this was a letter from the United States Consul at Liverpool in confirmation of these and other statements.

The subject was immediately referred to the Lords Commissioners of her Majesty's treasury, who, on the 1st of July, report that the fitting out of the vessel had not escaped the notice of the revenue officers, but that as yet nothing had transpired concerning her which had appeared to demand a special report. The vessel was intended for a ship of war, reported to be built for a foreign government, but as yet had neither guns nor carriages on board, and the builders did not appear disposed to reply to any questions respecting the destination of the vessel after she left Liverpool. Their solicitor, however, reported his opinion that there was not at that time sufficient ground to warrant the detention of the vessel, or any interference by the department. The Consul at Liverpool was then instructed by Mr. Adams to lay his evidence before the Commissioners. At the same time, he called Capt. Craven, in command of the U. S. gunboat *Tuscarora*, to Southampton. To Capt. Craven was given all the information respecting the objects and destination of the 290 in possession of Mr. Adams, who advised him to take such measures as might in his opinion be effective to intercept her on her way out.

Meanwhile evidence was procured of the character and objects of the vessel by the U. S. Consul at Liverpool, which, in the opinion of a Queen's solicitor, was sufficient to justify the collector of the port in seizing the vessel, and

laid before the commissioners. While the subject was under their consideration the 290 sailed from Liverpool, without register or clearance. The captain of the *Tuscarora* was immediately notified by Mr. Adams and he started in pursuit. Earl Russell, in a conference with Mr. Adams, stated that a delay in determining upon the case had most unexpectedly been caused by the sudden development of a malady of the Queen's advocate, Sir John D. Harding, totally incapacitating him for the transaction of business. This had made it necessary to call in other parties, whose opinion had been at last given for the detention of the gunboat, but before the order got down to Liverpool the vessel was gone. He should however send directions to have her seized if she went, as was probable, to Nassau. Instructions were also despatched to Ireland to detain the vessel, if she put in to Queenstown.

On the 30th of Sept. Mr. Adams wrote to Earl Russell, relating the injuries done by the 290 or *Alabama*, saying, "I have strong reasons to believe that still other enterprises of the same kind are in progress in the ports of Great Britain at this time. Indeed they have attained so much notoriety, as to be openly announced in the newspapers of Liverpool and London." Earl Russell, acknowledging the letter, in reply said: "I have to state to you that, much as her Majesty's Government desire to prevent such occurrences, they are unable to go beyond the law, municipal and international."

On the 9th of October Mr. Adams enclosed to Earl Russell the following intercepted letter, "as substantiating the allegations made of the infringement of the enlistment law by the insurgents of the United States in ports of Great Britain." He also added: "In the representations which I have had the honor lately to make, I beg to remind your lordship that I base them upon evidence which applies directly to infringements of municipal law itself, and not to anything beyond it."

CONFEDERATE STATES OF AMERICA, }  
NAVY DEPARTMENT, RICHMOND, July 12, 1862. }

SIR: Your letter of the 29th of March last reached me this morning.

The department notified you, on the 11th of January last, that you would receive orders to command the second vessel then being built in England, but for reasons satisfactory to the department, you were subsequently assigned to the command of the first vessel, the *Florida* (*Oreto*), now at Nassau, and any just ground for "the surprise and astonishment" in this respect at the department's action is not perceived.

A commission as commander for the war was sent you on the 5th of May, and your failure to follow the *Oreto*, which left England about the 21st of March, and to take command of her, as was contemplated, and as you were apprised by Captain Bullock, on the 26th of March, is not understood, and has been productive of some embarrassment.

Captain Bullock was nominated by the executive for his position in the navy under existing law, and was duly confirmed by the Senate, and your protest to this department against the action of these coordinate branches of your government is out of place.

Upon the receipt of this letter you will turn over to Lieutenant G. F. Sinclair the instructions which you

may have received, together with any public funds in your hands, and return to the Confederate States in such manner as your judgment may direct.

Should you not be provided with funds for this purpose, Commander Bullock will, upon your application, supply them.

I am, respectfully, your obedient servant,  
S. H. MALLORY, Secretary of the Navy.  
Commander Jas. H. NORTH,  
C. S. N., London, England.

On the 16th of October Mr. Adams writes home to Mr. Seward that, "It is very manifest that no disposition exists here to apply the powers of the Government to the investigation of the acts complained of, flagrant as they are, or to the prosecution of the offenders. The main object must now be to make a record which may be of use at some future day."

Among the papers laid before Earl Russell by Mr. Adams was an affidavit of a person who sailed from Liverpool in the 290, stating that arms were furnished to her in or near Augra Bay, part of the Azores. To which Earl Russell replies that the transaction does not appear to have taken place in any part of the United Kingdom, or of her Majesty's dominions, but in part of the Portuguese dominions. No offence, therefore, cognizable by the laws of the country, appears to have been committed by the parties engaged in the transaction. Respecting a statement in a letter of the American consul at Liverpool, that a bark was to take out a cargo of coals, either from Cardiff or Troon, near Greenock, for the 290, Earl Russell replies that "there would be great difficulty in ascertaining the intention of any parties making such a shipment; and we do not apprehend that our officers would have any power of interfering with it, were the coals cleared outward for some foreign port in compliance with the law." No further correspondence relative to the 290 and the *Oreto* took place. (*See NAVY, CONFEDERATE.*)

The discussions between the two Governments relating to these vessels were also extended to the subject of furnishing supplies to the Confederate States by means of vessels fitted out in English ports to run the blockade. On the 11th of March, Mr. Seward wrote to Mr. Adams that information had been received that insurance companies in England were insuring vessels engaged in running the blockade, and even vessels carrying contraband of war. This, he said, "was, in effect, a combination of British capitalists, under legal authority, to levy war against the United States. It is entirely inconsistent with the relations of friendship, which we, on our part, maintain toward Great Britain." Earl Russell, in reply to the representations of Mr. Adams, said:—"The matter shall have the due consideration of her Majesty's Government." On the 25th of March, Mr. Adams writes to Earl Russell as follows:

It is obvious that just in proportion to the success of the efforts made by the ill-intentioned people of foreign countries to violate the blockade must be the endeavors to enforce it with increased stringency. So, also, in proportion to the success of such persons in

supplying, by violation of law, the insurgents with the means of continuing their resistance, must be the delay in restoring to all honest people the customary facilities of trade and intercourse to which they are justly entitled. It has not been without great regret that the Government has been compelled to observe the extent to which her Majesty's flag has been abused to subserve the purposes of the disaffected, and thus to continue the present depressed condition of legitimate trade. A very great proportion of the vessels which attempted to violate the blockade appear to be fitted out directly from Great Britain, or some of her dependencies. The effect of permitting such violations of good faith to go unnoticed by Government is not merely to create an unfortunate degree of irritation in America, implicating many far beyond the sphere of the unworthy parties concerned in producing it, but to postpone proportionately the prospect of bringing about a better state of things. It is for this reason, as well as from a desire earnestly felt by the President to maintain unbroken all the customary relations of amity with Great Britain, that I have been directed to make the present representation. Any suggestion of the means best adapted to remedy the evils complained of is deemed a matter exclusively within the competency of those in whom the decision to act is vested.

On the 27th, Earl Russell replied as follows :

The charge that nearly all the assistance now obtained from abroad by persons still in arms against the Government of the United States, and which enables them to continue the struggle, comes from Great Britain and its dependencies, is somewhat vague. I believe the greater part of the arms and ammunition sent from this country to America during the struggle has gone to the United States.

I agree with you in the statement that the duty of nations in amity with each other is not to suffer their good faith to be violated by ill-disposed persons within their borders, merely from the inefficiency of their prohibitory policy. But it is, at the same time, a duty not to punish persons on suspicion, without any proof of their evil intent. It is not the custom of this country to deprive any person of liberty or property without evidence of some offence. If such evidence can be obtained, the laws are sufficient to prevent the accomplishment of their evil designs against friendly nations.

You have not yourself hitherto furnished me with evidence that any vessel has received a hostile or warlike equipment in British waters, which has been afterwards used against the United States. The care that was taken to prevent the warlike equipment of the Nashville in British waters must be familiar to your recollection.

With regard to coöperation with the policy of the United States in respect to the blockade, I must remind you that Great Britain has abstained, as far as possible, from complaints of the irregularity of the blockade which has been instituted.

Her Majesty's government have been mindful of the suddenness of the danger with which the United States were threatened; of the inadequacy of the naval force then at the disposal of the Government, and of the great difficulty of blockading a coast of three thousand miles. But beyond forbearance and a liberal interpretation of the law of nations in favor of the United States, her Majesty's Government cannot go. If by coöperation with the policy of the United States is meant either taking part in the civil war still raging, or imposing restraints on the Queen's subjects unknown to international law, I cannot undertake that her Majesty's Government will adopt either of those courses. It would be an unheard-of measure to prohibit merchants from sending ships to sea destined to the Southern ports. Should such ships attempt to violate the blockade, capture and condemnation are the proper penalty of such attempts. No authority can be found for any other.

On the 4th of April, Mr. Seward again re-

quests Mr. Adams to bring the subject to the notice of Earl Russell, "in the hope that the time may have at last come when British subjects, deliberately and wickedly engaged as abettors in the existing warfare against the Government, may be subjected to some restraint, or, at least, be made to feel Her Majesty's severe displeasure." In reply to these views presented by Mr. Adams, on the 15th of April, Earl Russell expressed his belief that the parties engaged in these undertakings were not so much interested in the cause of the insurgents as in the profits to be expected by running the blockade. Such attempts always would be made in similar cases. For the rest, these adventurers were compelled to take their own risk. They had the dangers of capture to encounter, and the certainty of being deprived of their rights of reclamation. The Government had no disposition to give them protection.

On the 25th of April, Mr. Adams writes to Mr. Seward: "Meantime outfits of vessels with supplies to run the blockade go on with increased vigor. Every account received of a successful voyage stimulates to enlarged contributions."

In a letter, on the 30th, to Earl Russell, Mr. Adams refers to the subject again, saying :

I deem it my duty to represent to your lordship the fact that the Government of the United States finds itself involved in peculiar embarrassment in regard to its policy toward the vessels of Great Britain, from the difficulty, to which I have repeatedly called your lordship's attention, of distinguishing between the lawful and the unlawful trade carried on upon the coast of the United States in vessels bearing her Majesty's flag. It comes presented to me in so many forms of evidence, that I cannot avoid the painful conviction that a systematic plan, founded on the intent to annul her Majesty's proclamation by steady efforts to violate the blockade through vessels either actually British, or else sailing under British colors, has been in operation in this island for many months, and becomes more rather than less extensive with the progress of time.

To this letter Earl Russell emphatically replied on the 6th of May, in these words :

With regard to the "systematic plan" which you say has been pursued by her Majesty's subjects "to violate the blockade by steady efforts," there are some reflections which I am surprised have not occurred to you.

The United States Government, on the allegation of a rebellion pervading from nine to eleven States of the Union, have now for more than twelve months endeavored to maintain a blockade of three thousand miles of coast. This blockade, kept up irregularly, but when enforced, enforced severely, has seriously injured the trade and manufactures of the United Kingdom. Thousands of persons are now obliged to resort to the poor rate for subsistence, owing to this blockade. Yet her Majesty's Government have never sought to take advantage of the obvious imperfections of this blockade, in order to declare it ineffective. They have, to the loss and detriment of the British nation, scrupulously observed the duties of Great Britain toward a friendly state. But when her Majesty's Government are asked to go beyond this, and to overstep the existing powers given them by municipal and international law for the purpose of imposing arbitrary restrictions on the trade of her Majesty's subjects, it is impossible to listen to such suggestions. The ingenuity of persons engaged in commerce will always, in some degree, defeat attempts to starve or debar from commer-

cial intercourse an extensive coast inhabited by a large and industrious population.

If, therefore, the Government of the United States consider it for their interest to inflict this great injury on other nations, the utmost they can expect is that European powers shall respect those acts of the United States which are within the limits of the law. The United States Government cannot expect that Great Britain should frame new statutes to aid the Federal blockade, and to carry into effect the restrictions on commerce which the United States, for their own purposes, have thought fit to institute, and the application of which it is their duty to confine within the legitimate limits of international law.

Two days later Mr. Adams responded as follows :

In declaring that blockade the Government of the United States are believed to have done nothing which has not been repeatedly done heretofore, and the right to do which at any time hereafter, whenever the necessity shall appear to call for it, is not distinctly affirmed by the Government of Great Britain. Neither does the fact that this proceeding pressed with the greatest severity upon the interests of neutral nations appear formerly to have been regarded in any other light than as an incidental damage, which, however much regretted in itself, unavoidably follows from the gravity of the emergency which created it. For it can scarcely be supposed that so onerous a task as a veritable blockade will be undertaken by any nation for causes not deemed of paramount necessity, or will be persevered in one moment longer than those causes continue to operate. I am very sure that it is the desire of the Government of the United States to accelerate the period when the blockade now in operation may be safely raised. To that end it is bending all its efforts. And in this it claims to be mindful, not simply of the interests of its own citizens, but likewise of those of all friendly nations. Hence it is that it views with deep regret the strenuous efforts of evil disposed persons in foreign countries, by undertakings carried on in defiance of all recognized law, to impair, so far as they can, the efficacy of its measures, and in a corresponding degree to protract the severity of the struggle. Hence it is, likewise, that it has been profoundly concerned at the inefficacy of the laws of Great Britain, in which a large proportion of the undertakings originate, to apply any adequate policy of prevention. For I doubt not your lordship will see at a glance the embarrassment in which a country is necessarily involved by complaints raised of the continued severity of a blockade by a friendly nation, which at the same time confesses its inability to restrain its subjects from stimulating the resistance that necessitates a continuance of the very state of things of which they make complaint.

That a sense of the difficulties consequent upon the action of such persons prompted the enactment of the statute of his Majesty George the Third, of the 3d July, 1819, is made plain by the language of its preamble. It is therein stated that it was passed because the laws then in force were not sufficiently effectual to prevent the evil complained of. It now appears from the substance of the representations which I have heretofore had the honor to make to your lordship, that the provisions of that law are as little effectual in curing the evil as those of any of its predecessors. But I am pained to be obliged to gather from the concluding words of your lordship's note that the expression of an opinion that the United States, in the execution of a measure conceded to be correct, as well as justified by every precedent of international law as construed by the highest British authorities, cannot expect that Great Britain should frame new statutes to remedy the deficiency of its own laws to prevent what it acknowledges on the face of that statute to be evils created by its own refractory subjects. I must be permitted to say, in reply, that, in my belief, the Government of the United States would scarcely be disposed to make a similar

reply to her Majesty's Government were the relative position of the two countries to be reversed.

Permit me, in conclusion, to assure your lordship that the grounds upon which the representations I have had the honor to make [were founded] have not been hastily considered. So far from it, the extent of the evil complained of has been under rather than overstated. I have now before me a list of eleven steamers and ten sailing vessels that have been equipped and despatched within thirty days, or are now preparing, freighted with supplies of all kinds for the insurgents from one port of Great Britain alone. These supplies, I have reason to believe, are to be conveyed to Nassau, which place is used as an entrepot for the convenience of vessels under British colors, employed for the sole purpose of breaking the blockade. I have reasons for supposing that the business is reduced to a system, emanating from a central authority situated at London; and, further, that large sums of money have been contributed by British subjects to aid in carrying it on. If the United States have, in any of their relations with her Majesty's Government, committed some act not within the legitimate limits of international law which justifies the declaration of a disposition not to provide against such obvious violations of the neutrality proclaimed at the outset of this deplorable struggle, I trust I may be so clearly presented to their consideration by your lordship as to supply the means either of explanation or of remedy.

On the 10th of May, Mr. Adams, writing relative to the case of the Emily St. Pierre, hereafter mentioned, argued the duty of the Government to suppress these attempts to send supplies to the Confederate States, from the intention of the queen's proclamation. (*See ANNUAL CYCLOPEDIA, 1861; PUBLIC DOCUMENTS.*) Earl Russell immediately replied as follows :

FOREIGN OFFICE, May 10, 1862.

SIR: In the letter I had the honor to receive from you yesterday you appear to have confounded two things totally distinct:

The foreign enlistment act is intended to prevent the subjects of the crown from going to war when the sovereign is not at war. Thus private persons are prohibited from fitting out a ship-of-war in our ports or from enlisting in the service of a foreign state at war with another state, or in the service of insurgents against a foreign sovereign or state. In these cases the persons so acting would carry on war, and thus might engage the name of their sovereign and of their nation in belligerent operations. But owners and masters of merchant ships carrying warlike stores do nothing of the kind. If captured for breaking a blockade or carrying contraband of war to the enemy of the captor, they submit to capture, are tried, and condemned to lose their cargo. This is the penalty which the law of nations has affixed to such an offence, and in calling upon her Majesty's Government to prohibit such adventures you in effect call upon her Majesty's Government to do that which it belongs to the cruisers and the courts of the United States to do for themselves.

There can be only one plea for asking Great Britain thus to interpose. That plea is, that the blockade is in reality ineffective, and that merchant ships can enter with impunity the blockaded ports. But this is a plea which I presume you will not urge. Her Majesty's Government have considered the blockade as an effective blockade, and have submitted to all its inconveniences as such.

They can only hope that, if resistance should prove to be hopeless, the Confederate States will not continue the struggle; but if, on the other hand, the restoration of the Union should appear to be impossible, the work of devastation now going on will cease.

Her Majesty's Government can only desire the prosperity of the inhabitants of the United States, whatever may be the event of the present civil war.

Mr. Adams's answer was dated on the 12th, as follows:

LEGATION OF THE UNITED STATES, LONDON, }  
May 12, 1862. }

MY LORD: I have the honor to acknowledge the reception of your note of the 10th instant. From the purport of it I am led to fear that I may have been unfortunate heretofore in my attempts to express my own meaning. If I have appeared to your lordship to confound two things so very dissimilar as the penalties of the enlistment act and the liabilities which follow from the attempt to break a blockade, I can only say that the fault must be laid to my want of ability to use words properly to express my thoughts.

The position which I did mean to take was this: that the intent of the enlistment act, as explained by the words of this preamble, was to prevent the unauthorized action of subjects of Great Britain, disposed to embark in the contests of foreign nations, from involving the country in the risk of a war with these countries. This view of the law does not seem to be materially varied by your lordship; when speaking of the same thing you say that the law applies to cases where "private persons so acting would carry on, and thus might engage the name of their sovereign and of their nation in belligerent operations." It is further shown by that preamble that that act was an additional act of prevention, made necessary by experience of the inefficiency of former acts passed to effect the same object.

But it is now made plain that whatever may have been the skill with which this latest act was drawn, it does not completely fulfil its intent, because it is very certain that many British subjects are now engaged in undertakings of a hostile character to a foreign state which, though not technically within the strict letter of the enlistment act, are as much contrary to its spirit as if they levied war directly. The measures embrace all of the operations preliminary to openly carrying on war—the supply of men, and ships, and arms, and money to one party in order that they may be the better enabled to overcome the other, which other is in this case a nation with which Great Britain is now under treaty obligations of the most solemn nature to maintain a lasting peace and friendship. The Government of the United States having, in the course of its hostile operations, had occasion to experience the injurious effects of this virtual levying of war against itself from the ports of a friendly power, and seeing the obstacle in the way of the removal of them to be alleged to be the inefficiency of a statute intended to effect that object, does not regard it as asking anything unreasonable, or more than it would in like case be willing itself to grant if it solicits some action to render effective the spirit as well of the law as of her Majesty's enunciation of the national will.

I perceive that your lordship appears to be of opinion that, in this proceeding, the Government of the United States is asking more than is reasonable. It is, in your view, sufficient to declare that owners and masters of merchant ships, fitted out with intent to break a blockade or carry contraband of war to one of two parties engaged in war, are subject to capture, trial, and condemnation, if caught by the offended party. And hence, in this case, that the Government of the United States, in calling upon her Majesty's Government to prohibit such adventures, is in effect calling upon it to do that which it ought to do for itself. The only valid plea, your lordship remarks, for asking interposition, is, that the blockade is in reality ineffective; and this, you very justly presume, I shall not be disposed to urge.

But I pray your lordship's pardon if I submit that you appear to have entirely overlooked another plea, which I am confident enough to imagine of no inconsiderable weight. That plea is that the kingdom of Great Britain endeavor in spirit as well as in letter to preserve the principle of neutrality, if not of friendship, toward a foreign power in amity with it to which it has pledged itself. The precise mode in which that

shall be done, it does not presume to prescribe. That the toleration of such conduct in subjects of Great Britain, as I have had the pain heretofore to expose, is surely in violation of that neutrality, is justly to be inferred from the very language of her Majesty's proclamation. For it is therein declared that precisely such acts of theirs as I have been compelled to complain of are done "in derogation of their duty to her as a neutral sovereign, and incur her high displeasure." If such, then, be the true character of the proceedings to which I have heretofore called your lordship's attention, they surely merit something more of notice from her Majesty's ministers than an intimation that they will be suffered to pass unproved unless the punishment shall be inflicted by the nation whom they are designed to injure. The object of the Government of the United States has not been to relieve itself of the duty of vigilance to capture offenders against the law. It has rather been to avoid the necessity of applying additional stringent measures for their own security against British subjects found to be engaged in such illicit enterprises, made imperative by the conviction that no preventive coöperation whatever can be expected from her Majesty's Government. It has rather been to avoid the risk of confounding the innocent with the guilty, because all happen to be involved in a general suspicion. And, lastly, it has rather been to remove, at as early a day as may be, consistently with its own safety, the restrictions on the trade with foreign countries, which these evil-doers are laboring with so much industry to force it to protract. Your lordship's language leaves me little hope of any coöperation of her Majesty's Government to these ends. Nevertheless, I trust I may be permitted to indulge the belief that the time is not now far distant when the difficulties thus interposed in the way of its progress will have been so far removed by its own unassisted action as to relieve both countries from the painful necessity of further continuing the discussion.

The correspondence on this subject was closed by the following note from Earl Russell to Mr. Adams:

FOREIGN OFFICE, May 17, 1862.

SIR: I do not wish to prolong this correspondence, and shall only make one remark in answer to your last letter.

If the British Government, by virtue of the prerogative of the crown or by authority of parliament, had prohibited and could have prevented the conveyance in British ships of arms and ammunition to the Confederate States, and had allowed the transport of such contraband of war to New York and to other Federal ports, her Majesty's Government would have departed from the neutral position they have assumed and maintained.

If, on the other hand, her Majesty's Government had prohibited and could have prevented the transport of arms and ammunition to both the contending parties, they would have deprived the United States of a great part of the means by which they have carried on the war. The arms and ammunition received from Great Britain, as well as from other neutral countries, have enabled the United States to fit out the formidable armies now engaged in carrying on the war against the Southern States, while by means of the blockade established by the Federal Government, the Southern States have been deprived of similar advantages.

The impartial observance of neutral obligations by her Majesty's Government has thus been exceedingly advantageous to the cause of the more powerful of the two contending parties.

I have the honor to be, sir, your most obedient, humble servant,

RUSSELL.

CHARLES FRANCIS ADAMS.

The action of her Majesty's Government in according to the Confederate States belligerent rights, was a subject of constant correspondence. It was pressed by Mr. Seward as the most im-



portant of all the questions arising between the two Governments. Nevertheless, her Majesty's Government remained inflexible in the position which it had taken. At one time, on August 22d, Mr. Adams writes to Mr. Seward that he had been told, but not by authority such as to place the matter altogether beyond a doubt, that his (Mr. Seward's) despatch in connection with preceding ones likewise communicated, and other considerations, had had so much effect on the Ministry as to incline them to leave open a way to the revival of their former policy depending on the issue of the movement upon Richmond. Had that been successful, the recognition of belligerent rights was to have been withdrawn.

Representations were also made to her Majesty's Government, relative to the proceedings at Nassau, by parties engaged in running the blockade, but they were not successful in obtaining any interference of the Government. Representations were also made by British subjects at Liverpool, relative to a kind of blockade of the island by American cruisers. (*See BLOCKADE.*) But the Government made no concessions to the petitioners.

The case of the ship *Emily St. Pierre* was one of considerable interest. On the 24th of April, Mr. Adams wrote to Earl Russell that this ship, being under a British register, and belonging to British subjects residing in Liverpool, was found on the 18th of March previous, attempting to run into the port of Charleston, in South Carolina, in violation of the blockade, there legitimately established. She was seized, and the crew, with the exception of the commander, the steward, and cook, taken out, and a prize crew of three officers and twelve men put on board, with directions to proceed to Philadelphia. The captain being left at liberty on board, concerted a scheme by which he surprised and took possession of the vessel, and compelled the seamen to navigate the ship to the port of Liverpool, where he sent them ashore, and took shelter for himself under the authority of the British Government. Mr. Adams asked for the restoration of the vessel, on the ground that it had been decided that such an act would work a total confiscation of vessel and cargo, and that the unlawful intent of the voyage was too strongly indicated to justify the extension to it of any protection by the Government.

Earl Russell replied, on the 7th of May, that her Majesty's Government were unable to comply with the request for the restoration of the ship, inasmuch as they had no jurisdiction or legal power whatever to take or to acquire possession of her, or interfere with her owners in relation to their property in her. Further, her Majesty's Government could not raise in an English court the question of the validity of the capture of this ship, or of the subsequent rescue and recapture, for such recapture is not an offence against the municipal law of England.

On the 9th of May, Mr. Seward writes to Mr. Adams:—"Your proceeding, in asking from the British Government the restoration of the prize ship *Emily St. Pierre*, is approved, equally for its promptness and the grounds upon which it was adopted."

Mr. Adams replied to Earl Russell on the 10th of May, by quoting the opinion of Lord Stowell, as the highest judicial authority of Great Britain, as follows:—"If a neutral master attempts a rescue, he violates a duty which is imposed upon him by the law of nations to submit to come in for inquiry as to the property of the ship or cargo; and if he violates that obligation by a recurrence to force, the consequence will undoubtedly reach the property of his owner; and it would, I think, extend also to the confiscation of the whole cargo intrusted to his care, and thus fraudulently attempted to be withdrawn from the rights of war."

Mr. Adams then refers to the Queen's proclamation as warning her subjects, and all persons entitled to her protection, that if they shall presume, in contempt thereof, to do any act in derogation of their duty as subjects of a neutral sovereign, or in violation, or contravention of the law of nations in that behalf, they will incur and be liable to the several penalties and penal consequences, by statute or by the law of nations imposed. From the words of this proclamation he inferred a jurisdiction existing in Great Britain, capable of taking cognizance of cases arising under the law of nations, and beyond the range of the municipal law.

On the 12th of June Earl Russell replied by stating the principles involved in the case, and closed the correspondence on the subject as follows:

You speak of the rescue of the *Emily St. Pierre* as being a fraud by the law of nations. But whether the act of rescue be viewed as one of fraud or of force, or as partaking of both characters, the act was done only against the rights accruing to a belligerent under the law of nations relating to war, and in violation of the law of war; which, whilst it permits the belligerent to exercise and enforce such rights against neutrals by the peculiar and exceptional right of capture, at the same time leaves to the belligerent alone the duty and confers upon him the power of vindicating such rights and of enforcing such law. The same law not only does not require, but does not even permit, neutral nations to carry out belligerent rights.

You allude to the conduct of the United States Government in the case of the *Treat*; but the flagrant wrong done in that case was done by a naval officer in the service of the United States; the prisoners whose release was demanded were in the direct custody and keeping of the executive Government, and the Government of the United States had actually the power to deliver them up, and did deliver them up, to the British Government. But the *Emily St. Pierre* is not in the power of the Executive Government of this country; and the law of England, as well as the law of nations, forbids the Executive Government from taking away that ship from its legal owners.

I do not think it necessary to dwell, or even to remark, on the observations which you repeat in your present letter as to the terms of her Majesty's proclamation, and as to the course which you suggest her Majesty's Government should adopt for giving effect to them.

I can only again assure you that her Majesty's Government have been most careful in observing strictly that impartial course which neutrality enjoins.

Mr. Adams, writing to Secretary Seward on the 18th of June, says :

It is not a little strange that this very question appears to have occupied the attention of the two Governments so far back as in the year 1800. My attention has been called to this fact by my under secretary, Mr. Moran, who happened to find the correspondence on the subject in the third volume of the collection of American State papers relating to foreign affairs. It was the British Government which then made the claim on almost the identical grounds taken by me, and the American declined acceding to it, substantially for the same reasons given by Lord Russell.

One of the most important subjects of negotiation during the year was a treaty for the suppression of the slave trade. (*See PUBLIC DOCUMENTS.*) It admits, within certain limits, the search and seizure by British cruisers of vessels under the American flag supposed to be engaged in that traffic. Mr. Seward states, in his despatch to Mr. Perry at Madrid on August 2d: "It was freely offered by this Government to Great Britain, not bought, or solicited by that Government. It is in harmony with the sentiments of the American people. It was ratified by the Senate, unanimously, and afterward distinctly approved with not less unanimity by both Houses of Congress. Not a voice has been raised against it in the country." This treaty granted to Great Britain a privilege which had been inflexibly refused by the American Government since it was organized. Its exercise without permission had heretofore caused more irritated feelings in the United States against Great Britain than any other subject.

The correspondence between the two Governments during the year, amid all the embarrassing circumstances which existed, appears to have been conducted in a most friendly spirit. Her Majesty's Government seem by these papers to be actuated by no other purpose than to maintain a strict and impartial neutrality according to the law of nations between the two contending parties, and although the position assumed, to regard each as belligerents, has been considered by the Federal Government "as unnecessary and tending injuriously to prolong the war," yet her Majesty's Government have justly claimed the right to determine their own position, and have inflexibly maintained it. Apart from this point, each government has been prompt to listen to every complaint from the other, and treated it with the highest respect. Nothing appears in this correspondence to indicate that the Government of Great Britain entertains any other than the most friendly feelings toward the Government and people of the United States, and indulges the sincere desire that the bitter conflict, which is exhausting alike the North and the South, may be speedily so closed as to promote the welfare of the whole country. Still it might be asked, how the building of war steamers, and the

shipment of the munitions and supplies from Liverpool to Nassau, and thence to the Confederate States, could be consistent with the existence of such friendly feeling? Such munitions and supplies have been shipped with equal freedom to the United States. These acts are not inconsistent with a position of neutrality, and the freedom of commerce of which the construction of the ship *Great Admiral* for Russia, and the *Hudson* and others for Greece, by the United States, are examples.

*France.*—The correspondence with France represents that country as determined not to interfere with the blockade of the Confederate ports, but as exceedingly anxious for the cessation of the domestic strife. Mr. Dayton writes on the 12th of February :

The Emperor, last night, in a brief conversation held with him while at a private ball at the Tuileries, again expressed his earnest wish that our domestic strife was brought to a close. When I told him that I had sanguine hopes of success at no distant day, he asked me specially about the condition of the roads, and the possibility of turning aside from them into the open country. He referred to the great difficulty of moving wagons, cannon, and the immense materiel essential to a great army over a single road, especially in a wooded country, illustrating it forcibly, as he did, by his own troubles and perplexities in his Italian campaign.

On the 18th of March, Mr. Dayton reports a conference with M. Thouvenel, the Secretary for Foreign Affairs. "He asked again most anxiously when they should have cotton? I referred him to your despatch, and assured him of our earnest desire to afford the earliest facilities to foreign governments for the procurement of it. He said that petitions and memorials were being daily addressed to the Emperor on this subject: that the suffering and destitution in certain portions of France for want of it were constantly on the increase. Do not delay action, I beg of you, a day beyond the time that you can act on this subject with propriety."

On the 25th of March, Mr. Dayton had an interview with the Emperor. He writes, "I was most kindly received, and he said at once that he wished to have a talk with me about cotton, and the prospect of opening our ports. He spoke of the great inconvenience connected with the existing condition of things, and feared it would not speedily come to an end; that the war might yet be a long one." After explanations on these points, Mr. Dayton referred as usual on every occasion to the granting of belligerent rights to the Confederate States, saying: "I told him we honestly believed that if a proclamation by France and England, withdrawing belligerent rights from the insurrectionists, should be made, the insurrection would collapse at once." During the conversation, the Emperor declared he must frankly say when the insurrection broke out, and this concession of belligerent rights was made, he did not suppose the North would succeed; that it was the general belief of statesmen in Europe that the two sections would never come

together again. This belief, he intimated, was a principal reason why this concession of belligerent rights was then granted. The close of this conference is thus reported by Mr. Dayton: "Without expressing any opinion upon these matters, he said he would think of them, but hoped in the meantime that something would be done by us to relieve the difficulties here growing out of the want of cotton."

Mr. Seward, writing to Mr. Dayton on the 26th, says, relative to a former inquiry of the Emperor whether cotton will come: "Upon this point you may safely assure him that all apprehensions are, in our view, groundless." Mr. Seward was mistaken. The cotton did not come to any amount of importance even with the port of New Orleans open. (*See COMMERCE.*) Mr. Dayton writes on March 31st, "That (cotton) is now the great and leading point of interest between them (the French Government) and us." "The French Government has come to the conclusion, I think, that we will get possession of the cotton ports, but they seem now to be troubled with grave doubts whether, in that event, even, cotton will be forthcoming." He then relates a conference with M. Thouvenel, at which he again called his attention to the propriety of his Government's retracing its steps in regard to its concession of belligerent rights to the Confederates.

On the 22d of April, Mr. Dayton writes that M. Thouvenel had returned from a visit to the manufacturing districts, and assured him that it was painful to see the immense establishments not at work and the population unemployed; the distress was great and the demand for cotton most urgent.

On the 16th of May, Mr. Dayton writes: "Without a still further change for the better in the condition of things at home, or some encouraging information from Mr. Adams, I hesitate to urge the point further (revoking the concession of belligerent rights). It might be considered as savoring of impertunity, or, at all events, as wanting in that diplomatic forbearance which this Government would have a right to expect." He closes with a postscript, stating that a communication from Mr. Adams had just been received, which, he says, "informs me that the British Government had no intention to vary the policy adopted heretofore; and he states further, 'the answer was that the great ports were not yet in our possession, and the issue appeared yet uncertain.'"

In a despatch dated August 18, Mr. Seward thus states the position of the United States, relative to the war between France and Mexico: "This Government, relying on the explanations which have been made by France, regards the conflict as a war involving claims by France which Mexico has failed to adjust to the satisfaction of her adversary, and it avoids intervention between the belligerents."

The quiet posture of affairs between the two Governments continued undisturbed, notwithstanding numerous rumors relative to media-

tion or intervention by France in American affairs. On the 6th of November, Mr. Dayton had a conference with M. Drouyn de l'Huys, who, on the 18th of October, succeeded M. Thouvenel, which he has thus related to Secretary Seward:

I have to-day had a conversation of some length with M. Drouyn de l'Huys in reference to our affairs. I told him that circumstances were such as to induce me to ask him distinctly whether any action was in contemplation by France, or by France conjointly with other powers, in reference to the condition of things in our country. He said no; that everything remained as it had done for some time past. That France, in common with the other powers of Europe, very much regretted the war and its continuance, but they had no purpose to intervene or interfere in any way. I then said to him I had seen it stated that France, England, and Russia were conferring upon the propriety of offering mediation. He said that the wish that the war could be ended, or that something could be done, with the assent of the belligerent parties, had been spoken of, and it was yet spoken of, but nothing had been resolved upon. In further conversation he said that France reserved to herself the right to express this wish to the parties if it should be thought advisable to do so, or that good would grow out of it. I told him that this at once brought us back to the starting point; that the expression of such wish would be, I presumed, but an offer of mediation in another form. He said no; if there were any word which could express less than "mediation," that such word should be used in its place.

To test the character of this offer or suggestion, which he reserved to himself the right to make, I said: suppose your offer or suggestion, if made, shall be refused, what will be the consequences? He said: "nothing;" that we would be friends, as we had been before. I told him that I had just seen it stated in the English press, that some such offer of mediation was to be made by the three Powers, and, in the event of our refusal to accept it, the independence of the South was to be acknowledged. He said that was not so; that no such consequences would follow a refusal upon our part; that things would remain as before. I told him that we should look upon an acknowledgment of the South as but a form of intervention. To this he assented, and said they did not think of intruding into our affairs in any way, or intervening in any form; that their intent would be comprised in the expression of a wish to be useful, if it could be done with the assent of both parties. I told him that the Emperor, at an early day, had expressed such wish, and that he had been willing to act the part of a friend between the two, if they should mutually request it. He said that such was yet his disposition, and nothing more, except that the calamities of this civil war had increased and strengthened the wish on his part.

I may add that I said to M. Drouyn de l'Huys, unofficially, however, as I told him, that such an offer, if it should even be made, would come to nothing.

The correspondence with the Government of France contained in the volume published by the order of Congress, closes on the 6th of November. Subsequently, Congress called for the continuation of the correspondence, and it was published in a separate form. It embraces the action of the respective governments on the subject mentioned in the note of November 6th above.

On the 17th of November, Mr. Dayton writes to M. Drouyn de l'Huys, stating that the occasion of his letter is found in some questions asked by M. Drouyn de l'Huys relative to the population of the Southern States, of the United States,

and to the position of the several divisions of the Federal army, and also in the following statement contained in a despatch from his Majesty's Government to its ministers at London and St. Petersburg. (*See PUBLIC DOCUMENTS.*) In that despatch M. Drouyn de l'Huys said: "There has existed between the belligerents, from the very outset of the war, an equality of strength which has been almost constantly maintained ever since; and after so much bloodshed, they are now, in this respect, very nearly in the same position as at first. Nothing justifies the expectation of any more decided military operations at an early day." In his letter, Mr. Dayton proceeds to describe the result of the army operations, and the ground lost by the Confederate States, respecting which he thus concludes:

In a word, the insurgents do not now hold a foot of ground which they did not hold early in the war, while the flag of the Union has been constantly advanced, and now floats somewhere on the soil or over the fortifications of every slave State (save one). Their armies have in the mean time been driven from an area of country embracing in the aggregate not less than one hundred thousand square miles, and occupied by a population ranging from one million and a half to two millions of people.

He then examines the census returns for the population of the antagonist portions of the Union, and considers the money and other resources, thus intending to show the degree of inequality between the combatants, for the purpose of modifying the opinion of the French minister.

On the 23d, M. Drouyn de l'Huys replied as follows:

It is none the less true that, notwithstanding the inequality of numbers and of financial means, notwithstanding local advantages and partial conquests, the conditions of soil and of climate seem to oppose insuperable obstacles to the progress of the struggle, and that the equal energy of both sides tends to impress upon it a character of indomitable desperation. I am prepared to render homage with you to the courage which the Americans upon the one side and the other have shown thus far; but this courage, even while it excites the admiration of the world, is only calculated to render more uncertain the result of the combats, and to retard the termination of the disasters of this bloody war.

You know, sir, what feelings this sad spectacle has given rise to in us; you know the step which a profound sympathy for America has inspired in the Government of the Emperor, in the hope of opening a way to a reconciliation. This step you know also ought and could take place in the opinion of the Emperor only with the consent and concurrence of the two belligerent parties. At present the reception given to our proposition by the Cabinets of London and St. Petersburg prevents us from thinking of pursuing it further; but I can assure you, sir, that our friendly dispositions have not changed. If some day the Americans, tired of turning their valor against themselves, should wish to have recourse to us in order to seek in concert the means of terminating this conflict, they would find us always ready (be it in associating ourselves with other Powers, or be it separately) to aid them with our coöperation, and to testify, by our good offices, feelings which have not ceased to animate France in regard to them.

A despatch from Mr. Seward to Mr. Dayton, dated Nov. 30th, expresses the views of the

Government on the unsuccessful proposition of France to Great Britain and Russia. He says:

An inconclusive conference concerning the United States has been held between these Powers, all of whom avow themselves as friends of the United States, and yet the United States were carefully excluded from the conference. Neither party in the conference proposed any combination to coerce the will or control the policy of the United States.

Under these circumstances the United States are not called upon to say what they would have done if the proposition of France, which was declined by Russia and Great Britain, had been adopted and carried into effect. Nor are we called upon to discuss the propriety of the positions and proceedings respectively of the several parties in the conference. Such a debate upon a subject which has already lost its practical character, or which, to speak more accurately, has not attained such a character, might produce irritations and jealousies which the President desires to avoid.

On the 15th of January, 1863, Mr. Dayton writes to Mr. Seward that a despatch will shortly be sent by M. Drouyn de l'Huys to M. Mercier, the French ambassador at Washington, requesting him to suggest to the Federal Government, the propriety of appointing commissioners to treat with the South for peace, and for union, if possible; if not possible, for such terms of separation as may be mutually agreed upon. The despatch proposed no interference of any kind by a foreign Power, nor required or asked any cessation of hostilities pending the negotiation, but like the negotiation for peace in 1783, between the United States and Great Britain, permitted everything to proceed as if no effort for a settlement were being made.

The despatch thus alluded to was addressed to M. Mercier by M. Drouyn de l'Huys on the 9th of January, and was as follows:

DEPARTMENT OF FOREIGN AFFAIRS,  
Political Division, Paris, January 9, 1863. }

SIR: If, in forming the purpose of assisting, by the proffer of our good offices, to shorten the period of those hostilities which are desolating the American continent, we had not been guided, beyond all, by the friendship which actuates the Government of the Emperor in regard to the United States, the little success of our overtures might chill the interest with which we follow the fluctuations of this contest. But the sentiment to which we have yielded is too sincere for indifference to find a place in our thoughts, and that we would cease to be painfully affected whilst the war continues to rage. We cannot regard without profound regret this war, worse than civil, comparable to the most terrible distractions of the ancient Republics, and whose disasters multiply in proportion to the resources and the valor which each of the belligerent parties develop.

The Government of his Majesty have, therefore, seriously examined the objections which have been made to us, where we have suggested the idea of a friendly mediation, and we have asked ourselves whether they are truly of a nature to set aside as premature every tentative to a reconciliation. On one part has been opposed to us the repugnance of the United States to admit the intervention of foreign influence in the dispute; on the other the hope, which the Federal Government has not abandoned, of attaining its solution by force of arms.

Assuredly, sir, recourse to the good offices of one or more neutral Powers contains nothing incompatible with the pride so legitimate amidst a great nation, and wara purely international are not those alone which

furnish examples of the useful character of mediation. We flatter ourselves, besides, that in proffering to place ourselves at the disposal of the belligerent parties to facilitate between them negotiations, the basis of which we abstain from prejudging, we have manifested to the patriotism of the United States all the considerations to which it is entitled, now perhaps still more than ever, after such a new proof of moral force and energy. We are none the less ready, amid the wishes which we form in favor of peace, to take into account all susceptibilities of national feeling, and we do not at all question the right of the Federal Government to decline the coöperation (*concours*) of the great maritime Powers of Europe.

But this coöperation, is it not the only means which offers itself to the Cabinet of Washington to hasten the close of the war? And if it believes that it ought to repel any foreign intervention, could it not honorably accept the idea of direct informal conferences (*pour parler*) with the authority which may represent the States of the South.

The Federal Government does not despair, we know, of giving a more active impulse to hostilities; its sacrifices have not exhausted its resources, still less its perseverance and its steadfastness. The protraction of the struggle, in a word, has not shaken its confidence in the definite success of its efforts. But the opening of informal conferences between the belligerent parties does not necessarily imply the immediate cessation of hostilities. Negotiations about peace are not always the consequence of a suspension of warfare; they precede, on the contrary, more often the establishment of a truce. How many times have we not seen plenipotentiaries meet, exchange communications, agree upon all the essential provisions of treaties, resolve, in fine, the question even of peace or war, whilst the leaders of armies continued the strife and endeavored even to the latest moment to modify by force of arms the conditions of peace? To recall only one memory, drawn from the history of the United States—the negotiations which consecrated their independence were commenced long before hostilities had ceased in the New World, and the armistice was not established until the act of the 30th November, 1862, which under the name of provisional articles embraced in advance the principal clauses of the definitive treaty of 1783.

Nothing, therefore, would hinder the Government of the United States, without renouncing the advantage which it believes it can attain by the continuation of the war, from entering upon informal conferences with the Confederates of the South, in case they should show themselves disposed thereto. Representatives or commissioners of the two parties could assemble at such point as it should be deemed proper to designate, and which could, for this purpose, be declared neutral. Reciprocal complaints would be examined into at this meeting. In place of the accusations which North and South mutually cast upon each other at this time, would be substituted an argumentative discussion of the interests which divide them. They would seek out by means of well ordered and profound deliberations whether these interests are definitively irreconcilable—whether separation is an extreme which can no longer be avoided, or whether the memories of a common existence, whether the ties of any kind which have made of the North and of the South one sole and whole Federative State, and have borne them on to so high a degree of prosperity, are not more powerful than the causes which have placed arms in the hands of the two populations. A negotiation, the object of which would be thus determinate, would not involve any of the objections raised against the diplomatic intervention of Europe, and, without giving birth to the same hopes as the immediate conclusion of an armistice, would exercise a happy influence on the march of events.

Why, therefore, should not a combination which respects all the relations of the United States obtain the approbation of the Federal Government? Persuaded on our part that it is in conformity with their true

interests, we do not hesitate to recommend it to their attention; and, not having sought in the project of a mediation of the maritime Powers of Europe any vain display of influence, we would applaud, with entire freedom from all susceptibility of self-esteem, the opening of a negotiation which would invite the two populations to discuss, without the coöperation of Europe, the solution of their difference.

I request you, sir, to give this assurance to the Cabinet of Washington, while commending to its wisdom counsels dictated by most sincere interest in the prosperity of the United States. You are moreover authorized, if Mr. Seward expresses the wish, to leave with him a copy of this despatch.

Accept, sir, the assurance of my high consideration.  
DROUYN DE L'HUYS.

To M. MERCIER, Minister of France at Washington.

On the 6th of February, 1863, Mr. Seward addressed a despatch to Mr. Dayton in reply to his note stating that mediation between the combatants was about to be proposed, and expressing the views under which such a proposition would be received by the Government of the United States. This important despatch was as follows:

DEPARTMENT OF STATE, WASHINGTON, Feb. 6, 1863.

Sir: The intimation given in your despatch of January 15th (No. 255), that I might expect a special visit from M. Mercier has been realized. He called on the 3d instant, and gave me a copy of a despatch which he had just then received from M. Drouyn de l'Huys under the date of the 9th of January.

I have taken the President's instructions, and I now proceed to give you his views upon the subject in question.

It has been considered with seriousness, resulting from the reflection that the people of France are known to be faultless sharers with the American nation in the misfortunes and calamities of our unhappy civil war; nor do we on this, any more than on other occasions, forget the traditional friendship of the two countries, which we unhesitatingly believe has inspired the counsels that M. Drouyn de l'Huys has imparted.

He says, "the Federal Government does not despair, we know, of giving more active impulse to hostilities;" and again he remarks, "the protraction of the struggle, in a word, has not shaken the confidence (of the Federal Government) in the definite success of its efforts."

These passages seem to me to do unintentional injustice to the language, whether confidential or public, in which this Government has constantly spoken on the subject of the war. It certainly has had and avowed only one purpose—a determination to preserve the integrity of the country. So far from admitting any laxity of effort, or betraying any despondency, the Government has, on the contrary, borne itself cheerfully in all vicissitudes, with unwavering confidence in an early and complete triumph of the national cause. Now, when we are, in a manner, invited by a friendly power to review the twenty-one months' history of the conflict, we find no occasion to abate that confidence. Through such an alternation of victories and defeats as is the appointed incident of every war, the land and naval forces of the United States have steadily advanced, reclaiming from the insurgents the ports, forts, and posts which they had treacherously seized before the strife actually began, and even before it was seriously apprehended. So many of the States and districts which the insurgents included in the field of their projected exclusive slaveholding dominions have already been reestablished under the flag of the Union, that they now retain only the States of Georgia, Alabama, and Texas, with half of Virginia, half of North Carolina, and two thirds of South Carolina, half of Mississippi, and one third respectively of Arkansas and

Louisiana. The national forces hold even this small territory in close blockade and siege.

This Government, if required, does not hesitate to submit its achievements to the test of comparison; and it maintains that in no part of the world, and in no times, ancient or modern, has a nation, when rendered all unready for combat by the enjoyment of eighty years of almost unbroken peace, so quickly awakened at the alarm of sedition, put forth energies so vigorous, and achieved successes so signal and effective as those which have marked the progress of this contest on the part of the Union.

M. Drouyn de l'Huys, I fear, has taken other light than the correspondence of this Government for his guidance in ascertaining its temper and firmness. He has probably read of divisions of sentiment among those who hold themselves forth as organs of public opinion here, and has given to them an undue importance. It is to be remembered that this is a nation of thirty millions, civilly divided into forty-one States and Territories, which cover an expanse hardly less than Europe; that the people are a pure democracy, exercising everywhere the utmost freedom of speech and suffrage; that a great crisis necessarily produces vehement as well as profound debate, with sharp collisions of individual, local, and sectional interests, sentiments, and ambitions; and that this heat of controversy is increased by the intervention of speculations, interests, prejudices, and passions from every other part of the civilized world. It is, however, through such debates that the agreement of the nation upon any subject is habitually attained, its resolutions formed, and its policy established. While there has been much difference of popular opinion and favor concerning the agents who shall carry on the war, the principles on which it shall be waged, and the means with which it shall be prosecuted, M. Drouyn de l'Huys has only to refer to the statute book of Congress and the Executive ordinances to learn that the national activity has hitherto been and yet is, as efficient as that of any other nation, whatever its form of government, ever was, under circumstances of equally grave import to its peace, safety, and welfare. Not one voice has been raised anywhere, out of the immediate field of the insurrection, in favor of foreign intervention, of mediation, of arbitration, or of compromise, with the relinquishment of one acre of the national domain, or the surrender of even one constitutional franchise. At the same time, it is manifest to the world that our resources are yet abundant, and our credit adequate to the existing emergency.

What M. Drouyn de l'Huys suggests is that this Government shall appoint commissioners to meet, on neutral ground, commissioners of the insurgents. He supposes that in the conferences to be thus held, reciprocal complaints could be discussed, and in place of the accusations which the North and South now mutually cast upon each other, the conferees would be engaged with discussions of the interests which divide them. He assumes, further, that the commissioners would seek, by means of well-ordered and profound deliberation, whether these interests are definitively irreconcilable, whether separation is an extreme that can no longer be avoided, or whether the memories of a common existence, the ties of every kind which have made the North and the South one whole Federative State, and have borne them on to so high a degree of prosperity, are not more powerful than the causes which have placed arms in the hands of the two populations.

The suggestion is not an extraordinary one, and it may well have been thought by the Emperor of the French, in the earnestness of his benevolent desire for the restoration of peace, a feasible one. But when M. Drouyn de l'Huys shall come to review it in the light in which it must necessarily be examined in this country, I think he can hardly fail to perceive that it amounts to nothing less than a proposition that, while this Government is engaged in suppressing an armed insurrection, with the purpose of maintaining the constitutional national authority, and preserving the integrity of the

country, it shall enter into diplomatic discussion with the insurgents upon the questions whether that authority shall not be renounced, and whether the country shall not be delivered over to disunion, to be quickly followed by ever increasing anarchy.

If it were possible for the Government of the United States to compromise the national authority so far as to enter into such debates, it is not easy to perceive what good results could be obtained by them.

The commissioners must agree in recommending either that the Union shall stand or that it shall be voluntarily dissolved; or else they must leave the vital question unsettled, to abide at last the fortunes of the war. The Government has not shut out knowledge of the present temper, any more than of the past purposes of the insurgents. There is not the least ground to suppose that the controlling actors would be persuaded at this moment, by any arguments which national commissioners could offer, to forego the ambition that has impelled them to the disloyal position they are occupying. Any commissioners who should be appointed by these actors, or through their dictation or influence, must enter the conference imbued with the spirit and pledged to the personal fortunes of the insurgent chiefs. The loyal people in the insurrectionary States would be unheard, and any offer of peace by this Government, on the condition of the maintenance of the Union, must necessarily be rejected.

On the other hand, as I have already intimated, this Government has not the least thought of relinquishing the trust which has been confided to it by the nation under the most solemn of all political sanctions; and if it had any such thought, it would still have abundant reason to know that peace proposed at the cost of dissolution would be immediately, unreservedly, and indignantly rejected by the American people. It is a great mistake that European statesmen make, if they suppose this people are demoralized. Whatever, in the case of an insurrection, the people of France, or of Great Britain, or of Switzerland, or of the Netherlands would do to save their national existence, no matter how the strife might be regarded by or might affect foreign nations, just so much, and certainly no less, the people of the United States will do, if necessary to save for the common benefit the region which is bounded by the Pacific and the Atlantic coasts, and by the shores of the Gulfs of St. Lawrence and Mexico, together with the free and common navigation of the Rio Grande, Missouri, Arkansas, Mississippi, Ohio, St. Lawrence, Hudson, Delaware, Potomac, and other natural highways by which this land, which to them is at once a land of inheritance and a land of promise, is opened and watered. Even if the agents of the American people now exercising their power should, through fear or faction, fall below this height of the national virtue, they would be speedily, yet constitutionally, replaced by others of sterner character and patriotism.

I must be allowed to say, also, that M. Drouyn de l'Huys errs in his description of the parties to the present conflict. We have here, in the political sense, no North and South, no Northern and Southern States. We have an insurrectionary party, which is located chiefly upon and adjacent to the shore of the Gulf of Mexico; and we have, on the other hand, a loyal people, who constitute not only Northern States, but also Eastern, Middle, Western, and Southern States.

I have on many occasions heretofore submitted to the French Government the President's views of the interests, and the ideas more effective for the time than even interests, which lie at the bottom of the determination of the American Government and people to maintain the Federal Union. The President has done the same thing in his Messages and other public declarations. I refrain, therefore, from reviewing that argument in connection with the existing question.

M. Drouyn de l'Huys draws to his aid the conferences which took place between the Colonies and Great Britain in our Revolutionary War. He will allow us to assume that action in the crisis of a nation

must accord with its necessities, and therefore can seldom be conformed to precedents. Great Britain, when entering on the negotiations, had manifestly come to entertain doubts of her ultimate success; and it is certain that the councils of the Colonies could not fail to take new courage, if not to gain other advantage when the parent State compromised so far as to treat of peace on the terms of conceding their independence.

It is true, indeed, that peace must come at some time, and that conferences must attend, if they are not allowed to precede the pacification. There is, however, a better form for such conferences than the one which M. Drouyn de l'Huys suggests. The latter would be palpably in derogation of the Constitution of the United States, and would carry no weight, because destitute of the sanction necessary to bind either the disloyal or the loyal portions of the people. On the other hand, the Congress of the United States furnishes a constitutional forum for debates between the alienated parties. Senators and representatives from the loyal portion of the people are there already, freely empowered to confer; and seats also are vacant, and inviting senators and representatives of this discontented party who may be constitutionally sent there from the States involved in the insurrection. Moreover, the conferences which can thus be held in Congress have this great advantage over any that could be organized upon the plan of M. Drouyn de l'Huys, namely—that the Congress, if it were thought wise, could call a national convention to adopt its recommendations, and give them all the solemnity and binding force of organic law. Such conferences between the alienated parties may be said to have already begun. Maryland, Virginia, Kentucky, Tennessee, and Missouri—States which are claimed by the insurgents—are already represented in Congress, and submitting with perfect freedom and in a proper spirit their advice upon the course best calculated to bring about, in the shortest time, a firm, lasting, and honorable peace. Representatives have been sent also from Louisiana, and others are understood to be coming from Arkansas.

There is a preponderating argument in favor of the Congressional form of conference over that which is suggested by M. Drouyn de l'Huys, namely, that while an accession to the latter would bring this Government into a concurrence with the insurgents in disregarding and setting aside an important part of the Constitution of the United States, and so would be of pernicious example, the Congressional conference, on the contrary, preserves and gives new strength to that sacred writing which must continue through future ages the sheet anchor of the Republic.

You will be at liberty to read this despatch to M. Drouyn de l'Huys, and to give him a copy if he shall desire it.

To the end that you may be informed of the whole case, I transmit a copy of M. Drouyn de l'Huys's despatch.

I am, sir, your obedient servant,  
WILLIAM H. SEWARD.

The correspondence with France during the year 1862 presents only a single instance of a complaint on the part of the United States Government. It is the case of an American citizen injured by some French soldiers at Vera Cruz. Throughout these pages her friendship appears steadfast and sincere. Not an instance of a departure from strict neutrality is found. No armed vessel left her ports, nor contraband articles were shipped by her citizens. Her minister expressly declares that if any suggestions looking to a peaceful close of this bloody American conflict should be made by his government, and refused by the American, nothing would follow. Mr. Dayton writes that he said to him, on October 13: "Suppose your offer,

or suggestion, if made, shall be refused, what will be the consequences?" He replied: "Nothing; we would be friends as we had been before."

*Russia.*—The correspondence with Russia is unimportant, except so far as it indicates the friendly spirit of that government towards this country. In absence of Mr. Simon Cameron, who succeeded Mr. C. M. Clay, the secretary of legation, Mr. Bayard Taylor, reports a conference with Prince Gortchakoff on October 29. "Your situation," said he, "is getting worse and worse. The chances of preserving the Union are growing more and more desperate. Can nothing be done to stop this dreadful war? Can you find no basis of arrangement before your strength is so exhausted that you must lose for many years to come your position in the world?"

*Spain.*—Only one or two points of interest appear in the correspondence with the government of Spain, conducted, in the absence of General Schurz, through the secretary of legation, Mr. Horatio J. Perry. On the 22d of April, Mr. Seward writes to Mr. Perry: "I think that you may be able to satisfy that eminent minister, Mr. Calderon Collantes, that the largest term which can readily be claimed for this civil war is a period of two years from its date."

Subsequently, General Schurz resigned the mission to Spain, and was succeeded by Mr. Gustavus Koerner, of Illinois.

A protest was made by the government of the United States upon the annexation of Dominica to Spain.

On the 11th of July, in a conversation with Mr. Perry, the Spanish minister for Foreign Affairs, Mr. Collantes, alluded to the treaty recently negotiated with Great Britain for the suppression of the slave trade. The conference is thus stated by Mr. Perry:

At a recent interview with Mr. Calderon Collantes, that minister inquired if I had received a copy of the treaty recently concluded between the United States and England, concerning the mutual right of search, for the suppression of the African slave trade. He was much surprised that, after combating that principle so long, the United States should have yielded now a right so exceedingly liable to be abused in practice, and he was very curious to know what provisions had been stipulated to guard the exercise of the right from such abuse.

I replied, regretting I could give no information other than what Mr. Calderon had himself seen in the newspapers. I understood, however, that the stoppage of the use of the American flag in the slave trade was an object which would naturally commend itself to the favor of the present government of the United States, and I inquired if Spain had not herself conceded the same right.

Mr. Calderon said that she had, at a period of her history which could not be recalled with pleasure, but that ever since he himself had held the portfolio of foreign affairs he had been desirous of an opportunity to revise that whole treaty in which the right of search was thus granted to Great Britain. The exercise of this right was vexatious, and, besides, the English were always talking in Parliament and out, of their having purchased this right of Spain for £40,000 sterling money, always putting their money forward, and

he (Mr. Calderon) would be exceedingly glad of an opportunity to give them their £40,000 and have the treaty back again.

Mr. Calderon asked me if I supposed the recent treaty would be ratified by the American Senate. I replied I had no reasonable doubt that it would be, and remarked that I supposed that England was now taking steps to obtain the same concession from the government of France.

Mr. Calderon said he had little doubt of it, but he wished to see the American treaty, as it might afford a basis for demanding a revision of the Spanish treaty as to the manner in which this right was to be exercised.

The remainder of this voluminous correspondence is occupied with subjects of less in-

terest. The volume is a proof of the vast labors of the Department of State, which has been conducted during the year with great ability and success, in preserving the peaceful and most friendly relations with foreign nations.

DRURY BLUFF is situated seven miles below Richmond on the James river. It is in a commanding position, owing to the curve of the river, and was strongly fortified to prevent the approach of the Federal gunboats to Richmond. An attack was made upon it by the iron clad Galena and several gunboats, which were severely handled and retired. (*See NAVAL OPERATIONS.*)

## E

**EARTH.** Among the scientific deductions and speculations respecting our planet, put forth during the year, are some which would seem likely to lead to very considerable modifications of the views for some time entertained in regard to its constitution and behavior as a physical globe, and more especially in regard to the condition of its interior mass.

*Relative Sunshine of Different Zones.* Prof. Hennessy, speaking before the British association on this subject, called attention to the fact that by means of transformation of a mathematical formula of Poisson, the area of that portion of the earth's equatorial regions which receives as great an amount of sunshine as all the rest of the surface, is readily ascertained. This area is found to be that which is bounded, at the outer limits of the earth's atmosphere, by parallels distant  $23^{\circ} 44' 40''$  on each side of the equator. Since such parallels lie very slightly without the tropics, it follows that the amount of sunshine falling on the outer limit of the atmosphere, between the tropics, is very nearly equal to that falling upon the atmosphere corresponding to the entire remaining portion of the earth. Now, the researches of Prof. Forbes have shown that the portion of the sun's heat extinguished by the atmosphere during passage through it of a given solar ray, and before it reaches the surface of the globe itself, exceeds one half for all inclinations of the ray to the surface less than  $25^{\circ}$ ; and that for inclinations of  $5^{\circ}$ , only about  $\frac{1}{20}$ th part of the heat reaches the ground. The torrid zone, accordingly, must receive the action of by far the greater part of the sun's heat; and it will follow that the distribution of the absorbing and radiating surfaces within such zone must exercise an influence the extent of which is not usually suspected, in modifying the climates of all parts of the earth's surface.

*Extent of the Earth's Atmosphere.* Prof. Challis, before the same body, argued that the earth's atmosphere could not extend so far as to the moon, since, in case it did so, some portions of it must attach themselves by gravita-

tion to that satellite, and these having connection through friction with the rest, there would result a continual drag upon the earth's surface, retarding its rotation. If, then, the earth's rotation be uniform, its atmosphere cannot extend so far as in any degree to be drawn to the moon. Undoubtedly, as generally supposed, the atmosphere terminates at some height not very great, and abruptly; that is, with a definite boundary or surface, at which it has a small but finite density, and beyond which there are no more atmospheric particles. From considerations drawn from the rate of decrease of density in ascending from and near to the earth's surface, this height is usually placed at about 70 miles.

*Thickness of the Earth's Crust.* Led chiefly by the phenomena of thermal springs, of earthquakes and volcanoes, together with the observed rise of temperature in descending in mines and the boring of artesian wells, and connecting with these the appearances of the lower or unstratified rocks, and the interpretation given to all the facts by Laplace's nebular hypothesis, geologists have for many years past become pretty generally agreed in regarding our globe as still possessing but a thin solid crust enveloping an intensely hot and molten core; and from calculations of the depths at which the metals and finally the most refractory rock materials must melt, the thickness of such crust has been supposed no greater than 100, 70, and by some even 30 miles. Within a very few years, however, objections to this theory, or at the least to that of such extreme thinness of solid earth, have sprung up in different and unexpected quarters. About three years since, the Rev. J. H. Pratt, residing at Calcutta, and to whom the immense quantity of matter piled up in the long and massive Himalayan chains had become a very patent fact, published his views to the effect that, through differing pressures at near parts of the crust, where the weight of chains like the Himalayas is far under-balanced by the diminished pressure on ocean bottoms, while the



tendency of lava tides within the earth at times of conjunction of the sun and moon must conspire with such differences, the crust of the earth must at such places and times suffer rupture, unless at least 140, and more probably from 300 to 500 miles thick. To this, the Rev. Mr. Haughton replied that Mr. Pratt overlooks the principle of the arch, which serves to increase practically the strength of the strata, and also the very high crushing strength of granite—not less than 24,000 lbs. to the cubic inch.

Prof. William Thomson presented before the Royal Society, May 15, 1862, a paper on the "Rigidity of the earth," considered in its bearings on this question. Premising that he would communicate also, on an early occasion, a mathematical theory of the deformation of elastic spheroids, and which would illustrate his conclusions in respect to the effect of the tide-generating influence of the sun and moon on the mass of the earth, he proceeded to show that unless the solid portions of the earth be on the whole of extremely rigid material—more rigid than steel—it must yield to the attractions of those bodies, in the way of a tide of the solid strata, and to such an extent as very sensibly to diminish the actual oceanic tides, as well as the well known changes in direction of the earth's axis denoted under the terms precession and nutation. A homogeneous and incompressible elastic spheroid, of the same mass and volume with the earth, if it have the rigidity of glass, would yield to the luni-solar tide action to about  $\frac{1}{3}$ , and if it have the rigidity of steel, to about  $\frac{1}{5}$ , of the extent to which a perfectly fluid globe of equal density must yield. In the former case, the actual amounts of the water tides, and of the precession and nutation, would be only  $\frac{1}{3}$ , in the latter  $\frac{1}{5}$ , of the amounts that would hold true in case of a perfectly rigid spheroid of the like dimensions, figure, and supposed uniform density. But the theory of precession and nutation has always hitherto proceeded upon the supposition that the earth, in respect to its exterior form, is practically a completely rigid body; and the calculations deduced from such theory have closely agreed with observation. It is scarcely possible to admit that there can have been between the theory and facts any such discrepancy as required by the ratio of 3 to 5; and the conclusion then almost necessarily follows, that the earth, as a whole, is much more rigid than steel. The author suggests, as a further test, careful observations on the lunar fortnightly and the solar half-yearly tides, made say at Iceland and Teneriffe, since the agency of either the sun or moon in producing tides at and near the poles is greatest when such body has the greatest declination N. or S. of the equator; and by means of two such stations, the actual diminution of the ocean tide by an earth tide, if there be any, would more likely be ascertained. From data already at command Prof. Thomson regards it as certain that the

general globe is far more rigid than glass, probably more so than steel. But in order to such result, the interior must be even more rigid than the superficial parts; and this is just what would be expected, if the interior being solid, the enormous pressure upon it be taken into account. The actual rigidity, however, appears utterly inconsistent with the hypothesis of many geologists, of the earth as mainly a molten mass, inclosed in a shell 80 to 100 miles thick. These investigations confirm those of Mr. Hopkins, who is led to conclude that the solid crust cannot be at the least less than 800 miles in thickness; and in view of the apparent absence of any interference with ocean tides and precession, the author believes it impossible the solid portion of the earth should have a depth less than 2,000 to 2,500 miles.

*Eccentricity of the Earth.* Mr. W. Ogilby (Brit. Assoc.), uses the term *eccentricity* to denote that quality in virtue of which the earth's centre of gravity, as he believes he has proved to be the case, is situated to one side of the axis about which its rotation takes place. He sets out with the principles that, in a freely revolving body like the earth, the axis of figure must, under all circumstances, coincide with the axis of rotation, and the centre of figure with the centre of the generating sphere. This centre is a mathematical point, fixed and immovable, whatever changes of revolution the body may undergo. But the centre of gravity is a physical point, its position dependent on the constitution of the body, and changing with alterations in the density or arrangement of its materials. Since the earth is neither a homogeneous body, nor composed of spherical shells severally homogeneous, its centre of gravity needs not coincide with its centre of figure; and facts lead to the conclusion that it does not, and further, that it does not remain a fixed point. These consequences follow from the irregular density of the globe, and again from the transportation always going on, of millions of tons of solid materials from one part of the earth to another, to say nothing of tides, rivers, ocean currents, or of possible effects of electrical currents within the earth. Reasoning from the known forms, places, and dimensions of the continents, and in like manner of the oceans, with the average depths of the latter, with other circumstances, Mr. Ogilby deduces the place of the earth's centre of gravity as full one statute mile toward the Asiatic side from its centre of figure.

If, as probable, the axis of rotation originally passed through the centre of gravity—i. e., if it was a principal axis—this, provided that the centre of gravity had remained fixed, would have been indefinitely maintained. But with the revolution itself the transport of materials would probably commence; and the alteration of the globe accumulating during a given geological epoch, the gravitative centre would in the lapse of ages come to diverge materially

from that of figure. Either, now, the axis keeping its place will be no longer a principal axis, or following the receding centre of gravity, the figure of the globe must change correspondingly, to allow of rotation about the new direction. The rigid materials of the earth forbid any gradual accommodation of the form; and the axis of rotation remains fixed; but the constraint thus imposed by the earth's rigidity on the axis occasions a pressure tending continually to restore the axis to the position in which it will be a principal axis, so that the materials of the globe may revolve with balanced forces about it. This tendency accumulating, must in the course of ages exceed the force of rigidity, which is a constant quantity, and the axis breaking away suddenly must be restored to the direction through the centre of gravity, becoming anew a principal axis. The accomplishing of such change must be attended with those fearful convulsions, dislocation of strata or bodies of land, and cataclysms, which mark the boundaries of geological epochs: and which, at remote periods, change the face of the continents, alter the distribution of heat and cold, upheave mountain chains, and overwhelm whole tribes of organized beings in a common and general destruction. The author supposes that minuter displacements of the axis may go on, or suddenly occur, at other than these great epochs of change; and that earthquakes are perhaps the disturbances due to convulsive efforts of the revolving globe to throw its actual axis, which is not one of equilibrium, into the place of a principal axis, which would be such. It must be said at this point, that a careful consideration of the actual phenomena attending earthquakes, and of their connection with volcanic eruptions, will suggest many difficulties in regard to this part of the theory. Mr. Ogilby declares, however, that a comparison of the observations of Eratosthenes with those of the present time, after all due allowance for variation of obliquity of the earth's axis to that of the ecliptic and for errors of observation is made, proves that the latitude of Syene has increased within the last 2,100 years to the amount of  $17^{\circ} 21' .5$ ; and he intimates that the astronomer royal has recently detected a slight annual motion of the pole very nearly corresponding in amount to this.

Mr. Robert Mallet, O. E., whose researches during a few years past into the phenomena of earthquakes have well nigh established the claims of *Seismology* to be regarded as a science, laid before the Royal Society, May 8, 1862, a sequel to his "Reports on Earthquake-Wave Experiments," and in which he gave the results for certain species of rocks, of investigations into the Velocity of Earthquake Waves. He first determined the ratio (*modulus*) of elasticity, separately, of slate and quartz rocks, hard and soft, and in directions both parallel and transverse to the direction in which the laminae (or the strata) of those rocks are placed: this, of course, involving 8 separate series of

experiments, and in which the observations were made at intervals of pressure increasing continually by 1,000 lbs. He finds that generally quartz rock is less compressible than slate; while, on the contrary, the softest quartz is much more compressible than the softest slate, when the pressure occurs in both in the direction parallel to their laminae. In the like direction, the hardest slate is more than twice as compressible as the hardest quartz. In the direction transverse to the laminae, slate and quartz, whether soft or hard, have in each condition very nearly the same compressibility; but in this direction, the compressions of the softest are about 4 times those of the hardest of these rocks. The great compressibility parallel to the laminae appears to arise chiefly from the fact that the mass of the rock is made up of minute wedge-shaped mineral particles, deposited with their largest dimensions lying mainly in the direction of the plane of the laminae, and so acting upon each other like so many wedges. The wave transmitted transversely to the laminae will, if the rocks are equally solid and continuous both ways, be the greater; but breaks and discontinuity of any sort must retard its advance. Mr. Mallet deduces mathematically the conclusions that, were the rocks perfectly solid and continuous, the mean velocity of wave transmission for slate and quartz would be—transverse to the laminae, 18,715 ft. per second; and parallel with the laminae, 7,659 ft. per second. In nature, however, owing to the greater discontinuity of the rocks in the former direction, the relative velocities of waves in the two directions must be nearly the reverse of these. The results, though apparently disagreeing with those of Helmholtz and others in reference to compressibility and elasticity of wood in the three principal directions of section (see Wood, New Amer. Cyclopædia), do not so disagree in reality. In case of an earthquake in Italy, Dec. 16, 1857, the phenomena of which Mallet has thoroughly investigated, and the primitive shock of which was delivered in an upward line (the *seismic* vertical), piercing the village of Caggiano, in the valley of Salamis, the actual velocity of the wave not far from this point was found to be 700–800 ft. per second; the velocity of any single wave-particle being 13–14 ft. per second. These velocities diminish with increasing distance from the central point of impulsion, until they disappear in parts where the wave ceases to be propagated.

EDUCATION. The diffusion of education in the United States has been greater than in any other country of the world, excepting perhaps the kingdom of Prussia; but the expenditure for educational purposes is at the present time greater than in any other country. The instruction imparted has been chiefly elementary in its character, the larger part of the population being taught to read and write, and acquiring a knowledge of the elements of arithmetic, geography, history, and language. Yet

secondary and higher instruction has not been neglected, and the facilities for it are rapidly increasing. Some statistics of the present extent and magnitude of the educational interest will exhibit more forcibly than can otherwise be done, what has already been accomplished for education in the United States.

*1st, Primary Education.*—An estimate of the facilities for common school education in the United States at the close of 1861, carefully prepared by Anson Smyth, late superintendent of schools in Ohio, gives the number of children in attendance upon those schools at that date as 5,211,000, or one in  $5\frac{1}{2}$  of the free white population. Of these 4,560,000 were in what are now designated loyal States, with a population of about 18,000,000 whites, or one in four of the population; while in the other States, as a consequence of the extent of the plantations, the scattered and sparse settlements, &c., the number of children attending public schools was only 651,000 in a white population of about nine millions, or nearly one in 14 of the inhabitants. The expenditure for the support of public schools the same year was \$23,461,000, or about 87 cents for each white inhabitant. This too was divided very unequally between the two portions, \$20,385,000, or \$1.13 to each free inhabitant of the former States, and \$3,076,000, or 34 cents for each white inhabitant of the latter States. The amount of school funds belonging to the several States is not less than \$50,000,000, of which the newer States hold the larger part, and when their school lands are sold, they will have many millions of dollars more. The largest expenditure for school purposes relatively to the population is in Illinois and Massachusetts, in the former State amounting to about \$1.53 per head for the entire population, and in the latter to \$1.34 per head. In Massachusetts, however, \$1.21 per head is raised by taxation, while in Illinois only 76 cts. per head is raised in that way. In most of the Northern States the annual expenditure averages nearly \$1 per head for the inhabitants. The wages of teachers average in the Northern States \$30 per month for male teachers, and \$17.25 for female teachers, inclusive of board in both cases. In the Northern States, schools are taught an average period of 6.5 months in the year. In most of the Southern States the average wages of teachers cannot be ascertained.

*Secondary Instruction.*—The number of private schools, high schools, academies, and boarding schools, in which a more advanced course of instruction is given (in some instances in connection with the elementary studies) is not to be ascertained exactly, some of the school reports giving no account of them, and the census returns of 1860, on this point, being as yet inaccessible; but from the most careful estimates, and comparisons of States where they are enumerated they cannot be less than 20,000, and are attended by more than 600,000 children. These

schools were numerous in the Southern States before the war, and supplemented to some extent the lack of common schools; about 1,200 of them were boarding schools. The expenditure for board and tuition in these 20,000 schools has not been less than \$20,000,000 per annum, and probably exceeds that sum, the boarding schools alone receiving over \$10,000,000. The number of colleges (aside from agricultural and polytechnic colleges, which belong rather to the rank of professional schools) is about 240, and the number of undergraduates in attendance in any one year is somewhat more than 20,000. The average annual expenditure for board, tuition, room rent, and incidentals, deducted from the comparison of these expenses in about 100 colleges in different States, is \$161 per annum, the entire expenditure for collegiate education would therefore be about \$3,220,000, though the annual expenditure of these colleges, many of which are largely endowed, is not less than \$5,000,000. The college in this country, considered as an institution for undergraduate instruction, is analogous to the gymnasium in Germany, and the lyceum in France.

*Higher Education.*—The term university, used in so many senses in Europe, is hardly applicable to any of the educational institutions in this country. There are no universities like those of Oxford and Cambridge composed of numerous independent colleges, yet under a common government, and having a corps of university professors without connection with any one of the colleges more than another; nor like the University of London, an examining board, giving no instruction, but holding examinations and conferring degrees on members of thirty or forty colleges, scattered through the country; nor is there anything analogous to the German universities, which have no undergraduate course, but only impart instruction in theology, medicine, law, or philosophy; nor yet to the University of France, the great central controlling power over all education in the country, from the highest range of scientific study to the lowest primary or commercial school of the empire.

The term university is often grossly misapplied in this country; an institution never intended to bestow anything beyond the ordinary classical and mathematical instruction of the undergraduate course in the colleges, and which, in fact, has only an academical or sub-collegiate course, assumes very often the high title of university, while, in some cases, institutions like Yale College, which have, in addition to their college faculty, corps of instructors in theology, medicine, law, and physical science, are known only by the humbler title of college.

Of institutions possessing four faculties of higher instruction, there are but two in this country, viz., Harvard University and Yale College. Of those having three there are five, viz., Dartmouth College, the University of the City of New York, the University of Pennsyl-

vania, the University of Virginia, and the University of Michigan; the last named may indeed be said to have four, as although only the professions of law and medicine are taught, it has a department of fine arts, as well as one of physical and mathematical science. None of the five have faculties of theology. Of the number having two faculties of higher instruction, there are eleven or twelve; some of them have faculties of theology and medicine, others of theology and law, others still of law and medicine, and one or two of theology, law, or medicine, and the physical and mathematical sciences.

The number having a single faculty of higher instruction, usually theology or medicine, is 35. In four instances, under university charters, faculties of law or medicine (in two cases both) have been organized without any undergraduate course. These are the University of Albany, the University of Louisville, the University of St. Louis, and the University of the Pacific at San Francisco.

In by far the larger number of cases, however, the professional schools are independent, or at most have a merely nominal connection with the colleges or universities under whose charter their degrees are conferred. There are, according to the latest returns, 92 theological seminaries in the United States, having 4,120 students. As tuition is generally free in these seminaries, the annual expenditure for board, room rent, and incidentals will average about \$125 per head, or \$515,000 for the whole, while the added expenditure from endowments for the salaries of professors, &c., will increase the aggregate yearly expenditure to more than \$1,000,000.

The number of medical schools is 55, having about 7,000 students, whose average annual expenditure for lecture, hospital, and dissection tickets, and board is never less than \$200, and the aggregate yearly outlay \$1,400,000.

The number of law schools is 13, and the number of students 1,800; the annual expenditure of each is about \$200, or \$260,000 in the aggregate. The number of normal schools is 16, and of normal students 2,740. Their average annual expenditure is about \$120 or \$340,800; but, as a portion of the salaries and expenses are defrayed by the States, the entire annual cost of maintenance cannot fall below \$500,000.

The number of scientific schools, polytechnic colleges and institutes, and agricultural colleges in operation is 15, with an aggregate attendance of about 1,500 students. The annual expense per capita is not below \$200, or \$300,000, and the income of the endowments expended will increase the amount to about \$400,000.

In addition to these there are 53 institutions for the instruction and training of the deaf and dumb, blind, and idiots, having in all about 7,850 pupils, the average annual cost for whose education is \$150, or \$1,177,500.

A near approximation to the amount annually expended for education in the United

States, therefore, presents the following results:

Primary instruction, in public schools.....	\$23,461,000
Primary and secondary instruction, in private schools, academies, high schools, seminaries, and boarding schools.....	20,000,000
Secondary instruction: Colleges.....	5,000,000
Higher education: Theological schools.....	1,000,000
“ “ Medical schools.....	1,400,000
“ “ Law schools.....	260,000
“ “ Normal schools.....	500,000
“ “ Scientific schools, &c.....	400,000
Special instruction: Blind, deaf mutes, idiots, &c.....	1,177,500
Total annual expenditure for education.....	\$53,198,500
To this may be added Government expenditure for the support of the Military Academy at West Point and the Naval Academy, about.....	400,000

Total expenditure for education annually..... \$53,598,500

There has been, within a few years past, a commendable advance in the quality and extent of the instruction imparted in the colleges and schools of the country. In most of the colleges of the Eastern and Middle States, and in some of those of the Southern and Western, the instruction in the mathematical and physical sciences will compare favorably with that of the best European colleges and gymnasia. In a few cases the classical instruction is very thorough, but generally the colleges do not impart as complete and satisfactory a knowledge of the Latin and Greek languages as the European schools. Latin is seldom spoken, and not often written, except for salutatory orations or the like. In the academies and public schools there has been a marked advance in the thoroughness and carefulness of the teaching. In the elementary studies excellent manuals have been prepared, and no nation of the world has, probably, better text books for common school education than are found in the United States. The multiplication of normal schools, teachers' associations, teachers' institutes, and educational journals, have also contributed powerfully to the improvement of the schools and the elevation of the profession of teaching.

During the past year there has been a remarkable interest awakened among teachers and friends of education by the effort to introduce into the primary schools a system of instruction known as "object teaching," or "teaching by object lessons." The excitement and enthusiasm in regard to it has equalled, and perhaps exceeded, that by which Joseph Lancaster's monitorial system was received. Now, as then, educated men, occupying high positions in society, urge the general adoption of this new method, "as the best and most efficient system of teaching in primary schools."\* There is not now, more than in former times,

\* In 1810, De Witt Clinton, in a speech on opening the enlarged free school in New York, said: "I confess that I recognize in Lancaster the benefactor of the human race. I consider his system as creating a new era in education, as a blessing sent down from heaven to redeem the poor and distressed of this world from the power and dominion of ignorance." Again in his message in 1818, Gov. Clinton says: "I can confidently recommend it as an invaluable improvement, which, by wonderful combination in reduction of expense and rapidity of instruction, has created a new era in education." President Nott, in 1811, endorsed in terms almost as strong the new method, and John Adams gave it his hearty approval.

a royal road to learning, and the extravagant encomiums which have been passed upon the method of teaching by object lessons, may possibly, fifty years hence, excite as much amusement among the promoters of education of that time as Governor Clinton's eulogy on honest Joseph Lancaster's system does in our minds at the present day. Still, a notice is due to a system which so many eminent teachers unite in approving.

"Object teaching," though a novelty in its introduction into the primary schools, is by no means a new thing in the history of education. Something of the kind may be traced in Egyptian and Spartan education. In times comparatively modern, however, the system found a nearly complete development in the methods of two eminent teachers and writers on education of the seventeenth century—Wolfgang Ratich (1571-1685) and John Amos Comenius (1592-1671)—and both were indebted, partially at least, to Lord Bacon's "Instauratio Magna" for the first conception of the system. Ratich required the reading over of the lesson to the child by the teacher many times, accompanied each time by explanations and illustrations, in order to fix the phrases and the ideas together in his memory. In practice this proved so wearisome to both teacher and child that it was soon abandoned. Comenius was a man of far more practical character. He had early noticed the advantage of presenting to the mind of the child either the object concerning which he wished to instruct him or some representation of it, and the honor belongs to him of having been the first to prepare for the use of children a pictorial text book. This work (the "Orbis Sensualium Pictus," 1657) was not, like some of the illustrated school books at the present day, filled with pictures of battles or occurrences of history, but was a true cyclopædia of nature, fully illustrating, in a popular way, the natural science of the time, and his "Methodus Novissima," written as a guide to teachers in his new method of instruction, contains so much that is analogous to the "Manuals of Object Teaching" that it is difficult to believe that it was written two centuries ago. The following are a few passages taken from Hoole's translation of the works of Comenius, published in London in 1658:

"The ground of this business is that sensual objects may be rightly presented to the senses, for fear they may not be received. I say, and say it again aloud, that this last is the foundation of all the rest. Now, there is nothing in the understanding which was not before in the sense; and, therefore, to exercise the senses well about perceiving the difference of things, will be to lay the grounds for all wisdom and all wise discourse; which, because it is commonly neglected in schools, and the things which are to be learned are offered to scholars without being understood, or being rightly presented to the senses, it cometh to pass that the work of teaching and learning goeth heavily onward, and affordeth little benefit.

Descend to the very bottom of what is taught, and proceed as nature herself doth, in an orderly way, first to exercise the senses well, by representing their

objects to them, and then to fasten upon the intellect, by impressing the first notions of things upon it, and linking them one to another by a rational discourse. Missing this way, we do teach children as we do parrots, to speak things they know not what.

Since some things cannot be pictured out with ink, for this reason it were to be wished that things rare, and not easy to be met with withal at home might be kept ready in every great school, that they may be showed also as often as any words are to be made of them to the scholars. Thus, at least, this school would indeed become a school of things obvious to the senses, and an entrance to the school intellectual.

Pictures are the representations of all visible things of the whole world. Such a dress may entice witty children that they may not conceit (conceive it) to be a torment to be in the school. For it is apparent that children, even from their infancy almost, are delighted with pictures. And it will be very well worth the pains to have brought to pass that scarecrows may be taken away out of wisdom's gardens.

The good bishop goes on to explain the use and necessity of the blackboard, which he illustrates by a picture of that useful adjunct for illustration, explains the phonic method of teaching children to read, and inculcates the necessity of sympathy with the children, the necessity of evolving rules from illustrations, and, above all, the entire dependence of the teacher upon God's blessing for success in teaching. This "Orbis Sensualium Pictus," revised and modernized occasionally, was largely used as a text book in the schools of Germany till the close of the first third of the present century. In the next century, object teaching was again revived as a method of instruction, through the writings of Jean Jacques Rousseau, and the establishment of the "*Philanthropinum*" by John Bernhard Basedow (1728-1790). Basedow's "Elementary Book of Human Knowledge" (*Elementar Werk*) was in four volumes, with 100 plates, and its plan comprised—1st, elementary instruction in words and things; 2d, a method of teaching children to read without weariness or loss of time (this was essentially a phonic method); 3d, natural knowledge; 4th, knowledge of morals, the mind and reasoning; 5th, natural religion; 6th, a knowledge of social duties, commerce, &c. Basedow himself was a man of small culture, violent temper, and coarse manners, and in the latter part of his life grossly intemperate; but some of his assistants, among whom were Wölke, Campe, and Salzman, taught successfully on his system, and the school at Schnepfenthal, founded by Salzman in 1784, is still in existence.

The advocates of the method of object teaching now in vogue, profess to regard Pestalozzi (1746-1827) as the originator of the system. It seems, however, that most of the principles of their system had been set forth and developed by Comenius, and that Pestalozzi, in so far as he advocated what is to-day known as "object teaching," was but reiterating the system of Comenius. Pestalozzi, though a humane and generous man, had little originality, a meagre and desultory education, and no tact. For a few years past there has been attributed to him the origination of theories and systems of education which he would have been the last to

claim as his own inventions. In the *Elementar Werk* of Basedow, and the *Orbis Pictus* of Comenius, he had at his hand systems of instruction which he did little more than to adapt, and not always with success, to the circumstances of the children of his time. He was possessed of a kindly and affectionate nature, and in his intercourse with children came down to their capacities with great readiness. His principles of education were developed in his "Leonard and Gertrude." "How Gertrude teaches her children," and his "Book for Mothers," though no man ever departed more frequently from his own principles than he. The following statement, prepared by the late William C. Woodbridge, who had made himself most thoroughly master of Pestalozzi's system, will show what were the characteristics of that system:

"He laid down these principles: that education should proceed according to the laws of nature; that it was the duty of the teacher to assist this by exciting the child to self-activity, and rendering him only a limited degree of assistance; that progress should be slow and gradual, but uninterrupted, never passing to a second topic till the first is understood; that the memory and the understanding should not be unduly cultivated, but all the faculties developed in harmony; that the peculiarities of every child and of each sex should be carefully studied, in order to adapt instruction to them; that the elements of all knowledge were Form, Number, and Language, and that these elements should be taught with simplicity and thoroughness; that the art of observing should be acquired, and the perceptive faculties well developed; that every topic of instruction should become an exercise for the reflective powers; that mental arithmetic, geometry, and the arts of drawing and modeling objects of beauty, were all-important exercises for training, strengthening, and disciplining the mind; that the laws of language should be developed from within, and the exercises in it made not only to cultivate the intellect, but to improve the affections; that vocal music should be taught in schools, not by rote, but by a careful study of the elementary principles of music; that the Socratic method, as used by Basedow and others, is objectionable, and that in the early stages of instruction, dictation by the teacher and repetition by the scholar is preferable, and at a more advanced stage, the giving out of problems by the teacher, to be solved by the pupil without assistance; that religious instruction should begin with the mother, that the filial feelings of the child should be first cultivated, and directed toward God, and that formal religious instruction should be reserved to a later period, when the child can understand it; that despotic and cruel government in schools was improper, but that mutual affection between teacher and pupil was a better incitement to intellectual activity than prizes or other stimulants to emulation; and, finally,

that the exercise of the senses and the thorough cultivation of the physical powers were of very great importance to the complete development of the child."

Many of these principles were excellent, though not more than two or three of them (that in relation to despotic and cruel government in school being one) were new. There were, however, some practical defects in their application. The intellect was quickened, but very little positive knowledge was imparted, while the child almost inevitably gained the impression that he had made wonderful attainments; too high a place was given to language; mathematical and intuitive studies were given more than their proper share of attention, while other equally important studies were neglected; the process of simplification was carried too far and continued too long; repetitions were continued till they became wearisome; historic truth, and testimony as a source of knowledge, received but little attention, especially in religious matters, and religious knowledge was regarded as innate, rather than revealed.

Some of Pestalozzi's pupils and assistants, especially Neiderer, Schmid, Krüsi, Zeller, and Fellenberg, subsequently established schools in which they improved upon his theories. The Pestalozzian system, as it was called (though but a small portion of it was truly Pestalozzi's), was adopted extensively in the early part of this century in Prussia and the smaller German states, and in a modified form was introduced into France, Great Britain, and the United States. The improved Pestalozzianism introduced into this country mainly by the efforts of William C. Woodbridge, Thomas H. Gallaudet, William Russell, James G. Carter, Lowell Mason, and others, nearly thirty-five years ago, was divested of some of the absurdities of Pestalozzi's own theories, and was in many respects superior to any system of education previously attempted. The experience of Messrs. Gallaudet and Woodbridge in the instruction of deaf mutes had led them to see and avoid the fallacies of Pestalozzi's theory in regard to language, which he had formulated thus:—"Observation is the absolute basis of all knowledge; the first object then in education must be to lead a child to observe with accuracy; the second, to express with correctness the result of his observations." This second conclusion, every logician must see, does not follow from the premises. Pestalozzi subsequently says, that "out of the observation of an object the first thing that arises is the necessity of naming it." This necessity, a closer observation shows does not exist at all. A correct idea of an object can be, and is acquired, daily, where the object has no name, or its name is unknown to the observer; we might instance the position and relations of an unnamed planet, or the habits, locality, &c., of an undescribed plant or animal. The conception of an object by a deaf mute is none the less clear and perfect from the fact that he may not know the name by which it is called.

This zeal for loading the mind of the child with names for every object and for all the attributes of every object which falls under his observation, was deprecated by many of Pestalozzi's assistants and followers; and Fellenberg, Zeller, and Van Raumer, the ablest of them, entirely repudiated it.

In Germany, however, the evil results flowing from this predominance given to language, are, owing to the structure of the German language, far less injurious than they would be elsewhere. From the native roots, compounds and derivatives are formed by accretion of root words in common use, and early understood by the child, so that the attributes or qualities of objects are described in language which suggests its own meaning to the child. Thus where we should speak of the transparency of glass, for instance, the German word would be (literally translated) "through-seeness:" what we should call a hexagon, the German would describe as "six corners," a carnivorous animal in their vernacular would be "flesh-eating." Thus the mind of the child was not taxed, as it would be in English, with names of "learned length and thundering sound" derived from foreign tongues, and forming no part of the language of every day life.

In 1818, Dr. Mayo, of London, visited Pestalozzi's institution at Yverdon, and was so favorably impressed with his system that he resolved to introduce it into Great Britain. Dr. Biber and Mr. Greaves, who had also been at Yverdon, coöperated with him in the effort to accomplish his purpose. They introduced some modifications in order the better to adapt it to the English habits and modes of thought, but unfortunately the theory of language was adopted with all its faults, and with the additional objection, that owing to the idea apparently that the homely and expressive Saxon descriptive words, which would at least have had the merit of being constantly used within the child's hearing were vulgar, the more refined and classical words of Latin or Greek derivation were adopted; thus, if a peppercorn were the subject of the lesson, the child, instead of being told that its taste was biting or stinging, was taught that it was acrid or pungent; birdlime, instead of being sticky, was adhesive; an object without life was inanimate; a sourish apple was acidulous, and so on *ad infinitum*. In 1836, the "Home and Colonial School Society" was organized for the promotion of schools on this system, and a few years later established model and training schools from which about 3,000 teachers, a majority of them females, have been sent out. The apparent results from this method of teaching have been such as to attract attention, and to lead to its extensive introduction in Great Britain. In Toronto, Canada, it has been introduced into the normal and model schools. Dr. Mayo first, and subsequently his daughter, Miss Elizabeth Mayo, have prepared books of introduction for the teachers of the Home and Colonial Training

Schools, giving, with great minuteness of detail, the processes of instruction in all branches taught on the Pestalozzian system. The first of these works, published in 1853, was in five 8vo. volumes. A "Manual of Elementary Instruction," in two volumes, prepared by Miss Mayo, was published in 1861. In 1860, attention was called to this system of instruction in the United States by the publication, by Henry Barnard, in his "American Journal of Education," of a sketch of the Home and Colonial School Society's operations, and specimens of their mode of teaching. Several eminent teachers and friends of education, in visiting Toronto, had spent some time in the Toronto model schools, and witnessed the exercises of the primary classes trained under this system. Among them were E. A. Sheldon, superintendent of the city schools of Oswego, N. Y., and N. A. Calkins, of New York city. Mr. Sheldon procured the volume of instruction of the Home and Colonial Society, and very soon commenced training the teachers of his primary schools in the method of object teaching, and, deeming it desirable to have the teachers of the primary schools thoroughly trained by experienced instructors, sent to the Home and Colonial Society for a teacher. Miss M. E. M. Jones, an experienced instructor, was sent by the society, and has conducted for the past year a training school at Oswego. Mr. Calkins, having devoted much attention to the methods of the society, has, for a year and a half past given instruction in object teaching at Teachers' Institutes, &c., on the subject. The system has been introduced into the model schools of the State Normal Schools of New York, New Jersey, and Michigan, and into a portion of the primary schools of Syracuse, N. Y., Paterson, N. J., Chicago, Ill., Toledo, and Cincinnati, Ohio, Rochester, N. Y., San Francisco, Cal., and several smaller places. Mr. Sheldon and Mr. Calkins have both published treatises on the subject; Mr. Sheldon's being entitled "A Manual of Elementary Instruction, for the Use of Public and Private Schools and Normal Classes, Containing a Graduated Course of Object Lessons, for Training the Senses and Developing the Faculties of Children," New York, 1862; and Mr. Calkins's, "Primary Object Lessons for a Graduated Course of Development: a Manual for Teachers and Parents," New York, 1862. The following works on the subject have also been published: "Object Teaching and Other Methods of Primary Instruction in Great Britain," by Henry Barnard, LL.D., Hartford, 1861; "A Manual of Information and Suggestions for Object Lessons," by Marcius Willson, author of several popular school books, New York, 1862; "Object Lessons Prepared for Teachers of Primary Schools and Primary Classes," by A. S. Welch, Principal of Michigan State Normal School, New York, 1862. "Report of the Committee on the Primary Schools in the City of Oswego, N. Y., 1862." Several school books professedly

based on this system have also appeared in New York and Philadelphia.

Only a limited description of the processes adopted in the new method can be given in these pages, but a brief analysis of them may not be inappropriate, since the system is so actively propagated. The work of Mr. Sheldon must be the guide, as being more complete than any other, and being condensed from the manual of the Home and Colonial Training Schools, and with the assistance of two of the former teachers of those schools (Miss Jones and Professor H. Krüsi, a son of Pestalozzi's associate), is invested with a degree of authority which does not appertain to the other treatises.

The system of object teaching is by these writers and in practice applied to children between the ages of 4 or 5 and 12 years. The subjects on which lessons with objects are given are color, form, number, size, weight, sound, language, reading, dictation, geography, lessons on the human body, lessons on animals, lessons on plants, moral instruction, and drawing. Under form is included the elementary principles of geometry and writing, under number the simpler rules of arithmetic, under language the principles of grammar, and under lessons on the human body, animals, and plants, elementary physiology, zoölogy, and botany. The range of topics is thus sufficiently extensive to comprise the studies of public schools generally.

The rules for the teacher in giving instruction by this method require that the matter which is the subject should be stated, and the properties, nature, qualities and uses of it brought out by examination, the terms given and explained, the ideas developed from it, and illustrations and anecdotes respecting it narrated, and the whole impressed upon the memory by numerous simultaneous repetitions, and by writing and drawing upon the blackboard. Of course, in the different topics there must be considerable variations of detail, and much must necessarily be left to the skill and tact of the teacher, but the general order here indicated must be followed.

Children of the ages above specified are divided into four classes or steps according to age and intellectual capacity. With the youngest, the object of the teacher must be to exercise the perceptive faculties; with the second, a more minute perception is developed and the conceptive faculty called into action; with the third, the reasoning faculties are exercised, especially in the matter of distinctions, differences, and comparisons; while the perceptive faculty is still kept in activity, in the fourth, the imagination and the powers of analogy and generalization are developed.

The Phonic method of teaching reading, as prescribed in the "Object System," is peculiar, and many advantages are claimed for it. The letters are taught by means of cards and the blackboard, in the following order, *a, t, m, c, b, r, h, v, f, s, d, l, p, g, n, j, w, e, i, o, x, u, y, q, z*, and the combinations, *ou, oy, and th*. The

small letters are taught first, and only the short sounds of the vowels; the capitals are next taught, *C, K, O, P, S, U, V, N, X, and Z*, from their analogy to the small letters, and the remainder divided into three classes, *I, L, T, F, E, H, A, N, and M*, straight-lined letters; *Q* and *G*, curved line letters, and *D, B, R, and J*, straight and curved line letters. These letters are to be rudely imitated by the children with laths, and drawn on the blackboard. Meantime the child is taught to recognize by sight the words *the, is, his, this*, to aid in forming sentences, and combinations of the letters into words of one syllable, having the short sound of the vowels, are made. The children are exercised next, first on the long, double, and short vowel sounds, secondly on the consonant sounds, and third on rhyming sounds. In the second step, the children are introduced to words containing the long sounds of the vowels, and an additional list of words to be learned at sight, containing different sounds of the vowels; to words containing silent letters, and also to the sound of *K*, previously omitted, and the two sounds of *O* and *S*. They are also taught words having more than one initial or terminal consonant, and for the first time learn the names of the letters. Reading is commenced in a simple reading book, prepared by the Home and Colonial Society, and from this the teacher reads first word by word, the children repeating, and then the children read in the same way and the teacher repeats, and this several times; the same process is followed with each clause and finally with each sentence. Words having any peculiarity of spelling are selected and written upon the blackboard, sounds distinguished, and silent letters noticed. Next a single child is called upon to read the sentence or sentences in the same way, and the children are questioned on the meaning of the words, and the idea of the sentence. In the third step, the remaining consonants *g, th, ph, gh, ch, z, and x* are considered and their sounds taught by examples and analogies; diphthongs and other anomalous sounds are also distinguished, and the children exercised in reading as before, though in lessons of longer and more difficult words. It is impossible to concur in the commendations bestowed on this method of teaching to read. It seems faulty in instructing the child vowels before consonants, letters before words, and compound sounds before simple ones.

Those who desire more full descriptions of the system will find them in the treatises above named. It is not surprising that so many prominent teachers should have eagerly seized upon this system. The teaching of very young children, always a matter of difficulty, had never been managed with much method, and with but a moderate degree of success; and routine, fatal here as everywhere else, had deprived the best of the plans in use of much of their vitality. The *Kinder-garten* system, though in many respects admirable, was encumbered with too many and too expensive arrangements



of building grounds and apparatus, and required too long and thorough training of the teachers, to come into general use. Here was a system, requiring, indeed, the possession of considerable talent, tact, education, and imagination on the part of the teacher, but rendering routine impossible, and promising showy and brilliant results.

**ELECTRICITY.** In connection with the progress of electrical discoveries and theory, the feature of most absorbing interest at the present time, is that of the several propositions and attempts toward establishing certain fixed units of measurement for various electrical quantities, and particularly—1, for the electro-motive force of a galvanic couple or battery, *i. e.*, the total force of current the couple or battery could generate if the resistance opposed to the passage of such current through the conducting wires or circuit be nothing or inappreciably small; 2, for the resistance opposed to the current by the necessarily imperfect conducting power of the wires or material of the circuit; 3, for the actual intensity of the current produced, as a result of the given electro-motive force diminished by the given resistance. The determining of such units, as leading in time to the ability to estimate accurately and compare the electrical quantities of batteries and circuits of all sorts whatever, and those requisite to the various effects which currents are expected to produce, is at once seen to be a problem the solution of which promises results of the highest practical value. In the applications of electricity during the past year, although perhaps no great or striking achievement has been made, some points of interest nevertheless present themselves. (*See also AURORAS, METEOROLOGY, and TELEGRAPHY.*)

**I. SCIENTIFIC PROGRESS.**—*Measures of Electric Resistance.* To determine comparatively the resistances of different circuits, Mr. Siemens had proposed that the standard or unit should be a filament or minute column of mercury of given length within a tube, and from the two ends of which connections with the two poles of a galvanic element or battery should be made: a needle or other galvanometer introduced in the course of the same circuit would show the intensity of current when the mercury filament is, and when it is not, made part of the circuit, and would thus give the resistance of the given length and diameter of that metal as a conductor. An objection to this plan is, that after a time alloy of the mercury from the ends of the solid metal conductors must occur, thus changing the actual conducting power of the filament, and again, that the contact of the solid wires with the metallic mercury is uncertain or of variable degree. To obviate these difficulties, as well as certain imperfections in Wheatstone's electro-motive balance, Prof. W. Thomson has devised a new electro-motive balance for determining resistances of short bars or wires, and by use of which he considers that no uncertainty in the

connections can exist, even though these are not made with extraordinary care. He concludes, however, that in order to arrive at the most accurate possible system of electrical measures, the standards that may be adopted must first have been exchanged between and compared by different experimenters. For the details of the paper, which is long and mainly theoretical, the scientific reader is referred to the proceedings of the Royal Society, or to the "*Philos. Magaz.*," Aug. 1862.

*Matthiessen's Unit of Resistance*—is that opposed to perfect conduction of an electric current by a wire composed of 2 parts by weight of gold and 1 of silver, length 1 metre (39.37 in.), diameter 1 millimetre (.03937 in.). The author's experiments lead him to conclude that this alloy conducts electricity with nearly the same facility at all temperatures between 82° and 212° F.; that impurities in small quantity do not sensibly affect its conducting power; and that the annealing of the metal also makes no sensible difference. The wire should be varnished to protect it from action of mercury. (*Pogg. Annalen*, cxii, p. 853). Prof. W. Gibbs suggests that the specific conducting power of such a wire may, as is known to be the case with copper, undergo change from continued or repeated use.

*Weber's Proposed Absolute Standard.*—The student of mechanics well knows that having the measures of space and time, no specific fundamental measure of velocity is required; since we find or express velocity by the simple ratio,  $\frac{\text{space}}{\text{time}}$ . Weber calls attention to the fact that, in like manner, if there are measures for electro-motive force and actual intensity of current, no specific fundamental measure of electric resistance is necessary; the resistance that exists in a closed current in which the unit of electro-motive force produces the unit of intensity, being taken as the unit of resistance. Now, in Gauss's treatise on the "Intensity of the Earth's Magnetic Force" (Göttingen, 1833), absolute measures for terrestrial magnetism and for bar magnetism are given. Weber shows that from these an absolute unit of measure of electro-motive force and a like unit of intensity of current can be obtained—these being expressed and known in the three simple elements of space, time, and mass (of the conductor). In some experimental applications of his principle, employing a copper wire 3,946,000 millimetres in length, and of a mass equal to 152,890,000 milligrammes (about 888 lbs. avoird.), Weber calculated the absolute measure of resistance at 190,000,000 units, and the specific resistance of the material at 1,865,600 units. ("*Philos. Magaz.*," Sept. and Oct., 1861.)

*Electro-motive Force of Voltaic Piles.*—M. Marie Davy believes that, however carefully the units of resistance and of current may be defined, since these are arbitrarily chosen, it still cannot be hoped that from them we can so estimate the electro-motive force of batteries as directly to furnish the calorific value, or

equivalent in heat, of the chemical actions taking place in those batteries. What is really required is, to determine in numbers some constant unit or coefficient for the force considered, and which could be easily obtained by each chemist. The most simple of batteries is Smee's—the only chemical action normally going on in this being the oxidation and solution of zinc in the acid, with disengagement of hydrogen. The value of the heat corresponding to this action was carefully measured by M. Favre, and expressed by the number 18,444 for ordinary zinc, and 18,791 for zinc amalgamated. In preliminary researches with the battery named, including 125 determinations of its electro-motive force, M. Davy found variations in this force between 16,886 and 20,604, a difference of 2 per cent., where he had been led to expect no more than that of  $\frac{1}{1000}$ th part. The researches resulted in showing 7 causes of disturbance acting within the cup or battery, and leading to variations in the current force which, independently of all influences outside itself, it can generate. Of these, the most important appeared to be the presence of air in solution in the acidulated water, and the influence of the sulphate dissolved in the liquid during action of the battery; the oxygen of the former acting directly on the zinc, and preventing to a corresponding extent the decomposition of the water, and both causes operating to diminish the electric force of the battery. The third cause of disturbance was the influence of concentration of the acid, the force generated however being constant so long as the acid solution contained more than 25 equivalents of water for 1 of acid. The other influences were, that of purity of the zinc and state of the amalgam—the electric force from amalgamated zinc being generally stronger; that of purity of the acid—the nitrogen compounds often present in it increasing the strength of the current; that of the water—distilled water being preferable; and that of temperature, which causes considerable variation in the current generated.

Finally, in order to secure results under uniform conditions, M. Davy works a Smee's battery consisting of a plate of platinized platinum immersed vertically in a mixture of sulphuric acid with 8 to 10 times its weight of distilled water, boiled to free it of air, this solution being placed in a vertical glass tube, at bottom of which is a liquid amalgam of pure zinc in pure mercury. A platinum wire traversing the bottom of the tube forms the negative pole of the element, the glass tube containing the arrangement is immersed in a large vessel full of water, which keeps the temperature constant, the liquid of the cell being also frequently changed. Fixed resistances in platinum of known temperatures being introduced into the circuit, serve to show the corresponding variations in intensity of the current. M. Davy takes for the electro-motive force of this pile the number 18,510. ("Philos. Magaz.," July, 1862.)

*Measures of Electrical Quantities.*—Mr. Latimer Clark and Sir Charles Bright presented before the British Association, 1861, a paper on the principles which should be observed in measuring electrical quantities and resistance. They believe that four standards or units are in reality required, these being mutually dependent on each other; and that by the aid of these every conceivable form of electrical manifestation, whether static or dynamic, can be precisely expressed. These are:

A. A unit of electrical tension, potential, or electro-motive force.

B. A unit of electrical quantity, as applied to static electricity.

C. A unit of electric current, or quantity in dynamic electricity.

D. A unit of electrical resistance.

As the unit of tension they propose that of one Daniell's element or cell, to be named 1 *Ohm*. As the unit of quantity of static electricity, they propose that corresponding to a tension of 1 Daniell's element existing between two coatings oppositely charged, the coatings being 1 millimetre apart, of 1 square metre surface, and separated by dry air; this quantity to be termed 1 *Farad*. As the unit of current, they propose that of one unit of quantity per second delivered along a conductor, as determined by the galvanometer; this to be known as 1 *Galvat*. But the wire that will conduct 1 unit of electricity in 1 second becomes conversely the standard or unit of resistance, this to be known as 1 *Volt*. Of these units, the first three will in practice require to be measured in multiples of 1,000 and 1,000,000 times the unit—indicated by the prefixes *kilo-* and *millio-*; the fourth, as too large for defining the resistance of telegraph conductors, will require to be measured in fractions of the unit—indicated again by the prefixes *kilo-*, *millio-*, and *billio-*. A synopsis of the paper at greater length is given in the "Journal of the Franklin Institute," February, 1862.

*Report on a proposed Standard of Electrical Resistance.*—Mr. F. Jenkin, on behalf of a committee appointed by the British Association to consider this subject, reported at its last meeting. In such a standard five qualities are desirable; it should be of convenient magnitude; should form part of a general and coherent system of electrical measures; should bear a definite relation to the unit of work; should be unalterable; and should be reproducible, if accidentally destroyed. Of the units hitherto proposed, the committee conclude that none fulfil all these conditions. Those based on an arbitrary length and section, or weight of some material arbitrarily taken, lacked the first and second qualifications; the absolute system possessed these, but failed in the third and fourth; and the system of Messrs Bright and Clark also failed in the third particular. Not being able to advise the unqualified adoption of any of the previously proposed standards, the committee recommend that a material

standard be prepared, and of such substance and form as to insure the most absolute permanency. The aim should be to make this standard correspond to a current force equal to 10,000,000,000 times the value given by the quotient of 1 metre by 1 second of time, that is,  $10^{10} \frac{\text{metre}}{\text{seconds}}$ ; and to this it should approximate as nearly as possible. Such a unit would not differ more than .08 for Dr. Siemens' mercury unit. It should not be called an absolute unit, but simply the "unit of 1862;" and it should not be constructed at all until a very close approximation to the absolute value was supposed to have been attained, and great permanency in the material standard secured. Then, as the advance of science showed more and more truly the actual deviation of this from the true unit intended, corrections could be made by experimenters in their results when required. The material standard itself, however, should under no circumstances be altered in substance or definition.

*Influence of Temperature on the Conducting Power of Metals.*—Matthiessen and Van Bosc presented before the Royal Society a paper on this subject, Jan. 16, 1862. They find that, contrary to what has been stated by Becquerel, Siemens, and others, the conducting power or the resistance of a metal for an electric current, does not increase or decrease in a direct ratio to the temperature, but in a ratio much more complex. All pure metals in the solid state, however, vary in conducting power to the same extent between the temperatures of 32° and 212° F. Wires of the same metal behave differently after being kept for some days heated to the same degree. Metalloids generally conduct better when heated than when cold; this is true of selenium, gas coke, graphite, and the gases.

*Mechanical Effects of Powerful Tension.*—M. Faye exhibited before the Academy of Sciences, Paris, an experiment in which two plates of crown glass, respectively nearly 1½ and 2½ inches thick, were completely pierced through by the electric spark of the great induction machine recently constructed by M. Ruhmkorff. The path left by the spark is seen to consist of a white and opaque fillet, extremely slender, its whole length presenting bright places at slight distances, and taking different directions in the manner of the parts of a spiral. It shows no metallic deposit. In the thicker plate, at a depth of about ½, the track bifurcates; and near to the opposite face, it subdivides into many and more direct fillets. During the experiment, Ruhmkorff demonstrated by the appearance of Haidinger's colored rings, that the passage of the spark was accompanied by an energetic compression of the substance of the glass; but no trace of fusion appeared about the course taken by it. M. Faye thought nevertheless that, by passing the spark of this machine through some pulverulent substance somewhat more fusible than crown glass, true fulgurites could be produced.

*Study of the Electric Spark by Aid of Photography.*—Prof. O. N. Rood, of Troy University, N. Y., has been, by aid of a new and very neat method devised by him, studying the form and characteristics of the electrical spark. The photographic images of the electric spark hitherto obtained by Prof. B. Silliman, jr., Prof. W. B. Rogers, Feddersen and others, have been taken from a position at right angles to the course of the spark, thus furnishing a side view of it; and they have usually required a prolonged exposure of the sensitive surface to the light; in some instances from 3 to 6 minutes. Prof. Rood's method is that of receiving the spark directly upon a sensitive or properly prepared surface, and subsequently developing the figure produced, in the manner of photography. In this way he secures the figure corresponding to a single discharge of ordinary or frictional electricity, the brief duration of which has forbidden its being photographed by previous methods. His plan is an application, first, of Becquerel's discovery that paper coated with bromide of silver is sensitive to the electric spark; and, secondly, of his own observation that, in instantaneous photography, the portions of the sensitive surface immediately contiguous to those acted on by the strong lights, still remained quite unaffected by the exposure. Upon testing the fact in case of a single electric spark, he found that an intense and sharply defined image, full of delicate details, was here also the result. The question whether these images were due to direct action of the electricity itself, or to the agency of the light evolved, appeared to be settled by certain experiments, especially by the fact that when the spark was received on a thin glass plate, placed over another coated with sensitive collodion, the electric image could be developed, though less sharply defined, on the second plate; but when the first or thin glass was blackened, no image on the second resulted, from one or a number of discharges. The form of apparatus given for these experiments is simple; the collodion recommended is that suitable for ambrotyping, and when freshly prepared.

The general form of the positive electrical spark ascertained, is a combination of two figures: a star and one or more rings, all having nearly a common centre. The rings are usually quite within the limits of the star, sometimes one of them without it; and when two or more rings appear, they are successively darker toward the centre. The marked differences in form of the two components, and the fact that the annular form is characteristic of the electric brush, seem to indicate that each simple spark consists of two or more successive discharges of varying intensity. When, owing to distance, or to the use of a pointed wire, the partial sparks become more uniformly blended, the electrical "brush" is the result; and the figures confirm the general view of electricians on this point, by showing how the former passes

by insensible gradations into the latter. The form of the negative spark differed greatly from that of the positive, being destitute of rays, generally circular in shape, and often made up of a number of minute circles placed without symmetry. For like distances it was also larger than the positive, and never nearly so well defined. Moreover, there is a general resemblance between the positive and negative figures as thus obtained, and the figures of the corresponding sorts obtained by Lichtenberg and Riess by passing the sparks to a surface sprinkled with powdered sulphur and red lead, and known as "Lichtenberg's figures."—"Amer. Jour. of Science," March, 1862.

*Production of Vibrations and Musical Sounds by Electrolysis.*—If a large quantity of electricity be made to pass through a suitable good conducting electrolyte into a small surface of pure mercury, especially when the latter is disposed in a narrow band or ring, strong vibrations will occur, the surface of the mercury being thrown up into numerous crispations or minute ridges running in a radial direction, this appearance being often accompanied with definite musical sounds, and which can sometimes be heard to a distance of 50 feet. The best electrolyte or liquid employed to conduct the current (while undergoing decomposition by its action), is formed by dissolving 10 grs. of cyanide of mercury and 100 grs. of hydrate of potash, in 2½ oz. of aqueous hydrocyanic acid, containing .05 of the anhydrous acid. The vibrations and sounds occur only at the surface of the mercury, which serves as the electrode. The only liquids giving the phonetic vibrations were solutions of alkaline cyanides, containing dissolved mercury (in combination), and these only when the electrodes, or at least the cathode (positive pole) was of mercury. The vibrations and sounds vary considerably according to the size and number of the voltaic elements. With a few cups only in the battery and the plates of large size, the vibrations were rapid and the tone high; with many pairs of small plates, the vibrations were less frequent and the tone low. The most suitable number of elements appeared to be 2 of Grove's, or 5 of Smee's battery. By interposing in the circuit made a coil of stout copper wire, the sounds became more bass, still more so upon thrusting an iron coil suddenly within this; but if, in either case, a secondary coil with its ends united were made to surround the former, the sound returned to the higher pitch and preserved it so long as the outermost coil remained in place. A strong electro-magnet placed in various positions in the neighborhood of the vibrations had no influence in the way of changing or arresting them. The phenomena were readily produced by connecting with the positive pole of the battery a circular pool of mercury 1 to 3 inches in diameter, and surrounding this with a ring of the same metal about ½ in. wide, connected with the negative pole; the liquid metal being contained in suitable glass

or gutta percha vessels, and covered with the solution to the depth of half an inch. Mr. G. Gore, by whom these investigations have been conducted, regards the vibrations as having an electro-chemical origin, and as resulting from an attraction between the mercury of the negative electrode and the mercury of the electrolyte.

*New Experiments in Electro-Magnetism.*—M. Leroux, of the Polytechnic School, Paris, having a platinum wire about  $\frac{1}{16}$  of an inch in diameter, and 7 inches or more in length, rendered incandescent by being made part of an electrical circuit, presented the wire in this state and properly flexible to the poles of a powerful magnet or electro-magnet: the wire assumed a series of configurations, depending on the direction of the current and whether the line joining its extremities has a position axial or equatorial with reference to the magnet. Such a wire was attracted by a mass of iron, especially if the latter presented a large surface, a counterpart of Arago's experiment that a wire traversed by a current attracts iron filings. Leroux also showed how a fine conjunctive wire could be made to coil itself spontaneously around the pole of a magnet. Having fixed upon one of the poles of a horse-shoe magnet an armature of soft iron, about 4 inches in length, turned and polished, he attached to this armature the extremity of a silver wire, holding the other extremity in his hand, but so loosely that the wire could constantly obey the forces which solicited it. When this wire was then traversed by a current, it coiled itself around the armature, and there formed a helix wound in a direction opposite to that which would be required to give to the armature the same magnetism it already possessed. This experiment is more conveniently performed by having the wire at first coiled on a small metallic bobbin suspended above the magnet; and the more constant the length of wire traversed by the current, the less is the risk of burning it. Thus is found a new kind of motion obtained by the action of the pile. To prevent the undue acceleration of this motion, a smaller cylinder may be fixed on the axis of the bobbin, from which a small weight at the end of a silk thread draws in the direction opposite to that given to the bobbin by the uncoiling wire. For these experiments a current of about 10 Bunsen's elements was employed.

*Electricity Developed during Evaporation and Effervescence.*—Prof. Tait and Mr. Wanklyn have, by use of the extremely sensitive and accurate divided ring electrometer of Prof. Thomson, investigated the phenomenon of development of electricity by evaporation of certain liquids, during the few moments in which on quitting the "spheroidal state" in a heated capsule or dish, and coming again in contact with its surface, they emit the well-known "fizzing" sound attending their rapid evaporation at that period. By conducting wires suitably arranged, in course of which the electrometer was placed,

the strength of the charge generated could be estimated, and this is numerically expressed for the various liquids so examined, 5.8 being taken to represent the electro-motive force of a single Grove's element. The generated charges in case of some of the substances examined were as follows: Bromine, +400; iodine, +90; ammonia, -200; alcohol, -10; mercury, -75; water, -80; strong solution of common salt, -400; caustic potash, +150; strong nitric acid, +7.5; benzole and valerianic ether, no effect. From a like series of experiments on the development of electricity during brisk effervescence of different liquids, the following results were obtained: with solution of zinc in hydrochloric acid, -750; solution of binoxide of manganese in hydrochloric acid, -150; solution of common salt in sulphuric acid, +10. ("Proc. Roy. Soc. Edinb.," Feb. 1862.)

*Experiment with the Crural Nerve of Frog.*—In this experiment, one of the first by which Galvani was enabled to lay the foundation of that branch of electrical science now very commonly bearing his name, of the two metals employed one was made to touch the nerve of the frog's leg, the other at the same time the muscle; and in the directions for repeating the experiment, this is the arrangement usually laid down as requisite. If, however, the upper end of the nerve be dissected out from the thigh, and the metals be so placed that both shall be in contact at one of their extremities with this part, so that the current shall pass through the nerve alone, the muscular contraction and movement of the leg are equally great. The experiment in this form is conveniently performed by winding the separated or free end of the nerve around one wire of a galvanic cell or element, and then touching with the other wire any other point in the exposed nerve, so as to pass the current through the intervening portion. If the second wire touch the muscle, this serves as a conductor, and the contractions follow of course; but the preceding experiment appears to show that the effect is due in reality to passage of the current along a portion of the nerve.

*Electrical Phenomena of Vesuvius.*—M. L. Palmieri first observed at the distance of a few hundred yards the flashes of volcanic lightning from a new crater of Vesuvius, at Torre del Greco. These flashes appeared always to originate in large globes of smoke, and they were followed by explosions not louder than the reports of pistols. Afterward, from the observatory he noticed similar flashes between smoke and cinder masses below and bodies of aqueous vapor above these; but very seldom between the smoke masses and the earth beneath. At each violent projection of smoke, his instruments indicated a strong tension of positive electricity; and when this reached a certain force, lightning and thunder occurred. If the electric discharge occurred in the direction of the zenith of the place, a sudden increase of

positive electric tension was the result; while, if the discharge was directed toward the earth, or to a distant region of the air, the tension became negative. The vapor which moved toward the observatory, if free from cinders, was strongly positive; but the cinders which fell when the smoke of a superior current deviated from the zenith were negative.

II. APPLICATIONS.—*Ritchie's Electrical Machines.*—The principle of induction holds true for current as well as for common electricity; illustrations being found in the facts that if a wire or coil be made to transmit a galvanic current while another wire or coil is situated in immediate relation with this, but not so as directly to receive the electricity from it, and if along the first wire or coil an interrupted or periodically reversed current be transmitted, then at every such interruption and recommencement, or reversal, of the primary current, a secondary or induced current will be developed in the second wire or coil; and this induced current will partake in a large degree of the properties of common electricity, having great intensity, and being capable of discharging itself to a corresponding distance through dry air or other non-conductor—a power of which the primary or inducing current is wholly destitute. If, further, the electrical condenser be added at the extremity of the second wire, so as to intensify the charge arising in it at the moments of interruption, the intensity and mechanical effect of the induced current are still further increased. These principles were determined by the researches of Faraday, Henry, De la Rive, Fizeau, and others.

M. Ruhmkorff, of Paris, was the first to produce an actual combination or machine representing and taking advantage of these principles. This machine, known as Ruhmkorff's induction coil, consisted essentially of an inner helix of shorter and larger copper wire transmitting a current from a galvanic battery, with the addition of an interruptor to break the current at regular intervals, this helix being surrounded by and insulated from a second of finer wire and much longer, having at one end the condensing plates, and the extremities of which constituted the poles of the secondary current. With his arrangement the longest spark obtained did not quite equal one inch in length. Mr. Hearder, in 1857, improved the apparatus by more carefully insulating the helices, and obtained sparks of 3, and subsequently of 6 or 7 inches.

Mr. E. S. Ritchie, of Boston, Mass., desiring in the same year to produce the induction coil and of increased power, found it impossible to construct it in the ordinary manner and yet free from liability of the breaking through of the spark from one coil to the other—a casualty that at once destroyed the action of the machine. His experiments led him to adopt an entirely new plan of winding the exterior coil, consisting finally in winding this wire in planes

perpendicular to the axis of the helices, alternately running from the inner to the outer and from the outer to the inner diameters of the outer helix, and very carefully insulating not only between these strata but also between the inner and the outer helix. By these means he had in July of the year named produced an instrument giving sparks of 9 to 12 inches in length. Meanwhile, M. Ruhmkorff's best improved instruments had failed to give sparks of more than 3 or 4 inches in length. In the summer of 1858, Prof. R. S. MacCulloh, of Columbia College, N. Y., having secured for that institution one of these coils which, with a battery of only 4 Bunsen's cells, gave a spark 12 inches in length, ordered also one of Ruhmkorff's for which the French Academy had just awarded him a prize, and informed him of the power of Ritchie's machine, as also of the readiness professed by the latter maker to surpass the power of any instrument that might be so furnished. Receiving in the mean time no instrument from Paris, Prof. MacCulloh, in May, 1859, while on a tour in Europe, visited M. Ruhmkorff, who expressed an unwillingness to produce an instrument upon the conditions named, but showed one which he had attempted, and which had destroyed itself by the breaking of the spark through the insulation. Prof. MacCulloh, supposing that Ruhmkorff would be glad to compare Ritchie's instruments with his own and those of Hearder, and that he would of course accord due credit for what was original in the first named, presented him with one of these giving sparks of 7 inches. This M. Ruhmkorff dissected, for the purpose of examining its construction. About the same time, Prof. MacCulloh ordered of Ritchie the most powerful coil he could make, to be sent to Paris. Being received in November, this instrument and its performance were by him exhibited before Jacobi, Foucault, Duboscq, Jamin, Déssins, Froment, and others distinguished in electrical or general physical science, as well as before the students of the École de Médecine, and several professors of the Polytechnic School. M. Ruhmkorff, meantime, had a long-unfulfilled contract for a powerful coil for the last named school; and M. Jamin expressed himself in favor, in case such instrument should not be delivered by the close of the term of contract (March, 1860), of procuring one of Mr. Ritchie's instruments. In March, however, Ruhmkorff delivered to the school an instrument of his construction; and Prof. MacCulloh, on seeing this coil in May, was informed by M. Jamin that it was wound in portions perpendicular to the axis (Ritchie's system), and that it gave sparks of about the same length as the most powerful instrument of the latter, namely, 18 to 16 inches. M. Ruhmkorff showed to Prof. MacCulloh in June another instrument of like power, and of which he declared the construction to be similar. These facts are chiefly drawn from an account furnished to Mr. Ritchie for publication, by Prof. MacCulloh, since

his return. The French scientific writers and journals, however, seem uniformly to ignore Ruhmkorff's indebtedness to Mr. Ritchie for an improvement which has fully tripled the power of the machine over that of any constructed by the previous methods; and they unite in awarding to the Parisian maker the entire credit of the invention of another. The Abbé Moigno, editor of the *Cosmos*, relates witnessing about the beginning of 1862 an experiment with one of Ruhmkorff's coils, which gave a spark 18 inches long, and pierced glass of two inches thickness. (See *Mechan. Effects, &c.*, previous.)

*Conducting Power of Pure and Alloyed Copper.*—Matthiessen and Holtzmann have presented before the Royal Society a paper on the effect of the presence of metals and metalloids upon the electric conducting power of pure copper. The variations in conductivity of copper wires as found by different experimenters, must depend in part on differences of quality and purity of the wires experimented with, and in part, at least, also on differences in temperature. Thus, taking the conducting power of pure silver as = 100, the following are the measures for copper as found by the physicists named:

Becquerel.....	95.3	Harris.....	100.0
Riess.....	67.2	Buff.....	95.4
Lenz.....	78.4	Pouillet.....	78.0
Davy.....	91.3	Arndtsen.....	98.7
Christie.....	66.0		

The temperatures at which the determinations were made are given only in the cases of Becquerel, Lenz, and Arndtsen, namely, 32°F. Matthiessen and Holtzmann prepared pure copper, both by a method involving precipitation with sulphuretted hydrogen from the purest commercial sulphate of copper, and also by precipitating the metal galvanoplastically by a very weak current from the same compound. The conductivity of a hard-drawn silver wire being taken as = 100, the mean of 12 determinations of hard-drawn wires from the copper so obtained gave for this metal 98.08, at 18.9° C. With similar wires annealed, there was a gain of 2.5 per cent., the mean in this case being 95.58. Copper fused in the air is probably always contaminated in degree with oxygen which it absorbs, producing some quantity of the suboxide; and the presence of this impurity was found always to reduce the conducting power, and in some cases to as low as from 69 to 73 in the scale. The experimenters could not induce the taking up by copper of more than .05 per cent. of carbon; but even this reduced the conduction to 74.91, at 18.3° C. Phosphorus, sulphur, selenium, and tellurium all very considerably reduced the conducting power of copper into which they entered as impurities; and arsenic in a still more remarkable degree—5.4 per cent. of arsenic giving a mean conducting power of only 6.18, at 16.8° C.; and 2.8 per cent., of 18.14, at 19.1° C. Of all the metallic impurities tin and iron most sensibly lowered the conducting power, the former, in amount

of 4.9 per cent., to 19.47 in the scale. In conclusion, the authors state that they find no alloy of copper which conducts electricity better than pure copper; and they call the attention of experimenters to the importance of stating in future determinations whether the wires they employ are hard drawn or annealed, and at what temperature the observations are made. A more full abstract of the paper appears in the "Jour. of the Franklin Inst.," for May, 1862.

*Electric Lights for Lighthouses.*—Mr. J. K. Whilldin, C. E., communicates to the journal just quoted (April, 1862), an article relative to Prof. Way's electric light, with mercury, and to the arrangements for projecting lights generally. Before entering upon the topics treated of by him, it may be remarked that the introduction of the electric light for lighthouse purposes appears to have been directly owing to the demonstrations by Prof. Faraday, in connection with Prof. F. H. Holmes, of the practicability of its use, and especially to the experimental exhibition of its capabilities in the South Foreland lighthouse, near Dover. The electric light is obtained by heating to incandescence, by means of the passage of an electric current between or through the bodies so employed, carbon points, which are made to terminate the positive and negative conducting wires of a battery, or a slender filament of some metal introduced between the ends of the wires. In the former case incandescence of the points can be produced only when these are brought very close together, but usually not into positive contact; in the latter, the light is the result of the intense heating of the fine wire owing to the low conducting power it possesses for the current. In either case, a current of very high intensity is usually required; and this may be obtained either from a galvanic battery of many cells, say from 40 to 100, or from the magneto-electric machine. The suffocating nitrous fumes generated during action of a Bunsen's battery, and indeed, the expense of materials and the attention required in order with any form of battery to maintain a regular and intense current, constitute serious objections to their employment. Prof. Faraday gave preference to the electro-magnetic machine, as being both a less troublesome and a more economical source of electricity than any galvanic battery. At the present time both are, in different places, in use. The current of the electro-magnetic machine is instantly produced upon giving a rotary movement to the mechanism, regular while the movement is kept up, and at once discontinued, without waste, when it ceases. Its use thus involves the addition of some motive power; so that where a steam engine is required for other purposes, this mode of producing the current is readily and inexpensively resorted to. Where such an engine is not present, Mr. Whilldin suggests the economy and advantage of Ericsson's hot-air engine.

Mr. Whilldin calls attention to the great cost of the Fresnel lenses now generally employed for projecting the lights, of whatever kind; those of the first order, as at Cape May, Hatteras, &c., 6 ft. diameter by 9 ft. high, costing from \$5,000 to \$11,000. By employment of the electric light he judges that for these an apparatus not costing more than \$400 to \$500 can be substituted. Faraday, indeed, states that all the light from an electric lamp could be utilized within a space not exceeding the size of an ordinary hat, a result that, if practicable, would reduce the cost yet more. The difference and saving arise mainly from the diminution allowed in the size of the very costly lens arrangements, as the electric light is produced almost at a point; while to augment the intensity and penetrating power of the common oil lights, the number of the burners and the space occupied by the flame must be very greatly increased. With the electric light, increase of brilliancy involves increase of battery power, and so of expense in this way, but with no enlargement or inconvenience in respect to the lenses.

The electric light hitherto most commonly employed for lighthouses, has been that of the carbon points. In this system the difficulties practically encountered have been chiefly those of obtaining the carbons sufficiently free from impurities and variations of compactness to preserve a uniform current and brightness, and so to maintain the proximity of the points by clockwork or other automatic mechanism during their slow but continued waste, as to prevent interruptions of the current from this source, either through too great distance or absolute continuity of the carbon electrodes. Prof. Holmes' magneto-electric light, however, with carbon points, appears from evidence in a late parliamentary report to have been successfully used in the South Foreland lighthouse, England, during a period of 6 consecutive months. In France, also, magneto-electric lights are in successful use; and though there the system is peculiar in the respect of continually reversing the current, no important difference in the two lights has been detected.

By means of dark glass, Prof. Faraday compared the electric light with that of the sun: the latter was not at the time at its brightest, but the intensities of the two lights were about equal. He says that the eyes of the keepers of the South Foreland light are not affected, though protected by blue glasses of very pale color; but that they judge better of the light by observing the place and intensity of the rays within the lantern, than by looking at the light itself. In some experiments on lights in France, the intensities of an argand burner and of the electric light were found with approximate correctness to be as 1 and 94; and that of the "first-order flash" of the former being 80 to 90, that of the "cast-glass flash" of the latter was placed at 55,000, and of the "first-order flash" at 220,000. The electric light is particularly valuable for its power to penetrate a thick,

hazy atmosphere; and sailors on board steamers have declared that in such weather Prof. Holmes' light is seen 7 miles farther than any of the ordinary sorts. A practical difficulty at the same time growing out of the great intensity of the light, is said to be that navigators cannot readily judge of the distance of the shore or point from which the light proceeds.

Prof. Potter, of London, is led by extensive photometric experiments to question the superiority of the dioptric system over reflectors; in other words, to doubt the advantages claimed for the Fresnel lenses. He finds that in passing through 2 inches of clear flint glass with highly polished surfaces, about  $\frac{1}{4}$  of the light is still lost by reflection and absorption; while ordinary good looking-glass reflects from  $\frac{1}{7}$  to  $\frac{1}{8}$  of the incident light, and highly polished speculum metal still more. Faraday considers that the dioptric apparatus absorbs not less than 50 per cent., while pure polished silver reflects .95 of the total incident light. Sir J. F. W. Herschel has recently proposed an improved reflector, which is expected to prove a great economizer of light. In this, he would render available Liebig's recent discovery of the means of precipitating pure silver from its solution, contained in a thin shell of glass: the silver, protected from all agencies that would tarnish it, is said to reflect .91 of the light impinging on it. It is proposed to use mirrors of this sort, and in forms intended to prevent the partial dispersion and waste of light which occur with the parabolic reflector; namely, by placing a hollow hemispherical reflector above the light, and a peculiar conoidal (convex) reflector below it, the arrangement being such that all the light reflected above the level of the source is thrown back, and with that falling below the horizon, also, is then thrown off from the lower reflector in horizontal beams. With this arrangement, as with the dioptric, the entire horizon can, if desirable, be illuminated. Cuts of the arrangement for the mercury light and the form of the proposed new reflector accompany the article from which the facts detailed in this section are in good part taken.

*Way's Electric Light, with Mercury.*—In the autumn of 1861, Prof. Way visited this country and made several exhibitions of his electric light, one of these being (by aid of a Fresnel lens of the 4th order, loaned for the occasion) from Fort Washington, near Washington, D. C., the signals being witnessed by the President and others from the "White House," a distance of 18 miles.

This light is produced by means of a fine thread of mercury kept flowing in the position answering to the focal point of a suitable reflector or Fresnel lens, this mercury being at the same time rendered intensely luminous by the continual passage through it as a conductor of a strong current of electricity. The mercury flows from an upper reservoir, through a tube with a very fine opening, into a lower one. The positive and negative wires com-

municate with the mercury in the respective reservoirs; and the circuit is complete only so long as, by the opening of a stopcock, the mercury is allowed to flow. The current is usually generated by a battery of about 45 Bunsen's elements.

In the production of the recent and somewhat famed *magnesium* light, a continual consumption of the fine thread of the metal goes on; in other words, it is rapidly burned, as a taper; and the cost of the metal is one of the objections to the method. In Way's light, however, the mercury is not consumed, but can be used repeatedly, and without apparent deterioration or loss. True, the electricity dashes the metal to some extent against the glass tube which includes the filament of mercury, thus in time coating this tube with patches of the metal that interfere with the transmission of the light; this effect, however, is but slowly produced, and the tubes are readily changed and cleansed.

Two other, and, it would appear, yet more objectionable features of the mercury light, require mention. In the first place, this metal, like most or all others (*see SPECTRUM OBSERVATIONS*), does not when rendered incandescent shine, as do the ignited carbon points, with light of all the colors found in the sunbeam. In fact, it gives out rays of a limited and very small number only of the sorts going to make up the entire spectrum; since, on prismatic analysis, it is said to yield six narrow and definite bands of color only: viz., a brick red, a yellowish orange, two emerald greens near together, a rich blue, and a violet; it is in addition, however, very rich in actinic rays, or those effective in producing the photographic impression. Employed to illuminate dwellings, halls, or natural scenery by night, this light would accordingly show as black or gray all objects having colors other than those of the rays composing it. In the second place, though the mercury used in producing the light is not oxidized, yet the intense heat arising in the filament which is rendered luminous also serves to volatilize the mercury at certain points, so that minute breaks in the thread of the metal occur, and the light is hence a flickering, and not a steady one—a difficulty for which perhaps no remedy can be found.

*Improvement in Holmes' Magneto-Electric Light.*—Prof. F. H. Holmes has a letter in the "Athensum" of Jan. 8, 1868, in which he states that such improvements have lately been made in the lamp employed in his system, that the movement of the carbon points is no longer effected through a delicate and complicated clockwork, but by means of a single wheel and pinion. The lamps in use at Dungeness and at Northfleet, the former 7 months, the latter still longer, have not in all that time been opened, even to be oiled. In the new arrangement, if the light be arbitrarily extinguished, it immediately relights itself, and it is no longer liable to spontaneous extinction. The only



remaining source of interruption is the presence of silica or metallic residua as impurities in the carbons. Thus, when these have wasted to a point at which iron or antimony occurs, there is a slight change of color and momentary flicker, but which are of no practical consequence. In the new arrangement, the attendant of the steam engine can learn in a few hours all that requires to be looked after. The electric light does not, like the oil lights, necessitate an interruption for trimming, a process that with the latter must be performed at least as often as once during each night. The actual expense of the former still remains somewhat the greater; but if its increased intensity and penetrative power be taken into the account, it is really the cheaper; and the qualities just named can be greatly augmented at a slightly increased ratio of expense.

*Serrin's Electric Light Regulator.*—Those specially interested in the subject of electric lights may be referred to an account of the principle of operation of the regulator for such lights devised by M. Serrin, originally appearing in the *Comptes Rendus*, and quoted in the "Journal of the Franklin Institute," Dec. 1862. Briefly, the method is that of holding the carbon points very near to each other by means of springs, but preventing the bringing of the points into positive contact so as possibly to interrupt the light, by so disposing in the apparatus or regulator containing the points an electro-magnet, the armature of which falls as often as the circuit is in such manner completed, that the weight of this armature just overbalances the tension of the lower springs sufficiently to depress the lower carbon to a very slight extent.

*Baker's Apparatus for Electric Lights.*—Mr. A. L. Fleury exhibited at a meeting of the Franklin Institute, April 17, 1862, a magneto-electric machine, and also a mechanism for electric lights, the inventions of Mr. H. N. Baker, and constructed by Messrs. Collier and Co., of Binghampton, N. Y. The mechanism for controlling the relative positions of the carbon points is extremely simple. The carbons are in form of long cones or pencils, and placed vertically, one over the other. A hole in an upper metallic strap or bridge, is of such size that the carbon pencil sinks only to a certain depth in it; while a hole in a lower strap is large enough to allow the lower pencil to rise freely through it. While the current is passing, as is usual, particles are carried off from the positive carbon electrode and deposited on the negative one. Thus, the former wastes, and the latter may be injured by becoming blunt or coated with irregular deposit. To prevent the unlike effect on the two pencils, Mr. Baker resorts to the French system of continually reversing the current; and the waste of both pencils thus becomes similar. Now, the lower pencil being placed as a float (though on what liquid the account does not state), it results that, as the gradual waste goes on, the

upper pencil is simply fed downward continually by its gravity, while the lower one is just as regularly fed upward by its buoyancy. This is the arrangement when a current of large "quantity" and low intensity is employed, the electrodes being in such case satisfactorily ignited although they continue in actual contact. When, however, a current of high intensity is employed, the pencils are allowed only to approach very close, but without touching; and to accomplish this, the hole in the lower strap is also made so small as to admit a certain length only of the pencil. It would appear that the apparatus operates successfully on the scale on which it has been tried, or as an electric lamp; and it is said to be extremely cheap. ("Jour. Fr. Inst.," May, 1862.)

*The Present Desideratum in Electric Lights.*—The magneto-electric light, which is probably the most economical in use, has still the disadvantage of the great waste of power necessarily attending the successive transformations of a given amount of force. In producing this light, the heat developed by the combustion of coal is converted, first, into mechanical power; the mechanical power must then be transformed into electricity, and this finally into a heat which shall result in light. Now, M. Joule has shown that in the first of these transformations, even when effected under favorable circumstances, no more than  $\frac{1}{10}$  part of the heat is actually realized in mechanical power,  $\frac{1}{10}$  of the force developed from the coal being lost. This loss of power, and of useful effect, is strikingly illustrated in the case of the English and the French ice-making machines in the Exhibition of 1862. These machines alike derive their capacity of producing ice from the combustion of coal. But while, in the English machine, the heat of the coal is first converted into the mechanical power of a steam engine, and the product is but two tons of ice per ton of coal consumed, in the French machine this preliminary transformation of the heat through the driving of an engine is dispensed with, and the product is declared to be from 10 to 13 tons of ice for each ton of coal burned in the furnace of the apparatus. These considerations indicate the direction in which the improvement (in economy) of the electric light should be sought. The object aimed at should be that of transforming, as directly as possible, the heat generated by combustion of coal into electric current-force. It is remarked by Dr. Frankland, from whose account of "Illumination" in the "Record of the Great Exhibition, 1862," these thoughts are drawn, that the researches of Dr. Matthiessen on the thermo-electric properties of tellurium promise important results in the direction here indicated.

*Electric Light Signals.*—The electric light, in whatever mode produced, admits of being instantaneously extinguished and as quickly relighted. Hence, it can be made at will to shine or disappear; and a system of signals with

such a light, by timing successive flashes according to a prearranged order of long or short flashes and repetitions, thus becomes practicable. Such a system of flashing lights with the Fresnel lenses is already to some extent in use; and for field operations, as well as in some cases for lighthouses, it may be rendered of great value. For a system of this sort, the name of *Photo-Telegraphy* has been proposed. Another mode of this telegraphing by light, is that of successive flashes of different colors. Mr. Wm. C. Bridges, of Philadelphia, has invented an apparatus for this form of light signals, consisting of a tube and lens, with adjustable mirrors as may be required, and differently colored and also opaque glass slides, to be moved at will in front of the lens. The electric or other light shining continually into the tube, the slides determine by color and intervals of the flashes the character of the signals made. In any mode, the light signals could be, by a customary system, or by systems, secret to all but initiated parties.

*Application of the Electric Light to Mining Purposes.*—MM. Dumas and Benoit have devised a compact and highly portable apparatus, its entire bulk not exceeding that of a small carpet bag, including a battery, a Ruhmkorff coil, and a Geissler's tube, within which the light is generated; the arrangement producing sufficient illumination to enable a miner to work by it, as by a Davy's safety-lamp. This light serves equally well in an atmosphere in which all others fail; while, the light being cold, and its production wholly within a confined tube into which gases have no access, it is perfectly safe against explosion under all circumstances. The arrangement will give light for 12 consecutive hours with no attention save that the workman must occasionally agitate the carbons by means of a rod; and it is instantaneously lighted or extinguished at will, while no injurious emanation arises from it. From results obtained with the use of Becquerel's fluorescence-tubes, it is supposed that the luminous effects are susceptible of further great improvement, both in respect to duration and intensity.

This light, or some other similar in principle, is certain to possess value for other purposes besides mining. Thus, in coal oil factories the best safety lamps are said to fail, since the subtle benzole vapors may take fire through the finest wire gauze. Here, the electric light, within a closed tube, would be entirely safe; and it would also prove peculiarly appropriate where danger from the dashing of water may exist, as in the interior of gunboats and steam rams, and even in diving bells.

*Engraving by Electricity.*—The cylinders of copper brass employed in the printing of woven fabrics and paper-hangings are by a recent invention engraved by means of electricity—the voltaic current being so applied as to communicate the necessary movements to certain portions of the apparatus. The cylinders to be

engraved are first coated on their outer surface with a thin film of varnish, of such nature as to be capable of resisting the continuous action of the strongest acids. The requisite number of copies of the original design are then traced or scratched simultaneously by a series of diamond points, which are arranged on the machine parallel with the axes of several cylinders operated on at the same time. Each diamond point is in correspondence with a small temporary magnet; and the original design having been previously etched on a metal cylinder fitted in with a non-conducting substance, and this cylinder being made to revolve in contact with a tracing point, it results that the current passes, or is interrupted, through the entire series of coils of the electro-magnets, securing the contact of each diamond point with its corresponding cylinder, or the reverse, according as the point rubbing on the first cylinder touches a conducting or a non-conducting portion of its surface: in this way, while the cylinders all revolve at the same rate, the diamond points are made to cut upon all but the first, or are raised from them, and at the same moments. The metallic surface is hence exposed in like parts on all the cylinders operated on; and a bath of nitric or other acid being afterward used to etch or deepen the engraved portion, the operation is completed. By interposing suitable connections, the engravings can be enlarged or diminished to any necessary extent from the same original.

*Electric Despatch.*—The experiment in which a bobbin or coil of wire conducting a current of electricity draws within itself an iron rod of the length of such bobbin, or even sustains the rod, when the arrangement is vertical and the power of the current sufficient, against the force of gravity, is now familiarly known. Availing himself of the converse of this principle, Mr. Henry Cook, of Manchester, England, has constructed and patented an electric propeller for transporting despatches, letters, and other small articles. A line of miniature railway is laid within a tube or pipe extending between the points of communication, and formed of a series of hollow electric coils or electro-magnets. The carriage on which the despatches or other small parcels are transmitted, has mounted upon it a small battery; and the ends of the coils are so adjusted that, by means of the wheels and rails, the battery connection is made successively with each of the coils, just as the wagon is about to enter it. The wagon itself being of sheet iron, it will be attracted toward the middle part of each coil, as the latter is thus made for the time to transmit the current generated by the battery upon it; and the momentum thus acquired by the wagon in entering each of the coils is expected to carry it far enough to make the connection with the next coil, when the impulse and effect are renewed. The suggestion of this device appears to have been made by M. Bonelli.

*Electric Sounding Apparatus.*—This appa-

ratus, the invention of M. Schneider, was successfully employed in soundings on Lake Ladoga in June, 1862. The sounding line was of gutta percha, 2 lines in thickness, 1,800 feet in length, and covered. It contained two wires, one inside the gutta percha, the other within the outer covering. Bruck's sounding apparatus was used, the weight of the leaden plummet being 12 lbs., but with the modification that no part was detached by contact with the bottom. The wires of the line communicated with a battery on board, of 6 elements; and at the moment of the plummet's touching bottom, the current through the wires being established by contact with the earth, an alarm clock attached to the apparatus was sounded. This result was tested by using the electric sounding apparatus at the same time with Bruck's, which operates upon a more usual system; and it was found that even if the bottom were soft and muddy the alarm was still given at the moment of contact. The steamer on board which the trial was made being of iron, M. Schneider experimented to some extent in the way of making the vessel serve as the upper metallic plate, the sounding apparatus serving as the lower, and so employing in the soundings only one of the wires: the result of these experiments also was entirely satisfactory. The apparatus is stated to be cheap and easily managed, and likely to be serviceable for deep-sea soundings.

ELLET, CHARLES, JR., an American engineer, born at Penn's Manor, Buck's Co., Pa., Jan. 1st, 1810, died at Cairo, Ill., June 21, 1862. He was a thorough master of his profession, and his name is identified with several of the most important works in the country. He designed and built the wire suspension bridge across the Schuylkill at Fairmount, Philadelphia, the first in the United States, and subsequently the suspension bridge across the Niagara river below the falls, and one at Wheeling, Va. He constructed the temporary track of the Virginia central railroad across the Blue Ridge, and contributed largely to the improvement of the navigation of the Kanawha river. He aided also in laying out the Baltimore and Ohio railroad, and there are indeed hardly any of the Western or Middle States which do not furnish some lasting evidence of his professional skill. In 1846-7, he was president of the Schuylkill Navigation Company. At the outbreak of the war, in 1861, he was residing at Washington, where he became deeply interested in the conduct of military matters, and devoted much attention to the use of rams in naval warfare. He projected a plan for cutting off the Confederate army at Manassas, which being rejected by Gen. McClellan, he wrote two pamphlets severely censuring his mode of conducting the campaign. The navy department having rejected his plan for the construction of rams for service on the Mississippi, he applied to the secretary of war, and was successful. He was commissioned as colonel of engineers, and con-

verted several powerful steamers into rams which did effective service in the naval battle off Memphis, in which engagement he received the wound whereby he lost his life. He was the author of an "Essay on the Laws of Trade, in reference to the Works of Internal Improvement in the United States;" a paper "On the Physical Geography of the Mississippi Valley, with suggestions as to the Improvement of the Navigation of the Ohio and other Rivers," published in "Transactions of the Smithsonian Institution;" a pamphlet on "Coast and Harbor Defences, or the Substitution of Steam Battering Rams for Ships of War," and several other important and valuable scientific papers.

EXHIBITION, BRITISH INDUSTRIAL. The first International Exhibition was opened by her Majesty, Thursday, May 1, 1851. The exhibition remained open 141 days; its foreign exhibitors were 6,556, and the exhibitors of the United Kingdom and dependencies, 7,882 (exclusive of India), forming a grand total of 18,938. The whole daily admissions by payment amounted to £5,265,429; by season tickets, £773,766; together, £6,089,195. Average visitors on each day, 42,831; greatest number present, on October 7, 109,915; greatest number at one time in the building, October 7, 98,224. Commissioners' receipts from all sources, to Feb. 29, 1852, including subscriptions, £506,100 6s. 11d. Expenditure, £292,794 11s. 3d. Balance, £213,305 15s. 8d. To enable the royal commissioners to apply this surplus and keep faith with the subscribers to the original fund, they were empowered by a supplemental charter to purchase and hold lands in any part of her Majesty's dominions and dispose of them as they thought fit. They first proposed to provide a house for the Trade Museum, a collection of articles valued at £9,000, presented to them by exhibitors in 1851. For this purpose, they purchased the "Gore House estate," at one time owned by Mr. Wilberforce, and subsequently by the Countess of Blessington. The whole estate comprised about 21 acres, added to which were Gray's nursery grounds, Park house, and Grove house, and various market gardens, the grounds of Cromwell House, and other lands belonging to the Earl of Harrington and the Baron de Villars. Additional funds for these purchases were provided by the Government, who entered into a sort of partnership with the commissioners, and purchased, in all, 86 acres, for £280,000, at an average of £3,250 an acre. The object of these purchases of land was to secure a large space to which some of the national exhibitions might be removed, and on which a great art-educational institution might be erected. Early in 1853, the commissioners dissolved partnership with the state; the sums advanced by Government were repaid by the commissioners, subject to a deduction for the ground and buildings of the South Kensington Museum, now become a government institution, as a branch of the department of science and art. The commissioners now be-

came trustees for buying and selling the land, about 12 acres of which they have disposed of very profitably in building leases. Nearly doubling their original capital by the above speculation, they next let the upper part of the great centre square, about 22 acres, to the Horticultural Society. The commissioners have expended about £50,000 in building arcades in the new gardens; and the society have expended an equal amount in terraces, fountains, conservatories, and in laying out the grounds.

The Society of Arts, impressed with the importance of international exhibitions, proposed to repeat the great exhibition of 1851, but the commissioners had not sufficient funds for the undertaking, nor did they think that the scheme would be profitable. But a new commission was organized, and a plan was submitted by Capt. Fowke, R. E., and adopted.

The commissioners informed the Society of Arts that they would grant, rent free, until the 31st of December, 1862, for the purposes of the exhibition of 1862, the use of the whole of the land on the main square of their estate lying on the south side of the Horticultural Society's gardens, estimated at 16 acres, on the understanding that all the buildings to be erected for the exhibition, whether permanent or temporary in their character, should be subject to their approval, and that all the temporary buildings should be removed within six months after the close of the exhibition, if required; the trustees of the exhibition being at liberty, on the other hand, to remove the buildings termed permanent if the exhibition should be attended with pecuniary loss. They further expressed their readiness to grant to the society a lease for 99 years at a moderate ground rent of those permanent buildings if retained, on condition of not less than the sum of £50,000 being expended on them by the trustees, and of their not covering more than one acre of ground; and also on condition of their being used solely for holding exhibitions and for purposes connected with the promotion of arts and manufactures. They said "we would undertake, in the event of the payment to us of the sum of £10,000 out of the profits (if any) of the exhibition of 1862, to reserve for the purposes of another international exhibition in 1872, to be conducted by such body as might be approved by us, the remainder of the land now proposed to be lent by us for the exhibition of 1862 that was not covered by the permanent buildings already referred to, such reservation not interfering in any way with the free use by us of that land in the intervening period." The Society of Arts accepted these terms.

Of the tenders sent in, that furnished by Mr. Kelk and the Brothers Lucas, being the lowest, was accepted. For the rent of the building a sum of £200,000 was absolutely guaranteed; if the receipts exceeded £400,000, the contractors were to be paid £100,000 more for rent; and they were bound, if required, to sell the whole for a further sum of £180,000, thus mak-

ing the whole cost £480,000. The commissioners for 1851 are the legal proprietors of the site, but have agreed to reserve about 16 acres of it for the 1872 exhibition, receiving £10,000 as a sort of ground rent. It is already agreed that the Society of Arts, Adelphi, will be granted the lease of the central portion of the picture gallery, one acre in extent, along the Cromwell road, for 99 years, on payment of a ground rent, and that it be given up unreservedly for the use of the 1872 exhibition.

*Laying out of the Works.*—The laying out of the works was commenced on 9th March, 1861, by three independent agencies—Mr. Marshall on the part of the contractors, while Mr. Wakeford and Sergeant Harkin, R. E., acted for the commissioners. About two weeks were occupied in making the measurements, so that the building may be said to have been actually commenced in the beginning of April, 1861, and to have been practically finished about the beginning of April, 1862. There were 7,000,000 bricks used; of cast iron there are upward of 4,000 tons in the building; and to show what care had been taken with the castings, only four girders proved defective, by breaking in the roof. There are upward of 820 columns, of 25 feet, equal in length to 4 miles; and if the 1,266 girders used were placed end to end, they would reach a distance of 6 miles. The total quantity of wrought iron used was 12,000 tons. Upward of 1,000,000 superficial feet of floor was laid. To cover the roofs 486,386 square feet of felt were used, equal to 11 acres; and to complete the whole of the glazing required 853,000 superficial feet of glass, which weighed 247 tons, and would cover 12½ acres.

*Progress of the Building.*—On the completion of the building the floors and staircases were submitted to the following tests: A large body of men, about 400 in number, were closely packed upon a space 25 feet by 25 feet on one lay of flooring; they were then moved in step, and afterward made to run over the different galleries, and down each staircase; at the same time the deflections of the girders carrying these floors were carefully noted at several places, and in each case the deflections were very nearly the same. The cast iron girders, with 25 feet bearings, deflected only one eighth of an inch at the centre, and the timber-trussed beams of the same bearing placed between these girders deflected half an inch at the centre. In every instance the girders and trusses recovered their original position immediately on the removal of the load.

*The Exhibition Building.*—The internal space is entirely covered in by roofs of various heights, and is divided into nave, transepts, aisles, and open courts; the latter are roofed with glass, as in 1851, but the other parts have windows. The South Front, in Cromwell road, 1,150 feet long and 55 feet high in the brickwork, has two projecting towers at each end, rising 16 feet above the general outline, and a larger tower

in the centre, in which latter is the main entrance to the Picture Galleries; being about as long as the gallery of the Louvre, in Paris. The exterior is chiefly brickwork, relieved with semicircular-headed panels, separated by pilasters, and between the arches are circular niches; in the lower portion of each panel being a window, to admit light and air to the ground floor, and to ventilate the Picture Gallery above. The panels are plastered in cement, and it is proposed to ornament them with English mosaics, dependent on the funds. The East and West Fronts, though differing from the South, are not less imposing. They are, in all respects, similar to each other in their general aspect. Here the huge domes, rising to a height of 260 feet, show to most advantage, and the transept

roof, with its lofty clerestory windows, is in full view. To the observer below, the form of each dome appears nearly that of a semicircle; this effect is obtained by making its height 11 feet more than its semi-diameter, which fully allows for the loss by prospective diminution.

From the crown of each dome rises the pinnacle to the height of 55 feet. Each dome is in the middle of each façade; its centre is the point formed by the intersection of the centre lines of the nave and transept, and the front of the building is advanced from it 108 feet. Under each noble arched recess is the main entrance to the Industrial Courts, the effect of which forms one of the most pleasing exterior parts of the building.

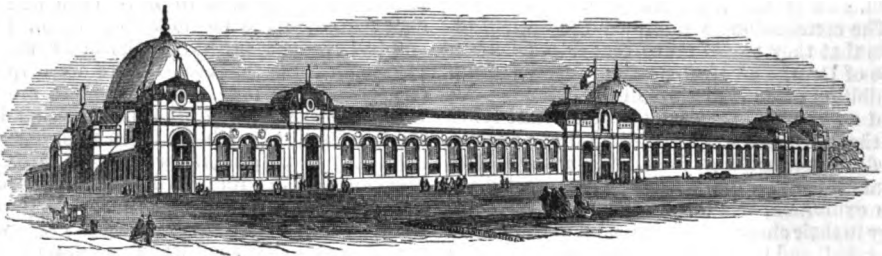

Each of the porches contains a deep semicircular arched recess, 68 feet span and 80 feet high, in the tympan of which is the great rose-window, visible from end to end within. The window is one closing the vista as the spectator looks from a standing point beneath the other.

At the extreme north and south are two auxiliary picture galleries, each 247 feet long. The main and auxiliary picture galleries afford available wall space covered by pictures, equal to 7,600 square yards, or about one and a half acres.

The two duodecagonal domes are of glass, with an outer and inner gallery, 160 feet in diameter, and 250 feet high.\* The dome of the Pantheon is 142 feet in diameter and 70 feet high; the dome in the Baths of Caracalla was 111 feet; Brunelleschi's, at Florence, is 139 feet in diameter and 133 feet high; the dome of St. Peter's is 158 feet in diameter, and 263 feet high from the external plinth; the dome of St. Paul's Cathedral is 112 feet in diameter, and 215 feet high.

The *Annexes* are engineering works of great merit.

The western Annexe is 975 feet long, and 200 feet and 150 feet wide. The east side is enclosed by the back wall of the west arcade of the Gardens, and the west side, which adjoins the road, has a plain lath-and-plaster front. It is covered by a ridge-and-valley roof, sup-

ported on light wooden ribs, similar in construction to those of the nave; that is, they are formed of planks nailed together. The circular portion springs at ten feet above the ground line. Its elevation is nearly half of a regular polygon, described about a semicircle whose diameter is 50 feet; it consists of three planks nailed together. The principal rafters, which are composed of two  $\frac{1}{4}$  inch planks, rise from a point 28 feet above the ground, and meet above the curved ribs, so as to make the ridge five feet above the crown of the arch. The upright, which has its foot mortised into a sleeper resting on piles, is formed of  $1\frac{1}{2}$  inch centre plank, with a  $\frac{1}{4}$  inch plank on each side, having a strengthening piece four inches by three inches spiked to it on either side to prevent its bending. The principal rafter and upright are connected with the curved rib by radial pieces of  $1\frac{1}{2}$  inch plank, which are brought rather below the inner line of the curve, and finished off, for the sake of ornament, by a spear head. The roof frames are therefore merely planks nailed together, and so disposed that the weight comes on their edge. One half of the roof is covered with boards and felt; and the other half has a glazed skylight, with louvres for ventilation throughout the whole length.

The western Annexe, is devoted to the exhibition of machinery in motion, for which purpose steam pipes, water pipes, and shafting are led through it. Its superficial extent is about four and a half acres. The entrance is through the north end of the west transept, from which

\* The dome of the old Halle au Blé, at Paris, of timber, was 300 feet diameter; and after its destruction by fire was replaced by the wrought iron and zinc dome, still in existence, of the same dimensions.

point the ribs of the roof are seen from end to end in fine perspective.

The eastern Annexe is exactly similar to the western in its construction; but it is 200 feet shorter.

*The Interior.* Entering east or west, the ascent is by two steps until the level of the dais under each dome is reached. From either point the interior of the whole building may be seen in one view, at 6 feet above the rest of the floor. Thence three flights of steps, 80 feet wide, lead into the nave and transept on either side.

The supports on either side of the nave (800 feet long and 100 feet high) consist of square and round cast iron columns, coupled together; the former carry the gallery floor, and the latter, advancing into the nave, receive the principals of the roof. From the capitals of the columns spring the roof frames, which consist of three thicknesses of plank, from 18 inches to 2 feet 6 inches deep, firmly nailed and bolted together, and so arranged that their ends break joint. The centre plank is 4 inches thick, and each of the outer ones is 8 inches; the lower edges are tangents to an imaginary semicircle, round which they form half of a nearly regular polygon. From the springing rise the posts of the clerestory windows, 25 feet high. The principal rafters of the roof frames rise from the top of these posts, and are carried up, after passing a tangent, to the back of the arch, to meet at the ridge in a point 25 feet above the top of the clerestory. The angles over the haunches and crown of the arch are firmly braced together, so as to reduce the thrust as much as possible.

The rib is repeated thirty times in the length of the nave, and from its graceful curve and lightness it produces a fine effect. Between every roof principal is a clerestory light 25 feet high, consisting of three arches springing from intermediate mullions. The roof is covered with felt and zinc on 1½-inch planks. The transepts run from each end of the nave, at right angles to it, and extend north and south 650 feet; they are the same width and height as the nave, and the ribs of its roof are of the same construction.

*Construction.*—The principals were placed in the nave roof. This was done by a huge moveable scaffold. One half of a rib was first hoisted to its place; when in position, the other half was raised; and as soon as both were fixed true, they were joined together by completing the arch and bracing over its crown.

The hoisting was all done by a hoist, connected with a portable steam engine.

The galleries form an abutment to the nave and transept roof. As the roof thrusting outward tends to throw the columns out of the perpendicular, this is counteracted by strong iron braces anchored to the foundation of the inner column, and carried up to the top of the opposite outer column. Another bracing, anchored to the footing of the outer column, is

carried up to the top of the inner column, to secure it from being acted on by the force of the wind. This vertical cross-bracing is repeated at every hundred feet, or every fourth bay, and by introducing horizontal diagonal bracing under the roof flats, they are turned as it were into a deep horizontal girder, supported at two ends by the columns vertically braced as just described. This horizontal girder therefore takes the thrust of the three intervening ribs.

The whole structure may be separated into three classes of work—that which is meant to be permanent, viz., the front façade and the narrow strips of brick buildings at both wings running north and south; that which is *quasi* permanent, viz., the naves, transepts, domes, and covered courts and galleries; and that which is absolutely ephemeral, in the Annexes, and the refreshment rooms over the arcades at the south end of the Horticultural Garden. Standing at the centre of the front in Cromwell road, we have the front building of 1150 feet 9 inches extreme length stretching right and left, with a general width of 50 feet, and two stories in height. At the centre are the grand entrance hall, vestibule, and within these, to the right and left, the grand staircases leading to the higher floor; returning southward we enter a hall of 150 feet in length, for sculpture chiefly, and as a vestibule to the great ranges of picture galleries to the east and west, and extending on into the wing tower buildings to a total length of about 500 feet each way.

The appropriation of the several portions of the building is briefly thus:—the nave, transepts, galleries, and courts for the display of general industrial productions; the brick building on the north, inclosing the narrower courts, for refreshments; the grand picture gallery extends along the south, and has auxiliary wings in front of the east and west transepts extending their whole length; these picture galleries requiring to be lighted from the top, are placed above the entrances, which on the south side stretch to either hand for the display of carriages, &c.

*Decoration of the Building.* This cannot be better described than by Mr. Orace, who, in April, 1862, read before the Society of Arts a paper in which he informs us that it was the 28d January last when he received his authority to proceed with the decoration, and it was to be all completed by March; that is to say—some twenty acres decoratively painted in about eight weeks.

“After careful consideration I decided that the general tone of the roof must be light, and that the best color would be a warm pale gray; that the arched principals must be made to stand out clear from the roof; that they must look well in a perspective of 800 feet; and that they must not look heavy or confused as they approached each other in the distance. The form of these is polygonal, and in three thick-

nesses, the centres of the outer planks covering the joints of the inner ones.

"I therefore decided on following the form of the construction, and adopted panellings of blue and red alternately, relieved by colored lines, intersected at the joints by circles of black on which are gold stars, and from these spring ornaments in vellum color with green in the filling, to make the construction evident, and I therefore colored the two outer edges in chequers of black and vellum color, and the centre edge full red. As to the bracings above the polygonal arches I colored them the warm-wood color, with red or blue colored lines on the face, and the under thicknesses red.

"I decided on warm gray for the roof of the nave to give space and lightness; and on its surface I introduced an upright scroll ornament in red, with gold, star-like rosettes, sparingly introduced. My object in this ornament was to raise the apparent pitch of the roof, and to relieve and warm the effect of the gray. The horizontal purlins, on the contrary, I kept purposely light, so as not to depress the rise of the roof, or interfere with or confuse the effect of the principals. The ridge piece of the roof, in itself comparatively small, I marked as strongly as possible, as the apex, in black and vellum white, *en chevronné*; on each side I colored a margin of maroon red, and a little below that a bordering of very warm green, shaped to accord with the top scrolls of the red vertical ornament, the green being relieved with rosettes of gold color. At the base of the slope of roof this green is again introduced in much the same way, and the band of maroon also. Below this are the clerestory windows.

"The next important features in the nave are the iron columns, supporting the principals as well as the galleries, painted pale bronze color, relieved with gold color vertical lines. The capitals are gilt; the grounds of the ornaments being picked in rich red or blue alternately; the centre blocks of the columns are also colored red, with bands of blue, or, *vice versa*, the mouldings being gilt, and the same style of color is continued to the bases. The top plate above the columns is painted bronze color, relieved with light gold color ornament on the upper part, and a Vitruvian scroll in gold color, with a maroon red base on the lower part.

"The gallery railings are light bronze color, the rose, shamrock, and thistle ornaments being partly gilt, and the whole backed with deep red cloth. The plate under the gallery is painted oak color, relieved with deep brown interlaced ornaments.

"I have kept the part below the line of arches purposely quiet in color, in order that the brilliancy and richness of the various articles exhibited may not be interfered with. The roof, on the contrary, is rather vivid in color, to carry up, as it were, in some degree, the gayety of the scene below; and this will be still further sustained by a series of banners of

the various countries whose products are assembled in this International Exhibition.

"In the roof of the Upper church of Assisi, in the chapel of St. Corporale, of Orvieto, in the choir of Santa Croce at Florence, and in the Palazzo Spinola, examples are to be found of counterchanging of coloring, and in the roof of the cathedral of Lucca, of the chevronne of black and gold.

"Those decorations, so beautiful, so interesting, rich, glowing in color, full of fancy and taste in the ornament, the masses well arranged, show the most perfect harmony everywhere, and are dignified by often acting as the framework of the highest gems of art.

"My principal difficulty in carrying out the decoration of the domes was, that I could see nothing of them. The scaffold formed a series of solid stages or floors, through which it was impossible to view anything; and I confess I never could mount the ladders above one hundred feet; but even there the scaffolding was so thick that I could see nothing of the top, and very little of the cornice, fascia, and walls.

"At last, Mr. Ashton, the engineer, contrived to get for me an open square box, into which I got, and I was drawn up by means of his beautiful little engine very pleasantly to the top; yet when I got there the ceiling almost touched my head, so that I had no opportunity of judging beforehand of the effect of distance and light upon my coloring, and I knew well that they were very formidable elements for consideration. The knowledge that the scaffold would be taken down before I could possibly judge of the effect, and that when once down, I could never hope to touch my decoration again, caused me many an anxious thought.

"In coloring the top of the domes, the main ribs are painted bright red, with spaced black and white at the edges, and a fine gold line up the centre spreads at intervals of about four feet into lozenges and circles containing gilt stars on a blue ground; where the main rings reach the ring plate I carry round the red, marking the points of intersection with black and white; thence the eight main ribs are painted deep blue, relieved with red, gold, and black, until they meet in the centre pipe or pendant, which is gilt bordered with red. The shaped covering, or umbrella, as I am accustomed to call it, is painted light blue; gold color and gilt rays diverging from the centre and streaming a considerable way down the blue, the shaped outline of which is bordered with red and gold ornament.

"In decorating the walls of the domes, the solid parts between the arches, and the springing of the roof, it was necessary to consider the probable effect of the great mass of light above. On the one hand it was desirable to sustain it with sufficient strength of color, on the other it would be dangerous to make it too heavy.

"The moulding of the cornice and fascia are

painted vellum color, very slightly relieved by gilding; the trusses are gold color; the fascia between them is red, with a vellum patera; the soffit is green. The broad fascia below is painted blue, and on it is inscribed in gold letters, three feet high, the exordium of David in the 29th chapter of the first Book of Chronicles, 'Thine, O Lord, is the greatness, and the glory, and the victory, and the majesty: for all that is in the heaven and the earth is thine;' and, 'O Lord, both riches and honor come of thee, and thou reignest over all; and in thine hand is power and might, and in thine hand it is to make great.'

"The large iron columns, which rise nearly one hundred feet high, are painted dark maroon color, their capitals being richly gilt. The panelling between the arches and the frieze is painted in shades of red, relieved by colored lines; in the four broad compartments are inscribed, on dark green panels, Europe, Asia, Africa, and America; below, on a circle, are the initials of those so beloved by us all, Victoria and Albert. On the eight spandrils to the four main arches, are medallions, eight feet diameter, by Mr. Burchett, of the Kensington school of art, emblematic of manufactures, commerce, and the various arts and sciences which lend their aid. Around the red paneling is a broad margin of sage green, on which are stencilled pateras. The moulding of the arches is painted vellum color, the top fillet being gilt; and the face of them ornamented with Vitruvian scroll in dark color.

"The walls at the gable end of the nave and transept are treated so as to recall the arched form of the principals. Under these a semicircular panel is formed of warm brown color, bordered by a broad blue margin, on which are gold stars. Inside the panels are written the following sentences:

"On the east end of nave—

"The wise and their works are in the hands of God."  
—ECCLIASTAS, ix, 1.

"On the east end of transept—

"Alternately the Nations learn and teach."—*Cowper*.

"On the southeast end of transept—

"Each climate needs what other climes produce."—*Cowper*.

"On the west end of the building the sentences are in Latin, being the part occupied by foreign exhibitors. At the end of nave is written:

"Gloria in excelsis Deo, et in terra pax."

"At the northwest end of the transept—

"Domini est terra, et plenitudo ejus."

"At the southwest end of transept—

"Deus in terram respexit, et implevit illam bonis suis."

"Inside these semicircular panels are a series of radiating panels, painted maroon, and bearing the names of the various sciences and arts which have affinity with the objects exhibited."

*The Exhibition Opened.* By a wonderful effort of labor, the executive staff of the International Exhibition were enabled to keep their

promise to the public, and open the grand display, with all befitting ceremony, and even with more than hoped-for success, on Monday, May 1, 1862. The day, indeed, had one dark shadow. Of the hundreds of thousands who lined the streets and thronged the building, few forgot the Prince by whom the great work of the day was encouraged and helped on. The absence of the Queen, and the cause of that absence, marred the state pageant, and produced a partial gloom which an impressive and imposing ceremonial could not wholly dispel.

The Duke of Cambridge represented her Majesty and received the address of the Commissioners, to which he made a reply.

Earl Granville then, on the part of the Commissioners of the Exhibition, presented to his Royal Highness the "key," technically so called, of the Exhibition. This is, in fact, a master key (manufactured by Messrs. Chubb), and which opens the entire number of the different suites of locks on all the doors of the buildings. It is beautifully wrought entirely by hand out of a solid piece of steel, and was inclosed in a crimson velvet bag.

This concluded that part of the ceremonial which took place under the western dome, and before the throne; and the procession, being re-formed, proceeded in the same order along the north side of the nave to a large platform under the eastern dome, immediately in front of the gigantic orchestra, consisting of two thousand voices and four hundred instrumentalists. It commenced with a grand overture by Meyerbeer, comprising a triumphal march, a sacred march, and a quick march, and an embodiment of "Rule Britannia;" then Dr. Sterndale Bennett's chorale, which had been composed for the words of the ode written by the Poet Laureate Tennyson, as follows:

Uplift a thousand voices full and sweet,  
In this wide hall with Earth's invention stored,  
And praise th' invisible universal Lord,  
Who lets once more in peace the nations meet,  
Where science, art, and labor have outpour'd  
Their myriad horns of plenty at our feet.

O silent father of our Kings to be,  
Mourn'd in this golden hour of jubilee,  
For this, for all, we weep our thanks to thee!

The world-compelling plan was thine,  
And lo! the long laborious miles  
Of Palace; lo! the giant aisles,  
Rich in model and design;  
Harvest-tool and husbandry,  
Loom and wheel and engine,  
Secrets of the sullen mine,  
Steel and gold, corn and wine,  
Fabric rough, or fairy fine,  
Sunny tokens of the Line,  
Polar marvels, and a feast  
Of Wonder, out of West and East,  
And shapes and hues of Art divine!  
All of beauty, or of use,  
That our planet can produce,  
Brought from under every star,  
Blown from over every main,  
And mixed, as life is mixed with pain,  
The works of peace with works of war;  
War himself must make alliance,  
With rough labor and fine science,  
Else he would but strike in vain.—  
Ah, the goal is far away,  
How far is it? who can say,  
Let us have our dream to-day.—



Oh ye, the wise who think, the wise who reign,  
 From growing commerce loose her latest chain,  
 And let the fair white-winged peacemaker fly  
 To happy havens under all the sky,  
 And mix the seasons and the golden hours,  
 Till each man find his own in all men's good,  
 And all men work in noble brotherhood,  
 Breaking their mailed fleets and armed towers,  
 And ruling by obeying Nature's powers,  
 And gathering all the fruits of peace and crown'd with  
 all her flowers.

Auber's "Grand March" followed.

After the conclusion of the special music, the bishop of London, with much fervency of manner, read an impressive prayer.

Handel's mighty choral hymns—the "Hallelujah" and "Amen," from the *Messiah*—followed.

After the "Amen" the National Anthem was again sung, and with this the music to the religious part of the ceremony came to a conclusion.

The Duke of Cambridge then rose, and in a loud voice said: "By command of the Queen, I now declare the Exhibition open."

The trumpets of the Life Guards saluted the announcement with a prolonged *fanfare*, and the crowd echoed it back with a cheer, which was taken up and speedily spread from one end of the building to the other. This ended the official ceremonial.

**OBJECTS AND ARTICLES EXHIBITED.**—*Mining, Quarrying, and Metallurgy.*—A case devoted to aluminium, showed the progress already made in the application of that valuable metal and of its alloys. The metal is obtained from the double chloride of aluminium and sodium by fusion with sodium. Amongst its advantages, besides non-liability to tarnishing, is the lightness. By its use, a sextant which in brass would weigh 8 lb. may be made to weigh 1 lb. 9 oz. It costs 40s. per lb. troy. The alloy of the metal with copper, called aluminium-bronze, contains five per cent. of aluminium, and costs 4s. 6d. per lb. avoirdupois. This alloy resembles gold in appearance; whilst it is stronger than iron. Keys are made of aluminium alloyed with two per cent. of nickel to increase hardness.

Of copper, in the Exhibition, there were specimens of ores from nearly every part of the world. The Connoree Mining Company, Ireland, exhibited calamine, the ore of zinc, from a new locality. Ores of zinc were also shown in the Belgian, Zollverein, Austrian, Swedish, Spanish, Portuguese, and United States departments. In the Belgian department, Muller and Co. exhibited spelter produced in a blast furnace; a process long attempted in vain.

Cadmium, generally found in zinc ores, was shown in the Polish and Zollverein departments, in foil and cylindrical sticks. Cadmium, combined with sulphur, forms a fine yellow, opaque, durable pigment, much prized by artists. It is much in request for Wood's newly-discovered fusible alloy, which melts at a temperature far below boiling water.

Of tin, the Exhibition presented nothing remarkable or novel.

Lead (galena) was shown in nearly all the departments, the Italian and Portuguese being especially interesting. There was, however, nothing in the Exhibition to indicate that progress has been made toward the solution of the great problem of condensing lead fume. In one year a large smelting establishment in the north of England obtained 800 tons of lead from the dust accumulated in their long fues.

Arsenic was sufficiently represented. Nickel is now much used for electro-plated articles, and the nickel manufacture was first brought to its present perfection in Birmingham. Nickel is now employed in the coinage of Switzerland, Belgium, and the United States. Ores of nickel were exhibited by several manufacturers of German silver.

Cobalt, valuable for its forming blue color, was found in the Zollverein department, and the United States. Oxide of Cobalt is now largely employed by the potter and glass-maker in Birmingham: the fine "flowing blue" on our china was the result of the first application of this oxide.

Antimony was well represented in the Exhibition. Its chief ore is sulphide, which has during many years been regularly and largely imported into this country from Borneo.

The Exhibition contained several interesting and important illustrations of mercury or quick-silver. It chiefly occurs in nature in combination with sulphur, constituting the well-known mineral, native cinnabar. Magnificent specimens of this mineral from the Almaden mines were found in the Spanish department in the nave.

All galena contains silver, though not always in sufficient proportion to allow of its profitable extraction. It is generally admitted that only lead containing more than two ounces of silver to the ton can be subjected to Patinon's well-known process of desilverization with advantage. By this simple and important invention an enormous amount of silver has been saved to the world.

Rich sulphide of silver has recently been discovered in Cornwall, but hitherto it has not been possible to procure even a specimen, as the adventurers are desirous of attracting the notice of the crown as little as possible; for a mine of which the ore is sulphide of silver would undoubtedly be a mine royal, and belong to the Crown.

Gold was displayed in marvellous profusion in various departments. All native gold contains silver, which varies much in proportion, and tends to render the gold pale in color. All lead contains gold in addition to silver, but in quantity generally so minute as to be valueless. But there it is, and it may invariably be extracted from lead, so as to be distinctly visible.

A series illustrative of the extraction of gold by chlorine water from the residua obtained at the arsenic works at Reichenstein, in Silesia, was exhibited in the Zollverein department.

Clay and terra-cotta manufactures were rep-

resented chiefly by fire bricks and retorts for various purposes.

Building stones were exhibited in great variety.

Slate was shown in plain slabs, roofing forms, and decorated, that is, enamelled. The Llangollen Slab and Slate Company exhibited slabs of great size and good quality, 16 feet and 20 feet in length. The Rhiwbrydir Slate Company showed that a block (18 inches by 10 inches) which is an inch and a half thick, may be split and dressed into 89 slates; and that out of a block (20 inches by 10 inches) half an inch thick, 8 slates can be sawn, the waste in such case being hardly perceptible. A model of a slate-dressing machine, consisting of knife-edges placed obliquely on a revolving drum, so as to work like the down-cut of a carpenter's saw, was exhibited by one of the Port-Madoc contributors, Mr. J. W. Greaves; and the company there, above named, seem to have a machine that will dress 12,000 to 15,000 slates *per diem*, accurately and completely.

M. Alibert exhibited in the Russian portion of the nave blocks of graphite or plumbago, from an extensive bed recently discovered in Siberia. It takes so high a polish as to be mistaken for steel. In travelling through Eastern Siberia M. Alibert found some traces of this mineral in a remarkably pure state, and knowing its value and importance, he set himself to work to search for the vein, which he felt satisfied must be in the neighborhood. For fifteen years, at considerable expense, he persevered, and was at last rewarded by arriving at a bed of graphite.

The French geological maps of France were numerous and important. Among the more remarkable was an atlas of twelve sheets, forming a map of the ancient principality of Dombes in the department of the Ain, a curious district of about 100,000 hectares, of which area more than one sixth has been converted into fish-ponds, which are in number about 1,600, and are emptied every two years to obtain the fish, and to be planted for cereals, and afterward again filled with water and stocked with young fish. The insufficiency of the population and other causes led to the method of cultivation. The method has, however, been most injurious to health in the district. An instalment was shown of a great work, that of ascertaining the levels of principal spots over the whole of France continental, suggested in 1857, by Mr. Bourdaloue, who had already completed a similar work for the department of the Cher. The object is to render more easy and certain the operations having relations to new routes, watercourses, drainage, and irrigation. Great detail and exactness therefore were required, which would involve much expense. The first part of the undertaking, comprising the fixing the principal points, was commenced at the end of September, 1857, and will be finished before the end of the present year.

#### CHEMICAL SUBSTANCES AND PHARMACEUTICAL

**PROCESSES.**—The display of chemicals in the Exhibition was the finest yet collected together. Not only were the exhibitors more numerous than in 1851, but there were more first-class names on the list, hardly one manufacturer of eminence being absent. In the leading branches of chemical manufactures the show was wonderfully good. The specimens of alkalies, alum, and the coal tar dyes generally, constituted the great bulk of the Exhibition.

One of the great features in the class was the splendid collection of drugs formed by the Pharmaceutical Society, which filled one of the finest cases in the whole building.

A new product, for the first time, was exhibited—the silicate of alumina—a beautiful crystalline substance resembling glass. It is formed by mixing two alkaline solutions of silica and alumina; from the great affinity of the alumina for the silica a union is formed between them of a most permanent character. The bases in the mixed solutions, however, showing a most energetic action in strong solutions, when diluted with water have that action so retarded that they remain in the form of a liquid for some hours, admitting of many useful applications, such as the preserving of stone by induration, and the manufacture of artificial stones, which processes were exemplified.

White wine vinegar is obtained, in the form of acetic acid, from the smaller branches of the oak and other hard woods, and it is now also obtained from—sawdust. This dust now finds itself entering the mouth of a long retort through a hopper, is coaxed forward by an endless screw occupying the whole diameter of the retort, and brought under a heat that implies destructive distillation, thus parting with its volatile products.

Cundy, of Battersea, exhibited the permanganate of potash, a most powerful and innocuous deodorizer and disinfectant: its oxidizing powers are beautifully shown by treating pure and impure water; with a small quantity of the fluid, each water may be perfectly pellucid or clear; but if organic matter be in solution, it will instantaneously be oxidized and precipitated as a powder to the bottom, leaving the water colorless; but if nothing of the kind exists in the water, it remains tinged with the pink color of the fluid.

Paraffine was well illustrated. In the Great Exhibition of 1851 Mr. James Young exhibited specimens of paraffine and paraffine oil, and one candle, the product of the distillation of coal. Mr. Young has been fortunate enough to make what Liebig some years ago said would be one of the greatest discoveries of the age—viz., the condensation of coal gas into a white, hard, dry, solid, colorless, odorless substance, portable, and capable of being placed upon a candlestick or burnt on a lamp.

Among the substances shown was a new material, called "Parksine," from the name of its discoverer—the product of a mixture of

chloroform and castor oil, which produces a substance as hard as horn, but as flexible as leather—capable of being cast or stamped, painted, dyed, or carved, and which, above all, can be produced, in any quantity, at a lower price than gutta percha.

Here may be mentioned the principal improvements during the past ten years in France, in chemicals and pharmaceutical products and perfumery, including colors. Such improvements are, the use of pyrites in place of sulphur, which has caused reduction in the price of sulphuric acid; the extension of the indigenous production of potash by the calcination of the residues of the distillation of beet-root juice; and the preparation of *potasse du suint*; the development, in the process of extraction from the waters of saltmarshes, of the sulphate of soda and the salts of manganese which are contained in them; the improvements in the production of ammonia, and its salts, from the condensed fluid collected during distillation of coal; the development of the industries of the distillation of coal tar, and the preparation of Benzine and certain acids; the application, more and more frequent, of the silicates of soda and potash, to the conservation of monuments and sculpture; the new industry of the salts of alumina with a soda base, and of pure alumina; the experiments for the industrial production of the prussiates and ammoniacal salts by ammonia and carbonate of barytes; increase of the production of pyroligneous acid and its compounds; development given to the fabrication of the vegetable alkaloids; extension in the manufacture of white lead, and artificial ultramarine; introduction of the yellow, red, violet, and blue coloring matters, resulting from the transformations of aniline; and the use of sulphuret of carbon for the extraction of fatty substances and perfumes.

*Coal Tar and Lichen Dyes.*—Strange and curious were the illustrations exhibited of the coal tar dyes, and their wonderful effects already mentioned. Coal tar is the basis of all the new colors we have lately got, such as mauve and magenta, and this field of chemical research seems boundless in extent. Thus, coal tar is gradually refined upon and improved till the dirty mass becomes a liquid of glowing tints, the dye of which is shown by exquisite silks, feathers, and moiré antiques, tinted of the now so fashionable colors. The way in which the color is produced may be told in a few words. Coal tar, when distilled, yields a colorless fluid called benzole, much used for removing grease stains from silk or cloth. This when mixed with nitric acid forms nitro-benzole, which when again distilled with acetic acid and iron filings forms those exquisite green crystallizations called aniline. This when distilled again with different salts, produces dyes of different colors, such as mauve and magenta; and thus the coal tar, which was of such little value that it almost puzzled gas-factories to get rid of it, has become the basis of a most impor-

tant manufacture. Aniline was but a few years ago so rare as to be known among chemists almost only by name. Now it is an article of commerce. A few grains of it suffice to dye many yards of fabric, and it is well that it has this power, for two gallons of coal tar only yield ten grains of aniline. One circular block of aniline about twenty inches high by nine inches wide was shown, which was the whole product of no less than 2,000 tons of coal. This specimen is sufficient to dye 300 miles of silk fabric. Where two quantities are given it is easy to find a third. With the *data* which we have stated, therefore, as to two gallons of coal tar yielding ten grains of aniline, and the product of 2,000 tons of coal being capable of dyeing 300 miles of silk, any lady of a calculating turn of mind can reckon to a bushel the precise amount of coal consumed to color the mauve dress in which she is attired. A grain of the aniline dissolved in water tinges it at once of that reddish violet, the delicate color of which can only be compared to the brightness of a flash of electricity.

Near these were shown the products of the lichen dyes, the beautiful blues and purples which are made from the common mosses and lichens. This was accidentally discovered, for the mosses have to undergo a particularly offensive course of treatment before they yield their tints. Where the specimens of the mosses used were shown, the fabrics dyed with their colors were displayed above them, so that, except in witnessing the actual process, the whole *modus operandi* was told to the visitor clearly enough. Near these were shown some specimens of indigo and indigo dyes; while round about were displayed all the wonderful forms of crystallization, from masses of alum as big as grottos, down to groups of crystals of soda, of salt, and saltpetre. Some of the single block crystals of alum weighed from five to seven tons.

*Substances used for Food.*—The collection of these articles was numerous and interesting. Sugar, long considered a neutral substance without congeners, has, in consequence of chemical research, become the parent of a numerous and increasing family. Fourteen specimens were exhibited by Derby and Gosden, including not only beautiful forms of cane and grape sugar, but also sugars derived from acorns, &c., muscular fibre, beets, and other animal and vegetable substances.

Mr. Hallett exhibited his wonderful examples of "pedigree wheat." He has applied to the growth of wheat the rules which every stock-breeder in the country knows—namely, that from the largest and best animals the largest and best progeny may be expected, and that, therefore, the agriculturist should proceed to develop the productive powers of wheat as if it were altogether a new species of cereal which he was trying to bring to perfection for the first time. Mr. Hallett, in 1857, planted only from ears  $4\frac{1}{2}$  inches long, containing 47 grains. In 1858 his finest ear was  $6\frac{1}{2}$  inches long, con-

taining 79 grains, and there were 10 ears from the finest plant. In 1860 the ears were imperfect, from the wet season, but they appear only to have reserved and husbanded their productiveness for a more auspicious occasion, as in 1861 the finest ear was no less than 8½ inches long, containing 123 grains, and the number of ears in the finest single plant had risen from the starting number of 10 in 1857 to 52 in 1861. The various ears and their dates of sowing were shown.

Mr. Spence, of Manchester, has devised a process whereby he is able to produce sixty-five tons of ammonia alum from fifty tons of coal shale.

Valuable improvements have been made in the preservation of meat and other articles of diet. Jones and Trevithick exhibited a raw leg of mutton and other meats, which appeared perfectly fresh after a long interval of time. In their process the meat is introduced into a tin vessel, the air is exhausted, and a small quantity of sulphurous acid gas is introduced, which is quickly absorbed by the juice of the meat. Nitrogen (or azote), which is incapable of exerting any putrefactive action on it, is then permitted to enter the vacuum, and the can is sealed. Should this process prove successful a great step will be gained. Mr. McCall exhibited meats preserved in the old method—viz., expulsion of the air by boiling. The speciality of his process consists in a plan for the absorption of any oxygen remaining in the case. In the top of his can is a small capsule in which he places a button of fused hypo-sulphite of soda; this, when exposed, as the can is soldered, is supposed to take up the oxygen left in the vessel. The opened case of beef appeared quite fresh.

The increasing demand for agricultural produce necessitates the application of manure to restore to the ground the elements taken from it. Mr. Whitworth, of Bermondsey, has endeavored to make still further use of fish for the purpose, and exhibited specimens of his concentrated fish manure for cereal crops.

*Indian Products.*—Three hundred samples of tea were shown, and more than one hundred of cotton, with some tobacco; and of starchy products were two or three novelties. The elastic gums contained some novelties obtained from the Mudar plant (*Calotropis gigantea*), and also from the milk-hedge (*Euphorbia antiquorum*), and other species of Euphorbia (*E. tortilis*). Of woods there were from twelve to fifteen hundred specimens. Amongst the curiosities of food, we had, in addition to the usual contribution of sharks' fins, birds' nests, trepang, agaragar, &c., some potted fish gnapie, dried mushrooms from China, dried fungi, and other delicacies.

The most suggestive, but least attractive, portion of the Indian display was at its entrance, where one of the great tests of a country's value was shown by a collection of its raw materials and natural products. Beyond these came its

manufactures—native locks that would puzzle Hobbs to pick; cutlery from Salem that should astonish Sheffield. Beyond these were weapons damascened in gold, and then gold and silver work, and enamelled jewelry. Among a curious collection of articles from Darjeeling and Thibet are the prayer cylinders—a common brass cylinder, filled with printed prayers, which the natives spin and turn round, and every revolution counts as so many prayers said. In some parts near Thibet, where the strictest Buddhism prevails, these prayer cylinders are made of great size, and turned by water power, so as to do the praying of the whole village in which it works without a moment's cessation. This easy method of invocation is so extensively practised by all the natives, that printing in Thibet is confined almost exclusively to the production of the innumerable prayers that are required by the people. The printing blocks used for this purpose in Thibet and Darjeeling were shown in one of the cases. They are cut in coarse wooden blocks, and in workmanship are apparently on a par with what Caxton's first failures must have been.

*MACHINERY.*—Of locomotive engines there was a magnificent rank, eight or nine at least, with tenders attached, in complete working order. Mr. Ramsbottom exhibited an admirable invention for watering tenders of trains while at full speed. This was originally invented to facilitate still further the rapid progress of the Irish express train between Holyhead and London. The plan simply consists of a sunk trough filled with water, laid at certain stations between the rails, and into which, as the engine approaches, a slanting, trumpet-shaped shoot is lowered, up which the velocity of the engine forces the water with such power as to fill the tender tanks in a single minute. The Great Northern (of France) Railway Company sent a monster locomotive engine, which has its boilers, cylinders, water tank, and coal bunk built up one above another to such a height that the wonder is how it can pass under an ordinary bridge. Its chimney, instead of standing straight upright, as is the manner with ordinary locomotives, has to be curled over its back like an elephant's trunk. It is intended for heavy traffic only. Among other improvements it is fitted with a superheating apparatus.

*Traction Engines.*—Bray's traction engine, considering its great capabilities, is a remarkably compact and simple piece of locomotive machinery. A specimen exhibited was built for Woolwich Dockyard. It combines many improvements upon the earlier contrivances for the purpose of transporting heavy weights by steam power; but the feathering principle of the wheels, as originally introduced by Mr. Bray, is retained. This principle consists in the circumference of the wheel having a number of small apertures through it. These apertures are the media which allow of the protrusion and withdrawal, by means of an eccentric,

of a series of blades, or teeth. The teeth may be adjusted to the nature of the soil, or paving, over which the engine has for the time to travel: that is, they may be lengthened or shortened, so to speak, at the will of the attendant. In many cases the teeth are not required to be protruded at all, the friction of the periphery of the wheel being sufficient for the purpose of traction. In such cases the blades may be thrown out at the top, or on that part of the wheel not coming in contact with the road. On the contrary, in the event of the ground being soft and slippery, or of the engine having to ascend a steep incline, the powerful auxiliary aid of the teeth can be brought into action, and the requisite amount of biting insured. A powerful engine of this kind was employed in the conveyance of ordinary locomotive engines, heavy castings, and machinery of various kinds, from the docks, railway stations and manufactories to their destinations at South Kensington: it was thus a potent contributor to the magnificent display of machinery in the western Annexe. The load conveyed, at one time, by this engine, occasionally amounted to 45 tons. A large portion of the western Annexe was devoted to the display of engineers' tools, of every form and size, and for every description of work—either incision, excision, or circumcision. The principal machine in Whitworth's group was a large recently-introduced machine called a self-acting radial drilling and boring machine: the radial arm carrying the drill spindle is movable through an arc of 200 degrees; it is attached to a vertical slide worked by a rack and pinion, with worm and wheel on the main frame; the drill spindle works through a tube, and is adjustable horizontally by a screw and nut from one radius to another; it has a variable self-acting down motion, and retains its connection with the driving motion in every position. Shanks and Co. exhibited two drills of novel construction: the multiple drill and the turnstile drill. They had here also one of their large double slotting drills, with two tools working toward each other: it is capable of making a slot eighteen inches long. Here were shown the file cutting machines of the Manchester File Making Company. The name of Nasmyth is inseparably connected with the steam hammer; and Nasmyth and Co. were represented extensively in the Exhibition. Of the modifications, Robert Morrison and Co. displayed their double-acting steam forge hammer. The main point of improvement in this apparatus is comprised in the fact that the hammer bar and the piston are forged solid together. In other cases, where a different mode of attachment is adopted, the piston and piston rod have sometimes, from the violence of repeated strokes, parted company. In this instance such a catastrophe is next to impossible. The steam cylinder is firmly bolted to the single frame which supports the whole. This frame also contains the steam chest steam passages, and the steam

and exhaust pipes. The hammer bar is furnished at its lower end with a claw for holding in the different faces or dies required for various kinds of work. The piston is simple in its construction, and two small steel rings fitting into grooves on its circumference make it steam tight. Above the piston the bar is planed flat on one side, a corresponding flat being left in the cylinder cover. This arrangement has the effect of keeping the bar and the hammer face constantly in the same relative position to the anvil. On the top of the hammer bar there is a small roller which works in the slot of the lever. The lever, with the aid of a pair of links and a slide-rod, gives motion to an ordinary box slide, which admits steam alternately above and below the piston.

The principle on which Siebe's ice-making machine is constructed is the removal of caloric by evaporating a volatile fluid in vacuo, and the condensation of the vapor by pressure. A strong solution of brine is employed as a carrying agent, which, after having been passed through the evaporating vessel, flows along the refrigerating trough, in which are placed vessels full of pure water, which becomes ice by the absorption of caloric.

The patent Hoist Company exhibited a safety cage in which Watt's governor regulates the velocity of the cage in transit. The advantage obtained by this mode is that when a chain breaks, the cage gradually descends. Mr. Clarke's improved fire escape reaches eighty feet high. The underneath part of the centre ladder of this fire escape is encircled by canvas rendered incombustible by being saturated in alum and chloride. A wire gauze further protects the canvas from the effects of flames. Into the wooden steps of the ladder are inlaid wire rope, sufficiently strong to bear the weight of several men. The improvement in Clarke's fire escape is in the lever-bars for raising the second ladder, which works on quadrants: this fire escape is so light that one man can wheel it easily.

Manlove, Allnutt, and Co. exhibited some complete and ingenious machinery for completing the manufacture of sugar. The effect is produced by centrifugal force; the pans containing the sugar being caused to revolve at the rate of 1,000 revolutions per minute, by which means the treacle and molasses are perfectly separated.

The display of machinery for making paper was very large. One of the most complete and beautifully-executed machines was constructed by Bryan, Donkin and Co., of Bermondsey, and intended to manufacture an endless sheet of paper of any width under seven feet. The above machine is capable of making an endless sheet of paper twenty miles long in about twenty-four hours: the actual superficial area of this sheet of paper would be about seventeen acres. The combination of machinery exhibited by Donkin not only makes the paper complete from the pulp, but also gives to it the necessary water-mark, and cuts it into sheets of any desired size and form.

*Young's Type-Composing Machine.*—The inventor describes that this type machine is provided with separate compartments called "reservoirs," for all the letters of a font; each reservoir being provided with a small lever, which, by means of a rod, is connected to a key like those used in a pianoforte. When a key is struck by the player, it pushes a type out of the reservoir by means of the lever mentioned above, and the type is thus caused to slide down an inclined plane, and thence into a receiver, where it is set up side by side with other types, by means of a beater. Thus, each type or letter can be set up by a player in the order required by a compositor's copy. This is now done with a speed of from 12,000 to 15,000 types set up in an hour's time. The justifying apparatus is intended to replace the compositor's stick. The compositor places the galley filled with the long lines of type set up by the composing machine, slides one of them into the apparatus, divides it into the proper width of the page, and having justified it, moves a handle which depresses the completed line, and thus makes room for a succeeding one. It is found that a compositor can by this means justify at the rate of 4,000 to 6,000 types per hour.

The distributing machine separates all the different letters of a font that may have been used for printing, into different channels ready for use in the composing machine. This is effected by one or more pairs of nippers, which takes every type singly from the reservoir in which all the types have been placed, and allows it to slide down an inclined plane, the upper part of which moves on a hinge. The thin or lower-case types slide down to the bottom of the fixed inclined plane, but the thicker or upper-case letters are retained on the movable incline, which, on being raised, drops them into an appropriate receptacle, whence they are then taken and redistributed by passing down a separate channel of the inclined plane. The thin, or lower-case letters, that have arrived at the bottom of the inclined plane, are pushed into the grooves of a revolving chain. This chain in moving passes underneath plates which are made of different widths in order to cover only certain nicks cut or cast on the edge of the types, and situated in different parts of their length, from 1-16th to 12-16ths of an inch from the tail of each type. When, therefore, a type passes underneath a plate, which allows its nick to be exposed, it is pushed from off the chain by means of a scraper which passes over the plate on to a tilting inclined plane. This plane in its descent allows the type to slide down, by means of an inclined channel, into a receiver, where it is set up by means of a beater, as in the composing machine. The distinguishing nicks are somewhat like those used by typefounders; 71 per cent. of the types require only one nick, 20 per cent. only two nicks, and the remainder have three nicks. One distributing machine, attended by two

boys, will distribute and prepare for the composing machine from 14,000 to 18,000 types per hour.

Mitchell's composing and distributing machine was also exhibited. This machine has been for many years in practical operation in this country, and the description of it can be found in Appleton's "Dictionary of Mechanics."

*Folding, Pressing, and Stitching Machine.*—This compact little folding machine, a Swiss invention, is constructed to make a perfect register, and to fold printed or white sheets of paper with far greater precision than the most experienced hands can do it, at the rate of 1,400 to 1,500 sheets of any size per hour; and it presses and stitches the sheets at the same time.

The machine works as follows: The sheets are put singly by a boy under the points of the machine, in the same manner as with the printing machine. A knife moving nearly vertically up and down takes hold of the sheet lengthwise in the centre, draws it through a slip in the table, and the first fold is made. The knife returns instantly, and the sheet is taken by a second vertical knife, moving from the left to the right, folding it at a right angle to the first fold. The double-folded sheet is now opposite a pair of ribbed rollers (cylinders). Before the third fold is made, the stitching commences as follows: Two needles, provided with hooks, pass through the middle of the sheet, at about an inch distance from each other, drawing the cotton through, which is unwound from a bobbin, and cut to the required length by a peculiarly constructed pair of shears; the sheet is then folded a third time—viz., a knife in the shape of a T, acting horizontally, and consequently, at a right angle with the second knife, takes hold of the middle of the sheet, and pushes it between the above-mentioned ribbed rollers, whence it is passed directly to another pair of polished rollers, from which it comes glazed and pressed on to the table. The machine works very correctly, and folds the largest as well as the smallest sheets, and both the stitching and pressing apparatus, or each singly, may be detached by loosening a single screw. It can be worked either by steam or hand, a boy being sufficient for that purpose. The same exhibitor showed a second folding machine, which feeds itself by an air or sucking apparatus that takes the sheets one by one from off a pile, under the horizontal folding knife, thus enabling it to fold 8,000 sheets per hour.

AGRICULTURAL MACHINES AND IMPLEMENTS.—

Cultivation by the steam engine was the paramount feature of this department; one gallery and part of another being occupied by two rival systems of steam-ploughing mechanism. Fowler contributed the steam engines, with their wire ropes, ploughs, and grubbers, of which about 150 sets are now at work in this and other countries. Here, too, were the engine, windlass, grubbers, and new balance ploughs of the Howards, of Bedford; their steam cultivator and new implements for the hay harvest.

America has produced a greater variety of reaping and mowing machines than we English have done; most of our new notions in knife, or gearing, or delivery, having come a voyage across the Atlantic. In the United States Court we accordingly found several ingenuities of this order.

A striking object among these inventions was the reaper of Mr. M'Cormick, which advertises itself as one of 40,000 made and sold in one shop. The platform is of a quadrant figure; the reel has but three, instead of four blades, the place of the fourth being occupied by a rake, which by a very peculiar but really simple and easy movement is made to sweep over the platform, delivering the cut corn at one side. Mr. Aveling, of Rochester, showed his simply-contrived and practically-successful locomotive for common roads, of which, it is said, forty are already in constant use.

Denmark contributed a novelty in the shape of long shallow iron pans for holding milk in large dairies. A screw at the farther end enables the pan to be slightly raised for emptying, and a broad blade of thin wood reaching across the pan and supported by rollers running along the edges of the pan, is drawn from end to end when the cream is to be skimmed off the milk.

In the Australian Court was a Victorian reaper from Melbourne, in South Australia. The machine exhibited resembled the ancient Roman reaper. A box, upon a pair of wheels, is propelled by horses and a pole at the side; the forward end is armed with an iron comb, which does not, however, snap off the ears of the standing crop, but holds them, while the rapidly revolving beaters of a drum, like that of a threshing machine, strip out the kernels of ripe grain. The box receives the corn; sometimes a fan (driven like the drum, by wheels and a strap, by the rotation of the carriage wheels) winnows away the chaff, and the produce is thus collected ready for the market.

**CIVIL ENGINEERING, ARCHITECTURE, AND BUILDING CONTRIVANCES.**—The great number of the contributions by engineers were models of iron bridges and viaducts, of which the principle of construction is remarkable for that subserviency of other considerations to one of rapid completion, which is generally of importance to shareholders. In most of these models, one of the forms of the lattice-girder is used, with piers likewise of iron construction. The Beelah Viaduct, Westmoreland, was illustrated in a model. It was designed by Mr. T. Bouch, of Edinburgh. It is 1,000 feet long and 200 feet high in the deepest part of the valley, and was erected in four months. Three years, say the exhibitors, would have been required for the erection of a viaduct of brick or stone.

Several models and photographs of suspension bridges were shown. The chief work was a railway bridge, that of the Niagara—still not sufficiently appreciated, we think, by British engineers.

An admirable series of models contributed by the French Minister of Public Works, comprised representations of the sea walls of Cherbourg and the harbor of Marseilles. The system of construction in both cases, if not identical, is closely analogous. In the greatest depths where the disturbing action of the wave ceases, the smaller stones are placed, or, more properly speaking, sunk, being allowed to assume their natural inclination. Above these again the larger material comes, increasing in bulk in proportion to the action of the waters; the largest masses of natural stone being surmounted, and the outer surface faced by enormous blocks of concrete, of which also the superimposed masonry is principally formed. This artificial stone is composed of the debris from the quarries mixed with hydraulic lime.

In the instance of the creosoted woods shown by Mr. J. Bethell, however, the evidence is clear that piles, fourteen inches square, used at Grimsby, half the substance is found to be eaten away by the seaworms, in ten years or less, where the pile had not been creosoted; whilst the creosoted pile, after exposure for the same time, is shown to be in the original state. The collection of specimens included sections from railway sleepers after twenty-one years' constant use; the wood being scarcely injured.

Clay-ware pipes, by Zeller, of Ollwiller (Haut-Rhin), enamelled, and bitumenized paper pipes, by Jaloureaux, of Paris, of good manufacture, for the conveyance of water and gas, were exhibited. The bitumenized pipes are favorably reported on in Paris, as regards durability, after four years' trial; and elasticity is one of their advantages.

**MODELS, WEAPONS, &c.**—In the court devoted to these articles the visitor could study, almost in a glance, the progress of naval architecture for nearly three centuries past. All kinds of these models were here, from that of the Great Harry down to our last and greatest ship, the Warrior, with lines as fine as a Dover packet.

An important American invention was shown—a series of beautiful little working models of the various machines used in Thompson's patent for making boats by steam, which do all, even to curving and bevelling the edges; so that a rough board passing in at one end of a machine comes out at the other, not only curved, but bevelled and planed.

The new gun, invented by Sir William Armstrong, is a rifled breech-loading 70-pounder, but one in which the chamber ventpiece and screw are entirely dispensed with. The gun is built up of wrought iron coils and rifled in the usual manner; but in the breech on both sides two narrow openings are cut, into which are fitted two wedge-shaped masses of iron with handles. These, when drawn aside, have openings in them corresponding to the bore of the gun, which can then be seen through from end to end, a hollow rifled tube. The shot and powder are then inserted in the ordinary

way at the breech, and the foremost of the sliding iron wedges we have mentioned drawn across so as to close the tube. The second and most massive wedge is then drawn into its position so as to jam both tight, and the gun is ready for firing. By a simple contrivance connected with the lock of the gun, which slides down a powerful steel bolt that keys the two wedges together, the piece cannot be fired till both wedges are in their place, nor can they be withdrawn until this again is lifted.

Near the Armstrong gun were shown sections of shells of all sizes, both time and percussion. The time shell is adjusted by distance—that is, the fuse is cut short to burst the charge so many seconds after it leaves the gun, every second representing a space of four hundred yards traversed. Thus, after one or two shots for “range,” the shell can be burst to a nicety of fifty feet. The percussion shell, as its name implies, explodes instantaneously on touching any obstacles after it leaves the gun.

Near to this were exhibited the guns of Armstrong's great competitor—Mr. Whitworth, whose gun is still that which has attained the longest range and greatest accuracy, and is still the only piece that has sent as light a shot as 70 lb. through 4½ inches of solid iron plate. The Blakeley gun, also in this court, is a very good piece of rifled muzzle-loading ordnance, very similar in principle to the *canon rayé* of the French. Even, however, as a rifled muzzle-loader it is inferior to Whitworth's, which has the advantage of being a breech-loader as well. A large wrought iron gun was exhibited from the Mersey works, which, as a perfect triumph of forging, should have been shown side by side with the double-throw crank of the same firm. The shells of the monster mortar—shells which, when loaded, weigh as much as 25 cwt.—are another instance of extravagant invention of which this court offers as many samples as any other in the building. Every kind of breech-loading small arm was, of course, to be found here. And here, by comparison, might be seen the superiority of the American invention of Mr. Storm over others. In this piece there is nothing special in either the lock, or stock, or barrel; the only invention, in fact, being the breech-loading apparatus, which is applicable to any and every barrel, at a cost, it is stated, as low as some 16s. each. The breech, about an inch, or an inch and a half in length, is fitted to the barrel by an ordinary hinge, which is thrown up or open by a movement of the finger or thumb, the charge inserted, and the breech closed. It has been tried by some of the highest professional authorities on musketry, and has been pronounced perfect.

Mr. Lancaster exhibited his oval-bore cannon, with shot and shell for its service. The system of construction is briefly described thus: “The inside of the barrel is cut by proper machinery in spiral form, the difference between major and minor axis being .012 of an inch.”

A very interesting collection of guns and projectiles was contributed by the Whitworth Ordnance Company. The guns ranged in size from the 1-pounder to the 70-pounder, and comprised examples of both breech and muzzle loaders. In every case the bore is hexagonal in its cross section, and in the rifling the pitch is equal to twenty times the diameter of the bore. Messrs. Whitworth state the range of their 12-pounder rifled canon, with a 12 lb. shot, and 1½ lb. of powder, as follows: At point blank, 380 yards; at 1° of elevation, 900 yards; at 5°, 2,600 yards; at 10°, 4,500 yards; at 20°, 7,000 yards; at 35°, 10,000 yards, or about 5½ English miles!

A very beautiful gun of small calibre, and constructed of cast steel, was forwarded from Russia. A label attached to it informed us that it has withstood a test equivalent to 4,000 charges. This argues a degree of tenacity in the metal of which it is composed, second only—if second, indeed, it be—to that of which the Prussian cannon are made.

Prussia contributed an interesting collection of gun barrels of the famous steel of Messrs. Krupp, of Ensen. They were shown, together with various specimens of the metal, including one ingot of thirty tons weight, in the western Annex. “When we examine the illustrations here offered of the texture (so to speak) of this steel, we cease to be surprised that the guns made from it have borne with impunity the rigid test that has been applied to some of them. This consists of sealing securely the muzzle of the gun, after having previously filled the barrel with powder; when, on application of the fuse, the whole charge burns away harmlessly through the touchhole, leaving the barrel perfect and flawless.”

*New Cartridge.*—A new seamless skin cartridge, the invention of Capt. M. Hayes, excited much interest. The advantages which it possesses over ordinary cartridges are its waterproof qualities, greatly increased facilities of loading, cleanliness, and cheapness. In addition to the natural damp-resisting properties of the skin used in the manufacture, it is chemically prepared, so as to be impervious to wet. The ordinary paper cartridge cannot resist water, and naturally absorbs moisture. The facilities in loading gained by this invention are extraordinary. The cartridge requires neither biting, tearing, nor puncturing; but by one action is passed entire, viz., powder and ball in one complete whole, into the muzzle of the arm used, and goes clean down to the point of ignition. The spark from the percussion cap penetrates the skin, and the charge is exploded without the chance of hang or misfire.

*Marine Engines.*—As might naturally be expected, the most important part of the exhibition of machinery was that where the object was marine propulsion. There were no less than seven pairs of marine engines fitted up complete for work, the aggregate power of which could not be less than 2,000 horses. But



in their construction they presented nothing of novelty, being but examples from the best makers which may be found described in Tredgold and Bourne on the steam engine.

**GAS ENGINEERING.**—One of the best illustrations of the progress effected since 1851 was in the number of exhibitors of fireclay gas retorts at the Exhibition. This has been caused through iron gas retorts being superseded by earthenware retorts in almost every town exceeding 10,000 inhabitants.

Mr. G. Glover, of Pimlico, exhibited a meter, by which quantities of gas so minute as from  $\frac{1}{100}$  to  $\frac{1}{1000}$  part of a cubic foot can be measured with precision each second.

Mr. Prosex exhibited his oxyhydrogen lime lamp, the identical one used for three months at the South Foreland lighthouse.

In 1851 the only paraffine candle exhibited was made from turf. The considerable display made by Mr. Young, and Messrs. Field, and many others, of blocks of paraffine and candles, proves the manufacture of this article to have arisen during the past ten years.

Mr. Shepard's magneto-electric light was shown. This remarkable light has been two winters in use at the South Foreland lighthouse, and is now fitted up by the Trinity Board at Dungeness. The light produced is intense—sufficient, it is stated, in a revolving lens giving off six rays, to enable any person with average sight to read at a distance of ten miles.

**PHILOSOPHICAL INSTRUMENTS.**—Amongst the general instruments exhibited were cloud mirrors, sunshine recorders; and a galactoscope for measuring the transparency of milk. The Right Hon. Robert Lowe showed spectacles which magnify without glass or any other refracting medium; and Dr. Lankester exhibited an ozonometer for registering the hourly variations of ozone.

The improvements Mr. Wenham has effected for microscopic objects deserve mention. No longer a mere flat image is produced; the binocular microscope, by a contrivance for the use of both eyes, gives perfect stereoscopic relief, and at the same time saves much labor to the eyes of the spectator.

A machine was exhibited by Mr. Peters for microscopic writing. The words to be written microscopically are written in pencil, in ordinary characters, on a sheet of paper at the bottom of the instrument. But the pencil with which this is done communicating by a series of levers and gimbals with another minute pencil and tablet at the top, is so graduated that a stroke of a quarter of an inch at the bottom is only a stroke of a quarter of a millionth of an inch at the top, the shape and character of both marks being nevertheless precisely alike in outline. The object of the machine is chiefly to mark banknotes with certain minute signatures for the prevention of forgery. Close by this curious instrument was Mr. Babbage's calculating machine, which will work quadrations and calculate logarithms up to seven

places of figures. Messrs. Scheutz, of Stockholm, have improved upon it to such an extent as not only enabled the machine to calculate its tables, but to print its results. This improvement was at once bought up by the English Government, but it is not now shown at the Exhibition.

Negretti and Zambra showed instruments entirely new, and most of the important ones. Among these was a thermometer so exquisitely sensitive as to rise at once upon the approach of the hand within two or three inches; this was made specially to test the temperature of the body and coils of the python during her attempted incubation at the Zoological Gardens.

M. König showed a wonderful collection of instruments applied to the illustration of the theory of the conduction, undulation, and vibration of sound. By a most ingenious but simple instrument—a common glass cylinder, coated with fine lampblack, and applied, turning, to a tuning key when vibrating—M. König makes sound its own printer. From the impressions left on this cylinder all the different vibrations and undulations of sound between A and G are here recorded from their outset to their latest tone, have been made to register themselves, and from the records thus left a most beautiful series of acoustic charts has been drawn out.

M. Perreux exhibited a spherometer for measuring the curves of object glasses. This instrument is of such extreme delicacy, that when adjusted to zero, even placing the hand on the ground glass plane beneath, from which the slender index works, is sufficient to deflect it instantly. None in the foreign department showed good photographic negatives of microscopic objects but Roncoli, of Bergamo, in the Italian section. Some of these instantaneous photographs of the magnified blood and anatomy of the most minute insects were among the most wonderful *tours de force* that this chemical art showed in the building. In the French department was the calculating machine of M. Thomas—the Babbage of France. It is so small as to fit in a compass not greater than that of a good musical snuff box. Yet, by simply winding a handle, 18 seconds suffice to multiply 8 figures by 8; to divide 16 figures by 8 figures only 24 seconds are required, and a square root of 16 figures is obtained within a minute! And all this is done by turning a handle rapidly, and the price of the whole apparatus is within the reach of most buyers.

**PHOTOGRAPHY AND PHOTOGRAPHIC APPARATUS.**—Mr. Warren de la Rue exhibited his most interesting series of photographs, showing the progress of the late total eclipse of the sun as seen in Spain.

Col. Sir Henry James, director of the ordnance survey, showed specimens of "photo-zincography," for the reduction, enlarging, and printing of maps and plans. Sir Henry showed adaptations of it to the production of facsimiles

of ancient MS., and one of a page of Domesday Book. The photograph, by a simple and cheap process, is transferred to a zinc plate, whence any number of copies can be taken off by the ordinary plate printing process.

F. Joubert exhibited a series of very beautiful pictures burnt in on glass, a marvellous adaptation of the photographic art in an absolutely new direction. By a pure photographic process he produces on the glass, in ceramic colors, a picture, which, by exposure to heat in the furnace becomes burnt in like any other picture on glass or china. By a careful and artistic manipulation he has been able to produce effects in several colors. The process has been perfected, and a cheap and artistic ornamentation of our windows is brought within the means of the many.

**CLOCKS AND WATCHES.**—The great dial around the stained glass window at the eastern end of the nave, measuring nearly 40 feet in diameter, was the first lion of this class. It was worked by a clock made by Dent.

Another gigantic work, termed *par excellence* "The Great Exhibition Clock," was placed in the central tower of the south side of the exhibition building. The maker is M. Benson, of Ludgate hill. Its special peculiarity is a new double lever remontoire, the application of which diminishes the friction or retarding force, and allows of great motive power, even to the extent of 20 tons, being used without disturbing the time-keeping qualities. In all cases where the works of a clock are at a great distance from the dial, as in this case, the outer dial being 300 feet from the works, a great motive power is requisite.

The great watch and clock makers of Clerkenwell exhibited in full strength. After Clerkenwell, but at some distance, came the watches of Coventry; and last of all, the prettiest and cheapest, but much inferior, watches of Switzerland. In this class all the great watch and clock manufacturers of England showed their masterpieces of workmanship. There were reversible chronometers, steam clocks, marine chronometers, astronomical clocks, geographical clocks, silent clocks, skeleton clocks, Lilliputian alarm clocks, electro-magnetic clocks, keyless watches, electric clocks, mercurial timepieces, clocks showing mean time and longitude at important places, and galvano-magnetic clocks; and gold and silver watches of every description.

**ELECTRIC TELEGRAPHS AND ELECTRICAL APPARATUS.**—It has been aptly observed that the practical influence of electrical inventions met the visitor at the very threshold of the Exhibition Building, where the "Magnetic Tell-Tale" of Prof. Wheatstone was attached to some of the turnstiles, and this, in a measure, controlled the financial department. This instrument was worked without battery power of any kind. The electricity was generated by a peculiarly constructed magnetic machine, so connected with the axis of the turnstile as to discharge a

current of its force at each revolution of the stile. Thus, each visitor, on passing through it, unconsciously and telegraphically announced his or her arrival to the financial officers in whose rooms were fixed the instruments for receiving and recording the liberated current, which latter was conducted thither by a line of copper wire laid along the building between those instruments and the turnstiles, and metallicly connected to each. The registers thus obtained formed a complete check upon the money taken at the doors.

The great improvements and numerous inventions in electric telegraphy during the past ten years were strikingly shown by the various new instruments exhibited by the Universal Private Telegraph, the British and Irish, the Submarine, and other telegraphic companies. Prof. Wheatstone's ingenious and beautiful Domestic telegraphs were shown in working order, and many inventions and contrivances to utilize this valuable discovery. Mr. Tyer exhibited his patent Train Telegraph. The apparatus for the use of the signalmen comprise a telegraphic needle for each line of rails in each direction, and a bell and gong, having different sounds, the one for the up and the other for the down line of rails in each direction. The bell or gong is used to draw attention to the approach or passage of a train, and by the number of beats employed, to describe the train: while the needles are used solely to denote either "line blocked," or "line clear;" and no signalman can alter his own instrument, it being the duty of each signalman to work the needles of the signalmen on each side of him.

The most interesting and advanced of these instruments were those which worked more or less automatically. The automatic system of Mr. Allan consists of three machines; the punching machine is the first of these, and by this the ribbon paper to be passed through the sending machine is perforated with holes, representing dots and strokes of the Morse alphabet, at those points only where the current is required to mark on the unperforated ribbon at the receiving station; next is the sending machine, into which the perforated paper is introduced. This machine winds up its own clockwork, whereby the paper is drawn forward, and stops of its own accord when the message is completed; and lastly, the receiving instrument at the distant station, which is also so arranged as to start its own machinery on receiving the electric impulse, and stop it when the perforated paper at the other end has passed through the sending apparatus.

The British and Irish Magnetic Telegraph Company exhibited a system of controlling turret and other clocks, the clocks being controlled only, and not moved either in whole or part, by electricity. The three clocks shown were in all respects, excepting the pendulum, of ordinary construction, and would go without the electric current, keeping their own time. The pendulum is a hollow electro-magnet, oscillat-

ing over or around permanent magnets. When a current is sent, second by second, from a controlling clock, the temporary attraction between the electro-magnet and the permanent magnet compels the controlled pendulum to copy the vibrations of the controller, even though there may be a discrepancy of several minutes in their daily independent rates. The above company also sent the Acoustic Telegraph, the signals being produced by strokes on a pair of bells of different tones.

Mr. C. F. Walker, the telegraph engineer, exhibited a pair of the bells, of which some hundreds are erected on the South-Eastern Railway, for signalling trains. There is but one movable piece, the hammer which strikes the bell. The battery employed is a one-fluid-battery, the negative plate being platinized graphite. A counting index is attached to some bells to count if the signalman is absent or distracted. Two instruments record the signals. One of these drops black and white balls into a groove for the signals, and spotted and blue for the hours and quarters. The other imprints red and black marks on cotton thread for the signals, and the two combined for time marks. Mr. Walker also exhibited a Graphite Battery in work; an audible system of Train Signals; an index for counting, and an apparatus for recording them.

Messrs. C. and S. A. Varley exhibited a large ebonite Electrical Machine: the disc is three feet in diameter, and is excited by a soft amalgam composed of zinc, tin, mercury, and lead, to give out sparks from 16 to 20 inches in length.

**SURGICAL INSTRUMENTS AND APPLIANCES.**—All the well-known manufacturers of Great Britain were represented in the Exhibition. Weiss and Son exhibited among the novelties a modification of the Ecraseur, an instrument by means of which the tissues of the body can be divided by a wire or chain saw, worked by a sort of windlass action. The power here is obtained by an endless screw, and is so great that no part of the frame except the bones is capable of withstanding its force. As it cuts in a slightly uneven manner, and the constriction is necessarily very great before incision commences, there is little chance of important hemorrhage happening after its employment.

The Artificial Limbs shown by Masters were of exquisite workmanship. One of the artificial legs was of wonderfully small weight—viz., 2 lb. 7 oz., constructed of willow wood coated with leather, and furnished with strong though light articulations.

Among the French exhibitors, Charrière invented for M. Roger, the celebrated tenor of the Opéra Comique, an Arm. The novelty in its construction consists of an extra joint made in the centre of the forearm, to which a spring, with cords, is attached; and the cords, passing over the opposite shoulder, give the wearer the power of turning the hand and pointing the finger. In the French gallery we also noticed

the apparatus of Dr. Sales-Girons for the Pulverization of Liquids: by means of compressed air a small stream of mineral or medicated water is driven against a metal plate with such rapidity, that on striking it, it breaks into a finely-divided state, or, in other words, into a mist which the patient can easily inhale. An instrument was invented by Dr. Marey, that not only shows the pulsation of an artery by the oscillation of a lever, but also draws on paper the curve defined by it at each beat of the heart.

Leiter, of Vienna, had tubes used after the operation of tracheotomy; they have a valve which allows the patient to speak, notwithstanding the opening in his windpipe. Dr. Hebra's Bath, in which he keeps patients for such a period as eight weeks, is a curiosity in its way. He was first led to adopt this in a case of extensive superficial burn; and devised immersion in tepid water, constantly changing—and was quite successful in his treatment.

**SANITARY APPLIANCES.**—Mr. Thomas Spencer exhibited the Magnetic Purifying Filter—the discovery is, that magnetic oxide of iron, loadstone, is nature's chief agent of purification, and that any stratum containing iron also contains a small percentage of this oxide; and that where the oxide most abounds,—water is purest. The oxide attracts oxygen; the molecules of that gas become polarized, or ozone; the latter attracts the carbon of moist organic matter; and carbonic acid results.

Dahlke's patent Silicated Carbon Filter, is formed of a combination of carbon with silica, as existing in the Torbane Hill mineral, which is represented as immensely more effective than mere carbon, both as an oxidizer and a promoter of chemical combination generally: carbon, indeed, acting mainly by absorption, or not chemically, being subject to saturation, and absorbing the carbonic acid. Instead of taking away the gas, the silicated carbon causes production of it, whilst nitrogenous products become changed. These filters have been adopted by the Metropolitan Free Drinking Fountains Association.

**MUSICAL INSTRUMENTS.**—The Pianoforte is given to outside decoration. This Exhibition shows, in its ample display of woods hitherto unknown from every quarter of the globe, what exquisite varieties of color and grain lie at the service of every cabinetmaker, though he be bent on no such fine fancies. Meanwhile, the general quality of instruments is improved.

An American improvement merits special mention. Mr. Hulskamp exhibited a modification of the instrument, founded on the observation that tension was an important element in the vibratory action of bodies. Accordingly, applying, by the use of screws, a straining power to the sounding board of a pianoforte, he is enabled to increase his vibration so materially, that a horizontal pianoforte exhibited by him, two feet shorter than the ordinary grand, has all the power of the larger instru-

ment. The whole result thus produced, however, is not solely due to the tension applied to the sounding board, but is in part referable to the oblique braces which transmit the vibrations from the frame on which the strings are stretched to the centre of the sounding board. Mr. Hulskamp has applied the same principle of construction to the violin, increasing in a remarkable degree the volume of tone.

In organs again, while there remains much to be done, there have been great improvements both in point of combination and to facilitate the manual and pedal execution. M. Sax had his usual case of carefully made brass instruments. England, we fancy, carries off the palm in flutes.

The Musical Boxes from Geneva attracted great attention in the Swiss Court; and Auber and Linton showed here a beautiful piece of mechanism which, though no novelty, drew a crowd of admirers. It was in the shape of a small musical box, just large enough for the waistcoat pocket, out of which, when the lid was opened, popped up a pretty little bullfinch, who piped a song, fluttering his wings in the most natural manner possible. The plumage, the action, and the peculiar note of the bird, were imitated with wonderful exactness. It was a benevolent idea of the proprietors to make this mechanical wonder subserve "all mankind's concern," charity, by announcing that whenever the sum of five shillings was raised among the visitors, the bird should perform, and the fund so collected be appropriated to the benefit of the distressed cotton districts. He seldom continued long without an audience, and sometimes realized from 10*l.* to 12*l.* a day toward the Cotton Districts Fund.

**MISCELLANEOUS MACHINERY.**—*Cotton-Spinning Machinery.*—This important branch of machinery was largely represented; and Dobson and Barlow, of Bolton, contributed a fair quota of the whole. They exhibited, in fact, a series of machines for opening and cleansing, preparing and spinning cotton. The first is named a Cotton Spinner, and it is adapted for spinning and cleaning long or short stapled cotton. The feeding parts and the inside gratings, are of a novel construction, the object in view being to open out and clean the cotton without injuring the staple. The second is called the Single Scutcher, and it is supplied with feeding rolls: the merit of the rolls consists in their holding the cotton sufficiently firm without breaking the seeds or shells. Then follows the Breaker Carding Engine, which is a combined patent machine: Wallman, of the United States of America, and Dobson and Barlow, each having a share in it. Its chief merits are that the cotton is well opened and cleaned by the working rollers, before the upper rollers will allow it to pass the self-slipping top-flats: these flats can be taken out at pleasure by the attendant, and readjusted without the use of a screw key. A Finisher Carding Engine stands next, and it works automati-

cally—an improvement on the plan of stripping flats by hand, as is usually done. Ashworth's patent Lap Machine is used for making laps for the finisher carding engine, and combing machine; and a grinding apparatus is so contrived as to grind two rollers and a flat at the same time.

There was an extensive collection of Carpet weaving Machinery exhibited. The Power Loom by Tuer and Hall, of Bury, near Manchester, for the weaving of pile, velvet, patent tapestry, or ordinary Brussels carpet, any width required, either with or without jacquard, was shown in operation. All the working motions are outside the loom, except the crank from which it is driven; by this means free access to the working parts is obtained, and a hitherto much complained of inconvenience removed. It will admit larger yarn beams in the same space than any other loom we know of. The wire motion inserts forty-five wires per minute, at two picks per wire; it recommends itself by the facility with which it inserts the wires on which the loops or pile is raised, and by its simple arrangement for holding the wires when inserted, withdrawing and transferring the point of the wire for reinsertion. The whole of the motion is governed in its action by one cam. It produces six yards of carpet per hour, much more than ordinary looms, and requires less space than most of them with the same width in the reed; six such machines may be driven by one horse's power. This loom is also applicable to the weaving of Utrecht velvet, for the lining of carriages, omnibuses, &c.

From Switzerland two Looms were both exhibited at work, in weaving broad ribbon. In one the pattern was a portrait of her Majesty (black lines on a white ground); the other produced the royal arms in beautiful colors, also on a white ground. This latter machine weaves several ribbons at one time. It is a beautiful piece of workmanship, but so elaborate and apparently complicated that it is perfectly bewildering to a stranger to endeavor to trace out the meaning of its parts—such piles of perforated cards, such masses of threads in the gears, and such innumerable little bobbins and shuttles. It is in machines of this kind that we see the real genius of the French or Swiss mechanic develop itself.

**AMERICAN MACHINERY.**—Among the machines was Conroy's Cork Cutter: the man in charge simply puts down a square of cork on a small ledge, and as the machine works, two fingers are pushed out, which grasp it, and fix it on a rapidly rotating pin, where it is applied to the edge of a circular knife, revolving horizontally: in a couple of seconds the square assumes the desired shape and size, and immediately drops into a reservoir beneath to make room for another. A man and a couple of boys can cut 150 gross of corks with this machine in a day. The Rope-making Machine, which stood next, compresses a ropewalk of some 800 or 900 yards into about

8 feet, and it spins a 12-strand rope quite as stout and in much less time than it could be done by hand. Close by the rope spinner was a Machine for Shifting and Securing Machinery Belts, by which, no doubt, many accidents may be prevented. By pulling a cord the belt is moved either on or off the drums; and as the guides move they are secured in their place by a self-acting lock, so that the belt cannot slip either one way or the other. Eckell, of New York, sent one of his new Presses, by which 1,000 lbs. of cotton may be pressed into 18 cubic feet, or 800 lbs. of hay into a truss of 5 feet by 2 feet, with a height of 32 inches, in a space of four minutes, and with a less expenditure of labor than by any other press yet invented. They are capable of exerting from 100 to 1,000 tons pressure, and one man working alone can bring 100 tons to bear. The machinery is very simple, and may be applied with equal advantage to presses for extracting oils. Hansbrow's California Pump was chiefly distinguished for the ingenious adaptation of the leverage, so that a child might work it. The stream rises on the slightest movement of the handle, and when full power is put on, it will throw a stream from a depth of 80 feet to a height of 85 feet through 50 feet of hose.

Among the most important machinery was a power loom for weaving tufted carpets. In a practical point of view it was perhaps one of the valuable novelties in the department. By a single throw of the shuttle, it will insert, weave in, cut off, and complete one whole range of figuring tufts across the width of the fabric in less time than is required for the making of a single tuft by the hand loom. Any medallion design can be woven in parts, which may easily be united so as to have the appearance of being woven in one piece, as the salvage produced is such that when sewed the seams are not visible. The strain on the material is so slight that common worsted or woollen yarns of any quality may be used, so that the cheapest kinds of carpets may be produced in it. The Earl Granville has publicly stated that it is destined to achieve greater results than any other machine in the building.

Besides these there were various other contrivances of minor importance, but all displaying wonderful ingenuity.

The Pianofortes were highly praised by experts.

Mr. L. A. Bigelow, Boston, Mass., exhibited several machines connected with bootmaking. First was a machine for splitting the leather, or rather, as we would describe it, for paring the leather intended for soles to a uniform or required thickness. This is effected by passing the leather between two rollers, one grooved and the other smooth, behind which is a knife that may be adjusted in relation to the frame according to the thickness of the leather required. The cutting is accomplished rapidly, and with more precision than can be done by the hand and knife. Then we had a machine

for cutting up the leather into soles, which it does at the rate of twenty pair a minute, all fitted exactly to the last, without the use of a hand knife, and the edges sufficiently smooth to finish. Further, there was a "Heel Trimmer," that is, a machine which, carrying the boot or shoe on a pivot, subjects it under a circular motion to the action of a cutter, which in a minute pares the rough edges to the form of heel, whatever the thickness may be. At last came the Sole Sewing Machine, much on the same principle as the sewing machines for lighter material, with which the public are now familiar. Of course it is more ponderous and powerful, having a force to penetrate the thickest leather, or even a board half an inch thick. It uses a heavy waxed thread, drawing the thread more tightly than can be done by hand, and making the work both strong and solid. This machine will sew on the soles of one hundred and fifty pairs of boots or shoes per day.

Another very simple contrivance of great use was a machine for addressing newspapers, exhibited by Mr. Sweet, of New York. A wooden disc, from the edge of which project all the letters of the alphabet, is made to revolve by a treddle; a small wooden block is pressed against the letter required, till the address is cut out on the face of the block. It is then placed along with hundreds of others similarly cut upon an endless band, and having been inked, the band carries them round; and as one by one they descend on a small table, the newspaper, or whatever is to be addressed, is pressed against them by a pressure of the foot, and a thousand addresses are copied in a few minutes.

Scholl's Life Boat was constructed on a novel principle. It looks like a great green porpoise, with a lid opening into his back. Look into the interior, however, through the lid, and you discover the arrangements for the accommodation of a crew and passengers—for the saved and the rescuers, as the case may be. The object of the boat is to pass through a heavy surf with safety. The internal fittings of the boat are below the centre of gravity and of flotation. They are hung in the manner of a binnacle compass, that is, be the motion of the external shell or hull of the boat what it may, the persons within are always maintained in a horizontal position. Indeed, let the boat turn round and round like a spindle, which is hardly possible, its passengers are nevertheless unmoved. The steering apparatus is within, and so are all the arrangements for a screw propeller.

Some ingenious small hand-labor saving machines were the most looked after. One of the most curious of these was the machine for milking the four teats of a cow at the same time, and in a manner precisely similar to the action of the calf's mouth upon the teat. Also a very ingenious machine for making paper bags, which turns them out folded, packed, dried, and finished, at the rate of 46 a minute.

A Wringing Machine, of great efficiency and

economy, was shown. Its principle consists simply of two rollers of India rubber, kept at a tight pressure by means of screws, and on turning a handle the articles of clothing, when washed, are drawn between the rollers and pressed dry without the slightest injury to the fabric.

A Caloric Engine, by Wilcox, was shown. It is an engine of low power, quick in its revolutions, not liable to derangement or explosion, and of which the consumption of coal is as low as 100 lbs. per day of 10 hours. Some good folding and revolving drying machines were shown in the American department, the prices of which were as low as 80s., of which 10s. is sent to the Lancashire relief fund. They had a good sale, and the 10s. charitable deodand was regularly acknowledged by the relief committee.

*Sewing Machines.*—It is "now clearly established, that, whatever a needle can accomplish, the machine can do, from the finest and most delicate fabric for female adornment to the heaviest and coarsest habiliments of the sturdy laborer."

There were about thirty different sewing machines in the exhibition, each having, or professing to have, some distinctive peculiarity: in the American court, the Processes court, and in the French court.

Howe's sewing machine is the basis of all successful machines.

**MANUFACTURES.**—*Cotton Fabrics.*—It is greatly to be regretted that the illustration of the cotton manufactures of Great Britain is not more complete. In 1851 it was very indifferent. On this occasion, if not worse in itself, the defect in the exposition is aggravated by a much smaller display in a dependent industry—that of calico printing.

The most extensive series of exhibits in the Cotton Class was that comprised under the head of Sewing Threads.

In the Great Exhibition of 1851 the Turkish bath towel made its first appearance, and in a short time, owing partly to its quick adoption in the royal nursery, the article got into great favor. W. M. Christy and Son, of Fairfield, near Manchester, had an excellent exhibit of these useful adjuncts to the bath. The make is perfect, and the blankets specially noticeable as supplying a great want.

The contributions from Glasgow consisted almost entirely of harness and other muslins, and exhibited a great general advance alike in taste and perfection of manufacture. In cottons, Glasgow keeps as high a place as Paisley does in shawls. Some of the printed cottons were beautiful specimens of printing. The hardness of effect of cotton prints is overcome, or at least diminished, by a very skilful combination of colors, which blend with each other with as much ease and softness of outline as woven fabrics.

R. Owtram and Co., of Watling street, made an admirable display of figured muslins of a

very high quality as regards weaving, design, and finish. The imitation French cambrie, and the jaconots and nainsooks were excellent.

France exhibited largely in this class, and did justice to the power of production, alike in tasteful design, beauty of mechanical result, and brilliancy of color. The finest yarns, and in its way the most complete exhibit, were certainly those of Mallet Brothers, Lille.

The sewing threads exhibited were of first class quality and finish, and the specimens of muslin and lace showed the yarns in their application to these fabrics to great advantage.

M. Thivel-Michon, Tarare, brought together specimens of muslins manufactured from yarn spun by the leading spinners both of the Continent and England. The finest were by the latter, and fabrics were shown made of 220s and 300s spun by Murray and Co.; of 250s by M'Connell and Co.; and of 300s and 440s by T. Houldsworth and Co., all of Manchester. The specimens of muslins made from cotton grown in Algeria were very suggestive, but none seemed to go beyond 180s.

In the French court was a most elegant exposition of tamboured work in net and muslin. M. V. Dubois, Paris, showed some admirably tamboured muslin curtains. The work is done with great ability. The foliage in one example was based on tropical plants, and the effect of some portions was very superb.

The contributions of cotton goods from Switzerland of goods manufactured for exportation say much for the ability and enterprise of the people.

The Belgian contributions in this class were of a very practical character.

Probably the most remarkable exhibit of cotton goods in the Austrian Department, consisted of shawls and other articles of ladies' dress, with neck overties for gentlemen, made of chenille and cotton.

The cotton goods of the Zollverein were cheap and strong clothing for working men. Some of these goods were made with a plush-like face, soft and downy, and, whilst the patterns and dyes are well selected and in excellent taste, the finish is equal to woollens of the same character.

Saxony had some useful exhibits of cotton.

The Milan Chamber of Commerce exhibited a series of useful fabrics in cotton. There was also a curious, but we fear not a very practical illustration of the produce of Italy in raw cotton.

The only exhibitors of cotton goods from the United States were Gardner, Brewer, and Co., of Boston, Mass.

Three prize medals were awarded to exhibitors of raw cotton grown in New South Wales, and the same number to the exhibitors of the same material grown in Queensland.

*Flax and Hemp.*—This important section of textile industry presented few novelties. On the whole, the flax and hemp manufacture proper may be said to have been stationary

since 1851. The manufacture of jute has, however, progressed enormously, and it is stated that 40,000 tons of this material are now worked up annually in Scotland.

The foreign productions in flax and hemp were pretty much on a par with those of 1851.

Among the flax machines exhibited was an improved Power Loom, by Harrison and Sons, Blackburn. It is supplied with a self-acting positive letting-off motion, which delivers the warp as required by the taking-up motion for the cloth, which motion is also positive. These two motions work in concert, and with such precision that the warp is delivered from the yarn beam with the same regularity when the beam is almost empty as when it is full. The taking-up roller of the loom is covered with a patented surfacing material instead of that in ordinary use, made of emery. It is also supplied with the web-stopping motion, and other important appliances. A loom of this description is capable of weaving upward of 180 yards of linen per week.

*Silk and Velvet.*—The English silks made a great show in themselves, and there has been nothing yet displayed by foreigners which equals our best specimens of loom manufacture. Grant and Gask sent some gorgeous specimens of English made silk curtains, where the brocade fabric is interwoven with designs in spun glass, as fine as silk. These *tissues-de-verre* are of a similar manufacture to the hangings that are now in the throne room at St. James's, and which have been some thirty years in use, though still as bright as ever. Fry and Co., and Pim Brothers, exhibited every kind of poplin, either watered, embroidered, or figured. One of the best examples was a copy in white silk of the various forms of snow crystals worked on a blue ground, by which, of course, an almost endless diversity of beautiful little stars is obtained. Of silk, the most important manufacture of France, the finest specimens were from Lyons. In elaborately figured silks, France is unrivalled in the manufacture. M. Schulz set out two pieces of white silk—the one embroidered with orchids, and the other with birds of paradise. The work was a perfect marvel; it was the most astonishing piece of silk in the whole exhibition; and along with it were shown 800 reels of thread of various tints, which had been required for the production of the figures.

The show of ribbons sent by Coventry was magnificent. There are apparently very few ribbons made anywhere in England but at Coventry—certainly none which can compare with them, either for fabric or design.

The most beautiful silk fabric which the French now make, and which is in common use, goes by the name of chiné. They excel all the world in this. The peculiarity of it is, that the pattern, which may display any amount of coloring, is printed on the warp and on the weft alone, and that as a consequence it appears, after the weaving has been completed, with a

vague and misty outline; to produce a good pattern by such means requires the nicest care.

*Woollen and Worsted and Mixed Fabrics.*—In these great and important industries a most decided improvement is manifested in the general taste of the goods and perfection of dye and finish.

On the foreign side, France, Belgium, Austria, Prussia, and Saxony (the two latter as States of the Zollverein) exhibited largely and effectually alike in woollens and mixed fabrics; and marked improvements have taken place in certain directions. France has probably made the most decided improvement in the greater substantiality of her woollen cloths; in shawls and the more ornate mixed fabrics, her pre-eminence in certain points remained much the same.

*Carpet Manufacture.*—In carpets the exhibition is well represented, but there is but little novelty either in design or manufacture.

*Tapestries of Gobelins and Beauvais.*—The tapestries of the imperial manufactory of Gobelins and of the sister institution of Beauvais at this very day are as highly prized as when the royal works were first established two centuries since. Their exhibit consisted of four tapestries and two carpets—the large central tapestry containing a full-length portrait figure, and the two carpets are from the parent institution (Gobelins), and the fruit pieces to the right and left from Beauvais.

The tapestries from Beauvais were in no way inferior to those of Gobelins; yet they differ so widely in character that a mere glance will suffice for the distinguishing between the works of the two manufactories. Those from Beauvais are of still life and fruit, while those from Gobelins are of an historical character.

Kamptulicon was exhibited by Taylor & Co., and is a floor cloth made of cork and India rubber. It is admirably adapted for all situations where the floor is damp, being exceedingly durable.

*Printed and Dyed Fabrics.*—Probably in no department of the whole exhibition has there been so thorough a change since 1851 as in that of printed fabrics: mousselines-de-laine, barèges, and other printed fabrics of kindred make having been superseded by alpacas, mohairs, and various light and elegant mixed fabrics. Nevertheless, the leading printers, both of Manchester and Glasgow, contributed little to the display. In the matter of design the great body of English and Scotch calico printers are pretty much where they were fifteen years ago.

The French printers made a great effort to completely illustrate everything they were doing, especially in the way of improvements in printed fabrics: the result was, they made a valuable display, and deservedly carried off the largest portion of the honors.

A systematic illustration of the various improvements in the chemistry of calico printing and dyeing since 1851 was given by Mr. Rum-

ney. All the new dyes and chemicals of any importance introduced into the trade during the last eleven years were here shown, as illustrating "the latest chapter in the history of calico printing." The various dyes and chemicals were exhibited in bottles; and the examples in cotton, silk, wool, and mixed fabrics were also shown. Amongst them was the application of Mr. Perkin's discovery of coal tar and its remarkable product aniline as a coloring agent. Aniline colors were shown in their varied forms of dyeing and printing as applied to cottons, cotton velvets, silk, and woollen, in shades of purple, reds, and blues, known as mauve, magenta, &c. The colors in silk were especially brilliant. There were also illustrations of murexide colors on cotton and woollens. Murexide, generally called Roman purple, was in great vogue amongst printers and dyers about 1856. This is a guano color, as the uric, and is found in sufficient quantities in that substance, which is first treated with hydrochloric acid, and subsequently with nitric acid. The final result was seen in the specimens exhibited. To these were added pigment colors fixed with glue and mercury, under Lightfoot's patent; also aniline and pigment colors. Pigment colors fixed by albumen and substitutes for albumen, such as lacterine, gluten, &c., were shown; and coal-tar colors in combination at one operation with dyeing and printing. Specimens of emeraldine, a new green, and azurine, a new blue, were contributed by Mr. Orace Calvert, F.R.S., of Manchester. Emeraldine is produced by preparing cotton with chlorate of potash; then printing with an acid chloride of aniline, in a given period a bright green appears; next the green is subjected to the action of a solution of bichromate of potash, and the tint is changed to a deep blue, which has been called azurine.

Furniture chintz printing, represented by two exhibitors, stood where it did in 1851; the printed table covers were as stationary. Of printed felts there were better specimens.

In dyeing, pure and simple, a great triumph has been achieved by English dyers on this occasion.

France exhibited largely, and did justice to the power of production alike in tasteful design, beauty of mechanical result, and brilliancy of color. Austria made a great advance; but the most remarkable progress was that of Russia, for, notwithstanding the disastrous war and political distractions since 1851, Russia produced in this Exhibition most remarkable specimens, probably the best of the kind shown, considering that eleven years ago the industry may be said not to have existed.

A beautiful combination of science and mechanics as applied to the art of engraving was shown in the electrograph engraving machine of Mr. Henry Garside, of Manchester. This is intended for the engraving of copper cylinders used in calico printing, and may be described here. The distinctive feature of this apparatus,

apart from its mechanical arrangement, consists in the application of voltaic electricity in communicating movement to important and delicate portions of the machine. The cylinder to be engraved is first coated with a thin film of varnish, sufficiently resistant to the continuous action of the strongest acids. The required number of copies of the original design are then traced on the cylinder by means of a series of diamond points arranged on the machine, in a line parallel to the cylinder. The metallic surface of the latter thus becomes exposed at the parts required to be engraved. A bath of nitric or some other potent acid is afterward used to deepen the exposed portions to the extent required, and thus the operation is completed. The diamond points are all in connection with as many small magnets, and these are so arranged that intermittent voltaic currents are established in unison with the original design. The results are that the diamonds are withdrawn or advanced at the proper moment, and the tracery forms an exact counterpart of the copy. There are, also, adjustments, which enable the operator to enlarge or diminish at will the size of the patterns to be engraved.

*Lace Making.*—The respective positions of the countries which may be said to compete in the lace manufacture have, we think, continued unchanged since the last Exhibition. England has made a wonderful advance. France well supports its ancient reputation; but, undeniably, Belgium has contributed the most exquisite specimens.

In the Belgian Department M. Hoorickx exhibited a beautiful novelty—a handkerchief which presents every variety of point stitch, and several styles of design. At the extreme edge of the lace border is a wreath of convolvulus leaves and flowers; within that is a kind of arabesque pattern enriched with *plumetis* or satin-stitch, which is quite a new feature of the Belgian laces; and then comes the triumph of art in a border of exquisite little bouquets; the miniature flowers are all in relief, the rose showing its circling petals, and other blossoms their natural forms. The small centre of cambric is enclosed within a mechanical design of heavier substance. The price is about £200. A section of flounce, half a yard wide, with flowers in the same style of relief, was also displayed: the value of the set of two, £800; that of a tunic with berthe and handkerchief, about the same. Van Rossum showed point sets of handkerchief, lappet, collar, and sleeves: each set is worth £240, and occupied four years in making.

The French have much improved the "guipure," called by them "Maltese." Among various shawls and frounces of Chantilly was M. Seguin's half shawl, valued at £140, pattern, a Chinese garden. The Compagnie des Indes showed a point d'Alençon flounce, priced at £1,000.

The exhibition of British lace was admirable, not only for its beauty and richness, but for the



variety of object in which Honiton, Ireland, and Nottingham compete for supremacy. The larger kinds of lacework, as curtains, &c., came almost entirely from Nottingham: the honors were carried off by the exquisite designs of Copestake and Moore. The Nottingham imitations included Spanish shawls and mantillas, and black Chantilly, remarkably improved. Reckless and Hickling, of Nottingham, exhibited laces, frouces, tunics, mantles, shawls, coiffures, and barbes in one piece, all made by the pusher machine, with the application of the jacquard; all the fabric pattern being made by the machine, and the outline being entirely needlework. These goods nearly rival the hand-made laces of Cambray, Chantilly, and Bayeux.

A case of Spanish blondes contained articles richly embroidered in colors and gold thread; the real gem of the collection, however, was a white mantilla—the pattern, wreaths of flowers supported by flying cupids, of solid texture; the ground light guipure. Saxony is remarkable rather for the low price than the quality of its laces; but Berlin added to the attractions of the Exhibition a very creditable suit of Brussels point on real ground.

*Furs, Feathers, and Hair.*—The finest specimens of this class were grouped or displayed in trophies. Messrs. George Smith & Son, Watling street, displayed, in this form, various descriptions of sable, and eight varieties of fox; and beneath these, magnificent paletots, with smaller articles intermixed. The most striking feature of the group was a mantle of pure white ermine, without the usual intermixture of tails, but trimmed with a broad border of delicately-marked chinchilla. The handsome trophy of Mr. Nicholay, the court furrier, formed one of the most attractive ornaments of the nave. Here the Russian sable was to be seen in perfection: a complete set of it, including trimmed velvet mantle, is valued at £500. Among the treasures of the collection was a sea-otter skin, worth £50.

De Costa, Andrade, & Co. displayed an ostrich feather trophy, in which as many as ten different colors of tints were presented in one single feather. The white plumes were examples of purity of color and excellence of finish; they were selected from 5,000.

Among other curiosities exhibited was a case containing specimens of human hair of great length, shorn from the heads of English, German, French, and Italian ladies—hair of every hue, from pale auburn to jet black, and of every degree of fineness and silky gloss. The honors in this class, however, were carried off by some fair unknown of Great Britain, from whose head had been severed a lock of jet-black hair, no less than 74 inches in length!

*India Rubber Manufactures.*—There were upward of twenty exhibitors of various manufactures in this material, besides those of gutta-percha, and other analogous substances.

Prominent amongst these were the original

patentees in England, O. Mackintosh & Co., of Manchester, who exhibited beautiful specimens of the raw material, showing the process of manufacture, from the masticated lump to the finished sheet. In soft vulcanized India rubber was shown a door mat, produced by making incisions with a sharp knife at regular intervals, which being kept open, during vulcanization, a mat is produced, firm to the foot.

Warne & Co. showed their novel junction rubber for piston rings and pump buckets, made of soft and hard rubber combined; and their screw-shaft water-stop for ocean steamers, which prevents the necessity of stoppage for repacking when at sea. This is effected by the inflation of two rings so arranged as to answer the end required whilst the stuffing box is being repacked. They also showed an elastic bath towel, having a rubber warp alternate with cotton.

The North British Company, of Edinburgh, excelled particularly in their overshoes. They showed, let into the floor, the largest valve which has ever been made, being six feet by four inches in diameter, and one and a half inches thick, made of pure rubber, in the manufacture of which no solvent had been used.

Walton & Co., of Chiswick, showed samples of their "campticon, or India-rubber substitute," made from oxidized oil, freed of unctuous matter, and formed into semielastic resin, which, for steam packing, driving bands, and hose, answers as well as India rubber, and at a considerably less cost.

Perreux's method of constructing pump valves, is copied from the valves contained in the human heart. The valves are made of India rubber vulcanized for the purpose; they are of the form of a tube flattened at one extremity, similar to the mouthpiece of a hautboy. The thickness of the sides of the upper part diminishes gradually to the top, where the two sides meet and form two lips, which, when the valve is in a state of rest, are in close contact, and prevent the downward passage of the fluid. With any upward pressure the lips freely separate, and allow of the upward passage of the fluid; the gradual diminution in the thickness or tapering of the sides forming the lips of the passage enables the valve to open and close with the slightest variation of pressure. The passage for the fluid through these valves is larger than in any others of the same dimensions; they also possess the advantage of having a "clearway," there being nothing whatever to retard the flow of water; and, owing to the self-acting principle imparted by the elasticity of the material, they close perfectly and instantaneously the moment the pressure from below ceases. The lips of the valves being flexible and elastic, any foreign substance which may enter the suction pipe, such as sand, gravel, coal dust, cinders, grain, cotton, tow, rags, chips of wood, &c., passes freely through, without in the least interfering with or deranging the action of the

valve; semifluid material, as tar, passes freely through. Should a pump of this description remain dry for any length of time it requires no priming by pouring water into it, as other pumps do, but is always ready for immediate use. In practice these valves answer exceedingly well; they are extensively used in soap and alkali factories, and by paper makers, tanners, bleachers, and dyers, in pumping paper stuff, chemicals, tan liquor, &c., The pumps exhibited had glass cylinders or barrels, so that the action of the valves might be seen. It is found advantageous to use glass barrels, as they are free from corrosion, and lubricate themselves with the material which is pumped through them.

*Leather, Including Saddlery and Harness.*—Additional warranty was given to the old fable of "nothing like leather" by the contents of a small court of British specimens, remarkable both for material and manufacture.

From the headquarters, Bermondsey, Hepburn & Son sent an enormous butt-hide of black enamelled leather, 11 feet long by 10 feet 8; and a large number of tanned English sole butts, the average weight being 43 lbs.; the thickness and texture being very remarkable. Samples of all the tanning materials used in England were shown in front of these butt-hides—English oak bark, valonia, gambier, shumac, mimosa, hemlock, oak bark, and others. Leather for boot tops, thin and light in texture as a lady's glove, for jockey boots, contrasted strongly with the enormous thickness of the leather made from the walrus hide. There was also buff leather for soldiers' accoutrements. In saddlery and harness, Mr. Cuff showed a magnificently embroidered military state saddle, the property of the Duke of Buccleuch; it is covered with blue velvet, richly worked in silver and gold, and is a gorgeous piece of work, rivaling some of the state trappings of India. Merry, of St. James's street, sent a beautiful saddle and suite of harness, made to the order of the Prince of Wales. The whips, by Swaine & Adeney, formed a brilliant and tasteful display, a case of theirs being valued at more than a thousand pounds. Among other applications of leather were specimens of that once fashionable accomplishment for ladies, potichomanie, snuff boxes, and embossed leather for walls, screens, and covering furniture.

*Paper Making and Stationery.*—The French paper makers made a far more satisfactory appearance than the British; and any one, after a stroll through their court, could form a very fair judgment concerning the peculiarities and excellences of French paper. In France linen rags appear to take the place of cotton in England, and the average quality of the papers is, therefore, higher. In the commoner kinds of printing papers, such as are used for our newspapers, France cannot compete with England. Very cheap French papers seem to be produced by a free admixture of clay, and they drop apart under tension, like tinder. These

printing papers are generally unsized, one advantage of which is, that the paper takes the impress of the type with greater perfection. In their writing papers they mix their size with the pulp, whilst we commonly spread it on the surface, and often by this skilful glaze a poor paper is passed off for a good. In fancy writing papers we know nothing in England to compare with the French delicacy of tint and finish; and there were colored note papers with a variety of ornamental water marks. French writing paper, if sufficiently known, would, like French gloves, have many purchasers. It is easily written on, is light, and finely finished. For foreign letters there is nothing to compare with the thin French paper. We noticed some foolscap, light as tissue paper, weighing only six pounds to the ream, and which can be written on both sides.

There was also some paper made from the hop bine, by Barling, amidst the hop grounds of Kent; and some board made of paper, of which the exhibitor, Mr. Towle, more than twenty years ago, built himself a house, which has once, at least, successfully resisted a fire, that burned to the ground the adjoining substantially brick-built residence. The application of silicate of zopissa, a description of Arabian gum, to paper, by Mr. F. Szerelmy, has been found to give it so much strength that the material may be used for rocket tubes, planking for ships' sides, water pipes, and, it is even said, for heavy artillery.

Burgess & Ward, of Mendip Paper Mills, near Wells, showed excellent specimens of straw paper, with samples illustrating the various processes of its manufacture and application. These makers claim for their paper superiority over that made of common rags, and to prove its capabilities showed its adaptability for newspapers, railway time tables, placards, &c. They also exhibited book work, music, fine engravings, and lithographs, printed on their papers; also paper hangings, enamelled papers in various hues, fancy box papers, in gold colors; and a delicate polychromic printing, executed on their paper by Day & Son. All these specimens showed good surface and texture; proving that the richest work tells upon straw paper as well as on the finest rags; and Ward's paper has less of the objectionable brittleness than any other straw paper.

A very interesting collection of the products made from the leaves of the maize plant was shown; they included a nutritive bread stuff; a fibrous material to be spun or woven like flax; and a pulp from which a most beautiful paper can be made. The latter process, as carried on in the Imperial Paper Manufactory at Schloegelmuehle, Lower Austria, gives a produce of 100 lbs. of paper from 300 lbs. to 350 lbs. of head leaves, irrespective of the other materials. And, what is important in this new material, it is very abundant; for, according to official accounts, the maize planted in Austria yields, annually, head leaves estimated at 2,750,000

cwt., which, worked up into paper, would exceed 1,500,000 lbs. So strong and durable is maize paper that, if ground short, it can be used as an excellent substitute for glass, so great is its natural transparency and firmness.

*Printing.*—Plate, lithograph, and other modes of printing were well illustrated. In this class were exhibited specimens of printing type. For good, clear-cast, and durable type England has a high reputation; but, in the decorative parts of the art, ranks low in the cultivated judgment of her Continental neighbors. None of our printers' ornaments will stand comparison with those put forth in the exquisite pattern books of Paris and Vienna.

Probably the most curious feature of this department was the collection of Trübner & Co., of Paternoster-row, consisting of their Russian publications. From information supplied, it appears that the Russian press, the first ever introduced into that country, was established in 1858; and so signal seems to have been its success that it boasts now of more than fifty original works, which have exercised an enormous influence on the development of Russian affairs. The works hitherto produced are of a political, historical, literary, and theological character. We remark among them the first volume of a Russian Bible, containing the complete Pentateuch. It should be remembered that the Russian church never allowed the Bible to be translated into the vernacular, and all honor is, therefore, due to Mr. Trübner for having been the first to do what one would have thought to be the peculiar province of the British and Foreign Bible Society. The books are all very creditably got up, paper and printing being very excellent,—indeed, it is reported that London Russian type has become the model from which modern native Russian fonts are being cast.

Among the writing inks was Blackwood's Jesoline, the color of which, being held in solution, never deposits, and the ink, therefore, does not get thick.

Black-lead and Colored Pencils were exhibited. Melville's solid Red Ink deserves notice, so also Messrs. Wolff's Colored Crayons in cedar; and in the foreign courts were to be seen how far the pencil manufacture can be carried, and at what prices the pencils may be obtained. Grossberger & Kurz, of Nuremberg, manufacture pencils the full length, which they sell at the very low rate of 1s. 1d. the gross.

In Steel Pens English manufacturers reigned supreme.

Reynolds & Sons, Vere-street, have contrived some Playing Cards for the use of the blind; the pips being cut out and mounted on ordinary cards, so as to stand out in relief.

To the assemblage of choice examples of color printing, Leighton Brothers, of Milford house, Strand, contributed a collection of their Chromatic Prints, such as are occasionally given away with the numbers of the "Illustrated London News." Of some of these

prints as many as 280,000 copies have been printed.

In printing surfaces the Electro-Block Company showed their most ingenious process of enlarging and reducing blocks. This, with Mr. W. J. Linton's kerographic process and Mr. Wallis's new art of auto-typography, illustrated one among the very many attempts to effect that long-sought desideratum—an effective metallic relief produced without engraving. Bradbury & Wilkinson exhibited minute engravings for the prevention of forgeries in notes; and the exquisite specimens of the nature-printed books produced by the late Henry Bradbury were also shown—an honor to any country.

The specimens of lithographs and chromolithographs shown by Day & Sons, Rowney, Vincent, & Hanhart were among the finest that have ever been displayed. It is difficult even for the most practised eye to detect the difference between some of the best specimens of these and carefully finished water colors.

*Bookbinding.*—Leighton, Son, and Hodge's work displayed most artistic skill combined with some special excellences: amongst the items most noteworthy, were "The Sermon on the Mount," the largest block ever engraved or worked in gold in one piece. The arming press by which the impression was made, is the most powerful in the world: it weighs upward of ten tons. This firm was the first to introduce for the ornamentation and lettering of books, aluminium.

In matters of taste and delicacy of manipulation, the French are in advance of us; as exemplified in M. Engelmann's large volume bound in red morocco, inlaid with dark green; and a square volume in green morocco, inlaid with small dice of orange and yellow. In claspings, the French likewise excel. MM. Maine and Son, of Tours, showed a copy of "La Touraine," unique, and one of the most beautiful vellum books in the world; the plates are like sheets of ivory; binding, morocco, inlaid.

*Educational Works and Appliances.*—It was judiciously intended by the Committee to whom the Educational Department of the Exhibition was intrusted that the contributions to it sent by the various countries should be in juxtaposition; to insure their being seen and compared with greater facility. But the Foreign Commissioners determined upon keeping each educational collection separate; nevertheless, we shall describe the more noteworthy objects of the several collections in one group.

The British Educational Collection was not very extensive; the books exhibited were numerous and well chosen; some eminent publishers sent their most approved Educational Works. The various well-known educational institutions showed what they have done in providing books and requisites of a useful and convenient description. There were books for the blind, and untearable books for children; excellent maps, and a projection of the two hemispheres, representing the globular form

of the earth in such a way as to prevent or remove the usual crude ideas of young persons on the point. Of the many good globes which were exhibited, that of Macintosh, made of India rubber, seemed to be the most convenient; when not inflated it occupies very little space.

The Austrian Educational Collection was attractive; the Government priding itself on having directed education, in a special manner, to practical purposes, the country being well provided with schools of every kind and for every class. Among the requisites for teaching shown by Austria was means of instruction in shorthand, a branch not often considered as belonging to ordinary education. We found maps printed, not on paper, but on woven fabrics, and hence more convenient and durable than the ordinary kind; also aids in the way of rendering formal lessons unnecessary; Pictures and other objects for the instructive occupation of youth; Models of Schools, &c. A variety of Mechanical and other Toys was shown.\* The models and apparatus connected with realistic schools, or those affording, in addition to ordinary instruction, facilities for acquiring special branches of knowledge relating to manufacturing and trading pursuits, were very interesting. Philosophical apparatus used in the higher grades of instruction was also shown; and illustrations to anatomy and comparative anatomy.

Belgium had objects devoted to the school of industry, besides ordinary apparatus, such as books, models of school desks, &c.; a collection of substances used for domestic purposes; historical and mechanical diagrams; designs for shawls, &c., some of them extremely beautiful; and specimens of the work done by the pupils. In a Belgian school museum were diagrams and other illustrations of natural history; collections of minerals and philosophical instruments; specimens of the works of the blind, and of deaf mutes, &c.

France had arranged her educational contributions in a very pleasing and convenient way, in two compartments: the first devoted to the means and appliances for instruction; the second, to the results obtained from them in the shape of works executed by the pupils. In the former, besides an excellent collection of books connected with pedagogy, globes, maps, &c., was an Orrery, placed within a sphere of glass, having the fixed stars depicted upon it. There were also models of solids and curves, photographic copies from antique busts, anatomical and mechanical diagrams, natural history and botanical collections, &c. In the compartment which contained the works of the pupils, was a painting on porcelain, by a young workman only eighteen years old; and some beautiful specimens of flower painting, sent by the School of Design of the city of Paris. The

\* The trade in toys in Austria is very great. The Gröden Valley, in the Tyrol, exports annually three hundred tons of wooden toys, that reach every quarter of the globe.

work executed by the blind, and by deaf mutes, was very striking.

The Educational Collection of Italy included some good diagrams; models of crystals and solids; a collection of chemical substances; a small museum of economic botany, containing the various agricultural products of the country, mineralogical and natural history specimens, &c.

Prussia, long distinguished for her exertions in the cause of education, among her educational apparatus exhibited some good Maps and Globes, both plain and in relief; apparatus for teaching the rudiments of geometry by superposition of the surfaces, or parts of surfaces, which are to be proved equal; some very excellent elementary collections of minerals, &c.

The Educational contributions of Russia included models of animals and fruits, and representations of the different varieties of the human race. Switzerland had done little to show the progress which she has really made in education. Her contribution was nearly confined to a few neat mechanical diagrams, collections of common substances, objects relating to natural history, and herbaria.

*Furniture and Upholstery.*—There was a large show of excellent furniture, which not only impressed one with its sumptuousness and magnificence, but also with its bold and elaborate beauty of design, its art-workmanship and high finish. And in no class of the Exhibition were there better proofs of the advancement of the national taste since 1851 than in the furniture display. Some of the fine forms reminded one of the furniture artists of last century, when the cabinetmaker was an artist as well as an artisan. Our success in this branch assures us that we need no longer ransack old mansions, or curiosity shops, for furniture of beautiful design as well as craft, when it is so readily produced by the workers of our own day.

All our great firms competed here, and the result of their combined efforts was an exhibition which defied comparison with that put forward by any other country. The Sideboard Bookcase, inlaid with Wedgwood plaques, and the Robinson Crusoe Sideboard—the former for exquisite and most harmonious decoration, and the latter for its spirited carved work, were among the most successful specimens in this court.

There were shown here some clever illustrations of how far machinery can be employed instead of hand work in carving; in this subdivision of labor, the mechanical stage is likely to be carried so far as to reduce to the minimum the life, feeling, and finish of hand labor.

*IRON MANUFACTURES.*—*Yield of Cast Iron.*—Great progress has of late been made in this respect. In the Great Exhibition of 1851 there was a model of a blast furnace from the Owm Celyn Works, Monmouthshire, which yielded a weekly average of 209 tons of white pig iron during twelve consecutive months. This was

regarded as a very large amount. The gradual increase in yield in different districts is certainly one of the most interesting points connected with the development of the iron trade in modern times. Not many years ago, a weekly return of 70 tons was considered good, but now a single furnace has yielded the enormous amount of 600 tons in a single week. Some of the Aberdare furnaces are reported to have done excellent work, and to have yielded a weekly average of 400 tons. This has been effected by what is called "driving hard"—*i.e.*, sending a large quantity of blast through the furnace in a given time. Great yields have recently been obtained at the Barrow-in-Furness works, Cumberland. These works are quite of recent construction, and were represented by a costly mahogany model, occupying a very large superficial area. There was also a single model, made to open, of one of the furnaces. The average yield in one of these furnaces per day during the fortnight ending the 16th of April, 1862, was 91 tons 7 cwt. 8 qrs., or the enormous amount of about 640 tons (short weight) in a week of seven days. In one week this furnace yielded not less than 684 tons (short weight)! The qualities of the pig iron were 8.5 between Nos. 1 and 4, and 2.5 between Nos. 5 and 6, inclusive of 35 tons of mottled pig. It is exclusively rich red ore that is smelted at these furnaces, and the fuel is Durham coke. Gases are economized in raising steam, and their propulsion to a distance is aided by the exhaustion of a fan.

In the Austrian Department Charcoal Pig iron was shown; it is produced with a consumption of less charcoal than is known in any other locality. The ore is brown decomposed spathose ore, containing, when roasted, 52 per cent. of iron, and the products are gray iron and spiegeleisen. Only 60 parts by weight of charcoal are required to produce 100 of pig iron. Models of furnaces for smelting iron and copper were found in the Russian Department. They are long and rectangular in horizontal section, and are provided with numerous twyers. One of those furnaces is reported to have been in operation for smelting iron during a year and a half. A large yield and reduction in the amount of fuel are stated to be the advantages of this kind of furnace.

*Forged Iron.*—Some of these specimens were interesting as illustrations of remarkable malleability, others as displaying skilful workmanship, and others on account of their large dimensions. With regard to forgings remarkable on account of their large dimensions, the two objects which stood out preeminently were the enormous Crank Shaft and the large Armor Plate manufactured by the Mersey Steel and Iron Company. The monster shaft weighs about 25 tons, and is destined for one of her Majesty's ships. During the process of forging, this heavy mass was moved by powerful and skilful mechanical appliances, with ease and rapidity, just as a blacksmith handles his iron.

The plate bears the following inscription:— "This Armor Plate, 21ft. 3in. long, 6 ft. 3 in. wide, 5½ in. thick, having a superficial area of 183 feet, weighing upward of 13 tons, was forged at the Mersey Steel and Iron Works, Liverpool, and has been neither smithed nor tooled since it left the steam hammer. This plate would have been made 15 ft. to 20 ft. longer if space could have been obtained." It is an admirable specimen of forging. The great Horsfall Gun, of which every one has heard, is another testimony to Mr. Clay's (the manager of the company) skill in forging large masses of iron. This gun was made several years ago: it is 10 in. in the bore, and has stood charges of 80 lb. of powder.

*Welding.*—The Exhibition contained many very interesting illustrations of Welding under difficult conditions. The Butterley Company's large girders, of which one was in the form of a double T, 12 in. across each end and 3 ft. deep, was welded longitudinally. In the English Department was shown a stamped, solid, wrought-iron wheel, made by an ingenious process invented by M. Arbel, a Frenchman: it was forged under the steam hammer, and combines strength and cheapness. In illustration of the successful welding of steel and iron in railway tire bars, we may refer to the specimens of the Monkbridge Company's collection. The iron tire being heated to whiteness, and dusted over with borax powder, the melted steel is cast round it: the union seems to be perfect, and we have examined specimens which have been hammered out into thin plate without presenting any sign of separation. This process is also the invention of a Frenchman, and promises well.

The French appear to have made great progress in the manufacture of iron, and we are indebted to them for many ingenious mechanical contrivances. Two instances in the case of railway wheels have just been mentioned, and to these might be added a third—the process of Pétin, Gaudet, and Co., of making "weldless tires," of which the Blaenavon Company exhibited specimens manufactured by themselves.

*Rolled Iron.*—Specimens of Boiler Plate were shown, doubled hot and doubled cold, and punched under various trying conditions. The Butterley Company exhibited a Rolled Boiler Plate, 12 ft. 9 in. long, 7 ft. 6 in. wide, and 1½ in. thick. The solid-rolled Engine Beam Slab well deserved attention: it is 31 ft. 6 in. long, 7 ft. wide in the middle, 2½ in. thick, has a superficial area of 163 square feet, and weighs 7 tons.

*Sheet Iron.*—Of sheet iron there were numerous fine illustrations. The Belgian sheets were, of their kind, unrivalled, and were specially characterized by their smooth and dark bluish gray glossy surface. The color is obviously due to a thin and firmly adherent skin of oxide of iron, which has been detached here and there near the edges of several of the

sheets, clearly revealing the color of the subjacent iron. Russia still continues without a competitor in the production of a peculiar description of sheet iron, which has long been highly esteemed in commerce. The quality of the iron, which is both smelted and worked with charcoal throughout, is excellent, and the dark polish on the surface is remarkable. Austria exhibited excellent sheet iron, and so did the Zollverein, except the specimens of the so-called transparent iron, which are a sham. This iron is not transparent at all, but is perforated with innumerable small holes through which light passes, thus showing how inferior in malleability iron is to gold.

*Bars, Rails, and Girders.*—This display was magnificent; and in no branch of the metallurgy of iron has greater progress been made since the first Exhibition of 1851. The mill power required to produce some of these articles is enormous, but we are probably far from having reached the maximum limit. There were gigantic rails exceeding 100 ft. in length, but these were to be regarded as curiosities, interesting as exhibitions of power and effective mechanical appliances, showing what might be done if required. In general they were admirable specimens of rolling. The Butterley Company sent a Rail 117 ft. long, and 5½ in. deep, and a Tension Bar for Girders, 83 ft. long, 1 ft. wide, and 1 in. thick. The Dowlais Company exhibited two rails of the following dimensions: one 53 ft. 6 in. long, 4½ in. across the head, and 10 in. deep, the other 31 ft. 6 in. long, 5½ in. across the head, and 15 in. deep. In the Zollverein was a section of rolled rail 5½ in. across the head, and 18½ in. deep. Belgium made a very creditable show of rails and rail sections; and it is declared that in certain foreign markets she has beaten the English producer of rails, both with respect to quality and price. The Austrian Society of State Railways exhibited specimens of rails—some with the head of granular and the foot of fibrous iron, and others of puddled steel.

Dupont and Dreyfus (France) exhibited a fine and extensive collection of objects of interest, especially with reference to building constructions. There were flat bars and girders in great variety and profusion, indicating excellent workmanship. In France iron is extensively used for building purposes, and is applied with much science.

The Bridge-links for Suspension Bridges manufactured by Howard, Ravenhill and Co., Rotherhithe, were interesting as having been made by rolling. One of the links exhibited weighed 6½ cwt. From the time the slab left the furnace to the complete formation of a large link about four minutes elapsed.

*Armor Plates.*—There were no metallurgical illustrations in the Exhibition of more interest than the rolled Armor Plates for ships. Of these two were sent by John Brown and Co., Atlas Works, Sheffield. The immediate dimensions are as follows:—(No. 1) length 21 ft.

8 in., width 4 ft. 2 in., thickness 6½ in., weight 10 tons 12 cwt.; (No. 2) length 24 ft., width 3 ft. 8 in., thickness 5 in., weight 7 tons 17 cwt. A few years ago the rolling of such enormous masses of iron would have seemed incredible. Brown and Co. also exhibited large, but much thinner plates outside the building in Exhibition-road; one was intended for gunboats, and is 22 ft. long, 7 ft. 2 in. wide, and 2 in. thick; and the other for engine beams. These two plates were thus manufactured. The metal consisted of "best new scrap," obtained from a mixture of Swedish, Shropshire, and Derbyshire refined iron. It was balled under a 4-ton steam hammer, piled under a 6-ton helve, and rolled into bar, re-rolled into slabs, all crossed, then rolled into "moulds," and lastly, rolled into the finished plates. There are 860 layers in the 6½-inch plate.

The Butterley Company sent two Armor Plates, each 14 ft. long, 5 ft. wide, and 4½ in. thick, and weighing when finished six tons. The expense of manipulating such enormous masses of iron as these armor plates is necessarily very great; and the present cost of them to the nation ranges between £35 and £45 per ton!

*Canadian Iron.*—Enormous deposits of magnetic iron ore—which, when pure, is the richest of all the ores of iron—have been discovered by Sir William Logan in the Laurentian rocks, which present no traces of organic remains, and are the oldest sedimentary series in the world. The ore occurs interstratified with the rocks containing it. The accumulation of this ore in some localities is so great as to appear incredible. Thus, one bed is not less than 500 feet thick! On the Rideau Canal there is another bed 200 feet thick, which is now worked at Newborough, and from which the ore is conveyed to Kingston on Lake Ontario. Canada also possesses extensive tracts of bog-iron ore on the north side of the St. Lawrence. Cast iron from ordinary bog-iron ore is about the last kind of metal many founders would dream of employing for such a purpose; yet in the Canadian Department was exhibited a pair of Railway Wheels which have travelled, without showing much evidence of wear, not less than 150,000 miles, or about six times round the earth. And it should be remembered that in Canada there are great alternations of temperature, the heat of summer being intense, and the cold of winter extremely bitter.

*Iron in India.*—There was an interesting series of specimens shown in the Indian department. Iron ores, chiefly earthy-brown hæmatite and magnetic ironsand, occur abundantly in several parts of India, and have been smelted, from time immemorial, by the natives in small furnaces. The East Indian Iron Company sent an instructive collection of Iron Ores and the various products which they yield. There are several blast furnaces in India on the European model, using charcoal as fuel. It is a remarkable fact, that in one locality in the

Nerbudda Valley, good Bar iron, but only in small pieces, can be made and sold by the native smelters under 5*l.* per ton.

*Swedish Boat Plates.*—Sweden's chief ore is magnetic oxide, of which fine and characteristic specimens from various localities were exhibited. An instructive series of the far-famed Dannemora ores and the associated rocks specially deserved attention. The ores from this locality are among the finest in the world: and the iron which they yield always commands a high price, on account of its producing good steel. The Swedish iron ores differ much in quality, even when in appearance they closely resemble each other.

One of the remarkable objects shown was the fore part of an iron paddle steamer, 200 feet long and of 120 horse power, which, during a fog in September, 1860, and while going at the rate of eight or nine knots an hour, struck on a rock. The iron was "crumpled up like a piece of brown paper," and yet the vessel got off and proceeded without difficulty to Stockholm, about 100 miles distant. The plates were made and the vessel was built at the Motala Iron Works.

*GALVANIZED METALS.*—Amongst the exhibitors of Galvanized Metals were Morewood and Co., who say that their materials are more durable than zinc. They may be applied in the form of tiles, which are 3 feet by 2 feet, and are curled at the edges to finish as rolls, and are stiffened by transverse grooves. They are also made in sheets of 500 feet and upward in length: thus they can be laid with great expedition by any laborer who can use a hammer; whilst considering that boarding is not required, the cost, say the patentees, is less than asphalted felt. Amongst the other productions of the same manufacturers, were welded-iron water and gas tubes.

With galvanized corrugated iron Morton and Co. can cover an area of 100 feet square (plates and uprights only, furnished them) in five spans, for £370. They can provide and erect an iron cottage with five rooms and entrance porch for £120.

For Zinc Roofing, the *Vielle Montagne* Company, and their manufacturing agents, F. Braby & Co., were exhibitors. Zinc is now constantly employed in Paris, for buildings much larger in scale, and more substantial in construction, than the London houses.

Wolston's Torbay Iron Paints for coating materials which are to be under water, or in a position to be affected by damp, are manufactured at Brixham, Davenport, and are successfully used in dockyards and public works. A caisson in Woolwich Dockyard, painted nine years since, is in a perfectly sound condition, both under water and between wind and water. It is also said that the Torbay paints have been found to stop corrosion that has set in.

Webster and Horsfall exhibited a case of Iron Wires, including music, needles, and flat spring wires, the latter manufactured from the

patent steel wire, which was also shown; with samples of submarine telegraph cables, coal-pit ropes, and ropes for ships' rigging. There were shown two coils of Steel Wire without a weld, of the extraordinary weight of 1 cwt., said to be the heaviest coil ever manufactured. The whole power of a 100-horse engine was required to roll it, and Webster and Horsfall's mill is the only mill in the country at which it could be made. This wire is to be used for pit-guides, in lieu of the ordinary iron guides, liable to frequent breakage at the welds.

Smith and Co. sent from Halifax a bloom, or piece of the best Swedish iron, and specimens of all the stages of manufacture from it down to the smallest sizes of wire. The first stages down to the rod gauging No. 2 or 4, are manufactured while the iron is hot; after that the iron is drawn cold through steel plates similar to the small model exhibited, with some sizes of wire in it; and as the process of drawing hardens the wire, it has to be annealed or softened at various stages, and then drawn again. The above piece of bloom, measuring only 8½ inches long and 8 inches square, and weighing 20 lbs., would, if drawn as small as the finest wires exhibited in the same case, measure 110 miles in length. They will give you 1,000 feet of wire out of a brass farthing; 70,000 feet of wire, or a sheet of brass, 12 feet square, that will not exceed one pound in weight.

*The Hereford Screen*, made by the Skidmore Art Company, at Coventry, for Hereford Cathedral, is probably the finest piece of modern metal work in existence. It has been executed from Mr. Scott's designs since January, 1862; it is much larger in its dimensions than its companion at Lichfield, and, indeed, is the largest piece of architectural metal work ever executed. Iron is of course the principal material used, though in the decorative details copper and brass are largely introduced. In these combinations the fine examples which the early metal workers have transmitted to our time are studied with conscientious care, so as to adhere to the lessons of the past in a work that in itself is perfectly original. Thus, in the Hereford screen we find the iron wrought both into true grilles, and also elaborated after the manner of the early chasers into the richest iron filigree. The brass and copper work has been dealt with in the same spirit, and the capitals supporting the screen are most happily adjusted to the requirements of architectural conventionalism. The copper flowers by which these are enriched have the softness and beauty of nature, though all, after the old style, are worked out with the point of the hammer from sheets of copper. The copper is throughout left of its own natural color, but the brass work is intermixed with broad masses of vitreous mosaic. Where paint is used upon the iron, all the colors employed, with the exception only of the green, have been obtained from oxides of the metal itself; though the coloring and gilding have been applied only with a view to

the effect of the whole piece when shown in the subdued light of a cathedral nave.

The whole composition consists of a double arcade of five primary and ten secondary arches, blended in a single group, though each retains its own individuality. The centre arch, forming the passage, is very lofty, and is enriched with the most exquisite scrolls of flower and foliage. The shafts for the arches are of mixed brass and iron; and, as at Lichfield, the whole is adorned with examples of architectural sculpture, figures of angels, &c. These figures are perfect studies in themselves.

In the Hardware Court were several descriptions of Cooking Apparatus, of which one showed great novelty of arrangement, namely, the patent Duplex Range, by Edward Deane & Co. It has two fires of different sizes, separated and backed by a T boiler. Each fire has a separate oven of proportionate size, flue, and hot-plate. In combination with the patent Revolving Roasting Apparatus—as many as nine joints can be roasted at one fire—120 pounds of meat may be roasted; the same quantity baked in the ovens; and the same quantity again stewed on the top of the stove; while the steam boiler at the back will boil 8 cwt. of potatoes, and the circulating boilers will keep 60 gallons of water constantly hot, the whole cost of the fuel per day being one shilling. The roasting apparatus consists of a cylindrical meat-screen, within which three sets of joints, one above the other, revolve first round a general centre, and secondly round their own axis, each joint having a separate dripping-pan.

Brown and Green, of Bishopsgate-street Within, obtained the prize medal for a large Kitchen Range, fourteen feet in length, containing four roasters, or ovens, and three boilers. It is stated that the range is capable of doing all the plain cooking for more than 2,000 persons with a consumption of less than one ounce of coal per head per day, this being one of the results of a practical trial of this range before it was placed in the Exhibition: these results are certified by the inspector of cookery for the army, who conducted the trial by command of the War Office. This large Kitchener also provided for the certain cure of smoky chimneys; the ventilation of the kitchen through the upper part of the range, whereby are prevented oppressive heat in the kitchen, and close smell of cooking; and the facility of roasting meat in front of the fire at the same time that the whole of the apparatus is kept going.

*Chandeliers, Gaseliers, and Lamps.*—Some of these tasteful works were designed by Mr. Digby Wyatt, and range in price from 50s to 100 guineas. Hinks and Son sent a case of new patent Lamps for the complete combustion of the commonest oils, without glass chimneys: some were glass elaborately gilt, and others of opal and bronze.

Harrow and Son, Portland-place, exhibited an Eight-light Gaselier, cast in brass, construc-

ted in form of an ancient grillier, or fire-pot, the upper bar consisting of eight inverted friezes, richly wrought and divided by heads of dragons, from whose mouths issue fire, and lightly-poised gas-jets. At the bottom is a very bold boss, composed of two large salamanders, intertwined in fierce struggle, their feet grasping the lower ring or bar of the suspended fire-pot, and thus forming its base.

The famous Birmingham Buttons, of gold and steel, and fanciful descriptions, were also tastefully shown. So perfect is the machinery for making buttons, that the manufacture is completely effected by the single revolution of a wheel.

Brass Tubing, some of it nine inches in diameter, a case of Bookbinding, in metallic covers; Brass Hinges, Door-knobs, and Handles, in endless array. The Cornice Poles and Brackets, by which small houses are most economically fitted, were exhibited here, made by the stamping process of Mr. Hill.

*Locks and Safes.*—Mr. Harley, of Wolverhampton, contributed a case of locks, remarkable for their mechanism and elaborate and artistic finish. Some of the padlocks were as small as the stone of a ring, and others as large as a cheese-plate; and some of the folio locks are also so minute that a dozen of them might be sent by post for two stamps.

Messrs. Bramah maintained their old reputation by exhibiting models and specimens of the well-known locks, as manufactured in their ordinary business. Hamilton and Co., Royal Exchange, showed a lock to be locked without a key, by merely turning a brass knob, but which is opened by a very small key.

Hobbs & Co. showed every part of a lock and key in course of manufacture by their machinery: they also exhibited a series of twenty-six locks, varying in size from that suited to the smallest cabinet to a large cupboard, so constructed as to be open with one and the same key. One of their larger locks, the "Protector," by a peculiar arrangement of certain parts behind the bolts and levers, is stated to be unreachably by any lock-picking instrument whatever. When any tampering is attempted on the lock by pressure on the bolt through the key-hole, to discover the opening position of each lever, the bolt-protector comes into action, preventing the pressure affecting the levers in any way.

Chubb and Son showed a splendid and unique collection of Locks and Keys. There were about 300 locks exhibited, varying between a gigantic rim lock weighing more than 2 cwt., and as finely finished as a lady's watch; and an elegant little gold lock, with four tumblers, set in a finger ring, and weighing 16 grains! Some fifty keys were shown with elaborate bows, three so much so, that, although small, they are valued at upwards of a hundred guineas; the bow of each being composed of minute particles of steel, all separately riveted, and resembling so many brilliants.



**STEEL MANUFACTURES.**—The manufacture of steel and steel articles, on anything like a large scale, is confined to very few countries. In 1851 it was ascertained that while we produced annually about 45,000 tons of steel, Austria, which came next to us, produced only 13,000, and all the states of the Zollverein taken together, but 8,000. Perhaps nothing indicates the progress which has been made during the past few years, so clearly as a comparison between the steel found at the Exhibitions of 1851 and 1862.

The so-called homogeneous metal, which has excited much attention of late, is extremely malleable and tough, and may be placed midway between wrought iron and ordinary steel; it may be regarded as steel containing a low percentage of carbon. This is the metal of which Mr. Whitworth has formed so high an opinion. Examples of it were exhibited by Shortridge, Howell, & Co. Pieces of tubing formed of this metal were shown flattened down vertically, which might readily be mistaken for caoutchouc. It is stated to have been produced by melting pieces of Swedish iron and carbonaceous matter.

In the French Department, Jackson, Son, & Co. exhibited steel objects made by the Bessemer process. The Swedes sent both iron and steel made by this process. Bessemer steel was sent from Kloster Works, Dalecarlia.

The process of Uchatius excited some attention a few years ago, especially in London. Samples were exhibited in the Swedish department. This steel, strange to say, finds a ready sale at prices ranging from £50 to £60 per ton, which are higher than can be obtained for Bessemer steel in Sweden. It is said to be especially good for sword blades. It is made by melting Bisberg iron ore, mixed with charcoal, in Belgian crucibles. This ore is remarkable for its purity.

Cast steel, made by melting together wrought iron and charcoal pig iron, was shown in the Swedish department, by Rettig, Geffe. Cast steel, made by melting together wrought iron and refined pig iron, was exhibited by Dr. Price, in the British Department.

In the Austrian Collection were specimens of the so-called wolfram steel, made by melting together cast steel and the mineral wolfram. It breaks with a very fine grain, and is hard and tough.

In the Austrian Department were drawings of Mayr's furnaces for casting steel on Siemens's principle by his "regenerative furnaces." Lignite is the fuel used, of which three parts by weight are required to melt one of cast steel. In six days between five and six tons are melted in one of these furnaces.

**Krupp's Cast Steel.**—Krupp affects considerable mystery in his processes. His works in Essen are reported to occupy 180 acres of ground. It is stated that he employs puddled steel, which is broken up, assorted, and remelted in crucibles. This variety of steel does

not appear to be adapted for cutlery. He consumes all the spiegeleisen produced by Müsenner & Co. It is affirmed that there is a great consumption of plumbago and leather parings at the Essen Works. Each crucible is said to contain 70 lbs. of steel, and the furnaces in which they are heated vary much in dimensions, the smallest holding two and the larger twenty-four crucibles. When a large casting is required, the organization has been carried to such a remarkable degree of perfection that, at a given signal, all the crucibles needed are ready to be taken out of the furnace at the same time. Their contents are poured with the utmost rapidity into a large reservoir, and from this the metal is cast. By this means, as in bronze founding, on the large scale, homogeneity is attained. The apparatus for working the steel is the most gigantic yet constructed. There is a steam hammer weighing 50 tons. The anvil face weighs 185 tons, and cupola furnaces were built expressly to melt this large quantity of metal. The largest casting in the world is the great bell at Moscow, reported to weigh 192 tons; but it cracked in cooling, and was never removed from its birthplace. Krupp's anvil rests on eight blocks of cast-iron, weighing from 125 to 135 tons each, and making a total weight of 1,250 tons of cast iron! This solid structure of iron is supported on a wooden foundation, 40 feet square. The largest casting exhibited by Krupp in 1851 weighed 2½ tons, and the largest in the recent exhibition weighed 21 tons. It is in the form of a solid cylinder, about 9 feet high, and 8 feet 8 inches in diameter. It has been broken across to show fracture. The largest casting Krupp ever made weighed 25 tons. Now, when we reflect that this enormous mass of metal is melted in comparatively small crucibles we get an idea of the perfect organization requisite to have every crucible ready and the pouring effected at almost the same moment of time; and it is in this organization that we are disposed to think one great merit of Krupp consists. Krupp exhibited shafts, rolls, railway tires and wheels, locomotive axles, and guns. There was a good catalogue in German, also a price list of the cast steel guns. A finished gun of eight inches calibre, turned, bored and rifled, without breech closing apparatus, is advertised at £975. Krupp has supplied locomotive axles to some of our largest railway companies, and crank axles of marine engines to some of our most celebrated marine engine makers.

**Bessemer's Steel.**—Bessemer made an admirable display both of iron and steel produced by this process; with specimens illustrative of the quality of the metal, as shown by hammering, punching, bending, twisting, stamping, rolling, drawing into tube and fine wire, turning, polishing, &c. A rail was shown 84 lbs. to the yard, which may be supplied at £13 per ton.

There were a crank shaft of a 50-horse engine in one piece; piston rods for engines of from 50 to 260 horse power; the powerful screw of

a fly press used in the mint; and a circular saw made from one disc of steel over 7 feet in diameter, with teeth of 10 inches in length. There was, however, a larger saw than this shown in another part of the building, made from steel by the old process; and either of them, turning at the rate of 500 revolutions a minute, would cut through the thickest timber as fast as a man could walk. With these massive examples were shown smaller ones, such as plates used in boilers, ships, and bridges, rising in regular gradations from 1-50th of an inch to nearly  $4\frac{1}{2}$  inches thick. Specimens of steel were also shown, from a thickness too great for a strong man to bend down to the 250th part of an inch in diameter.

Among the applications of steel wire were exhibited several specimens of cotton cards, used in the best carding engines, with steel in round, flat, and square bars of every size. Two important examples of steel ordnance were shown—one illustrating a mode of mounting guns without trunnions, the elevation being effected by a screw, and the axles of the wheels admitting of adjustment; the other a 24-pounder, with trunnions forged on it out of one solid ingot of steel. Mr. Bessemer also showed samples of railway bars made of his steel, some few hundred tons of which have already been laid on various new lines for trial. Naylor and Vickers showed a peal of beautifully sounding steel bells.

**WORKS IN THE PRECIOUS METALS.**—The workers in gold and silver have made great progress in their cunning art since the exhibition of 1851. In this age of gold, and nobler enterprise than that of gold seeking, and nobler successes than those of gold finding, it was natural to expect a large increase in costly works of art, and luxurious ministrations to the vanity which are too often showered upon individual success. But the advancement of art has not gone, *pari passu*, with this increment of the precious metals, and this liberal employment of those who fashion them. Art has been beaten, in common phrase, "by the weight of metal;" and though the quantity has been superabundantly increased, the quality of the workmanship has suffered in this plethora of the earth's wealth.

**Aluminium Articles.**—Aluminium alloys well with copper, forming what is now called aluminium bronze. When alloy of this kind, containing from three to five per cent. of aluminium, is "dipped" in aquafortis, it acquires a tint so like that of gold that it is impossible to distinguish one from the other, even when seen side by side. It is susceptible of a fine polish, and may be cast, rolled, hammered, and drawn out into fine wire. The bronze usually made contains 10 per cent. of aluminium. It possesses great tenacity, but tarnishes by exposure to the air.

M. Morin and Deville, in the French Department of the Exhibition, had an admirable display of aluminium, exemplifying every important quality of the metal. There were statuettes

and various cast objects, including latch keys, which combined lightness with strength; there was the metal rolled into large sheets, beaten into leaves, drawn into fine wire and woven into lace, coined into medals, plated upon copper; and aluminium bronze was shown in profusion, wrought as well as unwrought. The eagles on the standards of the French army are of aluminium; and examples of these were exhibited.

Leaf aluminium has lately been used for lettering in bookbinding.

**JEWELRY.**—The large diamond, "the Star of the South," was shown in the foreign nave, as a contribution from Amsterdam, by M. E. Coester; this diamond is of immense size, weighing no less than 125 carats. It is set in the centre of a magnificent star of brilliants.

A large brilliant drop, the property of Mr. Dresden, and the largest now for sale in Europe, was also exhibited; it weighed  $76\frac{1}{2}$  carats, or 306 grains; price £50,000.

Mr. Hancock exhibited, in his well-appointed display, a Diamond Necklace, the price of which was 85,000 guineas.

In Mr. Hancock's case was also exhibited the Devonshire Emerald (the largest in the world), and the Devonshire Jewels, one of the rarest and most artistic collections of antique gems in existence. These were shown amid a perfect galaxy of pearls, opals, rubies, brilliants, and topazes; in this case were exhibited jewels to the value of £300,000.

London and Ryder exhibited a wonderful specimen of diamond-setting, with a miniature portrait of the Queen, composed of distinct brilliants almost as fine as diamond dust, and of which more than 2,000 were required to complete the portrait.

Hunt and Roskell exhibited the Nassuck and Arcot diamonds, the property of the Marquis of Westminster. The Arcot consists of three gems, a round one, 125 grains, and two drops,  $223\frac{1}{2}$  grains; of the very finest quality and water. The Nassuck weighs 340 grains: it was bought by the late Marquis of Westminster for £7,000, and was once worn by his lordship on the hilt of his Court sword. Hunt and Roskell also showed a string of 32 remarkably fine pearls, each 39 grains, and the whole valued at £8,000. Widowson and Veale exhibited two strings of fine pearls, with two pendants, valued at £2,800.

Mr. Emanuel, in an ebony and bronze trophy in the nave, exhibited some costly articles; as an emerald brooch, mounted in diamonds, valued at £10,000.

Mr. Lambert's greatest novelty was some crystal intaglios engraved by Mr. Charles Cook, and afterward colored to the life; pretty objects of jewelry, either as lockets, brooches, or solitaires.

In Imitative Jewelry, Mr. Emanuel exhibited some ornaments made in ivory and gold inlaid with various gems—a process which he has patented—which certainly produce a good

effect; combining cheapness, softness, and a certain adaptability of color to almost any complexion or dress.

In the French Court were shown some imitations made by M. Savary, including a tiara of mock diamonds and some rings and other ornaments set with paste, rubies and emeralds, exceedingly close imitations of the real, which might be worn at a party without any risk of detection.

M. Vales showed some real and imitation pearls strung alternately on the same string; and so well made are the false that unless a jeweller had them in his hand and tested them by the weight and size of the bore, he would be unable to distinguish the imitation from the real. M. Topart had also four strings of pearls, two of them real and two false, which the uninitiated could not distinguish; yet one may be set down as costing about 8 franca, and the other about £800.

A fine specimen of Cameo-cutting was exhibited,—a head of the Emperor of the French—an admirable portrait—set in diamonds, which was bespoke by the Empress, at the price of £250.

**GLASS.—Stained Glass.**—The display of painted windows in the Exhibition was a very large one, and the first of the kind that has been seen in this country. It was, however, fuller of promise than performance,—in the original treatment of subjects, in place of copying epochal styles and methods of execution.

**Household and Fancy Glass.**—The manufactures of works of art in glass proved as attractive as any class of the Exhibition; the Austrian glass was good in color, and in their chandeliers was most effectively and artistically arranged; the Bohemian and Hungarian glass are special manufactures which were also admirably represented in the building; but the pure cut crystal glass, for exquisite forms, whether cut, blown, or moulded, and, above all, for the very highest effects of the engraver's art, the visitor found in the English Court. The display was really wonderful. Here were such triumphs of the engraver's art as Venice never knew; even wine-glasses fetched £6 and £7 apiece. There were lustres and chandeliers, too, of all descriptions and almost every grade of excellence—from the simple classic design of Dobson and Pearce, worth £12, up to the gorgeous crystal temple of Defries, which cost over £3000 to manufacture.

First, for fine art work, both in form and marvellous perfection of engraving, was the collection shown by Dobson and Pearce. One of the great gems in this collection—an engraved glass tazza, 12 inches high, was purchased almost the first day it was shown for 250 guineas, incomparably the largest sum ever paid for a single and very small piece of modern glass work. The panels in the cup, with their fine cup designs, are as delicately marked as steel engravings and as deep as intaglios, all cut with the wheel, even to the

minutest chasing of its flower scroll-work. A very small engraved Cup, not much larger than an ordinary tumbler, exquisitely engraved, was bought for 50 guineas the first hour it was seen. No piece of Venetian glass of the same size ever fetched so high a price.

A claret jug sold for 50 guineas, one side of which is deeply cut with a grotesque Raffaelesque design, of surpassing excellence; the foliage scroll-work—apes, dragons, and other monsters—being a perfect chapter, on the weird combinations of Raffaelesque ornament. The birds in this piece seem to have an actual plumage, so exquisitely is every feather worked out in the cutting. In a somewhat similar work, the centre ornament is a group of water-lilies floating in a lake, produced with an effect almost equal to an optical delusion. So also with fountains on another class of works—they are not so much engraved as they seem to flow and ripple from the very body of the vase. Above Messrs. Dobson's collection was hung a wonderful Venetian chandelier, of their modern manufacture, which in design and drooping of festoons was equal to the rarest old Venice types, only much more brilliant in its metal. In this collection were also shown the cheapest, simplest, and most beautiful designs of Mr. Marsh, of the Lord Chamberlain's office, for table decoration, which took the first prize at the Horticultural Society's fête last year. Messrs. Phillips exhibited in the form of a Crystal Table, the most brilliant piece of cut glass in the building. Behind it was placed a kind of épergne, or centre-piece for fruit and flowers, representing a pool with weeds and bulrushes in glass, and surrounded with nautilus-shells at the base, which altogether made up the most original and effective piece of this class in the display. Both these were manufactured by Messrs. Webb, of Stourbridge. Messrs. Pellatt's engraved glass also attracted such admiration that the firm received orders to make large dessert services of the same kind for the Prince of Wales and the Viceroy of Egypt: each service is to be so elaborate in design that many months will be required to complete them. The same firm showed cups, tumblers, and jugs of the most beautiful forms, covered with a perfect embroidery of exquisitely engraved designs: their copies of the Koh-i-noor in crystal glass, cut in the form in which this great diamond was first exhibited in 1851, were infinitely more brilliant than the renowned gem on its first début.

But in the general average of his exhibition of Cut Glass, Alderman Copeland had no superior. The jewelled dessert service of the brightest crystal, was a signal triumph of manufacturing skill: each piece has a lustre of its own that is brilliant beyond description.

One of the newest and most effective objects in Decorative Glass was shown by Powell and Co. These were vases of double glass, the outer one of pure flint, the inner colored to resemble dark serpentine marble. Between

the two are placed lightly printed photographs of statues, designs, flowers, &c., which show out as if finely engraved upon the marble: and these artistic effects are produced at the lowest possible cost.

Naylor exhibited some exquisite chalice-shaped cups, on which were engraved copies of the celebrated picture of the "Last Supper," equal to anything shown in the whole class.

One of the eight Prismatic Mirrors, which Messrs. Defries made for the late Sultan's new palace on the Bosphorus, was exhibited. This mirror is 15 feet high and 8 feet broad, and contains 1000 prisms. All the prisms join each other at the sides, so as to form one piece, and at the ends are dovetailed together and held into their place by a peculiar arrangement of copper rods. The weight of pure crystal is one ton, and the metal back one ton more.

**PORTRAIT.**—The largest work of this class in the building was the Majolica Fountain, placed under the eastern dome. In its variety of form and color it harmonizes with the internal arrangement and decoration of the building: it was designed and modelled by Mr. John Thomas, the sculptor, and executed under his superintendence for the display of Minton's modern majolica. The design, while very elegant and symmetrical as a whole, has that bold distribution of parts which is essential in a fountain to be in keeping with the wild play of water, especially in the open air. The mass of the fountain is in stone; the figures and ornaments, which are for the most part emblematical, being added in majolica. This is the finest work of the kind ever executed in this country, and proves that majolica may be made a most important department of industrial and decorative art.

The Wedgwood Collection, exhibited by the descendants of Josiah Wedgwood, nobly represented his famous ware in Etruscan vases, Nevers blue vases, and classic forms, painted with pastoral and other subjects.

A costly dessert-service, manufactured for Her Majesty at the Royal Porcelain Works, Worcester, by W. H. Kerr and Co., is unique in its application of color to enamels, enamel decoration to a service, and the general treatment of the design; its cost and difficulty of production being immensely increased by no device being repeated: while each plate contains five subjects, and for the plates alone upward of four hundred designs were made.

At the head of the French collection stood the magnificent manufactures of Sèvres. Here it was at once shown that the character of Sèvres is changed. It produces little of the old sort. Its royal blue is nearly as good as of yore; but its turquoise blue is dull, its *Rose de Barry* is very far from the mark, and its gilding wants lustre. Instead of these, however, we were presented with many other hues. Here were vases and cups of every form, and of many tints. Perhaps the most interesting part of the collection was a small

case containing three or four dozen cups; every cup almost was different—not merely in pattern, but in more essential qualities. There was not one which had not called forth the highest skill of the French artist, and would not fetch a fabulous price. The production of a sort of a sea-green ware—they call it "*céladon*," and a variety of it "*céladon changeant*"—which first appeared in the Paris Exhibition in 1855, may be regarded as the leading feature of the Sèvres display: The color is characteristic of modern Sèvres in this respect, that it is of a low tone. The primary colors are for the most part eschewed; so also the secondary ones; and those which are sought are the tertiary and still more complex combinations. What is here called *céladon* is most feebly translated in the epithet sea-green. It is a gray, dull sea-green of many shades, more or less allied to some old oriental ware, which it is more easy to recognise than to describe. This *céladon* is a body-color, it pervades the paste, and on it the French artists have succeeded in pencilling with a similar but white paste various designs, chiefly leaves and flowers, which stand out in gentle relief upon the vase or cup, white upon the *céladon* ground. The effect is very beautiful, especially in a variety of the *céladon* which is called *changeant*, because of the singular ease with which it reflects local color. By gas-light this *céladon* looks pink.

A small case bearing the name of Avisseau, of Tours, contained two pieces in imitation of Palissy ware—one a dish with a pike and other fish on it, the other a plateau, on which a heron is contending with a snake. It was extraordinary work. The glancing light on the skin of the pike and the eel in the one case, and of the snake in the other, was quite marvellous. In drawing, in action, in color, everything was perfect.

**Substances used in Manufactures.**—This class included not only raw materials, or substances, but the manufactures themselves. It was very miscellaneous, and presented comparatively few striking novelties.

**THE BRITISH COLONIES.**—*Jamaica.*—There was an abundant display of specimens of the products of this colony, such as sugar, rum, indigo, cotton, Indian corn, rice, bread-fruit, and bananas.

First were not less than 144 specimens of rum of the highest proof, in bottles; of all shades, from the pale pine apple color to the dark purple of port wine. Near the rums was a fine collection of the liqueurs and choice wines of the island, most exquisite in flavor, such as the pimento, the orange, the jamboline—a delicious liqueur; and the delicious Santa wine.

The vegetable oils of the country were represented by forty-eight specimens, some of great value in the arts, manufactures, and medicine. There was the wonderful croton oil, the sand box oil, and an oil called the "French physio-

nut," which is not so well known as its merits deserve; for a dozen drops will be as efficacious as an ounce of castor-oil, and its effects may be neutralized by a glass of white wine. In a glass case was shown a dry branch of a shrub, the "burwood," a specific against cholera.

*Trinidad.*—The produce sent from this island consisted of specimens of its minerals; asphalt, from the famous "Pitch Lake;" glance, tertiary coal, and lignite; the latter, it is said, will bear comparison with the best lignites from any other part of the world. The food substances included rice, ground nuts, seramum, cocoas, coffee, nutmegs, Brazil nuts, flower of bread fruit, plantains, yams, tania, sweet potatoes, curl-curl, bitter and sweet Canada arrow-roots, cloves, and black pepper. There were also vegetable oils and ivory, skins of sharks, sponges, seeds, &c.; textile materials, wild and cultivated cottons; cork, and fibres of wild cane; native woods, plain and ornamental calabashes, fancy baskets, Indian wickerwork, &c.

The mineral wealth of the island was represented by fine specimens of copper, manganese, zinc, cobalt, ironstones, barytes, arragonite, iron pyrites, sands, clays, and other matters.

The productions of British Dominica, and of British Guiana, had much in common with those shown from Jamaica.

*Natal.*—Sugar, in particular, within the last ten years has become one of the staple products of the country. Twelve years ago a sample manufactured from Natal canes was handed about the colony as a curiosity; but within the last two years 2,000 tons, exceeding £50,000 in value, have been exported.

Natal is trying her hand at producing cotton, and some specimens were shown of fair quality.

The greatest ingenuity is shown in their musical instruments. The Caffre lyre is a bent bow strung with twisted hair, which beaten with a stick will give out some four or five distinct tones; while the Macabere piano, which is a series of strips of wood, each backed by a sounding chamber formed of the rind of some dried and hardened fruit, has one or two notes very nearly approaching to the music of a cracked bell.

*St. Helena*, and one or two other African settlements, sent small contributions.

*The Bahamas* offered cotton, the pine apple fibre, the palmetto, the banana, and other plants containing fibres useful for the manufacturer; sponges and liquorice berries, and shell work, of various kinds.

*Ceylon* sent a fine collection of produce, natural and artificial. There were bows and arrows, and peacock's feather fans; rude ploughs and yokes; carved cocoa nut shells; native lace and gold embroidery, and musical instruments; and more especially interesting was a Davenport carved in ebony, in the English style, by a pupil in one of the industrial schools recently established in the island by the local government.

*Mauritius* sent some fine specimens of sugar, fruits, and vegetable substances.

*Hong-Kong* showed some choice examples of Chinese industry, in silk, rich velvets, silk and gold embroidered carpets; china and enamels; and articles of raw produce.

*Malta* came out very strong in her three great specialities, lace, silver filigree, and stonework. The beautiful black lace is made principally by women in the small island of Gozo. In the patterns there is scarcely any departure from ancient ideas—though the schools of design which have been established in Malta are beginning to tell both on this and other branches of manufactures—but the workmanship is so excellent that for wear the lace is unsurpassable. One of its distinguishing and most valuable characteristics is that it is impossible to crease it. The black lace is all of silk, obtained from Naples. There were also very beautiful specimens of white thread lace, mostly made in the charitable institutions of the island. In the silver filigree work, the delicate tracery is executed with quite as fine a finish as the best samples of the Genoese ware.

The chief articles which the Ionian Islands offered to commercial enterprise were their wines. The islands produce cotton in considerable quantities.

*India.*—The products of the soil were oil-seeds, oils, gums, resins, medicinal substances, fibres, timbers, and tea.

Rich samples of raw, manufactured, and dyed silks, were forwarded; while most of the contributing places furnished specimens of mixed silks and cotton fabrics.

The embroideries generally on velvet, silk, leather, and cloth, were excellent both in design and execution.

In works of art or skill, were the elaborate carvings in black wood, sandal wood, and ivory; and in a material termed "Ratangle," from Malabar; inlaid ivory, and enamelling in the precious metals.

There were samples of cutlery; jewellery, lac ware, &c., from Bombay and Scinde; and of mineral products and works in stone, &c.; alum, saltpetre, subcarbonate of soda, from Scinde; indigo from Jacobabad; sulphur, lead, copper ores, and galena, from Beloochistan; agates and carnelians from the Ruttinpoor mines in Rewa Kanta.

The collection from Madras under the head of raw products, included timbers, oils, seeds, gums, dyes, &c.

The rich feather ornaments from Kurnool and Vizagapatam, the large straw mattings from Pulhaut and North Arcot, the writing paper from Madras and Salem, and the carvings and constructions in ivory, sandal wood, buffalo horn, and porcupine quills, were attractive.

Hydrabad and Burmah contributed specimens of lac ware.

The fine arts in Madras were represented by a collection of engravings, photographs, and drawings. Some miniatures on ivory especially

illustrated the delicacy of finish, minute detail, and brilliancy of color, ever remarkable in native drawings.

The most remarkable portion of the *Canadian* display was that of her timber, of which there was a gigantic trophy in the north transept. It was three stories or stages in height. Some of the logs of which this trophy was formed were of enormous dimensions. On one side was a log of black walnut five yards in circumference; it was cut from a tree 120 feet high, the first limb being 70 feet from the ground, and 350 years old. On the opposite side was a large block of white oak, more than four yards in girth, and 380 years old.

The collection of woods of Lower Canada comprised the linden, the maples of various kinds, but especially the bird's eye maple; the moose wood, and the curled maple; the dog-wood, the willow, and the birch. In commercial value the most notable were the thirteen varieties of *conifera*, including pine, spruce, and cedar, the oaks and beeches, the hickory and the maples. These woods were, however, surpassed by those of Upper Canada, the most remarkable being the white oak, a plank of which is four feet wide; the black walnut, a beautiful wood for cabinet furniture; the sugar and soft maples, from three to four feet in width; and the pine, one plank of which is, we are told, "12 feet long (it could have been cut 50 feet long) and 50 inches wide, without a knot, sawn from a tree 22 feet in circumference, and 120 feet to the first limb.

There were also shown earthen and ores for paints; stones adapted for lithographers; mineral manures, as gypsum, phosphate of lime, shell marl, &c.; trap rock for grinding stones; talcose slate for whetstones, flagstones, and marbles.

*New Brunswick.*—Among the minerals were specimens of the Albert coal, black and glittering as jet, which will burn like a candle; and from which Albertine oil is distilled in large quantities. The mine is worked extensively by a company in New Brunswick, who have sunk one shaft to the depth of 750 feet, and are now sinking another, which it is expected will be continued to the enormous depth of 1,500 feet. One ton produces from 16,000 to 18,000 cubic feet of gas, or about eighty gallons of Albertine or paraffine oil. Some specimens of shale found a short distance from these works yield about sixty gallons of oil to the ton.

*Vancouver's Island.*—A spar of Douglas fir, of which specimens were exhibited, was brought from the island; it is 220 feet long, and now reared as a flagstaff in the Horticultural Society's Gardens.

*Prince Edward's Island.*—From this smallest of the group of North American colonies were sent a mowing machine; a variety of agricultural implements and products; and an ingenious running block, promises to create a revolution in ship's rigging.

*Nova Scotia.*—The zoological specimens of

this colony were prominent in the collection: a moose deer, grouse and partridges, ducks and waterfowl; fish, obtained in such large quantities in the neighboring waters; mackerel, salmon, pollock, haddock, hake, and cod; alewife and Digby chicken fish.

*THE AUSTRALIAN COLONIES.*—Of the almost unlimited natural wealth of the colonies of Great Britain, displayed in the Exhibition, Australia attracted the most attention; as well from the unprecedented rapidity with which her resources have been developed, as from the fine quality of some of the objects displayed.

*New South Wales*, the parent colony of the Australian group, takes the lead in pastoral industry. The colony owes its prominence in the production of wools to the enterprise of Capt. Macarthur, of Camden, who, noting the effect of the natural grasses on the fleeces of ordinary sheep, imported at his own expense three rams and five ewes of pure Spanish breed, with which he crossed all coarse-wooled sheep. The result of this patriotic enterprise was that in 1860 the export of wool from Sydney was 12,809,362 lbs., and its estimated value £1,123,699.

The samples of wools, fleece and scoured, were of admirable quality; and there were two or three fine Merino fleeces, one of which, the produce of an imported French merino lamb, weighed 7½ lbs. Mr. Ledger exhibited a beautiful sample of wool from the Alpacas, which he introduced into the colony from Peru with great success; the natural grasses suit them admirably, and Mr. Ledger is said to be confident that they will attain to maturity at an earlier age than in South America, with a larger form and a heavier fleece. In a large case were shown seven stuffed specimens—a pure lama, a pure alpaca, and five crosses between them.

The finest cotton exhibited in the building was to be found in the New South Wales Court, and some of the samples have been priced as high as 4s. per lb.; a sample which attracted much attention was grown 50 miles from the seacoast, in south latitude 33°.

In cereals, too, the colony took a high rank. The best sample was grown at Bathurst, and the three samples of white wheat, which run from 64 lb. to 68 lb. per bushel, grown at Camden park, were much admired. As a flour making wheat it is said to be of first rate quality. Maize seems to be a crop with which the soil and climate of New South Wales agree capitally, and some splendid cobs, both for size and close packing, of the grain were shown here. A sample of a most productive kind yields as much as 100 bushels to the acre; the large pure yellow sorts weigh 65 lbs. to the bushel, and the smaller yellow 66 lbs. There were numerous specimens of the products of the vines of New South Wales, including all the varieties grown there—Hungarian light wines, tokay—to which the muscat has a great affinity—Hermitage, Madeira, Bordeaux, and Burgundy. Since the Paris exhibition, when

the jurors reported strongly in their favor, the market for Australian wines has very much increased. Among the other products exhibited were Cayenne pepper, preserved fruits, tobacco, sponges, and sugar canes, for which some parts of the colony are said to be admirably fitted.

The portions of the show, however, both here and in the Victoria Court, which were looked at with the deepest interest by most people, were the specimens from the gold-fields.

*Queensland* made an excellent display. First, of cotton there were numerous samples. The quality of the sea island cotton is remarkably fine, and has been priced by authorities at 8s. 8d. and 8s. 6d. per pound. One sample, grown 200 miles from the sea-board, rivalled in quality that grown on the sea-coast. The principal export of the colony at present is wool, of which upwards of 5,000,000 bales, the produce of 8,500,000 sheep, are annually exported.

*South Australia* is unusually rich in copper, and the Burra-Burra, Kapunda, and the Wallaroo mines—from all of which, and other mines, there were ample specimens in the Exhibition—are reckoned among the most productive in the world. The Burra-Burra has been at work since September, 1845, and the annual yield for many years past has averaged from 10,000 to 13,000 tons of from 22 to 28 per cent. of copper. The specimens exhibited from the mine included sulphuret of copper in matrix of limestone; red oxide in silicious matrix; green carbonate with manganese; sulphuret associated with iron, from the lowest depth of the workings, yielding 50 per cent. of copper; and a number of beautiful pieces of the green carbonate or malachite. The specimens of Burra-Burra malachite completely eclipsed the famous Russian doors which attracted so much attention at the exhibition of 1851.

The samples of corn exhibited were of first-rate quality, superior to anything shown from the Old World, and only missing by an ounce or two the honor of being the heaviest in the building. About 8,500 acres are under cultivation as vineyard, and their produce amounts to 800,000 gallons of wine, besides 1,000 tons of table grapes, which are exported by steamer to Melbourne.

*Western Australia.*—The chief resources at present developed appeared to be timber and minerals.

*Victoria.*—The colonists had evidently taken great pains in this collection to illustrate the unexampled prosperity and almost boundless resources of their favored country. In 1851, the colonies of Victoria, Queensland, British Columbia, and Tasmania had no existence. In the short ten years that have intervened since then, they have grown into what may be termed distinct States, and one of them at least—Victoria—contains such elements of wealth, such boundless mineral and agricultural re-

sources within itself, as must in a few years make her the foremost and most powerful of the great cluster of our young southern empires. The rise and suddenly acquired and vast material prosperity of this colony transcend all that has yet been told of colonial enterprise. When the exhibition of 1851 was opened, the only habitation on the site of the present town of Ballarat was a shepherd's hut, built of slabs of wood, and roofed with bark. In a circle, having Ballarat as a centre, with a radius of 40 miles, the population then did not exceed 500 persons. The population of the same area in 1861 was 105,996 persons, the town of Ballarat 22,111.

At the East end of the building, in a beautifully carved wood case, was £50,000 worth of gold in every form in which it has been known or supposed to exist. There was a suggestive model illustration of this vast amount of Victoria gold.

The tall pyramid under the eastern dome, 44 feet 9½ inches in height and 10 feet square at the base, represented the bulk of the gold exported from Victoria from the 1st of October, 1851, to the 1st of October, 1861—the period from the close of the exhibition of 1851 to the date when it was necessary to send the goods from Victoria to the recent exhibition. The quantity of gold which it represents is 26,162,432 ounces troy; 1,798,995 lbs. avoirdupois; or 800 tons, 17 cwt., 3 qrs., 7 lbs. It is equal in solid measurement to 1422½ cubic feet; while the value of the gold thus represented, all of which has been exported to England, is 104,649,728½, or more than one-eighth of our national debt. On the surface of the pyramid were represented models of some of the larger nuggets which have been found, with reference to the names of their fortunate discoverers. On other portions of the surface there were representations of the ingots into which the gold was formed previous to exportation.

Here was gold in nuggets worth £10,000; gold in bars and massive ingots; gold almost black, red, yellow, and brown; rough masses crystallized into the most beautiful forms; gold mixed with crystals of iron spotted over the milk-white quartz-like rare gems, or cased in an impalpable powder got from the blankets or the crushing-machines, and so fine that it floats in water like a metallic lustre.

Specimens (weighing nearly 1 cwt.) of what may almost be termed native iron, so pure is the ore, were exhibited, containing between 80 and 90 per cent. of metal: they are found strewed over the surface of the earth in some parts of the colony like boulders.

Among other curious objects shown in this collection was a meteorite found near Ballarat, and weighing 80 cwt. A section of it shows graphite and magnetic pyrite in nests or patches through the mass, with chloride of iron exuding from the interstices. This most wonderful specimen of meteoric iron is, however, only a quarter the size of one found in the same colony. Among the natural produce exhibited were some samples of very fine tobacco.

Some exquisite French shawls and merino fabrics were shown, made entirely from Victoria wools: the former the most perfect specimens of the kind in the building, and the latter

equal to any of the best real Spanish merino manufactured in France. Some specimens of wheat weighed as much as 68 lbs. 8 oz. per bushel. Another fine collection, which weighed 87 lbs. 14 oz. a bushel, was stated to be the produce of the sixth crop reared in succession on the same land. The indigenous and acclimatized fruits were shown in a fine collection of wax models, cast from originals in Victoria for the purpose of being sent to this exhibition. Some of them, especially the pears, were wonderfully fine, the pears attaining sometimes to a weight of 3 lbs. There was also exhibited a fine and numerous display of highly scented essential oils from various native trees and plants. True kaolin, or the best porcelain clay, which enters largely into the production of soap wherever it is cheap enough, is found in abundance in Victoria. The manufacturers are utilizing the tallow by the production of candles, called "sperm," though made from stearic acid: some remarkable good specimens of these candles were displayed. There was shown dried meat called "charqui," which is almost peculiar to Victoria: it keeps fresh in the hottest climates during almost any length of time.

A Victoria street cab was shown. It is a kind of very broad dog cart, with high wheels like those of a Hansom; well balanced on its axle; it has three front and three back seats, sheltered by a large hood. A very good collection was shown of the principal fishes of Victoria, dried and stuffed, including among others, a specimen of the celebrated Murray cod: it is probably the largest fresh-water fish known, 150 lbs. being not a very unusual weight for it.

**Tasmania.**—This colony (formerly Van Diemen's Land, and one of our penal settlements) made a good display of its products, of which useful and ornamental timber was most prominent.

**FRENCH COLONIES.**—*Algeria.*—The French Government had evidently been at particular pains to present to the world an adequate idea of the resources and natural capabilities of its great colony; Algeria, in fact, occupying as much space as all the rest of the French colonies put together. The soil of Algeria still retains that wonderful fertility which made it in ancient times one of the granaries of Rome; and by far the most important part of the show was the long array of cereals, provender of various kinds, and vegetables. Natives as well as colonists exhibited here, and some of the finest specimens of barley were grown by indigenous cultivators. Of wheats there was an immense variety. The best sample shown was by M. Declonflé, of Constantine. Maize, too, white and yellow, is extensively grown both in the Oasis of the Sahara and the Tell. The exhibitors of barley, oats, and rye were numerous; and at the entrance there was a sheaf of each crop of the year's reaping. The Acclimatization Society exhibited a collection, in which there were not less than 58 varieties. Potatoes,

however, cabbages, and such vegetables as were classed under the head of tubercules, flourished in great abundance, and there was a large export.

The results of the cotton cultivation in Algeria were very interesting.

The cotton tree was shown in leaf and nut, with here and there the beautiful white cotton bursting from the pod. Mr. Hardy exhibited samples produced from seeds from all parts of the world which are in process of naturalization in the Jardin d'Acclimation at Algiers.

The production of silk in Algeria may be said almost to be one of the results of the French occupation of the country.

There was a considerable display of wines, both red and white; one special wine called vermouth, from Oran, has been described as an imitation of the famous Hungarian vermouth. The specimens of spirits and liqueurs included the renowned and familiar "absinthe," and the more recondite and almost unattainable "chartrreuse;" both the result of French industry and manufacture in the colony.

The appearance of tobacco grown in Algeria, in its raw state, and manufactured, in the shape of cigars and snuffs, was good. Here may be mentioned a very curious plant, like our common thistle, and from the pod of which is extracted a beautiful and delicate material which is woven into as beautiful and delicate silk, which is, besides, stout in substance, and the artificial colors of which are at once tasteful and rich.

Of the Thuya, the olive, and the other beautiful Algerian woods which are in such request among Parisian cabinet-makers for *meubles de luxe*, there were numerous specimens.

**PERU, COSTA RICA, AND URUGUAY.**—The South American States contributed various articles of produce and manufacture. Peru sent silver, silver and plated articles, and mercury; wools, including alpacas; and cotton and wine. From Costa Rica, mining and chemical substances; skins and furs. Uruguay, specimens of wool, roots, and skins, timber and wheat; lead, iron, copper, and coals.

**BRAZIL** sent twenty-four varieties of tea, including "Matti," coffee and sugar, wheat of good quality, and very heavy; tapioca, starch, arrow root, flour from various descriptions of grain; tobacco.

Brazilian manufactures: oils, including oil from the alligator, a black, thick, pitchy looking material; stearine candles; furs and skins tanned and dressed, the skin of an immense boa constrictor; boots and shoes of excellent shape and finish; cloths of various kinds; and felt hats of extraordinary lightness and fineness of texture. Excellent rum and native wines; and with those of beeswax and honey was shown a case containing twenty-four kinds of bees. There were creditable specimens of iron-casting, paper-hangings, wood-carving, and decorations of various kinds. The manufacture and cutting of glass was exemplified in some good specimens of design and engraving. Self-



feeding pistols and a variety of firearms and weapons were also exhibited.

Photographs were exhibited of the Emperor and Empress of Brazil and the imperial family; also of Brazilian scenery.

**JAPAN.**—Among the works was a collection of little metal buckles for fastening the dress; the designs of these buckles were irresistibly grotesque—not mere sketches, but solid little pieces of metal work, the background being of bronze and the raised figures in relief being either gold, silver, steel, or platinum, or of all four metals intermixed. It is evident from the platinum being so freely used that the secret of melting it, to which our chemical knowledge has only of late attained, has long been known to them. A small window-blind was shown, made apparently of rods of twisted glass strung together; the rods were as hard, as clear, and as sharp as glass; yet it was made from a gelatine of rice. In a collection of Ivory Carvings, a comic scene was distinctly represented—yet they were so small that they might be worn as brooches. In a collection of Porcelain, a large plate represented two Japanese ladies wearing French bonnets and shawls, with deeply flounced silk dresses spread out by an amplitude of crinoline. One had a telescope with which she was pointing to the sea with an air of fashionable nonchalance, while the other figure had her gloved hand filled with green apples. In the background were two other Japanese ladies dressed in the costume of the country, and who were shrinking with horror and astonishment from their strangely attired sisters. It is a curious illustration of manufacturing skill that a passing joke like this should be represented in such a costly medium as this beautifully finished porcelain.

There was a large collection of the different kinds of paper used for paper hangings, for writing, printing, and for wrapping up parcels; paper waterproof coats, paper leathers, paper parasols, and paper pocket handkerchiefs. Some of the paper leathers were as strong apparently as any hides that ever left a tanyard.

**CHINA.**—The Chinese exhibition, from the similarity of the peoples, much resembled that of the Japanese in its lacquered ware, its porcelain, its carvings, and its metal work in bronze. There was also a fine collection of medical drugs; with complete sets of Chinese types, rare ornaments in jade, and an exquisite wood carving, which formed the back of the Emperor's throne in his Palace of Yuen-Min-Yuen. Another of the spoils exhibited was a skull set in gold in the form of a drinking cup, looted from the Summer Palace by one of our private soldiers, and sold for a very small price, though the value of the setting is over £1000.

**AFRICA, CENTRAL AND WESTERN.**—The articles consisted mostly of tobes and native wrappers; grass cloths and mats; cotton clothes and sundry native manufactures, and specimens of cotton, in various states.

**MADAGASCAR** sent ores, clothes, and other

native manufactures: the scarfs in silk were very showy.

**HAYTI**, was represented by some Iron ores, Saddlery and Harness, and a few rude specimens of Pottery.

**THE EGYPTIAN COLLECTION**, consisted of the products of modern Egypt, of the Soudan, and the relics of ancient Egypt. The looms of Cairo contributed the largest proportion of the first division—and the silks were remarkable for the strength of their texture. In the patterns there was hardly any departure from the traditional stripes, but the lustre of the colors, even in the ordinary fabrics used by the fellahs for their fête dresses, was unusually splendid. The woollen and the cotton goods, too, were well represented.

From the arsenals of Cairo there was exhibited a stand of admirably finished Rifles, Bayonets, and other arms, used by the Egyptian army, and produced by Arab workmen, under the direction of M. Minié.

**FINE ARTS.**—“The English Gallery,” says an able critic, “affords an admirable opportunity of gaining an acquaintance with the most of what is worth knowing and studying in the history of Painting in England. The limits of time assigned to the exhibition of English pictures include all that there has been of painting in the country, while almost all, if not quite all, of those painters who ought to have a place in such a gallery are represented here. It is a collection as instructive as it is interesting. It is a condensation of all that we most wish to know, and most love to see in English art.”

*Architecture.—Designs and Models*, included drawings and edifices already built, and of many, in all probability, never to be built, but still useful as architectural examples and studies.

*Art Designs for Manufactures.*—The whole number did not much exceed three hundred, scarcely one third of them being the productions of the deceased artists—about twenty names in all of the latter. Each section contained some designs which either were of great merit, or had a certain interest historically.

*Sculpture* held a prominent and recognized position side by side with painting.

The majority of our modern sculptors exhibited, and the result was, a fine collection of about 120 statues, 40 or 50 busts, and 20 or 30 bas-reliefs.

A small collection of Intaglios, Cameos, and Medals—the latter containing many fine works of the Wyons, father and son—completed the general feature of this important Department.

*Etchings and Engravings.*—The Committee divided the specimens which the liberality of collectors had principally enabled them to exhibit, into five principal classes—etching, line-engraving, mezzotint, stipple, and wood engraving; and these were subdivided into works of deceased and into works of living engravers.

**FOREIGN PAINTING AND SCULPTURE.**—The Foreign display of Paintings, Drawings, Engravings, Sculpture, and Intaglios, was numerically as strong as the British exhibition.

France led off with about two hundred oil-paintings—specimens of the great French School; nearly 40 water-color pictures; 50 groups of sculpture; and about 180 engravings, lithographs, and architectural drawings. The pictures selected by the Imperial Commission were those painted by living artists since 1850, or those painted since 1840 by deceased masters born after 1790. The greatest novelties represented were the recent school of natural landscape, and domestic subjects. There were six specimens of Paul Delaroché.

*The Great German School of Painting* was well represented by the Zollverein, and other German States. Prussia sent nearly 200 works of art, in architectural designs, oil paintings, sculpture, and engravings. Berlin and Düsseldorf each sent a fine collection of paintings; and the engravings from the former city were choice and numerous.

BAYARIA sent about 40 works of art, chiefly oil paintings.

*The Austrian School* was represented by about 80 oil paintings, 16 water-color pictures, 19 pieces of sculpture, and a few engravings and architectural sketches.

HOLLAND exhibited about 120 oil paintings, and two engravings.

SWEDEN was represented by about 40 works in oil paintings and sculpture.

NORWAY sent some 50 oil paintings.

DENMARK sent about 110 works, including six groups of sculpture by Thorwaldsen, and five by J. A. Jerichau.

RUSSIA sent more than 100 works of art; 80 oil paintings, five groups of sculpture and medals, three architectural sketches, and seventeen engravings. The other pictures were remarkable for the insight they afforded into the Russian manners and ways of life, its humor and character.

BELGIUM contributed the most complete display: about 118 oil paintings, about 26 groups of sculpture and two engravings.

SWITZERLAND sent more than 100 oil pictures, SPAIN was represented by 80 works, in oil-painting, sculpture, and engraving.

PORTUGAL sent only two oil paintings, five photographs, and a few woodcuts.

ITALY was characteristically represented by about 40 architectural designs and 80 oil paintings and drawings; about 70 groups of statuary and busts.

ROME sent 57 pieces of sculpture; valuable cameos; a few fine drawings; many engravings;

a collection of medals; and a large assemblage of mosaics, including a contribution from the Vatican.

TURKEY, for the first time in the history of all Exhibitions, filled a place as an exhibitor of pictures.

GREECE sent two oil paintings, five groups of sculpture, and engravings.

BRAZIL contributed a few paintings, and a pen-and-ink portrait of the Empress; two carvings in wood; and medals and coins.

UNITED STATES.—The American fine-art numbered only about a dozen pictures and engravings, the chief of which was Mr. Cropsey's *Autumn on the Hudson*.

The foregoing summary has been compiled entirely from English sources, and on that account more prominence may have been given to the exhibits of England and its colonies. As an Exhibition, its success has not been equal to that of 1851 in fitness of the edifice, in the novelty of articles exhibited, nor in its financial results. The structure itself, criticized by rules of architectural art, or judged by its general effects on all beholders, has almost universally been regarded as a failure. In its constructive details, there has been much of credit to the engineer, but little to the architect. In the articles exhibited, there has been little of novelty or invention, but much to show the progress of art, and the improvement, especially in chemistry, in machinery, in processes already known, and of tools long in use. Since 1851, the production of coal-tar colors has become an industry, and the necessity of iron plating for war service has called for a class of tools of a size never before attempted. No new principles have been evolved, but the material and excellence of workmanship is in advance of anything before exhibited. The immense rolled and hammered iron plates, and the huge shafts of steel, are products which in 1851 could not have been produced, nor would have been attempted. The result of the Exhibition in building and in articles shown, may be summed up as an exhibit of what may be done by industry rather than by genius, and if it failed in its financial results, part was perhaps due to the war in our own country, part to the managers themselves, but more perhaps to the frequency of such exhibitions. Once in a quarter of a century should have been lapse of time brief enough to reproduce in any one country the Exhibition of 1851.

## F

FAYETTEVILLE, the capital of Washington county, Arkansas, has an elevated and picturesque situation in the northwestern part of the State, about 200 miles from Little Rock. It was the centre of an active trade, and had

flourishing schools, an institute for youth, three churches, a court house, and a United States land office. The population was about 1,500. The town was occupied by Federal troops of the division of Gen. Curtis, on Feb. 18, and

thus continued until they were withdrawn to the battle field of Pea Ridge, a few miles distant.

FELTON, CORNELIUS CONWAY, LL.D., an American author, born at West Newbury, Mass., Nov. 6, 1807, died at Chester, Pennsylvania, Feb. 26, 1862. He attended a private school at North Andover, from whence, after a thorough course of study, he entered Harvard College in 1827, where he was distinguished for his literary tastes and his fondness for Greek and Hebrew and the modern languages. During a portion of his junior year he aided in his own support by teaching mathematics in the Roundhill school at Northampton, under Messrs. Cogswell and Bancroft. After his graduation he was engaged for two years as principal of the Livingston high school in Genesee, N. Y. In 1829 he was called back to his Alma Mater to fill the office of Latin tutor, from which department he was transferred, the next year, to the Greek tutorship. In 1832 he was elected college professor of Greek, and in 1834 was appointed Eliot Professor of Greek literature, which position he continued to fill until his elevation to the presidency in 1860. In 1853 he visited Europe, travelling through the principal countries and devoting five months to Greece, ancient and modern, and again in 1858 he spent a portion of another summer in the same land. He examined the workings of her political institutions, visited the halls of legislation at the capital, and formed an acquaintance with the eminent scholars who adorn the university of Athens. Not long after his return from his first journey he published selections from modern Greek writers, and revised for publication Smith's "History of Greece," with notes, and a continuation from the Roman conquest to the present time. As a Greek scholar he was unsurpassed by any other in the country. He had a love of art which was cultivated by his devotion to a language and literature so calculated to improve and perfect the taste. He was deeply interested in everything that concerned Greece, her poets, orators, historians, and philosophers, but especially her monuments of art, and whatever reminded him of her ancient glory, or enabled him to understand more fully the meaning of her ancient writers. His works are numerous and of great value, perhaps the most important are: an edition of Homer, with English notes and Flaxman's illustrations, 1838; a translation of Menzel's "German Literature," and a "Greek Reader," 1840; an edition of the "Clouds of Aristophanes," 1841, republished in England. In 1843, in conjunction with Prof. Sears and Prof. Edwards, he prepared a work, entitled "Classical Studies." In 1847 appeared his editions of the "Panegyricus of Isocrates" and the "Agamemnum of Æschylus;" in 1849, the "Birds of Aristophanes;" and in 1852, "Selections from Greek Historians," and "Selections from the Writings of Dr. Popkin, with a Biographical Sketch." Among his original works are his life of Gen. Eaton,

in "Sparks' American Biography," upward of fifty articles in the "North American Review" and a large number in the "Christian Examiner" and the "New American Cyclopædia;" among the latter, are Agassiz, Athens, Attica, Demosthenes, Euripides, and Homer. Prof. Felton was a member of the Massachusetts Board of Education, a Regent of the Smithsonian Institute, and for many years a Regent of Harvard University. He died of disease of the heart at the house of his brother, while upon his way to attend a meeting of the Regents of the Smithsonian Institution, at Washington.

FERNANDINA is at the north end of Amelia island, on the east coast of Florida, 185 miles east by north of Tallahassee, the capital of the State. It is the terminus of the railroad from Cedar Keys, on the Gulf of Mexico. The entrance to the harbor is defended by Fort Clinch, which was evacuated on the approach of the naval expedition from Port Royal on the 3d day of March.

#### FINANCES OF THE UNITED STATES.

The national finances at the close of 1861 were in a very unsatisfactory condition. With large and increasing expenditures forced by circumstances upon the Government, the revenue had declined to a nominal amount, and the public credit, as marked by the prices of the stock exchange, was rapidly sinking. Distrust had seized upon the public mind, and the banks suspended specie payments on the last day of the year amid fears of a foreign war, which would largely increase the expenses of the Government. In this position the Secretary was compelled to come before Congress for loans of a magnitude very much in excess of those required at any former period. The misfortune had been that the war was from its inception regarded as of short duration. It was repeatedly urged at home and abroad that 60 or 90 days would finish it, and although its magnitude constantly increased and greater efforts in men and money were required, both were raised as temporary expedients. The public at first freely loaned its capital, but a very large proportion of what was then advanced was soon wasted while Congress refused to assume any responsibility in voting taxes. The first three months of the war had been conducted on voluntary offers from the people, and in the last six months of the year there were continued efforts to borrow. Congress had authorized loans of \$250,000,000. Of this amount \$100,000,000 had been borrowed in 3 year bonds at  $7\frac{1}{2}$  interest; \$50,000,000 in stocks 20 years to run, at  $6\frac{1}{2}$ ; \$50,000,000 in notes payable on demand to be used as a currency. From all these loans the Secretary had realized \$185,817,863, and there remained for the service of the six months that would close the fiscal year July 30, 1862, \$16,000,000 of demand notes, \$50,000,000 of 3 year bonds,  $7\frac{1}{2}$  interest, and \$25,705,871 yet undrawn of the \$50,000,000 not taken by the banks. These sums gave \$91,000,000 authorized, yet to be raised, to meet expenses estimated

at \$300,166,565.35 for the six months. If the 91 millions authorized should be obtained, there would remain a further sum of over 200 millions to be raised in six months, and the mode of doing this required to be promptly decided on, since the expenditure progressed at the rate of  $1\frac{1}{2}$  millions per day, with large arrearages to troops and contractors, which were pressing upon the Treasury with increasing severity. There were evidently but two ways in which the money could properly be raised. These were to borrow of those who had the capital to lend at the market rate, whatever that might be, and to levy promptly such taxes as would place the repayment of the loans beyond all manner of doubt. Unfortunately the Secretary and the committees of Congress entertained the idea that paper promises were capital, and that for the Treasury to borrow, it was first necessary to supply the paper to be borrowed, in the form of money. The Secretary said that he could not borrow in coin at better than 80 per cent., and would be required to pay nearly as much for bank notes, but that he could get better terms if Congress "furnished the currency." This idea, that it is the quantity of paper money afloat which determines how much capital the Government can borrow, seems entirely to have engrossed the mind of the Secretary and the views of the committees. He reproduces it on every occasion and in different forms. Thus—

The Government can resort to borrowing only when the issue of notes has become sufficiently large to warrant a just expectation that loans of the notes can be had from those who hold or can obtain them at rates not less advantageous than those of coin loans before suspension.

The extension of the United States note circulation, until sufficient in amount to enable the Secretary to obtain it from holders by way of loans, was equally inevitable.

Wherever the volume of notes reaches a point where a loan can be effected at rates fair to the country and desirable to takers, loans will, of course, be made, and ample opportunities for conversion offered.

This idea seems to have influenced the entire financial scheme of the Secretary. The fact that it is not paper promises that the Government seeks to borrow, but capital, is overlooked. The circulating medium, by the agency of which capital changes hands, is apparently confounded with capital itself. This is to suppose that if a limited amount of surplus capital exists in the country, that capital may be increased by the issues of paper money, and therefore a large issue of paper must precede the negotiation of a loan. When business and production were interrupted by the war, a large amount of capital thrown out of its usual employments was comparatively idle, and this sought temporary investment with the Government. The amount that could be so applied soon reached its limit. Long loans were not desirable, and for a reason similar to that which induced the Government to make short loans at the beginning of the war, namely, that peace might come in "60 or 90 days," when the capital would be wanted for the usual occu-

pations of commerce and industry. The Secretary therefore encountered an indisposition to take long loans, while the temporary capital was absorbed. He then supposed that he could increase the available capital by paper issues, and to make those issues float he decided upon a measure of doubtful constitutionality, in making them a legal tender. A bill to this effect encountered great opposition in Congress. The first effect of paper money is doubtless to cause an apparent increase of means; since, as in the present case, the possessors of capital had already parted with it to the Government, and now received pay in paper promises which they wished to employ temporarily. The circulation of the paper soon caused a rise in prices of all commodities, and that in proportion to its abundance, for the reason that all parties wished to avail themselves of the rise that they foresaw. With this rise more paper is required for the transaction of business. Hence, no matter how much may be issued, there will be no greater supply for the wants of the Government. The only capital which can be loaned to the Government, is derived from the profits of industry and commerce. When these profits are absorbed, the power to borrow ceases, no matter how much paper may be floating. Hence the idea that paper money will, when abundant, be readily converted into long stock is a fallacy. If, as measured in paper, a manufacturer gets for 10,000 yards of cloth, double price or \$20,000, he receives double the usual amount of money; but as he must pay in the same proportion for wool, labor, and other supplies, he can spare none of it for investment. He may indeed have suffered loss in the transaction. In this manner business absorbs inconvertible paper as fast as it is put out, and the Secretary was surprised to find, after he had issued \$250,000,000 of paper money, that the notes were more difficult to borrow than ever.

While the legal tender bill was before Congress, the Secretary had continued to draw from the banks the instalments due on the \$50,000,000 of that taken Dec. 1, and on Feb. 5 the last instalment, \$3,500,000, of the loan was paid up in the demand notes. The banks having suspended, and gold no longer in circulation, the Government had also suspended on those notes. The 19th of February was at hand, when \$1,875,000 interest was due in gold on the \$50,000,000 of  $7\frac{1}{8}$  notes that had been negotiated August 19.

The Secretary of the Treasury issued the annexed notice:

TREASURY DEPARTMENT, Feb. 4, 1862.

Holders of bonds of the United States, dated Aug. 19, 1861, and payable three years from date, are hereby notified that provision is made for the payment of the coupons of semiannual interest, which becomes due on the 19th inst., in coin, agreeable to their tenor, by the Treasurer of the United States at Washington, or by either of the Assistant Treasurers at New York, Boston, and Philadelphia.

All such coupons, together with schedules, showing the number and amount of each coupon and the aggregate sum of each parcel, must be presented for ex-

amination and verification at least three full business days before payment.

S. P. CHASE, Secretary of the Treasury.

The bonds were 1 per cent. discount for bank money, which still continued to be the currency, although it was depreciated 2 per cent. as compared with gold. A portion of the last instalment paid in by the banks on the stock was appropriated to the payment of the interest.

The currency was now in a peculiar position. The banks had ceased to pay specie, and the channels of circulation were filled with Government notes that the banks declined to receive on deposit, for the reason that they accumulated with them to an embarrassing extent. The notes were indeed receivable for customs, but the amounts required for that purpose were small, and if they accumulated with the banks it was the same as a loan to the Government without interest, and as the banks had already \$100,000,000 of Government stock it became burdensome. In this position of affairs the following notice was issued by the department:

OFFICE OF THE ASSISTANT TREASURER OF THE }  
UNITED STATES, NEW YORK, Feb. 8, 1862. }

The undersigned is authorized by the Secretary of the Treasury to receive on deposit United States notes as a temporary loan, for which interest at the rate of five (5) per cent. per annum will be paid, together with the principal, in like currency, on demand after ten days' notice.

JOHN J. CISCO, Ass't Treas'r U. S.

The following is a copy of the certificate which the Assistant Treasurer issued to depositors:

OFFICE OF THE ASSISTANT TREASURER OF THE }  
UNITED STATES, NEW YORK, ———, 186 . }

I certify that ——— this day deposited to the credit of the Treasurer of the United States ——— dollars, in United States notes, as a temporary loan, for which interest at the rate of five per cent. per annum will be paid, together with the principal, in like currency, on demand after ten days' notice, for which I have signed duplicate receipts.

§ ———, Ass't Treas'r.

The effect of this was to induce the banks to receive the notes from the public on deposit, and to place them to a certain extent with the Government for these certificates, which certificates were subsequently used for the settlement of balances at the bank clearing house. The deposits then made by the banks supplied some of the pressing wants of the Treasury. The money so received on being paid out to the contractors and other creditors, was by them redeposited in bank or used in the discharge of loans previously made. Thus the notes moved in a circle between the Treasury and the banks. The institutions, however, objected to allowing the public to make deposits with the Treasury on the ground that it would cause a withdrawal of deposits from the banks, when they were earning nothing, to the Treasury. This objection was, however, overruled, and deposits were received from the public at 4 per cent. Meanwhile the hesita-

tion of Congress to pass the bill authorizing a new issue of notes, and making them a legal tender, had induced action on the part of public bodies to urge its passage. The Chamber of Commerce, under the influence of the Secretary of Treasury, Feb. 8, passed resolutions, with very few dissentient voices, indorsing the legal tender clause of the currency bill, and urging immediate action. Some action was indeed imperatively necessary. The public creditors were clamorous and in great distress. In addition to creditors for small amounts, who were embarrassed by the exhaustion of the Treasury, one firm claimed two million one hundred thousand dollars for clothing, cloths, &c. Another five hundred thousand dollars for tent duck, and still others to almost an equal extent. There were, nevertheless, great difficulties to contend with. A great number of the members were unprepared to enter upon the perilous course of paper money, which was essentially revolutionary. A resolution to strike out a clause making notes a legal tender was, however, on the 8th of February defeated, 98 to 58. While this bill was pending Congress, on the 12th of February, authorized an additional issue of \$10,000,000 of notes similar to the \$50,000,000 authorized by the act of August. This amount, with the sums received on deposits, and the 3 year 7 $\frac{3}{8}$  bonds, which were paid out to creditors, although selling at 1 per cent. discount, enabled the Secretary to meet the most pressing demands upon the Treasury until the 25th of February, when the currency bill finally passed in the following shape:

*An Act to authorize the issue of United States notes and for the redemption or funding thereof, and for funding the floating debt of the United States.*

Be it enacted by the Senate and House of Representatives of the United States of America in Congress assembled, that the Secretary of the Treasury is hereby authorized to issue on the credit of the United States one hundred and fifty millions of dollars of the United States notes, not bearing interest, payable to bearer, at the Treasury of the United States, and of such denominations as he may deem expedient, not less than five dollars each.

*Provided*, however, that fifty millions of said notes shall be in lieu of the Demand Treasury Notes authorized to be issued by the act of July 17, 1861, which said Demand Notes shall be taken up as rapidly as practicable, and the notes herein provided for substituted for them: and *provided* further, that the amount of the two thirds of notes together shall at no time exceed the sum of one hundred and fifty million dollars; and such notes herein authorized, shall be receivable in payment of all taxes, internal duties, excises, debts, except duties on imports, and demands of every kind due to the United States, and of all claims and demands against the United States of every kind whatsoever, except for interest upon bonds and notes, which shall be paid in coin, and shall also be lawful money and a legal tender in payment of all debts, public and private within the United States, except duties on imports and interest as aforesaid; and any holders of said United States Notes depositing any sum not less than fifty dollars, or some multiple of fifty dollars, with the Treasurer of the United States or either of the Assistant Treasurers, shall receive in exchange therefor duplicate certificates of deposit, one of which may be transmitted to the Secre-

tary of the Treasury, who shall thereupon issue to the holders an equal amount of bonds of the United States, coupons or registered, as may by said holders be desired, bearing interest at the rate of six per centum per annum, payable semiannually, and redeemable at the pleasure of the United States after five years, and payable twenty years from the date thereof; and such United States Notes shall be received the same as coin at their par value, in payment of any loans that may be hereafter sold or negotiated by the Secretary of the Treasury, and may be reissued from time to time as the exigency of the public interests may require.

Sec. 2. *And be it further enacted*, That to enable the Secretary of the Treasury to fund the treasury notes and the floating debt of the United States, he is hereby authorized to issue on the credit of the United States, coupon bonds or registered bonds, to an amount not exceeding \$500,000,000, and redeemable at the pleasure of the United States after five years, and payable twenty years from date, and bearing interest at the rate of six per centum per annum, payable semiannually. And the bonds herein authorized shall be of such denominations, not less than \$50, as may be determined upon by the Secretary of the Treasury. And the Secretary of the Treasury may dispose of such bonds at any time, at the *market value* thereof, for (lawful money) the coin of the United States, or for any of the treasury notes that have been, or may hereafter be, issued under any former act of Congress, or for the United States notes that may be issued under the provisions of this act; and all stocks, bonds, and other securities of the United States held by individuals, corporations, or associations within the United States, shall be exempt from taxation by order or under State authority.

Sec. 3. *And be it further enacted*, That the United States notes and the coupon or registered bonds authorized by this act shall be in such form as the Secretary of the Treasury shall direct, and shall bear the written or engraved signatures of the Treasurer of the United States and the Register of the Treasury, and also, as evidence of lawful issue, the imprint of a copy of the seal of the Treasury Department, which imprint shall be made under the direction of the Secretary, after the said notes or bonds shall be received from the engravers, and before they issue; or the said notes and bonds shall be signed by the Treasurer of the United States, or for the Treasurer by such persons as may be specially appointed by the Secretary of the Treasury for that purpose, and shall be countersigned by the Register of the Treasury, or for the Register, by such persons as the Secretary of the Treasury may specially appoint for that purpose; and all the provisions of the act entitled "An act to authorize the issue of treasury notes," approved the 23d day of Dec., 1857, so far as they can be applied to this act, and not inconsistent therewith, are hereby revived and re-enacted; and the sum of \$300,000 is hereby appropriated, out of any money in the Treasury not otherwise appropriated, to enable the Secretary of the Treasury to carry this act into effect.

Sec. 4. *And be it further enacted*, That the Secretary of the Treasury may receive from any person or persons, or any corporation, United States notes on deposit for not less than thirty days, in sums of not less than one hundred dollars, with any of the assistant treasurers or designated depositaries of the United States authorized by the Secretary of the Treasury to receive them, who shall issue therefor certificates of deposit, made in such form as the Secretary of the Treasury shall prescribe, and said certificates of deposit shall bear interest at the rate of five per centum per annum; and any amount of United States notes so deposited may be withdrawn from deposit at any time after ten days' notice on the return of said certificates: *Provided*, that the interest on all such deposits shall cease and determine at the pleasure of the Secretary of the Treasury; and *provided* further, that the aggregate of such deposits shall at no time exceed the amount of twenty-five million dollars.

Sec. 5. *And be it further enacted*, That all duties on

imported goods which shall be paid in coin, or in notes payable, or in demand notes, heretofore authorized to be received and by law receivable in payment of public dues, and the coin so paid shall be set apart as a special fund, and applied as follows:

*First*. To the payment in coin of the interest on the bonds and notes of the United States.

*Second*. To the purchase or payment of one per centum of the entire debt of the United States, to be made within each fiscal year after the first day of July, 1862, which is to be set apart as a sinking fund; and the interest of which shall in like manner be applied to the purchase or payment of the public debt as the Secretary of the Treasury shall, from time to time, direct.

*Third*. The residue thereof to be paid into the Treasury of the United States.

This very important law produced an entire change in the currency. It provided for 150 millions of legal tender paper money, which was available for all purposes of currency except custom duties and interest on stock, both of which were to be paid in coin. The outstanding \$80,000,000 of demand notes, by the acts of August and February 12th, were receivable for customs. Hence gold could not be realized for duties until those notes should be absorbed. They were by the law endowed with a specific specie value, since they were alone a substitute for specie at the custom house. The new issues of demand notes being a legal tender, at once took the place of gold as a means of redemption for bank notes, and thus relieved the banks from the dilemma in which under the State laws they had been placed by the act of suspension. When compelled to forego specie payments they contracted their obligations, and made efforts to place themselves in a position speedily to resume. The contraction of the currency thus brought about added to the difficulties of the moment. As soon, however, as a flood of Government paper was authorized as a tender in lieu of specie, the banks renewed their expansive movement, and began to increase their circulation. The 60 millions of old notes which they had at first refused to receive at all, and then tolerated when they could be deposited with the Government, now became in active demand.

The banks would no longer deposit them with the Treasury without a stipulation that they should receive back the same kind of notes, and as some time must necessarily elapse before the new notes could be got ready, this stipulation was agreed to. When the banks suspended and specie rose to a premium, it immediately ceased to circulate, and began to disappear altogether. This fact caused great inconvenience, since, there being no Government notes less than \$5, and the banks not disposed to increase their issues, the want of small circulation was urgently felt. As soon, however, as, by the law of Feb. 25th, the banks were allowed to redeem their circulation in the Government notes, they began eagerly to supply small currency.

The wants of the Treasury for the moment continued very pressing, notwithstanding the large supplies granted by the law of Feb. 25th, because some weeks must elapse before adequate

amounts could be prepared by the engravers. The current expenses were one million two hundred and fifty thousand dollars per day, partly met by the receipts on deposit; but there were also large arrearages, amounting to \$50,000,000 and more, due to creditors, who were pressing for pay. These persons had constituted a class of urgent borrowers in the market, and as capitalists hesitated to lend freely on simply approved claims, the public creditors were compelled to submit to heavy loss to realize money. To relieve these classes, Congress, at the request of the Secretary, passed March 1st the following law:

*An Act to authorize certificates of indebtedness to the public creditors.*

*Be it enacted, &c.,* That the Secretary of the Treasury be and he is hereby authorized to cause to be issued to any further creditor who may be desirous to receive the same, upon requisition of the head of the proper department, in satisfaction of audited and settled demands against the United States, certificates for the whole amount due, or parts thereof, not less than one thousand dollars, signed by the Treasurer of the United States, and countersigned as may be directed by the Secretary of the Treasury, which certificates shall be payable in one year from date, or earlier, at the option of the Government, and shall bear interest at the rate of six per centum.

This important measure gave the Secretary unlimited authority to borrow on twelve months. This is the first instance where the Secretary of the Treasury was allowed to use the credit of the Government without limit. It operated in fact, as far as the certificates were accepted by the creditors, as an extension of twelve months on the floating debt of the Government, and bridged over the period required for the negotiation of the 6 per cent. bonds authorized by the act. Any creditor of the Government, whose claim had been approved, could now at once obtain a 6 per cent. interest-bearing obligation of the Government, which he could sell or use as first-class collateral for loans.

The following rules and regulations were issued by the Secretary of the Treasury:

Congress having authorized the issue of certificates of indebtedness by the Secretary of the Treasury, in payment of audited and settled demands against the Government, as well as in payment of checks, drafts drawn by disbursing officers upon amounts placed to their credit with the Treasurer of the United States, in favor of creditors who have furnished supplies, &c., and who are willing to receive such certificates in satisfaction of their demands, the following regulations are presented, and will be strictly observed in the execution of the act:

The certificates of indebtedness will be payable to the claimant or creditor of the Government, or his order, and in the denominations of \$1,000 and \$5,000. Certificates of the larger denominations will be issued in all cases where the nature of the claim will admit of it. A book will be opened by the Treasurer of the United States, in which shall be kept a record of each certificate issued under authority of the act; the name of the person to whom issued; the date, number, and amount thereof; on what account; if on Treasury warrant, the number thereof, and if on draft or check of a disbursing officer, the name of the officer by whom drawn, the date and amount of such check or draft, &c.

The certificates shall be signed by the Treasurer, and countersigned by the Register of the Treasury, who shall also keep a complete record of said certificates, as required of the Treasurer. If issued upon a warrant, they will bear even date therewith; or if to a disbursing officer, then with the date of the presentation of his deed or draft on the Treasurer of the United States.

When the Secretary of War or Navy may desire to leave a credit on the books of the Treasury in favor of a disbursing officer of his Department, he will draw his requisition on the Secretary of the Treasury in the usual form for the amount desired to be placed to the credit of such disbursing officer, and specify the appropriation properly chargeable.

Upon such requisition being received at the Treasury Department, a warrant will issue to the Treasurer, and he will accordingly place the amounts to the credit of the disbursing officers named, who will then be authorized to draw checks or drafts thereon, to the amount of such requisition, in favor of such creditors entitled to payment by him as may desire to receive such certificates in satisfaction of their respective demands.

The checks or drafts of disbursing officers will be in the following form:

§ ————— 1862.  
The Treasurer of the United States will pay to ————— or order, on certificates of indebtedness ————— dollars, being amount due for —————, as will appear by bill and receipt therefor, in my possession, and which will be rendered as a voucher in my accounts for the ————— quarter of this year.

(Signed)

To F. E. SPINER, Treasurer of the United States.

As the certificates of indebtedness are only to be issued in payment of creditors, and for amounts liquidated and actually due them, the disbursing officer, before drawing his check or draft on the Treasurer, will take the same voucher from the creditor, and will, in all respects, be subject to the same responsibilities as if making payment in coin or United States notes.

The requisition in favor of the officer will be charged on the books of the accounting officer as other requisitions, and vouchers will go into the general accounts of the disbursing officer, and be settled with his other accounts.

The issue of these certificates gave great relief by causing capital to circulate more freely, and the department was less dependent on the money received from deposits to meet current expenses, as those deposits were made in demand notes, which were receivable for duties, and which it was important to get up as soon as possible, in order that the Government might be in receipt of gold through the custom house, and thus be enabled to pay the interest on the Government stock without purchasing gold. The department therefore ordered as follows:

OFFICE OF THE ASSISTANT TREASURER OF THE }  
UNITED STATES, NEW YORK, March 14, 1862. }

Under instructions from the Secretary of the Treasury, I hereby give notice that all certificates bearing five (5) per cent. interest, hereafter issued for deposits of United States notes, will be payable in whatever notes may have been made a legal tender by act of Congress, and may be, at the time when repayment shall be called for, paid out usually to public creditors.

JOHN J. CISCO, Assistant Treasurer U. S.

The effect of the notice was to check the temporary deposit of demand notes for 5 per cent certificates.

It was now apparent that although the law of Feb. 25th had intended to make the first issue of \$60,000,000 a legal tender, like the new

one authorized. It had not really done so, and the banks would not use them as a basis for issues. A new act was therefore necessary, and it was passed March 16th, as follows :

*An act supplemental to the Treasury act of March 1, adopted by Congress, and approved by the President on the 16th of March, 1862.*

*Be it enacted by the Senate and House of Representatives of the United States of America, in Congress assembled, That the Secretary of the Treasury may purchase coin with any of the bonds or notes of the United States, authorized by law, at such rates and upon such terms as he may deem most advantageous to the public interest; and may issue, under such rules and regulations as he may prescribe, certificates of indebtedness, such as are authorized by an act entitled "An act to authorize the Secretary of the Treasury to issue certificates of indebtedness to public creditors," approved March 1, 1862, to such creditors as may desire to receive the same, in discharge of checks drawn by disbursing officers upon sums placed to their credit on the books of the Treasurer, upon requisitions of the proper departments, as well as in discharge of audited and settled accounts, as provided by same act.*

*SEC. 2. And be it further enacted, That the demand notes authorized by the act of July 17, 1861, and by the act of February 12, 1862, shall, in addition to being receivable in payment of duties on imports, be receivable, and shall be lawful money and a legal tender, in like manner, and for the same purpose, and to the same extent, as the notes authorized by the act entitled "An act to authorize the issue of United States notes, and for the redemption or funding thereof, and for funding the floating debt of the United States," approved February 25, 1862.*

*SEC. 3. And be it further enacted, That the limitation upon temporary deposits of the United States notes with any Assistant Treasurers or designated depositaries, authorized by the Secretary of the Treasury to receive such deposits, at five per cent. interest, to twenty-five millions of dollars, shall be so far modified as to authorize the Secretary of the Treasury to receive such deposits to an amount not exceeding fifty millions of dollars, and that the rates of interest shall be prescribed by the Secretary of the Treasury, not exceeding the annual rate of five per centum.*

*SEC. 4. And be it further enacted, That in all cases where the Secretary of the Treasury is authorized by law to reissue notes, he may replace such as are so mutilated or otherwise injured as to be unfit for use, with others of the same character and amount; such mutilated notes, and all others which by law are required to be taken up and not reissued, shall, when so replaced or taken up, be destroyed in such a manner and under such regulations as the Secretary of the Treasury may prescribe.*

By this act the Secretary was authorized to purchase coin for the payment of the interest on the public debt. He was also authorized to extend the issue of 1 year certificates to the discharge of checks of disbursing officers, also without limit as to amount. The old or "gold notes" as they were called, because they were substitutes for gold at the custom house, were made a legal tender, and the limit of deposits raised to \$50,000,000. All these acts placed ample means apparently at the service of the department. It had 100 millions of notes to issue, an unlimited amount of 1 year certificates; \$500,000,000 of 6 per cent. stock; 50,000,000 of deposit certificates, and about 87,000,000 of three year  $7\frac{3}{8}$  bonds still on hand to issue. These had indeed been paid out until the price fell to 8 per cent. discount in the market.

The certificates of indebtedness were then substituted until they fell to  $95\frac{1}{2}$ , or  $4\frac{1}{2}$  per cent. discount, at which rate they would afford the buyer  $10\frac{1}{2}$  per cent. interest in gold for money payable in a year. The leading creditors of the Government then declined to take the certificates any longer, and the checks of disbursing officers were sold at  $4\frac{1}{2}$  per cent. discount. In order to stay this depreciation the Secretary issued a notice that he would pay in cash 20 per cent. of the amount of certificates in the hands of original holders. Thus if a person held \$100,000 of certificates, the Secretary would redeem \$20,000 in cash. This, by diminishing the amount on the market, caused a little recovery in the price, and they rose to  $97\frac{1}{2}$ . The 1st of April was now approaching, when the interest, \$1,875,000, was due on the \$50,000,000 of 8 year bonds issued Oct. 1st. The Government purchased a portion of the requisite specie, concentrated all held at the Government deposits, and effected the payment. On the 24th of March the Treasurer sold \$3,000,000 of the  $7\frac{3}{8}$  bonds for demand notes at par and interest. The proceeds were sent west for army purposes.

It is now to be observed that in all these movements there had as yet been no expansion of the currency. On the contrary, there had been a contraction. The circulation of the banks of the Northern States had, at the close of 1861, been nearly \$140,000,000, and the Government had issued \$30,000,000 of demand notes, making \$170,000,000 of paper, in addition to the specie in circulation. On the last day of the year the banks suspended specie payments. Gold and silver gradually ceased to circulate, and the banks in the uncertainty which involved the future began to curtail their obligations. This was followed, on the passage of the act authorizing legal tender notes, by the withdrawal of the Government demand notes from circulation. Hence, while the Government was issuing 8 year bonds and 1 year certificates, the circulating medium was greatly contracted, as was proved by the fact that gold, which was 5 per cent. premium January 1st, was  $1\frac{1}{2}$  to  $1\frac{3}{4}$  per cent. April 1st, when the new legal tender notes were ready for circulation. The Government finances had at the same time received support from the success of the Western armies, which had apparently broken the strength of the Confederates and given rise to hopes of peace. This circumstance, together with the prospect of the passage of some adequate tax law, had caused a recovery in the prices of some descriptions of stocks. The banks held, when they suspended, at the close of December, over seventy millions of Government securities, mostly 6 per cent. and 8 year  $7\frac{3}{8}$  per cent. treasury bonds. They had taken the former at a rate equal to 89.82, and the latter at par. January 1st, the former were at 88, and the latter at 2 to 3 per cent. discount, and gold at 5 per cent. premium. In other words, the stock for which the banks had paid



89.82 in gold was worth only 86 in gold. Gradually the price rose to 94 for stock and par for the bonds, while gold, after rising to 5 per cent. premium, fell back to  $1\frac{1}{2}$  and  $1\frac{1}{4}$ . Hence the banks could make a profit by selling their stock for gold, and they could discount paper by paying out the 8 year bonds to be sold by the borrower. The securities disposed of by the banks were, to some extent, purchased by the public. The Government which had obtained such large supplies of capital from the public in various shapes, ships, steamboats, clothing, food, munition, &c., was now ready to pay out the paper for them, and the payments took place as fast as the printers could deliver the money. The paper so poured upon the market began at once to inflate the currency. The creditors who received it discharged their debts with it, and it accumulated with the banks, which freely offered to loan it, at lower rates of interest. The Treasury was

the reservoir that received it from the public at 5 per cent. interest, and this fact made 5 per cent. the minimum price of money, since no one would take less than he could get from the Government. The legal limit of \$50,000,000 was thus rapidly filling up, and on the 26th of April the Secretary ordered the rate of interest to be reduced to 4 per cent., except for banks, which were still allowed 5 per cent. interest. The limit of \$50,000,000 was completed by the close of April, and the Assistant Treasurer determined on paying off all 5 per cent. deposit certificates, and allowing only 4 per cent. for new deposits. He refrained from this, however, and only received deposits at 4 per cent., as the old ones were voluntarily withdrawn.

The issues of these various descriptions of government paper continued, and at the close of May an official report of the public debt was made by the Secretary, showing the following results as compared with Dec. 1st:

## UNITED STATES DEBT.

	December, 1861.	May 28, 1862.	Decrease.	Increase.
Old debt.....	\$70,104,955 91	\$70,104,955 91	....	....
Oregon war debt.....	807,900 00	878,450 00	....	\$570,550 00
Treasury notes, old.....	105,111 64	105,111 64	....	....
"    "    1857.....	664,200 00	175,900 00	\$488,300 00	....
"    "    1860.....	9,983,950 00	221,650 00	9,712,300 00	....
"    "    2 years.....	7,767,600 00	2,767,900 00	4,999,700 00	....
"    "    60 days.....	8,998,900 00	111,600 00	3,882,300 00	....
3 years' bonds, $7\frac{3}{10}$ per cent.....	100,000,000 00	120,523,450 00	....	20,523,450 00
20 years' stocks, 6 per cent.....	50,000,000 00	50,000,000 00	....	....
Demand notes.....	27,940,000 00	145,880,000 00	....	117,940,000 00
1 year certificates, 6 per cent.....	....	47,199,000 00	....	47,199,000 00
5-20 years' bonds, 6 per cent.....	....	2,699,400 00	....	2,699,400 00
Deposits' certificates, 5 per cent.....	....	50,778,566 56	....	50,778,566 56
Total.....	\$270,817,617 55	\$491,445,984 11	\$19,082,600 00	\$289,710,966 56

Thus in six months the debt had been actually increased \$220,628,366.56, and there had in addition been converted \$19,082,600 treasury notes into paper payable on demand. The whole amount raised was in demand loans, of which \$117,000,000 was in paper money, \$47,000,000 in one year certificates, and nearly \$51,000,000 in deposits. The appeal of the Secretary for conversion into the 5-20 bonds had been productive of only \$2,699,400. It might therefore be said that there were during that period absolutely no loans of capital to the Government. The 8 year bonds had been paid out to creditors, with the exception of the \$3,000,000 negotiated at par at the close of March. The Secretary had extended the note circulation by \$57,000,000, and the amount outstanding was now equal to the whole circulation of the banks. The whole paper currency had therefore been doubled, but there was no manifestation of any desire on the part of the public to convert notes into stock. It is true that the old notes making one half the amount of Government notes outstanding were withdrawn from circulation, and held for the use of importers in their payments to the custom house, at continually rising prices, marked by the depreciation of the Government currency, which was now  $7\frac{1}{4}$  per cent. discount for gold. The point of "extended circulation" which the Secretary supposed

would bring with it "increased facilities to contract loans," was not yet reached. The public did not take the 5-20 stock. The Secretary ascribed the failure of the loan to the terms of the law, which make the bonds convertible at par, and permit the Secretary to sell them at the market value. He objected to the first provision that while the bonds were convertible at par to all the world, the brokers and speculators, who might otherwise "take considerable amounts," could make no profit, since the price could not rise above par, when everybody had a right to take them at par from the Treasury. The provision to sell only at "market value" was objectionable in his view for the same reason, since it gave no advantage to large operators. He therefore desired the repeal of those provisions, and the granting of a "discretionary power" to the Secretary in the making of these loans. Meantime he was again destitute of resources. The deposits and 1 year certificates did not suffice to meet current expenditures, and he again appealed to Congress for an issue of paper money.

The approach of the month of July, when more than \$4,000,000 of specie were due the holders of United States stocks for interest, rendered some effort necessary to obtain it without coming into the market as a purchaser, as that would act upon the premium on gold in

the market; an exchange was made of 8 year  $7\frac{3}{8}$  bonds for the gold, both gold and bonds bearing the same price in the market. This operation was the same as compounding the interest at 7.80 per cent.

A considerable portion of the \$50,000,000 deposits on hand, and for which 5 per cent. certificates were outstanding, was payable in the old issue of demand notes, which bore a premium in the market proportionate to that of gold, for which they were substitutes at the custom house. Thus there were two kinds of certificates out: one payable in legal tender notes not receivable for customs, and one payable in the old or "gold notes." On the 5th of May the Sub-Treasurer issued the annexed circular:

UNITED STATES TREASURY, NEW YORK, May 5, 1862.

Under instructions from the Secretary of the Treasury, I hereby give notice to all holders of certificates of deposit bearing interest, issued prior to the 14th day of March ultimo, and payable in "United States notes issued under acts prior to February 25, 1862," that they are required to present such certificates within ten days from the date hereof for payment of principal and interest, or for exchange for certificates payable in "lawful money of the United States." Any such certificates not so presented, will, after said ten days, be payable in such lawful money as the Government may be usually paying out to the public creditors.

JOHN J. CISCO, Assist. Treas. United States.

This had a twofold operation; it cleared the Treasury of the obligation of paying out the gold notes, and it enabled it to take new deposits payable in "lawful currency" at 4 per cent. instead of 5 per cent. The notes were withdrawn, and by the 22d of May the limit of deposits was again full. A new difficulty now presented itself. On the entry of goods at the custom house the complications of the new tariff had made it requisite that the merchant should deposit an estimate of "gold notes" to cover the duties. When these were accurately adjusted the amount, if any, overpaid, was returned to him. The Secretary directed that these amounts should be returned in new notes, which were less valuable than those which had been deposited. The merchants demurred to this, claiming that they had a right to receive back the same kind of money that they deposited, since that money was not currency but a special medium, which they were obliged to buy at a premium for custom house purposes. In answer to these complaints the Secretary issued the following order:

TREASURY DEPARTMENT, May 21, 1862.

SIR: I am in receipt of your letter of the 19th instant, inclosing a petition from the prominent importing merchants of the city of New York, asking that your instructions relative to the payment of all dues except interest and duties be so far modified as to permit the payment of all checks drawn by the Collector of Customs for "excess of unascertained duties" in notes of the first issue or coin.

Their request is deemed reasonable and just, and you are hereby authorized to pay all checks drawn by the Collector which shall contain the words "for excess of deposits for unascertained duties" in such money as is receivable for duties at the custom-house.

I am very respectfully,

S. P. CHASE, Sec. of the Treasury.

JOHN J. CISCO, Esq., Assistant Treasurer, New York.

The trouble of paper money seemed to multiply at every turn. It was discovered that a very ingenious fraud was perpetrated to a considerable extent on the Government notes. It was found that nine \$10 notes might be so mutilated and rejoined that 10 complete notes could be formed to the great profit of the operator. As a consequence of the discovery, all mutilated notes, and they had become very numerous, were refused; but the evil was very great, subjecting innocent holders to loss, and the following circular was issued as a corrective:

TREASURY DEPARTMENT, WASHINGTON, May 18, 1862.

To guard against frauds upon the Government, and to secure the just rights of holders, the following rules, for the redemption of mutilated United States, are hereby established:

#### RULES.

*First.* Mutilated notes, which have been torn, no matter how much, but of which it is evident that all the fragments are returned; or defaced, no matter how badly, but certainly satisfactorily genuine, will be redeemed at their full face value on presentation.

*Second.* Fragments of notes will be redeemed in full only when accompanied by an affidavit, stating the cause and manner of the mutilation, and that the missing part of the note is totally destroyed. The good character of the affiant must also be fully vouched by the officer before whom the affidavit is taken.

*Third.* In the absence of such affidavit, fragments of notes will not be paid in full, but the parts represented will be redeemed in their proportion to the whole note; reckoning, as a general rule, by twentieths.

*Fourth.* Less than half of a note will not be redeemed, except by payment of the full value of the note under the second rule; or by payment of the proportional value of the missing part, when presented under the fifth rule.

*Fifth.* Fragments of notes, for which less than the full face value has been paid, will be retained for a year, to the end that the owners, who have received less than the value of a full note, may have opportunity to return the missing part, and receive the amount previously withheld.

*Sixth.* Until further order, mutilated notes and fragments will be redeemed only at the Treasury of the United States, at Washington; whither they can be sent, addressed to the "Treasurer of the United States," by mail, free of postage. A draft on the Assistant Treasurer, at New York, for the amount allowed, will be returned in the same way, to the address of the person remitting the same.

S. P. CHASE,

Secretary of the Treasury.

An extraordinary negotiation was now entered into by the Secretary of the Treasury, and one which produced much feeling among capitalists. The limit of demand notes, old and new, that might be issued under the loan was \$150,000,000. Of these \$60,000,000 were the old notes, receivable for customs, and which could not be reissued. There remained then authority to issue \$90,000,000 of new legal tender notes. As fast, however, as the old notes were paid in for customs, new ones might be issued in their place, and when the old notes should all be paid in the customs would be paid in gold only. These custom house notes were at  $1\frac{1}{2}$  per cent. premium, and the 3 year bonds, of which there remained \$29,000,000 still to issue, were at 3 per cent. premium. Under

these circumstances the Secretary, June 9th, being pressed for money, exchanged \$3,000,000 3 year bonds for \$3,000,000 old demand notes at 3 per cent. premium. In other words, he funded the old notes in  $7\frac{3}{4}$  3 year bonds. This transaction was a private one, and it was asserted that had it been public the Secretary could have obtained a much better bargain.

While these issues of paper had been pushed to such an extent in the service of the Government, the utmost reluctance existed on the part of Congress to impose necessary taxes, on the ground of such impositions being injurious to the political party making them. The tax law that had been levied, August 5th, 1861, and which was estimated to yield \$20,000,000, was repealed July 1st, 1862, in the following terms: "And be it further enacted, That so much of an act entitled 'an act to provide increased revenue from imports to pay interest on the public debt, and for other purposes,' approved August 5, 1861, as imposes a direct tax of twenty million dollars on the United States, shall be held to authorize the levy and collection of one tax to that amount; and no other tax shall be levied under and by virtue thereof until the 1st day of April, 1865, when the same shall be in full force and effect."

The objections to the tax were, that it would weigh heavily upon the western farmers. It was, however, evident that some tax must be imposed in order to maintain the credit of the Federal Government, and that tax was devised so as to give an apparent revenue to sustain the credit of the Government, while really it exacted nothing directly from agriculturists. The bill that with this object was introduced into the House, provided for taxes upon the profits of trade and industry, and upon the incomes of individuals. The profits are reached by stamps upon each transaction as expressed in any description of paper used in the transfer, and by a tax of 3 per cent. on all manufactures. The act imposing the taxes was very long and minute in its details. It was carefully reviewed and amended by the House in Committee of the Whole after it had been reported from the Committee of Ways and Means, and was first passed by that body on Friday, April 4th, 1862. It was then sent to the Senate, where it was referred to the Finance Committee, by whom it was in due time reported, with many amendments. The Senate, after long consideration, passed the act on Friday, June 6th, 1862, after having rejected two substitutes, offered respectively by Senators Simmons and McDougall. The act was then returned to the House for concurrence in the amendments made by the Senate, and referred to a conference committee of both houses. On their report it was finally passed June 23d, and received the signature of the President, July 1st, 1862.

The law by its terms was to go into operation on the 1st of September, but in consequence of the unavoidable delay in preparing

stamps, and the details of the inspectors, it did not go fully into operation until toward the close of the year. As a consequence, the penalties in respect to legal and other documents were remitted until after a suitable time. On the 17th of November the Commissioner issued the following notice:

TREASURY DEPARTMENT, OFFICE OF INTERNAL REVENUE,  
WASHINGTON, D. C., Nov. 17, 1862. }

The Commissioner of Internal Revenue is prepared to supply the following stamps in quantities sufficient for the use of the people of the District of Columbia, and of the States east of the Rocky Mountains, viz.: "Playing Cards," "proprietary," "express," "telegraph," "insurance," "life insurance," "fire and marine," "passage tickets," and "protest."

The use of the stamps herein specified is hereby required in the District and States above described, on and after the first day of December next; and persons guilty of wilfully neglecting to use said stamps will be subject to the penalty provided in the law.

GEO. S. BOUTWELL,  
Commissioner of Internal Revenue.

The following table shows the number and value of revenue stamps sold during the week ending Nov. 21st, by the Commissioner of Internal Revenue:

1 Cent Proprietary.....	2,199,500	\$21,895 00
1 Cent Express.....	1,690,000	16,900 00
1 Cent Playing Card.....	661,500	6,615 00
2 Cent Playing Card.....	795,000	15,900 00
3 Cent Bank Check.....	3,402,000	68,040 00
2 Cent Proprietary.....	2,751,000	55,020 00
8 Cent Telegraph.....	578,000	17,840 00
4 Cent Proprietary.....	689,750	21,590 00
5 Cent Express.....	221,000	11,050 00
10 Cent Contract.....	51,000	5,100 00
10 Cent Power of Attorney....	518,500	51,850 00
15 Cent Bill of Lading.....	510,000	51,000 00
15 Cent Inland Exchange.....	229,500	34,425 00
20 Cent Inland Exchange.....	284,600	46,920 00
25 Cent Life Insurance.....	102,000	25,500 00
25 Cent Bond.....	823,950	82,395 50
25 Cent Insurance.....	321,800	80,450 00
25 Cent Certificate.....	469,200	117,300 00
50 Cent Life Insurance.....	55,250	27,625 00
50 Cent Mortgage.....	267,750	133,875 00
50 Cent Original Process.....	84,000	17,000 00
50 Cent Probate of Will.....	255,000	127,500 00
50 Cent Conveyance.....	144,500	72,250 00
50 Cent Entry of Goods.....	131,750	65,875 00
50 Cent Passenger Ticket.....	190,625	95,312 50
50 Cent Bond.....	144,500	72,250 00
1 00 Conveyance.....	207,000	207,000 00
1 00 Power of Attorney.....	279,000	279,000 00
1 50 Inland Exchange.....	334,000	466,000 00
Herick's Dis.....	1,870	18 70
Total.....	18,561,045	\$2,217,178 70

These of course do not represent the number used in the week, but the supplies purchased for distribution and future use. The Assistant Treasurer of New York reported for the three last months of 1862 the receipts from internal revenues at that port. These were for October \$485,101, for November \$751,286, for December \$1,530,525; together \$2,725,912. These payments embraced the taxes, licenses, &c., payable under the law by dealers and professions in New York.

The principle of the law seems to be to tax capitalists, traders, and manufacturers, and as far as possible exempt agriculturists. This is, however, fallacious, since all the taxes, no matter by whom paid, fall ultimately fully upon the producers. The heads of taxation under the law are: stamps upon every species of paper

used to represent or transfer property; licenses for the practice of professions and commerce; taxes on dividends and profits; on incomes over \$600; on manufactures an ad valorem duty of 3 per cent., and a specific duty on others. In the imposition of this duty many exceptions in favor of agriculture are made. Thus cheese is not considered a manufacture; sugar from sorghum is not taxed, while sugar from cane is taxed. Under these various forms many persons are required to pay several taxes. Raw material, after leaving the hands of the farmer, is taxed at every new form it assumes until it gets back to him manufactured for consumption, charged with all the taxes with which it has been loaded on the way. Thus a cattle broker pays \$10 license and a stamp upon the receipt of sales. A calf slaughtered is taxed 5 cents, the skin is taxed 6 cents. The tanner pays 3 per cent. tax, and a stamp upon receipt of payment and upon check paid for skins. The leather dealer pays \$50 license, and for stamps upon receipts and checks. The shoemaker pays 3 per cent. tax, and for stamps upon receipts and checks. The wholesale shoe-dealer \$50 license and for stamps. The retail dealer \$10 license and for stamps, and the skins have come back to the farmer in the shape of a pair of boots loaded with 20 taxes besides his own income tax and those of the seven leading persons concerned in transforming the calf skin into boots, and returning it to the producer. All articles produced are loaded in the same way as they pass from hand to hand, and it results that the consumers of all products pay the whole of the tax accumulated upon them. The majority of consumers are agriculturists, and their productions are far in advance of the consumption of the Northern States. As a consequence they cannot charge upon their productions the weight of the taxes. The value of their crops, as a general thing, is governed by the markets abroad. The weight of the taxes has therefore a continued tendency to discourage consumption, and consequently production. This tendency is increased by the mode of levying; for example, some manufacturers are sworn 48 times in a month in relation to this operation. The whole amount of taxes advanced to the Government by employing manufacturers, is so much money directly abstracted from the capital required to prosecute industry. The census for 1860 states that in the Northern States the capital so employed is in round numbers \$900,000,000, and that it produces a value of \$1,700,000,000 per annum. The three per cent. charged upon this is \$51,000,000 per annum; but the stamps, licenses, income tax, &c., it is estimated, will raise the tax to be paid by those employers to 6 per cent., or over 100 million dollars—a sum drawn directly from their cash capital, which in this country has always been inadequate to the demand. The sum so withdrawn from the employment of industry is used by the Government in supporting troops who no longer

produce, but waste and destroy. The income tax is imposed for the year ending December 31st, 1862, and is charged upon all profits of business less \$600. Many sources of income, such as insurance, bank, and railroad stocks, bonds, &c., that pay the tax otherwise, are not included in the income charge. The tax is assessed May 1st in each year, ending December 31st previous, and is due and payable June 30th in each year until 1866, that is, for 5 years. This tax, it will be observed, is on profits of business, while the manufacturing tax of 3 per cent. is on gross production, irrespective of profits. The profits are deemed to be the actual net profits of the business, irrespective of individual or family expenses; but it does not necessarily follow that all business is conducted at a profit, and the means of evading this law are numerous. Nevertheless the Secretary estimated that it would yield \$150,000,000 per annum, and that with customs the amount would reach a sum equal to the ordinary expenditure, the interest on the debt, and a surplus for a sinking fund. The actual receipts from the taxes, except from corporations, salaries, and stamps, was, to January 3d, 1863, or five months, \$9,067,000 from twenty-four States.

The tariff was also deemed capable, notwithstanding the three revisions that it underwent in 1861, of yielding a larger revenue by raising the rates upon some articles; and it underwent such a modification as, it was estimated, would give \$100,000,000, which, added to the estimated \$150,000,000 to be derived from the internal taxes, would afford a sum sufficient to meet the ordinary expenses of the Government, the interest on the national debt, and afford a sinking fund for the ultimate redemption of the principal. This bill was passed and approved July 11th, 1862.

The expansion of the irredeemable paper currency produced its usual effect in causing coin to disappear altogether from circulation. The rise in the value of gold was followed by that of silver in proportion to its relative value as established by the law of 1852. That law grew out of the effects of the gold discoveries in California, which, at that time, it was apprehended would cause a depreciation of gold as compared with silver, and that as a consequence, in order to preserve the uniformity of values, and retain silver in the country, gold alone should be the legal standard, and the quantity of silver in the coins should be reduced. Accordingly the quantity of pure silver in the half and smaller fractions of the dollar was reduced nearly 10 per cent. below the standard, and silver was made a legal tender only to the extent of \$5. Under the operation of this law the Spanish fractions, which had formed the small currency since the settlement of the country, disappeared almost altogether, and the American coins became very abundant. Of these there had been coined nearly \$50,000,000 worth since 1852, and this amount circulated as well South and in California as North.

When the Government paper began to depreciate as compared with gold, silver also deteriorated, but in a lesser degree. The apparent premium on silver caused it to flow into the hands of the brokers, who were the reservoirs whence the exporters drew it to send out of the country. The express companies alone carried to Canada nearly \$4,000,000 within the year, and the people of Canada were sorely oppressed with the superabundance of this coin. The banks would not take it on deposit, nor would dealers receive it except at a discount of  $2\frac{1}{2}$  to 3 per cent. Thus south of the St. Lawrence a dollar bill was 20 per cent. discount for silver, and north of it a paper dollar bore 3 per cent. premium for silver. The swelling flood of paper in the States gave an increased impulse to the premium on silver. The profit so produced at once stopped the circulation of the coin. No one that received it paid it away, but hoarded it until a sufficient sum was accumulated to sell for the profit. The inconvenience was very great, and induced numbers of persons to buy change as high as 12 to 16 per cent. to pay out. This for a time retarded the depreciation of paper. Very many persons, however, availed themselves of the opportunity to issue small notes or "shinplasters," as they were popularly called. This custom had been very prevalent during the bank suspension of the years 1837-'8, when the same cause depreciated paper and drove out the specie. The manifold evils that flowed from that custom had caused in New York an enactment of which the following are sections, page 118, Revised Statutes, fourth edition, volume 2:

SEC. 6. No person, association of persons, or body corporate, except such bodies corporate as are expressly authorized by law, shall keep any office for the purpose of issuing any evidences of debt to be loaned or put in circulation as money; nor shall they issue any bills or promissory notes, or other evidences of debt as private bankers, for the purpose of loaning them or putting them in circulation as money, unless thereto specially authorized by law.

SEC. 7. Every person, and every corporation, and every member of a corporation, who shall contravene either of the provisions in the last section, or directly or indirectly assent to such violation, shall forfeit \$1,000.

Section 11, on page 119 of the same volume, forbids any person to pay, give, or receive in payment any bank notes issued by any banking company in this State of a less denomination than one dollar; and section 12 provides that the penalty for the violation of this provision shall be the forfeiture of the nominal amount of the note so received or paid.

This law being called to mind stopped the new issues of individual fractional notes, and there was a prospect that silver would be recalled.

In an evil hour, however, it was suggested that postage stamps might be used as a currency. The suggestion was promptly acted upon to the extent of many millions, and silver entirely disappeared. Those who had occasion purchased the stamps of the Post Office depart-

ment, and paid them out as change. An effort was made to restrain the use of them by selling only limited amounts to each individual. Congress then passed a law, in which stamps were prescribed as a medium of exchange in a great variety of transactions.

Be it enacted by the Senate and House of Representatives of the United States of America in Congress assembled, That the Secretary of the Treasury be, and he is hereby directed to furnish to the Assistant Treasurers, and such designated depositories of the United States as may be by him selected, in such sums as he may deem expedient, the postage and other stamps of the United States, to be exchanged by them, on application, for United States notes; and from and after the first day of August next, such stamps shall be receivable in payment of all dues to the United States less than five dollars, and shall be received in exchange for United States notes when presented to any Assistant Treasurer or any designated depository selected as aforesaid, in sums not less than five dollars.

SEC. 2. And be it further enacted, That from and after the first day of August, eighteen hundred and sixty-two, no private corporation, banking association, firm or individual, shall make, issue, circulate, or pay any note, check, memorandum, token, or other obligation, for a less sum than one dollar, intended to circulate as money, or to receive or use in lieu of lawful money of the United States; and every person so offending shall, on conviction thereof in any district or circuit court of the United States, be punished by fine not exceeding five hundred dollars, or by imprisonment not exceeding six months, or by both, at the option of the court.

Approved July 17, 1862.

In order to extend the small currency, which was popular for the moment, on the passage of this act, the following notice was issued:

The undersigned respectfully inform the public that after the 1st of August, motives of commercial expediency, as well as of official duty, will compel prompt prosecutions for any issue of paper commonly called "Shinplasters"—should such an issue exist, after the recent Act of Congress shall have afforded an uniform substitute for "small change."

The collection of the State penalties or the Federal fines can be rigidly enforced by due process of arrest.

E. DELAFIELD SMITH,  
United States District Attorney.

A. OAKLEY HALL,  
District Attorney City and County of New York.

The Supreme Court of the State of New York, however, in the month of October, pronounced this law of Congress in relation to "shinplasters," unconstitutional.

This act of Congress simply allowed the stamps, both internal tax and those for postage, to be used as a currency, directing the Secretary of the Treasury to furnish them for that purpose, and directing the "Assistant Treasurer," irrespective of the Secretary, to redeem them in sums of \$5 when presented, after August 1, 1862. The stamp currency is not a legal tender between individuals, but only for Government-dues, and is convertible into legal tender money. On the 1st of December \$3,884,800 of this new currency had been issued. Instead of following the law, the Secretary of the Treasury caused to be prepared a new small currency, in no way like the stamps authorized, and caused them to be issued without any limit as to amount, at the same time directing the

Assistant Treasurers to disregard the law directing them to redeem the postage stamps used as a currency. This order did not absolve the Assistant Treasurers from obedience to the law which they violated. They not only refused to redeem the stamps, but the Postmaster repudiated them also. This inflicted a grievous wrong upon the people, who held millions of the worn and dilapidated stamps. The popular will ultimately compelled the Postmaster to issue a notice that they would be redeemed under certain regulations. Under this notice large amounts were redeemed.

The amount of small currency issued by the Treasury department to December 1st, was \$3,884,800, and the Secretary proposed to push it to \$40,000,000.

Meanwhile the resources of the Treasury were exhausted, and however fully these tax bills might come up to the estimates, it was evident that they could afford no immediate supply. Hence a new loan bill was matured in Congress. It provided that the limit on the amount of deposits that might be received at the Treasury should be raised from 50 to 100 millions, and that \$150,000,000 more of legal tender notes might be issued. Of these \$35,000,000 might be of a denomination less than \$5, but not less than \$1. Of the whole amount \$50,000,000 should be reserved to pay the deposits when demanded. This was inserted in the Senate on the passage of the bill at \$75,000,000, but was finally fixed at \$50,000,000 by a committee of conference. This singular provision was in effect paying 4 per cent. for money to keep on hand idle. Since the demand notes being created and only applicable to the payment of that amount of deposits held by the Government, the mere act of paying them out would not only save \$2,000,000 paid for interest on those deposits, but would so increase the supply of money in the market as to promote the general rise of values. The act also permitted the deposits to be funded in 5-20 year bonds. The following is a synopsis of the act passed July 11th, 1862:

1. That the Secretary may issue, in addition to amounts before authorized, notes to the value of \$150,000,000.
2. That no notes for a fractional part of a dollar shall be issued, but that of the above named sum \$35,000,000 shall be of lower denominations than \$5.
3. That such notes shall be receivable for all debts due to or from the United States, with the exception of duties on imports and interest on bonds, notes, &c., and shall be a legal tender.
4. That certificates of deposit may be issued, bearing interest at the rate of six per cent. payable semi-annually.
5. The Secretary may exchange for such notes, on terms deemed by him most beneficial, United States bonds bearing six per cent. interest, redeemable after five and payable in twenty years; may issue notes so received in exchange; may receive and cancel notes issued under former acts, issuing in lieu thereof an equal amount in notes authorized by this act, and may purchase, at rates not exceeding that of the current market, and cost of purchase not exceeding one eighth of one per centum, any bonds or certificates of debt of the United States he may deem desirable.

6. That the engraving, &c., may be executed at the Treasury Department.

7. That the limit of receipts of temporary deposits be extended from \$50,000,000 to \$100,000,000, the interest, as heretofore, not to exceed five per cent.

8. That no less than \$50,000,000 of the notes to be issued shall be reserved for payment of such deposits.

9. That certificates of deposit and indebtedness may be received on the same terms as United States notes for bonds redeemable after five and payable in twenty years.

10. That the Secretary may, until otherwise ordered by Congress, borrow such part of the sum of \$250,000,000 (which he was authorized to borrow by the "Act to authorize a national loan, and for other purposes") as may not have been borrowed within twelve months of the time of its passage.

Under these various laws the resources of the Secretary were now apparently as follows: additional deposits, 50 millions; notes, 100 millions; 1 year 6 per cent. certificates, unlimited probable issue, 50 millions; small currency, no limit, probable issue, 80 millions;  $7\frac{3}{4}$  three year bonds still on hand, 30 millions; 5-20 year 6 per cent. bonds, 500 millions, probable issue 30 millions. These together gave a round sum of \$290,000,000, which added to the estimate of the taxes, 210 millions, made \$500,000,000 for the resources of the Treasury until Congress should again meet. These resources were voted, however, on the estimate of expenditure, based upon the then state of military affairs, which soon changed in a manner to compel the Government to call out 600,000 new troops at a heavy cost of bounty, equipments, transportation, &c., in addition to the vast supplies lost to the enemy, and which required to be promptly replaced. In other words, the expenses were increased 150 per cent., and the pressure for money to move the troops greater than ever. The time required to print the new notes caused much delay, and the Secretary could serve himself only with deposits, the 1 year certificates and the  $7\frac{3}{4}$  bonds, while the pay of the army and contractors went heavily in arrears. He was compelled to economize the legal tender notes as much as possible, since the small balance on hand, and those which came in through deposits, were the only money means at his disposal. He, therefore, paid out  $7\frac{3}{4}$  bonds and 1 year certificates to creditors, giving them a proportion in notes. Generally disbursing officers' checks were paid 25 per cent. in notes, and 75 per cent. in 1 year certificates. The latter being put upon the market by those who received them, sank below par. When they were originally issued the interest was intended to be paid on them at the end of the year. As they fell in price, however, under the amounts put in the market by the Government creditors, it was necessary to do something to sustain them, and notice was issued that the interest would be paid at the end of six months in gold. This for a while supported the price, but the Secretary was compelled soon to cease paying out notes altogether. They became then the only medium for the discharge of claims, and fell in price. Meantime there was some disposition on the part of the public

to convert notes into 5-20 year bonds. The general idea prevailing that the Government had embarked on a system of paper money, which would lead to its discredit, and be represented by a general rise in every description of property, naturally produced a disposition to purchase and hold property to avail of that inevitable rise. This speculative feeling at first attached to such articles as could most readily be held and disposed of, and such as were not in superabundant supply. Gold, stocks, all metals, and many articles of merchandise, became the objects of speculation, which aided the rise in prices caused by the excess of paper. It was charged on one side that the whole rise was caused by the speculation, and on the other that it was all caused by the depreciation of paper. The fact seems to have been between those opinions. The paper caused the rise, and the knowledge that such would be the inevitable tendency of the Government money, induced speculators to avail of the knowledge and purchase. Their operations caused prices to rise much higher than they otherwise would have done. Gold particularly was a favorite investment. It was very easily purchased, required no handling, was readily loaned upon by the banks, and could be converted at a moment's notice. Moreover, it was known that the foreign demand was equal to  $1\frac{1}{2}$  millions per week, which was rapidly reducing the quantity at command. The existing laws also required the Government to pay interest in coin, and also required merchants to pay customs in gold. If the customs under the new tariff should reach the estimates of the Secretary, 100 millions per annum, the importers would, after the outstanding old demand notes were absorbed, be required to buy two millions of gold per week. This joint demand would require to supply it at least three millions per week, and the active continued demand would necessarily raise it to an exorbitant price. It was argued that the Government would pay out the gold received from the customs, and, therefore, resupply the market; but a little reflection showed that those who received it would not give it away, but would reserve it for the higher premium that the continued issue of paper on one hand, and the demand for gold on the other would inevitably bring about. The banks found a safe and profitable investment in lending on the gold, but the holders of gold or of other articles could draw no interest on the funds thus employed. They would depend on the rise in price for their profits. At this juncture the Government being in want of gold, which was 20 per cent. premium, to pay the \$1,875,000 interest maturing on the 50 millions of  $7\frac{3}{8}$  notes August 19th, came forward and proposed to take gold on deposit, returnable in kind at 10 days' notice, and allow 4 per cent. interest. This at once drove speculation into gold. It was a premium of 4 per cent. interest to hold gold instead of copper or tin, or pork, or other articles for a rise. The price

immediately rose, and ran up to 89 premium at the close of October. Inasmuch as gold governs the price of exchange, bills ran up in the same proportion, and sterling bills which are par at  $109\frac{1}{2}$  touched 152. The effect of this was to add 40 per cent. to all remittances out of the country. It added 40 per cent. to the cost of importations, which caused them to decline, and with them the customs revenue of the Government, which found 40 per cent. added to all that it had to pay abroad. The salaries of ministers, navy expenses, &c., were all increased 40 per cent. The Secretary, alarmed, sought to stop the speculation in gold, which he deemed to be the cause of the evil, and to that end sent on an agent to New York to solicit the banks not to lend on gold, and the Board of Brokers not to deal in it. Some of the banks complied, and the result was that their depositors drew the money and lent it individually upon gold. They thus lost the business without reaching the end desired. The Board of Brokers had the weakness to do the same thing, and struck gold from the list of articles dealt in. The effect was that gold was dealt in outside the board, and while the amount of transaction was no less, the brokers lost their commissions. They endured this nearly three weeks, and then, Nov. 16th, not only restored gold to the list, but permitted time operations in it. An effort was then made by free sales for future delivery at lower rates, to break the supposed speculation, and reduce the price. The sales so made were freely taken for export at the expense of the operators for the fall, and prices rose.

Following the rise in gold, the prices of stocks also advanced, and reached very high figures, and these developed some disposition to convert notes into the 6 per cent. 5-20 stock at par. At that juncture, however, October 27th, the Secretary thought proper to make inquiries in relation to the terms on which he could negotiate that stock in the market. As by the terms of the law the notes may at all times be converted into the stock at par, it follows that the stock would never sell higher than that. Any terms proposed must, therefore, necessarily be below par, and the limit of such an operation at once stopped conversions. Meantime the Secretary had since June 1st paid out about \$17,000,000  $7\frac{3}{8}$  bonds to creditors and others, and there remained on hand \$13,420,550. On the 10th of November he issued a notice for proposals to be opened in 6 days for these bonds, the bidder to deposit 10 per cent. of the amount with the Assistant Treasurer—the bonds to date from the day of deposit. This notice appeared Monday, November 10th; on the next day Mr. Chase asked the banks for a temporary loan of 12 millions, at 5 per cent., in anticipation of the proceeds of the loan thus advertised. The money was promptly advanced to him, but to do so money was called in, causing stocks to fall about 2 per cent., and the rate of money to rise 1 per cent. This most

extraordinary operation produced the greatest surprise. It will be borne in mind that the Secretary had these notes on hand more than one year, and then suddenly offered them at 6 days' notice, and then not being able to wait even that six days for his money, borrowed it in a manner to raise the rate of money in the market against his own operation. The loan sold for less than it would have done had not the Secretary thus wantonly disturbed the market. Of the 12 millions asked for 10 were taken in New York, one in Boston, and one in Philadelphia. It now appeared that the Secretary was alarmed; he had borrowed the money of the banks to pay back in 6 days, and he was dependent upon the loan to enable him to keep his contract. If now the parties to the loan took advantage of the position, they might dictate such terms for the loan as they thought proper. To avoid this danger, the Secretary put all the printing presses in his employ to running upon large denominations of demand notes, by which he might be able to manufacture enough to meet the temporary loan if the 7½ should not be taken. The bids were however opened on the 17th of November, and it was found that in all \$29,994,350 had been offered at rates varying from par to 4½ premium. The lowest offers came in from Massachusetts. It resulted that \$350,000 were allowed to Boston at 3½ to 4 per cent. About \$1,000,000 to Philadelphia at 3.10 to 4½ per cent.; \$1,200,000 to Washington, at 3.05 to 4 per cent., and the remainder to New York, at 3.05 to 4.05 per cent. All bids above 3.05 amounted to \$9,505,050, and were accepted, and those who bid 3.05 got 59½ per cent. of this offer. The Secretary, in alluding to this transaction in his annual report, stated that the takers of the loan found difficulty in obtaining United States notes to make the payments to the Treasury, and inferred from this that there was not currency enough. The fact seems to have been otherwise. The banks had deposited \$35,000,000 of legal tender notes at the sub-Treasury for 5 per cent. certificates. These certificates were at first used to settle balances at the clearing house, but as legal tender notes accumulated in the banks, they preferred to pay balances in those notes rather than in certificates bearing interest. For this purpose some 12 millions were in use, making 45 millions of notes held by the banks. When the Secretary came forward for his 12 millions advance at 24 hours' notice, a further demand was created, and when the loan was taken on the 6th day, \$13,613,340 more of notes were required to be paid in before the 12 millions lent could be returned. The transaction therefore required \$25,613,340 to perfect it in addition to 12 millions used for balance, and \$35,000,000 on deposit with the department. Thus the banks were called upon for 72 millions of the notes, and at the same time some of the banks that, by reason of their expanded condition, were short in their balances at the clearing house, were borrowers of the other banks. Yet the whole

transaction would have passed off without disturbing the markets, had the Secretary not in effect demanded two loans when only one was wanted. The whole amount of notes outstanding was about 200 millions, and the New York banks manipulated one third of the whole amount.

The annual report of the Secretary at the opening of Congress gave the following statement of the revenues and expenditures of the Government for the fiscal year ending June 30th, 1862:

*Receipts and Expenditures for the fiscal year ending June 30, 1862.*

RECEIPTS.	
The total receipts, including a balance on hand July 1, 1861, of \$2,257,065 80 were \$588,885,247 06, as follows:	
From customs.....	\$49,056,597 03
From lands.....	152,208 77
From miscellaneous sources.....	981,737 64
From direct tax.....	1,795,831 73—
From loans:	\$51,985,720 76
Bonds, 8 years, 7.30 per cent.....	122,087,585 24
5-30 years, 6 per cent.....	13,990,800 00
Oregon war.....	1,000,700 00
20 years' 6 per cent. at par, for \$50,000,000, 7 per cent.....	44,268,129 17
Treasury notes, 3 years, act of June 22, 1860, and March 2, 1861.....	14,019,084 66
60 days, act of March 2, 1861	12,896,850 00
Acts of Feb. 8 and March 2, 1861.....	2,500 00
Act of Feb. 8, 1861.....	55,257 50
Currency notes, acts of July 17 and Aug. 5, 1861, and Feb. 12, 1862.....	60,080,000 00
Act of Feb. 25, 1862.....	98,620,000 00
Temporary loan, act of Feb. 25, 1862.....	66,479,824 10
Certificates of indebtedness, 1 year, acts of March 1 and 17, 1862.....	49,861,979 73
Temporary loan, in anticipation of popular subscription.....	44,375,000 00—
Aggregate receipts.....	\$581,693,181 26
Balance in treasury.....	2,257,065 80
<b>Total resources.....</b>	<b>\$588,885,247 06</b>
EXPENDITURES.	
Civil and foreign intercourse.....	\$31,408,491 16
Pensions and Indians.....	8,102,985 50
War department.....	894,868,407 26
Navy department.....	42,674,569 00
Interest on public debt.....	18,190,824 45
Total current expenditure.....	\$474,744,778 16
Redeemed old debt.....	104 56
Redeemed treasury notes of 1867, 1860, 1861.....	48,110,000 00
Redeemed temporary loans.....	44,375,000 00
Redeemed temporary loans, Feb. and March, 1862.....	2,552,207 58
Redeemed notes, July 17, '61.....	58,610 00—
Total expenditure.....	\$670,841,700 25
Balance in treasury, July 1, 1862.....	13,043,548 81
<b>Total.....</b>	<b>\$588,885,247 06</b>

This represented the actual expenditure of the first year of the war, but did not embrace all the cost, since very large claims remained unpaid. The money paid out, irrespective of the debt repaid, was \$1,300,000 per day average. With the close of that year, however, the number of troops in the field and the operations of the Government assumed greater scope, causing the estimates for 1862 to be more than double the expenditures of 1862, as follows:



	RECEIPTS.	Actual, 1862.	Estimates, 1862.
Customs, &c. ....		\$50,140,839 08	\$70,874,777 07
Taxes.....		1,795,831 78	11,620,717 99
Internal taxes.....		.....	85,456,908 78
<b>Total receipts.....</b>		<b>\$51,935,790 76</b>	<b>\$167,451,798 79</b>
	EXPENSES.	Actual, 1862.	Estimates, 1862.
Civil, foreign, &c. ....		\$21,408,491 16	\$22,811,548 28
Pensions and Indians.....		3,102,985 50	5,922,906 48
War.....		394,368,407 24	747,850,898 98
Navy.....		42,674,569 09	52,177,610 77
Interest on debt.....		13,190,824 45	25,014,583 07
<b>Total expenses.....</b>		<b>\$474,744,778 16</b>	<b>\$698,846,291 48</b>
Excess of expenses.....		422,809,087 40	735,894,528 60
Debt June 30.....		517,372,802 98	1,122,297,403 24

These estimates for the new year do not embrace contingences that may arise from unforeseen disaster nor any payments on account of the principal of the public debt, of which a large amount falls due and must necessarily be provided for in other loans.

The debt of the United States, as expressed in the evidences outstanding at the close of the year as compared with that of the corresponding period of the two previous years, was as follows:

DEBT OF THE UNITED STATES ON JANUARY 1, 1861, 1862, AND 1863.

CLASS.	Rate.	1861.	1862.	1863.
Loan of 1842 .....	6	\$2,888,864 11	\$2,888,864 11	Paid.
" 1847 .....	6	9,415,250 00	9,415,250 00	\$9,415,250 00
" 1848 .....	6	8,908,841 80	8,908,841 80	8,908,841 80
" 1858 .....	6	20,000,000 00	20,000,000 00	20,000,000 00
" 1860 .....	5	7,022,000 00	7,022,000 00	7,022,000 00
" February, 1861.....	6	.....	18,415,000 00	18,415,000 00
" July, 1861.....	6	.....	50,000,000 00	50,000,000 00
Loan, payable from five to twenty years.....	6	.....	.....	25,050,850 00
Texan debt .....	5	3,461,000 00	3,461,000 00	3,578,092 00
Oregon debt.....	6	.....	307,900 00	1,026,600 00
Three years' bonds.....	7 <sup>3</sup> / <sub>10</sub>	.....	100,000,000 00	150,000,000 00
Treasury notes, old.....	6	7,387,011 64	769,311 64	104,561 64
" December, 1860.....	10 @ 12	10,000,000 00	9,993,950 00	221,650 00
" temporary .....	6	.....	3,998,900 00	111,600 00
" two years.....	6	.....	7,767,600 00	2,750,850 00
One year's certificates.....	6	.....	.....	110,321,241 65
Deposits.....	4	.....	.....	38,468,008 50
" .....	5	.....	.....	41,777,628 16
Demand notes, July, 1861.....	.....	.....	50,000,000 00	10,000,000 00
" February, 1862.....	.....	.....	.....	4,913,315 25
" March, 1862.....	.....	.....	.....	123,108,000 00
" July, 1862.....	.....	.....	.....	100,000,000 00
Fractional currency.....	.....	.....	.....	6,844,936 00
<b>Total debt.....</b>		<b>\$89,076,967 55</b>	<b>\$292,987,617 55</b>	<b>\$721,668,727 59</b>
Add army arrears.....		.....	.....	59,117,597 46
<b>Total.....</b>				<b>\$780,786,325 05</b>

The debt at the close of 1860 expressed the remains of former loans growing out of the Mexican war and the emission of treasury notes caused by the financial revulsion of 1857, which diminished the customs' revenue. The 10 millions of treasury notes issued in December, 1860, were to meet the deficit at that time, and were negotiated at 10-12 per cent. interest. Those notes have been mostly paid off in paper money in order to stop that high rate of interest. The various denominations of issues made during the war are expressed under each head, and the result is an amount of, in round numbers, 750 millions of outstanding paper on January 1st, 1863. This does not express the whole debt, however. There were then many months in arrears of pay for the whole army, and claims of contractors and others were for several large sums. The issues for the year 1862 were nearly altogether paper money and temporary loans. There was paid off January 1st, 1863, the remains of the old 20 years' 6 per cent. stocks of 1862 under peculiar circumstances. The high rate of gold made it probable that the principal would be paid in Government paper, but there were some intimations that it would be paid in gold; the stocks were therefore of a highly speculative value. If paid in paper the amount of the debt

paid was \$2,833,864.11; if paid in gold at 83 per cent. premium, the holders would realize \$3,763,374.26, an apparent profit of \$935,010. There was no authority to buy the gold with which to pay the debt. It was, however, obvious that unless the Government that had received gold should pay in gold, its credit would be seriously damaged. To support the Government credit, therefore, certain of the banks agreed to lend to the Treasury at 4 per cent. sufficient gold to pay the debt, the gold to be returned to the banks when the Government should be in receipt of the gold through the customs. By this means the banks obtained 4 per cent. interest on gold otherwise idle, and would receive it back when its value would be much enhanced by the operations of the importers.

In relation to the loans in his annual report, the Secretary remarked as follows:

It has been the care of the Secretary to reduce the cost of the debt, in the form of interest, to the lowest possible amount, and it is a source of real satisfaction to him that he has been able, thus far, to confine it within very moderate limits. The first loans, being of a magnitude hitherto undreamed of in our market, were necessarily made at an interest which he regarded as high, though lenders strenuously insisted on higher; but large amounts are now obtained at five and four per cent., while the circulation of United

States notes constitutes practically a loan from the people to their Government without interest. The average rate on the whole loan is thus reduced to  $4\frac{1}{2}$  per cent.

These statements were very extraordinary under the circumstances since, although the amount to be paid out by the department as interest was small, yet the people paid the most ruinous rates of interest. The first loans contracted by the Secretary were in 6 per cent. stocks at 85, or  $7\frac{1}{2}$  per cent. nearly. The next loans were in  $7\frac{1}{2}$  per cent. bonds, and the interest began to run long before he drew the money, giving an advantage equal to 10 per cent. to the lenders. The next loan was at 7 per cent. on the same terms, viz.: to pay interest before he received the money. Loans were then no longer possible, but creditors were compelled to take  $7\frac{1}{2}$  per cent. bonds for their claims, and they sold as low as 96, losing 4 per cent. and the buyer getting  $8\frac{1}{2}$  per cent. for his money. One year's 6 per cent. certificates were then paid out and sold as low as 95, giving 11 per cent. for the investment in a year. The legal tender currency was then paid out at par and depreciated gradually until it reached at one time nearly 40 per cent. This depreciation represented the tax to which the public is subjected through the use of that paper. The Government itself paid in the enhanced rate of exchange a large sum. The payments abroad for diplomatic salaries and the use of the Navy are nearly \$10,000,000 per annum. To make these remittances the Government was at one time compelled to pay 152 per cent., or 42 per cent. above par, which on the remittances amounted to \$4,200,000 actually paid out in consequence of the paper depreciation. In like manner the price of all supplies and munitions is enhanced by the depreciation. If of the whole expenditure of the army \$120,000,000 is for pay of the troops, being \$18 per month for 800,000 men, there remain \$680,000,000 for supplies, transportation, &c., the rates of which are enhanced with the price of gold, and at the present rate, 80 per cent., the extra cost to the Government by the use of paper is \$180,000,000 per annum, a sum nearly equal to the amount of notes outstanding. So fearful an expense is hardly matter of congratulation that the Secretary borrows "without interest." The pay of the soldiers is diminished in the same proportion, since through the rise in prices, \$18 will this year purchase no more than would \$10 last year; hence a motion was made in Congress to raise the pay of the troops to \$15 per month. The fact was apparent that in the 18 months ending July, 1864, the Government would require \$1,000,000,000 in addition to \$300,000,000 of existing loans that would fall due, and not taking into account reclamations, damages, and disasters that must arise, and allowing for the extra allowances that must necessarily follow the use of paper money. The \$100,000,000 of 3 years' bonds would fall due, as much one year's certificates, or a like sum in

deposits, and a sum not less than \$1,500,000,000 would be required.

The amount of capital which can be permanently loaned to the Government consists only in a portion of the surplus profits earned each year by the pursuits of industry, and which each man can spare out of the operations of his business. It is only within the last twenty years that surplus capital has very rapidly accumulated, but it has been in active demand for investment in the many enterprises that have been undertaken of a permanent character. Of these railroads are the most conspicuous, and they have absorbed nearly \$1,000,000,000 since 1850. The real amount of surplus capital that accumulates each year is difficult to determine, but the late census affords some data on which to approximate a result. It is there stated that the annual productions of industry are in value \$1,900,000,000 per annum, or, in round numbers, \$2,000,000,000. This sum expresses the labor and capital expended in producing all those articles which enter into commerce and the maintenance of the people. If this value is produced, nearly as much is expended or consumed in the operation—in some years quite as much; as in years of bad harvest there is probably no more capital in existence at the end of the year than when it commenced. Taking one year with another, however, the actual income may be 10 per cent. or \$200,000,000; of this a large portion goes to extending business, improving land, constructing houses, &c., and there may remain \$100,000,000 which may be invested permanently by the owners to draw interest. These investments have greatly increased of late years, and may be approximated as follows:

State, city, and county stocks.....	\$350,000,000
Railroad capital.....	800,000,000
“ “ bonds.....	700,000,000
Bank capital.....	421,880,000
Insurance, mines, &c., &c.....	250,000,000
Savings bank deposits.....	900,000,000
Bonds and mortgages.....	150,000,000
Total invested capital.....	\$3,371,880,000
Capital per census employed in industry..	1,000,000,000
Total.....	\$3,371,880,000

The vast undeveloped resources of this country, with the supply of labor by immigration, and the immense wealth in new lands, cause the demand for capital constantly to outrun supply. Hence all active men are borrowers of capital; but if a number of persons engaged in business enterprises were to realize this capital, and invest it in the Government stocks, the productive industry of the country would to the extent of such transactions be stopped, and the source of national wealth be dried up. This is a course of proceeding, which all prudent statesmen carefully avoid. It is to be remarked that the accumulation of capital in this country has heretofore been rapid, for the reason, among others, that the taxes have been very light. There have been no vast sums expended upon military idlers. This is now changed, and under the existing laws it is es-

timated that the taxes will reach \$250,000,000 per annum—a sum more than equal to the whole supposed annual surplus profits of the national industry heretofore. This at once checks accumulation. In addition to this 1,000,000 men, before producers, have been taken from productive industry, and have become consumers and destroyers. The effects of these two circumstances are making themselves felt in the diminished profits of investments, or, in other words, falling values. It is apparent that the huge sums demanded by the Secretary cannot be obtained on loans without stopping the industry of the country, on one hand, or destroying values on the other. To obtain means by the issue of paper money has a still more disastrous effect, since it takes from every man a portion of his earnings and values. The munitions and supplies that the Government obtains in return for paper issues are at continually higher prices. In other words, more paper must be given for the same quantities at each succeeding purchase, and this in the double ratio of greater supplies of paper and diminished production of the commodities. Very speedily the purchasing power of the paper ceases, and although by virtue of its power of legal tender holders of maturing obligations may be ruined, it will no longer command any of the necessaries of life.

The number of those who can spare capital out of their regular business to place at interest is small. The estates of minors and others increase to some extent, and those funds seek investments. If the whole 2,100 millions, exclusive of savings deposited, draw 5 per cent. interest, the result is 100 millions of interest paid annually by industry. The capital invested in productive industry may pay 10 per cent. or 100 millions more. These two items absorbed nearly all the capital there is in the country, since no one allows any considerable sum to lie idle or unproductive. The Government now steps forward and for war purposes demands in two years, ending January, 1864, \$1,500,000,000, or more than one half of all the capital invested in industry and in securities. This is a serious

demand, and it is at once evident that it cannot be complied with except by drawing the amount out of other occupations. If its credit remains unshaken, and the public consider its promise as good as the best security, then it must offer such terms to lenders as will induce them to change their investments. To invest largely in Government they must sell New York or Ohio, or bank stock, or railroad bonds, or such as they hold, in order to make the purchase. But it is obvious that extensive sales cannot be made for want of buyers. If the holders of the above named 2,000 millions of securities all wanted to sell, it is clear there would be no buyers. If a large proportion wished to sell they could find buyers only at low prices, and the general level of prices would be proportioned to the extent of the conversions. Hence it is evident that the Government could obtain its loan only at such rates as would outbid all the borrowers. If all the surplus capital is now equal to 2,000 millions, represented by the amount of stocks at par, then to add 1,700 millions to the quantity of stock, would cause the whole mass of stock to fall to 55 per cent. to represent the same capital, 2,000 millions. This is under the supposition that the Federal credit would remain equal to the other stocks. It is, however, not equal to them, but is now much below that of the individual Northern States.

The state of affairs now produced the greatest anxieties in the public. It became evident that to pursue this paper system was to invite bankruptcy and repudiation, and numerous representations were forwarded to Washington to remonstrate against the further issue of paper. On the other hand there were those who equally dreaded the collapse in value which must result from the placing of large loans upon the market. The Government stocks were nearly at par for paper, but were far below par as measured with specie, which would become the measure of value on abandoning paper. The following table represents the effect of the currency measures of the Government during the year upon stocks, the metals, and trade:

Months.	Imports.	Exports.		Silver to Canada.	Sterling.	Gold.	Silver.	Notes.	20 years 6 per cent.	13 years 10 per cent.	1 year 6 per cent.
		Goods.	Gold.								
January.....	\$12,690,899	\$12,289,968	\$2,658,874	\$124,081	110½	2 @ 5	..	Pr.	88	99	..
February.....	18,873,140	10,885,924	8,776,919	96,000	118	2½ @ 4½	..	"	98	99½	..
March.....	18,719,866	9,509,431	2,471,288	9,879	119	1½ @ 2½	..	"	98	99½	96½
April.....	18,292,889	8,666,199	4,087,675	109,100	111½	1½ @ 2½	..	"	108	104	99½
May.....	19,948,516	10,177,561	5,164,586	4,515	119½	2½ @ 8½	..	½	106½	106½	100
June.....	12,386,195	10,464,761	9,867,614	165,343	121	2½ @ 9½	1	½	108	106	100½
July.....	20,258,202	15,697,578	8,067,887	189,089	181	9 @ 20	9	5½	98½	102½	98½
August.....	14,804,848	14,190,169	8,718,583	488,044	128	12½ @ 16½	10	8	99½	108½	99
September.....	18,147,917	15,975,552	3,035,719	444,490	181	16 @ 19½	18	29½	104½	105½	94
October.....	18,418,906	20,312,597	6,707,519	673,741	159	29½ @ 39	28	26	104½	106½	99
November.....	10,809,898	14,890,681	6,218,251	786,185	147	28½ @ 38	26	25	104	104	97½
December.....	18,072,618	15,266,508	8,678,119	891,240	147½	8½ @ 34	26	26½	96½	101½	96½
1863.....	\$174,652,317		\$59,487,091								
1861.....	162,768,790		4,286,250								

The first column represents the value of goods imported into the port of New York, the second column the value of merchandise export-

ed, the third column the amount of gold exported from New York, and the fourth the quantity of silver carried to Canada monthly by one

express company. Then follow in order the prices of sterling exchange, the price of gold in paper, the price of silver, United States notes receivable for duties, and of the Government stock. The year opened with a reaction in respect to the "balance of trade," on the large imports of specie that were made in 1861, as a consequence of the sudden stoppage of importations of goods in that year, and exchange was nearly par at that time; the currency was then nearly on a specie basis. A suspension of specie payments had indeed taken place, but the banks were thus put within the penalties of the law, and had reduced their circulation, in the effort to resume as soon as possible. Specie did not therefore rise in value, and the Government 6 per cent. stocks were at about par for a 7 per cent. stock, and money in the open market was not abundant, and specie did not rise in price. The moderate importations of goods in the previous year had caused a diminution of stocks on hand, and the progress of the armies of the West had encouraged the hope of larger sales, while there were fears of higher duties to be imposed by Congress, which therefore promoted importations, that became considerable in March, causing an outward flow of specie, which began to rise in premium in April, when the legal tender notes of the Government made their appearance. From that moment the metals, exchange, and old demand notes receivable for customs steadily appreciated, while gold flowed in a broader stream out of the country. The passage of the legal tender bill in Congress had alarmed foreign holders of stocks, and these were sent to New York for realization in considerable quantities, the proceeds to be remitted in specie. The imports of goods that had again become small in June suddenly rose in July, in anticipation of a new tariff, and the hope that the advance in prices under the influence of paper would prove remunerative. For the same reason the exports increased, because the rise in exchange favored the shipping of goods. Those months in which the largest exports took place are those in which the rates of exchange ruled highest. A barrel of flour that sold in Liverpool at 22s. 6d. in January, would at 10 per cent. exchange realize to the shipper \$5.50 in exchange. At the same price for flour, when exchange in July rose to 130, the shipper got \$6.50 for his bill, and in October, when exchange reached 150, he got \$7.50 for his bill. Thus the rise on exchange for the time was equal to an advance abroad for the produce, but this movement soon produced a rise in prices which counteracted the exchange, and shipments fell off rapidly in the last two months. It is to be borne in mind that the import values are the specie invoice prices, and the sum represents the amount to be paid in specie; on the other hand the exports are home values in paper money, and represent a sum larger by the depreciation of the paper than will be actually received. Thus in the month of November

gold was at 138 premium, or the paper was depreciated 25 per cent., hence the \$14,390,681 of goods exported would realize in specie only \$10,793,011 abroad. The aggregate of the exports for the year by no means therefore represents the amount that can be applied to the payment of goods, and the amount exported declined. Toward the close of the year the rise in paper prices here was to some extent counteracted by the decline in prices of western produce abroad.

The imports on the other had suffered a grievous burden; first in the higher duties, second in the high premium on gold, or gold notes, which were the only medium for the payment of duties, and third, on the rise of bills. An illustration is afforded in comparing the imports of any month, November for instance, with the same month of the previous year, as follows:

	1861.	
Goods, duty paid.....	.....	\$7,765,543
Duties, 24 per cent.....	\$1,858,834	....
Gold, par.....	.....	....
Exchange, par.....	.....	....
Total, 24 per cent.....	\$1,858,834	....

	1862.	
Goods, duty paid.....	.....	\$8,678,194
Duties, 24 per cent.....	\$8,008,370	....
Notes, 25 per cent.....	750,917	....
Exchange, 35 per cent. advance	3,085,617	....
Total, 30 per cent.....	\$8,789,704	....

Thus the average expense of landing goods this year in November was 80 per cent., against 24 per cent. same time last year. This advance was very onerous, and exceeded the rise which took place in the markets of sale, subjecting the importers to loss; as a consequence the importations declined. The mere rise in the cost of importations was not the greatest evil encountered, since none could tell what the cost of landing goods already ordered might be. If the Government continued to emit paper money while it exacted duties in gold, the cost of importation would rapidly rise, and when goods arrived the expenses of entry might be 20 or 30 per cent. higher than when the goods were ordered. This was an evil against which no calculations could guard, and importations became a mere lottery. The time was approaching also when the old demand notes would all be absorbed, and the duties would then be payable in gold, which would involve an active demand for that article on the part of importers to the extent of \$3,000,000 per month.

While all these radical changes were taking place in the condition of trade, the table on the preceding page indicates that Government stocks did not rise in any degree proportionate to other articles. Thus in January the 8-year bonds, which bear 7.80 interest, payable in gold, sold at 99 for specie; in December the price of the same bonds was 101½ for paper, 76½ for specie—a decline of 22½ per cent. The 20 year bonds

sold at 88 for specie in January, and for 72½ in December, a decline of 15½ per cent., although none of that description had been negotiated in that period. The 1 year certificates of the Government had fluctuated from time to time, as the creditors who received them from the Government pressed them upon the market for sale. From par in April for specie currency they fell to 96½ for paper at the close of the year. Under the supposition that the certificates had on average 6 months to run, the holder gets in half a year for his outlay of \$96½, \$100 principal and \$3 interest in gold, worth \$4 in paper, or \$104; making \$7.75 equal to 16 per cent. per annum on his investment. With this state of affairs before holders of Government securities, the Secretary announced 1,000 millions more to be borrowed. Yet he complained of "the ignorant fears of foreign investors in national and State bonds and other American securities, and the timid alarms of numerous nervous indivi-

duals in our own country, which prompted large sacrifices upon evidences of public and corporate indebtedness in our markets." The "foreign investors" measure the value of stocks not by paper but by the gold standard, and a fall of 28 per cent. in United States 20 year 6 per cent. stock was not an assuring fact. On page 303 of the "Cyclopædia" of last year is given the amount of specie estimated, from the best official data, to have been in the country at different periods. The whole amount for the Union, North and South, for January, 1862, was \$237,510,148. This includes the specie in circulation, in banks and that used in the arts. The quantity used in the arts has been matter of conjecture, since there are no accurate data on which to estimate. The census of 1860 for the first time gave some particulars in relation to the use of the metals. In the city and county of New York the report was as follows:

MANUFACTURES.	Number of establishments.	Capital invested.	Cost of raw material.	Male hands.	Female hands.	Value of annual product.
Gilt frames, mirrors, &c.	31	\$189,600	\$273,750	368	..	\$543,900
Gold and silver refining and assaying	5	529,900	524,050	57	..	420,500
Gold chains, jewelry, &c.	54	1,118,000	1,181,680	906	65	2,162,000
Gold leaf.	5	16,000	59,970	28	16	35,500
Gold watch cases, &c.	19	96,900	185,650	127	3	287,600
Silver ware.	20	487,000	693,585	367	19	1,334,680
Silver-plated ware.	35	136,700	900,430	323	126	428,500
Total	189	\$3,219,000	\$2,924,446	2,071	228	\$5,271,800

There are various other branches of manufactures, beside those enumerated above, which consume large quantities of both metals.

The following tabular statement is from the preliminary report on the eighth census of the United States, year 1860. It is here shown,

that in twelve States and the District of Columbia, there are about twelve or fourteen millions used in manufactures annually. If to these we add Ohio, Missouri, California, and other States, the amount will swell to nearly twenty millions of dollars:

JEWELRY, SILVER WARE, &c., PRODUCED DURING THE YEAR ENDING JUNE 1, 1860.

STATES.	Value of watches, &c.	Value of gold leaf and foil.	Value of silver ware.	Value of silver-plated and British ware.	Value of jewelry, watchcases, &c.	Total value.
Maine	....	....	....	\$28,000	\$11,240	\$39,240
New Hampshire	....	....	....	7,500	11,200	18,700
Vermont	....	....	\$24,700	....	5,750	30,450
Massachusetts	\$348,900	\$17,700	198,360	841,375	1,744,906	2,643,241
Rhode Island	269,500	9,000	490,000	....	2,383,173	3,000,473
Connecticut	....	80,000	92,600	1,579,760	195,124	1,857,484
New York	420,870	108,373	1,593,795	568,745	2,779,281	5,464,484
Pennsylvania	430,000	264,600	519,650	561,650	2,354,280	4,129,130
New Jersey	4,500	....	7,000	665,500	1,604,344	2,281,344
Delaware	....	....	....	....	1,800	1,800
Maryland	....	....	30,000	....	600	30,600
District of Columbia	....	....	....	....	15,950	15,950
Total	\$1,478,470	\$479,673	\$2,894,105	\$3,742,580	\$10,964,908	\$19,554,636

The amount of raw material here used is not stated; but it may be placed at one half, or in round numbers at 10 millions. A large portion of this, however, is old material worked over. It is, however, estimated that about one half, or \$5,000,000, is new metal, worked into the various objects of the goldsmith's art. In the last ten years of great prosperity the quantity of gold wrought up has much increased at the expense of the metallic currency. The use of plate particularly has become more common. There are many causes of error in an estimate

of the metals. Thus much specie is brought in by immigrants, and not reported at the custom house; but as this is mostly foreign coin, it finds its way to the bankers, who sell it to exporters, when it appears in official returns. Much silver comes in overland from Mexico. A good deal of specie also goes out in the hands of travellers, and is not accounted for. Nevertheless the official returns of imports and exports, with that of the product of mines, afford a good approximation. The quantity of metals at the North was as follows during the year:

Specie in the Northern banks, January, 1862....	\$70,000,000
" " States generally, &c.....	60,000,000
" " circulation.....	35,000,000
<b>Total in Northern States.....</b>	<b>\$165,000,000</b>
Received from California in 1862... \$24,883,846	
Net exported from New York and Boston.....	65,000,000— 40,117,154
<b>In the Northern States, January, 1863.....</b>	<b>\$125,883,856</b>
In banks.....	\$60,000,000
In States, &c.....	60,000,000—\$120,000,000

In the course of the year, as the price of specie advanced in New York city, the current of the metals began to flow to the common centre. The opening of trade to some extent in the border States following the progress of the armies, produced an additional demand for gold for the purchase of northern productions, which would be sold only for gold. The drain thus occasioned was such that the brokers of western cities raised the price there to some extent; but the great demand was in New York,

where not only shipments became active, but much was taken on speculation to avoid the inevitable rise that would result from the use of paper. The current of silver also set toward Canada in a swelling volume. The moment that silver bore a small premium it ceased to circulate, because every small shopkeeper who received it would lay it aside, and convey it to Wall street to realize of the brokers the premium they offered. In like manner throughout the West dealers, brokers, and bankers collected and sent to New York the coin that fell into their hands, and which they purchased at a premium, to sell at an advance in New York. The current flowed thither in a deepening stream as the premium advanced, and the banks showed a continually increasing quantity on hand, notwithstanding the large weekly exports. The following table shows the movement of specie:

SPECIE MOVEMENT FOR 1862 AT NEW YORK.

MONTHS.	From California.	From circulation.	Imports.	Exports.	In banks.	Price, per cent.
January.....	\$2,199,588	\$921,794	\$168,658	\$3,658,974	\$37,479,588	2 @ 5
February.....	3,250,795	3,142,406	62,007	2,776,919	29,526,959	5 @ 44
March.....	1,946,752	3,554,154	89,397	2,471,288	32,941,909	13 @ 24
April.....	1,884,117	3,558,406	26,159	4,087,675	35,397,944	1 @ 24
May.....	1,989,771	5,791,477	110,888	5,164,636	31,397,294	5 @ 24
June.....	1,911,099	6,892,492	61,028	9,867,614	30,583,636	44 @ 24
July.....	1,961,468	6,781,868	919,001	8,067,887	34,022,490	9 @ 20
August.....	2,070,198	1,619,681	92,708	3,718,589	35,640,984	124 @ 164
September.....	2,641,918	3,876,668	121,218	3,035,919	37,592,559	16 @ 194
October.....	2,387,298	3,532,545	256,676	6,707,519	39,348,947	224 @ 39
November.....	2,651,211	805,333	109,708	6,218,251	37,949,086	29 @ 38
December.....	1,483,267	3,976,169	178,216	3,678,119	35,780,807	31 @ 384
<b>Total in 1862.....</b>	<b>\$25,079,787</b>	<b>\$43,907,975</b>	<b>\$1,890,277</b>	<b>\$59,437,021</b>	<b>\$40,971,000</b>	
" " 1861.....	24,485,949	....	27,083,413	4,236,250	29,080,000	

The largest amount of specie received from the interior in any one month was in July, when the rate rose suddenly in New York to 20 per cent. for gold. The supply so drawn to the city caused a decline, and the receipts in August were small, increasing again in September, when gold recovered. When, however, the highest point was reached in October, the receipts fell off, showing as well an exhaustion of the floating specie, as a disposition on the part of individual holders not to sell at any price. With a price of 33 per cent. in November the receipts fell to a nominal amount as compared with July, and the export drain falling upon the banks they lost nearly \$4,000,000. The California supplies are barely more than three fourths those of last year. The metals continued to be the currency in that State, and instead of being quoted at a premium for Government notes, the latter are quoted at a discount for coin. The above table shows that there were collected into the New York banks from circulation 39 millions of specie, mostly sent abroad. In the previous year the reverse was the case: 37 millions were imported and sent into circulation.

This year the fluctuations in the metals induced numbers of small speculators to buy gold when it fell, and on the occasion of a rise, they swarmed the brokers' offices to resell. Gradu-

ally, however, the amount of circulating specie in the country seems to have been absorbed, since the very high rates that ruled in October ceased to bring forward enough to supply the export demand. The supply from California was nearly reduced by the great number of shipments direct to England in consequence of the increasing risks of navigation. Toward the close of December the steamer Ariel, on her passage out to Aspinwall, was captured by the Confederate steamship Alabama. The troops on board were paroled, and the ship ransomed in order that she might proceed with her passengers. In consequence she did not, on her return to New York, venture to bring her freight of gold, amounting to \$533,119, and the United States gunboat Connecticut was sent out to bring it home. Meantime, however, the Ocean Queen arrived at New York, January 3d, with \$1,270,580, including the Ariel's freight. In consequence of this capture the insurance companies raised the rate of insurance from 3 to 5 per cent. Thus giving fresh inducement to turn the golden stream from New York to England direct.

The operations of the New York assay office, under the changed condition of the specie trade, were exceedingly small as compared with the previous year. They were as follows:

NEW YORK ASSAY OFFICE FOR 1862.

Months.	Deposits.						Payments.	
	Gold.			Silver.			In bars.	Coin.
	Foreign.	United States.	Total.	Foreign.	United States.	Total.		
January.....	\$86,000	\$402,000	\$488,000	\$31,400	\$6,609	\$38,009	\$400,000	\$70,000
February.....	16,000	562,000	578,000	18,900	18,200	37,000	568,000	52,000
March.....	85,000	151,000	186,000	28,600	2,400	26,000	188,000	79,000
April.....	42,000	67,500	109,500	12,900	1,600	14,500	59,000	65,000
May.....	82,000	54,000	86,000	15,500	6,500	22,000	51,000	57,000
June.....	24,000	58,000	82,000	19,400	3,600	23,000	56,000	49,000
July.....	82,000	128,000	155,000	28,100	4,900	33,000	106,500	91,500
August.....	54,000	350,000	404,000	16,980	590	17,500	88,000	388,000
September.....	15,000	104,000	129,000	18,880	2,870	17,700	57,000	68,700
October.....	19,000	112,000	131,000	28,910	3,090	32,000	90,600	72,400
November.....	28,000	99,000	127,000	21,000	9,000	30,000	70,000	67,000
December.....	23,000	120,000	149,000	18,750	2,250	21,000	55,700	108,800
Total in 1862 ..	\$856,000	\$2,202,500	\$3,574,500	\$249,170	\$61,539	\$310,709	\$1,729,800	\$1,157,900
" " 1861 ..	89,211,500	24,206,000	63,417,500	1,995,490	818,000	2,704,000	2,868,000	62,879,500
" " 1860 ..	4,785,100	12,275,100	17,010,860	888,200	806,620	689,520	3,881,000	15,822,000
" " 1859 ..	272,000	4,006,800	4,277,600	511,480	118,720	625,200	3,971,000	1,629,100

The deposits of gold declined from nearly 63½ millions to 2½ millions, and the payments in coin became nearly nominal. Of the silver deposits \$22,000 was from the new mines

of Washoe, and \$7,000 from those of Lake Superior. The operations of the United States mint underwent a corresponding reduction; they were as follows:

MONTHS.	Gold.		Silver.		Cents.
	Deposits.		Coinage.		
	Deposits.	Coinage.	Deposits.	Coinage.	
January.....	\$439,188 99	\$418,168	\$86,490 42	\$124,411	\$12,000
February.....	255,976 65	808,818	77,963 02	117,920	10,000
March.....	107,408 01	171,817	33,112 61	50,260	11,000
April.....	158,875 62	162,671	34,486 46	28,206	10,000
May.....	567,727 21	174,164	23,648 41	26,694	10,000
June.....	174,160 13	588,757	23,612 60	42,888	15,000
July.....	286,065 07	157,695	32,170 10	18,488	30,600
August.....	529,768 58	440,322	17,698 76	22,481	24,000
September.....	804,074 61	410,996	25,866 94	18,045	28,000
October.....	386,217 79	886,372	39,462 61	35,518	35,200
November.....	270,065 44	263,629	38,392 08	41,153	40,200
December.....	345,907 59	212,680	21,309 97	21,134	54,350
Total in 1862 ..	\$3,719,385 69	\$3,695,088	\$454,218 93	\$547,083	\$280,850
" " 1861 ..	62,077,041 00	67,631,356	2,952,341 00	3,107,740	102,000
" " 1860 ..	15,063,365 00	11,851,711	549,218 00	687,119	214,660
" " 1859 ..	1,555,252 00	1,455,678	910,560 00	1,048,646	345,000

The manufacture of money has thus declined to a very small amount at the national mint, although the national printing presses have been very prolific substitutes.

The use of paper money during the year in its effect upon business has not been adverse to the interests of holders of goods and property. It has indeed checked the movements of importers, since it has caused the cost of importation to rise faster than the market prices of the commodities. This has diminished importations, thereby giving additional effect to the paper in its influence upon the value of goods held. These have generally risen in price under the joint influence of small importations, lessened production, higher duties, and paper money. The rise thus brought about has been a welcome profit to many holders of goods. The following table gives the range of prices of some leading articles at the beginning and close of the year (see Table A).

This list suffices to show the general rise which has affected all branches, some more and some less according to the peculiar circumstances of each article. Some commodities, of which the value depends mostly upon the export demand, and which in the absence of that demand sells no higher than at the same time

TABLE A.

ARTICLES.	December, 1861.		December, 1862.		Rise, p. ct.
	December, 1861.	December, 1861.	December, 1862.	December, 1862.	
Sterling exchange..	\$1.10 @	\$1.10½	\$1.45 @	\$1.47	36
Gold.....	1.00 @	—	1.32 @	1.38	32½
Copper, Am. Lake..	0.28 @	0.25	0.31 @	0.33	20
Iron, Am. pig.....	0.21 @	0.22	0.21 @	0.21½	48
Lead, Am. Galena..	6.00 @	6.75	8.00 @	8.50	35
Ashea, pot.....	8.00 @	6.25	8.50 @	8.75	25
Coffee, Brazil.....	0.17½ @	0.19½	0.27½ @	0.31	60
Cotton, mid. fair...	0.86 @	0.86½	0.67 @	0.69	90
Dry cod.....	8.25 @	4.00	4.50 @	4.62	25
Flour, western.....	5.60 @	5.80	6.80 @	6.35	38
Gunny cloth.....	0.18 @	0.18½	0.14½ @	0.15	10
Hay.....	0.80 @	0.90	0.90 @	1.00	12
Hemp, dressed.....	215.00 @	225.00	250.00 @	280.00	20
Hides, Buenos Ayres	0.23 @	0.22½	0.25½ @	0.25½	20
Hops.....	0.14 @	0.20	0.15 @	0.25	25
Leather, B'n's Ayres	0.19 @	0.21½	0.37 @	0.80	40
Lima, Rockland.....	0.60 @	0.62	0.85 @	0.87	40
Molasses, Cuba.....	0.20 @	0.28	0.24 @	0.28	24
Turpentine spirits..	1.40 @	1.42	2.50 @	2.65	90
Oil, whale.....	0.48 @	0.52	0.88 @	0.85	90
Oil, coal.....	0.25 @	0.35	0.45 @	0.50	50
Pork, mess.....	12.00 @	12.50	14.87 @	14.50	16
Lard.....	0.08 @	0.08½	0.09½ @	0.10	20
Whiskey.....	0.25 @	0.25½	0.39 @	0.39½	60
Sugar, Cuba.....	0.06½ @	0.05½	0.05 @	0.10	20
Tallow, city.....	0.08½ @	0.09	0.10½ @	0.10½	9
Tin, Banca.....	0.80 @	0.81	0.42 @	0.43	40
Tobacco.....	0.07½ @	0.20	0.14 @	0.23	40
Whalebone.....	0.75 @	0.80	1.50 @	1.65	100
Wool, fleece.....	0.52 @	0.55	0.58 @	0.66	10
Wool, pulled.....	0.44 @	0.45	0.56 @	0.59	25

last year, have actually fallen in value to the extent of the rise in exchange. Other articles

have fallen to a lesser extent, as in the case of hay, which, nominally 10 per cent. higher, is really for shipping purposes 25 per cent. lower than last year. Nevertheless, relatively to the other articles of the home market, there has been a general and large rise in prices, which has operated beneficially for all who held stocks of goods, and this state of affairs has given activity at par prices to goods which had been deemed "dead stock," but which became salable. As a consequence, a certain degree of prosperity has manifested itself in business circles, and the number of failures has been far less than last year.

The actual number of failures in the Northern States, as compared with last year, with the amount of liabilities, is as follows, per the report of the mercantile agencies:

	1861.		1862.	
	No.	Liabilities.	No.	Liabilities.
<b>New York:</b>				
N. Y. City and B'klyn	980	\$60,067,114	162	\$7,491,000
Albany	47	2,348,500	20	300,500
Buffalo	26	300,000	5	55,000
Oswego	13	180,000	4	45,000
Rochester	87	319,000	12	150,000
Syracuse	36	549,000	10	90,000
Troy	33	330,000	8	70,000
Utica	35	359,000	12	50,500
Rest of State	660	7,700,100	230	2,365,000
<b>Massachusetts:</b>				
Boston	430	18,317,161	130	3,013,000
Rest of State	363	6,794,000	111	1,042,300
<b>Pennsylvania:</b>				
Philadelphia	339	\$1,394,368	60	1,310,000
Pittsburg	49	747,397	15	115,000
Rest of State	327	2,943,500	115	1,250,000
<b>Illinois:</b>				
Chicago	91	5,117,170	17	370,000
Rest of State	350	4,911,300	115	980,000
<b>Ohio:</b>				
Cincinnati	163	6,992,071	10	80,000
Cleveland	22	604,000	5	60,000
Rest of State	397	5,379,500	105	950,000
<b>Rhode Island:</b>				
Providence	54	1,093,000	5	30,000
Rest of State	14	163,000	10	50,000
<b>Michigan:</b>				
Detroit	50	1,119,200	10	110,000
Rest of State	169	1,320,200	52	345,000
<b>Iowa:</b>				
Dubuque	10	370,000	8	70,000
Rest of State	93	1,295,000	55	325,000
<b>Indiana:</b>				
Indianapolis	253	2,562,000	95	500,500
<b>Wisconsin:</b>				
Milwaukee	17	587,304	5	125,000
Rest of State	113	2,137,500	45	450,500
<b>New Jersey:</b>				
New Jersey	146	2,284,300	65	535,000
<b>Connecticut:</b>				
Connecticut	131	2,594,000	37	350,000
<b>Maine:</b>				
Maine	76	710,000	43	470,000
<b>New Hampshire:</b>				
New Hampshire	90	840,000	30	90,000
<b>Vermont:</b>				
Vermont	116	1,433,000	23	230,500
<b>Minnesota, Kansas, and Territories:</b>				
Minnesota, Kansas, and Territories	53	4,912,500	22	120,000
<b>Total Northern States</b>	<b>5,935</b>	<b>\$178,683,170</b>	<b>1,652</b>	<b>\$23,042,300</b>
<b>Canada West:</b>				
Toronto	23	\$323,000	22	\$405,000
Rest of Canada West	144	2,362,200	105	1,250,000
<b>Canada East:</b>				
Montreal	53	1,351,530	30	642,333
Rest of Canada East	48	544,000	42	540,000
<b>Rest of British North American Provinces:</b>				
Rest of British North American Provinces	47	1,391,000	29	455,200
<b>Total Brit. Provinces.</b>	<b>310</b>	<b>\$6,471,769</b>	<b>268</b>	<b>\$3,292,533</b>
<b>Total Northern States and Brit. Provinces.</b>	<b>6,245</b>	<b>\$185,154,939</b>	<b>1,920</b>	<b>\$26,334,833</b>

The failure by months, as exhibited in the following figures, show that the larger portion

occurred during the first quarter of the year, or before the advance in the value of goods to which we have been alluding:

January	374	July	151
February	353	August	118
March	263	September	75
April	179	October	57
May	108	November	84
June	84	December	89

The failures for previous years are given in the "Cyclopædia" for 1861. The amount this year has been reduced to a small item comparatively. The beneficial effect of paper money has thus been produced, but the danger commences. The goods if realized on cannot be replaced at their prices, but buyers must meet the rising market, which momentarily becomes more hazardous, because subject to the collapse of the paper money. Stocks have followed the same course of advance under similar influence. The monthly prices for the year 1862, will be seen in Table B, on the following page.

The average advance in the stocks was 40 per cent; that is, the sum of the quotations for December is 40 per cent. more than the sum of the quotations for January, showing that the rise in prices of stocks has about equalled that of gold and exchange. The average advance of the commodities in the above table of prices is also 38 per cent., thus showing a singular uniformity in the rise of prices.

The list embraces Government, State, and railroad stocks. These latter represent the proprietorship, and the theory of the paper money influence is, that the debts of the companies may be easily discharged in paper money, thus leaving the stock more valuable than before.

The advance which pervades all descriptions of business compels the railroads to demand higher freights and fares. This swells the sums of their revenues, and although their expenses are also more, yet the result is a higher profit. Thus a railroad may have earned in 1861 \$7,000,000, paid \$1,000,000 interest, and \$4,000,000 expenses, and it would have \$2,000,000 surplus; on the supposition that its expenses doubled in paper, and that it doubled its charges, it would pay \$8,000,000 running expense, \$1,000,000 interest, making \$9,000,000, which from \$14,000,000 revenue would give \$5,000,000 surplus. Under this operation the first effects would be to improve second class bonds, which would now get interest in full. Ultimately, as the process progresses, the bonds would be paid off in this species of paper, leaving the roads clear to the stockholders. The question of the constitutionality of the legal tender notes must be settled however. Already suits have come before the courts, where payment of mortgages has been tendered in legal tender and refused, on the ground mainly that the State courts cannot recognize anything but specie as a legal tender: a law of Congress cannot override this proviso of the Constitution.



TABLE B.  
PRICES OF STOCKS IN NEW YORK FOR THE YEAR 1863.

STOCKS.	Jan'y.	Feb'y.	March.	April.	May.	June.	July.	August.	Sept.	Oct.	Nov.	Dec.
United States 6's, 1861, coupons.....	89	92½	98	98	105½	105½	96½	101½	102½	104	104	102½
United States 6's, 1874, coupons.....	79½	85	87½	89½	92½	96	85½	90	91	98	99	92
United States 7½ Treasury notes.....	98	99½	99½	109½	106½	104½	109½	104½	104½	105½	108½	101½
United States certificates.....	—	—	96½	99	100	100	98½	99½	99½	99½	97½	96½
United States demand notes.....	100	100½	100½	100	100½	104½	106	106	118	125½	129	126½
American gold.....	108½	102½	101½	102½	108½	109½	115½	115½	121½	129½	129	129½
Virginia 6's.....	51½	59½	57½	57	56½	57	58½	56	59	65	60	61½
Missouri 6's.....	49½	59½	51½	51	51½	50½	46	47½	49	59½	51½	54
Tennessee 6's.....	44½	59½	56½	57½	59	57½	50½	51	51	54½	54	54
California 7's.....	89	86½	88	89	96½	97½	96	99½	108½	114½	119	119
Delaware and Hudson.....	92½	92	89	92	99½	92	97	100½	110	111½	114½	118½
Pennsylvania Coal.....	87	85½	81	80½	90	96	96½	99½	106	109	112	118½
Cumberland Coal.....	5	7	8	8½	8½	8½	8	8	12½	12½	12½	14½
New York Central Railroad.....	89½	83½	82½	85½	88½	92	89½	94½	102½	108½	101½	105½
Erle Railroad.....	84½	85	86½	87½	87½	86	82½	83½	49	64½	60½	65
Erle Railroad preferred.....	56½	58½	60½	61½	68½	68½	62½	68½	82½	91½	91½	96½
Hudson River.....	85½	87½	85½	86½	44	46	44½	58	61	79	72½	78½
Harlem.....	19½	19	19½	18	14	16½	14½	16½	21	91	91	25½
Harlem preferred.....	81	90½	80½	80½	85½	41	85½	40½	47½	49½	50½	57
Reading.....	42½	49	41½	45	49	56½	56	61½	69½	78½	75	77½
Panama.....	118½	120½	120	126½	189	188	184	140	145½	154	158	170
Michigan Central.....	52	58½	55½	56½	62½	59½	69½	81	90½	88	88	91
Michigan Southern.....	29	24	29½	23½	25½	26½	25	31½	37	45½	37½	44½
Michigan Southern guaranteed.....	42½	47	46	47½	57½	59½	55½	68½	79	84	82½	85½
Illinois Central.....	61	68	61½	61½	62½	60½	57½	62½	76½	81½	77½	81½
Cleveland and Pittsburg.....	16½	18½	17½	18½	29	29	21½	25½	35	38½	40	55½
Galena and Chicago.....	67½	68½	67½	68	69½	71	67½	72½	80½	85½	80	83
Cleveland and Toledo.....	41½	45½	45½	48½	44	48	47½	58½	68½	70½	66½	76½
Chicago and Rock Island.....	55	56½	55	56½	62½	67½	68	67½	77½	86½	77½	83
Burlington and Quincy.....	62½	64	61½	66½	72½	77½	78½	87½	98	96	88	90½
Pacific Mail.....	99	98	91½	110½	115½	115½	111	111½	120	122½	119	126½

For finances of the Confederate States see CONFEDERATE STATES.

FLORIDA, which forms the South East Peninsula of the United States, contained in 1860 a population of 140,425, of whom 77,748 were white, 932 free colored, and 61,745 slaves. The ratio of increase for the previous ten years had been white 64.70, slave 57.07; total 60.59. The white male population of the State by the census of 1860 was 41,128; female 36,619. The decrease of the slave population during the ten previous years by manumission was 17; by escapes 11. The mortality in the State for the year ending May 31st, 1860, was 1,769, of whom 979 were males, 790 females, and 329 under the age of one year. The most fatal diseases are consumption, diarrhœa, dropsy, fever, remittent and typhoid, and pneumonia. Deaf and dumb 18, of whom 9 are slaves. The product of iron foundries for the year ending June 30th, 1860, was valued at \$63,000; value of sawed and planed lumber \$1,475,240; flour and meal \$355,066; cotton goods manufactured \$40,000; value of shad fishing \$68,952; value of real estate and personal property \$73,101,500. Lands improved 676,464 acres, ditto unimproved 2,273,008; horses 16,562, mules, &c., 2,294, cattle, exclusive of working oxen and cows, 284,736, sheep 29,958, swine 274,814; wheat 2,808 bushels, rye 21,314 bush., corn 2,824,538, oats 46,779 bush.; rice 223,209 pounds; tobacco 758,015 pounds; cotton 63,322 bales of 400 pounds each; wool 58,594 pounds; peas and beans 364,738; sweet potatoes 1,218,493 bush.; sugar 1,761 hhds., molasses 485,890 gallons. Value of home manufactures \$62,243; miles of railroads 401. The area of the State is 59,268 square miles, or 37,981,520 acres. It is divided into 33 counties. Key West is the most im-

portant commercial and military point in the State, Tallahassee is the seat of the State Government, Jacksonville has been a thriving commercial town on the St. John's river, from whence vast quantities of lumber were exported. The number of cotton plantations in 1850 was 990, and of sugar plantations 958. The Governor of the State is John Milton, whose term expires in November, 1863. The State election is on the first Monday in October, and the Legislature meets on the first Monday in November.

The State of Florida quietly reposed under the flag of the Confederate States until the military and naval expeditions were sent from Port Royal by Com. Dupont to capture her towns on the eastern coast. (See ARMY OPERATIONS.)—These expeditions met with very little resistance. Fernandina and New Fernandina were taken on the 3d of March, Jacksonville on the 12th, next St. Augustine and Musquito Inlet. The occupation of these points and the blockade outside gave to the Federal Government the control of the whole coast of east Florida. Situated as the State was, at a distance from the seat of the Confederate Government, which required all its available force to defend the northern border of the seceded States, the Confederate Government determined to relinquish the possession of the eastern portion of the State when the attack was made on Fernandina. An order was accordingly issued by the Secretary of War at Richmond, directing the Confederate forces to withdraw from the State. All the cannon, arms, ammunition, and stores were removed at the same time. These troops were sent into Tennessee to aid in resisting the Federal forces there. The effect of these measures was to discourage the efforts of the people for the Confederate cause and to prevent sol-

diers from enlisting in the army. If they were to be abandoned by the Government, their services were required to defend their homes instead of going to fight abroad, was the answer to the call of President Davis for 2,500 additional troops. Early in April, the Confederate defences at the entrance of Pensacola bay were evacuated and Forts McRae and Barrancas dismantled. A few soldiers yet remained in Pensacola, having made every preparation for a hasty retreat. At the same time all the towns on the west coast of the State were either evacuated or nearly so. Tampa Bay only was held with an appearance of military possession, but the garrison was prepared to evacuate on the approach of a hostile force.

The occupation of Jacksonville by the Federal forces was followed by active movements in favor of the Union, which are described in connection with the *Army Operations*. The position is the Key of east Florida, and it was held by about fifteen hundred Federal troops. With one or two gunboats, they were sufficient to hold the place against any force which might have been brought against them. By an order of Gen. Hunter, commanding the department of the South, with headquarters at Port Royal, the town was evacuated. Many of the citizens of Jacksonville who had fled, were induced to return while it was occupied by this force, and avow their loyalty, by a proclamation issued by Gen. Sherman, the predecessor of Gen. Hunter. This promised to all good citizens protection to life and goods. By the evacuation of the town, they were deprived of this protection, and having once expressed Union sentiments, they became marked men. Fifty-four of them, embracing men, women and children, were brought to New York in a steamer, when the troops left, and others came in a sailing vessel.

Although such a large proportion of the citizens of the State had volunteered in the army, and although the crops during the year were successful, yet the Legislature, to guard against a scarcity, passed an act forbidding the exportation from the State of any beef cattle, dried or pickled beef, hogs, pork, bacon, corn, corn meal, salt, or provisions of any kind. The same act forbid any person to buy these articles for the purpose of speculation, and directed that they should be sold at a price not to exceed 88 per cent. over cost and charges.

A scheme for the armed colonization of Florida was brought to the notice of the Federal Government by Eli Thayer of Massachusetts, during the year. It consisted of a proposition for an expedition of ten thousand colonists enlisted for six months, and to be supplied with arms, subsistence, and transportation by the Government, and a commander whose business it should be to occupy and hold the public lands of the State and the lands of disloyal citizens, which were to be seized for the non payment of taxes under a law of Congress passed at the session then closed. It received some consideration by the Government, but was not adopted.

FRANCE. The ten years, which had elapsed in November, 1862, since Louis Napoleon, by French suffrage, became Napoleon III, emperor of France, were witnesses of great changes in the political, social, intellectual, and moral condition of France. When by the *coup d'état* of December, 1851, the present emperor seized the reins of government, the whole country was in the condition of the crater of an active volcano, seething and boiling for another eruption: the peasantry impoverished, and in dread of losing their little all; the great artisan class, ill supplied with work, and clamoring for bread, and the "right to labor;" the *bourgeoisie* or mercantile and shopkeeping class, sick and disgusted with revolution, and willing to accept any government which would insure peace and quiet, and the opportunity of gain; the army discontented, and sympathizing too much with the masses to be a fit dependence for the government against the people. Paris, the heart of France, was, in the older portions of it, a city of narrow streets, courts and lanes, overshadowed by the lofty stone palaces of the middle ages, and there were hundreds of localities, where a resolute mob, erecting from the paving stones and other materials a barricade, could set at defiance a large army.

The people, as a body, were sick of republicanism; they preferred to be governed, to be governed well, but rigorously, and to be governed *much*, their idea of a paternal and beneficent government being that it must show its hand in all the affairs of social life.

No man understood the French character better, or was more competent to manage it in a way to promote his own purposes, than Louis Napoleon, and when, as "the elect of seven millions," he ascended the imperial throne, it was with a fully matured purpose and a well digested plan of maintaining a dynasty of Bonapartes. The measures by which he has accomplished this purpose thus far, are the conciliation of all classes of the French people by gratifying their tastes, while making them the agents to carry out his plans. He determined that there should be no more battles of the barricades; and, under the plea of improving and beautifying Paris, he has run straight, broad and elegant boulevards through every portion of the ancient city, and annihilated the old courts, lanes, and narrow streets, till now his cannon, trained upon any thoroughfare, could sweep away, with a stroke, every vestige of insurrection. He had determined to attach the army to the throne and to his dynasty, and he has modified the conscription laws so as to make service in the army profitable and desirable; he has cultivated the *esprit du corps*, and the love of glory, always a Frenchman's weakness, by noticing and rewarding deeds of bravery, by promotions from the ranks, by making his little son an officer of the army, and by the thousand measures which his astute and observing mind had taught him were most likely to win a French army's affection. The

artisans were conciliated by the abundance of employment furnished by the great changes making in the cities, by the increased rate of wages, and by the regulation, by imperial authority, of the price of provisions. The *bourgeoisie* found, in his vigorous administration, the strong government they had desired, and order and quiet being established, they had full opportunity to pursue their gainful traffic, and their speculative disposition was stimulated to the utmost by the emperor. The peasant class, assured of the possession of their little homesteads, and having the opportunity to invest their small hoardings in government securities, which they could not previously do, became the strong friends of the government. At times, indeed, floods, short crops, and financial panics brought distress, and occasioned some grumbings of discontent with the government, but the "empire was peace" to its inhabitants, and furnished them protection, while it ruled them with a strong arm; and none knew better than the emperor that the surest panacea for discontent at home was a foreign war. Hence, the conflict with Russia was rather sought than shunned; hence, Austria was menaced and driven into war; hence, Italian unity was delayed, that Europe might see that Napoleon III was the arbiter of its destinies; hence, too, the Syrian occupation, the war with China, the conquests in Anam, the attack on Mexico, the proffered mediation between the Northern and Southern States of the United States.

Other enterprises, also, home and foreign, tending to occupy and amuse the minds of the people, were undertaken. The building of railroads was stimulated; the construction of substantial highways aided; emigration to, and development in, Algeria encouraged; the great Suez canal project taken up and vigorously prosecuted, and considerable tracts of territory, on both the eastern and western coasts of Africa, secured.

These measures of policy were attended with some inconveniences which were rather formidable. The debt of France, which at the beginning was large for the resources of the country, has been constantly increasing at the rate of about 75 millions of dollars a year, and now amounts to \$1,902,923,400, and the current annual expenditure, now \$413,853,291, has been annually from 60 to 80 millions in excess of the ordinary revenue, while the extraordinary credits opened, at the pleasure of the emperor, for such purposes as he deemed desirable, have produced the utmost confusion in the finances of the state. The material prosperity of the citizen was the great aim and end of the government; the press was not only not free, but was under the control of a most rigid censorship; intellectual progress, except in the few directions which could not be considered as trenching upon the imperial prerogative, was trammelled and almost prohibited. Glory and territorial conquests abroad, wealth and the power that money brings at home, were the aims and

ends to which the hearts of the French people were directed.

In the Annual Cyclopædia for 1861, the position of the empire with reference to the important questions of external and internal policy, which pressed upon it during that year, is briefly stated, and a similar review with reference to 1862 will be in place here.

The relations of France to Great Britain have been, on the whole, tolerably cordial. Its industrial progress was well represented in the great International Exhibition at London, and though some complaints were made at the withdrawal of that power from the Mexican expedition, and at its refusal when urgently solicited to concur in proffering a mediation between the United States and the Southern Confederacy, and at its demonstrations in regard to Syria, Greece, and the Suez canal, and a semi-official encouragement given to Spain to urge the surrender to her of Gibraltar, yet there were no serious disturbances of the comity observed for many years between the two powers.

Elsewhere on the Continent the policy of France has generally been peaceful. The Swiss difficulties have been settled; the personal interview between the emperor and William I, king of Prussia, led to a more cordial feeling between the two Governments; indications were not wanting of a Franco-Russian alliance, which, however, the sympathy of France for Poland in insurrection at the beginning of the present year may not impossibly prevent; the Austrian emperor has found nothing to complain of in the policy of France, and the manœuvres for taking possession of any portion of the Turkish empire have been, from the necessity of the case, postponed to a more convenient season. The imperial wishes have been thwarted in Greece, but the emperor has succeeded in defeating the desires of the British Cabinet also; in Italy, the expectant policy has, in the main, been pursued, and in the Ratazzi Cabinet (*see ITALY*) Napoleon III found willing tools for his purpose; but the defeat of Garibaldi, and the suppression of his movements upon Rome, which the emperor compelled Victor Emmanuel II to undertake, opened the eyes of the Italian Parliament and people to the selfishness of the French policy, and lost the emperor his former prestige in that country. In Egypt, his relations with the late viceroy, Said Pasha, were very cordial; the pasha visited France during the summer of 1862, furnished some black troops for the Mexican expedition, and gave his assistance liberally to the Suez canal. (*See AFRICA.*) Under the head of Africa are also detailed his operations elsewhere in Africa, Madagascar, Senegal, &c. In Asia, the year witnessed a number of severe battles between the allied French and English troops and the Taepings in China (*see TAEPING REBELLION*), and in the spring by a short but vigorous campaign the French became masters of three provinces in Cochin China, besides securing the opening of several of the Anamese ports to

their trade. This conquest, though confirmed by a treaty, seems to be of somewhat uncertain permanence, as just at the close of the year, the Anamese had risen in insurrection, and made very determined and resolute attacks upon Saigon and Mytho, and though repulsed with considerable loss, there was room for apprehension that they would overwhelm the little garrisons in those towns by sheer weight of numbers. (*See* COCHIN-CHINA.)

In Mexico (*see* MEXICO) the British and Spanish allies having both withdrawn from the expedition, the French have been left to conduct the war alone, and have met with numerous and somewhat serious reverses; reinforcements have been repeatedly sent out, but the success of the French arms, and the "establishment of the power of the Latin race on this continent, as a counterpoise to the Anglo-Saxon," which the emperor, in his letter to Gen. Forey, so strongly indicated as his purpose, seems yet hardly realized. The gallant resistance of Mexico to this invasion has excited little sympathy among the European powers, with the exception of Italy, which sees in it the counterpart of its own struggles for freedom and independence.

In his relations to the United States the French emperor has maintained a strict and careful neutrality, neither attempting to run the blockade, nor suffering privateers to be fitted out in his ports to prey upon our commerce. He has sought to unite the leading powers of Europe in a proposal for mediation, (*see* DIPLOMATIC CORRESPONDENCE), and failing in that, proposed late in the autumn an armistice and convention in some foreign country between the two belligerents. During the summer of 1862, his minister at Washington, M. Mercier, visited Richmond, and held an interview with the Confederate authorities.

At the commencement of the year there was an intense excitement throughout France in regard to the Society of St. Vincent de Paul, which had its central council at Paris, and its affiliated associations, under the control of the central council, throughout the empire. As this Society was, to some extent, made one of the organs of the ultramontane party among the clergy, to attack the Government for its supposed opposition to the preservation of the temporal power of the Papacy, and as neither the Society nor its branches had taken out authorizations, as all benevolent societies in France are required to do, from the prefect of the place where they are established, and these authorizations give the prefecture the power of regulating, and if necessary, of suppressing them, the Government directed that they should take out in each city and town an authorization, or be suppressed. In most instances the authorization was taken out, and on the 5th of April the central council of the Society was dissolved, 766 out of the 854 local societies having signified their preference for independent existence. A part of the masonic

lodges of the empire were closed about the same time, and some of the nunneries, which had been too active in their proselytism of Jewish children, were deprived of their authorizations.

The sanguine hopes entertained at the close of 1861, of a reform in the finances under the vigorous and skilful administration of M. Fould, were not destined to be wholly realized. This was not attributable to want of financial ability on the part of the minister, but to the extraordinary exigencies of the country; the Chinese war, the conquests in Cochinchina, and above all the war in Mexico, required large and to some extent unforeseen expenditures, and although on the 9th of October, the finance minister expressed the belief that the expenditure of the year would be about 157 millions of francs less than that of the preceding year, and that he should be able to commence the year 1863 with a reserve of 80 millions of francs, instead of a deficit as had been usual, the subsequent large expenditure occasioned by the disasters in Mexico seems to have thwarted his plans, and the surplus was only 4,800,997 francs, while the budget for 1863, 2,069,507,518 francs, was 100 millions of francs (\$20,000,000) in advance of that for 1862, and with very little hope of any considerable surplus, even from the extraordinary taxes and imposts to be levied to raise it, the ordinary revenues indicating a deficiency of at least 885,000,000 francs. That the current expenditure of a nation of 37,000,000 inhabitants, in a time of no great or general wars, should reach the sum of \$418,853,291 seems singular, and indicates gross extravagance of expenditure somewhere. The legislative body (*corps législatif*) answering to our House of Representatives, endeavored in a protracted discussion on the budget to effect a reduction of 8,000,000 francs (\$1,600,000), but the finance minister replied that the utmost allowable decrease would be 771,841 francs (\$154,268), and with this slight reduction they were forced to be content.

The larger liberty promised to the *corps législatif* and to the press had excited many hopes and anticipations, most of which were doomed to disappointment. The legislative body was indeed allowed somewhat more of freedom in the discussion of topics of finance and state policy, and their speeches were permitted to be reported stenographically; but when the democratic members made vigorous and eloquent arguments in favor of the withdrawal of the French troops from Rome, or the adoption of a real instead of a pretended liberality and authority in legislation, their arguments were suppressed and the papers were restrained by *communiqués* from publishing them. Still something was accomplished, the emperor had set his heart upon granting from the public treasury an annuity of 50,000 francs upon the general, Cousin-Montauban, Count Palikao, and a bill to that effect was introduced into the legislative body, but the

reputation of the count was bad, and the bill was rejected, and although the emperor somewhat angrily demanded its passage, it was a second time and almost unanimously rejected, and the baffled monarch was compelled to withdraw it. The prosecution of the war with Mexico has also excited a considerable opposition, which at the session of the present year is likely to be materially increased.

The press at first supposed that the notices and compulsory cessation of publication which had been the fate of the greater part of the newspapers of Paris and the other cities of France, at one time or another within the past ten years, were to be henceforth abandoned, and were a little riotous, perhaps, in their newfound liberty; but the delusion was a brief one, and they soon found that though the name of the thing was changed, a "communiqué" was just as effective a check upon the freedom of the press as a "notice." The censorship both of books and newspapers, has, in fact, been maintained with even greater rigidity, though under somewhat different forms, during the past year than in any of the ten which have preceded it.

The heavy duties imposed by the United States Congress on silks and other fabrics imported from Europe in 1861, and the general stagnation of trade induced by the American war, greatly depressed the manufacturing interest in France, and the silk manufacturers of Lyons were under the necessity, for a time, of stopping their looms; great suffering ensued among the operatives of that city and its vicinity, which was aggravated by the fact that there was early in 1862 a dearth in cotton, which rendered the production of cotton goods difficult and unprofitable. Lyons is not however the principal seat of the cotton manufacture; Rouen and the department of *Seine Inférieure*, and the departments adjacent have almost the monopoly of the production of French prints, while other descriptions of cotton goods are manufactured in Normandy. Of the 89 departments into which France is divided, 14 are, to a considerable extent, engaged in the production of goods of which cotton is partially or entirely the material. The scarcity and high price of cotton in the autumn of 1862, caused the closing of the greater part of the manufactories, and in the departments of Rouen and *Seine Inférieure* alone it was estimated that at the close of the year 30,000 workmen were out of employment and starving, and half as many more in Normandy. At the commencement of 1863 active measures were taken to raise funds for their relief, and large contributions were made by individuals, cities, and the Government.

STATISTICS.—In France a census is taken every five years, but it extends only to the population, not to the agricultural or industrial productions, mines, or railroads. The last census was taken in 1861. It gave as the population of the 86 original departments of France 36,-

735,871, and adding the population of the newly annexed departments of Savoy, High Savoy and Nice (645,108), the whole population of the France of to-day was 37,400,974. The increase in the population of the old departments in 5 years, was 716,507; in ten years, 972,812; and in 15 years, 1,355,385, or 3.79 per cent. in 15 years. Of this increase 1.99 per cent. was since 1856. The increase of the French population is slower than that of any other nation of Europe, although the losses by emigration are not large. The two great wars of Italy and the Crimea, the short crops, and the revolutions through which it has passed, may all have had their influence in producing this result; but the general laxity of morals, and the abandonment of so many infants, legitimate or illegitimate, to the foundling hospitals, have unquestionably been the principal cause. The population since 1789 has increased but about 38 per cent., being at that time 27,957,165. The sexes are more nearly equal in numbers than anywhere else in Europe except in Italy, the excess of females over males being only  $\frac{13}{100}$  of one per cent. Of the males 27.25 per cent. are unmarried (including children), 20.18 per cent. married, and 2.49 per cent. widowed; of the females, 25.81 per cent. are unmarried (including children), 19.01 per cent. are married, and 4.81 per cent. are widows.

In 26 departments, there had been an actual loss of population amounting in all to 101,678; in 60 departments there had been a gain, though in some it was very slight.

There has been no census of agricultural products since 1852; but that year, being a good average year for crops, will indicate pretty nearly the average amount at present; while in grains, it will be in excess of the last two years, which have been years of short crops. The crop of wheat in that year was 278,321,420 bushels; of barley, 48,943,245 bushels; of maize and millet, 23,813,088 bushels; the entire crop of cereals was 640,849,488 bushels, and it was valued at \$522,833,840.40 for the grain, and \$119,145,203 for the straw. The crop of potatoes was 165,859,400 bushels; of peas and beans, 17,428,571 bushels. The value of garden products was \$7,708,100, and of orchard products, \$6,900,492. The entire value of agricultural productions was \$1,127,498,580. The number of horned cattle the same year was 10,098,737; of sheep, 33,281,592; of swine, 5,246,403; of goats, 1,337,940; of horses, mares and colts, 2,866,054; mules, 315,831. Total value of live stock, \$556,192,282, the total annual gross product of farm animals (including 1,956,241 hives of bees) was \$548,800,096. The production of brandy was \$12,878,078; of beer, \$12,679,842; of cider, \$9,439,140; of Colza oil, \$23,285,058; of olive oil, \$5,940,225; of nut oil, \$2,857,679; of silk, \$13,198,094. The entire amount of industrial products, derived immediately from agriculture was \$30,072,713. An industrial census was

taken in 1861, but its results are not yet published.

The imports of France for the year ending Dec. 31, 1861, were \$1,105,900,000, of which \$617,420,000 was under the head of general, and \$488,480,000 of special commerce; the exports were \$917,500,000, of which \$582,240,000 belonged to general and \$335,260,000 to special commerce. Of the imports, grain and flour were the largest items, amounting together to \$78,000,000, and cotton next, amounting to \$54,120,000; raw silk amounted to \$38,220,000, and wool unmanufactured to \$34,280,000. The other most important items were coal, sugar, coffee, oleaginous grains, coffee, indigo, live stock, wines and spirituous liquors, olive oil and zinc. Of the exports, silk fabrics took the lead, being valued at \$66,580,000; and next in order were wines, \$39,180,000; woollen goods, \$37,600,000; dressed and prepared skins and leather, \$18,800,000; cotton goods, \$11,840,000; spirits \$10,020,000; grain and flour, \$6,820,000; metals, manufactured, \$7,660,000; refined sugar, \$8,400,000; raw silk, \$6,120,000; and considerable amounts of live stock, glass and porcelain, linen goods, and machinery. The number of vessels entering French ports in 1861 was 80,021, measuring 4,934,000 tons; of which 11,653 were under the French, and 18,368 under a foreign flag. The number of vessels which cleared the same year was 17,246, measuring 2,684,000 tons, of which 6,868, were French and 10,378 foreign vessels.

The number of miles of railroad completed and in operation in France on the 1st of July, 1862, was 6,276, miles, of which  $\frac{1}{2}$  was single track, and  $\frac{1}{2}$  double track. The gross receipts of these roads in 1861 were \$92,080,211. There were in 1862, 97 canals, having a total length of 2,829 miles, and there were also 5,290 miles of river navigation, a part of it made navigable by artificial means.

The French army in 1862 on the peace footing amounted to 404,192 men of all arms, and could be raised by calling out the entire force on the war footing to 757,725. Of this force about 250,000 were infantry, 60,000 cavalry, 39,000 artillery, and 7,400 engineers. In addition to this there are about 117,000 armed police, and 500,000 of the National Guard, answering very nearly to our militia. The navy of France in 1862 consisted of 94 iron clads, carrying 1,142 guns and having a total horsepower of 21,136 (of these 56 were gunboats of 1, 2, or 4 guns, 19 more floating batteries of 16 or 18 guns, for harbor defences, and 14 were 40 gun frigates); and one ship, ten frigates, and 13 floating batteries, of the whole number, were in process of construction. Besides the iron clads, there were 178 screw steamers, and 86 sidewheel steamers not iron clad, having together 6,196 guns and 81,300 horse power, and 111 sailing vessels, mostly ships of the line and frigates, carrying 2,380 guns. Total, 478 vessels, with 9,718 guns, and 102,486 horse power, of which 24 (all iron clads) are building.

The postal service in France increases rapidly. The charge for single-letter postage throughout France is 20 centimes, or 3 $\frac{1}{2}$  cents. 274,000,000 letters and 189,000 newspapers passed through the post offices in 1861. The amount of money orders transmitted was about \$105,000,000. The gross receipts for the letter postage were \$11,120,000.

The extent of the telegraph lines in 1862 was 14,799 miles, the number of stations (aside from railroad stations) 454, and the number of despatches 1,388,200.

FREDERICK, the capital of Frederick county, Maryland, and the capital of the State in 1861-'62, is situated on Carroll creek, two miles from its mouth, in Monocacy river. It is connected with the Baltimore and Ohio railroad by a branch road, three miles in length. The city is well built, the streets are wide and regular, and lined with houses of brick or stone. It contains a court house, jail, several churches, banks, scientific and literary institutes, corn and flour, lumber and paper mills, and is the second city in the State in commercial importance. The population in 1860 was 8,148, and that of the county 46,591. The county has an area of 770 square miles, and is bounded on the southwest by the Potomac river, which separates it from Virginia, intersected by the Monocacy river, and also drained by Catoctin, Pipe, Lingunore, and Bennett's creeks. The South Mountain, a continuation of the Blue Ridge of Virginia, forms its western boundary, and the surface is generally undulating. The soil, formed of decomposed limestone and slate, is highly productive. The city of Frederick was occupied by the Confederate army, under Gen. Lee, on the 7th of September; for particulars of which see ARMY OPERATIONS.

FREDERICKSBURG, a city of Spottsylvania county, Virginia, is pleasantly situated on the right bank of the Rappahannock river, at the head of tide water. It is 65 miles north from Richmond, and 110 miles from Chesapeake bay. The population in 1860 was 5,022. It contained a court house, jail, several churches, two banks, and two seminaries, an orphan asylum, a grist mill, and some large tanneries. Above the city are falls in the river which furnish valuable motive power. The railroad from Aquia creek, on the Potomac, to Richmond passes through the city, and was the principal route between Washington and Richmond. A canal also extends 40 miles above the city, affording an outlet to the productions of the rich farming country above. Nearly opposite the city, on the left bank of the river, is the little town of Falmouth, which was made the headquarters of Gen. Burnside while in command of the Federal army. Fredericksburg was evacuated by the Confederate troops, as their army retired from northeastern Virginia, and soon after occupied by the Federal troops without opposition. It was subsequently evacuated by the Federal troops in August, 1862, as Gen. Lee, in command of the Confed-

erate forces, advanced toward Maryland. Subsequently, as the Federal army appeared before the city, in November, a surrender was demanded. The commander of the Confederate force in the rear of the city caused the answer to be given, that his command would neither occupy the city or suffer the Federal army to do it. The heights in the rear of the city finally became the scene of a bloody battle between the Confederate forces under Gen. Lee and the Federal forces under Gen. Burnside. (See ARMY OPERATIONS.)

**FREEDOM OF THE PRESS.** There has been no interference with the usual publications of the press during 1862, beyond the orders to abstain from publishing information of intended military movements. On the 25th of February, the Secretary of War issued the following order to the Chief of Police at Washington:

WAR DEPARTMENT, WASHINGTON, Feb. 25.

To the Chief of Police:

All newspaper editors and publishers have been forbidden to publish any intelligence received by telegraph or otherwise respecting military operations by the United States forces. Please see this night that this order is observed. If violated by any paper issued to-morrow, seize the whole edition, and give notice to this department that arrest may be ordered.

EDWIN M. STANTON, Secretary of War.

On the next day the following more general order was issued:

WAR DEPARTMENT, WASHINGTON, Feb. 25.

It is ordered that from and after Feb. 26, the President, by virtue of an act of Congress, takes military possession of all telegraph lines in the United States.

2d. All telegraphic communications in regard to military operations not expressly authorized by the War Department, the general commanding, or the generals commanding armies in the field, in the several departments, are absolutely forbidden.

3d. All newspapers publishing military news, however obtained, and not authorized by official authority, will be excluded thereafter from receiving information by telegraph, or from transmitting their paper by railroad.

4th. E. S. Sanford is made military supervisor of telegraphic messages throughout the United States, and Anson Stager military superintendent of all telegraphic lines and offices in the United States.

5th. This is not intended to interfere in any way with ordinary business of companies or private business.

By order of the President.

(Signed)

EDWIN M. STANTON,  
Secretary of War.

On the 17th of March an order was issued from the War Department, directing the seizure of the Washington "Sunday Chronicle," and the parties concerned in its publication, in consequence of having published on the previous day information of military movements in disregard of general order No. 67.

The order of arrest was placed in the hands of the military governor of the District, and the editor of the paper brought before him. The editor stated that the news was handed in at a late hour, and the paper went to press without his personal supervision. He expressed his regret at the violation of the order, and promised to carefully guard against a recurrence

of similar publications. Whereupon, at the request of the military governor, he being satisfied that the offence would not be repeated, the execution of the order was suspended.

The following order, issued in August, 1861, was continued in force:

WAR DEPARTMENT, ADJ'T GENERAL'S OFFICE,  
Washington, August 26, 1861.

*General Order No. 67.* By the 57th article of the act of Congress, entitled an "An act for establishing rules and regulations for the government of the armies of the United States," approved April 10, 1806, holding correspondence with or giving intelligence to the enemy, either directly or indirectly, is made punishable by death, or such other punishment as shall be ordered by the sentence of a court martial.

The public safety requires a strict enforcement of this article. It is therefore ordered that all correspondence and communications verbally, or by writing, printing or telegraphing, respecting the operations of the army, or military movements on land or water, or respecting the troops, camps, arsenals, intrenchments, or military affairs within the several military districts, by which intelligence shall be directly or indirectly given to the enemy, without the authority or sanction of the general in command, be and the same are absolutely prohibited, and from and after the date of this order, persons violating the same will be proceeded against, under the 57th article of war.

(Signed)

L. THOMAS, Adj.-General.

The subject of restrictions on the press was brought before Congress, and the following resolution was referred to the Judiciary Committee of the House:

*Resolved,* That the Judiciary Committee be requested to inquire if a telegraphic censorship of the press has been established in this city, and, if so, by whose authority, and by whom it is now controlled; to report if such censorship has not been used to restrain wholesome political criticism and discussion, while its professed and laudable object has been to withhold from the enemy information in reference to the movements of the army.

The report of the committee was made on the 20th of March, in which they state the following conclusions:

*First.* A telegraphic censorship of the press has been established in this city.

*Second.* The censorship existing at the time the investigation was directed by the House, was originally established upon the basis of the agreement between the representatives of the press and Gen. McClellan, but was enlarged in its scope by the Secretary of State.

*Third.* At the time the inquiry was directed by the House, and for some months prior to that time, and until the 25th of February last, the censorship was controlled by the Secretary of State.

*Fourth.* The original design was to prevent the publication of military information which might be of advantage to the rebel authorities.

*Fifth.* Despatches, almost numberless, of a political, personal and general character, have been suppressed by the censor, and correspondents have been deterred from preparing others because they knew they could not send them to their papers by telegraph.

The telegraph has become a most important auxiliary to the press of the country, and should be left as free from Government interference as may be consistent with the necessities of the Government in time of war. These necessities cannot extend beyond what may be legitimately connected with the military or naval affairs of the nation, and to these should the Government interference with the transmission of intelligence be confined, for it is this character of information alone which can be of importance to the enemy,

and which may be properly withheld from the press and the public, in order that it may not reach the enemy. The committee, therefore, recommend the adoption of the following resolution by the House:

*Resolved*, That the Government should not interfere with the free transmission of intelligence by telegraph, when the same will not aid the enemy in his military or naval operations, or give him information concerning such operations on the part of the Government, except when it may become necessary for the Government, under the authority of Congress, to assume exclusive control of the telegraph for its own legitimate purposes, or to assert the right of priority in the transmission of its own despatches.

FRELINGHUYSEN, THEODORE, LL.D., an American statesman, and scholar, born at Millston, Somerset co., N. J., March 28, 1787, died at New Brunswick, April 12, 1862. He graduated at Princeton College in 1804, studied law, and was admitted to the bar in 1808, where he soon gained a high reputation as a lawyer. In the war of 1812, he took part as a captain of a company of volunteers. In 1817, he was chosen attorney-general of the State by a legislature opposed to him in politics, and in 1826 was transferred to the United States Senate. During his period of service there, whatever acts came before Congress, having for their object the amelioration of the condition of the poor and oppressed, or of elevating their moral or religious character, received his hearty support. He was one of the earliest officers of the American Colonization Society, advocated bills for the improvement of the condition of the Indian tribes, the suppression of Sabbath mails, and

supported Mr. Clay upon the question of the tariff, and the compromise act of 1832. In 1835, he left the Senate, and was succeeded by a democratic Senator. In 1838, he was chosen Chancellor of the University of New York. In 1844, he was the nominee of the whig party for vice-president when Henry Clay was the candidate for the presidency. In 1850, he resigned the chancellorship of the University, and became president of Rutgers's College, New Brunswick, N. J., which position he occupied until his death. He filled many places of honor and of trust in civil life, and in the walks of learning, and adorned them in no ordinary degree with the graces of the man and the Christian.

FRONT ROYAL, the capital of Warren county, Virginia, is one mile east of the Shenandoah river, and 140 miles north of northwest of Richmond. The town is situated in a valley between the river and the Blue Ridge Mountains—the gap in which receives its name from the town. The railroad from Alexandria to Strasburg passes through this gap and the village. A plank road of 20 miles in length connects the latter with Winchester. Numerous flouring mills use the water power of the river. It was here that the advance of Gen. Jackson's force met a most spirited resistance from the 1st Maryland volunteers, under Col. Kenly, on the 28d of May, which defeated his design to cut off the retreat of Gen. Banks. It was subsequently, during the year, the scene of important military movements.

## G

GEOGRAPHICAL AND ARCHÆOLOGICAL EXPLORATIONS. An epoch of civil war is not usually a time for extensive geographical explorations or discoveries; yet the past year has not been wholly fruitless in discovery in the United States or the North American Continent. Early in the year Congress published the elaborate report of Captains Humphreys and Abbott, who had been appointed in 1857 to survey the Mississippi river and its tributaries, and whose labors were brought to a close in 1861. This report is full of interest and importance, not only to hydrographical science, but to the military and naval operations of which that great water-course is now the seat. The great western tributaries of the Father of Waters, the Missouri, Red, and Arkansas rivers, were explored to their sources, their breadth, depth, and the character of the soils of the regions through which they pass accurately noted, and their usual periods of flood and ebb investigated. The military operations, which have been conducted in so many of the States of the Union, have been fruitful in reconnaissances and surveys, many of which will contribute to render the topography

of those States much better understood in the future than it has been in the past.

The explorations for new mines of the precious metals have been unusually successful during the year. In California several new silver mines, and one extensive deposit of cinabar (the ore of quicksilver) have been discovered, and copper deposits of great extent brought to light; in Nevada, the discovery of new silver lodes has been of almost weekly occurrence. In Colorado, the veins of gold-bearing quartz, and of pyrites rich in gold, have been found in almost all parts of the mountain ranges of that territory. The mines in Arizona on the Colorado river, long known to yield gold and silver in considerable quantities, have been opened and found richer than was previously supposed. The Salmon river, and John Day and Powder river gold mines in Oregon and Washington Territory (now included in the new Territory of Idaho), though discovered the year before, received their principal development in 1862; and a new mining region of extraordinary promise was discovered in the summer of 1862, on Grasshopper river, an affluent of the Yellow Stone, in lat. 43°, long. 109°



80' W. from Greenwich, near the boundaries of Dakota, Nebraska, and Idaho, on the eastern slope of the Wind River Mountains. The great yield of gold in the placers of this region has already attracted a very considerable population thither, and a new territory will probably be organized there by the next Congress.

Considerable investigations have also been made concerning the flora and fauna of Lower California, by Mr. John Xantus, at Cape St. Lucas, under the direction of the Smithsonian Institution; and of the region lying south of Hudson's Bay, by some of the officers of the Hudson's Bay Company, especially by Mr. Bernard R. Ross, chief factor of the Mackenzie River district at Fort Simpson, and Mr. Lawrence Clark, jr., of Fort Rae, on Slave Lake. These gentlemen have not only contributed large collections of specimens of the flora and fauna of these regions, but have added materially to our knowledge of the character, habits, and customs of the Esquimaux.

Mr. Robert Kennicott has been for some years past employed, at the joint expense of the Hudson's Bay Company and the Smithsonian Institution, in exploring the northwestern portion of this continent. In September, 1860, he reached Fort Yukon, a port on the Yukon river in Russian America, lat. 65°, long. 146° W. from Greenwich, where he remained till the summer of 1861, and after spending the season in exploring that part of Russian America, hitherto almost wholly unknown, returned to Fort Simpson in the early autumn, and expected, in the spring of 1862, to penetrate to Fort Anderson, at the mouth of the Anderson river (a stream between the Mackenzie and Coppermine rivers), and collect the fauna of that portion of the Arctic Ocean in the summer of 1862, and return during the present year to the United States. The region thus explored has, much of it, not hitherto been penetrated by any competent observer, and Mr. Kennicott's report will undoubtedly be replete with interest.

An English expedition sent out in 1861, and composed of Messrs. Hind, Montgomery, and several other gentlemen, have explored the interior of Labrador, and ascended the Moise river for several hundred miles; but they find little of interest to report; the country is hopelessly sterile. The efforts of our countryman, Tal. P. Shaffner, Esq., to procure the laying of a telegraphic line between Great Britain and America by way of the Faroe Islands, Iceland, Greenland, and Labrador, have been powerfully seconded in England by Captain McClintock, and the route proposed has been examined, but as yet without practical result. There seems to be reason to fear that the icebergs in their resistless movements would destroy some of the cables of this line, though it would have much less length of submerged cable than the route proposed and once constructed through the efforts of Mr. Cyrus W. Field. This last is to be again attempted, the obstacles being so far removed that the organization of a company

and the preparation of a cable is rendered certain, though it will probably not be laid before the summer of 1864.

The latest, though probably not the last, of the arctic explorations was completed in the autumn of 1862. Mr. C. F. Hall, formerly of Cincinnati, whose departure from New London, Conn., in the whale ship *George Henry*, on the 29th of May, 1860, we chronicled in the "Annual Cyclopædia" of 1861, returned to that port on the 18th of September, 1862. He reached Frobisher's Strait, as it has been called for about 800 years, in August, 1860, and soon after his arrival a fearful gale arose, which destroyed the shallop in which he had intended penetrating to the open sea around the north pole, and came near wrecking the *George Henry*. By the advice of the Esquimaux, he postponed efforts to proceed northward to the next summer, and explored, as far as he was able, the shores of the waters in which the vessel was compelled to winter. He discovered that the so-called Frobisher's Strait was a deep bay, terminating in lat. 63° 48', and long. 70° W., the entire shore of which he traversed. In the spring of 1861, he procured a whale boat from the *George Henry*, and with a crew of six natives, started on his northern journey to the Countess of Warwick's Sound, and after much difficulty succeeded in discovering the place where Frobisher, in 1574 or 1575, had attempted to plant a colony. Numerous relics of this ill-fated colony were found, consisting of pieces of coal, wood, iron, broken bottles, and trenches dug for holding a supply of water. Among the natives he found a woman called *Oo-ki-zox-inoo*, or the "White Bear," more than 100 years' old, who had heard from her parents about the capture and final death of the white men, and who recounted the story with great fidelity. At the head of Frobisher's Bay, he discovered a large mountain in which was an extensive deposit of fossils. Near Queen Elizabeth's Land, he found an immense glacier more than 3,000 feet high, one hundred miles in length, and fifty in width, which he named, in honor of Mr. Henry Grinnell, "The Grinnell Glacier." He also believes that he has determined the fate of two of the boats' crews of Sir John Franklin. During the winter of 1861-'2, the ship's company were subsisted mostly by the generous hospitality of the Esquimaux. Mr. Hall speaks in high terms of the bravery, honesty, truthfulness, and hospitality of the Esquimaux. He brought home with him a family of this people, whose intelligence and ability as interpreters he had fully proved.

During the year, the Northwest Boundary Survey, conducted under the direction of Mr. Archibald Campbell, completed its labors, and returned to Washington. The commission met with a great loss in the death, in Feb., 1862, of its surgeon and naturalist, Dr. C. B. Kennerly. The report of the survey has not as yet been published.

A French savant, M. Brasseur de Bourbourg,

who has passed many years in the exploration of Mexico, and the investigation of the habits, manners, and religion of the Indian tribes, found there by the Spanish invaders, published near the close of 1861 a remarkable work, entitled *Popol Vuh*, which he declares to contain the sacred book of the Quichés translated from the hieroglyphic language, and also the legends of the settlement of Mexico by that tribe and their heroic annals, and a few months later followed it with a grammar and dictionary of the Quiché language. During the past year M. Ferdinand Denis has furnished to the *Revue Orientale et Américaine*, a Mexican paleograph bearing upon the same subject. Dr. Poyet, well known by his Turkish explorations, has been for the past two years exploring South-eastern Mexico, and has sent home some interesting maps and descriptions of his discoveries in the State of Vera Cruz.

M. Garcia y Cubas has published within the past year a large atlas of the Mexican Republic, and M. Francis Lavallée has issued a work on the natural and political history, productions, &c., of that country.

In *Central America* the surveys and explorations connected with the proposed opening of new routes to the Pacific have brought to light many interesting facts. The United States Government have purchased a considerable tract of land at Chiriqui in Costa Rica, and proposed to send out a colony of free men of color there, but the protest of the Costa Rican Government led to a delay and finally to the abandonment of the project. In the little town of Vertud in the department of Gracias, Honduras, a grotto has recently been discovered, in the upper part of which is a fountain called *fuentes de sangre* (fountain of blood), the liquid thrown up by which resembles in color, smell, and taste the blood of mammals. From the fountain it flows through the lower part of the grotto, depositing in its progress some apparent coagula, and discharges itself into the waters of a neighboring creek, which it reddens. Vultures, buzzards, and dogs seek for it greedily, especially when it is coagulated, and fatten from partaking of it. Considerable quantities of it have been taken away in bottles for analysis, but it decomposes very rapidly, and almost always bursts the bottles which contain it. Prof. Silliman has made an analysis of it and finds it very rich in organic matters, and regards its sensible properties as probably due to the presence in it of large quantities of colored infusoria.

Honduras has established Amapula on the island of Tigré as its principal port on the Pacific. A German geographer, M. Max of Sonnenstern, has issued the past year a very complete map of Central America, the result of recent explorations, and Dr. Frantz has published a narrative of his visits to the volcanoes of Costa Rica.

In *South America*, there have been as usual many political changes and revolutions, and though perhaps less actual geographical explo-

rations than usual, the results of previous explorations have been published to a greater extent than at any former period.

In New Grenada, or as that republic now styles itself, the Confederation of the United States of Colombia, a French expedition under the direction of M. Boudiol is engaged in exploring the isthmus of Darien, in order to determine definitively the practicability of an interoceanic canal. Señor Samper, a distinguished scholar and a native of New Grenada, has published in the Spanish language during the past year a complete history, geographical, ethnological, and political of the Confederation, and has also communicated to the scientific journals of France several interesting papers concerning the physical features and races of New Grenada. Maurice Wagner, a German geographer, has issued a very complete map of the isthmus of Panama, and has accompanied it by a full letter-press description of the physical geography of the isthmus, and Mr. William Bollart has published a work on the antiquities and ethnology of New Grenada. The Confederation has, by a decree, taken possession of the two islands St. Andrew and Providence, situated opposite the coast of Mosquitia, and which are very rich in guano.

Venezuela has been in a condition of civil war during the whole of the past year, and has had little opportunity for geographical explorations, but a very elaborate paper on its geology, prepared by M. Wall, has appeared in the *Zeitschrift der Erdkunde*; and Don Ramon Paez, son of the present President of that republic, has published at the commencement of the present year (1863), an interesting work entitled, "Wild Scenes in South America, or Life in the Llanos of Venezuela," which is a valuable contribution to the natural history and geography of the country. M. Cortambert, a French geographer, has compiled an elaborate work, from the notes of Dr. Plassard, on the productions and people of the Orinoco basin, and among others upon the geophagi or earth-eaters of that country.

In Ecuador, an American engineer, named James Wilson, has made a journey of exploration from the shores of the province of Esmeraldas to Quito, with a view to ascertain the practicability of constructing a railroad to connect Esmeraldas and Quito.

It has been known for many years past that the *Jivaros*, a tribe of Indians occupying the eastern part of the Republic of Ecuador, worshipped the heads of the prisoners whom they had taken in battle and decapitated; and it was said by travellers that they had some process by which they reduced these heads to a very small size. Many attempts have been made to obtain some of these idol heads for the ethnological collections of Europe or America; but such was the reverence in which they were held by the Jivaros, that until 1861 it was impossible to obtain a single specimen. In June, 1861, Prof. Cassola brought one to Lon-

don, which had been stolen from a temple on the river Pastaza. A second was obtained by a baptized Indian from a Jivaro who had much ill luck, by the representation that the idol head was tired of its imprisonment, and unless permitted to travel would continue to persecute him. Since that time ten of these heads have been sent to the United States, and two of them are in the possession of Dr. Merritt of New York. M. Bollärt, who has spent much time in Ecuador, thus describes the consecration of these heads as idols: The bones of the head are removed through the base, a heated stone introduced, and this process repeated until complete desiccation takes place, and the head (on which the long hair is retained) is reduced to about one fourth its original size; the appearance of the features being maintained, and the desiccation having been so uniform that there is no appearance of wrinkling in the skin. This accomplished, a feast takes place, in which the victor roundly abuses the head, which is made to reply in terms of defiance, an Indian priest acting as spokesman for it. Upon this the victor raises his lance, strikes and wounds the face of his enemy, and then sews up the mouth, condemning it to silence except as an oracle; and it is only consulted when the inquirer is under the influence of a narcotic (generally the coca). A double string is attached to the top of the head that it may be worn round the neck, and from the closed lips twenty or thirty cords a foot or more in length depend, the use of which is uncertain. If repeatedly disappointed in the results of their supplications to the idol head, the Jivaro women cut off its hair and throw it into the woods.

The governors of *French and Dutch Guiana* have sent out a joint scientific commission to explore the upper regions drained by the Maroni river, which separates these two colonies, and their report will probably be published during the present year.

*Brazil* has within the last two or three years been very fully explored; and during the past year many of the results of the labors of the geographers and naturalists who have penetrated into the interior of the empire have been given to the public. A journal of physical science, the *Revista Trimensal*, is published at Rio Janeiro, and each number contains important geographical papers. A German savant has published, during the past year, the results of his explorations under the title *Brasilianische Zustände und Aussichten*; M. Biard, a French painter and naturalist, has described the scenery of the country in his *Deux Ans au Bresil*; M. Schultz, a German geographer, has described the *Sao Francisco* basin in the *Zeitschrift der Erdkunde*, and Dr. H. Kiepert has illustrated it with an excellent map. Doctor Moore, a citizen of Brazil, and a geographer of high reputation, has, in connection with the eminent French geographer Malte Brun, published a geography of the Brazilian empire in the Portuguese language, and has described in the bulletin of the

French Geographical Society his explorations in the Paraguay basin. The region lying in the vicinity of the yet undetermined boundary between Brazil and French Guiana has been very fully described by the Chevalier J. O. de Silva, in a work in two volumes entitled *Oyapoc*. Of the interesting narrative of explorations of the brothers Grandidier in South America in 1857-'9, published the past year by M. Ernest Grandidier, the larger part is devoted to Brazil. Lieutenant Ashe, an English officer, has given in the *Nautical Magazine* an account of his journey across the Brazilian Andes.

Dr. Burmeister published early the last year the narrative of his travels in the Argentine Confederation from 1857 to 1860, and M. Martin de Moussy, who is still occupied in the exploration of these States, has already given to the public two volumes of his journeyings. Dr. Demersay, a Paraguayan scholar, has in progress of publication an elaborate physical, economical, and political history of Paraguay. Gen. Reyes has published within the past year a treatise on the geography and history of Uruguay. The Argentine Confederation, aside from its chronic condition of war with the State of Buenos Ayres, which during the past year has been terminated once more by a peace, has suffered from severe earthquakes, though none have been so terribly destructive as that which in 1861 made the flourishing city of Mendoza a heap of ruins. At Catamarca, in the northern portion of the Argentine Confederacy, a rich and extensive lode of silver has been discovered.

In *Chili*, M. Pissia, the eminent Chilean geologist and astronomer, is still at the head of the geodesic and geologic survey of the country which is in progress. M. Baldomero Menendez has published, the past year, a statistical and geographical manual of the Chilean Republic, and M. Philippi has continued his observations on the Chilean Andes, describing in a recent paper the formation of a new volcano near Chillan in 1861. In the southern portion of Chili, occupied by the independent and brave Araucanos, an Indian tribe famous in history, a Frenchman named Orelie Antoine de Tonnens, who had resided for many years among the Araucanos, and who, as an educated man and a graduate of the Polytechnic School of Paris, had acquired a powerful influence among them, persuaded them on the 17th of November, 1860, to recognize him as their king, under the title of Orelie Antoine I, and to make the throne hereditary in his family. The Chilean Government were greatly displeased at this movement, especially as they had been for some time purposing to press the Araucanos farther south, and had even taken possession of some territory S. of the Biobio river, which had hitherto been their boundary. The new king determined to regain the lost territory and advanced with a considerable force toward the Biobio, but, while yet some miles distant from it and within his own acknowledged territory, was surprised on the 4th of January, 1862, with

his staff, by a large Chilian force, who had been guided to his encampment by a treacherous Indian, and, having been seized and disarmed by the Ohiliana, was committed to the prison at Nacimiento, where at the latest intelligence he was still incarcerated.

M. Guinnard, a French traveller, who passed three years in captivity among the *Poyuches*, a Patagonian tribe, has given, in the *Tour du Monde*, an interesting description of the geography, productions, ethnology, &c., of Patagonia, and a vivid narrative of his perils and sufferings in making his escape to one of the Chilian ports. The French have taken possession of the island of Tova on the E. coast of Patagonia, which has extensive deposits of guano.

On the western side of South America, M. Paul de Marcoy, a French astronomer, has published an interesting volume of travels in the Peruvian Andes, and the indefatigable explorer Von Tschudi is still pursuing his investigations in the same region.

In the *West Indies*, Messrs. F. Lavallée and F. Pastrana have published in the bulletin of the French Geographical Society, a historical and geographical sketch of the island of Porto Rico, with a fine map. M. Wall has made a geological exploration of Trinity Island, and Señor J. de Sivers has given to the world a treatise on the geography of Cuba. A new map of Hayti, much more complete than any which have preceded it, was published at Paris by the Haytien Government near the close of 1861. The Dominican Government was formally annexed to Spain in 1861.

Crossing the Atlantic, we find a few items of geographical interest in *Europe*. The trigonometrical survey of Great Britain and Ireland, begun in 1783, has during the past year been completed, and its results have been published in 7 quarto volumes. This survey has been connected by several triangulations with those of France and Belgium, which in their turn are connected with those of Holland, Denmark, Germany, Prussia, and Russia, and will furnish the means of measuring an arc of parallel of 75°. A cadastral survey of Ireland, Scotland, and England is also in progress, and a map of Ireland in 205 sheets, on the scale of one inch to a mile has been published, and those of Scotland and Ireland, on the same scale, are in the course of publication.

Sir Henry James has commenced the publication of a series of maps of the whole world on the scale of two inches to the mile, the intention being to have the sheets uniform in scale, so that any number of them could be united to give the map of a country or a continent without the need of adaptation, which has hitherto been a great difficulty with geographers. Six sheets have been issued, and an effort is making to enlist the geographers of other countries in the enterprise, so as to make the maps the best possible representations of all portions of the earth's surface.

The topographical survey of Spain has been prosecuted with great vigor during the past year, and the central provinces have been accurately mapped, and the entire triangulation of the first order completed.

M. Adrien Block has published a volume of the statistics of the different states of Europe, with an Atlas, a very complete and valuable work. M. Rudolph has completed a very elaborate gazetteer, geographical, topographical, and statistical, of all the towns in *Germany*. Two valuable geographical works on *Italy* have also been published during the year: *Le Royaume d'Italie, étudié sur les lieux mêmes*, by P. de Tchihatchev, and *L'Italia meridionale, o l'antico Ream delle Due Sicilie*, by J. de Luca. *Turkey* in Europe has been very thoroughly explored, especially its northern and eastern provinces, and *Servia* and *Montenegro* have been fully described by Boué, by M. Henri Thiers, and by Messrs. Lestak and Scherb, and *Eastern Bulgaria* by Dr. Allard.

In *Asia*, *Syria*, *Palestine*, *Damascus*, and the *Hauran* have been very thoroughly explored during the past three or four years. The works of Graham, Porter, and others had already made us familiar with the two latter, and no oriental tour was complete without a visit to the former; but during the French occupation of *Syria* several commissions were sent out by the French Government to explore the ancient ruins and relics of Phœnician, Philistine, Edomite, Macedonian, and Roman rule in these regions, and their investigations have brought to light much that is interesting. The report of the Phœnician commission was drawn up by M. Ernest Renan, one of the most eminent of French oriental scholars, and brought to light many new facts in regard to the archæology and ancient geography of Sidon, Tyre, and other cities of ancient Phœnicia. M. Poulain de Bossay, who has also explored the ancient site of Tyre within the last two years, has published an essay on the topography of Tyre, in which he controverts some of M. Renan's positions.

M. G. de Perrot, who was intrusted with the direction of the commission for exploring the archæology of *Asia Minor*, discovered in the ancient *Galatia* many remarkable antiquities; among others, at *Ancyra*, the remarkable epigraphic monument known as the "Will of Augustus;" but though it has been asserted and generally admitted that the Galatians were a Celtic race and the original stock from which the Galli or Gauls of France sprung, the explorers could find no trace of Celtic or Druidic monuments in that mountainous region. Several of the French officers of the army of occupation explored very thoroughly the region of the *Libanus*, or *Lebanon* range of mountains; and MM. Emmerich de Rey and Auceptaine penetrated into the *Hauran*, the ancient seat of the great races of *Canaan*, and have published interesting monographs in reference to that hitherto little known region. M. Pierrotti, who has devoted many years to the investiga-

tion, has published recently a very elaborate plan of ancient Jerusalem, in which he has fixed the location of every point mentioned by sacred or profane writers.

Dr. Blau gives, in the *Zeitschrift der Erdkunde*, a narrative of a journey across the Pontic Alps from Erzeroum to Mourad-tchah, a region hitherto seldom traversed by Europeans; and the same journal contains the account of the remarkable explorations of MM. Wetstein and R. Doergens in the interior of Syria. Remarkable physical changes have taken place in the Asiatic Turkish empire during the year past. Mecca has been nearly destroyed by inundations, and the Euphrates has changed its course: quitting its bed near Hilleh, it has taken a more westerly course, and now loses itself in the marshes which extend toward the Persian Gulf.

In Northern and Central Asia the Russians have been the most active and enterprising of explorers, and their savans have led the way for the progress of the Russian flag over vast regions, which for centuries had been the pasture grounds of nomadic tribes, or the homes of fierce and intractable Turkish, Tartar, and Tougousian tribes.

In the Aderbeijan region in Persia, M. Khanikoff, a Russian geographer, has made, in 1861 and 1862, extensive explorations. The Aderbeijan is a lofty plateau in the N. W. of Persia, lying between the Caspian Sea and Mesopotamia. It is shut in on all sides by mountains; on the east, the Talish range separates it from the basin of the Caspian; on the west, the chain of Kandilar forms a barrier between it and the plain of Mesopotamia; on the north, and through the central portion of it, spurs from the Kandilar chain stretch toward the Caspian; and at the south, the Buzgush mountains join Mount Sehend, 11,392 feet high, to the Kandilar range. The plateau at its lowest point, the shores of the salt lake Urmia or Ooroomiah, is 4,062 feet above the sea level, and rises in the lofty peak of Ararat to about 17,500 feet. Mount Savalan, another of its summits, is 15,444 feet high. This region is of special interest to us as having been for many years the seat of an important mission, that to the Nestorians, who, to the number of about 150,000, are settled in villages around the lake Ooroomiah. Professor Ronze, who accompanied a former expedition of M. Khanikoff to Khorassan, has published since his return the flora of Khorassan. The Count Constantin de Sabir has published, within the past year, a very good *résumé* of the recent discoveries in the basin of the Amoor, especially those of M. Maack, a Russian explorer, and has described the physiognomy and habits of the numerous tribes inhabiting the region, the Manegres, Ghiliaks, &c. The same eminent geographer has also sketched the recent explorations of Russia in Central Asia, principally in the country of the Seven Rivers and the Transsilian region. He has found there the ancient Soungaria or Dzoungaria, which, in the middle of the last century, submitted to

China, and ceased to maintain a distinct political existence; it is now divided into two parts, Chinese Soungaria, and Russian Soungaria, or the province of Semi-palatinsk, comprising the districts of Ala-tau, Kopal, and Ayagouz. Among the recent Russian explorers who have visited this region are M. de Semenov, who has crossed the chains of the Ala-tau or Alatau, and the Thian-Shan mountains, and passed through the valleys lying between these ranges, and who has prepared a valuable map of the orographic and hydrographic features of this region; the Sultan Valikhanoff, a Kirghiz prince, a descendant of Genghis Khan, who has explored the slopes of the Thian-Shan, and who first ascertained the circumstance of the death of Adolphe Schlagentweit. Captain Goloboff, whose return we noticed in the "Annual Cyclopædia" of last year, and M. Veniukoff, have explored and mapped the famous lake Issi-Kol or Warm Lake, which bears also the name of Touz-Kol or Salt Lake, and its shores, and have also added materially to our knowledge of the hydrographic systems of this portion of Central Asia. M. Zakharoff, the Russian consul at Kouldja, has also published a map of this region compiled from Chinese data.

M. Kullwein, a Russian savant, who accompanied Gen. Ignatieff in his last mission to Khiva and Bokhara, has recently published a narrative of his voyage, and has given some important information concerning the Amoo-Daria and Khiva rivers.

M. Gustave Radde has explored the region north of Mongolia, the country of the Khalkhas, and ascended the mountain Monkoo-Sardik, toward the northern shore of the lake Kosso-Kol or Kosso-Gol; and since his return has published an interesting map of this region lying between the lake Kosso-Kol and the island of Saghalien.

M. de Romanoff has published an account of the recent Russian explorations on the coasts of Japan and Mantchooria, and has described and laid down upon a map the course of the Lower Amoor, and the new Russo-Chinese frontier, established by the treaty of November 14, 1860. M. Schwarz, the astronomer of the scientific expedition sent out by the Russian Geographical Society, has published a seven-sheet map of Eastern Siberia.

During the past year, M. Schmidt, assisted by MM. Brylkin and Glenn, has been engaged in surveying and exploring the island of Saghalien; and Captain Gamoff has been making astronomical observations between the sea of Japan and the river Ossoori.

One of the results of the Anglo-French expedition to China, and the treaty of Tien-tsin, has been a very great number of exploring expeditions into the interior of China, hitherto so resolutely closed against European intrusion. Among those who have made public the results of their tours of exploration are the Count d'Escayrac, M. E. Desbuissons, and M. Chasirons, among the French writers; and Captain

Blakiston and Commander Brine among the English officers. These journeys of exploration were continued by English officers and civilians, and probably by the French also, throughout the whole of 1861 and 1862, and many of the narratives of the explorers are yet to be published. Captain Blakiston's "Five Months on the Yang-tze" is an exceedingly valuable contribution to geographical science. In company with three friends, Lieut.-Col. H. A. Sarel, Dr. Alfred Barton, and Rev. S. Schereschewsky, an American missionary, he ascended the Yang-tze river to a point 1,800 miles from its mouth, and over one thousand miles higher than any European traveller had previously penetrated, reaching the confines of Tibet. The course and depth of the river, the character of the inhabitants along its banks, the productions, scenery, and temperature, were carefully noted, and the adventures of the expedition, which was one of uncommon peril, are most charmingly described. Commander Brine's narrative is also one of deep interest, though of somewhat graver character. He has given the most clear and complete account of the origin, history, and character of the Tae-ping rebellion, and of the region in which it maintains its authority, which we have seen; he distinguishes between it and the other insurrections, three or four in number, now desolating other portions of that wretched empire, and throws a flood of light on the Chinese character and customs. During the year 1861-'2, six other companies of English explorers traversed China in different directions: Mr. Morrison and Superintendent Harcourt, in January, 1861, set out from Tien-tsin and travelled over land to Che-foo in the N. of China, going in all 700 miles through regions hitherto unexplored, and for nearly three hundred miles of their course passed along the banks of the Grand Canal.

In July, 1861, two English gentlemen, starting from Tien-tsin, penetrated to Mantchoo Tartary by an overland route, and visited Moukden, the capital of that country. They found that the Chinese, though nominally the conquered race, were really the conquerors, having most of the business of the country in their hands, and having imposed upon the Mantchoos, not only their habits and customs, but their language.

In November, 1861, Messrs. Richards and Slosson, also starting from Tien-tsin, undertook an expedition through Pe-chee-le and Shan-le, the two northern provinces of China, and made a tour of 1,560 miles, crossing the Great Wall, which they represent as greatly out of repair, four times.

In the centre of China, four gentlemen, Messrs. Dickson, Sherburn, Beach, and Bonney, passed, in April, 1862, from Canton to Hankow, a distance of 756 miles, and in their route explored the great Tung-ting lake and the course of the Seang river.

During the spring, Mr. Baker ascended the

Tsien-tang river, in Che-kiang, and visited the celebrated green-tea districts of Nganhwuy.

In the south of China, Rev. Dr. Legge ascended the East river, in the Kwang-tung province, in April, 1861, for a distance of 300 miles, and Rev. Mr. Irwin and his companions ascended the West river, in the same province, to a higher point than had been previously reached.

The Island of Formosa, hitherto sealed from European exploration, is now open; and a party of explorers have been traversing it during the past year.

The French conquests in the Empire of Anam (*see* COCHIN CHINA), have led to extensive geographical explorations in that empire; the Me-kong, or Cambodia, the Oudong, the Dongnai, and the Saigon rivers have been ascended for a distance of several hundred miles, and the populous cities on their banks explored. Pan-omping, at the junction of the Me-kong and Oudong, represented as one of the largest cities of Cambodia, was visited by one of the French ships of war. The principal islands on the coast, some of them large, and containing fine harbors, have been taken possession of by the French. Two English travellers, Messrs. King and Forrest, have explored the western portion of Cambodia, and made the circuit of the large and important Lake Tale-Sab, not hitherto found on most of the maps, on the banks and in the neighborhood of which they discovered extensive and remarkable ruins of two ancient cities, called by the natives Naken-Ouat and Nakon-Hluang.

Sir Robert Schomburgk, English consul at Bangkok, Siam, whose ascent of the Mei-nam river we mentioned in the "Annual Cyclopædia" of 1861, has contributed to Petermann's "Mittheilungen" a very full description of the course of the Mei-nam and of the productions of the regions through which it flows.

Rev. Francis Mason, D.D., an American missionary, of Toungoo, Burmah, to whom geographical and ethnographical science are already indebted for many important contributions respecting that country, has recently published, in the "Missionary Magazine," an account of a tour he has made in the interior of Burmah, where he has discovered two new tribes, of whom nothing except the names, and hardly these, had previously been known—the Paloungs and the Kakhyens. The former are a very intelligent race, evidently Mongolian in origin, Buddhist in religion, and, though tributary to the Burmese, yet maintaining a separate government. They are industrious, and their land is under good cultivation. They produce tea in large quantities, and export it to Burmah, Siam, and even to some of the Chinese provinces. Their language is peculiar, and bears no resemblance to that of the Burmese. The Kakhyens seem to be a branch of the Karen family, a simple-hearted race, who have no sympathy with the religion or language of the Paloungs, to whom they are subject. Some of

them practise a rude agriculture, while others are predatory and warlike in character. They resemble in many respects the Indian tribes of the Rocky Mountain regions.

Japan, so long impenetrable to Western nations, is becoming gradually the best known of any of the countries of Eastern Asia. The conquests and treaties of Russia are reducing the extent of its territory, the great island of Saghalien, the Kurile Islands, several of the important ports of Yesso, and the double island of Tsus-sima, the key of the Yellow Sea, having passed into the possession of that power within the past two years. Among those who have given much and important information relative to the climate, productions, manufactures, people, and political history of Japan, within the past few years, we may name Dr. D. J. Macgowan, an American medical missionary, who had unusual opportunities for obtaining information on these points, and who, since his return to the United States, has delivered courses of lectures on Japan; the Hon. Townsend Harris, late United States Minister to that country; Sir Rutherford Alcock's account of his residence in the island of Nippon, and his ascent of the volcano of Fusi-yama; Mr. Pemberton Hodgson, the English consul's narrative of his residence at Nagasaki and Hakodadi; M. Leon de Rosny's memoir upon Japan civilization; Messrs. Fr. Steyn and Hermann Wagner's *Nippon-Fahrer* ("Japanese Voyager"), with 140 plates and a map; and Dr. Petermann's account of the newly discovered atlas of Japan, published by native geographers, and containing 74 maps, and a general chart of the empire, on the scale of 1 to 800,000.

The Nicobar Islands, to the southwest of the coast of Siam, of which little save the names has hitherto been known, were explored by the Austrian exploring expedition in the Novara, and M. Brullé has given an interesting account of them in the *Annales des voyages*. The Andaman Islands, lying north of these, have been used since 1859 by the British Government as a penal colony for the revolted sepoys.

The enterprising English engineers Thuillier and Montgomerie, whose explorations in the Himalaya range we recorded in the "Annual Cyclopædia" of last year, have continued their labors in Cashmere and Ladak, and have discovered within 16 miles of the lofty peak K. 2 in the Karakorum range, a group of mountains, all of them exceeding 26,000 feet in height. Dr. Hooker, the English botanist, who accompanied them, has made public his observations on the botany of Sikkim.

The historical geography of Hindostan has been the subject of some important and interesting investigations during the year. M. Vivien de St. Martin has published an able essay on the India of Ptolemy; M. Reinaud, in an essay on Mesène and Kharacène, has settled the question of the situation of the ancient cities of Bahmanabad and Minnagara, which

till now had remained undecided, and has determined the epoch of the author of an ancient treatise on the Ruddy Sea (the Indian Ocean), which he assigns to the 8d century.

Capt. Cameron has communicated to the "Royal Geographical Society" of London an elaborate account of the ancient history, ethnology, and physical geography of the Transcaucasus.

The expedition of Mr. O'Hara Burke to explore the interior of Australia and cross that island continent, whose failure was chronicled in the "Annual Cyclopædia" for 1861, turns out to have been one of the most tragical and distressing of the many unfortunate enterprises for geographical exploration. Burke had unwisely divided his force into three or four companies; of these, Messrs. Purnell, Wright, and Ludwig Becker, with several men, were left at Menindie, and Mr. Brahe, with others, at a point near Cooper river, while Burke himself, accompanied by Wills, King, and Gray, with 6 camels, a horse, and three months' provisions, pressed on toward the Sturt-Eyre river at the north. On the 21st of April, Burke not having arrived at Cooper river, Brahe with his men abandoned that post only nine hours before Burke reached it, and left a writing behind, saying that he was in fine health and his animals in good condition. The company left at Menindie had suffered terribly from scurvy, Becker and Purnell with most of the men having died. Burke had at first made rapid progress, but soon came upon a waterless region where his camels perished and the provisions rapidly diminished. Gray soon died from exhaustion, and Burke and King, finding starvation impending, started in search of food, while Wills, exhausted, made his way to Cooper's Creek, a branch of Cooper river not far distant, where he died soon after. Three days later, Burke, worn out with fatigue and starvation, died, and King alone remained. Reaching Cooper's Creek in a condition of great exhaustion, he found the dead body of Wills, and wandering in the vicinity in a half delirious state, he fell into the hands of the natives, who treated him kindly, and, when he was recovered, gave him his liberty, and on the 25th of May he reached Melbourne.

The most enterprising and successful of Australian explorers, Macdonald Stuart, has, after a third attempt, succeeded in crossing the Australian continent from south to north. After a journey of eight months he arrived in safety at the port of Victoria, the most northern point of the continent.

Mr. Kinlay, sent out by the South Australian Government to search for Capt. Burke while his fate was yet unknown, made some interesting discoveries. Traversing a country more fertile than most of the interior districts of the Australian basin, he came upon a lake hitherto unknown, near which were several *tumuli* containing the bones of Europeans who had evidently been massacred by the natives.

At first he thought them the remains of Burke's party, but was soon convinced that this was an error; and as no party of such a number was known to have been murdered, he was left in doubt. The lake he named Lake Massacre.

In New South Wales, Capt. Randall, in command of the frigate *Gemini*, has ascended the Darling river, an affluent of the Murray, to Walgate, a village within sixty miles of the boundary of Queensland, passing through a region hitherto unexplored.

Dr. Seeman, who was sent out by the British Government to examine the climate, productions, &c., of the Fiji Islands, the inhabitants of which desired their annexation to Great Britain, has published his report. He states that the islands are volcanic and coralline in their origin, that they are remarkably free from all forms of malignant fevers, and so fertile that, though very indifferently cultivated, they support a population of 200,000. Sugar, coffee, tamarinds, tobacco, and cotton are cultivated with success, and among the native or naturalized productions are sandal wood in great abundance, four oil-yielding and five starch-yielding plants, four different spices, twelve edible roots, eleven potherbs, thirty-six edible fruits, and a vast number of medicinal, fibrous, scent-yielding, and ornamental plants and shrubs. The list of choice timber trees growing upon the mountains is very extensive.

The progress of geographical discovery in Africa has brought to light many new facts during the past year, but the great problems of the source of the White Nile, the conformation of the vast equatorial region, and the character of the tribes which inhabit it, are still unsolved, though each year brings us a little nearer to them. Beginning with the empire of Morocco, which, though not wholly unknown, has been little traversed by Europeans, we have four works published the last year which will throw much light upon its topography, people, and history. The Canon Léon Godard, who spent two years (1858 and 1859) in the northern part of the empire, has published an interesting narrative of his journeyings; M. Amédée Barbié du Bocage, the associate secretary of the "French Geographical Society," has compiled a résumé of all the known facts relative to the geography of the empire; M. Edward Schlagentweit, one of the Bavarian family of geographers who joined the Spanish army in its late war with Morocco (*see AFRICA*), has published a treatise on the ethnography of Morocco, and M. Beaumier has translated from the Arabic an interesting "History of the Sovereigns of Moghreb and Annals of the City of Fez."

Passing eastward through Algeria and the Barbary States, where some interesting archæological discoveries have been made, we notice that Commandant Mircher, chief of staff of the governor-general of Algeria, in the autumn of 1862, by direction of his chief, visited Ghada-

més, a town lying at the foot of the Black Mountains, in the extreme southwest of Tripoli, and on the 15th of December, 1862, concluded a treaty with the Touaregs, or Tuaricks, one of the principal Arab tribes of the Sahara, by which they bound themselves to convoy and accompany the French caravans in crossing the Sahara to Soudan.

Egypt offers nothing new or of interest geographically except the progress which is making in the completion of the Suez Canal, and thus reopening the water communication which once existed, though by a different route, between the Red and Mediterranean Seas. The source from which its great river flows, is, however, still the subject of as intense speculation as ever, and expeditions still fruitless in attaining their object have sought by approaches from the north and from the east to penetrate the secret of ages.

M. Lejean, who succeeded in penetrating to 4° 37' N., but was compelled to return, has published a report upon the antiquities, productions, and topography of Eastern Soudan and Nubia, which is full of interest, and has contributed materially to our knowledge of the region of the White Nile by carefully prepared maps and plans. In the "Annual Cyclopædia" for 1861 the death of Dr. Peney, who had reached 8° 30' N., was mentioned. His papers and collections in natural history and ethnography were carefully preserved and forwarded to the "French Geographical Society" by Espinasse Bey.

Two brothers, Messrs. Poncet, who have been for some years hunting in the region of the White Nile, have by their frequent communications to the "Geographical Society" rendered much service to geographical science. Several ecclesiastics of the mission of the Holy Cross, missionaries in Nubia, Fathers G. Beltrame, Morlang Kauffman, and Kircher, have made valuable contributions to the ethnography, philology, and geography of their districts. A corps of naturalists have made their headquarters at Khartum, and from thence have made several excursions which have been fruitful in scientific results. A proposition has been made and a considerable sum subscribed by these naturalists and other French geographers to place a small steamboat upon the White Nile, and ascend in it to a higher point than any yet reached, and thus prosecute the exploration.

In connection with this problem of the source of the White Nile, the explorations from the east through Zanguebar possess much interest. Rev. Dr. Krapf, who spent eighteen years as a missionary in that region, and to whom and his associate Rebmann we are indebted for the first knowledge of the existence of the lofty mountains Kenia and Kilimanjaro, lying between 1° and 4° S. of the equator, has returned to Mombaz to commence anew his explorations in the interior. The Baron Von der Decken and Mr. R. Thornton, formerly one of



Dr. Livingstone's associates, in the autumn of 1861 visited Kilimanjaro, and by a series of triangulations from Mombaz ascertained its height to be 21,000 feet. M. Beke has also explored this country very thoroughly, and has satisfied himself that these two mountains are only summits of a chain of mountains extending from the Southern frontier of Abyssinia to about the 8th degree of S. latitude, and which, though running N. and S. instead of E. and W., he supposes to be the real Mountains of the Moon. MM. Vivien de St. Martin and Robin, two French geographers, have also arrived at the same conclusions. In some portion of the Mountains of the Moon, and perhaps on the slopes of Mt. Kenia, it is probable, will be found the headwaters of the White Nile, rather than in Lake Nyanza, as Capt. Speke supposed.

Returning for a moment to Abyssinia, the topography of which has been published (prepared from actual surveys) the past year by M. Antoine d'Abbadie, we find that it has been visited by terrible earthquakes early in 1862, and an eruption of the Djebel Dubbeh, an active volcano near the eastern coast, which has destroyed and covered with ashes the town of Edd, situated on the Red Sea.

M. Henglin, a German traveller, already known by his discoveries in Northeastern Africa, has undertaken, sustained by a large subscription in Germany, to penetrate to Waday, the point where it is said the unfortunate Vogel died, and to recover, if possible, his papers, and to learn the circumstances of his death. For this purpose he has chosen a new route through Abyssinia, Upper Nubia, Kordofan, and Darfour. He left Abyssinia in the spring of 1862, but as yet there is no intelligence of his success.

Dr. Livingstone has prosecuted his explorations in S. E. Central Africa with unwearied zeal, but with not so large a measure of success as in former years. He ascended the Rovuma in 1861, which he hoped to find connected with Lake Nyassa, but being unsuccessful in entering the lake by that route, he explored the Comoro Islands at its mouth, and then returned to the Zambesi, where he revisited his old friends the Batoka and Makalolo, and in August, 1861, carried a boat past the Murchison cataracts in the river Shire, and launched it on the Upper Shire, which he found was a prolongation of the long-sought lake, though 60 miles below the entrance of the lake proper. He ascended the lake for 200 miles, and describes it as being in shape somewhat like Italy. It is about 225 miles in length, and varies in breadth from 18 to 60 miles, being widest toward its northern extremity. Its southern extremity, which is forked, commences in S. lat. 14° 25', and it extends beyond the 10th parallel S. Its course is nearly from N. to S. and it lies between the 35th and 36th meridians E. from Greenwich. Five considerable rivers flowed into it from the west, and one more, Dr. L. believed, from the N. The population along

its shores was very dense, and were maintained by the abundant supplies of fish in the lake and its tributaries. The traffic in slaves was very active. At one point he attempted to induce a tribe called Yawa to desist from slave hunting, and he and his party were attacked by them with poisoned arrows and guns, and compelled to use firearms in self defence. He returned to the Lower Shire in December, 1861, and in the spring, having received a steamer in parts from England, had it transported past the cataracts, put together, and launched upon the river, and in this he again ascended the lake in the spring, and was involved in some of the native wars, much to his regret and that of the members of the Oxford and Cambridge University Mission, who, under his guidance, had settled the previous autumn on the islands in the lake, S. of Mt. Zoruba, but who soon after this second visit abandoned the mission. Mrs. Livingstone, who had accompanied her husband on many of his perilous journeys, died on the river Shire in Africa.

Lieut. Rigby has contributed to the *Mittheilungen* a description of the states of the sultan of Zanzibar, and of the Island of Mombaz, which is under the protection of Great Britain.

A Portuguese geographer, the Viscount de Sa Bandiera, published in the summer of 1862 a map of the Portuguese states of Zambesia and Sofalla, with copious notes and explanations, which gives a better idea of the country watered by the Lower Zambesi and its affluents than any map previously published. This region is of interest not only from the discoveries of Dr. Livingstone, but from the missionary settlements planted in its southern part by the colonists sent out by Pastor Harms of Hermannsburg in Hanover.

The accession of Radama II to the throne of Madagascar (of which an account is given elsewhere; see AFRICA) has led to several exploring expeditions in that island, mostly of a missionary character. Mr. Ellis, a venerable English clergyman, formerly a missionary in the island, and driven from it by the fierce persecutions of the late queen Ranavalona, has returned there, and is now making a tour of the island. Several French Jesuit missionaries are also engaged in the investigation of the ethnology and language of the inhabitants. One of them, Father Deniaux, who had spent 18 years in the study of the Malagasha language, died in 1861, but left in manuscript a very complete grammar and dictionary of the language, which since his death has been printed by his native pupils.

Passing to the western coast, the new kingdom of Bihé, lying to the east of Angola and Benguela, has attracted some attention of late. Its king is a Hungarian, Ladislas Magyar, who has for many years resided in that country, and whose narrative of the inhabitants, productions, and history of the country he governs, recently published at Pesh, possesses great interest.

The region of the Gabun, whose exploration

by a French expedition was mentioned in the "Annual Cyclopædia" for 1861, proves to possess great interest. The narrative of the expedition throws much light upon the productiveness of the country in cotton, palm oil, coffee, &c., as well as in minerals. The natives of the Upper Gabûn are said to be a milder and more intelligent race than those of the coast. Incidentally, most of M. du Chaillu's statements are confirmed. An English explorer has also visited this region and spent some months among the people described by Du Chaillu for the purpose of ascertaining the truth of his narrative, and has communicated to the Royal Geographical Society the results of his investigations. In a few unimportant particulars he disagrees with M. du Chaillu, but most of his statements confirm the accuracy of that traveller's observations. Major Burton, the African traveller, now English consul at Fernando Po, has also visited the Gabûn country and sent to the Ethnological society an account of the Fans, whose habits and manners he had investigated; he also confirms the observations of M. du Chaillu. A live gorilla has been brought to London from this region.

In Upper Guinea, Dr. Baikie has been prosecuting his explorations in the region of the Quorra, and Major Burton has taken a part in the exploration; but much delay has been experienced in consequence of the unusual drought, which has made the streams very shallow. The English occupation of Whydah and Lagos has opened the way for new expeditions into Yoruba and the mountainous district lying from 70 to 120 miles from the coast, which seem admirably adapted to the culture of cotton, and are inhabited by an intelligent and partially civilized race. By the occupation of these ports, the slave trade has received a severe blow. The French have continued, during the past year, their explorations in *Senegambia*, and the coast of the Sahara lying between that country and Morocco. Lieut. Pascal visited Bambouk, but unfortunately fell a victim to the climate; and Lieut. Mage has spent a considerable time among the Dnaish, a Berber tribe hitherto unknown, and has given an interesting account of their customs and manners. A line of telegraph has been constructed from St. Louis, at the mouth of the Senegal, to Goree Island. The unicorn (not the one-horned rhinoceros), so long regarded as a fabulous animal, is believed, by recent explorers in Central Africa, to exist. Dr. Baikie has heard it described very minutely by native hunters, who carefully distinguished it from the one-horned rhinoceros, which it is said not to resemble. Dr. Baikie gives the native names by which it is known, and several other explorers express their belief in its existence.

**ARCHÆOLOGY.**—The study of the remains of antiquity, whether in its relation to history, ethnology, or civilization, has received an extraordinary impulse within the past two or

three years. Prior to the discoveries of lacustrine habitations and remains in Switzerland in 1854, it had been confined almost exclusively to the exploration of the relics of Roman, Greek, Assyrian, Egyptian, Indian, or Aztec and Toltec civilization, within the historic period, or at least within a period which had its records of some sort, hieroglyphic, hieratic, or pictorial. The discoveries of M. Ferd. Keller, of Zurich, and subsequently of Messrs. Uhlmann, Jahn, Schwab, Troyon, Forel, Rey, Desor, and others, of the remains of the dwellings, implements, weapons, &c., of two distinct races who occupied the shores of the Swiss lakes before the historic period, have awakened much interest, and led to extensive investigations in regard to similar remains in other countries. Some account of these discoveries in Switzerland and elsewhere is given in vol. xvi of the "New American Cyclopædia," p. 776, under the title of Lake Dwellings, and a more full and complete one in the Report of the Smithsonian Institution for 1861, pp. 844-896. It is only necessary to say here that these investigations have been continued with increasing zeal during the past year, many new lacustrine villages discovered, and considerable light thrown upon the fauna of the stone or earlier age.

Turning from these to other archæological discoveries of the past year, we find that in Egypt the late viceroy, Said Pasha, established a museum of Egyptian antiquities in Cairo in 1861, and as a nucleus for a collection, purchased Mr. Huber's (late consul general for Austria) fine museum, which had been many years in forming, and to this have been added large numbers of articles from other sources. During the year, a number of mummies richly decorated were found by some boys at Gournoro, in ground unmarked by any tomb. On being unwrapped, more than thirty-five pounds weight of gold ornaments, many of them richly jewelled, were found on these mummies; this unrivalled collection has been deposited in this museum. There are also some rare silver models of funeral boats, with the rowers, a hatchet of gold with a hunting scene on the blade, a mirror with a lotus-shaped handle of gold, necklaces, bracelets, &c.

In *Algeria*, *Tunis*, and *Tripoli*, many remains of Roman buildings, baths, temples, arches, inscriptions, lachrymatories, utensils for cooking and worship, have been discovered at Constantine, Krenig, Lambessa, Tebesor, Philippeville and Robertville. Besides these, a vast hypogeum has been discovered near Susa, and a great number of sculptures and other objects of antiquity at Cyrene. Lieutenants Smith, Porcher, and Carter, the discoverers of these last, have forwarded them to the British Museum.

M. Beulé, one of the librarians of the Imperial Library of France, has been engaged for nearly two years past in investigating the ancient site of Carthage, and has not only been able to trace the exact location of the Byrsa,

the walls of the peribola of the fortress, and a part of the wall which, on the eastern side, sustained the acropolis, but also many relics of the Carthaginian occupation.

The publication by the British Museum in 1861 of *fac-similes* of a number of the most important Assyrian and Babylonian inscriptions, carefully prepared by Major-Gen. Rawlinson, and E. Norris, in order to submit them to the examination of the most eminent decipherers, has led to some interesting results, and has served to place the interpretation of the cuneiform inscriptions on a firmer and more satisfactory basis. There is very little difference of opinion in regard to the proper reading of most of these inscriptions among the learned experts of England, Germany, and France, who have furnished independent translations of them.

The commission with which M. Ernest Renan was charged by the French Government in 1861 (*see FRANCE*), to investigate the antiquities, tombs, mausoles, temples, and dwellings of Syria, and report upon them, was one of great interest to archæological science, and the results of his explorations throw much light upon Phœnician history and character. The investigation was assigned to most competent hands, and the extensive explorations made by M. Renan show how heartily he entered into the work. In his report, published in the *Moniteur*, the past year, after stating that many of the so-called Phœnician antiquities are not Phœnician, but Roman, or even of the era of the Crusaders and Saracens in some cases, he lays down as a principle that the earliest Phœnician temples, tombs, and dwellings of which any remains exist have, as their distinctive characteristics, the use of stones of large size, without mortar or cement, of monoliths, and of works executed in the solid rocks or ledges, like the rock dwellings of Petra, &c. The most remarkable of these primitive structures are: the walls which surround the Island of Ruad or Aradus, which are constructed of huge quadrangular prisms of stone, from 16 to 20 feet in length, placed on bases of rock in position, hewn for their reception; the temple, courts, sepulchral pyramids, mausoleum, amphitheatre, and stadium, with the colossal lions and demi-sphere of Amrith; the sepulchral grottos and sarcophagi at Saida (Sidon); the two colossal lions, executed upon huge rocks, at Oum-el-Awamid; and several colossal statues and figures, some of them in bas-relief, at Kana, the gorge of Irapta, in the mountains of Lebanon, near Douair (this is a bas-relief of Baal and Astarte); at Gebell, Sabsakik, Neifed, and Ruad. Besides these, he discovered many statues, sculptures, temples, and dwellings of the Greek, Roman, and early Christian periods.

In all parts of Europe, archæological explorations have been prosecuted with great zeal and enthusiasm the past year. In Greece, the Archæological Society of Athens, as well as numerous English and French explorers,

have been actively engaged in the search for sculptures and edifices of the period of Grecian high art, at Athens, Corinth, at Oastri (the ancient Delphi), Salonica, Pydna, Philippi, Larissa, Pharsalia, Apollonia, Nicopolis, Cyrene, and Gortigna in Crete. These researches have been amply rewarded by the discovery of numerous statues, bas-reliefs, terra-cotta figures, and tombs adorned with sculptures illustrating many of the scenes described in the "Iliad." The foundations of several temples, hitherto unknown, have been traced, and in their ruins statues of great beauty have been found. These treasures of classic art have been deposited in the museum of the Archæological Society of Athens, in the Archæological Institute at Rome, in the British Museum, and in the Palace of Industry at Paris.

In Rome, M. Guidi has discovered a magnificent statue of Venus, near the Porta Portese, as well as an altar of Mars, and a statue of Bonus Eventus (Good Fortune). Several aqueducts and other indications of the direction of the ancient roads and watercourses of the city have been discovered by M. Rosa. The Emperor Napoleon III has purchased the Palatine Hill, in Rome, the site of the ancient Palace of the Cæsars, and has disinterred many relics, columns, pavements, mosaics, &c., of the ancient grandeur of that palace. In other portions of the city, other palaces have been discovered which have elegant bas-reliefs, representing scenes of sacrifice, &c. The excavations at Pompeii, under the new contractor, are proceeding with extraordinary spirit, and have brought to light several new dwellings, with frescoed walls of great beauty. At Herculaneum, also, excavations have been commenced on a grand scale, and have already resulted in the discovery of some fine statues in marble, especially two lions, evidently by a Greek sculptor. At Vulci, and Sclavi (the ancient Armentum), and Palestrina (Preneste), excavations have brought to light statues and monuments in bronze, of great beauty, and ornaments in gold and silver. Spain has also been seized with the archæological mania, and has discovered at Madrid a fine bust of Cæsar, a bronze statuette of a young Ethiopian at Tarragona, and a noble Hercules, also in bronze, at Almazaron, near Carthage. In France, the explorations made by order of the emperor, to determine the places mentioned by Cæsar in his "Commentaries" (the emperor, it is well known, is preparing a life of Cæsar), have led to some important results. Many relics of the Roman occupation of Gallia have been discovered, and large quantities of Roman weapons and armor, and, in several instances, statues and bas-reliefs. Numerous tumuli, mostly of Celtic origin, have also been opened, and the weapons, &c., buried with their owners, exhumed. It is said that these relics prove that in France the races which used implements of stone, and those which employed bronze knives, hatchets, arrows, &c., existed at the same time.

On the Western continent, the mounds and tumuli of the Northwest have received some attention, and the Smithsonian Institute has in hand a treatise concerning the ancient mining operations in the Lake Superior copper region, and has made arrangements for collecting specimens of the implements used in or about the ancient mines. The Institution has also sent out circulars giving instructions relative to archaeological investigations in the United States, and suggestions relative to an ethnological map of North America.

GEORGIA, the most populous of the extreme Southern States, had in 1860, 591,588 whites, 3,500 free colored inhabitants, and 462,198 slaves—total 1,057,286. The ratio of increase of the population during the preceding ten years has been: white 18.42, free colored 19.41, slaves 21.10. The white male population was 301,066; females, 290,484. The mortality during the year ending May 31, 1860, was 12,807. Fevers and pneumonia were among the most fatal diseases. The number of deaf mutes in the State was 428, of whom 88 were slaves. Of the industrial products of the State, the value of iron founding for the year ending June 1, 1860, was \$79,000; coal mined, 48,000 bushels; value of lumber sawed, planed, &c., \$2,064,026; capital invested in cotton manufacture, \$1,854,608; number of spindles, 41,312; looms, 1,058; value of leather, \$393,164; boots and shoes manufactured, \$357,267. Value of real estate and personal property, \$645,895,237; acres improved land, 8,062,758; do. unimproved, 18,587,782; cash value of farms and plantations, \$152,072,808. Horses, 130,771; asses and mules, 101,069; milch cows, 299,688; working oxen, 74,487; other cattle, 681,707; sheep, 512,618; swine, 2,036,116. Wheat produced, 2,544,913 bushels; rye, 115,582; corn, 30,776,293; oats, 1,281,817; rice, 52,507,652 pounds; tobacco, 919,316; cotton, 701,840 bales of 400 pounds each; wool, 946,229 pounds; peas and beans, 1,765,214 bushels; potatoes, Irish, 316,552; do. sweet, 6,508,541; barley, 14,682; cane sugar, 1,167 hogsheads; molasses, 546,770 gallons. Length of railroads in the State, 1,404 miles; cost of construction, \$29,057,742.

The commerce of the State being entirely cut off, and a general stagnation prevailing in business, the military affairs of the country became the engrossing topic with the people. The same sanguine confidence which had sustained their efforts during the first nine months of the war still existed at the beginning of 1862, notwithstanding the aspect of affairs was changing. Their enemy, the Federal troops, was concentrating in powerful force on the islands adjacent to the coast. Certain of the leaders of secession who were the senators or representatives of the State in the Confederate Congress, aware that an invasion of the territory was to be expected, had united in issuing an address to the citizens. See page

This address recommended them to destroy

their crops, especially cotton, and lay waste the country on the approach of the enemy. It was a confession of weakness, and recommended to the people of this once flourishing State a system of measures which they refused to adopt. Its effect, however, was to discourage the confidence of the people in the success of the war. Upon the call of President Davis upon the governor of the State, Joseph E. Brown, for troops, soon afterward, it was necessary to resort to a draft to obtain them. This draft took place in Savannah on the 4th of March. One military company of the city, the Mitchell Guards, was induced to volunteer toward making up the quota; but few others were added to the voluntary list. An immense crowd appeared before the officers on the day of the draft in Savannah and preferred their excuses. A large number of them were aliens, while others were invalids, all showing a disinclination to enter the army. In fact, at this time a large portion of those who had been in service refused to enlist, and a large party of the citizens of the State were dormant or indifferent as to the state of affairs. The same feeling existed widely in other of the Southern States. In central Mississippi most frantic appeals were made at this time to the lagging masses, while the people in the northern part of that State, like those in the same hilly latitude through Georgia and Alabama, were, from the first, largely Unionist, and waited as it was charged, "one-half to stare at, and the other half to welcome the approaching Federal forces." In other portions of the seceded States the same feeling existed. Even in South Carolina, upon a call of the governor for five thousand fresh troops, under the penalty of a draft, only nine reenlisted out of a regiment which had tried the war. The conscription act of the Confederate Congress was the salvation of the Confederate army in the year 1862.

The capture of Fort Pulaski, at the entrance of the Savannah river, on April 11, caused great excitement in the city of Savannah. A citizen has thus described it:

I can give you but a faint idea of the consternation the capture produced. Since the abandonment of the design by the enemy to bring in gunboats from Wall's Cut the confidence of the citizens became more assured, and the wisest hoped that the fort, which thereupon became the key and safety of Savannah, would be enabled to detain the enemy for an indefinite time. The blow has been suddenly and totally unlooked for, and equally unprovided for.

The enemy will not wait long to attack the batteries about Fort Jackson. Their heavy ships have entered the river above Pulaski as high as Venus Point, only seven miles below, and are in plain view of the defenses of the city of Savannah. How long they will be able to withstand an attack, let Pulaski be your teacher. We will be driven from them as surely as we now accept the fact of the loss of Pulaski.

The city has been in intense excitement between the bold and rapid advances of the Federals and the terribly unnerving taps upon the shoulder which the Brown satellites, under Gen. H. R. Jackson, without form of law or authority, inflict. Our citizens (the few who remain) have been arrested on the street, dragged to camp, shown a tent, and informed that there their

habitation should be. And this has been done by a parcel of beardless boys, who have been mustered into the State service.

Cotton has been removed, such as remained in store here, to the railroad. Ordnance stores and every variety of equipments have been thrown out and carted to the same receptacle for Government stores. Schooners have been seized, and some, already filled with earth, are ready to be sunk below, in common with the hulls of Com. Tatnall's fleet, which will never more venture beyond Savannah river. The Fingal, which now lies near Fort Jackson, is also to be sunk, and the gunboats—one of which is nearly ready for launching—will, if the enemy sooner advances, be given to the devouring flames. Women are leaving, and property of all kinds is being sent off, and will soon line the Central road from Savannah to Macon, rendering every log house a palace, if rosewood and satin damask can do it.

The demand for soldiers before the Confederate conscription act took effect was such as to cripple the manufacturing establishments so much that they could hardly fill the orders of the Government. As the Federal forces advanced to make their attacks upon the coast, at Brunswick and Darien, these towns were entirely abandoned by the inhabitants. (*See ARMY OPERATIONS.*) The defences of Savannah, however, were completed for the purpose of making a successful resistance whenever it should be attacked. They extended from the Savannah river, north of the city, to the Louisville road, thus making a circuit of earthworks. To supply the necessities of the soldiers, the governor, acting under authority from the Legislature, seized nearly \$350,000 worth of goods in Augusta, under a promise to pay at reasonable rates. To make up for the deficiency of weapons, the governor ordered twenty thousand pikes and bowie knives to be made. Distilleries were also ordered by him to be closed after the 15th day of March, throughout the State. The penalty on a refusal to obey this order was a seizure of the still, and its removal to the Government foundry at Rome, there to be manufactured into cannon. All liquor brought near military encampments was to be seized and emptied on the ground. In Fulton county, the grand jury were instructed by the Supreme Court to find bills of indictment against all foreign born citizens who had once exercised the right of citizenship and subsequently claimed exemption from military service in the Confederate army on the ground that they were subjects of a foreign government. The act was held to be a misdemeanor, or punishable by imprisonment in the penitentiary.

The conscription law of the Confederate Congress met with serious opposition in the State. In some of the northern counties it has never been executed. The governor took decided ground against its constitutionality. (*See CONFEDERATE STATES.*)

In the Legislature, at its session in November, the subject was referred to a joint committee of both Houses on Confederate relations. This committee made two reports. The majority report declared that Congress had no right to compel the citizens of the States to

bear arms except by a requisition upon the several States for their quotas, allowing each State to exercise such compulsion as might be necessary, and to appoint the officers for her own troops. It also recommended the adoption of the following resolutions:

*Resolved*, That all laws passed by the Confederate Congress to raise armies from the arms-bearing people of the States by compulsion, and without requisitions upon, or concurrent action of the States, are unconstitutional, and within our power to be declared void. While Georgia makes this declaration, she also declares her willingness and determination to furnish to the end of this unjust and wicked war which our enemy is waging upon us, as she has done from the beginning of it, all just quotas of troops that may be required of her in a constitutional way.

*Resolved*, That under the Constitution of the Confederate States and the laws of this State, all the troops which Georgia has sent to the field under requisitions from the Confederate Government, have the right to elect the officers who are to command them, and that the laws of Congress which deny or impair this right are unconstitutional, and in our power to be declared void.

*Resolved*, That while the foregoing resolutions express our fixed conviction, we are still willing to leave the conscript acts undisturbed in their operation, reserving to the State and her people such rightful remedies as may be demanded by future emergencies.

The report of the minority took the ground that the safety of the States demanded that no opposition should be made to any measures adopted by the Confederate Congress in the exercise of powers granted and intended for the common defence; and they recommended to the people of Georgia to acquiesce in the decision of the supreme judicial tribunal of their State, and the governor to countermand any and all orders which he might have issued to suspend the execution of these acts in the State upon the citizens subject thereto.

The Supreme Court of the State, on the 11th of November, decided that the conscription law was clearly constitutional under that provision of the Constitution which gave to Congress the power to raise armies, distinguished from the power to call out the militia.

The views of Gov. Brown were stated in a correspondence which took place at this time. Gen. Mercer, in command of the defences of Savannah, wrote to the governor on the 7th of November, stating that an order from the Secretary of War, received that day, withdrew from him all power to retain the negroes then working upon the fortifications of Savannah. Every one would probably leave him in a few days; he, therefore, made a requisition on the governor for fifteen hundred to work on the defences. The governor, in communicating this letter to the Legislature on the 10th, said:

I also append a letter from him dated the 8th instant, in response to one from me asking to make an urgent appeal to the Secretary of War to send to Savannah reinforcements at an early day.

It will be seen by reference to the first of these letters that the Confederate general looks to Georgia for the means to defend her seaport city.

While the right is denied to the State by the con-

scription act to call into the field and retain in her service any portion of her organized militia, or any part of the material of which it is composed, to defend herself against the invader at a time when the Confederate force within the State is inadequate to the task, the War Department has withdrawn from the general command the powers to retain the labor necessary to complete the fortifications which are indispensable to a successful defence. I submit the question to the action of the General Assembly, and recommend that prompt provision be made to the extent of the ability of the State for the carrying out your resolution for the defence of the city to the last extremity.

In view of the fact that Georgia has furnished about seventy-five thousand troops to the Confederacy, who have rendered the most distinguished services on almost every battle field of the war, I cannot forbear the expression of my deep regret that so few of them should be permitted to return to her bosom to strike for their homes at a time of so much peril, when the right even to supply their place in the field, upon her soil, with others now at home, is denied to the State.

Three days later, on the 18th, the governor sent to the Legislature another communication, accompanied by a letter from Col. Henry H. Floyd, of Camden county, complaining that on the 4th of November three companies of negroes landed at St. Marys, and after insulting the few ladies remaining there, and perpetrating many thefts, retired to the gunboats without the slightest molestation. On the same day all the salt works in the county were destroyed. Col. Floyd asked for an order to call out the militia for three or six months. Adjoining counties on the coast could add to those in Camden county sufficient to make a considerable force, who, being well acquainted with all the localities, could make a better defence than strangers. The governor also adds, as follows:

It cannot be denied that the State owes it to her citizens, so long as she claims their allegiance, to afford them all the protection in her power.

The Constitution of this State having invested me for the time with the chief command of her militia, I should, under ordinary circumstances, have had no hesitation in issuing an order calling out the whole militia of the county, and of the adjoining counties, if necessary, to protect our citizens, and especially the women, against the outrages of invasion; robbery, and insult by negroes.

Under the acts of the Confederate Congress, and the late decision of our Supreme Court, the authority to command the militia of the State, even for the protection of our mothers and wives, our sisters and daughters, against the brutality of our own slaves in a state of insurrection, seems to be denied to the Governor, as each man composing the militia of the State, except the officers, is declared to be subject to the command of the President without the consent of the Executive of the State. It follows, therefore, that if the Governor should order out the militia in this pressing emergency, which admits of no delay, to protect those citizens of Georgia to whom no protection is afforded by the Confederacy, the President may countermand the order, and compel each person so called out to leave the State and go to the utmost part of the Confederacy to protect those who are not citizens of this State. The State has reserved to herself the right under the Constitution to "engage in war" when "actually invaded," and to "keep troops" while she is invaded. That authority which has the right to take from her this power, without which no State can exist, has the power to destroy her.

I believe it is admitted, however, by high authority in this State, that the creature has no power to destroy

the creator, the child no power to destroy the parent, and the parent no right to commit suicide. If this be true, the Confederate Government, which is admitted to be the creature of the States, can certainly have no power to deny to the States, which are the creators, the use of their own militia to protect their own inhabitants against the invasion of the enemy, and unbridled, savage cruelty of their slaves in actual insurrection; nor can that Government, as the child, destroy the parent by paralyzing her right arm when raised to ward off a blow struck at her very vitals; nor, indeed, can the parent, which is the State, commit suicide by surrendering the command of her entire militia when she is invaded, and her people are left without other sufficient protection, nor by removing her obligation to protect her citizens, and thereby forfeiting their allegiance.

Placed as I am in this embarrassing condition, when helpless innocence calls upon the State for protection, and when the Constitution of this State and the Confederate States seems to point clearly to the path of duty upon the one hand; but when the acts of Congress, and the decision of our own Supreme Court, rendered under heavy outside pressure, and, if not *ex parte*, under most peculiar circumstances: when the counsel on both sides, who had brought the case before the Court, agreed that in their individual opinions the decision should be as it was made, I deem it my duty to submit the question to the General Assembly, who as a co-ordinate branch of the Government represent the sovereign people of the State, and to ask your advice and direction in the premises.

If you should hold that the Governor no longer has the right to command the militia of the State for the protection of her people, it only remains for me to inform the people of Camden, and the ladies of St. Marys that, while the State collects taxes and requires them to bear other public burdens, she withdraws her protection from them, and leaves them to the mercy of negro invaders, who may insult and plunder them at pleasure. Should you hold, on the contrary, that the Governor still has the command of the militia of the State, and that she has the right to use her own militia for the protection of our homes, I shall not hesitate to call them forth, and to hold them in service as long as the coast is invaded, and our people are subject to the insult, robbery, and merciless cruelty of the enemy.

The action of the Legislature upon the subject resulted in the adoption of the following resolution:

*Resolved*, That the Governor be and he is hereby authorized to call out such parts of the militia as he may think necessary to protect the citizens of Camden county, and other counties on the coast similarly exposed, against the invasion being made by companies of negroes, sent by the abolitionists to make raids upon our citizens, and to continue them in service as long as the emergency may require.

The Legislature also passed resolutions authorizing the governor to contract for slave labor to complete the defences of Savannah; if it could not be obtained by contract, he was authorized then to impress slaves for the purpose. It also appropriated two millions of dollars to relieve the families of soldiers who had enlisted from the State into the Confederate service.

The term of the governor, Joseph B. Brown, expires in November, 1868. The election for State officers is held on the first Monday in October, once in two years. The governor had been reelected to a second term. The senators from the State to the Confederate Congress in 1862 were John W. Lewis and B. H. Hill. The former having been appointed by

the governor to fill the vacancy, it became the duty of the Legislature at its session in November to elect a senator. The names voted for were very numerous, being thirteen on the first ballot. Among them were ex-Gov. Herschell V. Johnson, who was a candidate for the vice-presidency on the ticket with Stephen A. Douglas for presidency in 1860; Judge Jenkins, who a few days previous had delivered the decision of the Supreme Court of the State in sustaining the constitutionality of the conscript act of the Confederate Congress; ex-Senators Toombs and Iverson, late of the U. S. Senate; Howell Cobb, ex-Secretary of the Treasury, and Mr. James Jackson, formerly a member of Congress. Of 190 votes cast, Mr. Johnson received 84; Mr. Jackson 59; Mr. Toombs 24; Judge Jenkins 9; Mr. Iverson 8; Mr. Cobb 6, &c. A new ballot was ordered. Before taking the vote Mr. Whittle, of Bibb county, said he was in favor of sending a man to the Confederate Senate who would not be opposed to the Administration, and who would support and sustain the Government in this trying hour. His first choice was ex-Gov. Johnson, a man of unsurpassed abilities and patriotism; but he had understood that he was not in favor of the conscription law, and he could not vote for any man who was not in favor of that law. He referred to a letter from Gov. Johnson, which he understood the representative from Baldwin (Mr. Briscoe) had, and in which his views were defined. He called on the friends of Messrs. Jackson and Johnson to let the General Assembly know how they stood on these important points.

Mr. Briscoe, of Baldwin, said the letter from Gov. Johnson, which had been alluded to, was strictly private. He had shown it to a very few persons, not having the least idea that it would ever be alluded to publicly in any manner, and he greatly regretted it. He said he knew Gov. Johnson to be no seeker after office; that he was actuated by no consideration but patriotism, which burned as brightly in his breast as any man's; but yet, with this knowledge, he (Mr. Briscoe) would never have voted for him unless he had known him to be in favor of sustaining the Administration to the fullest extent in the prosecution of the war; and could not have voted for him or any other man who would oppose the execution of the conscription law. Mr. Briscoe therefore wrote to Gov. Johnson, and had received a letter in reply, an extract from which he read, the purport of which was that he believed the conscription law to be unconstitutional; but since the Supreme Court had otherwise decided he counselled acquiescence in its execution, and further counselled a most earnest and undivided support to the Government, and every measure thereof, in the support of the war, till the stars and bars waved in triumph over the Confederate States.

The next ballot was then taken, in which Johnson received 111 votes; Jackson 40; Toombs 14; Jenkins 2; Iverson 1, &c. Ex-Gov. Johnson was elected.

The manufacturers of cotton goods in the State, who composed the Manufacturers' and Free Trade Association, met at Augusta during the session of the Legislature, to fix upon some rate of compensation which they should receive for goods furnished to the State and Confederate States. The subject of the cost of the production of cotton goods was fully discussed by the convention, and a committee was appointed, with instructions to report upon the estimates presented by the various factories in regard to the actual cost of the production of those goods. The report of this committee was embraced in the following preamble and resolution:

*Whereas*, the Manufacturers' Convention, after comparing notes as to the immense advance upon every article in use pertaining to the cost of producing goods, viz.: Cotton, labor, oil, alcohol, varnish, gums, leather in its various uses, card clothing and hand cards for stripping cylinders, steel, iron, files, hardware, shuttles, bobbins, reeds, steel travellers, steel spindles, tin, Rabbit's metal solder, nails, screws, and a thousand other articles largely in use, most of which have increased over 1,000 per cent. in value, and some extend to the fabulous advance of 10,000 per cent., therefore, be it

*Resolved*, That the Manufacturers' Convention consider, from actual estimates presented, the present cost of production of cotton goods to be equal to fifty cents per pound, and deem it unsafe to bargain with Government at any fixed price to extend beyond one month, without the establishment of a sliding scale, by which the price may be varied from month to month, as the cost of production may advance.

These views were submitted to the Legislature for their approval in future contracts.

On the 19th of November the first General Council of the Protestant Episcopal Church in the Confederate States assembled at Augusta. The Rev. Dr. Henckhill, of South Carolina, was elected permanent president, and Rev. Mr. Mitchell, of Alabama, permanent secretary.

The crops throughout the State, especially the southern portion, were very good. The average of cotton planted was about two acres to each planter.

**GREAT BRITAIN**, a limited monarchy, reigning sovereign, Her Majesty Alexandrina Victoria, Queen of Great Britain and Ireland, born May 24, 1819; succeeded William IV June 20, 1837; crowned June 28, 1838. Area of Great Britain and Ireland, 112,190 square miles. Population, 1861, 29,081,299. Revenue for year ending Jan. 1, 1862, \$382,142,639; expenditure for the same year, \$342,759,406. National debt, Jan. 1, 1862, \$3,871,757,066.\*

The death of H. R. H. Prince Albert, Prince Consort, on the 14th Dec. 1861, wrapped the whole British kingdom in gloom. He had not been personally so popular as the queen, but the strong affection which had existed between the royal pair, and the overwhelming grief manifested by the queen at his loss, aroused the hearty sympathy of the entire nation. Parliament, which assembled on the

\*In this reduction of the revenue expenditure and debt to dollars the pound sterling is reckoned at \$4.84, the par value of gold.

6th of February, was opened by commission, the queen being too deeply affected to open it, as usual, in person, and by common consent party hostilities were laid aside, and although the position of the ministry, at the close of the preceding session, had been extremely precarious, yet the leaders of the opposition felt unwilling to incur the odium of defeating the ministry, and bringing the care and anxiety of the formation of a new cabinet, and the ordering an election of a new House of Commons upon the sovereign, while thus borne down with sorrow.

Thus it happened that the measures of the Government in regard to the Confederate Commissioners, Mason and Slidell, were approved with but slight dissent; the resolutions offered for the recognition of the Southern Confederacy were, at the request of the premier, withdrawn by their movers; the budget of the chancellor of the exchequer, though including important modifications in the collection of revenue, passed both houses by a large majority; and other bills which, under other circumstances, would have excited earnest debate, if not a disastrous division, were permitted to pass with but little difficulty. It was not until late in the session that any measures leading to heated debate were introduced. In the latter part of May, Mr. Stansfeld, a radical member, introduced a resolution condemning, in strong terms, the large military expenditure of the Government, and censuring the ministry for acting as alarmists. There were indications that, if brought to a vote, this motion would be carried, and Viscount Palmerston, always fertile in expedients, and knowing the indisposition of the conservative party to compel a change of ministry at that time, took the bold position before the house that the pressing of that motion would be regarded as a vote of want of confidence by the ministry, which would of course lead to their resignation, and thus compelled the opposition to withdraw the motion. The battle of the Merrimac and the Monitor also gave rise to warm discussion, in which the ministry did not escape wholly undamaged. The Government were constructing a considerable number of iron-clad ships, but they were all of very large size, most of them built wholly of iron, and possessing but moderate speed; while for coast and harbor defences they relied either upon their wooden ships, which the battle seemed to prove were worthless, or upon forts built upon land, which a well-protected iron-clad might pass with impunity. The opposition demanded that the Government should desist from their immense expenditure for forts, and build, for coast and harbor defences, vessels analogous to the Monitor. A Captain Coles, who had three years before proposed something of the sort (though with an iron shield rather than a turret), and whose plans had been rejected by the Government, now brought them forward again, and, under the clamors of the opposition, the Gov-

ernment were compelled to contract with him for the construction of several vessels on his plan, and to postpone the construction of further fortifications at Spithead. The fortifications at Portsmouth and Plymouth were in progress, and would need further appropriations for their prosecution; but, in the existing temper of the house, the premier preferred to delay as long as possible the discussion of these appropriations, which the war minister reduced to the lowest possible sum. The cabinet did not, however, escape a severe attack from Mr. Cobden, the leader of the radical, or Free Trade party, who accused the premier of causing vast and needless expenditure to the nation by constantly exciting apprehensions of a war with France, the futility of which no man knew better than himself; and averred that he thus speculated on the fears of the people, in order to maintain himself in power. Viscount Palmerston replied with great bitterness, and with such caustic personalities as greatly irritated the Free Trade party, and led Mr. Cobden, in a dignified but severe reply, to announce the withdrawal of himself and his friends from the support of the administration. Thus threatened, the premier was compelled to accept an amendment offered by the Conservatives to the Fortifications Appropriation Bill, interdicting the Government from exceeding in any way the expenditure named in the bill, and from undertaking any new work which would involve further expenditure. Humiliating as this deprivation of all independent action was, the Government had no alternative but submission. The Government also experienced a defeat in regard to a measure which it had offered for the relief of the parishes in Lancashire, Derbyshire, and Cheshire, where the cotton famine had thrown a large number of operatives out of employment, and greatly increased the number dependent upon parish aid. The bill presented by the Home Secretary provided that when the poor rates of any parish exceeded 5s. on the pound, the parish should have the right to require assistance from the other parishes belonging to the Poor Law Union till the poor rates of the entire union were brought up to this maximum rate. This was opposed, and finally defeated, by the members from the manufacturing districts, who urged that the parishes should rather be allowed to contract loans for the amount needed, to be paid in instalments from the proceeds of the poor rates in subsequent years. An act was subsequently passed providing that when the parish expenditure for poor rates exceeded 8s. in the pound per annum for the ensuing year, the guardians might charge the excess to the other parishes of the union until all the parishes had reached the limit of 8s. in the pound, when the guardians might apply to the Poor Law Board for permission to borrow money to meet the necessary excess, to be charged to the common fund of the union; and if, in the distressed unions, the expenditure ex-



ceeds the rate of 5s. in the pound, they might apply to the Poor Law Board, who could make a general order on the unions of the county to contribute to the aid of the union thus distressed. The act is limited to the counties of Lancashire, Derbyshire, and Cheshire, and expires the 1st of March, 1868. The session was closed on the 7th of August, with an address, as usual, from the throne, in which Her Majesty avowed her determination to continue to observe a strict neutrality in regard to American affairs, and discussed in general terms matters appertaining to the state of Europe, and the condition of the suffering operatives in Lancashire.

The diplomatic intercourse between Great Britain and the United States (*see* DIPLOMATIC CORRESPONDENCE) during the year has been courteous and friendly; but the U. S. Government has felt aggrieved at the persistency of the attempts of English merchant vessels to break the blockade, and at the construction in English dockyards of several vessels for the Confederates, intended to prey upon American commerce. There is no reason to believe that these vessels were thus built and fitted out by the connivance or tacit permission of the British Government, but the position taken by Earl Russell, that the case was similar to ours in 1855 when war vessels were built for Russia, (*see* DIPLOMATIC CORRESPONDENCE,) was such as to render that Government nearly powerless to prevent the construction of such vessels on British territory.

In the cotton manufacturing districts, especially in the counties of Lancashire, Derbyshire, and Cheshire, the continuance of the war in this country and the consequent scarcity and greatly enhanced price of cotton led to the stopping of most of the mills, and entailed a terrible amount of suffering upon the operatives.

Lancashire has been for many years the principal seat of the cotton manufacture. The number of persons directly occupied in the various branches of the cotton trade in that county is said to be about 400,000, and at least 400,000 more are dependent upon it. The average wages of an operative, taking children and adults together, were 10s. 8½d. or \$3.49, which would amount to \$996,232 per week, or \$51,560,520 per annum. The number of spindles was estimated in 1859 at 28 millions, and the number of looms at 800,000. The capital invested in that county alone in the cotton manufacture was about \$250,000,000. Of the 400,000 operatives usually employed, Mr. David Chadwick of Manchester, a careful and accurate observer, states, that in October, 1862, 150,000 were entirely out of employment, and 120,000 more were working on short time, not exceeding 3 days in the week. This would be equivalent, so far as loss of wages was concerned, to 60,000 more entirely unemployed. The entire loss of wages amounted to £105,000 (\$508,200) per week. It was expected that by Christmas the number, including trades dependent upon the

cotton manufacture, would be doubled, and a loss of wages equivalent to \$1,000,000 per week would ensue. Of course it was out of the question for such a sum to be deducted from the earnings of a laboring population of 400,000, weekly, without inducing very soon terrible suffering. That this suffering was not sooner made public was due to the previous condition of the people. The operatives of Lancashire were, as a class, in much better circumstances than the manufacturing population of most old and densely populated countries. Working but ten hours a day for five days in the week, and seven hours on the sixth; men of ordinary ability and industry would earn from \$5 to \$10 a week, while skilled mechanics often received \$15 or more. Women earned from \$3.75 to \$4.50, and boys and girls of 13 to 16 years from \$1.75 to \$2, while still younger children, who were obliged by law to spend half the day in school, would earn from 25 to 62 cents per week. It resulted from these liberal wages and the constant employment which up to July, 1861, these operatives had had, that they had been in circumstances of material comfort and, in some sort, independence for some years. This comfortable condition had been greatly enhanced by the very general diffusion of education among them by evening schools, scientific lectures, and a cheap but instructive literature. It was not a remarkable thing for a workman to rise from the masses to a position of responsibility and liberal remuneration; and not very rare for one to become himself an employer. Savings banks, temperance and teetotal societies had also done much for them. The use of intoxicating liquors had greatly diminished within a few years in the principal manufacturing towns, and reading rooms and libraries had taken the place of gin palaces. Thrift naturally followed from temperance and intelligence, and within the past ten years coöperative associations have made great progress in the manufacturing towns of Lancashire. There were at the commencement of the famine, about 100 of these associations in the county, with an aggregate capital of over \$1,000,000, and doing a yearly business of about \$5,000,000. Most of the more intelligent operatives who were heads of families were members, and had either put their small excess of earnings monthly into them, or had left their share of the profits after a first subscription to accumulate. Through the stores thus established they had been able to obtain better food and clothing for a smaller sum, while they shared in the moderate profits of the business. In some instances, as at Rochdale, the Coöperative Society has not only supplied its members with goods and provisions, but has erected mills for the manufacture of flour and meal, and finally has undertaken the manufacture of cotton and woollen goods.

The operative who had laid up his little savings in these societies or in the savings banks, had a small capital which, though not intended to be expended for his support, yet served as a

resource in the first trying months of the cotton famine, and had the period of the deprivation of work been shorter, the greater part of the Lancashire employes would have bridged it over with their little reserve without assistance from abroad, and though the poor rates might have borne somewhat hardly on the property holders, we should probably have heard little or nothing of the distress in Lancashire.

But the distress has been in existence for a long period. The market for cotton goods had been glutted by an immense over-production in 1859 and 1860, so immense that even a cessation of production almost entire for a year and a half has hardly sufficed to reduce the stock below the normal quantity; and at the same time the raw material was rising in value, slowly at first, but soon more rapidly, until it surpassed considerably the price which could be realized for the manufactured goods, and, under the double influence of an overstocked market and excessive cost of cotton, the manufacturers, in the summer of 1861, began to work short time, and in September many of them closed altogether. The hope that this state of things would not continue, encouraged the people to bear up under the privation of labor and wages. Nowhere in England were there in ordinary times fewer paupers, or lighter poor rates, than in Lancashire. The poor rates in 1860 had not averaged, throughout the county, 6*d.* in the pound of assessment, and the paupers were mostly of the idle and dissolute class, so that the name of pauper had there an idea of degradation connected with it, which these thrifty work people could not endure. It was not then till their little hoards in the savings banks and their reserves in the Coöperative Societies were gone, and even their clothing and furniture, and the bijous and mementoes of a more prosperous time, were all disposed of, that they would consent at all to ask parochial aid, and even then such was their horror of being regarded as paupers, that many of them, when urged to seek such assistance, would reply: "Nay, but we'll clem (starve) first;" and some did perish from starvation rather than ask parish assistance. It was not till the summer of 1862 that the necessity for further assistance to these distressed work people became generally known, and the first measure adopted for their relief was that by Parliament, of which we have spoken, authorizing the poor law unions to borrow money and to assess the excess of their rates on the other unions of the county. This act, properly called the "Rate-in-aid Bill," has produced some relief, though it was some time before it could be brought into operation, and meantime the poor rates, in some of the unions, had risen to the unprecedented and unendurable sum of 10, 11, 12, and even 13 shillings in the pound, and this, too, when the property holders, on whom this burden falls, could not collect their rents in consequence of the distress of their tenants. It became evident that further relief must be afford-

ed, and while many of the mill owners paid small weekly sums to the operatives they could not employ, contributions were liberally made from all quarters to the amount, before the close of the year, of more than a million pounds (\$5,000,000). Yet, notwithstanding this munificent contribution, to which has been added, we are glad to say, nearly half a million of dollars from this country, the suffering has been and still is severe; indeed it cannot be otherwise when full half a million of persons, whose earnings, in prosperous times, were not less than \$1,250,000 a week, are wholly dependent upon charity for their support.

Under the wise influence of those who have been their true friends in this trying time, the girls and women, who are receiving aid, are gathered in sewing societies and taught to make garments for themselves and families, and perform other household duties, matters in which they had hitherto, from their constant employment in the mills, been somewhat deficient. The men frequent the reading rooms and working men's colleges to a far greater extent than the gin palaces. The probable supply of cotton for the present year, is not indeed sufficient to enable the mills to run more than half time, but with the enhanced price of cotton goods this may be sufficient to keep the operatives from starvation.

The other events of the year, whether relating to the external or internal policy of Great Britain, have not been of very great importance. The revolution in Greece excited the sympathy of the people and the Government, and although the agreement into which the three protecting powers had entered, could not admit of the gratification of the unanimous desire of the Greek people, that Prince Alfred (second son of Queen Victoria) should become their king, yet the British Government indicated its good wishes toward them by suggesting other candidates of a liberal character for the vacant throne, and by offering to the Ionian Republic, for many years under British protection, the opportunity of becoming a part of the Greek kingdom.

The overtures of the French Government, in the early part of November, for a joint offer of mediation in American affairs were declined, and the War Minister, Sir G. Cornwall Lewis, avowed himself opposed to any offers of mediation or interference.

In relation to Italy the Government confined itself to expressions of sympathy with the King of Italy, and a desire for the termination of the difficulties relative to the occupation of Rome; while the sympathy of the people for Garibaldi and their indignation at his being wounded and taken prisoner was very strong. The amnesty which was soon after proclaimed toward him and his followers was, not improbably, hastened by the suggestions of the British Government.

STATISTICS OF GREAT BRITAIN.—1. *Financial.* The gross amount of the revenue of Great Britain for the year ending Sept. 30, 1862, was

£337,273,014. The expenditure for the year was not made up, but there was a probability of a slight deficiency. Of the revenue, \$115,496,920 was derived from customs, \$34,264,400 from excise duties, \$42,712,734 from stamps, \$15,294,400 from taxes, \$38,773,480 from the property tax, \$17,230,400 from the post office, \$1,435,162 from the crown lands, and \$9,772,318 from miscellaneous sources.

The Bank of England is the principal though not now the only bank of issue of the United Kingdom. On the 20th of September, 1862, it had notes in circulation to the amount of £21,143,709; the Bank of Scotland, at the same date, had £3,987,290; the Bank of Ireland, £5,071,204; private banks £3,065,498, and the joint stock banks £2,795,424. The private banks, joint stock banks, and, we believe, the Bank of Scotland, pay out only Bank of England notes. The entire bank circulation of the United Kingdom of Great Britain and Ireland, at that date, was £36,068,125 (\$174,569,725). The coinage of 1861 was £3,536,000, or about \$42,000,000.

2. *Imports and Exports.*—The imports of the year 1861 were £217,315,881 (\$1,051,808,864); the exports for the same year were £125,115,133 (\$605,557,244). Of the imports £38,653,398 (\$187,082,446) was of raw cotton; of this, £26,570,399 (\$128,620,731) was from the United States; £34,741,692 (\$168,149,789) was bread-stuffs. The other principal articles were: wool, £9,366,296; raw silk, £7,907,162; sugar and molasses, £18,252,217; tea, £6,850,561; coffee, £2,628,694; butter, £4,902,394; flax, £3,423,187; tar, £3,811,717; timber, £10,270,566; wine, £3,862,233; flaxseed, £3,108,055; manufactured silks, £5,356,404; tobacco, £2,195,147. Of the exports, cotton goods took the lead, their value being £46,836,737; woollen goods came next, their value being £14,687,316; iron and steel (except hardware and cutlery) were valued at £10,341,574; machinery, £4,219,688; hardware and cutlery, £3,425,260; haberdashery and millinery, £3,423,493; coals and culm, £3,593,076.

The number of ships entering British ports from other countries in 1861 was 55,263 vessels, and their aggregate measurement 13,179,589 tons; of these, 29,907 vessels, measuring 7,721,035 tons, were British, and 25,356, measuring 5,458,554 tons, were foreign.

The clearances from British ports for foreign ports the same year were 56,056 vessels, with an aggregate measurement of 18,416,052 tons, of which 29,357, measuring 7,699,497 tons, were British, and 26,699, measuring 5,716,555 tons, were foreign. In the coasting trade the same year, 153,066 British vessels, with a tonnage of 17,357,181 tons, and 525 foreign vessels, tonnage 93,456, entered the several ports of Great Britain; and 156,931 British vessels, with a tonnage of 17,379,693, and 403 foreign vessels, tonnage 67,031, departed from those ports.

3. *Education in England.*—In England the Educational Committee of the Privy Coun-

cil report in 1861 10,900 daily schools, with 1,023,690 children (5 boys to 4 girls), 8,069 certificated teachers, and 15,498 apprentices or assistant teachers. There were also 39 training colleges with 2,369 students and 2,782 candidates for teachers; 442 schools for pauper children, with about 30,000 inmates, and 58 ragged or industrial schools, with 4,411 inmates. For secondary education, there are in England 20 foundation schools, in most of which the course of classical and mathematical instruction is nearly or quite equal to that in the majority of our colleges; there are also about 40 colleges, mostly though not entirely under the direction of dissenters, and all in connection with the University of London as to degrees, and the three universities, Oxford, Cambridge and Durham. The University of Oxford has 19 colleges and 5 halls, and beside the college headmasters and teachers, or dons as they are called, a body of 41 university professors. Cambridge University has 16 colleges and one hall, and a corps of 28 University professors. The University of Durham has one college and 2 halls, and 7 professors and readers and 3 tutors. In the way of higher education there are theological professorships connected with the universities and most of the dissenting colleges, 48 medical schools, instructions in law in the 4 Inns of Court (the Middle and Inner Temple, Lincoln's Inn and Gray's Inn), and professorships of law in King's and University Colleges, London, and in Oxford and Cambridge Universities; military colleges at Landhurst and Woolwich, a naval college at Portsmouth, a Government school of mines at London, a royal agricultural college at Cirencester, and a royal veterinary college at Camden Town.

4. *Postal Communication.*—In 1861, the number of letters delivered in the United Kingdom was 593,240,000, of which 486,679,000 belonged to England and Wales, 50,009 to Ireland, and 56,552,000 to Scotland; or 24 letters to each inhabitant of England, 9 to each inhabitant of Ireland, and 18 to each inhabitant of Scotland. The number of newspapers delivered was 72,300,000, and of book packets 12,300,000. The gross revenue was £3,665,128 (\$17,739,210), the expenditure £2,501,013 (\$11,804,908), and the net revenue £1,164,115 (\$5,624,007). The total number of miles over which the mails are transported during the year is 47,371,924, and the average cost per mile, 8½d. or about 7½ cents. The number of money orders issued in 1861, was 7,580,455, and the amount £14,616,348 (\$70,743,124). The profit to the Government was about \$130,000. Only £267 (\$1,292) has been lost in ten years. In 1861, the Government added to the Post Office Department a system of post office savings banks, on a very simple plan. This has found so much favor that on the 1st of April, 1862, only six months, there were 91,965 depositors, and the amount of deposits was £735,253 (\$2,558,625). The average amount of deposits to each depositor was about \$13.

**GREAT EASTERN, STEAMSHIP, *the accident to and repairs of.*** On the 27th of August the Great Eastern, while hove to—the propeller engines being in motion ahead and the paddle engines in motion aback, waiting for a pilot, came in collision with a submerged rock near the east end of Long Island. A large fracture was made in her outer skin, and a considerable list or careening took place from the entrance of the water between her skins, but the inner one being uninjured, she was brought to her anchorage near the city of New York. Her passengers, some without any knowledge of the accident, and her entire cargo, were discharged within ten days, without injury to a single article. The agents of the ship, Messrs. Howland and Aspinwall, called the engineers, Messrs. H. B. and E. S. Renwick, into consultation with Capt. Paton of the ship, and as there were no docks in the country of sufficient capacity to admit or lift her, it was decided to repair the injury by means of a caisson or scow, as in figs. 1, 2, with two entrance shafts extending from one of its sides upward a little above the surface of the water. To determine the form of the vessel at the fracture, in order to fit the gunwales of the caisson to it, the engineers proposed a species of adjustable template composed of a frame of timber of the same size as the intended gunwale of the scow, and having a series of sliding bars like fence pickets arranged around it, which could be moved perpendicularly to the plane of its surface to any desired positions. The frame was

to be ballasted sufficiently to sink it and to be drawn by ropes against the ship, at the place where the caisson was to be fitted. Then a diver was to be sent down to shove the bars toward the ship until their ends touched it and secure them by nails, so that when the frame was drawn up the points would present an exact counterpart of the ship. The only difficulty was that the whole work depended on the skill of the diver, and it was finally decided to take the moulds from the inner skin, which was supposed to be parallel with the outer one. To do this 600 tons of coal were moved from the bunkers over the fracture, to the opposite side of the ship. While these moulds were being taken inside the ship, the divers were busy on the outside, determining the exact size and position of the fracture, of which preliminary examinations had already been made, and also in surveying the bottom to see if other fractures existed. The ship was undergirded by a chain drawn tight beneath the bulkhead immediately aft the screw engines, the first bulkhead aft the fracture, and the inside moulds were referred to the same bulkhead. The length of the fracture and its distance forward from the chain were now measured by the divers with a line. As only each outside strake of the plating at the side of the ship was connected with the inner skin by a longitudinal partition, it was deemed necessary to locate the port gunwale of the caisson upon an outside strake where the pressure against the ship would be best sustained. On this account it became not only necessary to determine the

FIG. 1.

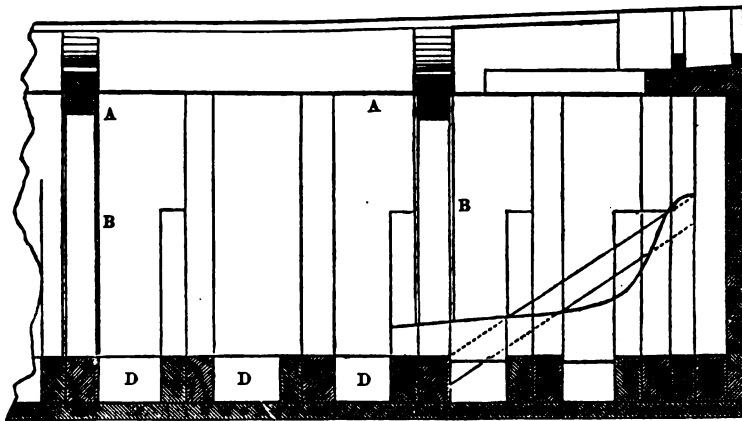

widths of the fracture, but also its position in reference to the strakes. The base for these measurements was the termination or line of the salmon colored strakes. This line was referred to the 30 ft. deck, as were also the inside moulds. A line with a hook at its end was carried down by the diver at every place where a measurement was made; it was hooked on to the edge of every outside strake and to the side of the fracture, drawn tight to the base line, and the distance noted. From the moulds taken from the in-

side of the ship, and the measurements outside, the lines of the ship were laid off on the moulding floor of the ship yard, the form of the fracture and indentation and the size of the caisson necessary to repair the injury determined. It was at first proposed to make the caisson of a rectangular section, but on consultation with the shipbuilder Mr. Van Deusen, it was decided to make the ribs curved. Fig. 1 shows a fractional longitudinal, and fig. 2 a cross section of the caisson, as it was constructed. In order

to distribute its pressure against the ship, it was built with a series of cross timbers AA, braced by shores BB. The lower sections of the entrance shafts were firmly secured to the caisson by knees and bolts. Each curved timber of the caisson DD consisted of 8 segments 8 inches broad, 11 in. deep, strengthened by 2 pieces 6 in. broad, breaking joints with the main timbers. The ends of the caisson, being flat, were strengthened by diagonal braces and knees. The planking was 4 inches thick, and the whole was thoroughly calked and pitched. At the suggestion of Capt. Paton, to guard against leakage, in case of change of form of caisson by twisting under the pressure, the outer surface of the caisson was covered with an old Brussels carpet secured by thin wooden battens. As it was necessary that the gunwale of the caisson should fit the ship, and as it was not be expected that this form could be determined accurately, the planking was of soft wood, and no diagonal bracing was used to interfere with the twisting of the caisson to adapt itself to the form of the ship. The entrance shafts F (fig. 8) were curved, as shown in the drawing, somewhat to the form of the ship, about 6

feet broad on the outside, lengthways of the ship, by 8 feet 9 inches on the inside crosswise. As it was necessary that these shafts should be about 85 feet long to be 6 feet above the draught line of the ship when in place, and as it was impracticable to attach them at the shipyard and float them 12 miles to the ship, they were made in two sections, and fastened together after the caisson was towed to the ship by bolts; a ladder was formed inside of each shaft for the convenience of the workmen. As said above, it was not expected that it would be possible to fit the caisson exactly to the form of the ship; some sort of adjustable packing would therefore be necessary to fill up any interstices, so that the water might be lowered in the caisson, and the pressure thus applied serve to twist the caisson and adapt it to the mould of the ship. In seeking for such a packing, the engineers conceived that the water tending to enter the joint at the gunwale might be kept out by a superior pressure of water in a hose around the gunwale. Accordingly an endless hose (h h, fig. 2) was made to fit a shallow groove on the gunwale of the caisson; this groove was made by nailing battens 2 inches thick upon the outer and inner edge of the

FIG. 2.

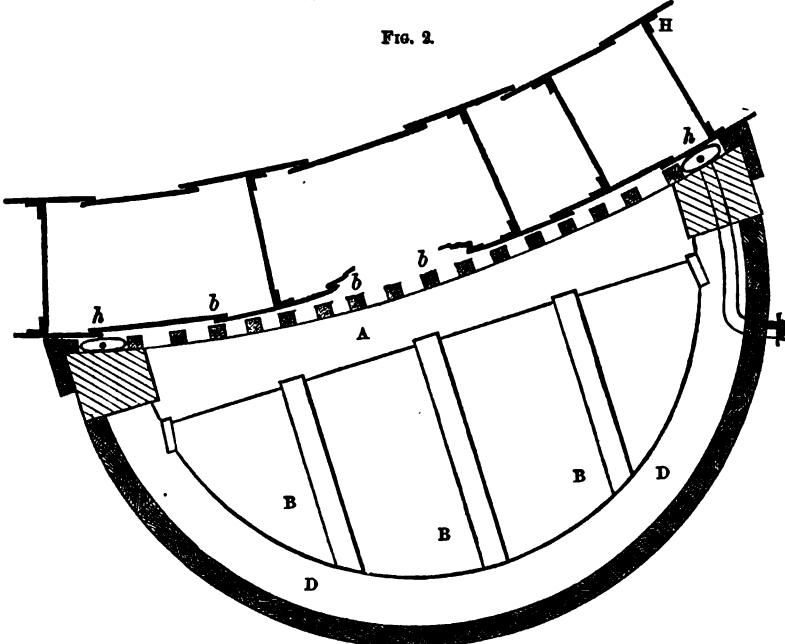

gunwale. The hose was made of 2 thicknesses of heavy cotton duck coated with beeswax, and was 9 inches diameter, as it was expected that the crack would not exceed 5 or 6 inches. In order to prevent the hose from being forced into the caisson by the pressure of the water, tending to enter over the gunwale before it was brought in contact with the ship, the hose was secured to the outside edge of the gunwale by passing bands of canvas around it and securing both ends of each band under the gun-

wale batten on its outer side. While the caisson was being lowered, the hose was held in the groove by a cross barring of rope yarn, that could be cut by the diver before the hose was distended. To prevent the hose from being squeezed so that the water could not pass through it at any point, a rope 1 inch in diameter was inserted in the hose while being made, to afford crevices for the water to pass if the hose was flattened. The hose was arranged to be supplied with water by means of smaller

hose—for fear of accident, two at each end. These were carried some distance above the water, and one of them was supplied by the ship's pumps discharging into it continuously, the surplus passing out of the upper end of one of the others. As a further precaution against the admission of water at the gunwale, there was a flap of Brussels carpeting four inches wide, the inner edge battened to the outside of the gunwale, and the outer sewn to a bolt rope to prevent it from being drawn into the joint. As the hose answered its purpose, there was not draft to hold the flap to the side of the ship. The caisson was built bottom up for convenience of planking, launched that way, and towed to the derrick at the Novelty Works and turned over, and then towed to the ship. To bring the caisson into position two heavy timbers were placed on the ship's deck, and projected over the side at the extremities of the caisson in position. Two heavy timbers were also placed in like manner for hoisting the entrance shafts. Blocks and tackle were attached to the extremities of these timbers, and connected with the caisson and shafts, and with the ship's capstan; chains, secured to eye bolts in the port side of the caisson near its ends, were carried down beneath the bottom of the ship, and were drawn up and secured by tackles at the starboard side of the ship; 2 chains led up to the davit tackle on the port side of the ship. To overcome the buoyancy of the caisson 26 tons of iron ballast were necessary, and the engineers determined to use chains for this purpose, as when the caisson was in position the chains could be drawn out through the entrance shafts readily, and the caisson would then be pressed against the ship by its regained buoyancy. To guide the caisson as it was lowered, and to have the means of determining readily when it was in position, a large log 4 feet longer than the caisson was ballasted and hauled under the ship by chains at each end until its port side, which would be next the caisson, was 18 inches to the starboard of the required position of the starboard gunwale. The position of the log laterally was determined by the length of the chains as let down from the port side of the ship; the log was let down a little ahead of its position, and then drawn endways according to the directions of the diver. Wire rope guides (*a*, fig. 8) had already been attached to each end of the log at a distance apart to admit of the length of the caisson between them, the loose ends of these ropes were brought up the port side of the ship and passed through eye bolts in the ends of the caisson to guide it as it was lowered into its place; the upper ends of the rope were secured to tackles at the extremities of the end davits, so that they could be slacked or tautened at pleasure. The ballast having been distributed in the caisson so that it floated at about the angle at which it was to be placed, it was filled with water by the ship's pumps, the

port chains being kept taut; when filled it sank and was lowered by the port chains to the proper angle to receive the upper sections of the entrance shafts, which had already been raised by the intermediate davits; the shafts were then lowered and connected with the nozzles on the caisson by bolts passing through their flanges. As soon as the entrance shafts were attached the caisson was lowered by slacking the tackles at the four davits until it had sunk a certain measured distance determined by the length of the port chains; as it sank it glided down the wire rope guides left purposely slack. Then the caisson was drawn laterally against the ship by taking up the starboard chains, and at the same time guided to its place by tightening the guide ropes. When in contact with the ship and nearly in position, divers were sent to report its progress, to see whether it covered the fracture, and whether its gunwale would come upon the centre of an outside strake. When drawn into its right position 4 heavy hawsers were placed under it and the ship, to cramp it against the ship; these were hauled tight by the ship's capstan; the chain ballast was then drawn out, another pull taken at chains and hawsers, and then to make a still greater strain wedges were driven between them and the sides of the ship. The caisson was held in its place longitudinally by 2 chains, one secured to an eye bolt in the front end of the caisson, and carried forward at the side of the ship, ahead of the paddle box; the other chain was attached to the rear end of the caisson, and carried aft into one of the stern hawse holes. As first arranged, the pump (Andrew's centrifugal) was secured in its place, at the end of the frame K, before the caisson left the ship yard, and an intermediate shaft attached before the caisson was lowered. The small hose was connected at the same time with the gunwale hose, and when the caisson was in position, a line was attached to the loose end by the diver, and it was drawn up. In order to permit the divers to examine the interior gunwale of the caisson, a foot board was secured to brackets around the caisson about 4½ feet from the gunwale; and at the suggestion of Capt. Paton, cords with knots corresponding to their distances from the forward end of the caisson, were attached at every fathom to enable the diver to ascertain his position by feeling. On examination the divers reported that the cross timbers of the caisson bore against the ship in certain places where the plates were bulged out, whilst at their ends the gunwale was not in contact with the ship's side. This had been foreseen, and blocks of soft wood (*b*, *b*, fig. 2) had been placed on the top of the cross timbers, which could be split out to bring the gunwale in contact with the ship. The cutting out of the blocks was a tedious job, and occupied considerable time, and was done by divers, one splitting out the blocks, whilst the other held a submarine lamp, and secured the chips and placed them in a bag, to prevent them from

getting between the gunwale and the ship. As the blocks were split out, the caisson came nearer and nearer to the ship. When all were taken out that prevented the gunwale from coming in contact with the plating, it was found that the gunwale bore at the ends of the

caissons, but intermediate there was a joint of about  $3\frac{1}{4}$  inches wide on the port side, and about 2 inches on the starboard side in the widest part. As this was satisfactory, the hose was filled and the pump was set at work, and worked continuously for 12 hours, discharging

FIG. 8.

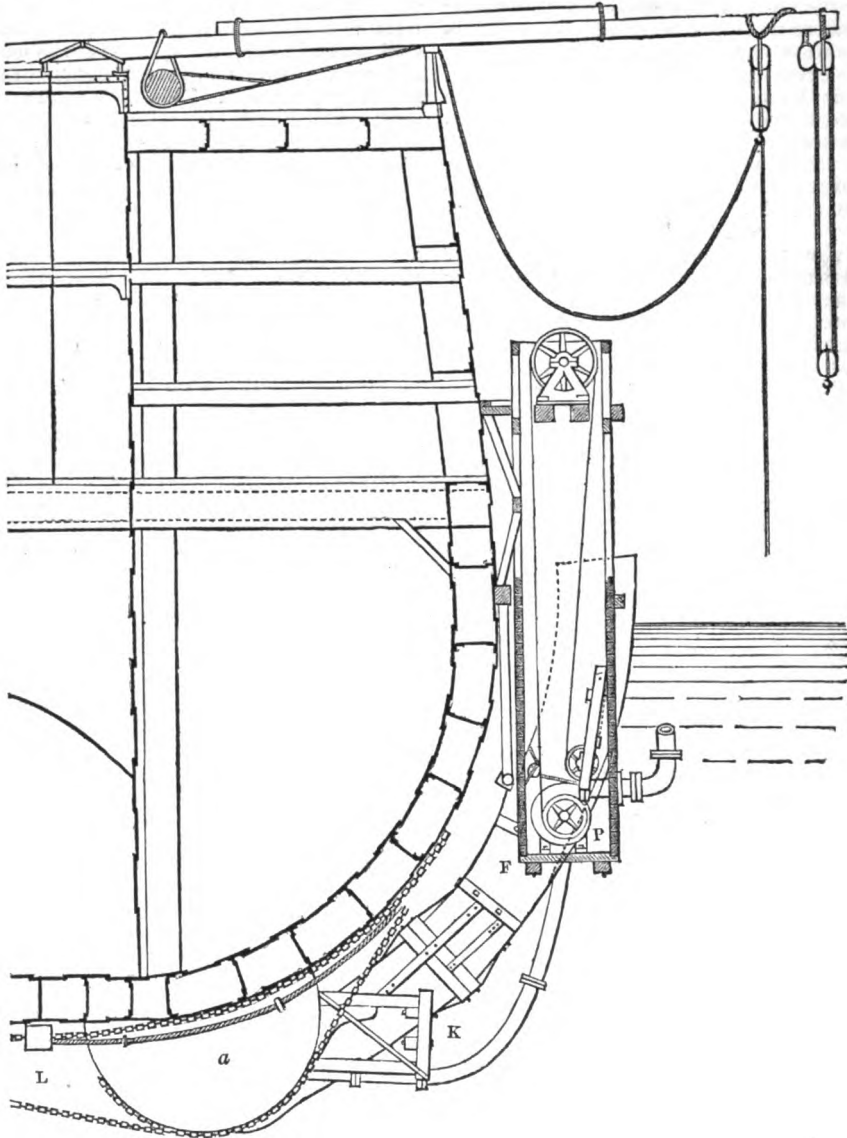

about 3,000 gallons, or about 13 tons of water per minute without lowering the water in the entrance shafts more than 18 inches. It was evident that the water came in about as fast as it was pumped out. The divers were sent down into the inside of the caisson, and reported that the water did not come from between the gunwale and the ship, but from the

interior of the ship. It was known that the space between the two skins was full of water, and that the water was draining into the caisson, but continued pumping made it certain that there was some other fracture in the outer skin outside of the caisson through which the water found its way into the ship, and then into the caisson. One such rent, about 11 feet

in length, and varying from a mere crack to 2 inches in width had been discovered by the divers on the first survey, and had been covered by a mat of rope; but on examination this mat was found sagged off, and the rent was now calked with a canvas sausage, stuffed with seaweed. The bilge pumps were now set to work to take the water out of the side where this rent was, and manhole plates were put in the fore and aft webs to cut off the passage of water from this rent to the adjacent sides. Meanwhile the Andrew's pump still continued at work, but the water did not lower in the caisson. Accordingly it became necessary to make a resurvey of the ship's bottom, keeping the pumps at work to cause a current to set in at every fracture, so that it might readily be found by the divers. The first examination had been made from a platform of ladders and spars ballasted, and suspended from the ship's sides, and beneath her bottom, and moved as required, by the crew on deck. In the re-examination the shifting of the scaffold was left to the diver. A plank about 40 feet long was used for a scaffold. This plank had 2 eye bolts inserted in its under side, at a distance of 10 feet from its ends. Through these eye bolts ropes were passed, which undergirded the ship. This plank could thus be shifted laterally on the ropes at the pleasure of the diver, and fastened by small ropes to the undergirders. Commencing forward, as soon as one section of the ship's bottom had been examined, the undergirders were shifted aft half the length of the planks, and so aft till the whole bottom was thoroughly examined. This examination took from October 20 to November 3, and discovered six other fractures in addition to the forward one and that beneath the caisson. These fractures varied in length from 8 to 24 feet, and from mere cracks to a separation of about 8 inches. All these cracks were stopped temporarily before the caisson could be pumped out, by a contrivance suggested by the diver, Peter Fallon, consisting of a frame of light wood, a little larger than the hole to be stopped, and lashing to this frame like the sacking of a bed sheet of India rubber belting; this belting was 12 inches wide, and to cover the biggest hole, it was necessary to use two strips lapped and riveted. As the rubber was placed over the fracture, the draft through the caisson when the pump was running drew the rubber close to the ship, and any joints or wrinkles in the rubber admitting water were chinked with sea weed. To secure the patches when the pumps stopped, flock mattresses, attached to light spars, were brought up against the patches by ropes undergirding the ship. By November 3d all the cracks were temporarily stopped, and the water began to sink rapidly in the shafts. As soon as it was down 6 feet below the outside level, the pump was run only fast enough to keep the water at this level, and the divers were sent down into the caisson and wedges were taken down in a bag, and driven between

the cross beams and the ship's bottom to distribute the pressure as uniformly as possible. Some delay and trouble were caused by the want of fresh water for the boilers driving the pump, which were placed on the deck of the ship; but at 5 p. m. the caisson was sufficiently freed from water to enable Capt. Paton and one of the divers to enter at one shaft and pass through the caisson, and out at the other. Next morning the engine driving the pump broke down, repairs were made, and the engine started again; but the gale of Nov. 7th now came on; the ship dragged her anchors, and had to be put under full steam. A large rope, which had been used as a guy, either by accident or design, got foul of the pump shaft, was wound up by it, and the shaft broken and the pump so disarranged, that it had to be removed and repaired; and as it could not be replaced by the divers, some new arrangement was necessary, and that shown in fig. 3, in which the pump is secured in the bottom of an upright box bolted to the ship's side, and driven by a belt, was adopted. The construction of this box and placing it in position occupied a week. Everything was ready to start on Saturday, the 15th, but no work was done till Monday, when the pump was started. The work of wedging the cross frames, arranging the patches and chinking with sea grass wherever a leak showed itself, had to be gone over by the divers. On Tuesday the captain and the chief engineer of the ship, Mr. Rorison, went through the caisson, and a man was set to drilling the first rivet hole. The engineers of the ship were sent into the cells between the skins, where they found the water running in a stream about 8 inches deep through one of the manholes in one of the longitudinal webs between the cells. This manhole was closed by a plank with a rubber facing, and secured by a shore. The carpenters were now set at work to make a scaffold for the drillers in the caisson, and the men at work to drill the rivet holes, under the direction of the engineers of the ship, and the dimensions of the necessary plates were taken, and the iron ordered. On November 23d all the holes were drilled, and the plates were arriving; but now the Andrew's pump began to show signs of weakness, and gave out, and the caisson began to fill. The ship's pumps were set at work in the compartment of the skin over the caisson, and kept the water from rising over ten feet in the caisson. The centrifugal pump was taken out, sent to the city for repairs, and returned the same p. m.; put in place and set at work by the next a. m.; then the engineers of the ship commenced to apply the plates and the riveters set to work, the hot rivets being dropped into the caisson through tubes arranged for the purpose. To guard against another accident, another pump, a Worthington, which had been previously recommended by the engineers, but, on account of economy, not adopted, was placed in one of the stoke holes, over the fracture. Steam



being supplied to it through a rubber hose from one of the ship's boilers, it discharged its water through one of the coaling ports, and was kept at work until the last plate was applied, steam being still kept up in the boilers of the centrifugal pump so that it might be set at work in case of accident. The work of applying the plates to the ship's side went on night and day, under the direction of the engineers of the ship, Messrs. Rorison and Beckwith. The fracture varied in breadth, being in some places 4 feet wide. To cover the indented plates, and restore the form of the ship, the patch of new plates was 98 feet long by from 6 to 10½ feet in breadth, ¾ inch thick, applied crosswise of the ship with lap joints. The work of applying the plates was commenced at the after end, the cross timbers were cut away to make room for the plates, and temporary shores were driven between the plates and the bottom of the caisson as the plates were put in place. Everything now went on quietly and rapidly. The job was completed, and, on inspection by a number of engineers and nautical men, was deemed very satisfactory. The accident has demonstrated in a most practical manner the value of the cellular system of construction. The outer skin was so abraded, torn, and indented that, had it been the only protection, the ship would have sunk immediately. As it was, with only the immense fracture of 86 feet in length closed, and the others only temporarily stopped, she has made her return trip successfully and safely. Similar plans have been previously adopted for the repair of ships' bottoms, but the magnitude of the caisson—104 feet long by 15 wide—is unprecedented, and complicated the work. The hose packing, which conduced, perhaps, more than anything else to the success of the undertaking, is, it is believed, a novelty, and was devised by the Messrs. Renwick, who projected the plans for the repair of the ship, and directed the whole work.

GREECE, a limited monarchy in the S. E. of Europe, having an area of 18,244 square miles, and a population of 1,067,216 inhabitants, or, adding the Ionian Islands, which the British Government have given the opportunity to unite with the Greek kingdom, 19,350 square miles, and 1,318,699 inhabitants. Greece is now under a provisional government, of which Demetri Bulgaris is president, with two vice-presidents and a council of seven.

During the past year Greece has undergone a revolution, which has resulted in the overthrow and banishment of the late King Otho I. A brief explanation of the causes which led to this revolution may properly preface an account of it. Greece, which since the 15th century had been under Turkish domination, worn out with the constantly increasing oppression of the Ottoman power, revolted in 1821, and a war of seven years, marked by terrible atrocities on the part of the Turks, followed. In October, 1827, the Greeks, aided by a combin-

ed English, French, and Russian fleet, gained the battle of Navarino, which broke the Turkish power, and led to the acknowledgment of their independence, under the protection of the three powers who had contributed to their liberation. At first the government was nominally a republic, and Count Capodistrias, a Greek statesman, long in the service of Russia, was president; but the three protecting powers decided that they must have a monarchical government, and on the assassination of Count Capodistrias in October, 1831, these powers, after some deliberation, selected, as their king, Otho, second son of the king of Bavaria, born in 1815. He arrived at Nauplia in 1833, and at first assumed the government under a regency of three, selected by his father, all Bavarians, and two of them utterly ignorant of the country, and even of its language. In 1836 the king married Amelia, daughter of the grand duke of Oldenburg, and took the management of affairs himself, or rather committed them to the queen, as the abler member of the royal firm. Otho was not by nature cruel or tyrannical, but he was weak, indolent, and selfish, and wedded wholly to Bavarian ideas. His queen was far more capable, but imperious, selfish, and bent upon the gratification of her own will, and scrupled at no tyranny which should extract from the Greeks the money necessary to carry out her plans, while she was unwilling to do anything to promote the interests of the people. The result has been that oppression followed oppression till all motive for enterprise or improvement was lost, and the country sunk into a state of apathy, from which it was only roused by occasional spasmodic efforts to throw off the hated Bavarian yoke. The municipal governments of the villages, a relic of ancient Greece, which had been preserved through three and a half centuries of Turkish domination, were discontinued; the monasteries were abolished, but their lands and funds, instead of being applied to the purposes of education, were taken as the property of the crown, which further became the proprietor of about two thirds of the cultivated, and four fifths of the uncultivated lands of the kingdom. On these lands the tenants were required to pay 15 per cent. of the gross product of the land in kind, as rent for its usufruct, and in addition a land tax of from 3 to 10 per cent. also in kind; and these taxes and rents were exacted in the most aggravating and wasteful manner. The whole taxes and rents were farmed, and the cultivator could neither reap nor thresh his crop without the permission of the farmer, who often withheld the permission, till the crop was nearly worthless, in order to extract more from the hapless cultivator. The crop when gathered must be transported from five to twelve miles over the most abominable roads, to be threshed, that there might be no withholding of the farmer's portion, and when brought to the threshing floor, it was often many weeks before permission to thresh

it was accorded, and during this time the cultivator must remain by to watch it. On an average three months were lost to each cultivator in this way, and all inducement to increase the quantity of the crops was taken away. Except in the immediate vicinity of Athens there were neither roads nor bridges, although the country is preëminently one of swift flowing streams, high hills, and deep ravines. There were not 120 miles of tolerable roads, and but half a dozen bridges in the kingdom. Manufactures were discouraged by heavy imposts, till there remained only some gold and silver embroidery work at Athens, some iron ware at Tripolitza, a little silk gauze at Calamata and Mistra, and some woollen fabrics on a very limited scale manufactured at Lebadea. While five or six short and inexpensive railroads, connecting important points, would have soon quadrupled the production of Greece, the Government not only would not interest itself in their construction, but opposed and forbade any application of private capital for the purpose. Centralization was the policy of the court. Athens, as the royal residence, must be aggrandized, but all the rest of Greece might go to waste.

At the close of her struggle for independence Greece had a constitution of a somewhat liberal character, but this the regency and the king himself, when he came into power, utterly ignored, and the despotism of the Government grew more intolerable with each year, till in 1843 the people rose in revolution, with the rallying cry of *Zῆτρο το Συταγμα* ("Long Live the Constitution"). Gen. Kalergy was in command, and the army on which the king relied to defend him from the people, fraternized with them. After attempting in vain to escape the alternative presented him of resigning, or dismissing his Bavarians, appointing a new ministry, calling a national assembly, and accepting a constitution drawn up by them, he finally acceded to the latter, signed the ordinances presented to him, and when the national assembly had drawn up a constitution, he accepted it. The constitution thus prepared was defective in many particulars, but Otho and his queen did not observe its provisions, and hence any good there was in it failed to enure to the benefit of the people. The two chambers, instead of being elected by fair popular vote, were packed with adherents to the crown; the ballot was tampered with, and if by any accident a Greek patriot was elected, spurious ballots sufficient to defeat his election were substituted for the true ones. The ministry were notoriously takers of bribes, falsifiers of ballots, and tools of the despotism, and were openly accused of every species of baseness.

For ten years the people endured these increasing evils, which were aggravated by the growing rapacity of the queen. The revenues had been increasing; but this fact was carefully concealed from the people, and the payment of 900,000 drachmas annually, guaranteed

by the constitution toward the liquidation of the debt of \$12,000,000, contracted by Greece at her independence, with the endorsement of the three powers, was withheld by the king, and used for the purposes of the court, as a considerable portion of the principal of the loan had been.

In 1854 another revolution became imminent, and was only avoided by the adroitness of the Government (an adroitness never manifested on any other occasion), in bringing forward the project of a Byzantine empire. The questions which led to the Crimean war were in agitation, and the queen and ministers prompted the people to side with Russia, and to make the effort to alienate from Turkey the provinces of Epirus and Theesaly, and the Grecian islands, to form a new Greek domain. Infatuated with this idea, Otho for once became popular, and his already despotic powers were enlarged, while the wealthier Greeks subscribed large sums of money, which were greedily absorbed by the court to promote so desirable an end. In less than a year they woke from their dream to find they had been duped. The allied powers threatened them, and occupied their capital with an armed force; Turkey was exasperated, and their money had been spent on its own projects by the Government which had become more absolute than before. The people became satisfied that their Bavarian rulers cared nothing for them, but only for their money, and that there could be no improvement or progress till they were rid of them; but who could be substituted for them, was the question, and a very difficult one it was to solve.

In 1856 the three protecting powers appointed a commission to investigate the administrative and financial state of Greece. This commission, consisting of an English, French, and Russian member, spent more than two years in their inquiries, and published their report in 1860. According to this report the interest of the debt already referred to had not been paid since 1843, and amounted in 1859 to \$11,228,476, and at the present time would amount to about \$16,400,000. There was besides this a home debt of about \$12,500,000. The Government, the commission reported, had used without accounting for them the communal funds, had encroached systematically upon the public domain, had published no account of the finances, and though the revenues had increased, had carefully concealed that fact from the people, whom they had constantly plundered.

This report did not lessen the utter distrust and contempt of their king and queen which was possessing the minds of the Greeks; and it required but a slight incident to develop it in another revolution. On the 28th of May a conspiracy, supposed to be of great extent, was discovered in Athens, but it turned out to be a false alarm, and the king and queen soon subsided into their old condition of apathy. Otho went in the summer as usual to the German spa, and left the queen as regent. On the 15th of September, at 9 o'clock in the evening, as

she was returning from her model farm at Parnes, seven miles from Athens, a man stepped forward and fired a pistol at her. He missed his aim, and was arrested on the spot; he proved to be a young man of high family, a nephew of Mavrocordatos, and a son of parents who had been illustrious both for patriotism and intellectual ability. His name was Aristides Dosias. He freely admitted the act, and justified it on the ground of patriotic devotion to his country's welfare, which the queen had imperilled. His trial caused great excitement throughout Greece, and when found guilty, and condemned to death, the queen commuted his sentence to imprisonment for life. A few months later, a conspiracy for the assassination of Otho was discovered just in time to save his life. Warned by these and other incidents, the king at first seemed disposed to satisfy his subjects, and about the 1st of January, 1862, summoned Canaris, a brave and patriotic Ipsariot, to form a ministry. The old patriot addressed to the king a memorial, in which he stated the conditions under which he would be willing to serve in this capacity; these were: 1st, the dissolution of the chambers, which had been fraudulently elected, and the guaranty of a perfectly free election of their successors; 2d, the formation of a national guard, and, 3d, the relieving of the press from the censorship which had paralyzed it. The king was not at all pleased with this programme, and fearing lest Canaris should present a list of patriotic ministers, he dismissed him, and the same day the profligate and corrupt tools who served the king as ministers, announced to the chambers that it had never been intended that they should be removed. "So then Canaris was only called to the court to be made a buffoon?" was the stinging reply. The nation was exasperated, but not quite ripe for revolution. In the reaction from his spasm of penitence the king showed himself more of a despot than before. More than a thousand patriots were arrested and thrown into prison on the charge of having intended to conspire against the Government, and maddened by this tyranny, a number of officers in the mountain fortress of Palamede, overlooking the city of Nauplia, on the 12th of February, 1862, proclaimed a revolt. Among them were Col. Coroneos, who had been an officer in the English, French, and German service; Col. Zimbrakaki, who had distinguished himself in the French service in the Crimea; Commander Artemis, and Lieut. Grivas, both officers greatly beloved by the sol-

diers. The Nauplians and the citizens of the vicinity responded to the call, but the country generally was not ready, and after a siege of two months, in which some sharp actions were fought, and Coroneos wounded, and made prisoner, they finally capitulated on the 20th of April, an amnesty being granted to all except 19, who were required to leave the country. This amnesty was disregarded, and the officers and men who had capitulated were thrown into prison. Meantime another insurrection had broken out on the island of Syra, at the head of which were Leotzakos, a distinguished Greek officer, and Moraitines, son of an eminent judge. In a naval battle at Thermia between the insurgents and Otho's forces, these two brave leaders were killed and their forces defeated; but the Syrans would not submit, nor yield allegiance to the king. As the summer approached, the evidences of the discontent of the people became more alarming, and the Government resorted to more high handed measures to repress insurrection. The criminals were set free from the prisons to plunder the patriots, and their places filled by the best citizens of Greece. The press was prohibited from uttering the sentiments of the people, and the chambers, though filled by those who had been the friends of Government, were awed into silence by force. The people in June and July were shouting for Amadeus (second son of Victor Emanuel) under the walls of the palace. At length, the king on the 28d of September prorogued the chambers, which he could not wholly silence, to November; and the people felt that the time for action had come. On the 20th of October, the king finding his power and influence gone, abdicated in favor of his brother. A provisional government was formed at Patras, under the presidency of Demetri Bulgaris, and proclaimed the deposition of the Bavarian dynasty; and on the 24th of October, almost unattended, and in fear and trembling, the royal pair went on board ship at Nauplia, and left forever that Greece which for thirty years they had so abused and oppressed.

The provisional government ordered an election for a king, and Prince Alfred of England was chosen by an almost unanimous vote; but as the agreement between the three protecting powers forbade the elevation of a prince of either house to the Greek throne, it has since been offered to the ex-king of Portugal, and to the duke of Saxe Coburg and Gotha, but was declined by both.

## H

**HABEAS CORPUS.** The arrest and confinement of persons by orders from the Secretary of War, Edwin M. Stanton, continued nearly to the close of the year 1862 in the same manner as in 1861. (*See ANNUAL CYCLOPÆ-*

*DIA*, 1861: **HABEAS CORPUS.**) It was declared by those citizens who were opposed to these proceedings, that they were in violation of the following amendments to the Constitution of the United States:

ART. 4. The right of the people to be secured in their persons, houses, papers and effects against unreasonable searches and seizures shall not be violated: and no warrants shall issue but upon probable cause, supported by oath or affirmation, and particularly describing the place to be searched, and the persons or things to be seized.

ART. 5. No person shall be held to answer for a capital or otherwise infamous crime, unless on a presentment or indictment of a grand jury, except in cases arising in the land or naval forces, or in the militia when in actual service, in time of war or public danger; nor shall any person be subject, for the same offence, to be twice put in jeopardy of life or limb: nor be compelled in any criminal case to be a witness against himself; nor be deprived of life, liberty, or property without due process of law; nor shall private property be taken for public use without just compensation.

ART. 6. In all criminal prosecutions the accused shall enjoy the right to a speedy and public trial, by an impartial jury of the State and district wherein the crime shall have been committed, which district shall have been previously ascertained by law, and to be informed of the nature and cause of the accusation; to be confronted with the witnesses against him; to have compulsory process for obtaining witnesses in his favor; and to have the assistance of counsel for his defence.

A large number of the arrests of the previous year had been made by orders issued from the Secretary of State, but the matter was early in the year transferred to the War Department. On the 8d of December, 1861, the commanding officer at Fort Lafayette came to the prisoners' quarters and read a document of which the following is a copy:

*To the Political Prisoners in Fort Lafayette:*

I am instructed by the Secretary of State to inform you that the Department of State of the United States will not recognize any one as an attorney for political prisoners, and will look with distrust upon all applications for release through such channels; and that such applications will be regarded as additional reasons for declining to release the prisoners.

And further, that if such prisoners wish to make any communication to Government, they are at liberty to make it directly to the State Department.

SETH C. HAWLEY.

The prisoners, it would seem, were by the activity of their friends, becoming troublesome to the Government, and this notice had the effect to suspend their activity.

The following order is the only instance during the year in which an official statement was made of the arrest of any citizen. In this instance, the party arrested was soon after set at liberty.

WAR DEPARTMENT, WASHINGTON, Feb. 10, 1863.

Ordered that a person calling himself Dr. Ives, a native of a rebel State, whose brother, lately in the military service of the United States, is now an officer in the rebel army, and who pretends to be a special representative of the New York "Herald" for Washington, be arrested and held in close custody at Fort McHenry as a spy, and for violating the rules and regulations of this Department in this:

That on Saturday, the 8th of February, 1862, against the public and well known regulations for the safe transaction of Congressional business, he intruded himself into the War Department and into the chambers where the Secretary and his assistants were transacting business with members of Congress, for the purpose of spying and obtaining war news and intelligence in regard to Cabinet consultations, telegraphs,

&c., for publication, which he knew was not authorized to be published; and having so intended, he conducted himself insolently, making threats to the Assistant Secretary, Peter H. Watson, of the hostility of the New York "Herald" against the administration of the War Department, unless he was afforded special privileges and furnished intelligence by the Department in respect to Cabinet consultations, telegrams, official communications, and all news the moment it was received by the Department, in advance of all other papers.

The War Department is the place where the President, the Commander-in-Chief of the Army and Navy and his subordinates, the Secretary of War, and other public officers, are earnestly engaged in the business of overcoming treason and rebellion against the Government of the United States. It is not a place where spies or traitors, or any person, but for public purposes, can be suffered to enter or harbor.

Newspapers are valuable organs of public intelligence and instruction, and every proper facility will be afforded to all loyal persons to procure, on equal terms, information of such public facts as may be properly made known in time of rebellion. But no matter how useful or powerful the press may be, like everything else, it is subordinate to the national safety. The fate of an army or the destiny of the nation may be imperilled by a spy in the garb of a newspaper agent. The nation is in conflict with treason and rebellion—may be threatened by foreign foes.

The lives and fortunes of twenty millions of people, and the peace and happiness of their posterity, in the loyal States—the fate of public liberty and republican government forever—are staked upon the instant issue. The duties of the President and his Secretary, of every officer of the Government, especially in the War Department and military service, are at this moment urgent and solemn—the most urgent and solemn that ever fell upon men. No news gatherer, nor any other person, for sordid or treasonable purposes, can be suffered to intrude upon them at such a time to procure news by threats, or spy out official acts which the safety of the nation requires not to be disclosed.

For these reasons the aforesaid Ives has been arrested and imprisoned, and all persons so offending will be dealt with in like manner.

(Signed) EDWIN M. STANTON,  
Secretary of War.

On the 14th of February, an order was issued transferring the matter of all arrests to the War Department, offering to release political prisoners on parole, and directing that future arrests shall be made by military authority. The order was as follows:

*Executive Orders in Relation to State Prisoners. No. 1.*

WAR DEPARTMENT, WASHINGTON, Feb. 14.

The breaking out of a formidable insurrection, based on a conflict of political ideas, being an event without precedent in the United States, was necessarily attended by great confusion and perplexity of the public mind. Disloyalty, before unsuspected, suddenly became bold, and treason astonished the world by bringing at once into the field military forces superior in numbers to the standing army of the United States.

Every department of the Government was paralyzed by treason. Defection appeared in the Senate, in the House of Representatives, in the Cabinet, in the Federal Courts; Ministers and Consuls returned from foreign countries to enter the insurrectionary councils, or land or naval forces: commanding and other officers of the army and in the navy betrayed the councils or deserted their posts for commands in the insurgent forces. Treason was flagrant in the revenue and in the post office service, as well as in the territorial governments and in the Indian reserves.

Not only Governors, Judges, Legislators, and ministerial officers in the States, but even whole States, rushed, one after another, with apparent unanimity,

into rebellion. The capital was besieged and its connection with all the States cut off.

Even in the portions of the country which were most loyal political combinations and secret societies were formed furthering the work of disunion, while, from motives of disloyalty or cupidity, or from excited passions or perverted sympathies, individuals were found furnishing men, money, and materials of war and supplies to the insurgents' military and naval forces. Armies, ships, fortifications, navy yards, arsenals, military posts and garrisons, one after another, were betrayed or abandoned to the insurgents.

Congress had not anticipated and so had not provided for the emergency. The municipal authorities were powerless and inactive. The judicial machinery seemed as if it had been designed not to sustain the Government, but to embarrass and betray it.

Foreign intervention, openly invited and industriously instigated by the abettors of the insurrection, became imminent, and has only been prevented by the practice of strict and impartial justice with the most perfect moderation in our intercourse with nations.

The public mind was alarmed and apprehensive, though fortunately not distracted or disheartened. It seemed to be doubtful whether the Federal Government, which one year before had been thought a model worthy of universal acceptance, had indeed the ability to defend and maintain itself.

Some reverses, which perhaps were unavoidable, suffered by newly levied and inefficient forces, discouraged the loyal, and gave new hopes to the insurgents. Voluntary enlistments seemed about to cease, and desertions commenced. Parties speculated upon the question whether conscription had not become necessary to fill up the armies of the United States.

In this emergency the President felt it his duty to employ with energy the extraordinary powers which the Constitution confides to him in cases of insurrection. He called into the field such military and naval forces, unauthorized by the existing laws, as seemed necessary. He directed measures to prevent the use of the post office for treasonable correspondence. He subjected passengers to and from foreign countries to new passport regulations, and he instituted a blockade, suspended the writ of habeas corpus in various places, and caused persons who were represented to him as being or about to engage in disloyal and treasonable practices to be arrested by special civil as well as military agencies, and detained in military custody, when necessary, to prevent them and deter others from such practices. Examinations of such cases were instituted, and some of the persons so arrested have been discharged from time to time under circumstances or upon conditions compatible, as was thought, with the public safety.

Meantime a favorable change of public opinion has occurred. The line between loyalty and disloyalty is plainly defined; the whole structure of the Government is firm and stable; apprehension of public danger and facilities for treasonable practices have diminished with the passions which prompted heedless persons to adopt them. The insurrection is believed to have culminated and to be declining.

The President, in view of these facts, and anxious to favor a return to the normal course of the Administration, as far as regard for the public welfare will allow, directs that all political prisoners or State prisoners now held in military custody be released on their subscribing to a parole engaging them to render no aid or comfort to the enemies in hostility to the United States.

The Secretary of War will, however, in his discretion, except from the effect of this order any persons detained as spies in the service of the insurgents, or others whose release at the present moment may be deemed incompatible with the public safety.

To all persons who shall be so released, and who shall keep their parole, the President grants an amnesty for any past offences of treason or disloyalty which they may have committed.

Extraordinary arrests will hereafter be made under the direction of the military authorities alone.

By order of the President:

EDWIN M. STANTON, Secretary of War.

It is not known to what extent prisoners were set at liberty under this order; but on the 27th of the same month the following additional order was issued:

WAR DEPARTMENT, WASHINGTON, Feb. 27, 1862.

It is ordered, First, That a special commission of two persons, one of military rank, and the other in civil life, be appointed to examine the cases of the State prisoners remaining in the military custody of the United States, and to determine whether, in view of the public safety and the existing rebellion, they should be discharged or remain in military custody, or be remitted to the civil tribunal for trial.

Second, That Major-General John A. Dix, commanding in Baltimore, and the Hon. Edward Pierpont, of New York, be, and they are hereby appointed commissioners for the purposes above mentioned; and they are authorized to examine, hear and determine the cases aforesaid, *ex parte*, and in a summary manner, at such times and places as in their discretion they may appoint, and make full report to the War Department.

By order of the President:

EDWIN M. STANTON, Secretary of War.

This commission visited the Old Capitol prison at Washington and Fort McHenry at Baltimore, Fort Lafayette at New York, and Fort Warren at Boston.

Previous to the appointment of the commission many prisoners had been offered their liberty on condition of subscribing to the following parole:

I hereby give my parole of honor not to render any aid or comfort to the enemy in hostility to the United States.

Many expressed their willingness to sign, provided they could do it without the act being considered as a condition of their release. To all applications for a legal examination of the case, or a discharge from confinement on such terms as would prove their innocence of all complicity with treason, no answer was returned.

The proceedings in one or two cases of examination before the commission have been made public. One is that of David C. Wattles, who was arrested at North Branch, Michigan, on Nov. 23, 1861, and imprisoned at Fort Lafayette. The examination is thus reported.

Mr. Wattles, with nine others, were first called up, and asked the following questions:

"When were you arrested?" "Where were you arrested?" "What is your age?" "What were you arrested for?" These questions were each answered by Mr. Wattles, except the last one, which he informed them was one he was as anxious to have answered as they could be. After asking him if he sympathized with the rebels, and a few similar questions, the Commission expressed themselves satisfied. Their secretary, however, was not so clear, and interposed to ask him if there was not a secession flag raised at North Branch, and if he did not participate in raising it? To this Mr. Wattles responded, that he heard that Isaiah Butler had an old shirt which he had used in straining blackberry juice for wine making, which he on an occasion exhibited as a secession flag, and that the story of this flag had travelled throughout the country, receiving additions as it went.

This closed the examination, and Mr. Wattles was—

removed to the "house of detention," where he was retained until the day following, when he was again brought before the Commission and informed that he could have his liberty by signing the parole. He again expressed his willingness to sign after he could have an examination. Gen. Dix replied: "This is an examination that you have had." Mr. Wattles again demurred. He wished to return to his home free from all charges and suspicions; but as there was no other alternative, he concluded to sign.

The case of the Messrs. Flanders, of Franklin county, New York, contains some facts which took place at an earlier date, which have been thus reported:

Not long after the transfer of the prisoners from Fort Lafayette to Fort Warren, notice was given that on a certain day Mr. Seth C. Hawley would visit the fort for the purpose of ascertaining who among the persons confined there were willing to take the "oath of allegiance," as it was termed, as a condition, not of release, but of having their cases examined into and reported upon. This oath reads as follows:

"I do solemnly swear that I will support, protect, and defend the Constitution and Government of the United States against all enemies, whether domestic or foreign, and that I will bear true faith, allegiance, and loyalty to the same, any ordinance, resolution or law of any State, Convention, or Legislature to the contrary notwithstanding; and further, that I do this with a full determination, pledge, and purpose, without any mental reservation or evasion whatsoever; and further, that I will well and faithfully perform all the duties which may be required of me by law. So help me God."

The Messrs. Flanders united in a reply to this proposition, declining to take the prescribed oath for the following reasons:

"We have been guilty of no offence against the laws of our country, but have simply exercised our constitutional rights as free citizens, in the open and manly expression of our opinions upon public affairs. We have been placed here without legal charges, or, indeed, any charges whatsoever, being made against us, and upon no legal process, but upon an arbitrary and illegal order of the Hon. William H. Seward, Secretary of State of the United States. Every moment of our detention here is a denial of our most sacred rights. We are entitled to, and hereby demand an unconditional discharge; and while we could cheerfully take the oath prescribed by the Constitution of the United States, because we are, always have been, and ever intend to be loyal to that instrument (though at the same time protesting against the right of the Government to impose even such oath upon us as the condition of our discharge), we cannot consent to take the oath now required of us, because we hold no office of any kind under the Government of the United States, and it is an oath unknown to, and unauthorized by, the Constitution, and commits us to the support of the Government, though it may be acting in direct conflict with the Constitution, and deprives us of the right of freely discussing, and by peaceful and constitutional methods opposing its measures—a right which is sacred to freedom, and which no American citizen should voluntarily surrender. That such is the interpretation put upon this oath by the Government, and such its intended effect, is plainly demonstrated by the fact that it is dictated to us as a condition of our release from an imprisonment inflicted upon us for no other cause than that we have exercised the above specified constitutional rights."

After the Secretary of War, Mr. Simon Cameron, resigned in January, he was appointed minister to Russia. When he was nearly ready to embark for that country, on April 15th, a writ from the Supreme Court of Pennsylvania was served upon him at the suit of Mr. Pierce

Butler for trespass, assault and battery, and false imprisonment on the 19th of August previous. At that time Mr. Butler was suspected of a correspondence with the Confederate States unfavorable to the cause of the Union, and during a moment of public excitement was arrested by order of Mr. Cameron, without process of law, and without any assigned cause, his trunks, drawers, wardrobe, and entire apartments searched, and private papers taken possession of by the United States marshal and four assistants. His office was also examined, his books and papers taken, and in one hour from the arrest he was on his way to New York, with the marshal and his assistants, all armed with revolvers, who conducted him that evening to Fort Lafayette. A subsequent application on the part of Mr. Butler's friends to the Secretary of War, to ascertain the reason of his action, though in a measure answered, induced no satisfactory response.

He asserted that nothing was found among his papers to call in question his loyalty to the Government, and in obtaining the writ he refrained from arrest and the demand for security from Mr. Cameron, as his wish was merely to test the constitutionality of his imprisonment. He was liberated five weeks from his imprisonment, without a reason being given for his discharge any more than for his arrest.

The following correspondence took place in consequence of this arrest:

PHILADELPHIA, April 16, 1862.

SIR: By the directions of Gen. Simon Cameron, I send you a summons issued by the Supreme Court of this State, at the suit of Pierce Butler *versus* Simon Cameron, July 1, 1862—November 17. The writ is returnable the first Monday of May, 1862, and is for trespass *vi et armis*, assault and battery, and false imprisonment.

The cause of action is no doubt founded upon the supposed misconduct of Gen. Cameron in causing the arrest of the plaintiff, Mr. Pierce Butler, and placing him in Fort Warren, or some other public fortification, without authority of law, while he, Gen. Cameron, was Secretary of War. As I am instructed, the act was not the act of Gen. Cameron, and was done by those who commanded it to be done for just reasons and for the public good.

You will please communicate the fact of the suit to the President and such other official persons as should properly be advised of it, and have such action taken as shall relieve the defendant, Simon Cameron, from the burden, cost, and responsibility of defending this suit.

By direction of Gen. Cameron, I have, as his private counsel, ordered my appearance for him, while I also invite and request the intervention of the proper authorities in his behalf and for his protection. I am, sir, truly, &c. BENJAMIN H. BREWSTER.

Hon. WILLIAM H. SEWARD, Secretary of State.

DEPARTMENT OF STATE,  
WASHINGTON, April 18, 1862. }

SIR: I have received your letter of yesterday, stating that, by directions of Mr. Simon Cameron, you transmit to me a summons issued out of the Supreme Court of the State of Pennsylvania, at the suit of Pierce Butler against Mr. Cameron, for trespass *vi et armis*, assault and battery, and false imprisonment, in causing the arrest of the plaintiff without authority of law.

This communication has been submitted to the President; and I am directed by him to say, in reply, that

he avows the proceeding of Mr. Cameron referred to as one taken by him when Secretary of War, under the President's directions, and deemed necessary for the prompt suppression of the existing insurrection.

The President will at once communicate this correspondence to the Attorney General of the United States, and also to Congress. I am, sir, your obedient servant,  
WILLIAM H. SEWARD.

BENJAMIN E. BREWSTER, Esq., Philadelphia.

A case bearing upon this point occurred a few years since in New York. It was that of Commander Hollins, against whom an action of trespass was brought in the New York Common Pleas on behalf of owners of property destroyed by him in his bombardment of Greytown, Nicaragua. The cause was removed into the United States Circuit Court, and argued before Mr. Justice Nelson on the point raised, that Hollins, as commander of the sloop of war Cyane, was acting under orders from his superior officer, the President of the United States, and therefore was not personally liable to the plaintiff. To this it was replied that the President had no power to declare war, and that therefore the act both of the President and Hollins was without show of authority, and both were guilty of injuring the plaintiff. The Court, after having had the matter under advisement for some time, ruled that the decision of the Executive was final, and justified Hollins in the execution of his orders.

Arrests still continued to be made, but under the form of military orders, of which the following is an instance: An order was issued by Maj.-Gen. Dix to a deputy provost marshal to arrest Richard Carmichael, judge of Talbot county court, Maryland, and Isaac Powell, the prosecuting attorney, on a charge of treason. Gen. Dix was at the time in military command at Baltimore. The arrest was made by the deputy marshal, McPhail, assisted by several officers from Baltimore. A military company was also detailed in view of threatened resistance, but their services were not used. The manner in which this arrest was made is thus related :

The marshal and his men went into the court house, where the Judge was presiding upon the bench, and ascending the place, told the Judge that he must consider himself under arrest and a prisoner. The Judge seemed astonished, and demanded the authority for such a proceeding, and was answered, by the authority of the United States Government. The Judge's reply indicated that he did not regard that authority under the circumstances of the case. Here a call was made for the sheriff of the county ; and the crier of the court, seated near the window, was adding to the excitement, but was soon silenced with the threat that if he said another word he would be knocked down. Officer Bishop, receiving an order to take the Judge in custody, took hold of him, when the Judge kicked him. Bishop then drew a revolver, and with it struck the Judge upon the head several times. Others arrested Mr. Powell and two citizens named William Nabb and Elixir Pascault. The proceeding was prompt, decisive, and done in less time than is required to write an account of it. But the court room presented a most singular scene, all present being greatly excited. The members of the jury, who were sitting in the box, asked for directions as to what they should do, but getting no answer, soon left the building. The arrests having been made, Judge Carmichael was attended by

a physician of the town, who dressed his wounds. The military soon made their appearance, and the whole party, after a short delay, marched to the landing, where a steamer was in waiting, and started for Baltimore. The boat stopped at Fort McHenry, and placed the prisoners in charge of Col. Morris, commanding the post.

Another instance is thus described :

Mr. William H. Offutt, a venerable citizen of Montgomery county, Md., was arrested at his home on May 23d, by order of Gen. Wadsworth, the military governor of the District of Columbia, and lodged in the Old Capitol as a "prisoner of State."

It seems that this gentleman had by a due process of law recovered a fugitive slave belonging to him under the laws of Maryland. On the ground that this slave had received a "military protection," Gen. Wadsworth sent a file of soldiers into Montgomery county, twenty-three miles from Washington, to demand the restitution of the person returned by the civil authority charged with the execution of the fugitive slave law. As the slave could not be produced, in consequence of his removal to another part of Maryland, the owner, Mr. Offutt, was arrested in his stead and brought to Washington, where, as before said, he was imprisoned at the "Old Capitol building."

Mr. Blair, the Postmaster-General, becoming aware of the facts, and being apprised of the estimable character of Mr. Offutt, as also of his approved loyalty, immediately procured his release from the custody in which he was held.

On the 24th of September, President Lincoln issued the following proclamation :

*Whereas* it has become necessary to call into service not only volunteers, but also portions of the militia of the States by draft, in order to suppress the insurrection existing in the United States, and disloyal persons are not adequately restrained by the ordinary processes of law from hindering this measure, and from giving aid and comfort in various ways to the insurrection,

Now, therefore, be it ordered—

*First.* That during the existing insurrection, and as a necessary measure for suppressing the same, all rebels and insurgents, their aiders and abettors, within the United States, and all persons discouraging volunteer enlistments, resisting military drafts, or guilty of any disloyal practice, affording aid and comfort to the rebels against the authority of the United States, shall be subject to martial law, and liable to trial and punishment by courts martial or military commission.

*Second.* That the writ of *habeas corpus* is suspended in respect to all persons arrested, or who are now, or hereafter during the rebellion shall be, imprisoned in any fort, camp, arsenal, military prison, or other place of confinement by any military authority, or by the sentence of any court martial or military commission.

In witness whereof, I have hereunto set my hand, and caused the seal of the United States to be affixed.

Done at the city of Washington, this twenty-fourth day of September, in the year of our

[L. S.] Lord one thousand eight hundred and sixty-two, and of the independence of the United States the eighty-seventh.

ABRAHAM LINCOLN.

By the President :

WILLIAM H. SEWARD, Secretary of State.

This was followed soon after by an order from the Secretary of War, appointing a provost marshal general of the War Department, with headquarters in Washington ; and one or more special provost marshals as necessity might require in each State, who were required to report to and receive instructions and orders from the provost marshal general. The chief

design of the order was stated to be the arrest of deserters. (*See*, for the order, ARMY OF THE UNITED STATES.)

The action of the civil courts during this state of affairs is illustrated by a few examples.

On the 18th of September, Isaac C. Thomas, a citizen of Bucks county, Penn., was arrested on a charge of discouraging enlistments. On the 20th John H. Cook, of Philadelphia, was arrested by authority of the following order, which is an example of those used in these cases:

WAR DEPARTMENT, WASHINGTON CITY, }  
Sept. 19, 1862. }

To BENJ. FRANKLIN, Esq., Chief of Police, Philadelphia:

Yours of the 17th instant and enclosed is received. You are hereby authorized to arrest John Cook upon the charge specified in the affidavits you sent. You will imprison him at the usual place of keeping in custody persons arrested for political offences, and report.

By order of the Secretary of War,  
D. C. TURNER, Judge Advocate.

In the case of Thomas an application was made to Judge Cadwalader, of the United States District Court for the State of Pennsylvania, who on the 24th issued a writ of *habeas corpus*, returnable on the 26th. Similar action took place in the case of Cook, and both the parties accused were admitted to bail. The report of the proceedings of the court is as follows:

At the hearing, Mr. Knox, who, with Messrs. Coffee and Ashton, represented the marshal, filed a petition with a motion to quash the writ, citing the President's proclamation suspending the writ of *habeas corpus*. Mr. Knox contended that, under this proclamation, the judge could not interfere with the arrest.

Judge Cadwalader desired to hear an argument on the following points:

*First.* Whether a person who is not in the military service of the Government, and is not in a place where hostilities are actually pending or threatened, and is not at a place in military occupation, is liable to military arrest in a district in which the courts of ordinary civil and criminal jurisdiction are open for the regular administration of justice.

*Second.* Whether the third section of the act of 6th August, 1861, legalizing and making valid all the acts, proclamations, and orders of the President after 4th March, 1861, applies to his acts, proclamations, and orders of a similar character made after the enactment of that law; and if not, whether any other act of Congress has expressly or impliedly authorized the proclamation in question.

*Third.* Whether the President has the authority without or independent of any statutory authorization.

Mr. Knox contended that the burden of showing that the act of the President was not authorized, was with the other side. It was not incumbent upon him to show that the President had authority, as the judge must presume, until the contrary, that the act was lawful. He further contended that, if there was to be any postponement of the case, the accused should be remanded to the custody of the marshal.

Mr. Brewster, who, with Mr. Brooke, represented Mr. Thomas, stated that his client was amongst the most loyal of the citizens. He desired time to prepare an argument on the questions presented by the court.

Judge Cadwalader fixed Monday at noon for the hearing, and admitted the accused to bail to appear at that time.

On Monday, at the hour appointed, the cases of Isaac C. Thomas and John H. Cook, charged with disloyal practices, were called up, when the following proceedings took place:

Mr. Knox, representing the United States marshal, asked and obtained leave, in the case of Mr. Thomas, to withdraw the application, made a few days ago, to quash the writ of *habeas corpus*. He then presented the following return:

"To the Hon. John Cadwalader, Judge of the District Court of the United States for the Eastern District of Pennsylvania:

"Wm. Millward, the defendant in the within writ mentioned, for return thereto, respectfully states to your Honor that the said Isaac C. Thomas was arrested by him before the issuing of his writ, in pursuance of an order to that effect made by the Secretary of War, through L. C. Turner, Judge Advocate; and that immediately upon the issuing and service of this writ, the said Isaac C. Thomas was removed from the custody of the defendant by the order of your Honor, he having entered into recognizance, with sureties, for his appearance, and to abide the order of the Court in his behalf; and that he is not now, nor has he been since the time aforesaid, in the custody of the defendant; and the defendant further states that he has recently received directions from the War Department to discharge the said Isaac C. Thomas from the arrest aforesaid, and that he does not claim the custody of the relator.  
WM. MILLWARD.

"PHILADELPHIA, Sept. 30, 1862."

Mr. Knox also presented a return in a similar form in the case of Mr. Cook. He then said: In presenting these returns I desire to say that I knew nothing of these arrests until some time after they were made, and after the writs of *habeas corpus* had been issued by your Honor. Upon inquiry I learn that affidavits had been made making certain charges against these parties.

The Judge: Is it regular that, after these returns, I should hear any argument?

Mr. Knox: I do not propose to present an argument at all, but simply to make a statement. Affidavits had been made making charges against these parties. Those affidavits were forwarded to the War Department. That department, through the Judge Advocate at Washington, issued its orders for their arrest, one of the orders being directed to the chief of police of this city, the other to the marshal of the district. Upon receiving further information the proper authorities are satisfied that the public interests do not require that these persons should be further restrained of their liberty. Accordingly, the defendants have been instructed not to claim the further custody of the relators, without, however, conceding in any wise that, where a person is properly under military arrest, that arrest can be interfered with through the intervention of a writ of *habeas corpus*.

Mr. G. M. Wharton: We make no concession that there is any other "proper authority" than the judge of this court.

The Judge: These proceedings are ended by the returns. I regret that any subsequent remarks have been thought necessary. I have only to say to the respective petitioners that they are at liberty to depart and go whither they please.

About the same time a case occurred before the United States Court for the district including Vermont. Three persons had been arrested in Jericho, in that State, charged with disloyal practices, and imprisoned. A writ of *habeas corpus* was issued by Judge Smalley in behalf of one of these men. On the return day the marshal appeared before the court without the prisoner, and made return that the prisoner was detained under an order of the War De-



partment, dated August 8, suspending the writ of *habeas corpus* in such cases. The judge stated that "whether the President has the right to suspend the writ of *habeas corpus* without appealing to Congress was a controverted question. In his opinion the President has that power in cases of important military exigency; but be that as it may, that the Secretary of War and his subordinates have no power to suspend the writ; that the return of the marshal is not a compliance with the writ, and that unless within four hours the prisoner be produced in compliance with the order of court, he should issue a further order requiring the United States marshal and sheriff to show cause at the next term of the circuit court, on the 8d of October next, why an attachment should not issue against them for contempt of court."

The final decision of the court in this case was reported in substance as follows:

That the orders of the War Department under which the men against whom treason was alleged were arrested were in violation of the provisions of the Constitution of the United States, and were therefore illegal and void.

That if, under the provisions of the Constitution, the President of the United States had the power to suspend the writ of *habeas corpus*, he could not delegate that power to his subordinate officers.

That the Constitution made the President commander-in-chief of the military forces of the United States, and that this, with the provisions of the laws of 1795, which had been declared to be constitutional, conferred upon the President power to declare martial law, and martial law having been declared by the President's proclamation of the 24th of September, *ipso facto* the writ of *habeas corpus* was now suspended.

Therefore, if the said Field was now produced before the court, he could not be discharged, but would have to be remanded to the custody of the marshal.

On the 1st of September, however, when these proceedings were instituted against the marshal, the writ of *habeas corpus* was not lawfully suspended, and it was no justification to him that he acted under the orders of the War Department, those orders having been issued without the authority of law.

Marshal Baldwin was accordingly declared guilty of contempt of court, and fined one hundred dollars, which fine he paid.

In the State of New Hampshire, Nathaniel Batchelder, having been arrested on charges of disloyal speeches and practices by some of his fellow citizens, and imprisoned in Fort Constitution, on the 8th of September he applied to Chief Justice Bell, of the Supreme Court of the State, for the writ of *habeas corpus*. It was promptly granted, and served on the United States marshal, Mr. Ela. On the 19th Mr. Ela appeared before the court with counsel, Mr. Daniel Clark of the U. S. Senate, to make a return of the writ, and produced the following letter:

JUDGE ADVOCATE GENERAL'S OFFICE, Sept. 18, 1863.

Hon. JACOB H. ELA, U. S. Marshal, Rochester, N. H.

SIR: Your telegram to the Secretary of War, under date of the 10th instant, relative to the writ of *habeas corpus* issued in the case of Nathaniel Batchelder, arrested for disloyal practices, has been referred to this office for reply.

The Secretary of War directs me to inform you that, by an order issued under the authority of the Presi-

dent of the United States, a printed copy of which is enclosed, the writ of *habeas corpus* has been suspended in all cases of arrests for "disloyal practices," to which class of offences that of Nathaniel Batchelder manifestly belongs. The Secretary instructs me to say that to the writ of *habeas corpus* issued by Chief Justice Bell you should return these facts as your warrant for holding the prisoner in custody. Should any attempt be made, after the return, to release the prisoner by the civil authority, which is not anticipated, the Secretary directs that you appeal for support and protection, in the discharge of your duties, to the military force of the United States in your vicinity.

Very respectfully, your obedient servant,

J. HOLT, Judge Advocate General.

After an argument by counsel, the chief justice stated that it seemed to him to be inexpedient and useless to the prisoner to issue an order for an attachment which could not be enforced; that the Government of the United States had plainly expressed their determination to resist by force any attempt of the civil authority to deliver the prisoner, and that he received this not as a threat, but as the announcement of a settled resolution, which, with the vast armies under their control, they had the ability to execute against any power which the State could command for the enforcement of the law. He, therefore, declined to take further action in the case.

In Wisconsin a case occurred in which one Nicholas Kemp was arrested, and a writ of *habeas corpus* was granted, to which a return similar to those in the preceding cases was made. Issue was taken on the sufficiency of the return, and Chief Justice Dixon gave the unanimous opinion of the Supreme Court of the State, as follows:

This case pertains to the power of the President under the constitution and laws of the United States in time of civil war to suspend the writ of *habeas corpus*, declare martial law, and to arrest and cause to be punished by the sentence of a court martial or military commission, citizens charged with offences against the laws and regulations of war. It goes one step further; it involves the power of the President to declare and punish as offences those acts which are not made such by acts of Congress. These are emphatically questions of Federal cognizance, and which must, in the last resort, be determined by the Supreme Court of the United States, and I repeat my regret that it has become my duty to decide upon them at all.

I have, however, this encouragement, that for my errors there is a remedy, which though slow and sometimes embarrassed by State opposition, is nevertheless such as Congress has seen fit to provide. And this consideration, that our decision is preliminary and not final—that we merely prepare the way for the determination of the court which can alone settle the law, will relieve me from that extended discussion of the questions which their gravity and importance would otherwise seem to demand. The only motives to such a discussion are to show that I have not passed lightly over the grounds of my opinion—that I have not assumed to deny the legality of the acts of the President without a careful and deliberate examination of the whole subject, and these I must suffer to rest upon the assertion that I have given the questions the fullest consideration that my time and limited opportunities would permit. I am also led to this course because I cannot regard the principles involved as either new or doubtful.

They are, in my judgment, settled, so far as any matters of judicial inquiry can be said to be settled before a court not authorized finally to determine the

law for itself, by the uniform decisions of the courts and the concurrent opinions of eminent jurists and statesmen. I say matters of judicial inquiry, because I observe that a distinction has been attempted by the present learned Attorney General of the United States between *judicial* questions and *political* questions. I question the soundness of that distinction, and without particular criticism, feel myself obliged, for the present and until it has received the sanction of the Federal Supreme Court, to disregard it. I am acting in judicial capacity and must be governed by the established rules and maxims of the courts.

I may furthermore add that the principles involved have recently been the subjects of most profound and elaborate argument by several most able lawyers and judges. I refer to the opinion of Chief Justice Taney, in *ex parte* John Merryman, 9th American Law Register, 524; the article entitled "*Habeas Corpus* and Martial Law," "North American Review," Oct., 1861, pp. 471 to 519, supposed to be from the distinguished pen of Professor Parker of Cambridge; and the argument of Judge Curtis of Boston, entitled "Executive Power," pamphlet, Boston, Little, Brown & Co., 1862; and the opinion of Judge Hall, of the Northern District of New York, in the matter of Judson D. Benedict. I might under any circumstances, without repeating the arguments, content myself with a reference to these as a complete vindication of the conclusions at which I have arrived, and which I will proceed to state in as few words as possible.

And, first, I think the President has no power, in the sense of the ninth section of the first article of the Constitution of the United States, to suspend the privilege of the writ of *habeas corpus*. It is, in my judgment, a legislative and not an executive act, and the power is vested in Congress. Upon this question, it seems to me that the reasoning of Chief Justice Taney in *ex parte* Merryman is unanswerable; and in saying this, I accept as just the strictures of Professor Parker, in the article referred to, upon the decision there made. I agree that there is a plain distinction between the suspension of the writ in the sense of the clause of the constitution and the right of a military commander to refuse obedience when justified by the exigencies of war, or the *ipse facto* suspension, which takes place wherever martial law actually exists, which the Chief Justice seems to have overlooked.

But this kind of suspension, which comes with war and exists without proclamation or other act, is limited by the necessities of war. It applies only to cases where the demands upon the officer's time and services are such that he cannot, consistently with his superior military duty, yield obedience to the mandates of the civil authorities, and to cases arising within districts which are properly subjected to martial law. In cases of the latter description, it is probable that the civil magistrates would be bound to take judicial notice of the existence of martial law by which their functions are so far suspended; but as to the former, it would seem that the military officer should, if practicable, make return of the facts showing his excuse. The respondent in this case has made no such return, and this brings me to the next question.

Does martial law prevail at the present time in the State of Wisconsin? In using these words I adopt the distinction taken by Judge Curtis between military law and martial law; applying the former to those rules enacted by the legislative power for the government and regulation of the army and navy, and the militia when called into the actual service of the United States, and the latter to that government and control which military commanders may lawfully exercise over the persons and property of citizens and individuals not engaged in the land or naval service. Upon this question I entertain as little doubt as upon the other. I think it does not.

The powers of the President as Commander-in-Chief of the army and navy in time of war are strictly constitutional powers, so denominated by John Quincy Adams, who, I believe, has taken as broad ground in favor of the powers of war as any American statesman

or jurist. They are derived from the Constitution in the authority given to Congress to carry on war, and though not defined by that instrument, they are limited by the laws and usages of nations adopted in their full extent by the common law of England (*4 Bl. Com.* 87) and of this country. Of those laws and usages there is no principle better settled in modern times, as respects free or constitutional governments, than that martial law is restricted to those places which are the theatre of war and to their immediate vicinity. Modified by the necessities of war it is obvious it cannot operate beyond these bounds.

The precise limits of the jurisdiction of the military commander in cases arising near the scene of the strife may be a question for discussion, to be determined according to circumstances; but over remote districts and those not immediately connected with the operations of the contending armies, all courts and writers concur in saying that martial law cannot be extended. The true test in case of civil war would seem to me to be whether the civil authorities are able by the ordinary legal process, to preserve order, punish offenders, and compel obedience to the laws. If they are, then the military commander has no jurisdiction. If, on the other hand, through the disloyalty of the civil magistrates or the insurrectionary spirit of the people, the laws cannot be enforced and order maintained, then martial law takes the place of civil law whenever there is sufficient military force to execute it.

The resistance in which the petitioner was implicated was riotous but not insurrectionary. Saving the definition of martial law, which I think too broad, preferring that given by Professor Parker on page 501, I commend the views of Judge Curtis upon this question, not only for their general force and accuracy, but for the spirit of candor and sympathy for the national executive in these times of our trouble, and of patriotic devotion to country evinced by the learned author, which should characterize the criticism of all loyal citizens.

The power of the President to prescribe offences, or to make rules for the conduct of citizens in districts not subject to martial law, and to enforce them by fines or imprisonment, by whatever form of trial, I think not a question of discussion. This power, whenever possessed by the Federal Government, resides in Congress. Whether under the fifth article of the amendments to the Constitution, Congress declaring the offence, might have vested the jurisdiction in a court martial or military commission, in the case of the present petitioner, I need not inquire. Nothing of that kind has been done, and he seems not to be charged with any offence known to the laws of Congress.

These I believe to be the real questions presented, and in stating my convictions of the law I desire to add that they are given without the slightest disrespect to the President, who has, in all his actions, been governed by the highest motives of patriotism, public honor, and fidelity to the Constitution and laws. Fenced at the gloomiest period of our public misfortunes—when over fifty thousand of the noblest of the land, answering the summons, had fallen a sacrifice to the sacred cause of our nationality—when one division of the army of the Union, already most sadly repulsed, was threatened with complete overthrow by superior, almost irresistible numbers, and another, broken and wavering, was retiring before the restlessness and implacable foe—when the only way to national life, honor, and peace, lay through the fire and blood of battle—and when, in response to a recent call for additional forces, instead of the utmost loyalty and patriotism on the part of every citizen of the loyal States, each asking where he could be most useful or how he could best promote the welfare and safety of his country, there was reason to apprehend, in some quarters, factious and disloyal opposition—the proclamation in question is not a welcome subject of criticism.

As not unfrequently happens in the affairs of war, it is easier, sometimes most painfully so, with time for deliberation, to point out mistakes after they are committed, than to see and avoid them amid the difficul-

ties and dangers by which the military commander is at the moment surrounded. If, under these circumstances of national and executive embarrassment, the President has transcended his lawful authority, he has committed an unintentional error, which he will be the first to repair and the last to vindicate. My duty, however, compels me to judge his acts, not by his intentions, but by the Constitution and laws, giving a fair and reasonable scope to all the powers which they confer upon him.

It follows that in my judgment the return of Gen. Elliot shows no sufficient cause for the detention of the petitioner or why he should refuse to produce his body before this Court; but as the issuing of the attachment at the present time may lead to serious and most unfortunate collisions, which it is possible to avoid by a short delay, I deem it advisable, adhering to the precedent set by other Courts and Judges under like circumstances, and out of respect to the national authorities, to withhold it, until they shall have had time to consider what steps they should properly take in the case.

Many other cases of applications to the courts for the writ of habeas corpus occurred; in some of which it was granted, and in others, refused.

The arrests, some of which were flagrant, attracted so much attention that they exerted an influence upon the State elections near the close of the year, in which the Administration party was very seriously defeated. Released prisoners on their return to their residences were in many instances received with immense popular demonstrations.

On the 22d of November, therefore, the following order was issued by the War Department:

WAR DEPARTMENT,  
WASHINGTON, Nov. 22, 1862. }

*Ordered*—1. That all persons now in military custody, who have been arrested for discouraging volunteer enlistments, opposing the draft, or for otherwise giving aid and comfort to the enemy, in States where the draft has been made or the quota of volunteers and militia has been furnished, shall be discharged from further military restraint.

2. That persons who, by the authority of the military commander or governor in rebel States, have been arrested and sent from such State for disloyalty or hostility to the Government of the United States, and are now in military custody, may also be discharged upon giving their parole to do no act of hostility against the Government of the United States, nor render aid to its enemies. But all such persons shall remain subject to military surveillance and liable to arrest on breach of their parole. And if any such persons shall prefer to leave the loyal States on condition of their not returning again during the war, or until special leave for that purpose be obtained from the President, then such person shall at his option be released and depart from the United States, or be conveyed beyond the military lines of the United States forces.

3. This order shall not operate to discharge any person who has been in arms against the Government, or by force and arms has resisted or attempted to resist the draft, nor relieve any person from liability to trial and punishment by civil tribunals, or by court martial or military commission, who may be amenable to such tribunals for offences committed.

By order of the Secretary of War:

E. D. TOWNSEND, Assistant Adjutant General.

Indictments were now found in some of the States against the individuals who had executed these orders to arrest. In New Jersey the grand jury of Hunterdon county found bills of indictment against the U. S. marshal and

his aids, for arresting a citizen of that county. The marshal and his aids were arrested and put under bonds to appear at the term of the court in April, 1863. Similar proceedings took place in Ohio. The Congress subsequently in session passed an act authorizing President Lincoln to suspend the writ of habeas corpus, etc.

HARRISONBURG, the capital of Rockingham county, Virginia, is a small village situated in a fertile country, west of the southern termination of the Massanutten mountain. It is near Cross Keys, the scene of the battle between Gens. Fremont and Jackson, in the retreat of the latter from the pursuit of Gen. Banks across the Potomac. The population was about 1,500. It is the termination of the Manassas Gap railroad.

HOGG, THOMAS JEFFERSON, Esq., born at Norton, in the county of Durham, May 24, 1792, died at his residence, Clifton-road, St. John's Wood, August 27, 1862. He received the principal part of his education at the Royal Grammar School of Durham, under the late Rev. Dr. Britton, who was famed for the many able scholars he had sent to both universities. In January, 1810, he entered University College, Oxford, where commenced his intimate acquaintance with Percy Bysshe Shelley, whose biography he has not lived to complete. He was admitted to the bar at the Middle Temple in 1817, and for many years regularly attended the assizes and quarter sessions. In 1833 he was appointed one of the Municipal Corporation Commissioners for England and Wales, and subsequently, for more than twenty years, was the revising barrister for Northumberland and the northern boroughs. Few English scholars could surpass him in his thorough acquaintance with Greek and the Grecian authors, and he was also well read in the modern languages—German, French, Italian, and Spanish. He was the author of "Two Hundred and Nine Days; or, The Journal of a Traveller on the Continent," several essays in the "Edinburgh Review" and other periodicals, and two able articles in the last two editions of the Edinburgh "Encyclopædia Britannica"—viz., "Alphabet" and "Antiquities."

HOLLY SPRINGS, the capital of Marshall county, Mississippi, was a flourishing and beautiful village, 210 miles north of Jackson, the capital of the State, and situated on the railroad from New Orleans to Columbus, near Cairo, on the Ohio, called the Mississippi Central. It has been noted for the excellence of its schools and the intelligence of its inhabitants, and contains several churches and one bank. It was involved in the military operations of the year, and occupied by the Federal forces at two different periods. (See ARMY OPERATIONS.) Its population was about 5,000.

HOPE, Rev. FRED. WM., a clergyman of the Church of England, born in Portman-square, London, Jan. 3, 1797, died at the same place, April 15, 1862. He was educated at Christ

Church College, Oxford; graduated in 1820, and was ordained to the curacy of Frodesley, Shropshire. His health, however, proving insufficient for the duties of his profession, he was obliged to relinquish it, and henceforth turned his attention to scientific pursuits, for which he had a peculiar fondness. While in college he had devoted much attention to geology, and especially entomology, and, after leaving Oxford, pursued his zoological studies with great earnestness, extending his researches to every branch of animated nature. His success as a collector of English insects was very great, repeated reference being made to them in Stevens' great work on English insects and several other valuable publications upon that department of science. He did not, however, confine his attention to the insects of his own country, but formed, at great expense, an extensive collection, which became famous on the Continent for the numerous Indian, African, and Asiatic rarities amassed together. He was connected with several scientific societies, and his frequent contributions to their publications were of great value. His investigations followed the subject in all its branches, practical and historical. During the latter part of his life his health required a residence in the warmer parts of Europe, where he added to his collections fishes, crustacea, &c., as well as birds and shells. In 1849 he executed a deed of gift, making over his whole collection, as well as his library and engravings, to the University of Oxford, with a view of promoting the study of natural history in that institution. His donation likewise comprises one of the largest collections of engraved portraits and topographical illustrations ever formed. Of these the portraits cannot be fewer than 140,000, and the engravings of all kinds 100,000. The former are arranged in series, and composed of royalty, nobility, clergy, lawyers, statesmen, military and naval officers, authors, painters, sculptors, philosophers, medical professors, zoologists, botanists, geologists, &c. In the year 1855, the first stone of the new museum at Oxford was laid, on which occasion the honorary degree of D. C. L. was conferred on him by the university. In 1861, Mr. Hope further testified his devotion to the university by endowing a professorship of zoology.

HORNE, THOMAS HARTWELL, D. D., an English clergyman and author, born in London, October 20, 1780, died in the same city, January 27, 1862. His father was a barrister's clerk in the office of Mr. Graham, afterward one of the barons of the exchequer. Young Horne was educated at Christ's Hospital School, and made excellent proficiency in his studies; but, at the death of his father, when he was fifteen years of age, he was compelled to enter upon a life of labor for his own support and that of his younger brothers and sisters. For ten years he worked as a barrister's clerk for different employers, occupying his leisure hours, often far into the night, in study and literary

labor. He very early experienced some disquietude from the infidel views prevalent at that period, and, having settled in his own mind the question of the authenticity and inspiration of the Scriptures, he sought to aid others, and published, when about twenty years of age, a "Brief View of the Necessity and Truth of the Christian Religion," in two vols. 8vo., which, obscure as its author was, passed through several editions, and led to his subsequent great work. From this time onward, for the next fifteen or twenty years, he occupied his leisure hours (being employed through the day regularly as a barrister's clerk till 1806, for the next three years as private secretary to Joseph Butterworth, Esq., and from 1809 to 1823 as sub-librarian of the Surrey Institution) in editing or compiling a great number of works upon the most miscellaneous subjects, in order to add to his slender income the means of educating his brothers and sisters. It is said that at least 50 separate works were thus prepared by this patient toiler. In 1824 he received the appointment of senior assistant librarian in the department of printed books at the British Museum, which he retained till 1860. It was while connected with the Surrey Institution that he prepared and published the first edition of his great work, "An Introduction to the Critical Study and Knowledge of the Holy Scriptures," London, 3 vols. 8vo, 1813. This work was at once adopted in Europe and America as a text book for theological students, and brought its author into notice. It passed, during the author's lifetime, through ten successive editions, being brought up to the latest results of biblical criticism, and the last edition, issued in 1860, was in four bulky quartos. Over 15,000 copies were sold in England during Mr. Horne's life, and it was republished in several editions in the United States, and translated into most of the languages of Europe, and several of those of India. An abridgment of it, by the author, had also a very large sale. In 1819, Mr. Horne was ordained by Dr. Howley, then Bishop of London, to the curacy of Christ Church, Newgate-street, and subsequently became assistant minister at Wilbeck Chapel. In 1833, Dr. Howley, then Archbishop of Canterbury, appointed him to the living of a small church in Lombard-street, which he held till his death. The University of Pennsylvania conferred on him the degree of D. D.

HUNTSVILLE, the capital of Madison county, Alabama, is a beautiful town, situated on the Memphis and Charleston railroad, 116 miles south by east of Nashville. It contains numerous fine edifices of stone, churches and seminaries, and had a population of about 4,500. It was occupied during the night of the 8th of April by a division of Federal troops, under Gen. Mitchell. This was done so quietly that the unsuspecting inhabitants were not aware of what had taken place until the troops were in peaceable possession, when consternation seized them.

## I

ILLINOIS, one of the most fertile States of the West, bounded on one side by the Mississippi river and on another by the Ohio; has increased in population 860,481, in the ten years ending in 1860, when the total population was 1,711,981. The population of some of the cities of the State was as follows:

CITIES.	1850.	1860.	Increase.
Chicago.....	29,968	109,260	79,297
Alton.....	3,585	7,538	3,753
Freeport.....	1,436	3,529	2,093
Galena.....	4,004	3,138	2,189
Pekin.....	1,678	3,487	1,789
Peoria.....	5,095	14,045	8,950
Quincy.....	6,902	13,683	6,780

The number of white males was 898,941, do. females 805,350.

The number of deaths in the State during the year ending May 31, 1860, was 19,268. The most fatal diseases were consumption, croup, dysentery, fevers, and pneumonia.

The number of deaf mutes was 801.

The industrial products of the State were during the year ending June 1, 1860, as follows: iron founding, \$605,428; coal, \$964,187; lead, \$72,958; lumber, \$2,275,124; flour and meal, \$18,104,804; spirits, \$3,204,176; malt liquors, \$1,809,180; leather, \$150,000; boots and shoes, \$963,052; furniture, \$373,609. Annual product, \$56,750,000.

The value of real and personal property was \$871,860,282; increase in ten years \$715,595,276. The cash value of farms was \$432,581,072; do. farming implements and machinery, \$18,276,160. Land improvements, \$13,251,473.

Some of the most important productions of agriculture were as follows: horses, 575,161; asses and mules, 38,881; milch cows, 532,731; working oxen, 90,973; other cattle, 881,877; sheep, 775,280; swine, 2,279,722; value of live stock, \$74,484,621.

Wheat, 24,159,500 bush.; rye, 981,322 bush.; corn, 115,296,779 bush.; oats, 15,336,072 bush.; tobacco, 7,014,280 pounds; cotton, 6 bales of 400 pounds each; wool, 2,477,563 pounds; peas and beans, 112,624 bush.; potatoes, Irish, 5,799,964 bush.; do. sweet, 841,443 bush.; barley, 1,175,651 bush.; buckwheat, 345,069 bush.; value of orchard products, \$1,145,936; butter, 28,337,516 pounds; cheese, 1,595,368 pounds; hay, 1,834,265 tons.

There were 23 daily, 1 biweekly, 6 triweekly, 228 weekly, and 1 monthly political newspapers published in the State; and 5 weekly and 6 monthly religious newspapers.

The crops in the State during 1862 were abundant as usual, and with the loss of the Southern market in consequence of the war and the high price of transportation by railroad to the Eastern markets and the abundance of other freight, corn became at some points almost valueless, and was used as an article of fuel.

The convention elected at the close of 1861 to draft a new constitution for the State, assembled at Springfield in the beginning of January, 1862, and continued in session about three months. The constitution of the State then in force was adopted in 1841-'2, when the population of the State was about 478,183. In some of its details it was not suitable to the altered circumstances of the people. The instrument prepared by the convention failed to receive the votes of a majority of the people when submitted to them, and therefore did not go into operation. It extended the jurisdiction of the county courts; the finding of a jury was unnecessary for the prosecution of offences not punishable by imprisonment in the penitentiary; each county was to elect a prosecutor or county attorney. The number of members of the Legislature was increased from one hundred to one hundred and thirty-five. The restriction of the existing constitution upon the expenditures was wisely omitted in the new instrument. No fundamental law can be drafted with such foresight as to anticipate all future contingencies, and these restrictions have always led to embarrassment and subterfuge in legislation. The term of the office of governor was limited to two years, instead of four; soldiers in the field were allowed to vote. It secured a lien to the mechanic, also certain rights to married women, and an exemption of the homestead from execution for debt. It forbade any negro or mulatto to migrate or settle in the State after its adoption. It provided that no negro or mulatto should have the right of suffrage or hold any office in the State. It prohibited the creation of any banking corporation or association, and withheld from the General Assembly power to pass any law reviving, enlarging, extending, or renewing the charter of any existing bank or banking corporation. It prohibited the circulation within the State of any bank note, check, or draft as money, of a less denomination than ten dollars, and after the year 1864, of a less denomination than twenty dollars, and after the year 1866, of any bank note, check or draft of any denomination whatsoever, as money. It also contained the following addition to the Bill of Rights:

SEC. 30. The people of this State have the exclusive right of governing themselves, as a free, sovereign, and independent State, and do, and forever shall, enjoy and exercise every power pertaining thereto, which is not, and may not hereafter be, by them, expressly delegated to the United States of America, or prohibited to the State by the Constitution of the United States.

This expresses very clearly the views of the American people on the important question of State Rights, but, to avoid any, even the slightest misunderstanding, the convention also inserted this section immediately after the preceding:

Sec. 31. That the people of this State regard the Union of the States, under the Federal Constitution, as PERMANENT AND INDISSOLUBLE, from which no State has a constitutional right to withdraw or secede.

These two sections embody the principle. They clearly define the distinction between the State and the Federal Governments, the preservation of which has justified the beautiful expression in regard to this system that the States, under the Federal Government, are "distinct as the billows, yet one as the sea."

In relation to negroes the constitution of the State has for some years contained the following provision :

ART. 14. The General Assembly shall at its first session under the amended constitution pass such laws as will effectually prohibit free persons of color from immigrating to and settling in this State, and to effectually prevent the owners of slaves from bringing them into this State for the purpose of setting them free.

This constitution was submitted to the electors of the State in June for their approval. Some of its provisions were also submitted separately. The result of the vote of the people was as follows :

For the new constitution .....	125,050
Against the new constitution .....	141,118
For the article prohibiting banks .....	128,583
Against the article prohibiting banks .....	180,889
For the exclusion from the State of negroes and mulattoes .....	171,896
Against the exclusion of negroes and mulattoes ..	71,806
Against granting the right of suffrage or office to negroes or mulattoes .....	211,920
In favor of granting the right of suffrage or office to negroes or mulattoes .....	85,649
For the enactment of laws to prevent negroes and mulattoes from going to and voting in the State .....	198,988
Against the enactment of laws to prevent negroes and mulattoes from going to and voting in the State .....	44,414
For Congressional apportionment .....	125,740
Against Congressional apportionment .....	182,970

Thus while some of the provisions of the new constitution received a majority of the votes cast and were thereby approved, yet the instrument entire was rejected.

The only movement of importance in political affairs related to the choice of members of Congress at an election held on the 14th of October, and members of the State Legislature. The State being entitled to an additional member of Congress, under the new apportionment of Congress, and as the election took place before any session of the Legislature by which the State might be redistricted, this additional member was chosen by the electors of the whole State. A treasurer and superintendent of public instruction were also chosen by the electors of the whole State.

As usual, the questions of national politics formed the issue of the election, and the respective parties, of which there were two, held their conventions, nominated their candidates, and made their declaration of principles.

The Republican Convention assembled at Springfield, on Sept. 24. B. C. Cook was chosen president. It nominated E. C. Ingersoll for congressman at large, Newton Bateman for superintendent of public instruction, and Wm. Butler for treasurer, and adopted the following declaration of principles :

Whereas, The Government of the United States is now engaged in the suppression of a rebellion, the most causeless that has ever occurred in the history of nations; and whereas the successful and immediate suppression of the same demands the united and hearty cooperation of all loyal citizens, we, therefore, the Union men of the State of Illinois, do proclaim the following as the basis of our action :

*Resolved*, That we acknowledge but two divisions of the people of the United States in this crisis—those who are loyal to its Constitution, and are ready to make every sacrifice for the integrity of the Union and the maintenance of civil liberty within it, and those who openly or covertly endeavor to sever our country or to yield to the insolent demands of its enemies—that we fraternize with the former and detest the latter; and that, forgetting all our former party names and distinctions, we call upon all our patriotic citizens to rally for one undivided country, one flag, one destiny.

*Resolved*, That the preservation of constitutional liberty, the integrity of American soil, and the memories of three fourths of a century of peace and prosperity, such as before were never exhibited in the world's history, demand the prosecution of this war to whatever extent it may be necessary, or at whatever sacrifice may be required.

*Resolved*, That we cordially endorse the proclamation of freedom and confiscation of the President, issued September 22, 1862, as a great and imperative war measure, essential to the salvation of the Union; and we hereby pledge all truly loyal citizens to sustain him in its complete and faithful enforcement.

*Resolved*, That all laws now in force, passed for the purpose of crippling the latent resources of the rebellion, by confiscating the property of rebels, meet the hearty concurrence of this convention; and we shall hold all officers, both civil and military, responsible for a strict and vigorous enforcement of the same.

*Resolved*, That the maintenance of the Government and the preservation of national unity are the great end and purpose of the present war, and to accomplish these the rights of person and property in all sections of the country should be subordinate.

*Resolved*, That we admire and heartily commend the patriotic and efficient aid rendered by loyal Democrats to the present Administration, while we deprecate the course of political leaders, representing party organization, in finding fault with the Administration in the prosecution of the war, while they studiously avoid being harsh toward the conspirators of the South who are now attempting to sweep down the last vestige of constitutional liberty.

*Resolved*, That, while we are in favor of a system of direct taxation to any extent necessary to suppress the rebellion, maintain the public credit, and pay the interest on the national debt, we are, nevertheless, in favor of such modifications of the present law as may be found necessary to make it equitable in its operation.

*Resolved*, That, regarding the construction of a ship canal connecting the Mississippi and the lakes as a work of great national importance, demanded alike by military necessity and the wants of commerce, and calculated to unite more closely the different sections of our country, we would urge upon our representatives in Congress to use their best efforts to secure the passage of an act for the speedy accomplishment of this great national work.

*Resolved*, That the governor of this State, in his zealous and efficient labors to bring into the field the full quota of Illinois troops, and in the effort he has made to provide our soldiers with things necessary for their comfort, when sick and wounded, deserves and should receive the commendation and gratitude of the entire people of the State of Illinois.

*Resolved*, That the volunteers of this State who have so patriotically perilled their lives in the defence of our common country are entitled to the lasting gratitude of the people, and we hail with especial delight their noble heroism exhibited on every battle field from the Potomac to the Kansas.

The candidates nominated by the Democratic Convention were—for congressman at large, James B. Allen; for superintendent of public instruction, John P. Brooks; for treasurer, Alexander Starne.

As it is important only to show the chief points of national interest upon which the two parties were divided at this election, reference is here made to the resolutions adopted by the Democratic Convention in Indiana, on page 527, as illustrative of this difference of views with sufficient clearness. Both conventions were members of one and the same great party.

The votes of the citizens at the elections were given as follows:

The Republican vote for Congressman at large was...119,784  
The Democratic vote for Congressman at large was...186,060

Democratic majority..... 16,299  
The Republican vote for Treasurer was.....120,116  
The Democratic vote for Treasurer was.....186,662

Democratic majority..... 16,546

The votes for members of Congress were given as follows:

	Republican.	Democrat.
1st district.....	9,966	8,206
2d ".....	12,612	4,785
3d ".....	10,496	6,785
4th ".....	8,711	11,626
5th* ".....	11,638	11,020
6th ".....	10,604	8,419
7th ".....	10,004	11,871
8th ".....	11,443	12,808
9th ".....	No candidate	18,891
10th ".....	7,712	14,259
11th ".....	5,523	18,644
12th ".....	6,854	10,990
13th ".....	4,290	9,497

The Republicans elected three, and the Democrats eleven, members of Congress. The Legislature was elected as follows:

	Senate.	House.
Democrats.....	18	56
Republicans.....	12	29

At the election in Chicago, the largest city of the State, for mayor, in April, 1862, the votes were cast as follows:

	1862.	1861.
Democrat.....	7,509	6,601
Republican.....	6,186	8,274

The governor of the State is Richard Yates, whose term of office expires Jan. 1, 1865; the Secretary of State is Ozias M. Hatch, whose term expires at the same time. The debt of the State is \$12,337,381. The number of banks in the State at the close of the year was 18. Their circulation was fully secured.

The number of regiments sent by the State into the service of the United States, to the close of 1862, was 180 of infantry, 16 of cavalry, and 2 regiments and 7 batteries of artillery. The State has promptly furnished the troops called for by the Federal Government, without any drafting.

**ILLUMINATION, GAS and OILS.** Under this head will be presented certain important and recent additions to our knowledge respecting the materials employed for purposes of illumination, and also some of the latest processes in connection with the preparation of burning oils and of illuminating gases.

\* 612 Independent.

**Igniting Point of Coal Gas.**—Dr. E. Frankland has, in the "Journal of Gas-Lighting," &c., No. 250, a paper detailing very fully the experiments and observations of different authorities on the subject named; the following being the conclusions to which he is led:

1. Coal gas cannot, even under the most favorable circumstances, be inflamed at a temperature below that necessary to render iron very perceptibly red hot by daylight in a well-lighted room. But this temperature is considerably below a red heat visible in the open air on a dull day.

2. This high igniting power of coal gas under all circumstances, is due in a great measure to the presence of olefiant gas and luminiferous hydrocarbons.

3. The igniting point of explosive mixtures of the gas of coal mines is far higher than that of similar mixtures of coal gas; consequently, degrees of heat which are perfectly safe in coal mines, may ignite coal gas; and the safety-lamp is hence much less safe in coal gas than in fire-damp.

4. Explosive mixtures of coal gas and air may be inflamed by sparks struck from metal or stone. Thus, an explosion may arise from the blow of the tool of a workman against iron or stone, the tramp of a horse on pavement, &c.

5. Explosive mixtures of coal gas may also be ignited by a body of a comparatively low temperature, through the medium of a second body, whose igniting point is lower than that of coal gas. Thus, sulphur, or substances containing sulphur, may be inflamed far below visible redness; and the contact of iron below a red heat with very inflammable substances, such as cotton waste, may give rise to flame, which will then, of course, ignite the gaseous mixture.—The full paper appears in the "Journal of the Franklin Inst.," Aug. 1862.

**Origin and Treatment of Petroleum: Uses of its Products.**—The following instructive summary relative to the points indicated, is from a communication to the "Scientific American," by a member of the Chemical Society of Schenectady, N. Y.:

In regard to the origin of petroleum (rock oil), scientific authorities differ; but the theory most generally favored is, that it is the product of the slow distillation, at low temperatures, of organic matter in the interior of the earth; the vapors being condensed in certain fissures and the surrounding soil. The lake of Trinidad and the bituminous matter of the Dead Sea may also be referred to a similar source. But for how many centuries must this operation have been going on, to have effected such enormous results!

Of the many uses to which petroleum and its derivatives are applied, that of illumination is the most important; and the process of refining is exceedingly simple. The crude material is put into a large iron retort, connected with a coil of iron pipes surrounded by cold water,

called the condenser. Heat is applied to the retort, and from the open extremity of the condenser, a light colored liquid of a strong odor soon flows. This is naphtha, and is very volatile and very explosive. Some refiners mix it with the burning oil, and numerous accidents have resulted from such mercenary indiscretion. It is usually run into a separate tank. After the naphtha has passed over, the oil used for illumination distils off. Steam is now forced into the retort and the heavy lubricating oil driven over. There now remains a black, oily, tarry matter, sometimes used to grease heavy machinery, and a black coke, employed as fuel. There are, therefore, five substances separated in this operation, but only the first three are of any economic importance.

The naphtha is used as a substitute for turpentine in paints, or by repeated distillations the benzole is separated from it and employed to remove spots from fabrics. This, however, is rather a drug in the hands of the refiner.

The burning oil (called kerosene, and in England, paraffine), as it comes from the retort, is of a yellow color, and in order to remove this, it is placed in a large lead-lined cistern, and agitated with about ten per cent. of sulphuric acid. After the acid and the impurities have subsided, the oil is drawn off into another tank and agitated with four per cent. of soda lye. This last operation is to remove any acid remaining with the oil, and also to extract the residue of the coloring matter. In fact it is sometimes employed alone, and a very good oil obtained. The oil is now agitated with water to remove the soda lye, and is then ready for consumption. The colorless oil is by no means the most economical, but on the contrary more light is obtained from the yellow article.

The heavy oil is cooled down to 80° Fahr., when the paraffine (solid) crystallizes out, and is separated from the oil by pressing. It is further purified by another pressing and by alternate agitation, in a melted state, with sulphuric acid and soda lye. It is then moulded into candles. It is a curious fact that the composition of paraffine and of good coal gas is exactly the same.

In Egypt a substance derived from petroleum was used in embalming bodies; and in Persia and the neighboring countries asphaltum is used to cover the roofs of the houses and to coat the boats. In France asphaltic pavements have been successful in several cities, and for the protection of stone no material is better adapted. Mixed with grease the Trinidad asphaltum is applied to the sides of vessels, to prevent the borings of the teredo, and with quicklime it affords an excellent disinfectant. Among the products of the distillation of petroleum are naphthaline and kerosolene. The former is the substance from which is obtained aniline, the base of the beautiful colors, mauve, magenta and solferino. The latter has been proposed as a substitute for chloroform and

ether. Many other substances have been separated, but as yet none of them have been applied. As this is comparatively a new field, many discoveries may be confidently expected in it in the course of a few years.

*Paraffine (or Kerosene) Oils.*—At the request of the Manchester Sanitary Association, Mr. Ch. O'Neil examined many specimens of paraffine oils. About 25 of these were bought in Manchester, 3 or 4 of them being from the United States; and there were besides 14 samples from oil wells in Pennsylvania and Canada. One sample from London and another from Liverpool formed with air an explosive vapor at as low a temperature as 60° F., and were to be considered as decidedly unsafe. Three of the samples gave with air explosive mixtures at 85°; of the remainder, 4 formed explosive mixtures at about 100°; then 3 more at about 120°, and 20 by the time of reaching 150°. Of the last 20, 18 were manufactures of one firm in Manchester, that of Mr. Young, all whose oils were found safe; 2 of them were from America. Out of 32 samples, 20 were pronounced safe; 8 less so; 9 dangerous. Some of these oils, even of high specific gravity, are dangerous—specific gravity being thus shown to be no test of safety. Neither is the boiling point such a test; since many substances of high boiling points have still a very high diffusive power; coal naphtha, for example, which boils at 260°, can form an explosive mixture in air, and almost instantly, at 32°.

The illuminating power of paraffine (kerosene) oil is remarkably high. One gallon of Young's paraffine oil, weight about 8½ lbs., will give, according to Dr. Lethby's experiments, the light of 28½ lbs. of spermaceti candles, or of 27 lbs. of wax candles, or of 28½ lbs. of stearic candles, or of 40 lbs. of the best tallow candles.

For a valuable history of Petroleum or Rock Oil, with an appended note on the chemical composition of this oil and its relation to that of various coals, peat, woody fibre, &c., by Prof. T. S. Hunt,—and also for a paper on the "Explosibility of Coal Oils," by Mr. T. Allen, of R. I.,—the extent of which papers is too great to allow of a satisfactory abstract within the limits of this article, the reader is referred to the "Smithsonian Report," 1861. Mr. Allen, it may be remarked, traces the great explosiveness of the coal or rock oils, where it exists, to the fact of their not being entirely freed from the more volatile and extremely inflammable naphtha, benzole, benzine, &c., associated with them. Since crude petroleum and coal oils contain much naphtha, they partake in corresponding degree of its dangerous properties; and the careful and entire separation of all more volatile components by distillation, in preparing the so-called "kerosene," or other oils for burning, becomes a point of the highest importance.

In the autumn of 1862, the grand jury of the city of New York, taking into considera-



tion the increasing introduction of rock and coal oils, and products obtained by refining from these, and the facts of frequent explosions resulting either through imprudence or unavoidably, in cases of their being burned or stored for sale, recommended the passing of an ordinance prohibiting the storing of crude petroleum, &c., within the fire limits. The subject was discussed before several meetings of committees appointed by the Common Councils of both New York and Brooklyn, as well as the further question of fixing a vaporizing point for these oils, *i. e.*, a point any oil readily vaporizing below which should not be allowed for sale. It appears that finally no action was taken, at least in the former city, further than to the effect of prescribing an extremely small limit to the quantity of these oils allowed to be kept on sale at any one place and time. Some interesting facts, however, were brought out during the discussions. When the coal or earth oils are once on fire, the throwing on of water only aggravates the flames, by spreading the oils, which are lighter and float on the water, and bringing them more largely into contact with air. The practice of keeping these oils stored upon the walks, where the explosive mixture of their vapor with air outside the barrels, or within them when only partially full, may be accidentally ignited in many ways, was particularly reprehended as dangerous. By some who addressed the committees, it was claimed that the ordinary refined oils were quite as explosive as the crude. Mr. Tagliabue showed a sample of a purified oil which could not be lighted by a match, but which at 90° threw off an inflammable vapor, and exploded at 108°. Mr. Finch, a manufacturer, had experimented on the oils since 1854; he had found their vaporizing point to vary from 65° to 152°, the best petroleum he had ever burned vaporizing at the temperature last named. In England, and in the State of Ohio the vaporizing point fixed on is 100°; it is believed that this is also the point established in Brooklyn. It was proposed to fix the vaporizing point for New York at 120°, and by others at 110°—the lowest of these points being here never attained by the heat of summer; but no definite action on this subject appears finally to have been taken.

Dr. Frankland, in his account of illuminating materials and processes as illustrated in the exhibition of 1862, speaking of the new branch of industry—the preparation of burning and other oils from peat, coal, petroleum, &c.—remarks on the enormous development there shown to have taken place in this line of production within the past seven years. Besides the oils from various parts of Great Britain and France, others and of equally excellent quality were shown from the United States, and from Germany, Prussia, and Austria. The yield of petroleum by the oil wells of the United States surpasses that of any other part of the globe, that of the Oil Creek region alone, in the

year 1862, being estimated at not less than 71,000,000 gallons.

*Carburation of Gas.*—Mr. Haywood, engineer to the Commissioners of Sewers, London, and Dr. Letheby, have prepared for that body a report on the subject named, which appears in the "Chem. News," No. 105, and in the "Jour. of the Franklin Inst.," March, 1862. Experiments were made with a view to testing the value of the proposed application of the Carbureting Gas Company's process to the public lamps. The patent of this company is for placing near to the gas burners a receptacle containing coal naphtha; the gas passing through or over this, takes up, and becomes enriched by the addition of the volatile hydrocarbons contained in the naphtha—the illuminating power of the gas being thereby increased, and in a ratio determined mainly by the quality of the naphtha used. Chemical and photometrical experiments showed that the gain in illuminating power was, with different samples of naphtha, from 25 even to 77 per cent. In experiments with 12 lamps in Moorgate street, the equalization of the amount of light secured by burning 6 of these without and 6 others with the carbureting apparatus, being judged by the eye, and without careful measurement, and extended over 30 nights of June and July, the result was that the former burners consumed an average of 4.89 cubic feet of coal gas per hour, the latter an average of 2.09 cubic feet of the same gas carburetted per hour, the naphtha being in this case of the best quality. It was inferred that, for the warm months, 3 cubic feet of the carburetted gas may be considered about equal to 5 cubic feet of that not carburetted; and assuming the data applicable to all seasons of the year, the process applied to the 2,825 lamps within the city would effect a saving annually of about £2,825. In a final report on the subject, the gentlemen named conclude that the use of naphthalized gas (the best naphtha being employed) will secure an economy of from 40 to 50 per cent. in the volume of gas consumed; and they favor a practical trial of the method.

*Bassett's Carbureting Apparatus.*—For the carburation of gases, *i. e.*, the charging of them with some other substance in the state of gas, or vapor, and which is more rich in carbon than themselves, naphtha offers itself as the most convenient and effective material. A difficulty attendant on its use, however, is that the vapors which it most readily yields are such as at low temperatures, as under 80°, or certainly under 50° F., are re-condensed, thus leaving the gas little if at all improved, and clogging the pipes with the resulting liquid. To obviate this, attempts have been made to keep the pipe beyond the carbureting apparatus heated. But naphtha being in fact a combination of several hydrocarbons having different degrees of volatility, Mr. J. A. Bassett, of Salem, Mass., has devised a gas carbureting apparatus (patented July, 1862) in which he

takes advantage of this circumstance, cooling the gas before passing it through the naphtha, so that it may take up only the hydrocarbons of such high volatility as not to be likely to recondense even at low temperatures. The gas is cooled by causing it to flow through a long, labyrinthine passage, formed by placing one within another a series of cylinders between which annular spaces are left. Some naphtha is placed in the lower part of this cooler, and the gas finally escaping from it and partly charged ascends into a second vessel or tube filled with a porous material, which, being by capillary attraction kept saturated with naphtha, exposes this liquid in the most effectual manner to the gas rising through it. For this use, the inventor prefers the material known as porous carbon, and sometimes employed for filters. A valve is so placed between the two vessels, that the opening it allows for the gas shall be inversely proportional in area to the pressure and velocity of the current, thus serving to equalize the delivery of the gas; and another valve, nearly closing when the supply of naphtha in the apparatus diminishes to a certain extent, interrupts in this manner the flow of gas, and reduces the light, thus giving notice of the necessity of replenishing with the carburetting liquid.

*Illuminating Gases from Petroleum, or Coal Oil, or from their Derivatives.*—Petroleum and coal oil are alike mixtures of a variety of hydrocarbons, liquid (at common temperatures), or dissolved; and these components are to such an extent identical or closely allied in the two compound oils, that the latter may be taken as for many purposes, very nearly equivalents, the one of the other. Both of them offer in quite concentrated and convenient form the elements necessary to the production of illuminating gases. This is in yet higher degree true of certain derivatives or products separable from the rock or coal oils, as naphtha, benzole, kerosene, &c.; and in case of these latter, an additional advantage is, that the gas directly as produced is certain to be very much more pure than any coal gas can be, even after the best practical system of washing and purifying. Besides, the rock and coal oils are now to be had, the one in nature, the other as resulting in the manufacture of coal gas, &c., in very great abundance; so that, in some situations actually worthless or of merely nominal value, they are generally cheap in all places in which an actual demand for them could exist. In view of these facts, as would be expected, numerous methods and processes have been attempted, or are now in course of trial, for producing from the crude oils or their derivatives the desideratum of an illuminating gas, at once more convenient and certain in its manufacture, as well as more pure and also more economical in price, than the coal gas so generally in use. Of course, the gas so sought must be a permanent one, capable of being stored in gasometers and delivered without condensation through

pipes in the coldest weather; while it is further quite certain that, if an illuminating gas can be economically produced from these oils or their products, one element of its economy will be in the superior brilliancy of its light, due to the taking up of a larger percentage of the carbon so abundant in them.

In fact, these oils and their several components alike contain an excess of carbon over the hydrogen present, as compared with the proportions of these two elements required to produce even the *heavy*, and much more the *light* carburetted hydrogen, or the mixture of both, as usual in coal gas. If, now, in attempts at obtaining a gas from these oils, the effect of the process employed is merely to produce in whole or in part a vapor, in lieu of a permanent gas, that is, if the molecules of the vapors of the oils be not made by heat or by some other cause to assume a new arrangement and combination (so that the oil can be said to be destructively distilled), then, so far as a mere vapor is the product, this is quite certain to prove worthless and positively troublesome by recondensing at low temperatures. If, on the other hand, destructive distillation of the oils does take place, with generation of permanent gases, these are quite certain to be chiefly the light and the heavy carburetted hydrogen ( $C_2H_4$  and  $C_2H_6$ ) in mixture, and the latter, in view of the abundant carbon of the oils, in larger relative proportion than occurs in case of coal gas. But, further, the percentage of hydrogen in the oils being fixed by the composition of each of them, and always at a small limit, it follows that this fact will limit also the amount of the gases that can be generated, and that in attempting to convert the oils alone into gas, a considerable residue of carbon which could not be taken up in the formation of the gases must present itself after the process. So far as the making of gas is concerned, this is a waste of the material employed; and as a matter of fact, the destructive distillation of any one of the oils referred to shows such waste in the copious residue of carbon, in form of soot, or coke, &c. By the introduction, however, during gasification of the oil vapors, of the requisite addition of hydrogen from some extraneous source, the conditions of the moment favoring chemical union, it is safe to presume that a greatly increased proportion of the carbon will be taken up; indeed, it appears, from certain trials, that the whole of the carbon is taken up in gaseous form, if the supply of hydrogen be sufficient. In such case, while a pure and highly illuminating gas is produced, there is no loss of the material which can enter into its composition. Thus have been indicated the various aspects and conditions of the problem under consideration; that, namely, of the economical production of an illuminating gas from the oils already named. Some of the methods recently tried or now being developed with a view to such manufacture will now be described, the reader being left to judge how

far they severally succeed in meeting the actual requirements of the case.

*Gas from Petroleum Alone.*—Messrs. L. Davis & F. M. Parks patented, in 1862, a process for producing a permanent gas for general illumination, from petroleum at a very high temperature. They employ the crude petroleum, passing this through a double vertical retort, so that the oil may be subjected to a very high temperature at two rapidly succeeding intervals. The gas is permanent, but the account does not state what percentage of the petroleum is in this way convertible into gas, what amount of waste remains from the process, nor what is the exact chemical nature and illuminating power, and hence the actual cost and value of the gas obtained. Since the crude petroleum contains much water, if some material which will abstract the oxygen of the water be present in the retorts during the process, the liberated hydrogen must act to insure a large increase in the volume of combustible gases, although incombustible carbonic acid must probably, in that case, be mixed with them.

*Hill's Air Gas, Oleo-Water Gas, and Electro-Chemical Gas.*—Mr. Hill, of New York, secured, June 15, 1858, a patent for an air gas. The process consists in blowing air, oxygen, carburetted hydrogen, or hydrogen, over, into, or through an oil, such as petroleum, coal oil, naphtha, oil of turpentine, or even alcohol, and igniting the mixture at the orifice of a pipe or burner, a brilliant light being thus produced. By further diluting the oil vapors, by means of increasing the proportion of the gas blown into the oil, a more complete combustion results, with the production of little light, but of an intense heat, said almost to equal that of the compound blowpipe of Dr. Hare. The air gas in this form of combustion is stated to have been already applied as the fuel for driving steam engines, and the inventor is now adapting it to locomotives. By burning the diluted gas within a perforated platinum capsule, an extremely brilliant light is produced, and the platinum cup may be made of any required dimensions.

Mr. Hill's oleo-water gas was patented in 1861. In preparing this, a common gas retort is used, billets of pine wood being placed within an iron cage inside the retort; heat being applied, wood gas distils over (passing on its way through a washer, or purifier), until the wood is converted into charcoal. When the retort has attained a cherry-red heat, regulated streams of petroleum, or other gas-yielding oil, and of water, are allowed to flow into it. The heat suffices to convert the water into steam and the oil into vapor, as introduced. The steam parts with its oxygen to the red-hot charcoal (or, in part, it may be, to superfluous carbon in the oil vapor), and a considerable volume of a permanent illuminating gas passes over into the gasometer, the presumption being that the oil vapor has been destructively changed, combin-

ing in decomposition of the steam (water), and that the resulting gas—which, to the eye, burns with a white, clear, and brilliant flame—is rich in, or mainly composed of, the highly illuminating bicarburetted hydrogen or olefiant gas. It does not appear, however, that the gas produced has been chemically analyzed, the consumption and illuminating power exactly measured, nor, of course, the comparative cost and value determined. It must be added that the entire body of oxygen abstracted from the admitted water probably goes at the temperature of the retort to the production of its equivalent of carbonic acid, this product, if really the result, constituting so much incombustible or dead matter already in the gas, as prepared for consumption. A recent statement furnished by Mr. Charles Sears, chemist, gives the best proportions of the materials, for a good strong light, as, of paraffine oil (or other equivalent), one volume; of water, four volumes; the product, when heavy oil is used, being about 1,000 cubic feet of gas for two gallons of oil and eight gallons water. With a retort of 14½ x 12 inches, the product was about 200 cubic feet of gas per hour. When the residuum of oil distillates is used, the cost of material becomes merely nominal. It is also claimed that the cost of this gas, as produced from petroleum, needs not exceed forty cents per thousand cubic feet.

The electro-chemical gas is apparently only hydrogen gas set free from water, in the acid liquid of a battery of some thousand pairs, consisting of coils of copper wire and scrap iron successively connected in the manner required, and the whole placed within a vessel called a generator, the liberated hydrogen being subsequently passed through petroleum to be carburetted. The sulphate of iron resulting in the cells of the battery is said to pay the cost of the iron and acid employed.

*McDougall's Fixed Gas, and Atmospheric Gas.*—These gases, processes for which have been patented by Mr. S. T. McDougall, of New York, appear to be nearly or quite identical in principle and mode of preparation, as well as in their composition and employment, respectively, with Mr. Hill's "oleo-water" and his "air gas." It is claimed that the illuminating power of a jet in which is consumed one and a half cubic feet of the fixed gas per hour, is equivalent to that of fifteen sperm candles; and also, that the gas can be produced more cheaply than coal gas, and so as to be much cheaper than burning fluid, coal gas, or candles. Its specific gravity is declared to be about 900 (air 1,000), that of the best coal gas being from 850 to 470. The atmospheric gas, a mixture of vapor of some hydrocarbon with air, can be burned in places and seasons in which the temperature does not fall below 50° F., and it is said to afford a good and cheap light.

*Elmer's Pure Illuminating Gas.*—Dr. Wm. Elmer, of New York, patented, in 1862, a process in which he claims that from hydrocarbons

vaporized, and water, acted on in form of steam, by zinc, a permanent gas, consisting mainly or wholly of bicarburetted hydrogen, *i. e.*, olefiant gas, is produced. Olefiant gas consists, by weight, of .86 of carbon and .14 of hydrogen. The percentage of carbon in petroleum, naphtha, &c., is always greater than this, so that, while those oils simply vaporized by heat seldom or never result in a permanent gas, it is further true that, owing to the excess of carbon, the vapors, when burned, are liable to smoke, and the flame lacks brilliancy. Dr. Elmer proposing to supply the deficiency of hydrogen in the oil vapors by liberating that gas from steam during oxidation of iron filings, Dr. Levi Reuben, of New York, suggested to him, as preferable, the plan of liberating the hydrogen by oxidation of zinc, which readily sublimes at the heat required for the gas process, so as to mingle freely with the steam, and secure rapid oxidation and a free supply of the requisite hydrogen, but which has especially the advantage of affording incidentally, in the resulting white oxide of zinc, a product having a sure commercial value, and one which would, therefore, go far toward paying the cost of materials and labor. A simple calculation showed the proportions of zinc, water, and a given oil required, in order to set free just the additional percentage of hydrogen necessary, if such chemical union be supposed to take place, to convert the entire carbon of the oil into its equivalent of olefiant gas; and, slight volatile impurities in the oil excepted, the gas so produced must be almost perfectly pure. The suggestions and data being adopted, the invention consists essentially in their application and working out in practice.

It is presumed, though (it appears) not yet proved by chemical tests, that the product in this process consists nearly, or altogether, of olefiant gas. Substantially, the method of producing the gas is as follows:—1. Vapor of water being admitted into a retort at white heat, in which zinc has been brought to the state of sublimation, oxidation of the metal occurs, the white oxide of zinc produced ascending, and being caught in suitably arranged boxes, so as to be saved, the hydrogen of the water which is meanwhile set free passing on into a second, and less highly heated, retort; 2. Into this second retort, the required relative proportion of benzole, petroleum, or any suitable liquid hydrocarbon, is at the same time continuously admitted, its conversion into vapor at once taking place; 3. The hydrogen gas and the oil vapor being thus continually supplied in this retort, and exposed in it to an extremely high temperature, a corresponding volume of a permanent gas (probably olefiant gas) is continuously and rapidly formed and delivered. The gas resulting is, at least, incondensable, and capable of being stored; while the second retort after the process needs not contain any residue of carbon; and further, if the zinc be volatilized in sufficient quantity, no oxygen needs

pass over into the second retort, and if it do not, no worthless carbonic acid can enter into the gas product obtained. In the apparatus, the steam is supplied by a small boiler within the furnace, and just beneath the first retort, and in order to insure its entering the retort in a state in which no condensation will occur, the steam is superheated by passing on its way through a coil of pipe exposed to the heat of the furnace. In some trials of this method, in which, in the earlier part of the process, a deposit of carbon in powder did occur in the second retort, it was found that, the heat being sufficiently great, and a stream of hydrogen alone being subsequently for a time admitted, all of this solid deposit of carbon was cleanly taken up and carried over in gaseous form into the gasometer. This fact appears incidentally to confirm the theory of the formation of the gas, and of its character already given; and the obtaining of an illuminating gas in this way from hydrogen and finely divided solid carbon (soot) has been included in the patent. An important advantage of the method of gas making now described is in the circumstance that since (if properly conducted) no oxygen can gain access within the generating retort, not merely is there no worthless product of combustion already in the gas as made, but there can, of course, occur no waste whatever by burning up in the retort of a portion of the gas, as too generally occurs in the making of coal gas: the gas formed is protected from chemical agencies, and the whole of it must be delivered and secured. The gas as produced in the trials thus far made by Dr. Elmer, gives a white, solid, intense, and beautiful light; but exact tests of consumption of material, illuminating power, &c., appear not yet to have been made.

*Air Light for Locomotives.*—Dr. George Hand Smith, of Rochester, N. Y., has invented an apparatus for burning any permanent gas, as ordinary coal gas, in such way as to secure an intense heat, and the ignition to whiteness of a small cylinder of lime, through means of supplying to the burning gas an abundance of oxygen, by mechanically forcing out in connection with the issue of gas from each burner a jet of atmospheric air, and which, previously to its escaping, has been also highly heated. In a word, his invention consists in applying the principle of the common forms of air or atmospheric light, in lieu of the more expensive oxygen and hydrogen gases, and with the addition of heating the supplied air, to the production of a lime light. His arrangement appears thus far to have been expressly designed for use on railroads. The cylinder of lime being fixed at the focus of the parabolic reflector employed for projecting the light, as now, in front of the locomotive, the lime is rendered incandescent by burning in a circle surrounding it and directed upon it four jets of the compound gas described, and issuing from as many separate burners. Two gas holders

placed beneath the engine communicate with these burners by means of pipes, their capacity being considerably above the requirements of a single trip. The charging of these before starting occupies less time, and is more conveniently accomplished, than the filling and care of the lamps previously in use. The flow of air and gas is controlled by regulators and stop-cocks at the command of the engineer. The peculiar economy, in view of its great brilliancy, of this light, arises from the circumstances that the ignition of the lime cylinder is purely an effect of heat, so that there is no attempt to secure brightness in the burning gas jets, but heat only; and to effect this latter purpose, the air, simply taken in from the atmosphere and warmed, constitutes much the larger portion of the compound jet, the coal gas, which alone costs, being consumed in a very small amount. The inventor states that, while the head lights previously in use on the Central Railroad, requiring oil, wicks, and chimneys, and the first of these costing 6½ cents an hour, were maintained at an expense each of about \$108.75 per annum; on the other hand, the consumption of gas in the new light not exceeding in expense 1¼ cents an hour, these lights, which are also more brilliant, need not cost more than \$26.87 each per annum.

*Lampe Eolienne.*—This new lamp, which, it is said, will soon be on sale, and which is intended for the combustion, not only of all the hydrocarbon oils that can be burned in lamps now in use, including whale oils, but also of those heavier oils to the employment of which the common styles of lamps are not adapted, is the invention of M. B. De Keravenan, a French engineer. The perfect combustion, and without smoke, of the heavier and highly carbonaceous oils, as well as of others, which is secured in this lamp, is effected by means of the forcing upward, within a tube rising through the middle of the lamp, and discharging directly in connection with the wick and flame, of a continuous current of air impelled by a fan wheel or vane driven by clockwork—the mechanical arrangement for the purpose being placed within the base of the lamp, and out of sight. The motive power is, of course, that of a spring; and the mechanism, like that of a clock, requires to be wound up at certain intervals. The current of air is thrown from the tube against the inner side of a cone placed upon the burner, and is thus deflected into or upon the flame; and it is stated that, as a consequence of this arrangement, the flame is rendered pure, white, and intense, as well as almost fixed, *i. e.*, well nigh free from flickering; while it does not smoke even where there are draughts of air, or on being carried about the room. The current of air is usually one of considerable amount; but the quantity can be regulated by a valve controlling the admission of air, and the flame can in this way be varied in color from white to yellow, orange, or reddish. The perfect combustion removes the possibility of an

odor of the oil from the flame; while danger of explosion is said to be obviated by the cooling effect of the air current in its passage upward, and through the cap of the lamp, and which prevents the heating of the vapor forming over the liquid within it. Much time and study are said to have been devoted to the invention and perfection of the mechanism and parts of this lamp, in order to adapt these to accomplish in the most satisfactory manner the purposes to be attained. The size of the flame obtained may, by suitably proportioning that of the wick, be very greatly increased; so that the light is adapted to a variety of uses, from that of the portable house lamp, to that of the lights of docks, steamboats, cars, locomotives, and even of lighthouses. Though the new lamp is less likely to be made of small sizes, or to be cheap, it will, of course be likely to prove a desirable one where lamps of a large size are required, through the relatively increased brilliancy and economy of the light, and the less unwholesome character of its products, resulting from the complete combustion of the oils, as well as through its saving the inconveniences and disfigurement of the glass chimney.

INDIANA, situated north of the Ohio river, and west of the State of Ohio, had in 1860 a population of 1,350,428, which was an increase of 862,012 since 1850. The increase in the population of some of the principal cities and towns was as follows:

CITIES AND TOWNS.	1850.	1860.	Increase.
Fort Wayne.....	4,252	10,388	6,106
Indianapolis.....	8,084	18,611	10,527
La Fayette.....	1,215	9,887	8,172
La Porte.....	1,824	5,028	3,204
Richmond.....	1,448	6,608	5,160

The number of white males was 698,848; do., females, 646,862.

The mortality during the year ending May 31, 1860, was 15,205. The most fatal diseases were consumption, croup, fevers, and pneumonia.

The industrial products of the State were as follows: iron founding, \$168,575; coal, \$27,000; lumber, 3,169,848; flour and meal, \$11,292,665; spirituous liquors, \$8,358,560 gallons; malt do., 66,338 bbls.; cotton goods, \$349,000; woollen do., \$695,370; leather, \$300,387; boots and shoes, \$1,084,341; furniture, \$601,124; fish, \$17,500. Total, \$48,250,000. Value of real and personal property \$528,835,371, being an increase during the preceding ten years of \$326,185,107. The cash value of farms was \$344,902,776. The amount of some of the productions of agriculture was as follows: horses, 409,504; asses and mules, 18,627; milch cows, 491,038; working oxen, 95,982; other cattle, 582,990; sheep, 2,157,375; swine, 2,498,528; value of live stock, \$50,116,964; wheat, 15,219,120 bushels; rye, 400,226 bush.; corn, 69,641,591 bush.; oats, 5,028,755 bush.; tobacco, 7,246,182 lbs.; wool, 2,466,264 lbs.; potatoes, Irish, 8,873,-

180 bush.; do., sweet, 201,711 bush.; butter, 17,934,767 lbs.; hay, 635,322 tons; maple sugar, 1,515,594 lbs. There were 18 daily, 5 biweekly, and 154 weekly political papers published in the State in 1860, and 3 weekly and 8 monthly religious papers.

The number of miles of railroads in operation is 2,169; cost of construction, \$71,864,304.

The governor of the state is Oliver P. Morton, whose term of office expires on the 1st of January, 1865. The secretary of State is James S. Anthon. The judiciary of the State consists of 4 supreme court judges, 14 circuit judges, and 21 district judges of common pleas courts.

The receipts into the treasury of the State to October 31, the end of the fiscal year, together with the balance of the preceding year on hand, were \$3,857,450, and the expenditures \$2,974,976. Balance \$876,474. The debt of the State is \$8,755,453. The State tax is two mills on a dollar, and a poll tax of 50 cents. The banking institutions of the State consist of the State Bank and its branches; in all 21 banks, besides 18 free banks. Their circulation at the close of the year was \$6,660,000.

The State election is held on the second Tuesday in October. At the State election, in 1862, members of Congress, one half of the State Senate, and all the members of the House of the Legislature were to be elected. Two distinct parties are organized in the State, which are known as democrats and republicans, the latter belonging to the party which elected the officers of the Federal Government.

The democrats held a convention at Indianapolis on the 8th and 9th of January, 1862, being the first held by them since 1860. Thomas A. Hendricks presided. A series of resolutions was adopted, asserting that the restoration to power of the democratic party could alone preserve the Union, and endorsing the principles heretofore put forth by the national conventions of that party; they declared that the present civil war had mainly resulted from the slavery agitation of a geographical party in the North, producing its counterpart in the South of secession, disunion, and armed resistance to the Government; condemning the course of the republicans in the Congress which terminated March 4, 1861, for the rejection of all peace propositions; that peace and harmony would now reign had the party in power shown the same desire to settle the internal disputes that it recently exhibited to avoid a war with England; that the republicans have fully demonstrated their inability to conduct the Government through the present difficulties; denouncing all violations of the Constitution and usurpation of power; regarding the *habeas corpus*, and the imprisonment of citizens of the loyal States as flagrant violations of the Constitution; that the seizure of Mason and Slidell was either legal or illegal; if the former, the nation has been humiliated by their surrender under threat; if the latter, they should have been delivered up before their imprisonment.

The convention also nominated for secretary of State, James S. Anthon; for State treasurer, Matthew L. Brent; auditor of State, Joseph Restine; attorney-general, O. B. Hord; superintendent of public instruction, M. B. Hopkins.

On the 30th of July the same party held another convention at Indianapolis, at which a series of resolutions were adopted, the principal points of which are shown in the following extracts:

That the Constitution, the American Union, and the laws made under and by the authority of the Constitution, must be preserved and maintained in their proper and rightful supremacy; that the rebellion now in arms against them must be suppressed and put down, and that it is the duty of all good citizens to aid the General Government in all measures necessary and proper to that end.

That the democracy of Indiana, with patriots everywhere, have made and will continue to make every sacrifice to the end that the rebellion may be suppressed, the supremacy of the Constitution maintained, and the Union under it preserved; but they are unalterably opposed to a war of conquest or subjugation, and they will never consent that the war on their part shall be waged for the purpose of interfering with the rights or overthrowing the established institutions of any of the States. In the language of Senator Douglas, uttered at Chicago a few days before his death, "We must not invade constitutional rights. The innocent must not suffer, nor women and children be the victims. Savages must not be let loose."

That we protest, in the name of ourselves and of our children, and in the name of all that is dear in the future of our beloved country, against the mischievous measures of negro emancipation in the District of Columbia, and the payment for such negroes out of the National Treasury; and we further protest against the resolution of Congress pledging the nation to pay for all negroes which may be emancipated by the authority of any of the Southern States; that we regard such measures, involving as they do an expenditure of two thousand five hundred millions of dollars, as measures of transcendent enormity, and fruitful only of national beggary to the land we love; that we are unalterably and unconditionally opposed to all schemes having for their object, immediate or remote, the taxation of the white man for the purchase of negroes anywhere; that we deny the constitutional right of the President or Congress to adopt a policy which taxes white labor to pay for negroes, or which would make the Government or people slave dealer, a policy which, if not arrested by the votes of the people, will entail upon unborn generations of our kindred a debt more overwhelming and appalling than ever cursed any nation of ancient or modern times.

That, in opposition to measures of this kind, we desire to interpose the peaceful and powerful agent, the ballot of a free people, and say, in the language of another, "We will neither surrender our rights nor forsake them. We will maintain our constitutional liberty at all hazards, and as a necessary step toward that end, we will maintain the Union in like manner. We are for the Constitution as it is, and Union as it was."

That, in the language of the resolution of the conservative members of Congress, the doctrines of the secessionists and of the abolitionists, as the latter are now represented in Congress, are alike inconsistent with the Constitution, and irreconcilable with the unity and peace of the country. That the first have already involved us in a civil war, and the others (the abolitionists) will leave to the country but little hope of the speedy restoration of union or peace.

That the happy accord of the Border State Union men of Kentucky, Maryland, Missouri, Delaware, and western Virginia, with the democratic delegations in

Congress, in their joint efforts to arrest the tide of fanaticism in both houses, has filled all national hearts in this State with sentiments of deep affection for our brethren of those gallant commonwealths, and we hereby pledge to them and the country our best efforts to secure to the councils of the nation statesmen who will labor to restore the union of the States on the basis and in the spirit of our matchless and revered Constitution,

That, the people of Indiana having inhibited, by the State constitution and law, the entrance of free negroes and mulattoes into this State, and as the present disturbances on our border are likely to bring in an influx of that population from neighboring States, we respectfully ask the public authorities of Indiana to see that the constitution and laws are properly enforced on that subject. When the people of Indiana adopted that negro exclusion clause by a majority of ninety-four thousand votes, they meant that the honest laboring white man should have no competitor in the black race—that the soil of Indiana should belong to the white man, and that he alone was suited to her free institutions.

That we approve of and endorse the resolutions drawn by Hon. John J. Crittenden, and approved by the conservative members of Congress on the 22d of January, 1861, as a clear and just declaration of the objects which ought to be had in view by the American people in the present fearful emergency of their national affairs.

The republican convention assembled at Indianapolis on the 18th of June. It was designated a Republican Union Convention, thereby intending to embrace all persons who were disposed to unite with the republicans in the work of sustaining the Union and the Constitution. Gov. O. P. Morton was elected president of the convention. Wm. A. Peele was nominated for secretary of State; Albert Lang for auditor; Jonathan S. Harvey for treasurer; Dulaney E. Williamson for attorney-general. The following declaration of principles was made:

*Whereas*, the National Government is engaged in a war waged against it by its enemies for the avowed purpose of its destruction and the subversion of our republican form of government, therefore,

*Resolved*, That the present civil war was forced upon this country by the disunionists in the Southern States, who are now in rebellion against the Constitutional Government; that in the present national emergency, we, the people of Indiana, in convention assembled, forgetting all former political differences, and recollecting only our duty to the whole country, do pledge ourselves to aid with men and money the vigorous prosecution of the present war, which is not being waged upon the part of our Government for the purpose of conquest, subjugation, or the overthrowing, or the interfering with, the rights or established institutions of any of the States, but to suppress and put down a wicked and causeless rebellion, defend and maintain the supremacy of the Constitution, and to preserve the Union as established by our patriot fathers, with all the dignity, equality, and rights of the several States unimpaired; and when these objects are fully accomplished, and not before, we believe the war ought to cease; and that we invite all who coincide in these sentiments to unite with us in support of the ticket this day nominated.

*Resolved*, That we demand and expect of our executive and legislative bodies, both State and National, an economical administration of governmental affairs, and the punishment of fraud against the Government, as well as the fearless discharge of their duties.

*Resolved*, That so long as patriotism, courage, and love of constitutional liberty shall be honored and revered among the people of the United States, the

heroic conduct of the soldiers of the Union who have offered their lives for the salvation of their country, will be remembered with the most profound feelings of veneration and gratitude; and that we now tender to them the warmest thanks and lasting gratitude of every member of this convention; that we tender to the 60,000 volunteers of Indiana our heartfelt congratulations, and hail with pride the fact that upon every battle field they have displayed the bravery of patriots in defence of a glorious cause; and we pledge them that, while they are subduing armed traitors in the field, we will condemn at the ballot box all those in our midst who are not unconditionally for the Union.

The vote of the electors, estimated by congressional districts, was as follows:

Districts.	Secretary of State.		Congressmen.	
	Athon, Democrat.	Peele, Republican.	Democrat.	Republican.
First .....	12,982	9,078	11,062	9,889
Second .....	10,425	6,929	10,911	6,211
Third .....	11,529	10,127	11,524	10,124
Fourth .....	10,906	8,027	10,926	7,928
Fifth .....	7,157	10,490	7,414	9,272
Sixth .....	11,514	12,586	11,054	12,525
Seventh .....	12,545	9,990	12,517	10,086
Eighth .....	11,838	12,114	11,751	12,005
Ninth .....	14,966	14,585	14,546	14,775
Tenth .....	12,414	11,987	12,808	11,917
Eleventh .....	19,057	12,473	12,142	12,219
Total .....	127,977	118,886	123,181	116,679

Majority for Athon, 9,801. Majority for democratic congressional ticket, 11,462.

In the 1st, 2d, 3d, 4th, 7th, 9th, 10th, and 11th districts the democrats elected the members of Congress; in the 5th, 6th, and 8th districts the republicans elected the members of Congress.

The provisions of the constitution of the State, relative to the immigration of negroes or mulattoes, are as follows:

Sec. 1. No negro or mulatto shall come into or settle in the State after the adoption of this constitution.

Sec. 2. All contracts made with any negro or mulatto coming into the State contrary to the provisions of the foregoing section shall be void; and any person who shall employ such negro or mulatto, or otherwise encourage him to remain in the State, shall be fined in any sum not less than ten dollars nor more than \$500.

Sec. 3. All fines which may be collected for a violation of the provisions of this article, or of any law which may hereafter be passed for the purpose of carrying the same into execution, shall be set apart and appropriated for the colonization of such negroes and mulattoes and their descendants as may be in the State at the adoption of this constitution, and may be willing to emigrate.

Sec. 4. The General Assembly shall pass laws to carry out the provisions of this article.—*Constitution of Indiana*, art. 13.

Sec. 6. All contracts made with negroes or mulattoes who shall have come into the State of Indiana subsequent to the 1st day of November, A. D. 1851, are hereby declared null and void.

Sec. 7. Any person who shall employ a negro or mulatto who shall have come into the State of Indiana subsequent to the 31st day of October, in the year 1851, or shall hereafter come into the said State, or who shall encourage such negro or mulatto to remain in the State, shall be fined in any sum not less than ten dollars nor more than \$500.—*An act to enforce the thirteenth article of the Constitution of Indiana*.

The military spirit manifested by the people

of Indiana, and the alacrity with which they took up arms was mentioned in the "Cyclopædia" for 1861. No flagging was indicated during 1862 in their efforts to perform the duty of the State. Upon the first call of the President for three hundred thousand men, on July 7, the governor immediately issued an address to the citizens, in which he said: "Again I call upon the loyal and patriotic men of Indiana to come forward and supply the quota due from our State. Up to this hour Indiana occupies a most exalted position connected with the war. Her troops have been in almost every battle, and have behaved with uniform and distinguished gallantry. Never before has the State held so proud a place in the opinion of the world, and it should be the prayer and effort of every loyal citizen that she may not now falter, and that nothing may hereafter occur to detract from her well earned honors. But while we are justly proud of the high rank to which Indiana has attained, we should never forget that our allegiance and highest duty are due to the nation, of which Indiana is but a part. That in struggling for our National Government, we are contending for our national existence, honor, and all that is dear to freemen, and that in this struggle we must succeed at whatever cost. That it is the duty of every State to furnish promptly her full proportion of the military force called for by the President, and that in doing so she has no right to dictate the terms of his military policy, or prescribe conditions precedent upon which such force shall be furnished. To do so would be to recognize the odious doctrine of State Rights, as it has been taught by rebel politicians for many years, and which is but another name for secession, and the cause of all our woe."

Liberal bounties were offered, and volunteers accumulated rapidly. The second call for three hundred thousand men on the 24th of September, for nine months, offered some special attractions which induced many to enlist who otherwise would not have entered the service under the first. The term of service in the first instance was for three years or the war; in the second it was only for nine months. The bounties in many places were alike for each. Consequently it became necessary to resort to the militia draft, which created considerable dissatisfaction. Under the first call 31½ regiments of infantry, 2 of cavalry, and 2 batteries were raised. The whole number of troops mustered into service from the State up to the close of the year was 102,700, of whom 8,008 were drafted men. The expenditure of the State for war purposes was \$1,979,248.

INGERSOLL, CHARLES JARED, an American statesman, born in Philadelphia, Oct. 3, 1782, died in that city Jan. 14, 1862. He was a son of Jared Ingersoll, an eminent lawyer, and one of the signers of the Declaration of Independence. After completing his collegiate course he studied law, and was admitted to practice before he became of age. Not long after, he visited Europe, and became attached to the

American embassy to France. In 1818, he represented the old Northern Liberties district of Philadelphia in Congress. In 1815, President Madison appointed him United States District Attorney in Philadelphia, in which capacity he served until removed by General Jackson, in 1829, and shortly afterward was elected to the Legislature of Pennsylvania. In 1827, he was a member of the State Convention, and, in 1829, of the National Assembly for the Encouragement of Domestic Manufactures. In 1837, he was a member of the convention elected to revise the State Constitution, and made the reports on currency, judiciary, &c. In 1840, he was reelected to Congress, and served until 1847, when he was nominated by President Polk as United States minister to France, but the Senate refused to ratify the nomination. He was not only prominent as a politician and statesman, but was an author of some distinction, and his productions show a wide range of talent as well as of learning and literary taste. He wrote on constitutional law, as well as history, and, in early life, was the author of "Inchiquin's Letters," a production of much merit. He also wrote a "History of the War of 1812," "Chiomara," a poem, "Edwy and Elgiva," a tragedy, "Historical Sketch of the Second War between the United States and Great Britain," and, more recently, had prepared for the press "A History of the Territorial Acquisitions of the United States."

INSURANCE COMPANIES, during the year 1862, have not apparently suffered by the fact of war, notwithstanding the diminution in some branches of business and the reduced stocks of some descriptions of goods to be insured. The losses by fire have, however, been very heavy in the Northern States, and the marine losses, considering the diminished transportation of Southern products, have been considerable. The large losses sustained by the merchant marine from the enemy's cruisers have been covered by war risks to some extent, but the aggregate losses of the New York marine companies have been less than in the previous year:

COMPANIES.	Premiums rec'd during the year.	Premiums earned during the year.	Losses for the year.
Atlantic.....	\$5,116,444 87	\$4,485,258 68	\$2,094,013 17
Commercial....	862,964 62	897,880 89	219,084 66
Columbian.....	815,521 44	735,886 89	411,018 61
Great Western..	1,642,816 48	1,880,959 18	992,957 15
Mercantile.....	1,069,194 28	1,041,005 09	638,422 58
Neptune.....	866,680 98	376,691 20	260,057 42
New York.....	585,591 50	562,797 87	358,815 41
Orient.....	881,170 84	400,550 51	225,474 28
Pacific.....	591,508 90	523,769 21	258,568 85
Sun.....	1,710,158 26	1,629,089 61	1,141,564 29
Union.....	481,384 57	449,975 50	186,920 88
Washington....	229,881 82	225,656 99	125,596 94
Total, 1862...	\$18,802,998 81	\$12,148,784 07	\$6,557,766 44
" 1861....	15,521,840 20	12,827,911 92	7,902,168 58
" 1860....	17,859,948 16	12,620,210 04	10,748,814 28

This result for the year has been encouraging, and some of the companies have greatly improved their condition. The scrip dividends have ranged from 8 to 40 per cent., except for



three companies which have made no scrip dividends, two of them, however, paid cash dividends of 5 per cent. In the aggregate of the companies the net premiums are \$5,290,968 in excess of the losses; in 1861 they were \$4,922,000 in excess of the losses, and in 1860 \$1,872,000 only in excess of the losses. In other words the losses have declined \$3,891,000, while the earned premiums have only diminished \$472,000. The war has not apparently been adverse to the interests of the New York companies. In Massachusetts the reverse is the case in some degree. The premiums have not exceeded the losses to the same extent. The risks and losses in Massachusetts have been as follows:

COMPANIES.	Risks.	Losses.
In 17 Stock Companies.....	\$38,742,485 00	\$1,247,962 61
In 12 Mutual Marine and Mutual Fire and Marine .....	55,717,341 50	2,391,975 07
Total Marine.....	\$94,460,376 50	\$3,639,937 68
" 1861 .....	94,024,701 50	8,451,520 23
" 1860 .....	114,350,668 00	8,714,063 81

The losses this year as compared with the risks are much greater than in 1860. The marine losses for the year 1862, including the vessels captured by the enemy, were as follows:

MONTHS.	Steamers.	Ships.	Barqs.	Brigs.	Schooners.	Number of vessels.	Estimated loss.
January...	4	16	18	90	27	95	\$1,825,600
February...	2	25	28	18	81	109	1,529,200
March.....	4	49	40	82	57	133	2,240,300
April.....	5	23	34	14	24	96	1,416,900
May.....	2	18	9	14	17	63	1,785,700
June.....	2	10	11	6	15	44	950,000
July.....	2	11	11	14	10	48	647,000
August....	5	6	6	6	8	28	428,000
September...	2	11	6	12	19	50	616,000
October....	5	19	19	12	25	78	1,412,000
November...	—	18	31	18	28	78	1,716,000
December..	10	27	17	27	56	137	1,964,000
Total....	44	233	219	189	825	1,010	\$16,590,600
" '61.	49	289	182	163	822	928	18,980,650

The trade and values transported on the lakes were very large in 1862 by reason of the turning of produce eastward from its usual southern route, and that circumstance has swollen the aggregate of inland transportation risks.

The fire risks for the year have also increased, but, although there were three very large conflagrations, the aggregate of losses has been less than usual. In the month of January two large fires occurred in New York, involving a loss of \$650,000. In February, one in Boston destroyed \$1,000,000, and one in Bowling Green, Kentucky, \$1,000,000. In March, one in Jacksonville, Florida, \$500,000. In May, a great fire in Troy, New York, destroyed \$3,000,000, and one in Brooklyn \$300,000. The aggregates of fires, for the year 1862, amount to nearly \$18,000,000, as shown in the following summary:

Date.	Place.	Loss.
1—Rochester.....		\$45,000
2—Richmond, Va. ....		65,000
2—Aquia Creek, Va. ....		20,000
5—Henderson, Ky. ....		20,000
5—Gardner, Mass. ....		75,000
5—Rochester.....		28,000
6—Philadelphia.....		75,000
6—Dover, N. H. ....		25,000
7—Pittsburg.....		125,000
7—Mendota, Ill. ....		45,000
7—Chicago.....		25,000
12—New York.....		60,000
12—McGregor, Iowa. ....		25,000
14—Boston.....		20,000
15—N. B'swick, N. J. ....		50,000
16—Williams'v's, N. Y. ....		20,000
17—West Farms, N. Y. ....		20,000
22—Plymouth, N. H. ....		20,000
25—New Orleans.....		150,000
25—New York.....		450,000
26—New York.....		200,000
27—Boston.....		100,000
28—Buffalo.....		22,000
28—Bath, N. Y. ....		40,000
29—Brooklyn.....		28,000
31—New York.....		20,000
31—Boston.....		80,000
<b>Total.....</b>		<b>\$1,868,000</b>

FEBRUARY.		
5—Philadelphia.....		\$30,000
10—Alexandria, Va. ....		38,000
12—Bowling Green, Ky.....		1,000,000
14—Cleveland, Ohio. ....		25,000
15—Cohoes, N. Y. ....		75,000
16—Cincinnati.....		24,000
22—New York.....		20,000
22—Augusta, Ga. ....		28,000
23—Jackson, Cal. ....		400,000
24—New Orleans.....		25,000
24—Boston.....		1,000,000
24—Fayetteville, Ark. ....		30,000
25—Richmond, Va. ....		35,000
26—Helena, Ark. ....		55,000
28—Elmira, N. Y. ....		100,000
<b>Total.....</b>		<b>\$2,918,000</b>

MARCH.		
1—Milwaukee.....		\$100,000
2—Bloomington, Ill. ....		35,000
4—Cleveland, Ohio. ....		125,000
5—Jackson, Mich. ....		80,000
5—Beverly, Mass. ....		100,000
7—New Orleans.....		45,000
9—Alexandria, Va. ....		25,000
10—Harrisburg, Pa. ....		27,000
11—Jacksonville, Fla. ....		500,000
18—Cohasset, Mass. ....		25,000
15—Portland, Me. ....		30,000
17—Blinghton, N. Y. ....		26,000
19—Marengo, Ill. ....		25,000
19—La Crosse, Wis. ....		125,000
22—Boston.....		40,000
22—Bethlehem, Pa. ....		70,000
24—Kansas City, Mo. ....		35,000
27—Clinton, N. Y. ....		25,000
30—New York.....		80,000
31—Norwich, Conn. ....		22,000
<b>Total.....</b>		<b>\$1,140,000</b>

APRIL.		
2—Detroit, Mich. ....		\$30,000
3—Milwaukee, Wis. ....		25,000
4—Washington, D.C. ....		50,000
7—Blue Lick Springs, Ky.....		55,000
7—Collinsville, Ill. ....		35,000
9—New York.....		75,000
10—Cherry Valley, N. Y. ....		200,000
14—Cooperst'n, N. Y. ....		60,000
30—Berlin, Wis. ....		80,000
<b>Total.....</b>		<b>\$620,000</b>

MAY.		
5—New York.....		\$35,000
7—Glasgow, Mo. ....		150,000
8—Sandusky, Ohio. ....		35,000
<b>Total.....</b>		<b>\$220,000</b>

JULY.		
1—Baltimore.....		\$35,000
2—Newark, N. J. ....		50,000
4—Chicago.....		35,000
5—Winona, Minn. ....		600,000
12—New York.....		40,000
21—Davenport, Iowa. ....		100,000
<b>Total.....</b>		<b>\$760,000</b>

AUGUST.		
2—Indiana, Pa. ....		\$25,000
5—Bloomfield, N. J. ....		20,000
6—New York.....		150,000
8—Philadelphia.....		75,000
11—Lenox, Mass. ....		30,000
12—Detroit, Mich. ....		75,000
12—N'r M'ynck, Pa. ....		30,000
12—Horsehd's, N. Y. ....		100,000
12—E. Gr'nw'ch, R.I. ....		200,000
15—St. Joseph, Mo. ....		60,000
17—Bear Valley, Cal. ....		50,000
19—Mariposa Co, Cal. ....		25,000
24—Philadelphia.....		25,000
27—St. Louis.....		100,000
28—Wrightsville, Pa. ....		75,000
28—New Orleans.....		60,000
<b>Total.....</b>		<b>\$1,120,000</b>

SEPTEMBER.		
1—Louisville, Ky. ....		\$50,000
5—New York.....		40,000
7—Fishkill L'g, N.Y. ....		20,000
8—Buffalo.....		100,000
8—Memphis.....		30,000
10—Belleville, N. J. ....		40,000
11—Grafton, Mass. ....		50,000
11—Saratoga, N. Y. ....		26,000
14—Baltimore.....		25,000
15—Rome, Ga. ....		75,000
19—Buffalo.....		300,000
20—West Troy, N. Y. ....		30,000
26—Charleston, S. C. ....		200,000
29—H. de Graco, Md. ....		25,000
<b>Total.....</b>		<b>\$1,021,000</b>

OCTOBER.		
1—Newark, N. J. ....		\$25,000
3—Winchester, Mass. ....		30,000
4—Fulton, N. Y. ....		250,000
6—Syracuse.....		150,000
8—Oil City, Pa. ....		100,000
8—Jamestown, N. Y. ....		25,000
10—Hawlandflat, Cal. ....		100,000
10—Troy, N. Y. ....		20,000
11—St. Paul, Minn. ....		22,000
11—Chambers'g, Pa. ....		200,000
12—H. de Graco, Md. ....		60,000
14—Newark, N. J. ....		20,000
22—Boston.....		50,000
23—Charles City, Iowa ....		30,000
24—Acton, Mass. ....		24,000
25—Houston, Texas. ....		60,000
26—Tranton, N. J. ....		100,000
27—St. Louis.....		150,000

Date.	Place.	Loss.	DECEMBER.		
30—	Erie, Pa.	75,000	Date.	Place.	Loss.
30—	Volcano, Cal.	25,000	1—	Chicago	\$40,000
Total.....		\$1,507,000	2—	Norwalk, Conn.	75,000
NOVEMBER.			4—	Morristown, N.J.	25,000
2—	Brooklyn	\$25,000	5—	Nashville, Tenn.	25,000
7—	York, Pa.	40,000	6—	Harper's Ferry	20,000
9—	Brooklyn	30,000	6—	Zellonopla, Pa.	25,000
10—	Near Hartford	20,000	6—	Lockhaven, Pa.	400,000
14—	Portland, Me.	25,000	8—	Peoria, Ill.	30,000
14—	New York	20,000	8—	Buffalo	20,000
15—	Batavia, N. Y.	20,000	18—	Cincinnati	25,000
15—	Memphis	30,000	15—	Peoria, Ill.	35,000
16—	New York	150,000	20—	Biddeford, Me.	20,000
17—	Paducah, Ky.	100,000	22—	Boston	24,000
20—	Chicago	40,000	25—	New York	65,000
22—	Poughkeepsie	32,000	30—	Washington City	30,000
26—	Worcester, Mass.	45,000	Total..... \$849,000		
Total.....		\$577,000			

RECAPITULATION.

MONTHS.	1862.		1861.	
	Fires.	Losses.	Fires.	Losses.
January	27	\$1,868,000	23	\$1,420,000
February	15	2,918,000	9	412,000
March	20	1,440,000	23	1,945,000
April	9	620,000	11	562,000
May	17	4,516,000	21	1,120,000
June	7	455,000	13	1,935,000
July	6	760,000	12	1,623,000
August	16	1,120,000	13	1,122,000
September	14	1,021,000	13	790,000
October	20	1,507,000	8	310,000
November	13	577,000	13	680,000
December	15	849,000	9	7,841,000
Total	179	\$17,640,000	138	\$18,020,000

There were thus 10 fires that destroyed \$7,600,000, an average of \$760,000, and 169 fires that destroyed an average of \$60,000 each. There was destroyed also, by fires of less than \$20,000 each, an aggregate of \$6,000,000. Making a total loss by fire of \$23,640,000 against \$24,020,000 last year. The aggregates of fires over \$20,000, distinguishing Northern and Southern States, were as follows:

YEARS.	Southern States.	Northern States.	Total.
1861	\$9,380,000	\$3,690,000	\$13,070,000
1862	1,925,000	16,715,000	17,640,000
Decrease	\$7,455,000		\$380,000
Increase		\$3,025,000	

Thus the losses at the North were nearly doubled during the year. These losses, however, do not include the ravages and devastation caused in the border States by the movement of armies, and which cannot be approximated until perhaps after years of peace, when numerous claims for damages shall have been passed upon. Some of these claims have already been presented to Congress, particularly in the case of the raid into Pennsylvania.

The insurance returns for the year indicate a considerable increase in fire risks. In Massachusetts these have been as follows:

COMPANIES.	Risks.	Losses.
In 29 Stock Companies	\$155,571,189 48	\$1,185,146 84
In 4 Mutual Fire and Marine	11,892,484 00	112,151 80
In 50 Mutual Fire	218,065,684 96	846,726 95
Total 1862	\$285,489,258 41	\$1,644,024 59
" 1861	355,287,806 37	1,340,059 97
" 1860	379,624,707 82	1,493,941 76

The returns of the fire business of the stock and mutual companies nearly approximate the ratio of premium to loss, or the average cost to the insured, as a body. The following is a comparison, in this point of view, of the last two years:

COMPANIES.	Premium.	Loss.	Average cost of each dollar of indemnity.
1861:			
Stock Companies	\$1,238,926 00	\$963,266 00	\$1 83
Mutual Fire Companies	454,446 00	849,265 00	1 80
Total	\$1,787,772 00	\$1,812,531 00	\$1 82
1862:			
Stock Companies	\$1,289,410 95	\$1,155,146 84	\$1 09
Mutual Fire Companies	402,783 49	846,726 95	1 15
Total	\$1,692,194 44	\$1,581,573 79	\$1 12

It is apparent from this that the companies, on the whole, suffered much more severely from fires in 1862 than in 1861. The losses were also less evenly distributed. There were not only a larger number of companies which paid more for losses than they received in premiums, but the net losses of the year were much larger to several companies than any experienced in the previous three years. The following table shows the number of stock companies that made net losses, putting expenses out of the account, in the past four years, the aggregate premium receipts, losses and net losses of said companies in each year, and the largest net loss of any company:

YEARS.	No. of companies.	Premiums.	Losses.	Aggregate net loss.	Largest net loss.
1859	8	\$74,005 67	\$81,714 09	\$7,708 42	\$6,642 40
1860	9	28,419 00	83,590 00	10,171 00	3,224 00
1861	3	168,789 29	184,660 99	15,871 70	9,480 18
1862	10	646,511 73	784,365 63	137,353 90	30,400 08

That ten out of thirty-four home stock companies should lose in the same year more than their premium receipts, to the extent of twenty-one per cent. of the same, is a startling fact. And it is none the less so that out of forty-eight foreign stock companies doing business in the Commonwealth, only four, and those all in New England, failed to receive premiums during the year in excess of their losses. These four have made an aggregate net loss of \$3,877, the largest being \$4,454.96. It is true, a large portion of the extraordinary loss of the year came from the single conflagration in Troy. But setting that aside, the table above given shows a tendency to misfortune of more than one year's standing.

The operations of the ninety-six New York fire companies, showing the fire and inland navigation risks, were for the year 1862 as follows:

Paid up capital of fire and inland navigation insurance companies of New York State	\$20,482,850 00
Total assets, December 31, 1862	27,327,990 37
Net cash premium taken in 1862	7,732,479 90
Total income	9,732,421 40
Losses paid in 1862, incurred before	360,906 43
Losses paid in and for 1862	4,315,500 29

Total loss incurred in 1862, as reported.....	\$4,744,046 47
Actual indebtedness, or present liability.....	783,978 07
Amount of reinsurance fund, or unearned premium.....	2,530,947 19
Total expenditure in 1862.....	8,026,042 46
Expenses of working the business, exclusive of taxes paid.....	2,163,065 89
Total liabilities, including estimate for reinsurance as returned, but excluding profit scrip.....	4,117,699 66
Net surplus (above capital) over liabilities and reinsurance.....	3,590,836 70
Amount of fire risks written in 1862.....	1,191,933,198 09
Amount of fire risks in force at end of 1862.....	891,620,865 58
Amount of inland navigation risks written in 1862.....	6,432,347 00
Amount in force at end of 1862.....	2,087,838 20
Average percentage of expenses on total income.....	23 23
Average percentage of expenses on net cash premium.....	27 96

The amount of risks taken by the companies in 1862 exceeded those of 1861 by \$362,644,325. The foreign companies doing business in New York, had risks in New York of \$121,726,767 fire and \$9,861,867 inland navigation. The amount of risks of the Massachusetts, New York, and of other States, exclusive of Massachusetts, doing business in New York, are as follows:

COMPANIES.	Inl'd navigation.	Fire.
Massachusetts.....		\$885,490,359 00
New York.....	\$6,432,347 00	1,191,933,198 09
Etna of Hartford.....	25,594,188 00	124,526,553 00
American, Providence.....	2,920,034 00	5,855,829 00
American, Philadelphia.....	854,880 00	12,384,631 00
Atlantic Fire and Marine, Providence.....	785,097 00	7,258,212 00
City Fire, New Haven.....		10,956,467 55
City Fire, Hartford.....	None.	11,984,130 05
Connecticut, Hartford.....	None.	6,317,133 88
Delaware Mutual Safety, Philadelphia.....	12,020,420 00	14,437,118 00
Franklin, Philadelphia.....		23,551,663 84
Hartford, Hartford.....		57,258,700 00
Home, New Haven.....	455,249 00	11,308,838 24
Hope, Providence.....		5,846,746 84
Insurance Co. of North America, Philadelphia.....	14,618,651 00	24,158,038 00
Jersey City, New Jersey.....	None.	4,080,774 66
Merchants, Providence.....	2,637,423 00	4,468,776 00
Merchants, Hartford.....	None.	10,593,024 00
North American, Hartford.....	None.	14,447,006 00
Norwich, Norwich.....	None.	6,642,802 66
Phoenix, Hartford.....	None.	84,007,039 00
Providence Washington, Providence.....	None.	13,923,605 00
Thames, Norwich.....	None.	8,075,064 00
Total, 1862.....	\$65,049,351 00	\$1,973,896,191 00

Such is the enormous amount of property at risk against fire in the companies in and about New York.

The insurance in New York companies is becoming more on the participation plan to the extent of three fourths of their profits.

They issue scrip to the policyholder for his share of said profits, and make no provision whatever for the redemption of this scrip except the excess of the fund of profits over a fixed sum, which may be \$500,000. When it comes to redemption, the oldest scrip takes precedence, and the fund is always subject to losses as much as the capital, and *before* the capital.

This principle works well. In Massachusetts the law requires the companies to divide the whole surplus cash premiums.

The directors divide money which should be kept. The premiums of new comers are taken to pay losses or dividends to the old ones; money is borrowed to do the same thing, thus still further anticipating the future business; and at last, when no more can be borrowed and debts can no longer be put off, resort is had to the notes, which can be collected with great difficulty. Among the Massachusetts companies there are ten that insure to the extent of \$15,185,994; to reinsure this amount would require \$91,205, and the whole available cash assets of the companies amount to \$16,480.

The mutual marine companies, though they issue scrip for profits, are allowed by law to retain the actual funds absolutely subject to be absorbed by future losses, and do not begin to redeem the scrip till the reserve fund exceeds a certain fixed amount; viz., it is at the option of the company to begin to redeem scrip after the fund reaches \$250,000, and it is imperative after it reaches \$500,000.

The past year has been one of unwonted activity in life insurance. The unusual number of men engaged in hazardous military and naval employments has apparently been accompanied by a desire to provide for families, and this desire has been met by the companies on appropriate terms. The demand so occasioned has induced the establishment of many new companies in different parts of the country; of them two have been started in New York. The following return (see Table on p. 533) shows the leading features of the companies doing business in New York during the year 1862.

The amount insured in 1862 was an average of \$2,492 on each policy, and equalled one third of the whole amount outstanding at the beginning of the year. The tendency has been to a great number of policies at a lower average sum, from the fact that, on military and naval risks, the amount insured by each policy has been more strictly limited than on other risks, whereby the companies have been able to extend the benefit of insurance to a greater number and still keep the aggregate within a prudent limit.

The reasons for receiving such applications were apparent. The members of the company and their families, wherever resident, have the same interest in the defence and perpetuation of our institutions as other citizens, and if the number of a family is taken to be five, on an average, this consideration would extend to about three hundred and twenty-five thousand individuals, and therefore, if the assumption of such risks would have a favorable influence, it was expedient to assume them on just terms and not to an excessive amount. The principal difficulty in the case was the want of satisfactory data on which to estimate the risk, since precedents applicable were wanting. But estimates were carefully made and such rates of premium adopted, subject to modifications for the varieties of risks, as would seem to put

LIFE INSURANCE COMPANIES IN NEW YORK.

NAME OF COMPANY.	Policies issued during the year.		In force at end of year.		Income during the year.			Expenditures during the year.			Total assets.	Per centage.		
	Number.	Amount.	Number.	Amount.	Premiums in cash.	Premiums not in cash.	Total.	Claims by death.	Dividends surrendered policies.	Expenses.		Total.	Fr. losses on in-coma.	Chains on in-coma.
Mutual Life	1,838	\$4,812,750	12,981	\$27,891,490	\$1,753,936	\$960,141	\$1,753,936	\$417,916	\$128,815	\$184,854	\$674,890	7.9	92.0	
New England Mutual	1,486	5,239,371	6,154	18,660,020	414,440	665,951	170,440	158,549	149,070	88,991	490,660	6.8	97.9	
New York Benefit, N. Y.	3,379	1,694,545	1,140	2,302,454	698,890	814,641	1,513,531	244,907	369,384	174,175	454,999	14.0	17.0	
Connecticut Mutual	1,771	6,094,575	1,715	25,181,192	791,414	453,950	1,245,364	949,940	315,874	103,049	773,074	16.0	14.1	
Manhattan	1,140	2,784,731	1,170	12,068,865	893,186	147,478	1,040,664	145,889	88,769	74,289	308,386	18.7	93.8	
United States	644	1,277,087	2,869	6,088,642	957,079	81,198	287,079	94,500	50,597	4,188	193,870	11.9	93.4	
National Vt.	170	1,246,700	1,869	6,988,175	73,744	18,094	70,943	58,787	4,671	9,291	40,694	94.4	93.9	
Knickerbocker	551	1,296,775	1,869	6,988,175	73,744	18,094	70,943	58,787	4,671	9,291	40,694	94.4	93.9	
Massachusetts Mutual	1,837	4,934,150	2,441	17,678,190	174,897	47,157	222,054	64,600	60,644	92,096	513,947	11.4	95.0	
Equitable	1,938	2,554,950	1,944	5,151,010	172,180	9,190	181,370	98,000	8,814	48,001	141,658	23.7	15.9	
Guardian	688	1,701,500	1,640	4,654,279	83,843	25,479	109,322	6,000	9,900	11,898	94,739	96.8	9.9	
Home	788	1,204,693	1,640	3,985,040	64,513	43,724	108,236	8,500	81,979	81,998	977,264	93.8	9.9	
Germania	1,860	1,318,800	1,018	2,150,770	58,395	...	58,395	7,175	3,905	90,536	960,885	93.8	13.0	
Washington	863	1,910,500	683	1,910,500	71,494	1,501	71,494	6,187	9,576	20,536	960,799	93.8	8.7	
North America	71	846,300	71	846,300	5,796	3,764	5,796	...	...	9,607	107,604	49.3	...	
Security	211	489,000	200	478,950	19,659	...	28,428	...	...	15,659	15,659	100.0	...	
<b>Total</b>	<b>17,422</b>	<b>\$48,480,569</b>	<b>65,080</b>	<b>\$150,870,688</b>	<b>\$5,798,945</b>	<b>\$1,568,767</b>	<b>\$7,367,712</b>	<b>\$1,691,887</b>	<b>\$1,195,731</b>	<b>\$570,960</b>	<b>\$8,538,714</b>	<b>\$88,873,797</b>	<b>...</b>	<b>...</b>

them upon a just footing, the amount to be limited in such manner that the companies should not be subject to a material shock, though the degree of risk should eventually prove to have been underestimated. So far as the rates adopted have been tested by experience, they seem to be fairly proportionate to the risks.

Some of the companies have paid about ten per cent of the aggregate losses on military and naval risks. The whole amount of losses is somewhat below that which ought, according to approved records of mortality, to have occurred, notwithstanding a much greater proportion of extra risks by land and sea subject to extra premium, than ordinarily comes into the tables. But the older companies are of course gradually approximating, from year to year, toward the point when, in consequence of the increased average ages of members, a greater ratio of mortality becomes due from the company.

As long as the mean of the aggregate ages of the whole number of members shall continue to increase, a greater ratio of losses to the whole number will be annually due to the law of mortality.

There are in Massachusetts 24 life companies doing business. These embrace few Massachusetts companies—but companies doing business in New York, except the Wisconsin Mutual, and some others. The returns of all these companies give the following results for 1862, as compared with former years:

YEARS	Number of policies.	Amount insured.	Net value.	Ratio of value to amount.
1890..	1	\$2,000 00	\$1,080 45	54.00
1894..	2	5,000 00	2,711 74	54.20
1895..	1	5,000 00	1,891 94	36.40
1897..	1	1,500 00	624 12	41.60
1898..	1	3,000 00	1,041 69	34.70
1899..	1	1,000 00	498 55	49.80
1840..	1	2,000 00	1,109 38	55.40
1843..	105	455,084 89	171,258 18	37.60
1844..	192	684,797 85	298,941 86	43.60
1845..	515	1,684,602 68	543,098 64	32.20
1846..	1,096	3,108,021 79	889,078 38	28.60
1847..	1,895	8,914,719 41	1,045,698 14	26.70
1848..	1,774	4,617,750 63	1,148,288 55	24.90
1849..	2,779	6,847,556 82	1,592,819 69	23.20
1850..	3,021	7,244,721 78	1,516,222 68	20.90
1851..	2,751	6,628,588 73	1,268,068 44	19.00
1852..	1,888	4,706,669 89	815,724 18	17.30
1853..	2,011	5,180,225 56	828,839 29	15.80
1854..	2,488	6,650,650 08	918,625 00	13.70
1855..	2,860	6,840,426 49	824,958 38	12.00
1856..	3,253	9,481,568 20	1,004,197 19	10.60
1857..	3,545	9,849,735 68	867,364 69	8.80
1858..	4,848	12,715,270 38	984,679 82	7.85
1859..	6,018	17,258,709 85	1,010,281 84	5.85
1860..	8,444	28,195,949 59	1,064,561 19	4.58
1861..	7,900	90,889,278 71	6,69,958 96	8.31
1862..	15,544	87,619,784 58	780,825 40	1.94
<b>Total.</b>	<b>71,425</b>	<b>\$189,494,295 88</b>	<b>\$18,007,867 91</b>	<b>9.51</b>

The number of policies outstanding, Nov. 1, 1862, it appears, was very nearly double the number that was outstanding at the same period in 1861, and the risks were increased by the sum of \$16,780,461.82. This fact indicates the very great impulse which the war has given to life insurance, and how carefully

many of those who have put their lives in peril in the country's service have protected the interests of those to whom those lives in some degree belong. In compliance with the request of the Massachusetts commissioner, 21 of the companies doing business made voluntary

returns of the number of policies altogether that had been issued by each, the whole amount insured, the receipts of premiums, the payments, losses, surrenders, &c., and expenses for all other purposes. The results were as follows:

COMPANIES.	Number of policies issued.	Amount insured.	Receipts (including premium notes, interest, &c.)	Disbursements.		Ratio of expenses, &c. to receipts.
				On policies (including losses, surrenders, and dividends paid).	For all other purposes (including losses on investments, expenses, &c.)	
<i>Home Companies.</i>						
New England.....	12,088	\$38,808,951	\$4,774,068	\$2,004,045	\$384,925	8.1
State Mutual.....	4,652	6,748,510	955,738	360,858	104,452	10.9
Berkshire.....	2,702	5,207,800	491,112	187,747	105,812	21.9
Massachusetts Mutual.....	5,893	10,766,945	894,215	372,285	146,835	16.4
<i>Foreign Companies.</i>						
Mutual Life, N. Y.....	26,150	78,992,454	13,788,967	4,492,546	1,880,896	9.6
Mutual Benefit, N. J.....	18,848	56,010,617	10,541,748	5,461,734	940,732	8.7
New York Life, N. Y.....	19,164	47,002,508	6,566,080	2,958,410	915,616	18.9
Connecticut Mutual, Conn.....	23,624	62,472,967	11,927,192	5,274,595	948,593	7.9
American Mutual, Conn.....	6,580	11,064,552	1,289,199	589,207	322,968	28.5
Union Mutual, Me.....	10,173	16,883,687	3,185,610	1,083,880	805,819	14.0
Manhattan, N. Y.....	8,700	24,804,621	2,799,010	1,200,091	410,069	14.6
National, Vt.....	3,178	4,823,847	589,181	165,994	128,688	21.2
Phoenix Mutual, Conn.....	6,415	8,674,056	681,545	202,221	129,574	24.4
Charter Oak, Conn.....	10,188	16,210,000	1,813,816	540,586	841,281	18.8
Knickerbocker, N. Y.....	2,955	7,832,782	480,285	105,851	157,598	36.6
Wisconsin Mutual.....	2,082	3,281,800	156,464	17,041	85,728	22.9
Equitable, N. Y.....	2,800	7,755,100	891,715	54,216	117,781	30.0
Guardian, N. Y.....	1,475	3,110,872	119,074	27,716	60,818	50.6
Washington, N. Y.....	915	2,596,900	127,648	11,799	68,580	50.5
Home, N. Y.....	2,188	4,886,450	283,731	84,681	72,691	30.4
Germania, N. Y.....	949	2,131,600	97,805	8,588	50,845	51.5
<b>Total.....</b>	<b>175,608</b>	<b>\$409,565,919</b>	<b>\$60,936,768</b>	<b>\$25,109,386</b>	<b>\$7,098,611</b>	<b>11.6</b>

Of this vast amount, \$409,565,919, that has been insured, it appears that nearly one half is outstanding, and that \$25,000,000 has been paid. The greater part have apparently discontinued through the cessation of the necessity for insuring, which may to a greater or less extent be the case in times of prosperity; there were also, no doubt, numbers who ceased to pay a premium through inability, and others through growing disregard of its utility. It is apparent, however, that within 20 years over 60 million dollars have been paid over to insurance companies from prudential motives, and these 60 millions are savings of earned capital of a nature similar to the deposits in savings banks. The deposits and the life premiums together make an amount equal to 250 millions thus saved within 20 years.

IOWA, one of the northwestern States, bounded on the east by the Mississippi river, contained in 1860 a population of 674,918, being an increase of 482,699 since 1850. The number of white males was 358,900, do. females 319,879.

The mortality in the State during the year ending May 31, 1860, was 7,260. The most fatal diseases were consumption, croup, fevers, and pneumonia.

The value of some items of the productive industry of the State during the year ending June 1, 1860, was as follows: iron founding, \$187,435; lead, \$160,500; coal, \$6,500; lumber, \$2,378,529; flour and meal, \$6,950,949; spirituous liquors, 883,820 galls.; malt liquors, 35,588 bbls.; woollen goods, \$167,960; leather,

\$81,760; boots and shoes, \$325,296; furniture, \$157,491. Total value of industrial products, \$14,900,000.

The value of real and personal property was \$247,388,265; lands improved, 3,780,253 acres; do. unimproved, 5,649,136 acres; cash value of farms, \$118,741,405.

Crops produced in 1861, according to the report of the superintendent of agriculture, were as follows: wheat, 18,350,000 bushels, valued at \$7,200,000; corn, 60,000,000 bu., value, \$7,200,000; oats, 10,000,000 bu., value, \$1,500,000; potatoes, 3,000,000 bu., value, \$750,000; hay, 800,000 tons, value, \$1,200,000; orchard products, value, \$300,000; butter, 15,000,000 pounds, value, \$1,200,000; cheese, 3,000,000 pounds, value, \$240,000; cattle 200,000; wool, 50,000 pounds; domestic manufactures, \$800,000; total of all products, \$33,251,000. The number of miles of railroad in this State, in 1860, was 679; cost of construction, \$19,494,633.

The governor of the State is Samuel J. Kirkwood, whose term of office expires Jan. 1, 1864. The secretary of State is James Wright. The judiciary consists of three supreme court judges, elected by the people for six years, and eleven district judges. The funded debt of the State is \$1,192,295. There is one State bank with a capital of \$720,800, and fifteen branches. Legislature meets biennially, and consists of forty-six senators, and ninety-three members of the house. The former are elected for four years, and the latter for two years. This body was twice in session

during 1862. The first session was at the beginning of the year, and the second in September. They were devoted to providing for the unusual circumstances of war in which the State was called to take a part, and to the ordinary objects of local legislation. Some of these objects were to make provision for sick and wounded soldiers, offer inducements to volunteers to enlist; a modification of the election laws, that volunteers might vote when absent; and increasing the resources of the executive department.

The State election for members of Congress and half the Senate and the members of the House of the State Legislature, took place on the second Tuesday of November. The people were divided into two parties, the republican and the democratic. The platform of the republican party was similar in its general principles to that adopted by the same party in Illinois, on page 519, to which reference is here made. The platform of the democratic party was similar to that adopted by the same party in the States of Ohio and Pennsylvania, to which reference is made. The offices to be filled at this election were secretary of State, auditor of State, treasurer, attorney-general, and register of the land office, and six members of Congress. The vote of the citizens was as follows:

For the republican candidate for Secretary of State..	66,014
For the democratic candidate for Secretary of State..	50,589
Majority for the former.....	15,115

The soldiers in the several regiments which had gone from the State, were also allowed to vote, with the following result:

For the republican candidate for Secretary of State..	14,874
For the democratic candidate for Secretary of State..	4,116
Republican majority.....	10,759

The votes for the other State officers were as follows:

	Republican.			Democratic.			Majority.
	Citi- zens.	Sol- diers.	Total.	Citi- zens.	Sol- diers.	Total.	
Auditor...	51,126	14,969	66,095	46,674	4,112	50,786	15,309
Treasurer...	51,119	14,885	66,004	46,694	4,145	50,839	15,165
Register...	51,147	14,858	66,005	46,645	4,118	50,763	15,242
Attorney..	51,040	14,830	65,870	46,647	4,186	50,833	15,137

The candidates of the republican party for Congress were all chosen by the following vote:

	Republican.	Democratic.
1st district.....	12,705	10,486
2d ".....	12,488	8,980
3d ".....	12,112	8,452
4th ".....	12,900	11,529
5th ".....	10,806	7,346
6th* ".....	5,886	2,755

At the election for governor in 1861, the republican majority was 16,608; do. at the presidential election in 1860, 15,298.

The republicans obtained a large majority in both branches of the Legislature at the last election in 1861, when that body stood as follows:

	Republican.	Democratic.
Senate.....	83	14
House.....	59	88

\* Incomplete.

The number of regiments of infantry from the State in the field near the close of the year was thirty-nine; do. of cavalry four, and three batteries. In addition, there are soldiers from the State in the 1st Nebraska, 5th Kansas, 7th, 10th, 21st, and 25th Missouri.

ITALY, a limited monarchy of Southern Europe, embracing the whole of the Italian peninsula except a small part (4,502 square miles) of the States of the Church and the Austrian province of Venetia, formerly the Republic of Venice. King Victor Emanuel II, born 1820, acceded to the throne of Sardinia in 1849, and was crowned King of Italy, 1862. Area of the kingdom, 95,942 square miles. Population, 1862, 22,430,000. The ordinary revenues of the kingdom for the year ending Jan. 1, 1862, were \$97,756,440; the expenditures for all purposes, \$155,996,260. The national debt at the same date was \$536,032,422.

The record of the condition of Italy in the "Annual Cyclopædia" for 1861, leaves it at the critical moment when the death of its great statesman, Cavour, had plunged the nation in sorrow. The people of Italy, as well as its king, felt that Cavour, and he only, was capable of solving the difficulties of their situation; of coping, by the force of his genius and the power of his will, with the shrewd and selfish policy of Napoleon III; of paralyzing the efforts of the weak but mischievous Bourbon, whom Garibaldi had relieved of his crown, to overthrow the new government; of overcoming the sullen obstinacy of the Pope, and of restraining the fiery impatience of the revolutionary chief, Garibaldi.

When, by a sudden stroke, they were deprived of this wise and patriotic statesman, the king and the nation sought at once for some man whose patriotism, intellectual ability, and personal influence were such that he could, at this critical juncture, assume the responsibilities and carry out the policy of the deceased minister. One name, and one only, seems to have suggested itself to the minds of the nation, that of the Baron Ricasoli, not as the equal in intellectual power of the great minister, but as a man of pure patriotism, of inflexible integrity, of personal sympathy with and devotion to Cavour's views, and of sufficient ability and influence to push to their consummation the purposes and plans of the deceased minister. To him, accordingly, the premiership was at once tendered, and he accepted it with the avowed purpose of being governed by the views and endeavoring to attain the objects which Cavour had sought. For this purpose he made slight and only absolutely necessary changes in the personnel of the cabinet, and promoted the measures which Cavour had initiated.

But there were numerous obstacles in the way of his success on which he had not counted. Though irreproachable in the integrity and purity of his character, and intensely patriotic, the Baron Ricasoli's manners were somewhat haughty, and he possessed little of that power

of personal fascination which had given Cavour such thorough control over those with whom he came in contact. He utterly abhorred everything like bribery and corruption, and the indolence of the king, which led him to yield to the solicitations of the unworthy to avoid trouble, drew down upon him more than once the stern remonstrances of the honest and upright minister, and led to a want of that personal sympathy between them so indispensable to the successful administration of the government. His colleagues, too, complained of his haughty manners, and one of them, M. Minghetti, Minister of the Interior, resigned in September, 1861.

The French emperor found the premier as incapable of being moulded to his purposes as his predecessor had been, but he feared him less than Cavour, and sought only the means of covertly securing his overthrow. These were, unhappily, not wanting. Among the prominent political leaders of Italy, was the commendator Urban Ratazzi, a citizen of Alexandria in Piedmont, educated by the Jesuits at Turin, and given to intrigue. This man, who possessed considerable talent in political affairs, and the specious and adroit manners which enabled him to force his way into public notice, was a member of the first Sardinian Parliament in 1848, and became a member of Gioberti's cabinet the same year, and having by an act of treason to that statesman, who had intrusted him with his plans, procured the overthrow of the cabinet of which he was a member, succeeded in obtaining the position of premier in the new cabinet which succeeded, and as such, urged the unfortunate Charles Albert on to the resumption of those hostilities which culminated in the fatal battle of Novara. Driven from power by this catastrophe, Ratazzi took his place in the opposition, watching for another opportunity of grasping the reins of government. In 1852, Cavour, who knew how to use such men, procured his election to the presidency of the Lower House of the Parliament, and before the close of the same year, becoming himself premier, gave him a subordinate position in the cabinet. He remained in this cabinet several years, being finally promoted to the Home Secretaryship, but was eventually driven to resign, from his suspected complicity with men who were seeking to overthrow the Piedmontese Government. Cavour again procured his election to the presidency of the Lower House, though he knew that he had been intriguing to oust him from the premiership. When, after the peace of Villa Franca, Cavour resigned his position as incompatible with honor, after the pledges made to the Italian people had been violated by their ally, the French emperor, Ratazzi, who had assiduously courted the good will of Napoleon III, pushed himself forward for the premiership and was appointed to it by the king. His whole career (of six months) was one of obsequious servility to French dicta-

tion, and of officious meddling with the affairs of Lombardy, while all the overtures for union with Sardinia and Tuscany, Modena, Parma and the Romagna were repelled.

At last this cabinet fell, pushed from power by the overwhelming conviction of its utter incapacity, and the vigorous hand of Cavour again assumed the reins of government, only to be relinquished at his death. It would have seemed that, after thrice being compelled to resign in disgrace, Ratazzi would not have aspired again to power; but such was his brazen assurance that he again made himself prominent. He had been reelected president of the Lower House of Parliament, and while professing to sustain the administration of Ricasoli, his whole thoughts were bent upon its overthrow. For this purpose he ingratiated himself into the favor of the indolent king, and craftily sought to bring about a feud between him and his minister; during the vacation of Parliament he made a journey to Paris, causing his creatures to give out that he was sent on a secret mission from Victor Emanuel to the French emperor; while in Paris, he assumed the airs, and received the honors due to an envoy extraordinary; Napoleon III understood his man, and so far lent himself to his purposes, as to manœuvre for his succession to the premiership. On his return to Turin, he sought the confidence of the radical party (the followers of Garibaldi, who were disaffected by what they regarded as the slowness of Ricasoli in securing the possession of Rome as the capital). Ratazzi professed the utmost sympathy for Garibaldi, and an earnest desire to promote his plans, and finally pledged himself if the Ricasoli Cabinet was overthrown, and he placed at the head of the new one, to put two of Garibaldi's friends in the cabinet, to appoint others prefects at such points as he should request, and to aid the revolutionary chief in his attack on Rome or Austria with money and arms, and permit the raising of corps of volunteers for that purpose throughout Italy. To the French emperor and the French party he promised to prevent any movement to seize upon Rome, and offered to pledge his cabinet in advance to take no measures for the acquisition of that city, which, he said, Italy did not need. To still another party, small in numbers, but possessing considerable influence, the party of the old Piedmontese aristocracy, he avowed his hostility to territorial acquisition, and his determination to maintain a policy of centralization by which the institutions, laws, and administration of the newly acquired State should be made to conform to the Piedmontese pattern, and their beloved Turin should become to Italy what Paris was to France. He had not neglected to subsidize the press in his favor, not at his own cost, but at the king's, and more than one prominent journal was filled with his praises.

It was in December, 1861, when all his plans for Ricasoli's overthrow had been laid,

that that statesman offered to him the portfolio of the Interior, which had been vacant since September. The crafty politician had no intention of accepting it, but he parleyed for some time, and at first gave encouragement that he would comply with the premier's offer, but finally with apparent reluctance, declined it, and Ricasoli, following Cavour's example, added it to his other duties. The plot was fast ripening; and Ratazzi, sitting with seeming impartiality as president of the chamber of deputies, prompted first one and then another of his allies to attack the ministry, while he himself avoided any public committal. Meantime he had succeeded in corrupting Sigor Cordova, one of Ricasoli's cabinet, whom he had promised, for his treachery, a place in his own cabinet. On the 2d of March, 1862, the king, who, to his subsequent regret, had been completely under the influence of Ratazzi and his followers, sent a communication to Baron Ricasoli, which led him to convene his cabinet and submit to them the propriety of resigning office. The resignation was unanimously agreed upon, Cordova being the loudest in his consent, and was tendered to the king the same day, and at first declined, but afterward accepted, and when, on the morning of March 3, the ministers waited upon the king to surrender the seals of office, they found Cordova closeted with the monarch, and arranging for his retention in the cabinet. Ratazzi fulfilled his promise to Garibaldi by giving place to Persano and Despretis, professed friends of Garibaldi, in his cabinet, and subsequently appointed other of his friends as prefects in Sicily and Naples. Of the other members of the cabinet three belonged to the French party, and two were of the old Piedmontese aristocracy. On the 7th of March, Ratazzi, having completed his cabinet, announced to the parliament that "the principles of his government would be a largely conciliatory spirit toward all true Italians, without regard to personal differences, the removing all dualism between government and nation, a policy of non-isolation from foreign powers, economical management of the finances, and a cordial alliance with France, whereby that completion of Italy would be best achieved, which as the wish of every patriot, was naturally the cherished wish of the ministers."

It was inevitable that a cabinet constituted from such discordant materials, and hampered by pledges to parties so diametrically opposed to each other, would very soon fall into difficulties.

It was with difficulty, and only from a strong sense of duty on the part of the patriotic majority in the parliament that the Ratazzi administration managed to live through the first month of its existence. Baron Ricasoli withdrew into the country, and his friends, desirous of avoiding embarrassment to the king, voted down as inopportune, a motion of direct censure, offered only 12 days after the cabinet

was announced. Ratazzi found himself compelled to intimate to Cordova and Mancini, two of the members of the cabinet, the necessity of their resigning, and to supply their places with men more acceptable to the parliament.

Garibaldi had previously sought to hasten the redemption of Italy from Austrian and Papal sway by an appeal to the Hungarians to rise against their old oppressors, and had, after considerable forbearance on the part of Ricasoli, been warned that if an expedition which he had planned to attack Austria through Hungary, were not given up, the Government would be compelled to arrest it by force. The ex-dictator had submitted reluctantly, and with a feeling of hostility to Ricasoli, which Ratazzi had carefully stimulated.

On the 12th of April parliament was adjourned to the 3d of June, and soon after the premier and the king visited Naples, accompanied by Garibaldi, who with their apparent approval was already organizing his schemes, and enlisting his bands of volunteers. In Lombardy he had, in May, gathered a considerable body of riflemen, and made some feints of attacking the Tyrol. Probably at the French emperor's instigation, Ratazzi, on the 12th-15th of May ordered the arrest of several of Garibaldi's confidential officers, and a large number of the men he had enlisted, and committed them to prison, sequestering their arms, all the while professing the greatest regard and respect for Garibaldi himself, who he affected to believe was not cognizant of their doings. Garibaldi, furious at this unexpected act, avowed his responsibility for their conduct, denounced the arrest, and demanded their release, but could get no reply from the Government. On the 16th of May a collision occurred at Brescia between a mob who endeavored to set the arrested men free, and the soldiers, in which several persons were killed. The Government soon after published a circular, declaring a direct contradiction to his own asseverations that they had good grounds for believing that Garibaldi had had no participation in the enterprises for which these men had been arrested, and that his name had been improperly used. Meantime the crafty minister had prevailed upon the ex-dictator to return to Caprera, and on the reassembling of parliament took to himself great credit for having suppressed an insurrection which bid fair to disturb the public peace, reading a professed letter from Garibaldi to sustain his position. He was destined, however, to receive, from Crispi, a deputy who was a friend of Garibaldi, a castigation which would have driven any other man to tender his resignation.

Garibaldi, meantime, was projecting new schemes, and was still duped by the promises and manoeuvres of the wily premier. He had gone to Palermo, and in the presence, and with the sanction of prefects whom Ratazzi had appointed, broached his plan for an expedition to attack Rome from Sicily. He roused the



enthusiasm of the Sicilians by his proclamations and, coöperating with Mazzini, commenced organizing a small army of invasion, believing that the measure had the full sympathy of the Government, which indeed had furnished it with means and arms. Napoleon III began to protest, and Garibaldi and Mazzini denounced the emperor without stint. Thus passed the month of July without remonstrance from the Italian Government. At length, on the 3d of August, Victor Emanuel issued a proclamation to the Italian people warning them to take no part in any enterprise such as was proposed, as it would be regarded as revolt and civil war, and pledging himself to secure for them eventually the possession of Rome. This proclamation under Ratazzi's secret explanations Garibaldi regarded as a ruse, and went on with his preparations. The Emperor sent war vessels to blockade the Sicilian coast to prevent his passage to the main land, and Ratazzi finally sent Gen. Cugia with orders to prevent the ex-dictator from marching toward Rome, but not to interfere with him if he wished to go anywhere else. Garibaldi meantime had moved forward to Catania on the 18th of August, adopting as his watchword, "Rome or Death." On the 24th and 25th of the same month, he succeeded in crossing the strait near Cape Spartivento, having had a slight skirmish with some Italian troops, in which he lost a few prisoners. He had, at the time of crossing, a force of about 2,800 men. About 500 whom he had left at Catania were taken prisoners on the 26th. It was no part of his purpose to come into conflict with Italian troops, and he accordingly passed by mountain routes from Mileto and Reggio toward Aspromonte, encountering, on the 27th, a small force, and losing 42 of his men as prisoners. On the 29th, he occupied a strong position at Aspromonte, where he was attacked by Col. Pallavicini. He directed his men not to fire at Pallavicini's troops, but the royal commander was not so forbearing, and 12 of the Garibaldians were killed, 200 wounded, among whom were Garibaldi himself, and his son, Menotti; 2,000 were taken prisoners, and conveyed to Spezzia. Garibaldi asked to be put on board an English ship, but Ratazzi refused to grant this, and he was kept as a prisoner. His wounds were painful, and one of them (a ball in the foot) was deemed dangerous. The knowledge of his being wounded and taken prisoner produced great excitement throughout Europe: an eminent English surgeon went on to Spezzia to attend him, and his expenses were defrayed by a public subscription. After some

months of suffering the ball was extracted, and his recovery, though tedious, is probable. The Italian Government found itself greatly embarrassed with the prisoners thus taken. The revolutionary chief, who had given Victor Emanuel the kingdom of the Sicilies, could not be treated as a common prisoner, even though taken in arms against his king; nor was it to be believed that he was at heart disloyal to that king; he was rather the dupe of the prime minister, and had believed himself really doing the king service. From all quarters came appeals for an amnesty for him and his followers. At the wedding of the second daughter of Victor Emanuel and the young King of Portugal, on the 27th of September, both the bride and bridegroom, and Prince Napoleon and the Princess Clotilde (the eldest daughter of the king) added their prayers for the amnesty, which was granted on the 5th of October.

The arrest of Garibaldi's expedition intensified rather than checked the feeling of the whole Italian nation that Rome must become their capital. This feeling found vent in the circular of the minister of foreign affairs, Signor Durando, to the representatives of Italy at foreign courts, on the 10th of September, in which he said that Garibaldi's watchword ("Rome or Death") was but the expression of a national necessity, more imperious now than ever. It found a still stronger expression at the reassembling of the Parliament, when the Chamber of Deputies adopted an address to the king, in which, after thanking him for the amnesty decreed to Garibaldi and his followers, they proceeded to say, "the time for action for the acquisition of Rome is delayed; for the present we will strengthen our finances by an active industry; we will increase our army to 400,000 men, and then, sire, with you at its head, we will see who will withhold Rome from us!"

The Ratazzi cabinet fell in November, at the reassembling of Parliament, under the withering scorn of the nation's representatives; having sunk so low in reputation that no respectable minority could be found to support it. The premier, in his intense desire for a prolongation of his power, even for a few weeks, begged the king to prorogue the Parliament so that a new ministry might not be confirmed, but Victor Emanuel, to his credit, firmly refused. The new cabinet consists of Signor Farini, premier; Peruzzi, minister of the interior; Mughelti, minister of finance; Amari, public instruction; and Manna, commerce. It is said to be a cabinet of great ability and high character.

## J

**JOHNSTON, ALBERT SYDNEY**, a general in the Confederate service, born in Mason county, Kentucky, in 1803, was killed at the battle of Shiloh, April, 6, 1862. He graduated at West

Point in 1826, as lieutenant in the 6th infantry, served in the Black Hawk war, and in 1836 entered the Texan army as a private soldier. After several promotions, he succeeded Gen.

Felix Houston in the chief command, and was involved in a duel with him in consequence. In 1838, he was appointed secretary of war, and, the following year, engaged in a successful expedition against the Cherokees. In 1840, he retired to private life for a time, in Brazoria county, Texas; but in 1846, at the solicitation of General Taylor, he assumed the command of a volunteer Texan regiment against the Mexicans. At the siege of Monterey, he served as inspector-general, and won himself much distinction. In October, 1849, he received from President Taylor the appointment of paymaster of the army, with the rank of major. In 1857, he conducted the expedition against the Mormons, and commanded the dis-

trict of Utah, with the brevet rank of brigadier-general, until 1860, when he was removed to the command of the Pacific department, and stationed at San Francisco. His sympathies being upon the side of the Southern Confederacy, he was making arrangements to deliver the State of California to the Confederacy when he was unexpectedly superseded in his command, by General E. V. Sumner, before his plans were completed. Upon his return to the East he was placed in an important command, and, at the battle of Shiloh, was commander-in-chief of the Confederate army of the West, and, in the first day of that sanguinary fight, when encouraging and urging forward his troops, was mortally wounded.

## K

**KANSAS**, a central State of the American Union, admitted to the Union in 1861. Area, 80,000 square miles; population in 1860, 107,206. The local administration of the State in 1862 was involved in some trouble; Gov. Robinson, elected in 1860, before the admission of the State into the Union, claiming to hold over, on the ground that the term for which he was elected had not expired, while, at an election held under the State constitution, George A. Crawford was elected by 5,429 votes. The matter was finally settled by the courts, which decided that Gov. Robinson's claim was just. In the autumn of 1862 an election for State officers, Legislature and members of Congress, was held, and Thomas Carney, the republican candidate, was elected governor for two years from Jan. 1st, 1863, receiving 4,545 majority. W. W. H. Lawrence, also a republican, was elected secretary of State for the same term. A. C. Welder, republican, was elected representative in Congress, receiving 4,998 majority over the democratic candidate. The Legislature was about four fifths republican.

Having had long experience in border warfare, during her period of territorial pupilage, Kansas had a large military force, in proportion to her population, ready to enter the national service at the commencement of the war. She had sent on the 1st of Dec., 1862, over 14,000 men into the field, a larger percentage of the whole population than any other State has contributed.

In the spring of 1862 an expedition was fitted out in the State to go south, through the Indian Territory, to reduce the Indian tribes which had joined the Confederacy to subjection, and repossess the U. S. forts, Gibson, Arbuckle, Washita, and Cobb, of which the Confederates had taken possession. The expedition consisted of about 5,000 troops, of which 2,000 were whites and 3,000 loyal In-

dians. The expedition was unfortunate in its commanders at first: Gen. Blunt having assigned the command to Col. Charles Doubleday, of the Second Ohio cavalry; but, from some political influences, he was removed, and Col. Wm. Weir, of Kansas, substituted. Col. Weir's management was so inefficient and ruinous that Col. Salmon, of the 9th Wisconsin regiment, who commanded one of the brigades, deemed it necessary to arrest him on the charge of insanity. Under Col. Salmon's management the expedition took possession of the Indian Territory, arrested John Ross, the principal Cherokee chief, as being of doubtful sentiment toward the United States, and received professions of loyalty from about two thirds of the Cherokees and Creeks. The Choctaws they found mostly on the side of the Confederacy. Large numbers of the slaves of the Indians enlisted in the army of the expedition as "Woolly-headed Indians." The expedition had subdued and held the country north of the Arkansas river before the 25th of July, and Gen. Blunt, on the 8th of August, taking command in person, routed the Confederate force at Maysville, in the N. W. corner of Arkansas, on the 22d of Oct.; on the 28th and 29th of Nov. he again met and defeated, with heavy loss, the Confederate forces under Gen. Marmaduke, at Cane Hill, Ark.; on the 7th of Dec. he defeated and scattered a greatly superior force (28,000) of the Confederates under Gen. Hindman, at Prairie Grove, Ark., his loss being about 1,000, and that of the Confederates 1,500, the Confederates retreating in the night, abandoning their dead and wounded; and on the 27th and 28th of Dec. Gens. Herron and Blunt defeated two regiments of Confederate cavalry at Dupping Spring, and captured Van Buren, a strong fortress on the Arkansas river, taking one hundred and twenty prisoners, and four steamboats laden with stores.

KEARNEY, Maj.-Gen. PHILIP, an officer of volunteers in the United States army, born in the city of New York, June 2, 1815, was killed at the battle of Chantilly, Va., September 1, 1862. He was of Irish descent, his great-grandfather having settled in Monmouth county, New Jersey, in 1716, and was a nephew of Gen. Stephen Watts Kearney. He studied law, but having a decided taste for military life, at the age of 22 accepted the commission of second lieutenant in the United States 1st dragoons, commanded by his uncle, and soon after was sent to Europe by the Government to study and report upon the French cavalry tactics. To accomplish this object he entered the military school at Saumur, in France, and from thence went to Africa, where he joined the First Chasseurs d'Afrique, as a volunteer. By his daring exploits he attracted the attention of the French army, and was presented with the Cross of the Legion of Honor. In 1840 he returned home and received the appointment of aide-de-camp to Gen. Macomb, and the following year was aide-de-camp to Gen. Scott, serving in that capacity until 1844. In 1846 he became captain of a company of dragoons, and from his private means provided for his men equipments and horses, and his corps formed the escort of Gen. Scott when he made his entrance into Vera Cruz. For gallant and meritorious conduct at the battles of Contreras and Churubusco he was breveted major. While making a brilliant charge upon a battery at the St. Antonio gate of the capital, he lost his left arm. He had ordered the charge, but his men beginning to waver under a terrific fire, he dashed forward, and the troops electrified by his example followed, and slaughtered the Mexicans at their guns. After the Mexican war he was sent to California, and commanded an expedition against the Indians of the Columbia river, displaying during the campaign such tact and courage as won him the praise of the best military judges. In 1851 he resigned his commission, and returning to Europe, devoted several years to military studies. During the Italian campaign of 1859, Major Kearney served as volunteer aid to Gen. Morris, a distinguished officer in the French army, and upon its conclusion he received from the Emperor Napoleon a second Cross of the Legion of Honor. He was residing in Paris when the present war broke out in 1861, and hastened home to offer his services to his country, and after some delay was appointed brigadier-general of volunteers, and placed in command of the New Jersey troops, and afterward of United States volunteers. He distinguished himself at Yorktown, Williamsburg, Fair Oaks, White Oak Swamp, the Cross Roads, and Malvern Hills, and subsequently near Washington, under Gen. Pope. He was commissioned major-general July 4, 1862. As a disciplinarian Gen. Kearney was second to none in the army, and his troops were enthusiastic in their admiration of his military ability.

KENTUCKY, the garden of the United States in fertility and productiveness, had, in 1860, a population of 919,547 whites, 10,684 free colored, and 225,488 slaves, which was an increase of 278,279 during the preceding ten years. The number of white males was 474,193; do. females, 445,291.

The mortality in the State during the year ending May 31, 1860, was 16,467. The most fatal diseases were consumption, croup, typhoid fever, pneumonia, and scarlatina.

Of iron, there were produced 23,862 tons of pig, and 6,200 tons of bar. The product of iron founding was valued at \$757,400; coal mined, 6,782,000 bushels; lumber, \$2,200,674; value of flour and meal, \$5,084,745; spirituous liquors distilled, \$3,247,208 gallons; do. malt, 74,850 barrels; cotton goods manufactured, \$167,500; do. woollen, \$1,128,882; leather, \$701,555; boots and shoes, \$685,783; furniture, \$256,046; soap and candles, \$486,900; value of products of industry, \$36,310,000. The value of real and personal estate was \$666,043,112; lands improved, 7,644,217 acres; do. unimproved, 11,519,059 acres; and cash value of farms, \$291,496,955.

Some of the productions of agriculture were as follows: horses, 355,754; asses and mules, 117,635; milch cows, 269,215; working oxen, 108,999; other cattle, 457,845; sheep, 988,990; swine, 2,380,595; value of live stock, \$61,868,287; wheat, 7,394,811 bushels; rye, 1,055,262 bushels; corn, 64,043,638 bushels; oats, 4,617,029 bushels; rice, 24,407 pounds; tobacco, 108,102,488 pounds; cotton, 4,092 bales of 400 pounds each; wool, 2,325,124 pounds; peas and beans, 288,349 bushels; potatoes (Irish), 1,756,532 bushels; do. sweet, 1,057,558 bushels; barley, 1,057,558 bushels; hemp (dew rotted) 38,044 tons; do. water rotted, 2,026 tons; do. other, 4,344 tons; flax, 728,284 pounds; maple sugar, 880,941 pounds; honey, 1,768,692 pounds; value of home-made manufactures, \$2,095,578; slaughtered animals, \$11,640,740; miles of railroad, 569; cost of construction, \$19,068,477.

The position of Kentucky relative to the affairs of the Union, on the whole, remained unchanged during the year. Her determination was to sustain the Federal Government in all its measures designed for an honest restoration of the Union without interference with the institutions of the States. A very considerable portion of her citizens, however, sympathized with the Government of the Confederate States, and made valuable contributions to its aid. The governor, in his message to the Legislature, at its session, in the beginning of the year, thus describes the condition of the people:

There is no disguising the fact that the people are suffering seriously in every quarter of the State for the want of means to meet their engagements. Trade is stopped in a great measure, and even what produce finds its way to market is sold at ruinous sacrifices. In regions over which the contending armies have passed large amounts of property have been taken or destroyed, the country has been made desolate, and

large numbers of the people who were contented, comfortable, and independent, are suffering for the necessities of life; their fences have been destroyed, their stock and provisions taken, so that many cannot make a crop this year; add to this, that many persons have been frightened or dragged from their homes and suffering families. The laws are silent, or cannot be executed. Universal gloom and distress pervade these regions. Families are divided and broken up, and each has its wrongs or its woes to relate. Starvation stares many in the face. In other and more highly favored districts no property of any description can be sold at one third of its former value. The people are much in debt. They would gladly pay if their property would bring anything like a reasonable price; but owing to the great reduction in the circulation of the banks, from thirteen to five millions of dollars within a year or two; owing to the enormous war debt which must be met by an increase of taxation, the destruction of property and of confidence, the withdrawal of funds by capitalists, and the consequent fall in prices, the indebtedness of our people, and the opening of the courts, bankruptcy, and ruin stare them in the face unless they get relief.

There was not a cordial coöperation between the governor and the majority of the Legislature. Several bills, passed by the Legislature, were vetoed by him, such as an act to disfranchise all citizens who entered the Confederate service; another requiring all clergymen to take an oath to sustain the Constitution of the United States before performing the marriage ceremony, &c. These things, however, were soon lost sight of by the movements of the Federal troops, which engrossed attention. Kentucky was not only completely under their control, but the Confederate forces were driven beyond her limits. Even at this time the State had contributed more than its quota to the Federal army, and there was no military organization of the State but entirely acquiesced in this contribution.

In August an extra session of the Legislature was held on a call by Gov. Magoffin. The necessity of the session was thus explained by him:

Most cheerfully have I convened you in extraordinary session, upon the earnest appeal of the Speaker of the House of Representatives, and other distinguished members of both branches of the Legislature, who thought themselves justified, by the alarming condition of the State, in taking the responsibility of making the request in behalf of the absent members of the General Assembly. Divided and distracted as we are, with almost every neighborhood threatened with civil strife, with dangerous combinations of bad men forming in different sections of the State, to frighten, rob, and, if need be, to murder the good citizens of the Commonwealth; with lawless bands of desperate men, who have nothing to lose, headed by daring and reckless leaders, already roaming over the country, plundering indiscriminately at will the men of property, influence, and position, followed by the daring, dashing, and successful adventure and invasion of the State by Col. John Morgan, at the head of a large cavalry force, which forcibly seized and carried away a large amount of valuable property belonging to the Government and private citizens; with all this, condemned by law-abiding men, staring us in the face; with numerous appeals made to me by the people, as governor of the State, to protect them in the peaceful enjoyment of their property, their liberties, and their rights under the Constitution, and totally without the means or the power to keep the peace, to protect them, or to enforce the laws; with my persistent and unavailing efforts to

organize the militia of the State under the late law, growing out of the divided sentiment of our people, their distrust of each other, and a conflict of authority with the military board, they claiming they had the paramount authority over the arsenal, arms, munitions of war, &c., under the old law, and I claiming it under the new one, which, according to my construction, reinstated me in the authority I had under the Constitution, and of which I had been deprived by a previous Legislature; with no power to organize the militia myself; with none in the military board; threatened with invasions and anarchy, I not unwillingly yielded to the request to call you together, so that you can determine by an amendment of the law, or the passage of a new one, the extent of the authority you intended to grant, and provide for the defence and protection of the people of the Commonwealth.

The governor also condemned the invasion of the State by guerillas under Col. Morgan, expressed regret at the arrest of citizens without any legal process, and recommended the adoption of the resolutions proposed by Senator Crittenden at the last session of the thirty-sixth Congress, as a standing proposition for peace, and the settlement of the war.

Immediately afterward the governor resigned his office, and James F. Robinson, secretary of state, was elected by the Legislature to fill the unexpired term. The most important subject which came under the consideration of this body during this session was the resolution of President Lincoln proposing a system of gradual emancipation to be adopted by the border slaveholding States. The report of the committee on the subject states that if a restoration of the Union, as it was, required the sacrifice of the value of their slaves, the people of Kentucky, in their opinion, would make it. It further says:

But devoted as we are to the Union, we do not feel that our loyalty demands at our hands the adoption of the measure proposed. We do not agree with the President that the gradual emancipation of the slaves in the border States would bring about a speedy termination of the war. Unhappily for our country, the dominant party in the Congress of the United States are bent on the destruction of the Constitution and the Union. No curse which the direst enemy of our country could have imposed would, in our opinion, have borne more bitter fruits than the action of that party has produced. We have viewed with alarm the rapid strides which the dominant party in Congress has made toward the prostration of every guarantee which the Constitution provides for the dearest rights of the people. They have endeavored, through the instrumentality of the executive and Congress, to strip the people of the disaffected States of their property; they have passed confiscation bills, in utter violation of the plain provisions of the Constitution; they have sought to take away from those people their State governments, and reduce them to a state of territorial vassalage; they have declared their purposes to free the slaves of the rebel States, and elevate them to an equality with the white man; they have declared that the war should be prosecuted until slavery shall be swept from the entire land; they proclaim that they are against restoration of the Union unless slavery is abolished.

The people of Kentucky justly feel horror and alarm at the enunciation of such doctrines. They will oppose them by all peaceable means, and if the time should come when the counsels of reason shall no longer be heeded, when the barriers erected by the Constitution shall no longer afford protection, then will Kentucky rise up as one man and sacrifice the

property, and, if need be, the lives of her children, in defence of that Constitution under which alone we can ever hope to enjoy national liberty. We deny what has been so often asserted by that party, that the question of slavery is the cause of the war. Disappointed ambition, grovelling lust of office and power produced it. Slavery was but the pretext for the execution of a purpose long nourished to overthrow the Government.

The report closed with a recommendation that a system of gradual emancipation of slaves be declined. This course was followed by the Legislature, and no action taken on the subject. On other subjects its action was such as to sustain the Federal Government in the great objects for which the war was originally declared to have been undertaken.

The Assembly, although expressing a conviction that the quota of troops from the State, under the calls of the President made in July and September, would be raised by voluntary enlistment, nevertheless passed an act authorizing a draft by a vote of 64 to 9. On the approach of the Confederate force to Lexington, in September, the Legislature adjourned to Louisville, where it convened. The archives of the State were also removed.

A statement of the financial condition of the State on the 31st of July reported the sum of \$423,935 in the treasury, of which \$84,169 belonged to the revenue fund; \$169,419 to the sinking fund; \$126,347 to the school fund; and \$43,998 to the military fund.

The more important military movements within the State will be found described under **ARMY OPERATIONS.**

On the 9th of June, Gen. J. T. Boyle assumed command of the Federal forces in Kentucky. On the 9th he issued the following order of instructions to his officers, thereby indicating the course which would be pursued by him:

1. All peaceful and law-abiding citizens and residents of the State must be protected in their persons, property, and rights; but citizens and residents who joined the so-called Confederate forces, or gave them aid or assistance, or went within their lines without license from the proper authorities, and have returned, or may return, and be repentant for their conduct, must report themselves to Col. Henry Dent, provost marshal of Louisville, Col. S. D. Bruce, at Bowling Green, Major Brocht, provost marshal of Lexington, or Col. Noble at Paducah, and furnish evidence of such repentance, and take the oath of allegiance, and give bonds and security for their future good conduct, and if they fail so to report themselves, they must be arrested and committed to the military prison at Louisville, and sent thence to Camp Chase, with a statement of their case, to await the action of the Secretary of War.

2. All persons who organize or aid in organizing forces for the rebellion, or organize or aid in organizing guerillas, or harbor or conceal, or give information or assistance to guerillas, must be arrested and dealt with according to military law.

3. In times of trouble like these, good, law-abiding men will refrain from language and conduct that excite to rebellion. For anything said or done with the intent to excite to rebellion, the offender must be arrested and his conduct reported, that he may be dealt with according to law.

4. When damage shall be done to the person or property of loyal citizens by marauding bands or guerillas, the disloyal of the neighbourhood or county will be held responsible, and a military commission appointed to assess damages and enforce compensation.

5. All arrests will be reported to these headquarters, with a descriptive list of the prisoners, and a full statement of the case, and the substance of the evidence, and names and residences of the witnesses.

By command of Brigadier General BOYLE.

About this time some of the lower counties of the State began to be troubled by guerillas, who committed all kinds of outrages, and kept the inhabitants in a constant state of alarm. Horses and all other valuable property were seized by them, chiefly from Union men, but often from their own friends.

At this time, about the 10th of July, a report that Col. John Morgan was approaching Lexington and Frankfort created much excitement in Cincinnati. Troops were immediately despatched from the camps in Ohio, and Lexington was occupied and placed under martial law.

On the 17th of July, Cynthiana, a village on the south fork of the Licking river, thirty-seven miles northeast of Frankfort, was occupied by Col. Morgan, with a mounted force of about two thousand men. At the same time Henderson, a town on the Ohio river, two hundred miles below Louisville, was occupied by a guerilla force. A portion of the same crossed the Ohio to Newburgh, and captured a number of arms, and made several prisoners.

The effect of these movements was to produce an immediate organization of the citizens for self-defence, which served to check them for a period, and to cause Col. Morgan to retire. Previously, however, Gen. G. O. Smith took command of the forces at Lexington, and marched in pursuit of Col. Morgan, whom he encountered near Paris. Col. Morgan was defeated with the loss of a small number killed, and twelve taken prisoners. Col. Morgan retired toward Winchester, and was rapidly pursued by Gen. Smith, who had been reinforced.

A guerilla force was also congregated at Hawesville on the Kentucky river.

On the 29th of July Russelville, on the south of Louisville, was occupied by guerillas, and on the 30th Mt. Sterling was attacked, but the enemy were repulsed by the Home Guards. In their retreat they were met by a party of the 8th Kentucky, under Major Bacht, and severely handled, losing all their horses, and several men killed.

On the 22d of August, the 54th Indiana was attacked at Bowling Green, by a guerilla force under Col. Woodward, with three pieces of artillery, to whom the former surrendered. Active operations now ensued under Gen. Bragg, and the guerillas were concentrated in his command. Col. Morgan, in a despatch by telegraph (of which he had taken possession of a station) to a former friend and Union man, boasted that he had captured seventeen cities, destroyed millions of property, and paroled 1,500 Federal prisoners. These guerilla operations, by bands of men collected in Kentucky, were continued throughout the year. The more formidable bands were organized under the act of the Confederate Congress to create "Partisan Rangers."

The provisional government of Kentucky, organized near the close of 1861, was forced to remove with the Confederate army on the approach of the Federal forces under Gen. Grant. It never had any other than a nominal existence. Persons went from Kentucky as members of the Confederate Congress, and took their seats in the Senate and House of Representatives. (See CONGRESS, CONFEDERATE.)

KNOWLES, JAS. SHERIDAN, a British dramatist, and subsequently a clergyman, born in Cork, Ireland, in 1784, died at Torquay, England, Nov. 30, 1862. He was the eldest son of James Knowles, author of a "Dictionary of the English language," and a lecturer on elocution, and received his name in consequence of his connection with the Sheridan family. At 12 years of age he began to evince a taste for that department of literature in which he afterward became so distinguished, and, it is said, composed a play for a company of juvenile performers, of whom he was the leader. At fourteen, he wrote the ballad of the "Welsh Harper." For several years he led an unsettled life, but at 22 years of age determined to make the stage his profession, and made his first appearance as an actor at the Crow street theatre, in Dublin, afterward performing in Waterford, Swansea, and various other places. In 1815,

his "Caius Gracchus" was produced in Belfast, and met with great favor, and, eight years afterward, was well received in London. His next play, "Virginus," in which Macready sustained an important part, at Drury Lane, brought him more prominently before the public. His "William Tell," "Beggar of Bethnal Green," "Hunchback," and "Wife," followed in rapid succession. After a successful tour in Europe and the United States, he produced "The Love Chase," "Woman's Wit," "The Maid of Mariendorp," "Love," "Old Maids," "John of Porcida," "The Rose of Aragon," and "The Secretary." In several of these plays he sustained the leading characters. He also delivered courses of lectures on elocution and kindred subjects. Upon the failure of his health, in 1849, a literary pension of £200 per annum was bestowed upon him, as an acknowledgment, by the crown, of his labors in the cause of literature. A few years since, he abandoned the stage for the pulpit, and became a zealous and eloquent preacher, of the Baptist denomination; since then he published two works on subjects of polemical theology—"The Rock of Rome," and "The Idol Demolished by its Own Priests." His dramatic works have been collected and published in England, in three volumes.

## L

LANDER, Brig.-Gen. FREDERICK WILLIAM, an officer of volunteers in the United States service, born in Salem, Mass., December 17, 1822, died at Pawpaw, Va., March 2, 1862. He was educated at the Dummer Academy, Byfield, and completed his studies as engineer at Partridge's Military Academy, in Norwich, Vt. After practising his profession a few years in Massachusetts, he was employed by the Government to conduct several important surveys, among which were two to determine the practicability of a railroad route to the Pacific, from the second of which, organized at his own expense, he was the only one who returned alive. In 1858 he had the command of an expedition to open a wagon road to California, across the plains. He made five explorations across the continent, as engineer, chief engineer, or superintendent, and for his celerity and efficiency was highly complimented by the Secretary of the Interior, in his official report. While engaged in this work his party were at one time attacked by the Indians, over whom they gained a complete victory, thereby ensuring safe conduct to the emigrant trains crossing the country. Of the appropriations made by Congress in two seasons alone for the construction of these roads, he brought back \$100,000 of unexpended funds. At the commencement of the civil war, in 1861, he offered his services to Gen. Scott, "in any capacity, at

any time, and for any duty," and was successfully employed on several important missions in the Southern States. After serving as a volunteer aid to Gen. McClellan in western Virginia, and participating in the capture of Philippi and the battle of Rich Mountain, he was, in July, 1861, commissioned brigadier-general, and assigned to an important command on the Upper Potomac. During the disaster at Ball's Bluff, he was at Washington arranging for the opening of the Baltimore and Ohio railroad. Receiving the intelligence of the action, he hastened to the spot, and in the skirmish which he had with the enemy opposite Edwards' Ferry, was wounded in the leg by a musket ball. Before the wound was healed he reported for duty, and was assigned the command of the forces at Romney, Va. A movement on the part of Gen. Jackson, threatening to outflank his troops, rendered it expedient for him to evacuate the position, which he did without loss, and soon after recovered it. Having discovered a Confederate camp at Bloomery Gap, he marched his four thousand men a distance of forty-three miles through deep snow, without rest and with little sustenance, and charging upon them completely routed the enemy, capturing seventeen commissioned officers and fifty privates. In this brilliant dash, the Confederate commander and his staff surrendered to Gen. Lander, who, with a single aid, had outridden the

rest of the force and coming upon them at full gallop demanded their swords. In recognition of these services he received a special letter of thanks, written by the Secretary of War in behalf of the President. Soon after Gen. Lander was compelled, in consequence of his health, to apply for a temporary respite from military duties, but before his request could be complied with, he learned that the enemy were within his reach; and while preparing for a midnight attack, died suddenly with congestion of the brain. In personal presence Gen. Lander was commanding and attractive, and as a military leader combined a spirit of the most daring enterprise with clearness of judgment in the adaptation of means to results.

LITERATURE AND LITERARY PROGRESS IN 1862.—I. IN THE UNITED STATES. The continuance of the war materially checked the enterprise of publishers, and caused the number of new works published to be greatly below that of some former years; yet the literary record of the year is by no means unimportant either in the number or character of the books issued. A number of works involving large outlay and which had been for some years in progress, were completed; others were continued as promptly and regularly as in times of ordinary prosperity, and a considerable number of important new enterprises were undertaken. The whole number of books published during the year, aside from the issues of the religious publishing societies, which are not usually enumerated among the publications of the book trade, and which are for the most part dependent upon a distinct class of agencies for their dissemination, was about 600. Of these 199 were reprints or translations, though in a number of instances the American edition was materially improved by notes and additions. The new books published by the religious publishing societies did not much if at all exceed 800. Forty-six volumes, of which only seven were translations and one a reprint, were devoted to military science and art. Of these 17 or 18 were manuals of tactics and instruction, or text books for the different branches of the military and naval service; some of them works of great merit and adopted by the Government as its manuals of instruction both in the volunteer service and in the schools of the regular army and navy. Among these were the "Authorized Infantry Tactics," prepared by Brig.-Gen. Casey; the "Course of Instruction in Ordnance and Gunnery," prepared by Capt. J. G. Benton, U. S. A.; the "Field Manuals of Evolutions of the Line," and of "Battalion Drill," by Capt. Henry Coppee; the "Naval Gunnery Instructions" of Lieut. E. Barrett, U. S. N.; the manual of "Outpost Duty" of Brig.-Gen. Butterfield; the "Manual of Engineer Troops" of Capt. J. C. Duane; Col. W. W. Duffield's "School of the Brigade and Evolutions of the Line;" Capt. Henry Heth's "Target Practice for the Use of Troops;" a new and revised edition of Maj.-Gen. Halleck's "Ele-

ments of Military Art and Science; or, Instructions in Strategy, Fortification, Tactics of Battles," &c.; Commodore U. P. Levy's (U. S. N.) "Manual of Internal Rules and Regulations for Men of War, with additional Rules for the Engineer Department by Chief Engineer A. O. Stimers;" Col. J. Monroe's Company Drill and Bayonet Fencing; "Manuals of Heavy Artillery, Light Artillery, and of Ordnance;" Lieut. E. Simpson's (U. S. N.) "Text Book of Ordnance and Naval Gunnery;" Maj. G. L. Willard's "Manual of Target Practice;" Lieut.-Col. H. B. Wilson's United States Rifle and Light Infantry Tactics; and Dr. J. J. Woodward's (U. S. A.) "Hospital Steward's Manual."

Besides these manuals and text-books, there have been a considerable number of valuable contributions to higher military science.—Prominent among these should be named the treatise of the present commander-in-chief, Major Gen. Halleck, on "International Law, or Rules regulating the Intercourse of States in War and Peace," a work which, though prepared previously to the commencement of the present war, was not published till the beginning of last year; the able essay of Prof. F. Lieber, on "Guerilla Parties considered with reference to the Laws and Usages of War;" Capt. Emeric Szabad's "Modern War; its Theory and Practice;" Capt. S. W. Benét's (U. S. A.) Treatise on Military Law and the Practice of Courts Martial; J. F. Callan's Military Laws of the United States, 1776-1863; and the timely translations of Baron de Jomini's "Art of War" and "Political and Military History of the Campaign of Waterloo," and Marshal Marmont's "Spirit of Military Institutions." An English writer, Capt. Lendy, has also made a valuable contribution to military literature in his compilation (translated from the French) of "Maxims, Advice, and Instructions on the Art of War;" as has Henry Barnard, by his compilations and translations of the history and courses of instruction in the European Military Schools. Among the lighter literature called out by the war, may be mentioned Brig. Gen. Barnard's "The C. S. A. and the Battle of Bull Run;" "Cadet Life at West Point," by an officer of the U. S. Army; Prince de Joinville's "The Army of the Potomac;" Count Anatole de Segur's "Notes from the Diary of a Soldier;" J. Cook's "Siege of Richmond;" "Stars and Stripes in Rebellion;" "Texas and its late Military Occupation and Evacuation," and "Thirteen Months in the Rebel Army," &c., by an impressed New Yorker. Our notice of military works for the year would be incomplete without mention of the valuable "Naval Text book and Naval Dictionary" of Com. B. J. Totten; "The History of the Naval Academy," by Edward C. Marshall, and the "Official Army Register" for 1862.

The literary event of the year was the completion of the New American Cyclopædia, in 16 vols. royal 8vo. The 16th volume was not indeed delivered to subscribers until Feb-

ruary, 1863, but the work was completed before the close of the year 1862. This was by far the largest and most costly enterprise ever undertaken by any publishing house in this country, involving an immense outlay, occupying a period of nearly six years, and having about 875 contributors. Unlike some of the gigantic enterprises of this description undertaken in England, the New American Cyclopædia has proved pecuniarily a success, and is unquestionably destined to attain to a further sale of many thousand copies.

The publishers of the "Cyclopædia" issued also, during the year, the first volume, uniform in size and style with that work, of an "American Annual Cyclopædia, or Annual Register of Events;" a work which was greatly needed. Of other works of reference, the American reprint of Chambers's Encyclopædia has progressed to its fourth volume, two volumes having appeared during the year; Rev. Peter Bullions, D.D., has published, in connection with his series of Classical Text Books, "A Copious and Critical Latin Dictionary" of 1,014 8vo pages; Mrs. A. O. L. Botta has issued a new and revised edition of her "Hand-book of Universal Literature," and on the Pacific coast Mr. William H. Knight has published, in a small but compact volume, a "Hand-Book Almanac for the Pacific States for 1863."

The historical works of the year have mainly had reference to the war now in progress. First among them, as a repository of the facts of history, is the "Rebellion Record" of Mr. Frank Moore, which had reached its fourth volume before the close of the year, three volumes having been issued during the year. Mr. Moore had also issued two numbers of the "Companion to the Rebellion Record," intended to form a supplementary volume of speeches and documents, and one number of "The Spirit of the Pulpit," giving a collection of the sermons of the most conspicuous clergymen, North and South, on the war. Of histories of the war, the number commenced or projected is very large. Forty-two had been announced before the close of 1862, and either numbers, or the first volume of nearly half that number, had appeared. Of these, the authors best known were: Messrs. Evert A. Duyckinck, J. R. Kennedy, J. T. Headley, J. S. C. Abbott, Thomas P. Kettell, Orville J. Victor, W. A. Crafts, Robert Tomes, M.D., Mrs. Ann S. Stephens, E. G. Storke, &c., &c.

A work of more general character, as reviewing the past history of the United States, has appeared from the pen of W. C. Fowler, LL.D., under the title of "Sectional Controversy, or Passages in the Political History of the United States." The elaborate and valuable history of "The Puritans," by Samuel Hopkins, was completed by the issue of the third volume during the year. The number of local histories was hardly as large as usual; the most important were, "History of the Town of Marlborough, Mass.," by Charles Hudson;

"A Condensed History of Cooperstown, N. Y., with a biographical sketch of J. Fenimore Cooper," by Rev. S. T. Livermore; an "Illustrated History of the Panama Railroad," by F. N. Otis; "History of Delaware County, Penn.," by Geo. Smith, M.D., and a "History of Erie County, Penn.," by Laura G. Sandford.

Among reprints, those specially noticeable, are a new edition of Hallam's "Constitutional History of England from the accession of Henry VII to the death of George II," in 8 volumes 12mo, with a continuation of the "Constitutional History from the accession of George III," by Thomas Erskine May, C. B., in 2 vols. 12mo. Both works are in the admirable typography of the Riverside press, and their form and style of publication leave nothing to be desired. "The Student's History of France," and John Francis's "History of the Bank of England from 1694 to 1844," are also noticeable reprints of works of permanent value.

Biographic literature does not present a formidable array of titles, though some of the memoirs published have been works of great merit. The most successful work in this class was the autobiographical narrative of Rev. W. G. Brownlow (better known as "Parson Brownlow"), entitled "Sketches of the Rise, Progress, and Decline of Secession, with a narrative of Personal Adventure among the Rebels." This work had reached a sale of 75,000 copies within six months after its publication. Several serials were devoted to short memoirs of persons who had become famous during the war, or of those eminent officers who had fallen in battle. Among these the most noteworthy were, "Heroes, Martyrs, and Notable Men," edited by Frank Moore; "The Fallen Brave," edited by J. Gilmory Shea, LL.D., and "The Men of the Time," edited by O. J. Victor.

Of memoirs not connected with the war, the second volume of the "Life and Letters of Washington Irving," by his nephew, Rev. Pierre M. Irving; the "Life of Rev. Nicholas Murray, D.D.," by Rev. S. J. Prime, D.D.; "Jefferson at Monticello: the Private Life of Thomas Jefferson," by H. W. Pierson, D.D.; and "Memoirs of Mrs. Joanna Bethune," by her son, Rev. G. W. Bethune, D.D., who himself passed away during the year, are the most remarkable. The Sermons of Rev. Oliver Brownson, with a Memoir of his Life, by Rev. W. B. Sprague, D.D.; a Sermon, with biographical sketch of Rev. Timothy Woodbridge, "the blind minister," from the same facile and eloquent writer; a "Discourse on the Life, &c., of Count Cavour," by Vincenzo Botta, Ph. D.; the "Life, Times, and Correspondence of Rt. Rev. Dr. Doyle," by W. J. Fitzpatrick, and a brief sketch of "Martin Van Buren, Lawyer, Statesman, and Man," by William Allen Butler, also belong to this class. "The Life of Mary, Queen of Scots," by Donald MacLeod, is another effort to settle one of the vexed questions of history, the more difficult of



settlement from the extraordinary beauty and grace of its subject.

Genealogy is akin to biography, and in this field the contributions, though few, have been of great importance. James Savage has completed during the year, by the publication of the third and fourth volumes, his "Genealogical Dictionary of the First Settlers of New England," a colossal undertaking, and one requiring an amount of patient and persevering labor for which few are competent. Mr. William H. Whitmore has also published in a quarto volume, a "Handbook of American Genealogy;" and Mr. O. S. Sims has furnished to the public an interesting treatise on the origin and signification of Scotch surnames.

The reprints in biography are not numerous. The most remarkable are Mrs. Oliphant's "Life of Edward Irving," a work of deep interest both from the remarkable character of the subject, and the relations existing between him and his biographer; the "Life of Arthur Vandeleur, Major Royal Artillery," by the author of "Life of Capt. Hedley Vicoars," and "Louise Juliane, Electress Palatine, and her Times," by Fanny Elizabeth Bunnett.

In the theological and religious literature, of sixty-eight titles, just one half are reprints or translations, though several of the works have received valuable additions from their American editors. Of the American works, none possess such extraordinary merit as to entitle them to extended notice. Rev. Abel Stevens, D.D., LL.D., published the 3d volume of his "History of the Religious Movement of the 18th century, called Methodism;" Rev. J. H. Kurtz, D.D., an eminent Lutheran clergyman, prepared a "Text-Book of Church History from the Reformation to the Present Time;" Rev. J. S. C. Abbott, a treatise on "Practical Christianity," a continuation of his Young Christian Series; Rev. Hollis Read, a religious writer of considerable reputation, a work on the "Coming Crisis of the World, with an Introductory Note by S. H. Tyng, D.D.;" Rev. Joseph H. Allen, "Hebrew Men and Times; from the Patriarchs to the Messiah." "Solomon's Song, Translated and Explained," by Rev. Leonard Withington, D.D., is a brief but admirable commentary, from the pen of a writer who does not appear in print as often as the public desire. Of volumes of sermons, discourses, and public addresses published during the year, the number is considerable. The last collected volume of the sermons of the late Rev. Dr. James W. Alexander, is a series of discourses on Faith; a series of Discourses on Sacramental Occasions, delivered by the late Rev. Ichabod T. Spencer, D.D., have been published, with an introduction by the venerable Dr. Gardner Spring; Rev. W. G. T. Shedd, D.D., late professor at Andover, but now colleague pastor of Dr. Spring, has published a volume of "Discourses and Essays" of great logical power and ability. Rt. Rev. C. P. McIlvaine, bishop of Ohio, defends, in a

series of discourses, the doctrine of "Righteousness by Faith;" Rev. William R. Scott, late of San Francisco, has given to the public a volume of sermons, under the somewhat singular title of "The Church in the Army; or, The Four Centurions." "The National Preacher and Village Pulpit," a monthly serial, containing sermons from conspicuous living clergymen of the United States, has a wide circulation, and is edited with decided ability.

A volume entitled "Sermons and Speeches," and containing the public discourses on religious topics, and the addresses of the noted anti-slavery orator, Gerrit Smith, was published in the early part of the year. Among the other religious works of the year are: Rev. Dr. Nehemiah Adams' "Broadcast," a collection of thoughts, apophthegms, illustrations, as gathered during a long period of ministerial labor; "The Christian Sabbath; its History, Duties, etc.;" Rev. James Chrystal's "History of the Modes of Christian Baptism;" Rev. Dr. H. Darling's "The Closer Walk; or, The Believer's Sanctification;" Mrs. E. H. B. Mason's "Great Expectations Realized," a singular medley of autobiography, missionary experiences, and advocacy of direct effort for the religious instruction of Burmese women; "Meditations on the Duties of Clergymen;" "Prayers," by the late Theodore Parker; "The Prodigal Son, or the Sinner's Departure and the Sinner's Return," by Rev. Geo. E. P. Rogers, D.D.; "Sacred Cosmogony," by the Abbé A. Sorignet. Rev. J. A. Seiss, D.D., "The Parable of the Ten Virgins."

The most noticeable of the reprints of this class are Peter Bayne's "Testimony of Christ to Christianity;" "Essays and Reviews" (4th American from 2d London edition); "Aids to Faith; a series of Theological Essays, being a reply to Essays and Reviews;" "Replies to Essays and Reviews;" Bishop Colenso on the "Pentateuch and Book of Joshua," part I; Arthur Penrhyn Stanley, D.D., Lectures on the History of the Eastern Church; O. J. Ellicott, D.D., Historical Lectures on the Life of our Lord Jesus Christ, and Critical and Grammatical Commentary on Ephesians, with revised translation; Brooke Foss Westcott's Introduction to the Study of the Gospels, edited with preliminary essay, by H. B. Hackett, D.D.; Dr. Thomas Guthrie's "The Way to Life;" the 2d volume of Dr. K. R. Hagenbach's "Text Book of the History of Doctrine," revised with large and very valuable additions, by Prof. H. B. Smith; Rev. William Hanna, LL.D., "The Last Day of our Lord's Passion;" Hay's Devout Christian Instructed in the Faith of Christ; Father Senescalchi Ligorio, S. J., "Meditations of St. Ignatius; or, Spiritual Exercises," translated from the Italian; Rev. James McOosh, LL.D., "The Supernatural in Relation to the Natural;" "Patience of Hope," by the author of "A Present Heaven," with an introduction by J. G. Whittier; Spurgeon's Sermons, 7th series; Octavius

Winslow, D.D., "The Sympathy of Christ with Man; its Teaching and its Consolation;" a new edition of Cardinal Wiseman's "Lectures on the Principal Doctrines and Practices of the Catholic Church."

In Moral, Intellectual, and Political Science, there have been several works issued of decided merit. Among these may be named President Mark Hopkins's "Lectures on Moral Science;" Mr. J. Bascom's "Æsthetics, or the Science of Beauty;" President J. T. Champlin's "First Principles of Ethics;" Prof. C. K. True's "Elements of Logic;" Mr. P. McGregor's "System of Logic;" B. R. Curtis' Essay on "Executive Power;" Rev. M. D. Conway's "The Rejected Stone; or, Insurrection *æ*. Resurrection in America;" and Furman Sheppard's "First Book of the Constitution of the United States." Several of the reprints in this class are also works of great ability. Prominent among these are Prof. J. E. Cairnes' "The Slave Power, its Character, Career, &c.;" Count A. de Gasparin's "America before Europe; Principles and Interests," translated by Mary L. Booth; John Stuart Mill's "Considerations on Representative Government," and "The Contest in America." The elegant library edition of Lord Bacon's works, was completed by the issue of the 3d and 4th volumes. Prof. F. Bowen, of Cambridge, edited with notes, a new edition of Reeve's translation of De Tocqueville's "Democracy in America."

In physical and mechanical science, a department for many years past diligently cultivated in the United States, many important works were issued. Among them were: the 4th volume of Prof. Agassiz' magnificent "Contribution to the Natural History of the United States;" a revised edition of J. J. Audubon's "Birds of America;" Prof. James D. Dana's "Manual of Geology;" A. A. Gould, M.D., "Otia Conchologica; Description of Shells and Mollusks, from 1839 to 1862;" Hermann Hagan's "Synopsis of the Neuroptera of North America;" with a list of the South American Species;" William Stimpson's "Notes on North American Crustacea in the Museum of the Smithsonian Institution;" Prof. James Hall's third volume of the "Palæontology, in the Natural History of New York;" Prof. James Hall and J. D. Whitney's "Report on the Geological Survey of the State of Wisconsin;" a new edition of Dr. T. W. Harris' "Treatise on some of the Insects Injurious to Vegetation," edited by Charles L. Flint; Mr. John S. Hittell's admirable essay on "Mining in the Pacific States of North America;" Capt. A. A. Humphreys and Lieut. H. L. Abbott's "Report on the Physics and Hydraulics of the Mississippi River;" H. Ruttan's "Treatise on Warming and Ventilating Public and Private Buildings," developing his new and admirable system; Mr. G. W. Tryon's "List of American Writers on Recent Conchology," with the titles of their memoirs and dates of publication; and the Annual of Scientific Discovery for 1862.

New editions were also published of Dr. A. Snowden Piggott's "Chemistry and Metallurgy of Copper;" E. C. Perkins' "Practical Treatise on Gas and Ventilation;" Commander J. H. Ward's "Steam for the Million;" Prof. Gillespie's "Manual of the Principles and Practice of Road Making," and Engineer W. R. King's "Notes on the Steam Engine, Propellers, &c., for Young Marine Engineers, Students," &c.

In philology, the most noteworthy books of the year were the "Origin and History of the English Language," by George P. Marsh, LL.D., U. S. minister to Italy; a work of profound learning and research, by the ablest of American Philologists; and an edition of vol. I of Hensleigh Wedgwood's "Dictionary of English Etymology," with notes which more than double its value, by Mr. Marsh; while Prof. R. L. Tafel's "Investigations into the Laws of English Orthography and Pronunciation;" Messrs. R. Soule and W. A. Wheeler's "Manual of English Pronunciation and Spelling;" Prof. William Henry Green's "Grammar of the Hebrew Language," and Rev. M. C. Padosy's "Grammar of the Yakama Language," translated by George Gibbs and J. Gilmary Shea, and forming one of the volumes of Dr. Shea's invaluable "Library of Linguistics," are all important contributions to philological science.

In mathematics the most remarkable books are Mr. J. W. Nystrom's "Project of a New System of Arithmetic, Weights, Measures and Coins," proposed to be called the Tonal System with Sixteen to the Base; and a scientific treatise on the "Laws and Practices of the Game of Euchre." In educational science, aside from the new series of Dr. Barnard's American Journal of Education, a work of great value and importance, there was published an admirably arranged "Graded Course of Instruction for Public Schools, by William H. Wells, A.M., Superintendent of Public Schools in Chicago;" a Manual of Instruction on the Plan of Object Teaching, by Marcus Willson; a report of the "Proceedings of the Educational Convention at Oswego, Feb., 1862;" and an able essay in opposition to the so-called Object Method of Teaching, entitled "Some Suggestions on the Principles and Methods of Elementary Instruction," by H. B. Wilbur, M.D., Superintendent of the New York State Asylum for Idiots.

The number of new works on agriculture is not large, though the agricultural periodicals are liberally sustained, and some of them display a high order of talent. Two works were published on wine making and the grape culture: one, Mr. A. Haraszthy's, with special reference to California, where wine making is becoming an important branch of productive industry; the other by Mr. John Phin, devoted to open air grape culture generally. From San Francisco, there comes also a Beekeeper's Directory, the keeping of bees having proved very profitable on the Pacific coast.

Messrs. G. B. Emerson, M.D., and Charles

L. Flint published early in the year a "Manual of Agriculture for the School, the Farm, and the Fireside," intended to introduce the elementary principles of scientific agriculture into the course of common school instruction. Mr. Edward Parrish of Philadelphia introduced a new art to the attention of the curious in a little volume entitled "The Phantom Bouquet; a Treatise on the Art of Skeletonizing Leaves and Seed Vessels."

The larger part of the new medical works of the year have a bearing on surgery, and especially military surgery; on this subject treatises have been published or former treatises revised, by some of the ablest members of the profession, such as Drs. Gray, Gross, Guthrie, Longmore, Powers, and Sargent. Of treatises on other medical topics, may be named Dr. Barclay's "Manual of Medical Diagnosis;" Dr. J. Byrnes's "Researches on Pelvic Hæmatocæle;" Dr. J. Frick's "Physical Manipulations," translated by Dr. J. D. Eaton; Dr. John O'Reilly's elaborate treatise on the "Placenta," &c.; Dr. Henry W. Williams' "Practical Guide to the Study of Diseases of the Eye;" Dr. George H. Smith's monograph on "The Insertion of the Capsular Ligament of the Hip Joint," and Dr. C. H. Cleaveland's "Causes and Cure of Diseases of the Feet." In hygiene, Dr. Dio Lewis has published a most admirable system of "New Gymnastics for Men, Women, and Children;" the venerable R. D. Mussey, M.D., LL.D., a capital essay entitled "Health; its Friends and its Foes;" Mr. A. J. Davis, "The Harbinger of Health;" and Dr. W. W. Hall, a ninth volume of his spicy and eminently readable "Journal of Health." Dr. O. W. Holmes, whose brilliant position in literature does not diminish his interest in his profession, published during the year two volumes as contributions to medical literature, viz., "Border Lines of Knowledge in some Provinces of Medical Science," and "Currents and Counter-Currents in Medical Science, &c." The most valuable of the reprints were the two admirable summaries of medical and surgical knowledge, Braithwaite's Retrospect, and Ranking's Half-Yearly Abstract of the Medical Sciences. The number of books of travel, or treatises on the habits and manners of foreign countries, have been very few. Rev. W. H. Bidwell, editor of the Eclectic Magazine, has compiled a volume of biographical sketches, entitled "Imperial Courts of France, England, Russia, Prussia, &c.," with 42 fine steel portraits, as a presentation volume. A lively little volume of incidents of travel in the islands of the southern seas, appeared under the title of "Life and Adventures in the South Pacific, by a Roving Printer." Messrs. Harper published a "Handbook for Travellers in Europe and the East," by W. P. Fetridge, and the publishers of Rev. T. Starr King's charming "White Hills, their Legends, Landscape, and Poetry," issued a cheaper edition of it. Two books by English writers on portions of this country, were re-

printed here almost simultaneously with their appearance in England, viz., Capt. R. F. Burton's "City of the Saints, and Across the Rocky Mountains to California," and Mr. Anthony Trollope's "North America." The lively work of the Princess Belgiojoso on "Oriental Harems and Scenery," was also translated from the French and republished here.

In the way of essays and lighter literature, not fictitious, a number of works of great merit appeared; among these was a new volume by Timothy Titcomb (Dr. J. G. Holland), in his admirable and peculiar vein, entitled "Lessons in Life, a Series of Familiar Essays;" a volume characterized by remarkably vigorous and powerful thought and vivid powers of description, entitled "Country Living and Country Thinking," by Gail Hamilton (Miss A. Dodge); a collection of papers mostly communicated to the New York Ledger, by Henry Ward Beecher, under the title of "Eyes and Ears;" a vigorous essay on the times, by Rev. Marcus D. Conway, entitled "The Golden Hour;" a narrative of the doings of Maj.-Gen. Fremont's famous body-guard, from the pen of Mrs. Fremont, under the title of "The Story of the Guard; a Chronicle of the War;" an address with notes, &c., by John S. Hart, LL.D., entitled "Mistakes of Educated Men;" a collection of essays, addresses, &c., of much merit, on the "Future of Africa," by Rev. Alex. Cromwell, a man of color, and professor in the Liberia College; a new volume of miscellaneous sketches and letters, by Bayard Taylor, entitled "Home and Abroad; a Sketch Book of Life, Scenery, and Men, 2d series;" a series of humorous and satirical letters on the war, displaying keen wit and trenchant powers of sarcasm, entitled "The Orpheus C. Kerr (Office Seeker) Papers."

Among the essays and narratives more directly pertaining to the war were an essay by Mr. William Whiting, on "The War Powers of the President, &c.;" an able exposition, by Mr. Henry T. Tuckerman, of "The Rebellion, its latent causes and true significance;" an essay of remarkable ability by Mr. Alfred Stille, of Philadelphia, entitled "Must the War go on;" narratives of adventures as prisoners of war, by Hon. Alfred Ely, M. C. from New York, and Lieut. William C. Harris; a "Narrative of the Campaign of the First Rhode Island Regiment in the spring and summer of 1861," by Rev. Augustus Woodbury; and three or four pamphlet reports of speeches by Mr. George Francis Train, in England, relative to the war and kindred topics. In addition to these, there were a few essays on subjects not readily classified, as, for instance, the "Ethical and Physiological, chiefly relative to subjects of popular interest," of Mr. A. H. Dana; Mr. Eli Bowen's treatise on the "Creation of the Earth;" "Record of an Obscure Man," and "Climbing the Mountains," both by anonymous authors. The only reprints worthy of special notice were "The Book Hunter," by

John Hill Burton, enriched with an introduction and notes by Richard Grant White; the "Spirit of the Hebrew Poetry," by the venerable Isaac Taylor, with a biographical introduction by William Adams, D.D.; "Two Friends," by the author of "The Patience of Hope;" two more volumes by "The Country Parson," and J. C. Jeaffreson's "Book about Doctors."

Of the 188 volumes of novels published in 1862, only 84 were by American authors; but some of these possessed a high degree of merit, and attained a large sale. Remarkable success was achieved by the work of a new author, "Among the Pines," by Edmund Kirke, a description of Southern plantation life, and the hopes, aspirations, and plans of the slaves for the attainment of freedom. In graphic power and fidelity to nature, it was pronounced by some critics equal to "Uncle Tom's Cabin," though lacking somewhat, perhaps, in the artistic ability of that work. Mrs. Stowe's two novels, "Agnes Sorrento" and "The Pearl of Orr's Island," met with a hearty and not undeserved welcome; the posthumous novels of Major Theodore Winthrop (a young officer of great promise, who fell at Great Bethel in the summer of 1861), "Cecil Dreeme," "John Brent," "Edwin Brothertoft," and the "Canoe and Saddle," were also favorably received. Among other novelists of known reputation, Marion Harland's (Mrs. Terhune) "Miriam," Richard B. Kimball's "Undercurrents of Wall Street, a Romance of Business," Mr. A. S. Roe's "Like and Unlike," "Sutherlands," by the author of "Rutledge," Mrs. C. H. B. Richards' ("Mrs. Manners") "Springs of Action," Mrs. Mary A. Denison's "The Master," and Mrs. E. D. E. N. Southworth's "Broken Engagement," "Hickory Hall," and "Love's Labor Won," all attained a fair, and some of them a large, measure of success; while among the new aspirants for fame, as writers of fiction, Mrs. Elizabeth Stoddard (wife of the poet, R. H. Stoddard), in her "The Morgesons," and the authoress of "Margaret Howth, a Story of To-Day," were received with great favor. Others, as, for instance, T. B. Aldrich (already favorably known as a poet), in his "Out of his Head, a Romance;" Kinahan Cornwallis, in his "Pilgrims of Fashion;" E. S. Gould, in his "John Doe and Richard Roe, or Episodes of Life in New York;" Virginia Townsend, in her "Amy Deane, and other Tales," and one or two others, though perhaps not less deserving than those named above, did not achieve such marked success.

The most remarkably successful novel of the year, all things considered, was Victor Hugo's "Les Miserables." It was at first published here in five volumes, in an American translation, and subsequently the five volumes bound in one. After some months a reprint of an English edition, somewhat abridged, was put upon the market, and the sales of the two editions reached, before the close of the year,

about 50,000 copies. Some of the reprints of English and French novels have been very favorably received; among these may be mentioned Bulwer ("A Strange Story"), "Chronicles of Carlingford," Wilkie Collins ("After Dark," "Sister Rose," "The Yellow Mask," "Stolen Mask," and "Hide and Seek"), author of Margaret Maitland ("Last of the Mortimers," and "Lilliesleaf"), Chas. Lever ("Barrington"), Miss H. Martineau ("The Woman I Loved and the Woman who Loved me"), Miss D. M. Mulock ("Mistress and Maid, a Household Story"), Charles Reade ("The Cloister and the Hearth"), Geo. A. Sala ("Seven Sons of Mammon," and "Two Prima Donnas"), Anthony Trollope ("Orley Farm," "The Warden," "Barchester Towers," and "The Struggles of Brown, Jones, and Robinson"), "Why Paul Ferroll killed his wife," Mrs. Henry Wood ("The Channings," "The Mystery," "The Heir to Ashley," and "Earl's Heir"), Miss Yonge ("The Young Stepmother, or a Chronicle of Mistakes"), W. M. Thackeray ("The Adventures of Philip on his Way through the World"), Mrs. S. C. Hall ("Can Wrong be Right?") Gustave Aimard ("The Trail Hunter," "Flower of the Prairie," "Pirates of the Prairies," and "Indian Scout"), Alexander Dumas ("André de Taverney," "Castle of Souday," and "Twin Lieutenants"), Balzac ("Eugene de Grandet"), Madame Emile de Girardin ("Marguerite, or Two Loves"). Of far higher character than these, and belonging rather to the class of allegories than novels, is the Countess de Gasparin's "Vesper." Among new editions of standard novels, we have the beautiful household edition of Dickens, of which 15 volumes, comprising "Dombey," "Martin Chuzzlewit," "Barnaby Rudge," and "David Copperfield," have appeared during the year. Miss Jane Austen's works, complete in 4 volumes, in uniform style, comprising "Emma," "Mansfield Park," "Sense and Sensibility," "Persuasion," "Pride and Prejudice," and "Worthanger Abbey."

The year was not prolific in poetry of a high character. Only three volumes of considerable size and containing new poems of merit, appeared. These were Bayard Taylor's "Poet's Journal and Autobiography;" Thomas Buchanan Read's "Wagoner of the Alleghenies: a Poem of the Days of '76," and Rev. T. H. Stockton's "Poems with Autobiographical and other notes." A few short poems or collections of lyrics, mostly called forth by the war, such as G. W. Hewes' "Ballads of the War;" "Rhymed Tactics," by "Guv.;" "Rifle Shots at Past and Current Events;" "Midnight Chimes; or, the Voice of Hope;" "Meditations and Hymns," by X.; "The Flying Dutchman," by J. G. Saxe; and "The Branch; a Sacred Poem, and other Poems," have also made their appearance, but have generally excited little attention. The poems of O. W. Holmes, Longfellow, Bayard Taylor, Tennyson, and Mrs. Barrett Browning, have been collect-

ed and published in new and complete editions mostly in the blue and gold style; and the poetical works of Adelaide Anne Procter (daughter of the poet B. W. Procter) ("Barry Cornwall"), Arthur Hugh Clough, and William Allingham, have been published in a style uniform with them. Among the compilations of great merit may be named, Prof. F. J. Child's "Poems of Sorrow and Comfort," and Prof. F. D. Huntington's "Series of Hymns of the Aæa." The admirable edition of Shakespeare edited by Richard Grant White was completed during the year by the publication of the 9th, 10th, 11th, and 12th volumes. Dr. J. G. Holland's poem "Bittersweet," published four or five years ago, has been reprinted with 50 exquisite illustrations.

In juvenile literature, the year has been less prolific than many former ones. Many publishers have adopted the custom of having their works for the young prepared in sets of four, six, eight, or twelve volumes, and these, though usually written by the same author, are often of very unequal merit, the sale being for the most part in sets, and the better volumes securing the sale of the poorer. Among the juvenile works of the year, are eight or ten of these sets comprising in all about 60 volumes. Rev. Jacob Abbott is, as usual, the most prolific of the writers for the young, having furnished, in addition to the "Harlie Stories" in six volumes, a fourth volume of his American history for the young ("Northern Colonies"), and a fourth volume of "Florence Stories" ("The English Channel"). Rev. J. Banvard, D. D., has also published a series entitled "Story Truths," and the author of the "Night Cap series" has followed those popular juveniles with the "Mitten Books," a set of six volumes. Mrs. Madeline Leslie (a daughter of the late Rev. Dr. L. Woods, of Andover Theol. Seminary) has published during the year four very charming juveniles, "The Bound Boy and Young Soldier," "Sequel to Tim the Scissors Grinder," "The Bound Girl and other Stories," and "The Two Homes; or Earning and Spending." Mrs. Horace Mann is the author of an interesting little book entitled "Flower People." Rev. D. C. Eddy, now of Philadelphia, has contributed another volume to his series on foreign countries, under the title of "Walter in Egypt." Other interesting juveniles are, "Buy an Orange, Sir? or the History of Jamie Woodford;" "Wayside Flowers," by Carrie Carlton; Ellie's, and Jeanie's scrap-books (two volumes); "Johnny Wright, the Boy who tried to do right;" "Little Brown Bible;" "Harry's Mistakes, and where they led Him," by M. A. Parrott. Among reprints the "A. L. O. E. Stories" take the lead; that attractive writer for the young having added during the year six more to her already very long list of children's books. In the class of what for want of a better term may be called "Crusoe Books," there are three volumes which will afford great pleasure to boy readers. "Dog Crusoe,"

and "The Gorilla Hunters, a tale of the Wilds of Africa," both by P. M. Ballantyne, and the "Bear Hunters of the Rocky Mountains," by Annie Bowman. The only other noticeable reprints are, "Lines left Out," by the author of "Line upon Line," "The Old Lieutenant and his Son," by Norman Macleod," "The Exiles of Madeira," by Rev. W. M. Blackburn, and "Life Lessons, or Scripture Truths illustrated for the young," by Rev. James Bolton.

II. ENGLISH LITERATURE.—The space to which this article is necessarily restricted, will not admit of so full an analysis of the literature of Great Britain as has been given of that of the United States; but this is the less to be regretted, as a large portion of it has been already noticed under the head of reprints. A glance at the principal works of the year in each department is all for which there is space or necessity.

In theology and religious literature, the engrossing topic of the early part of the year was "Essays and Reviews," to which numerous replies were published, and as these provoked rejoinders and replications, not less than sixty volumes were published on the subject during the year. The interest awakened by these "Essays" had not subsided, when the works of Bishop Colenso on the Romans and the Pentateuch and Book of Joshua aroused a new controversy, which is still raging. Aside from the works connected with these two controversies, there have been published several interesting books on Church History, by Canon Stanley, Dr. Vaughan, the late Dr. Cunningham, Dr. Howsen, Messrs. Angers and Waddington, and a translation from the Russian of Popoff of the "History of the Council of Florence;" a work on "Biblical Criticism" by Dr. Davidson; two able works on Brahminism and Buddhism; and several memoirs and didactic works of merit. Many of the works of history and biography are of local character, and have comparatively little interest for readers in other countries; others, and a very considerable number, are compilations of greater or less merit by such indefatigable bookwrights as John Timbs, Horace Welby, Samuel Lucas, Erskine Neale, and G. Fletcher. But, aside from all these, there have been more than ordinary valuable contributions during the past year to the works of permanent value in these departments. Such works as Sir G. Cornwall Lewis's "Historical Survey of the Astronomy of the Ancients;" Rev. Charles Merivale's "History of the Romans under the Empire;" Mr. George Rawlinson's "Five Great Monarchies of the Ancient world;" Dyer's "History of Modern Europe, from the Taking of Constantinople to the close of the War in the Crimea;" Sayer's "History of Gibraltar;" Lord Stanhope's "Life of William Pitt;" Spedding's "Life of Francis Bacon" (republished here in connection with the Riverside edition of Bacon's works); Lady Morgan's "Memoirs, Autobiography, and Correspondence;" Prof.

Wilson's (Christopher North) "Memoirs, by his Daughter;" "The Life of John Graham, Viscount Dundee" (the Claverhouse of the Waverley Novels); Dean Milman's "Memoir of Lord Macaulay," &c., &c., cannot be regarded as ephemeral in character.

Geographical works and narratives of travel have for many years formed a very large constituent of the current literature of Great Britain, and many of them possess great value. Several new atlases and manuals of geography have appeared during the year, which, though generally inferior in accuracy to the best German geographical works of the class, have yet no inconsiderable merit. The volumes of travel and exploration are almost numberless, and hardly any portion of the globe has been left unvisited. The less frequented peaks and passes of the Alps have been admirably described by the Alpine club, Prof. Tyndall, Mrs. Freshfield, and Francis Galten; while the mountains of Lebanon, Iceland, and the Faroe Islands, Wales, the Pyrenees, Italy, Calabria, and the Liparian Islands, Dalmatia, Servia, Borneo, Greece, Turkey, Russia, Finland, Sweden, and "Gomle Nergo" (old Norway), have each been visited and described by the tourists; and even the Channel Islands have been most admirably and accurately portrayed in all their physical aspects by Profs. Ansted and Latham. African travellers are not so numerous as a few years ago; yet there are works on Thebes, on Egyptian travel generally, Algeria, the Niger, Abyssinia, and a volume of wonderful adventures in hunting in South Africa, by Mr. William Charles Baldwin, since reprinted in this country. In Asiatic exploration there are two books on Afghanistan, three or four on China, of which Commander Brine's "The Taeping Rebellion," and Capt. Blakiston's "Five Months on the Yang-Tsze," are specially noteworthy; as are Lieut.-Col. Torren's "Travels in Ladak, Tartary, and Kashmir," and Mr. Spencer St. John's "Life in the Forests of the Far East," a book of travels in northern Borneo. Of half a dozen books on Australia, the most noticeable are "Thirty-three years in Tasmania and Victoria," by G. T. Lloyd, and "Robert O'Hara Burke and the Australian Exploring Expedition," by Andrew Jackson; Dr. Russell of the London "Times," published his "Diary North and South" (reprinted here), and another "Own Correspondent" (S. P. Day), "Down South." Mr. E. B. Underhill has issued an interesting volume on the "West Indies;" and British Columbia and Vancouver's Island have been described by five or six writers, among whom Mr. Forbes Macdonald and Mr. Alexander Rattray have, by the thoroughness and accuracy of their books, established the best claim to the attention of the emigrant or tourist. Prof. Berthold Sumann gives the result, in an interesting volume, of his "Mission of Exploration to the Viti or Fiji Islands;" and Mr. Manley Hopkins has given a very readable resumé of what is known of the Hawaiian Isl-

ands. In island explorations the "Narrative of the Circumnavigation of the Globe," by the Austrian frigate Novara, is very valuable. The scientific corps of that vessel took especial pains to explore islands hitherto little known.

The department of science and art is especially rich in the literature of the current year. In physical science and zoology, the number of valuable books is very large. Three elaborate works are devoted to "British Birds;" to "European birds not British," and to "Our Feathered Families," by Messrs. Bree, Morris, and Adams; "Exotic Butterflies have their Attorney;" and the various phenomena and peculiarities of animal life have met with patient observers and able describers. The number of botanical works exceeds a dozen—three of which are devoted to ferns; and Charles Darwin has, in one of those admirable essays which speak of such accurate and continued observation, described "The Contrivances by which British and Foreign Orchids are Fertilized by Insects." Geology, palæontology, chemistry, mechanics, geography, and geodesy, have each furnished the subject of contributions to science, while in astronomy and its cognate sciences are several books of great interest.

In architectural and art works the most remarkable book was Mr. James Ferguson's magnificent "History of the Modern Styles of Architecture," with 812 illustrations; a new and improved edition of Sir William Chambers' "Treatise on the Decorative Part of Civil Architecture;" "Pictures of English Landscape," by the Brothers Dalziel, with "Pictures in Words," by Tom Taylor; Dicks' "Studies from the Great Masters, with Letter Press Descriptions;" and several treatises on military drawing, surveying, engineering, &c. In antiquities there are two works of interest: "Colossal Vestiges of Olden Natures" (describing Stonehenge, &c.); and Mr. Samuel Sharpe's "Essay on the Egyptian Antiquities in the British Museum." The contributions to philology have been of great importance; the most remarkable are: "Langue Basque et Langues Finnoises," by Prince Lucien Bonaparte; "English Retraced" (a comparison of the English of the sixteenth century with that of to-day); "Elements of Comparative Philology," by R. G. Latham; G. L. Craik's "Manual of the English Language from the Norman Conquest;" "Essay on the Origin and Formation of the Romance Languages" (a new edition), by the late Sir G. Cornwall Lewis. In moral and mental philosophy, politics, sociology, education, &c., the most noticeable works are "First Principle," by Herbert Spencer; "An Inquiry into the Theories of History, with Special Reference to the Principles of the Positive Philosophy;" "Unto This Last;" "Essays on Political Economy," by John Ruskin; "The Criminal Prisons of London," &c.; Professor F. D. Maurice's "Modern Philosophy, from the Fourteenth Century to the French Revolution, with a Glimpse into the Nineteenth Century;"

Sir J. Kay Shuttleworth's "History of Our Educational System in the Four Periods of 1832, 1839, 1846, and 1852;" and Dr. G. H. Townsend's "Manual of Dates."

The publishers of Mr. Charles Knight's "English Cyclopædia" issued a "Synoptical Index" of the four divisions of that work, giving great facility of reference to the different sections.

The number of books issued in the extensive departments of fiction and juvenile literature was very great; but most of those possessing a high order of merit were reprinted in the United States. The whole number of original works published in Great Britain during the year was somewhat above 3,000, beside reprints and translations.

LOUISIANA, the great sugar-producing State in the southwestern part of the United States, has a population, according to the census of 1860, of 357,629 whites, 18,647 free colored, and 381,726 slaves; total, 708,002. The ratio of increase in her population during the previous ten years has been, white 39.93, free colored 6.78, slave 35.50. The white male population was 189,648, female 167,808. The population of New Orleans in 1860 was 168,675; in 1850 it was 116,375—increase in ten years, 52,300. The increase in the whole State during the same period was 180,240. The number of slaves manumitted in ten years was 517; the number of fugitives, 46. The mortality in the State during the year ending May 31, 1860, was 12,329. The most fatal diseases were consumption, diarrhœa, dysentery, fevers, and pneumonia. The number of deaf mutes was 215, of whom 38 were slaves. The industrial products of the State during the year ending June 1, 1860, were as follows: Iron founderies \$525,800; lumber, \$1,018,554; flour and meal, \$11,694; cotton goods, \$509,700; leather, \$47,000. Total value of all products of industry, \$15,500,000. The value of real and personal estate was \$602,118,568. Improved lands 2,734,901 acres, unimproved 6,765,879, value of farms or plantations \$215,565,421. Number of horses 79,068, mules and asses 92,259, milch cows 180,672, working oxen 61,008, other cattle 329,855, sheep 180,855, swine 642,855; total value of live stock \$24,751,822. Crops raised were as follows: Wheat, 29,282 bushels; rye, 12,789 bush.; corn, 16,205,856 bush.; oats, 65,845 bush.; rice, 6,455,017 lbs.; tobacco, 40,610 lbs.; cotton, 722,218 bales of 400 lbs. each; wool, 296,187 lbs.; peas and beans, 430,410 bushels; potatoes, Irish, 332,725 bush.; potatoes, sweet, 2,070,901 bush.; sugar, 297,816 hhd.; molasses, 14,535,157 galls.; miles of railroads, 334; cost of construction, \$12,020,204.

The educational institutions of the State consisted of the University of Louisiana, College of the Immaculate Conception, St. Charles College, Centenary College, Washington College, Mt. Lebanon University, and St. Joseph's College. Some of them are now closed in consequence of the war.

The change which took place in the political and military affairs of the State previous to the occupation of New Orleans by the Federal forces, on May 1, is unimportant. Her commerce was entirely cut off by the blockade, and the stagnation produced by the war was chiefly experienced at New Orleans, where large numbers were obliged to resort to the free market, established by the city, to procure subsistence. The number of troops which had been sent by the State to Virginia up to the beginning of February was small. They consisted of the following regiments and battalions: the 1st, Col. Vincent; 2d, Col. W. M. Levy; 5th, Col. T. G. Hunt; 6th, Col. I. G. Leymore; 7th, Col. H. T. Hays; 8th, Col. H. D. Kelly; 9th, Col. E. G. Randolph; 10th, Col. M. Marigny; 14th, Col. V. Sulakouski; battalions: Washington artillery, 1st, 3d, and 4th, Wheat's battalion, St. Paul's battalion, Louisiana zouaves, and three independent companies.

Military affairs, however, continued stagnant until the advance of the Federal forces at the West aroused the Confederate States to the danger which threatened them. Gen. Beauregard was then sent to take command in the West, and President Davis issued a call for more troops. On the 14th of February, Gov. Moore issued a proclamation calling for volunteers to meet this requisition from President Davis for five and a half regiments.

On the 16th Fort Donelson was captured, and the Federal advance was immediately made upon Nashville. Gen. Beauregard, aware of the true state of affairs, immediately sent the most pressing requests to the governors of Tennessee, Mississippi, and Louisiana for troops. The urgency of this appeal is developed by the entreaties which the governor and the messenger of Gen. Beauregard addressed to the people. The governor's appeal was as follows:

FELLOW-CITIZENS AND SOLDIERS: I address you to-day in a double capacity, as governor and commander-in-chief. A call has been made upon me by Gen. Beauregard for 5,000 men to defend the Mississippi Valley, and with it your loved State, this beautiful city, and more than all, our homes and those dearer than all else, save honor. The laggard and the dastard await the foe at the very shrine of the sanctuary. It is the part of the brave and noble hearted to meet him at the threshold or beyond it; and did we choose any other portion we would be false to our history and traditions, recreant to our brothers' blood, which stained the hard fought fields of Virginia and Missouri, and unworthy of the high gift of independence sanctified by the blood of patriot martyrs.

This is not the hour for vain regrets or despondency. No, not even for hesitation. An insolent and powerful foe is already at the castle gate—the current of the mighty river speaks to us of his fleet advancing for our destruction, and the telegraph wires tremble with the news of his advancing columns. In the name of all most dear to us, I entreat you go meet him. A brave general, fellow-citizens, calls for you, and his patriot heart feels you will come. Laurels have already clustered around his brow, and he calls you to share with him new honors and new victories. Sacrifices must be made, but the recollection of them will nerve

your arm in the day of battle and make dearer your successes.

Fathers, husbands, brothers, lovers, your country calls you! Citizens, your property and your rights are in danger! Will you not go? The hour for glorious action is upon us; let it not pass unheeded by. Gen. Beauregard does his fellow-citizens the honor to wish them at his side in the hour of trial. A special messenger, member of his staff, Dr. Choppin, waits to return to him a glorious response. Upon volunteering you will be ordered to Gen. Beauregard, at Jackson, Tenn., and in a few weeks, when the necessity is past, you will return victorious, or leave your names as martyrs embalmed in our hearts.

THOMAS O. MOORE,  
Governor and Commander-in-Chief.

The address of the surgeon-general to the soldiers of New Orleans was as follows:

*Soldiers of New Orleans:*

You are aware of the disasters which have befallen our armies in the West. Greater disasters still are staring us in the face. Gen. Beauregard—the man to whom we must look as the saviour of our country—sends me among you to summon you to a great duty and noble deeds—invoking and inspired by the sacred love of country and of priceless liberty, he has taken the deathless resolution *de les venger ou de les suivre*. And with the immortal confidence and holy fervor of a soul willing, if need be, to meet martyrdom, he calls upon you to join him, in order that he may restore to our country what she has lost, and lead you on to glory and independence. In tones rigid and sullen as the tollings of the funeral knell, but with clarion accents that should send a quiver through every heart, and string the nerves of every man, he cries out the final refrain of that immortal hymn—

“Aux armes, citoyens! formez vos bataillons,  
Marchons!  
Marchons!

Qu'un sang impur abreuve nos sillons!”

Crecos of Louisiana, on to the work!

S. CHOPPIN,  
Surgeon-Gen. Beauregard's Staff.

February 25, 1862.

So urgent was the necessity, that, on the 28th of February, Gen. Beauregard thus addressed the governor:

JACKSON, Feb. 28, 1862.

I will accept all good equipped troops, under act of 21st August, that will offer, and for ninety days. Let the people of Louisiana understand that here is the proper place to defend Louisiana.

G. T. BEAUREGARD.

At the same time the regulations to govern the formation of the volunteer organizations were issued, of which the 18th is in these words: “Pikes and lances will be furnished by the State to all volunteer organizations not supplied with fire arms.” In every part of the Confederate States this scarcity of arms existed.

In New Orleans martial law was declared, and a provost martial appointed under the command of Gen. Lovell. All process for the ejection of the families of soldiers for the non-payment of rent was suspended. Steamboats were forbidden to take white men as deck hands, and required to discharge all who were engaged. No exemptions from military duty were allowed to any except minors, or persons of physical disability. Passports were required from all persons leaving the city. Foundries and workshops were required to furnish lists of workmen to whom exemptions were granted

for a certain number of days. The traffic in gold and silver against the notes of the Confederate States was prohibited. A tariff of prices was fixed for beef, pork, bacon, flour, bread, rice, corn, meal, peas, hay, oats, salt, &c., according to which all these articles were to be sold.

The effect of these efforts, and similar ones in Mississippi, Arkansas, and Tennessee, was to gather such a force under Gen. Beauregard as enabled him to check the Federal advance at Shiloh, and detain it before Corinth until the advance of the season and the low stage of the water in the rivers made their further progress impracticable until later in the year. Garrisons were kept up at the forts below New Orleans, and the city was put in a state of defence, which was believed to be sufficient to defy any attack. The preparations of the Federal Government for its capture, and the concentration of military and naval forces at Ship Island, were well known; but no real apprehensions were entertained of the success of that expedition. That these convictions of safety were not unreasonably sanguine is manifest from the fact that the history of military and naval affairs records no achievement so brilliant as the capture of New Orleans. (*See NAVAL OPERATIONS.*) The loss of this city, and the subsequent capture of the capital, Baton Rouge, placed so completely in the power of the Federal commander the important portion of the State, that there remained to the State Government little else than its name. Its troops were required by the Confederate Government elsewhere, and the military power which continued in the State was only sufficient for a force of observation, as to make an attack upon any unguarded or exposed Federal position.

On the 18th of June, Gov. Moore published an address to the people of the State, declaring what regulations should be observed by them relative to their enemies. This address closed as follows:

I am not introducing any new regulations for the conduct of our citizens, but am only placing before them those that every nation in war recognizes as necessary and proper to be enforced. It is needless, therefore, to say that they will not be relaxed. On the contrary, I am but awaiting the assistance and presence of the general appointed to the department to inaugurate the most effectual method for their enforcement. It is well to repeat them:

Trading with the enemy is prohibited under all circumstances.

Travelling to and from New Orleans and other places occupied by the enemy is forbidden. All passengers will be arrested.

Citizens going to those places, and returning with the enemy's usual passport, will be arrested.

Conscripts or militiamen, having in possession such passports, and seeking to shun duty under the pretext of a parole, shall be treated as public enemies. No such papers will be held as sufficient excuse for inaction by any citizen.

The utmost vigilance must be used by officers and citizens in the detection of spies and salaried informers, and their apprehension promptly effected.

Tories must suffer the fate that every betrayer of his country deserves.

Confederate notes shall be received and used as the currency of the country.



River steamboats must, in no case, be permitted to be captured. Burn them when they cannot be saved.

Provisions may be conveyed to New Orleans only in charge of officers, and under the precautionary regulations governing communication between belligerents.

The loss of New Orleans, bitter humiliation as it was to Louisianians, has not created despondency nor shaken our abiding faith in our success. Not to the eye of the enthusiastic patriot alone, who might be expected to color events with his hopes, but to the more unimpassioned gaze of the statesman, that success was certain from the beginning. It is only the timid, the unreflecting, and the property owner, who thinks more of his possessions than his country, that will succumb to the depressing influences of disaster. The great heart of the people has swelled with more intense aspirations for the cause the more it seems to totter. Their confidence is well founded. The possession by the enemy of our seaboard and main watercourses ought to have been foreseen by us. His overwhelming naval force necessarily accomplished the same results attained by the British with the same in their war of subjugation. The final result will be the same. Let us turn unheeding ears to the rumors of foreign intervention. To believe is to rely on them. We must rely on ourselves. Our recognition as a nation is one of those certainties of the future, which nothing but our own unfaithfulness can prevent. We must not look around for friends to help when the enemy is straight before us. Help yourself. It is the great instrument of national as of individual success.

THOMAS O. MOORE, Governor of Louisiana.

Opelousas, June 18, 1862.

For the state of affairs at New Orleans after the capture by the Federal forces, *see* NEW ORLEANS. For the further movements of the fleet after the capture of the city, *see* NAVAL OPERATIONS. For the capture of Baton Rouge, *see* ARMY OPERATIONS. Its evacuation took place August 16, by order of Maj.-Gen. Butler. On August 31 the village of Bayou Sara, in the parish of West Feliciana, on the Mississippi river, 165 miles above New Orleans, was fired upon and burned by the Federal gunboat Essex. The cause of this destruction was the firing from the town upon the gunboat, a method of annoyance and injury adopted by Confederate citizens along the shores of the river whenever steamboats passed. The Mississippi river from New Orleans nearly to Baton Rouge runs a nearly east and west course, and the tract of country between the river and the Gulf is probably the richest and most productive in the State. The New Orleans and Opelousas railroad runs a distance of 80 miles to Brashier. It contains the parishes of La Fourche, Terre Bonne, &c. A Federal force was sent from New Orleans to operate there under Gen. Weitzel. On the 26th of October he marched from Donaldsonville, which is on the right bank of the Mississippi, 82 miles above New Orleans, to Napoleonville, and bivouacked for the night. On the next day, about one mile above Labadieville, he encountered a Confederate force under the command of Col. J. P. McPheeters, with whom an action ensued, which lasted for half an hour, when the Confederate force were defeated and retired, leaving their colonel among the killed. Gen. Weitzel had eighteen killed and seventy-four wounded, and took 208 prisoners, seventeen of whom were wounded. His troops were the

8th New Hampshire, 75th New York, and 12th and 13th Connecticut, and 1st Louisiana regiments. No further resistance was made to his march to Thibodeaux, the capital of La Fourche Interior Parish. On the 9th of November all the property of this parish was confiscated by an order of Maj.-Gen. Butler. Citizens who had been loyal to the Government of the United States were to be secured in their rights of property. The plantations not confiscated were to be worked by hired negroes for the benefit of the United States.

The term of office of Gov. Moore expires on the 1st of January, 1864. The State is represented in the Confederate Congress by two senators and six members of the House. For the commerce of New Orleans in 1862, *see* COMMERCE.

LUTHERANS. The Lutheran Church, in the United States, consisted at the end of the year 1862 of 41 synods, 1,419 ministers, 2,672 congregations, and about 284,000 members. Two entire synods consist of Scandinavian (Swedish and Norwegian) churches, and a considerable portion of most of the others are made up of Germans. The following twenty-seven synods are united in a General Synod, which meets every second or third year: 1, New York, Ministerium; 2, Hartwick Synod (in the State of New York); 3, Synod of New Jersey; 4, Synod of Pennsylvania; 5, Synod of East Pennsylvania; 6, Synod of West Pennsylvania; 7, Synod of Central Pennsylvania; 8, Alleghany Synod; 9, Pittsburg Synod; 10, Synod of Maryland; 11, Melancthon Synod (Maryland); 12, Synod of Virginia; 13, Synod of Western Virginia; 14, Synod of North Carolina; 15, Synod of South Carolina; 16, Synod of Texas; 17, Synod of Kentucky; 18, English Synod of Ohio; 19, East Ohio Synod; 20, Wittenberg Synod; 21, Miami Synod of Ohio; 22, Synod of Northern Indiana; 23, Olive Branch Synod (Indiana); 24, Synod of Illinois; 25, Synod of Northern Illinois; 26, Synod of Southern Illinois; 27, Synod of Iowa, together with 862 ministers, 1,694 churches, and 162,298 members.

Three of these twenty-seven synods, viz., those of Virginia, North and South Carolina, have however declared their intention to secede from the General Lutheran Synod of the United States, and to form a General Synod of the Confederate States. The Synod of Texas was not represented at the last General Synod of the United States, but a letter was read from the delegate of the synod, stating that the Lutherans of Texas generally desired to remain loyal citizens of the United States, and loyal members of the General Lutheran Synod of the United States. There are also two Lutheran synods in Tennessee, the Tennessee Synod and the Holson Synod, mostly consisting of Germans, which were never in connection with the General Synod, but all the members of which, with a very few exceptions, were Union men, and not likely to enter into any connection with a General Synod of the Confederate States. The lead-

ing denominational organ in the Northern States claims moreover to have positive information that also in the churches of Virginia and South Carolina there is still a strong attachment to the Union, and they would resume their connection with the church of the United States as soon as the union of the States should be restored. The majority of the ministers and congregations of the three synods of Virginia, North and South Carolina, show themselves, however, determined to establish a permanent, independent organization. They have in operation at Charleston, South Carolina, a book establishment, and a new weekly organ, called the "Southern Lutheran," which is well patronized by the churches.

The General Lutheran Synod of the United States met, in 1862, at Lancaster, Penn., and was opened on May 1. About two hundred and fifty members of the church were present, representing twenty-two synods, the synods of Virginia, North and South Carolina, Texas, and Western Virginia having sent no delegates. The Rev. Dr. B. Kurtz, one of the oldest members on the floor of the synod, and a minister of the church for almost half a century, was elected president, and in his opening address referred briefly to some of the trials endured by the synod during the weakness of its infancy, about forty years ago, and the present extended and honorable position to which the body has since attained. Among the resolutions passed by the General Synod were the following:

*Resolved*, That it is the deliberate judgment of this Synod, that the rebellion against the constitutional Government of this land is most wicked in its inception, unjustifiable in its cause, unnatural in its character, inhuman in its prosecution, oppressive in its aims, and destructive in its results to the highest interests of morality and religion.

*Resolved*, That we regard this rebellion as more immediately the natural result of the continuance and spread of domestic slavery in our land, and, therefore, hail with unmixed joy the proposition of our chief magistrate, which has received the sanction of Congress, to extend aid from the General Government to any State, in which slavery exists, which shall deem fit to initiate a system of constitutional emancipation.

Some of the synods which are in connection with the General Synod regard the latter as unsound in doctrine, because not adhering with sufficient strictness to the old confession of faith, especially the Confession of Augsburg. This is, in particular, the case with the German synods of Missouri, Buffalo, and Iowa, and the two Scandinavian synods. These synods hold, however, no intercommunion with each other, and those of Missouri and Buffalo have even, on account of doctrinal differences, excommunicated each other. The (German) Synod of Iowa strictly adheres to the views of the Rev. Mr. Loehe, a prominent Lutheran minister of Bavaria, by whom the first congregation of the synod was established, and by whom nearly all of its ministers have been educated. This synod had, in 1862, 37 ministers, 50 congregations,

and about 5,000 communicants. It has no fellowship with any other part of the Lutheran Church of the United States, holds strict millenarian views, uses in the churches pictures and crucifixes, and at communion wax candles. Both the Germans and the Scandinavians receive every year large accessions to their number by the arrival of immigrants from Europe, and of late the churches in Germany and Scandinavia have begun to extend to them a more liberal support in the establishment of new congregations. As many of the immigrants live widely scattered, some of the western synods have appointed synodical itinerant preachers. Thus the German Synod of Michigan has a missionary, who stately preaches at fifteen settlements.

There are 6 theological seminaries, 8 colleges, 14 academies, and 10 female seminaries in connection with the General Synod, and 6 other institutions, not connected with the General Synod. One seminary (Newberry, S. C.), and 3 colleges, Roanoke College, at Salem, Va.; Newberry College, at Newberry, S. C., and North Carolina College, at Mt. Pleasant, N. C., are within the bounds of the seceded synods. Of the newspapers of the Lutheran Church, 6 are published in the English, 12 in the German, 1 in the Swedish, and 3 in the Norwegian language.

In the British possessions in North America the Lutherans have one synod, the Canadian Synod, with 12 preachers, 25 congregations, and 1,800 communicants. From the census of Canada taken in 1861, it appears that the Lutheran population has increased from 12,107 in 1852, to 25,156 in 1861, thus more than doubling in nine years. Of these 25,156 there were 857 in Lower Canada, and 24,299 in Upper Canada. In Upper Canada they form nearly 2 per cent. of the whole population. The increase is mainly from foreign emigration, and this is increasing rapidly from year to year.

In Germany, where the Lutherans originated, the church has lost a considerable portion of its members in consequence of the fusion of the Lutheran and the German Reformed Churches into the United Evangelical Church. This new denomination has replaced the Lutheran Church in Prussia, which had in 1861 a Protestant population of 11,278,780 in Baden, and in a number of other states. A considerable portion of the new denomination claims, however, to be still Lutheran, regarding their new church only as an external confederacy of the two old denominations; but it is impossible to ascertain its numerical strength. In Bavaria (Protestant population, in 1861, 1,280,000), Brunswick (269,000 Protestants), Hanover (1,640,000 Protestants), Mecklenburg (647,000 Protestants), Saxony (2,180,000 Protestants), Wurtemberg (1,159,000 Protestants), and several of the minor states of Germany, the great mass of the Protestant churches are still strictly Lutheran, but even there a struggle is constantly going on between the party which

wishes to adhere to the old landmarks of Lutheranism, and, in particular, to the symbolical books, and those who are desirous to abandon the strictly Lutheran character of the church. These movements are likely to affect ere long to a considerable degree the condition of all the Lutheran State churches. Where the voice of the laity has made itself heard, it has been in most instances in favor of abandoning the Lutheran character of the church. Many of the State churches have been, on this account, disturbed by an immense agitation, and none more so than the church of the kingdom of Hanover, where the Government, in union with the consistory of the capital, attempted the introduction of the catechism of Luther into the Lutheran schools of the kingdom, and raised thereby such an opposition, that at length it was deemed wiser to abandon all attempts at compulsion, and permit every congregation to introduce the catechism or not. In Prussia and the other States which have adhered to the United Evangelical Church, there are small independent Lutheran churches, which have seceded from the State churches, in order to maintain a pure Lutheran confession. This Free Church counts in Prussia a population of about 40,000 souls, but has recently split again into two parties, one of which favors the Presbyterian, and the other a Congregational form of Church Government. The Lutheran Church in Austria counts, according to the census of 1857, a population of 1,218,831 souls, but the great majority of the boards of the church do not acknowledge the obligatory character of the old confession of faith, and the synods of Hungary have declared in favor of a union with the Reformed Church.

In France the Lutheran Church, which there, as in Austria, is officially designated as the Church of the Confession of Augsburg, counted in 1862, 44 consistories, 229 parishes, 197 stations, 890 oratories, 658 schools, 261 official pastors, 86 vicars and chaplains. This church has been, during the year 1862, greatly distracted by a hot controversy between the orthodox and the liberal (Rationalistic) school. The latter school denies the inspiration of the Scriptures, and rejects the authenticity of a number of books of both Testaments. Their chief seat is Strasburg, where they are strongly represented in the theological seminary, and where they publish an able organ, the *Nouvelle Revue de Théologie*. The election of the editor of this review, Colani, as professor of the Theological Seminary, called forth a very animated literary controversy, and an earnest opposition on the part of several members of the supreme consistory, and the year 1862 closed without any abatement of the excitement prevailing in the Church.

In Sweden a dissatisfaction is spreading in the Lutheran State Church with regard to the servile condition in which it finds itself in rela-

tion to the State. A High Church paper has declared in the name of its party that if the church was unable to exclude the Rationalistic element, the High Churchmen would secede and organize an independent church. Many of the Evangelical clergymen envy the untrammelled position in which the Baptists and other free denominations find themselves, and are desirous of obtaining an equal freedom from the State. All the church press begins to give more attention to this subject, and a thorough change in the relation between Church and State is considered inevitable. The Government favors a change, and has laid before the Swedish diet a bill introducing certain reforms into the Church, and, in particular, providing for the regular convocation of General Church Synods.

Russia has a Lutheran population of more than three and a half millions. The members of the Lutheran Church, with the exception of the entirely Lutheran provinces in the northwest, some Lutheran colonies in the south and the large cities, are mostly so scattered that it is exceedingly difficult, if not impossible, for them to keep up their connection with the Church. Hundreds of thousands of members have thus been lost to Protestantism. To remedy this evil, a Church Aid Society was organized in 1859 by the General Consistory of the Lutheran Church, whose operations promise to be of importance to the future of Protestantism in eastern Europe and northern Asia. The central committee of the society, which has its seat in St. Petersburg, is supported by twenty district committees, extending through all the parts of the immense empire, and again embracing numerous branch committees. The following facts will convey some idea of the difficult task which the Church Aid Society has undertaken to perform. In the province of Ingria there are 10,808 children of the age to attend a school, but only 1,198 receive instruction in 10 parochial and 6 Sunday schools. The Lutheran parish of Novgorod extends over a territory larger than the aggregate area of Sweden and Norway; it has 2,088 members, and only 2 schools. In the governments (provinces) of Vladimir, 1,182 manufactories employ 80,000 workmen, a majority of whom are Lutherans. But it was not until February, 1859, that the first Lutheran congregation of the province was organized. The district of the committee of Moscow embraces also West Siberia, which has only two Lutheran parishes, Tobolsk with 829 souls, and Tomsk with 168 souls. All East Siberia, a country equal in extent to about five sixths of Europe, has only one Lutheran congregation, at Irkutsk. The number of Lutherans in this parish, as far as they are known, is 1,086, and to see them all the pastor has had to travel during the past four years 60,000 versts, one verst being about two thirds of an English mile.

## M

**MACKENZIE**, Rt. Rev. Bishop, died in Central Africa, Jan. 31, 1862. He was born at Hareus-cottage, Peebleshire, April 10, 1825, studied at the Edinburgh Academy and at Dr. Cowan's Grange school, near Sunderland. In 1844 he entered St. John's College in the University of Cambridge, where he remained only two terms, and then removed to Gonville and Caius College, where he graduated with honor in 1848. Soon after taking his degree he was elected to a fellowship and ordained by the Bishop of Ely. He resided in the college as a lecturer until 1854, and during this period exercised a wider influence in the university than any man of his age had ever done previously. His thoughts were first turned to the mission field of labor by a sermon of the apostolic Bishop of New Zealand, and in the autumn of 1854, he went out to Natal as archdeacon of Pieter-Maritzburg under Bishop Colenso, where he remained nearly five years, maintaining himself at his own charges and applying his stipend to the support of another clergyman in the colony. In 1859 he returned to England in order to offer himself for more directly missionary work among the Zulu Cafres; but circumstances rendered it desirable to defer the establishment of the mission; meanwhile Dr. Livingstone had been in England, and urged upon the Universities of Oxford and Cambridge the necessity of establishing a mission somewhere in the centre of Southern Africa. Committees had been formed for this purpose, and upon the failure of the Zulu Mission, Archdeacon Mackenzie, being at liberty, accepted the offer of a place at the head of the mission, and in 1859 and during the 11 months following was engaged in collecting the requisite funds from England, Scotland, and Ireland. In Oct. 1860, he set forth upon his enterprise with a small company of missionaries, lay and clerical, and Jan. 1, 1861 was consecrated bishop by the Metropolitan of Capetown. On Jan. 5, he sailed for the Zambesi, and after some necessary explorations settled at a village named Magomero, where his labors commenced but were speedily closed by his untimely death.

**MAINE**, the most northeastern and the most maritime of all the States of the Federal Union, has increased in population during the ten years preceding 1860 the number of 45,110. For further statistics of the census relative to the State of Maine, *see* UNITED STATES.

The citizens of Maine were divided into three parties at the election which took place on the second Monday in September. The object of the election was to choose State officers, members of Congress, and members of the State Legislature. The governor and Legislature are chosen annually. On the 5th of June a convention of the republican party as-

sembled at Portland, over which Sydney Benham, of Paris, presided. The convention nominated Abner Coburn as their candidate for governor, and adopted a series of resolutions, in substance as follows: "First, inviting the patriotic citizens of Maine to unite on a simple basis to support the policy and principles characterizing the Administration of Abraham Lincoln; second, that the rebellion must be put down at any cost; third, expressing sympathy with, and praise of the American army and navy, and approving national and State measures for their relief and reward; fourth, expressing respect for and confidence in the present governor, Mr. Washburne; fifth, expressing confidence in the Hon. Abner Coburn, the nominee for governor."

The convention of the second party, designated as "war democrats," assembled at Bangor, on the 26th of June. Francis G. Butler, of Farmington, presided. The convention nominated Col. Charles D. Jameson for governor, and adopted the following resolutions:

*Resolved*, That it is the first duty of the citizen, in this perilous national crisis, to yield a ready, unwavering support to the Government in all necessary and proper efforts to subdue the existing rebellion and vindicate the authority of the Constitution and Union over every inch of territory in the United States.

*Resolved*, That our army and navy are entitled to the warmest gratitude and support of every citizen for their self-sacrificing efforts in behalf of our common country, and that we will resist all measures and efforts to convert this war for the Union into a crusade for negro emancipation.

*Resolved*, That we cordially invite all citizens of this State, who concur with us in the foregoing declaration of sentiment, to unite with us in the elevation of men to official place who will act in accordance with these sentiments.

*Resolved*, That we cordially approve of the patriotic course of the brave Gen. McClellan; that we admire his genius and skill as commander of our army, and that our whole hearts are interested in his success before Richmond. That we view with detestation and scorn the wicked attempts of scheming politicians to undermine and weaken him and his army in their brave efforts for the vindication of the Union.

A motion was made in the convention to declare Col. Jameson nominated without a ballot, which met with so much opposition from the friends of another candidate, Bion Bradbury, that the ballot was taken, and resulted in 160 votes for the former, and 107 votes for the latter. Mr. Bradbury, who had failed to receive the nomination at this convention, was afterward nominated as a candidate for governor by the regular democratic party, which held its convention at a later day. This convention assembled at Portland on the 14th of August. Luther S. Moore, of York county, presided. The following resolutions were adopted:

*Whereas*, The American Constitution was ordained and established by our fathers in order to form a more perfect Union, establish justice, ensure domestic tranquillity, provide for the common defence, promote the

general welfare, and secure the blessings of liberty to posterity, therefore

*Resolved*, That the purpose of the Democratic party is the restoration of the Union as it was, and the preservation of the Constitution as it is; and to secure these objects we will stand shoulder to shoulder with Union men everywhere in support of the Federal Government, in maintaining its safety, integrity, and legitimate authority by all constitutional and proper means.

*Resolved*, That the Constitution was first formed and adopted by the States and the people, in a spirit of concession and compromise, and the Union resulting from its adoption has hitherto been preserved by the same means, and must from its very nature, and the principles upon which our institutions are founded, still rely mainly for its continuance or restoration, upon the prevalence among the people of the same spirit by which it was formed, and not upon military power alone. That we hold sacred, as we do all other parts of that instrument, the following provisions of the Constitution of the United States :

[These provisions relate to the trial by jury where the crime was committed; the abridgment of the freedom of speech and the press; the reserved power of the States and people; the right of the people to be secure from unreasonable searches and seizures; the right of the accused to a speedy public trial where the crime was committed.]

And we utterly condemn and denounce the repeated and gross violation by the Executive of the United States, of the said rights thus secured by the Constitution; and we also utterly repudiate and condemn the monstrous dogma that in time of war the Constitution is suspended, or its powers in any respect enlarged beyond the letter and true meaning of that instrument. That we view with indignation and alarm the illegal and unconstitutional seizures and imprisonment, for alleged political offences, of our citizens without judicial process, in States where such process is unobstructed, but by Executive order by telegraph or otherwise, and call upon all who uphold the Union, the Constitution, and the laws, to unite with us in denouncing and repelling such flagrant violation of the State and Federal Constitutions and tyrannical infraction of the rights and liberties of American citizens; and that the people of this State cannot safely, and will not submit to have the freedom of speech and freedom of the press, the two great and essential bulwarks of civil liberty, put down by an unwarranted and despotic exertion of power.

The election was held on the 8th of September, and the votes were cast as follows:

The republican candidate received.....	45,584
The "war democratic" candidate received....	7,178
The regular democratic candidate received...	32,331
The republican majority over both the others was .....	6,025

The majority of President Lincoln over all other candidates, in 1860, was 24,704.

The vote in the congressional districts was as follows:

	Republican.	Democrat..	War Democrat.
1st.....	10,205	10,332	
2d .....	9,392	7,237	
3d .....	9,971	6,549	
4th.....	8,118	3,976	1,290
5th.....	9,160	8,217	

The Legislature was elected as follows:

	Senate.	House.
Republicans .....	24	107
War Democrat.....	3	12
Democrats .....	3	32

The force sent into the field from the State of Maine for the war was twenty-seven regiments of infantry, one regiment of cavalry, one regiment of mounted artillery, six batteries, and one company of sharpshooters, exceeding thirty thousand men. These troops were distributed in Virginia, on the peninsula, and southwest of Washington, at Port Royal in South Carolina, Fernandina and Pensacola, Florida, and at New Orleans.

An event of considerable interest to the people of the State, and one also of national importance, occurred at the beginning of 1862. This was the permission granted by the Secretary of State, Mr. Seward, for British troops to pass across the territory of the State. Just previously, the seizure and removal of Messrs. Mason and Slidell from on board the British steamer Trent had been made, and the British, in connection with their demand for the release of these persons, were sending large numbers of troops to Canada. On the 13th of January the senate of the State adopted a resolution requesting the governor to inquire if such permission had been given. Mr. Seward replied on the 17th, stating that on the 4th of January his department was advised by a telegraphic despatch from Portland, in the State of Maine, that the steamship Bohemian, due there on the 7th, was telegraphed off Cape Race, with troops for Canada; and inquiring whether, in case they came to Portland, any different course was to be taken than what has been heretofore pursued, and asking instructions, in that contingency, by telegraph.

Upon this information he replied by telegraph, addressed to the marshal of the United States, and all the Federal officers in Portland, directing that the agents of the British Government shall have all proper facilities for landing and conveying to Canada, or elsewhere, troops and munitions of war of every kind, without exception. The immediate grounds for this proceeding were, that it was supposed that a passage of the troops and munitions named across the territory of the United States, by the Grand Trunk railroad, would save the persons concerned from risk and suffering, which might be feared if they were left to make their way, in an inclement season, through the ice and snow of a northerly Canadian voyage.

The principle upon which this concession was made to Great Britain was that, when humanity, or even convenience, renders it desirable for one nation to have a passage for its troops and munitions through the territory of another, it is a customary act of comity to grant it, if it can be done consistently with its own safety and welfare. It is on this principle that the United States continually enjoy the right of the passage of troops upon the Panama railroad across the territories of the republic of New Granada.

It was not supposed that the State of Maine would feel aggrieved; but if it was so, the directions would be modified.

The principal institutions for education in the State consist of Bowdoin College at Brunswick, and the college at Waterville, a theological seminary at Bangor, and a medical school at Brunswick. The number of common school districts making returns to the superintendent was 4,151, and 360 reports of districts. The average attendance at these schools is 110,969, and the number between the ages of 4 and 21 years is 249,061. The amount of the public school fund is \$154,700, and the amount raised by taxation for the year ending December, 1861, was \$478,017. There are in addition seminaries or academies in a large number of towns.

The geological survey of a portion of the State, which was commenced in 1861, has proceeded so far in the exploration and examination of the new lands belonging to the State, as to report the discovery of gold and copper, lead, tin, and iron ores, the latter of which in some localities is of excellent quality; also quarries of slate and marble. The climate of Aroostook county is reported by them to be warmer than in some portions of the State farther south.

The railroads in operation and projected within the State reach 592 miles. Those in operation in 1860 amounted to 472 miles, at a cost of construction of \$16,576,385.

The debt of the State is small, being about \$2,000,000. The wild lands which belong to Maine are valued above this amount.

MANSFIELD, JOSEPH KING FENNO, a brigadier-general in the United States army, born in New Haven, Conn., Dec. 22, 1803, was killed at the battle at Antietam, Sept. 17, 1862. At the age of fourteen he received a cadet's appointment, and entered the military academy at West Point, where he distinguished himself in military studies, passing through every grade of office in the cadet battalion, and during a portion of the fourth year acted as assistant professor in the department of natural philosophy. He graduated in 1822, standing No. 2 in a class of forty members, and was made a second lieutenant of the corps of engineers. For the next two years he was an assistant to the board of engineers, then assembled in New York, and engaged in planning fortifications for the defence of the harbors and cities on the coast. In 1832, he was promoted to be a first lieutenant, and for a few years following was engaged upon the construction of Fort Pulaski, though in the mean time occasionally being detached upon duty at other posts. On the 7th of July, 1838, he was appointed captain. He served in the Mexican war as chief engineer, under Gen. Taylor, was brevetted major for gallant and distinguished services in the defence of Fort Brown, Texas, in 1846, and, the following September, was brevetted lieutenant-colonel for gallant and meritorious conduct in the battles of Monterey, where he received no less than seven severe wounds. In 1847, he was brevetted colonel for his meritorious ser-

vices at Buena Vista. On the 26th May, 1853, he was appointed an inspector-general of the United States army, with the rank of colonel, which position he held at the breaking out of the present war. In May, 1861, he was commissioned brigadier-general, and was placed in command of the department of Washington. He fortified the city on every side, crowned the heights of Arlington with earthworks, and took Alexandria. Upon the return of Gen. Wool to Fortress Monroe, he was sent to Hatteras, and afterward to Camp Hamilton and Newport News. On the 10th of May he marched, with a division, to the attack on Norfolk, and, after the capture of that place, was assigned to the command of Suffolk, Va., where he acted as military governor. After the second battle of Bull Run, he was summoned to the court of inquiry at Washington, and, during the delay, becoming impatient for active duty, he was assigned to the command of the corps formerly under Gen. Banks, and, at the battle of Antietam, fell mortally wounded, while cheering on his troops in a brilliant charge.

MARYLAND, the most northeastern border slave State except Delaware, increased in population from 1850 to 1860 the number of 104,015 persons. The further details of the census of 1860, relative to Maryland, will be found under UNITED STATES.

The Legislature of Maryland at its last session, in 1861, ordered inquiries to be made of the governor of Massachusetts relative to the families of the soldiers of the latter State who lost their lives at Baltimore during the riot there on April 19, 1861. (See ANNUAL CYCLOPÆDIA.) The inquiry was made with a view to provide relief for those families. This called forth the following reply from the governor of Massachusetts:

COMMONWEALTH OF MASSACHUSETTS, EXECUTIVE DEPARTMENT, BOSTON, Dec. 25, 1861. }

Hon. John V. L. Fendley, Chairman of the Committee on Militia of the House of Delegates of Maryland:

MY DEAR SIR: It is with feelings which I will not attempt to express that I have received, on this anniversary day, your letter addressed to me from Annapolis.

I have immediately addressed the mayors of the cities of Lowell and Lawrence on the subject of your inquiries, and hope to be able to transmit their answers at an early day.

The past cannot be forgotten, but it can be forgiven; and in the good providence of God, I believe that the day is not distant when the blood that was shed at Baltimore by those martyrs to a cause as holy as any for which sword was ever drawn, shall be known to have cemented in an eternal union of sympathy, affection, and nationality the sister States of Maryland and Massachusetts.

With sincere respect, I have the honor to be, faithfully and respectfully, yours,  
JOHN A. ANDREW.

Upon receiving the information desired, at the subsequent session, the Legislature appropriated seven thousand dollars for the relief of the families of those who were killed and wounded on that occasion.

This appropriation was made at the regular

session, convened on the first Wednesday of January. At this session Gov. Hicks sent in his final message, as his term of office had expired, and was succeeded by Augustus W. Bradford, who was inaugurated on the 8th as governor for the four ensuing years. The position of Maryland at this time, relative to the troubles of the country, is very clearly indicated in the following remarks in his inaugural message, by the new governor, who was elected by a majority of 81,412 :

The leaders of the rebellion may assert over and over again that the South never will submit to this national rule—that it will resist to the last the proposed reunion. So far as those leaders are concerned, we may not doubt the sincerity of their protest; their offences against free institutions are too rank and too recent to allow them willingly again to submit to the will of the majority. But to say nothing of that popular voice which they have for the present stifled, to admit, for argument sake, that but one sentiment pervades the entire South, and that it clamors for a separate Government; earnest as that purpose may be, there is a still stronger force opposed to it, not merely the force of a vast numerical superiority, but a power made irresistible by the force of necessity; a controlling and decisive power, growing out of the demands which the laws of self-preservation make imperative. Nationality with us therefore is a necessity, and peace, anxiously as we may await it, can never come until that necessity is recognized, and our whole country once more united under its old established rule. Who can doubt that such will be the ultimate result of the war if it is confined to the faithful pursuit of that object?

This was still further shown by the following resolutions, adopted by the Legislature, and presented in the U. S. Senate on January 2 :

*Resolved by the Senate and House of Delegates of Maryland,* That the Constitution of the United States, so admirably framed by the wisdom of our forefathers, is recognized by the people of Maryland as the charter of their liberties—the foundation, support, and protection of their rights, and the main source of all their prosperity; that they are at all times ready cordially to renew the expression of their devotion to its principles; that they unreservedly acknowledge the supremacy of all laws made in pursuance thereof, and repudiate every construction of that instrument which would destroy its efficiency, its very existence, indeed, by the assertion of any right expressed, implied, or reserved in the States to secede from the Union; and though they consider the right of revolution, for justifiable cause, inherent in every people, they unhesitatingly declare that they know no existing cause to justify the people of the United States in attempting the overthrow of their Government.

2. *Resolved,* That the duty and interest of the people of Maryland alike forbid that they should take part in the infatuated and suicidal rebellion which now seeks to separate the States of this Union, and to destroy that great nationality which has made us prosperous at home and respected abroad, which separation, if accomplished, must result in the most serious disaster to all the States, but from the peculiarity of our geographical position, can bring to our own State nothing but irretrievable ruin.

3. *Resolved,* That the present unhappy and fratricidal war has been forced upon the Government of the United States by the seditious and unlawful acts of those who have attempted its overthrow by violence, and the State of Maryland will cheerfully contribute her proportion of men and means to sustain the nation in its struggle for existence so long as the war is conducted in accordance with the principles of the Constitution, and so long as the purpose of those in power

is the maintenance of the Union, with the rights guaranteed by the States unimpaired.

4. *Resolved,* That the loyalty of the people of Maryland to the General Government, established by the Constitution, is untouched by any shade of servility, and they must ever regard with extreme jealousy all attempts, from whatever quarter, to make the present war for the restoration of the Union the means of interfering with the domestic institutions of the States; and they solemnly protest against all schemes, the object or tendency of which is to excite insurrection among the slaves, declaring the same illegal, and calculated, if put in practice, to produce results too horrible to contemplate.

5. *Resolved,* That this Legislature is gratified to know that the true principles on which the war should be conducted have been expressed in most emphatic language by both houses of the present Congress in their extra session of July last; that they have been declared by the President in his latest message, and that they have been conspicuously illustrated in the proclamation of Gen. Dix to the people of the eastern shore of Virginia.

6. *Resolved,* That although in the immediate presence of armies, when war or insurrection exists, it cannot be expected that the civil power should at all times maintain its supremacy, and there may be cases of extreme necessity, where the safety and preservation of the Government would excuse a resort to extraordinary measures, yet the dangers of a departure from the forms of law, which are the protection of the individual rights, should never be forgotten, and all irregular proceedings should be abandoned as soon as it is clear that the extreme necessity which gave rise to them has passed away.

7. *Resolved,* That the people of Maryland do not hesitate to express their approval of the course and policy of the President in the conduct of the war thus far, as exemplified by his official acts, and they hereby tender him their thanks for the earnest desire he has manifested to avert from them the immediate horrors and calamities of civil war; assured by his firmness and honesty in the past, they confidently expect that, in spite of the importunities of pernicious fanatics, he will keep steadily in view his sworn duty to preserve, protect, and defend the Constitution of the United States.

The views of the people of the State, as indicated by the opinions of the governor and Legislature, were strongly in favor of sustaining the Government and the Union. The system of aiding the families of volunteers was adopted by the Legislature, and many other measures relating to the internal affairs of the State under the circumstances in which it was placed.

The introduction before Congress, and the adoption of an act to emancipate the slaves in the District of Columbia, was very repugnant to the people in the adjacent counties of Maryland. A large meeting of these of Montgomery county assembled at Rockville about the first of April, and passed a series of resolutions declaring that the measure was regarded as the entering wedge to a scheme of general emancipation, a violation of public faith, unconstitutional, as taking private property not for public use, nor for a just compensation, unwise, ill-timed, both politically and financially. The action of Congress was, however, acquiesced in.

The attachment to the Union which has existed in the State of Maryland, and which has been manifested most amply during the past

year, places her in the front rank of all the States devoted to that cause. Together with Kentucky, this State held the balance of power between the two hostile sections when the war commenced, and if they had failed in taking the stand they did take against disunion, the capital of the nation would inevitably have been lost, and the Union cause compromised, perhaps hopelessly, in the estimation of foreign nations.

The supremacy in the physical contest with these two States firmly united with the Southern States, so far as to have secured a return of the seceding States, would have been so doubtful and demanded such years of contest as to have discouraged the most sanguine. It was the belief of the Government and people of the Confederate States that Maryland would unite with the Confederacy, if she was supported to maintain the contest that would follow within her borders. As the divisions of Gen. Lee's army crossed the Potomac, deficient in supplies of every kind, they were expecting to be received into a land of plenty, and to be joined by the brave soldiers of that State. In less than fifteen days their weary feet recrossed the same river retreating from a victorious foe. No great popular welcome had met them; their thinned ranks had not been filled by new recruits, and no tokens of substantial sympathy had been shown. At every step as they advanced they found themselves in an enemy's country. Yet the State of Maryland could not approve of many of the great measures of the Government, which were destined to destroy some of her most cherished institutions, neither was the administration one with which she had the smallest sympathy. Such were the circumstances in which she was placed and such the heroic patriotism she displayed amid them.

The details of the advance of the Confederate troops into Maryland will be found under **ARMY OPERATIONS**, to which the reader is referred.

Upon the call of President Lincoln for three hundred thousand men, an enrolment of all the citizens of the State subject to military duty was made by the order of Governor Bradford. Preparatory to this draft for soldiers, committees were appointed by the governor in every county, nearly all of whom upon investigation recommended such draft as both necessary and proper to complete the quota of the State. The draft was in due time carried into effect and sustained by the people. The places of a large number of those drafted were subsequently filled by substitutes. In Baltimore, Harford, and Prince George counties, and Baltimore city, the complement was thus made up. The bounties required to be paid were from \$225 to \$275, and not higher than in any Northern State. In Massachusetts the quota of the second call was not even made up by a draft. The quota of Maryland under the first call was eight thousand five hundred and thirty-two, of whom about one third were to come from the city of Balti-

more. At the time the number of men liable to the service in the city was seventeen thousand. The quota under both calls was about sixteen thousand, and the proportion of Baltimore about five thousand six hundred.

The number of miles of railroad within the State is 422, of which the cost of construction has been \$46,265,634. The canals of the State are the Susquehanna and Fishwater, 45 miles; Chesapeake and Ohio, 184 miles; Chesapeake and Delaware, 12 miles.

Maryland contains a number of excellent institutions for education. There are four in the city and county of Baltimore. Others are at Annapolis, Ellicott's Mills, Chestertown, and Frederick. The State has a school fund amounting to nearly \$350,000, and the public expenditure for schools exceeds half a million. The system of public schools in operation in Baltimore is hardly surpassed by those of any other Northern city.

The arrest of citizens without legal process continued to be carried on to a greater extent in Maryland than any other State. The following instance is an illustration. On the 28th of July a large Union mass meeting was held in Baltimore, at which a resolution was adopted to appoint a committee to investigate certain charges of disloyalty and official corruption. On Oct. 28, a meeting of the vice presidents of the original meeting was called to hear a report of this committee. The committee reported that they had summoned a large number of persons to testify in regard to these matters, and taken ninety-six affidavits of respectable men proving an enormous amount of disloyalty on the part of persons in position; that they had prepared a brief of the evidence, which, with the affidavits, they had laid before the president. That owing to preoccupation no action had been taken on the papers, which were afterward at their request returned. Before the report of the committee was concluded the meeting was broken up by the sudden appearance of Major Jones and other officers of Gen. Wool's staff, and a company of soldiers, who seized upon the documents exposing official corruption and arrested the members of the committee then present, viz.: Thomas H. Gardner, clerk of the criminal court; Col. Thomas R. Rich, aid to the governor; Alfred Evans; and Thomas Sewell. The prisoners were sent to Fort Delaware, but afterward unconditionally released.

**MASSACHUSETTS**, the 30th State in the Union in area, ranks in population as the seventh, the census returns of 1860 showing that her total number of inhabitants was 1,231,066, of whom 596,718 were males, and 634,353 females, and 9,602 colored. In density of population and absolute increase of population per square mile she ranks first, and in the amount of her manufactures, third. The aggregate products of the latter amounted to \$266,000,000, of which \$55,875,684 were cotton and woollen goods, and the products of her fisheries to \$9,300,402. In



1862 the State had about 1,550 miles of railroad in operation, or under construction, in which upward of \$60,000,000 have been invested. The total value of her real and personal property amounted to \$815,237,433, which was exceeded by that of only 4 other States. The number of newspapers and periodicals published in the State was 232, and their aggregate circulation was 102,000,760 copies. (*See UNITED STATES.*)

In January, 1862, the Legislature met and organized, by the choice of John H. Clifford, as president of the Senate, and Alexander H. Bullock, as speaker of the House of Representatives, both being the candidates of the republicans, who were in a large majority. John A. Andrew was at the same time inaugurated as governor of the State, a post which he had filled during the previous year. The amount of debts and liabilities of the State was stated to be \$10,983,345.56, of which \$1,368,000 were floating, and the remainder funded debt. The resources amounted to \$14,835,161.27, of which \$3,205,744.98 were unproductive, leaving a surplus over the liabilities of the State of \$3,846,241.62.

One of the first acts of the Legislature was to provide for the protection of the chief seaports of the State in the event of a foreign war, without waiting for the tardy and uncertain action of the National Government, from which however a reimbursement for moneys expended was expected. A resolution was accordingly adopted as follows:

That his Excellency, the Governor, by and with the advice and consent of the council, be and he is hereby authorized to enter into contracts on behalf of the Commonwealth for the manufacture of suitable ordnance for the coast defences of Massachusetts, to an amount not exceeding five hundred thousand dollars, after advertising for proposals therefor; provided, that the work shall be done under the supervision of officers to be appointed by the Government of the United States.

In accordance with this resolution the armament of the fortifications in Boston harbor and at New Bedford, was put on a war footing, and plans were prepared by the engineer and ordnance officers of the State, for the fortification of other ports in Massachusetts, by earth works to be thrown up in a few days, in cases of necessity.

The following resolutions reported by the Committee on Federal Relations were adopted on April 30, in relation to the act passed by the General Assembly of Maryland for the relief of the families of the killed and wounded of Massachusetts at Baltimore, on the 19th of April, 1861:

*Resolved*, That the Commonwealth of Massachusetts hereby acknowledges the liberal appropriation of her sister State of Maryland, for the relief of the wounded, and of the families of the killed of the Sixth regiment of Massachusetts volunteers, in the lamentable occurrences at Baltimore on the 19th of April, 1861. The people of Massachusetts will welcome with sincere and cordial satisfaction this evidence of the generous sympathy of the people of Maryland, which will tend to restore and strengthen that kind of fraternal feeling which

should ever exist between the citizens of the different States of this Union.

*Resolved*, That his Excellency, the Governor, be requested to transmit a copy of this resolve to his Excellency, the Governor of Maryland, with the request that it be laid before her Legislature at its next session.

On Jan. 1, 1862, Massachusetts had sent to the field (including 3,736 three months' volunteers) 33,636 men, and had also contributed 11,000 men to the navy. Six months later she had in actual service 26 regiments of infantry, 1 of cavalry, 1 of heavy artillery, 8 batteries of light artillery, and 2 companies of sharpshooters, beside 3 additional regiments in process of recruitment, all of which were enlisted for three years; and the number of seamen for the navy furnished by her was estimated at from 12,000 to 18,000.

On May 19th the U. S. adjutant-general telegraphed from Washington to Gov. Andrew, requesting to know how soon he could raise and organize three or four more infantry regiments, and have them ready to be forwarded, armed and equipped, to the seat of war. The governor, in reply, sent the following communication to Secretary Stanton:

A call so sudden and unexpected finds me without materials for an intelligent reply. Our young men are all preoccupied with other views. Still, if a real call for three regiments is made, I believe we can raise them in forty days. The arms and equipments would need to be furnished here. Our people have never marched without them. They go into camp while forming into regiments, and are drilled and practised with arms and muskets as soldiers. To attempt the other course would dampen enthusiasm, and make the men feel that they were not soldiers but a mob.

Again: if our people feel that they are going into the South to help to fight rebels who will kill and destroy them, by all means known to savages as well as civilized men; will deceive them by fraudulent flags of truce and lying pretences, as they did the Massachusetts boys at Williamsburg; will use their negro slaves against them both as laborers and fighting men, while they themselves must never fire at the enemy's magazine, I think they will feel the draft is heavy on their patriotism. But if the President will sustain General Hunter, and recognize *all* men, even black men, as legally capable of that loyalty the blacks are waiting to manifest, and let them fight with God and human nature on their side, the roads would swarm, if need be, with multitudes whom New England would pour out to obey your call.

Always ready to do my utmost, I remain, most faithfully, your obedient servant,

JOHN A. ANDREW.

A few days later came the intelligence of the sudden march of the Confederate Gen. Jackson down the valley of the Shenandoah, and of the retreat of Gen. Banks's small army and the imminent danger apprehended at Washington. The northern and eastern States responded with eagerness to the call of the Government for aid, and among the first to take active measures in that behalf was Gov. Andrew, who, forgetting the scruples which he had urged in his previous communication, issued a proclamation. (*See page 108.*)

With an alacrity which rivalled that of their ancestors, the "minute" men of the Revolution, the citizens of Massachusetts responded at once to the call of the governor, and on the suc-

ceeding day, May 26, 3,100 men reported to him at his headquarters on Boston Common. These were the regular militia of the State, and did not embrace a regiment of volunteers despatched on the same day to Washington. It was noted with gratification that this was double the number which reported in April, 1861, immediately after the fall of Fort Sumter, and claimed that Massachusetts was still among the first of the States in devotion to the Union as well as in resources.

Within a few days the retreat of Gen. Jackson relieved the General Government of fears for the safety of the capital, and in accordance with orders from the War Department the militia were released, and all future enlistments were directed to be made for 3 years or during the war.

The calls of the Government in July and August for additional three years' men and 800,000 nine months' men were responded to by Massachusetts with her accustomed readiness, and by the 18th of December out of the 75,294 men, which constituted the quota of the State to that period, all but 3,809 had been furnished. By the report of the adjutant-general rendered at the commencement of 1863, it appears that subsequent to July, 1862, the State sent 15,012 men for the three years' service and 22 regiments, comprising 19,806 men, for 9 months, and that during 1862 6,628 men had been recruited to fill up the ranks of the old regiments in the field. If to these be added the men recruited for the navy, a total of about 90,000 men enlisted since the commencement of the war will be entered to the credit of the State. These amount to about 64 per cent. of the total number of non-exempts enrolled by the State officers, and .073 of the whole population. The aggregate number of soldiers in service at the close of the year was estimated by Gov. Andrew at 60,000.

In connection with the subject of the equipment of the Massachusetts regiments, in which upward of \$4,000,000 had been expended under the direction of the executive, it may be added that a legislative committee, which had been invested with absolute authority to investigate the matter, reported unanimously that after a thorough examination, in which they had even advertised in the public journals "that they were holding meetings for the purpose of receiving such complaints as any person might be desirous of making concerning any contracts," they had been "unable to fix a charge of fraud or improper conduct upon any person connected with the Government," that they had no complaints before them which remained unexamined, and that they had no reason to suppose that any more would or could be preferred.

In the early part of September the political parties began to organize for the November election of State officers and members of Congress. A convention of the republicans nominated Gov. Andrew and his colleagues in office

for reelection, and adopted the following resolutions:

*Resolved*, That Massachusetts with all her heart and strength will support the Government of the United States in the prosecution of this war, by the employment of all the means sanctioned by the usages of Christian civilized warfare.

*Resolved*, That the most decisive measures for the complete and permanent suppression of this rebellion are the most prudent, and that, as the institution of slavery is a principal support of it, that institution shall be exterminated.

*Resolved*, That we heartily applaud the gallantry and endurance of our soldiers, and mourn the loss of those who have fallen, and that we will cherish their memories in our hearts and preserve them by most enduring monuments.

*Resolved*, That we recognize and acknowledge the preëminent merits and services of our Senators in the Congress of the United States, the honorable Charles Sumner and the honorable Henry Wilson. In the posts of duty assigned them by the suffrages of their brother Senators, one as Chairman of the Committee on Foreign Relations and the other as Chairman of the Committee on Military Affairs, they have cordially and unreservedly, and with masterly ability, supported all governmental measures, and fitly represented the Commonwealth as among the most cheerful and enthusiastic defenders of the Government. And now that the second term of our senior Senator is drawing to a close we desire to express our warm approbation of his course and appreciation of his services, and to commend him to the suffrages of his fellow-citizens, whom he has served so well, that the Commonwealth may again honor itself by returning to duty at the capital a statesman, a scholar, a patriot, and a man of whom any Republic in any age might be proud.

*Resolved*, That the administration of the affairs of the State during the past year, and the intelligent and energetic manner in which its Chief Magistrate and other officers have discharged their severe duties, merit and receive our most hearty commendation.

On the 18th of September, a call signed by many eminent citizens of Massachusetts was issued for a convention of delegates from the people to meet at Boston on Oct. 7. The purpose of the call was thus stated:

In order, therefore, that the loyal men in Massachusetts may in the most effectual manner sustain and support the Government, the Constitution and the laws, and aid the chosen and constituted head of the nation, the President, in his patriotic and self-sacrificing labors to save the country and put down rebellion, we ask the people of this Commonwealth, irrespective of all party, to meet at some future time to be agreed upon, to nominate candidates for State officers at the coming election, and take counsel together for the common weal.

The convention assembled at the appointed time at Faneuil Hall, which was filled with delegates and friends of the movement. Linus Childs was appointed president of the convention, and the following nominations were made: for governor, Charles Devens, jr.; lieutenant-gov., Thomas F. Plunkett; secretary, Oliver Warner; treasurer, Henry K. Oliver; attorney-general, Henry W. Paine.

The views of the convention were expressed by the following resolutions:

*Resolved*, That our sentiments are clearly expressed by adopting the language of the following resolution passed by Congress at the extra session in 1861:

"That the present deplorable civil war has been forced upon the country by the disunionists of the Southern States, now in arms against the Constitutional Government, and in arms around the capital; that in this great

national emergency, banishing all feeling of mere passion and resentment, we will recollect only our duty to the whole country; that this war is not waged on our part in any spirit of oppression, or for any purpose of conquest or subjugation, or purpose of overthrowing or interfering with the rights or established institutions of those States, but to defend and maintain the supremacy of the Constitution, and to preserve the Union with all the dignity, equality, and rights of the several States unimpaired, and that as soon as these objects are accomplished the war ought to cease."

*Resolved*, That the expenditure of nearly two thousand millions of treasure, the loss of two hundred thousand men of our armies in a war of eighteen months against traitors, two thirds less in numbers and inferior in resources for war of every description—and the traitors still not only unsubdued, but apparently vigorous and threatening as at the beginning—call loudly upon the people, without distinction of party or opinion, to make inquiry as to the cause of disaster, and to unite with all their heart, mind, and might in urging on and sustaining the Executive in a more vigorous and successful prosecution of the war, that it may be a short war, and that its end may be a speedy and honorable peace, with every State restored to the Union and the Constitution.

*Resolved*, That we recognize in Abraham Lincoln, the chief executive magistrate of the nation, commander-in-chief of the army and navy of the United States, a responsible and constitutional head, whose rightful authority and power ought always to be vigorously and religiously guarded and preserved as the condition on which our form of government and the constitutional rights and liberties of the people can be saved from the wreck of anarchy or the gulf of despotism. Now, more than any other time in the history of the republic, the President ought zealously to guard himself, lest in the assumption of war powers, as the commander-in-chief of vast armies, he transcend the limits and bounds set by the fathers to guard the liberties of the people.

*Resolved*, That we have read with pleasure the declaration of the President, as commander-in-chief, in his proclamation of Sept. 22, 1862, that the war hereafter, as heretofore, "will be prosecuted for the object of practically restoring the constitutional relations between the United States and the people thereof, in which States that relation is or may be suspended or disturbed." We know that in the mode and manner of conducting this war to that issue, in the means and policy to be adopted in its prosecution, a solemn and fearful responsibility rests upon him.

*Resolved*, That freedom exists only under the Constitution; it confines and limits authority; it defines executive, legislative, and judicial power. Without a strict and guarded observance of and adherence to it, military power, which in time of war, within rebellious districts, occupied by armed forces, arrests its citizen, condemns and executes him by decree of court martial, might become supreme and perpetual over the whole land, and the Government be made a despotism. In this time of war we want men in our Congress who shall be vigilant, sleepless, and far-seeing watchmen upon the towers of freedom—shall guard against the slightest encroachments upon the legislative and judicial powers, and shall see to it that those great safeguards to liberty, exemption from arrest without legal warrant, trial by jury, and the writ of *habeas corpus*, are preserved in loyal and peaceful States. In times like the present, passion is apt to overwhelm reason and judgment. Now, and for years to come, during the war, at the end of the war, after the war questions are to be discussed and determined more tremendous in their consequences than have been presented to the nation since the founding of the government. We need legislators who are patriots and statesmen. Massachusetts no longer wants men to represent her who see one thing so clearly that they can see nothing else.

*Resolved*, That we offer the thanks of this convention

to the loyal States of the border, for their devotion to the Union, the Constitution, and the flag. We know what they have suffered. We know against what they contended. We know the strength of their patriotism. It is firm and true when hostile armies encamp upon their soil and devastate their homes. And we brand as false and wicked the imputation of fanatics, and partisans that their loyalty is doubtful, and, therefore, their counsel should be spurned. God bless Maryland for the last proof of her fidelity. God help the brave State of Kentucky, cursed to-day by the tread of a rebel army. Her people are our people, her cause is our cause, and it is our proud confidence that she will pass through her present trial with her fair fame untarnished, and while she routes those who have invaded her, will confound those who have slandered her.

*Resolved*, That Massachusetts responds with full heart to the acclaim with which the army of Virginia greeted the appointment to its command of Maj.-Gen. George B. McClellan. We put trust in him whom brave men desire to do battle for our cause. Let all irregular and irresponsible intermeddling with his command of the army, whether in high places or low, by letter writers in camp or governors in convention, anywhere and everywhere, henceforth cease.

A complete party organization was also made by the convention.

On the next day, the 8th, a convention, representing the democratic party, assembled at Worcester, and declined to make any nominations for State officers, but adopted the following resolutions, as expressive of their views on national affairs:

*Resolved*, That the democracy of Massachusetts, waiving the expression of their views on questions not rendered imperative by the imperilled condition of our country, will continue to render the National Government their sincere and united support in the use of all legitimate means to suppress the rebellion, and maintain the Constitution and restore the Union.

*Resolved*, That we believe the Constitution of the United States, formed in wisdom by our fathers, gives to the constituted authorities ample power to suppress rebellion, and we earnestly invoke the President to stand by that sacred instrument, so that all loyal and law-abiding people may with earnest, confiding hearts stand by the President; and while we yield a ready and cheerful obedience to all the requirements of the Constitution, we demand of the Government and governed alike an unwavering fidelity to and enforcement of all its safeguards and provisions.

*Resolved*, That in common with and adopting the language of the President, our "paramount object in this struggle is to save the Union, and is not either to save or destroy slavery;"

That the policy announced by Congress in the resolution unanimously adopted in July, 1861, cannot be departed from without a violation of the public faith.

[See first resolution of people's convention.]

*Resolved*, That we are opposed to the doctrines of secession and abolition, both of which tend directly and surely to the destruction of the republic, and that there can be no permanent union or confederacy of independent States where the right of secession is admitted, or where any State, by a claim of "higher law," usurps the right to disregard the Constitution or bond of Union by which such States are united.

*Resolved*, That during this rebellion, which requires the whole strength of the people to subdue, the introduction and discussion of mere partisan questions or higher law theories, are calculated to weaken the hands and unnerve the heart of the soldier, to awaken distrust and jealousy among the people, to arouse the slumbering animosities of party; to beget strife and dissension among ourselves, and thus deprive our action of its great moral power and grandeur; therefore,

**Resolved,** That we deeply regret that the President of the United States, at this time forgetful of his obligations to the whole country, as the constitutional head of the Government, and yielding to unwise counsels, should have declared in proclamation of Sept. 22, 1862, his determination to adopt hereafter, in the prosecution of our deplorable civil war, the policy of a party which the House of Representatives, by the resolution of Feb. 11, 1861, unanimously declared to be too "insignificant in numbers and influence to excite the serious attention or alarm of any portion of the people of the republic."

**Resolved,** That in the name of civilized humanity, we respectfully but earnestly protest against the emancipation proclamation of the President of the United States, both on the ground of its unconstitutionality and inexpediency, and unjustifiable on the ground of military necessity, as it is prospective, not immediate, in its action, and we accept as conclusive reasons against it the unanswerable arguments of the President himself to the self-constituted Chicago delegation: that it deprives the noble Union men in the rebellious States, alike with the most guilty, of their property; that if inoperative it will bring down upon us the scorn of the world, and if capable of practical execution it must produce a war of races, in which all alike, the innocence of woman and the helplessness of childhood, must suffer with the guilty, and which must sooner or later end in the extinction of the negro race in the Southern States.

**Resolved,** That in order to prevent such deplorable results we feel it incumbent upon us to use all honorable efforts to surround the President with sound, safe, and wise counsellors, and send to Congress from this Commonwealth statesmen, whose standard of loyalty is neither above the Constitution, nor in conflict with it.

**Resolved,** That the right of trial by jury, and the ancient and constitutional right of this people to canvass public measures, should be at all times, and in all places, as well in time of war as in time of peace, jealously guarded;

That the right of the writ of *habeas corpus* is older than the Government itself; it is one of the main pillars of the common law, and the great bulwark of civil liberty, with the wisdom of centuries pleading for its sanctity, and under the Constitution there is no power that can suspend it except the Congress of the United States, and, as the people of the loyal States have voluntarily given millions of their treasure, and thousands of their sons to sustain the Government, no exigency requires its suspension, and we therefore call on the President to recognize the loyalty of the people, by restoring to them the right of trial by jury and freedom of speech, and of the press.

**Resolved,** That meetings of the governors of States, with the view to control or shape the policy of the General Government, or to dictate terms to the President, is not only not warranted by the Constitution, but is revolutionary in its tendency, and deserving severe reprobation.

**Resolved,** That the services of Maj.-Gen. George B. McClellan entitle him to the grateful acknowledgments of the people, and that any attempt to deprive him of the command he now holds, or to embarrass his plans or impair the confidence with which the soldiers and people regard him, whether made by conventions of Governors, by Senators, or Congressmen, or any other politicians, is fraught with great danger to our cause and deserves the severest censure.

The election took place on the first Tuesday of November, and the votes of the electors were given as follows:

	1862.	1861.
Republican.....	80,835	65,261
People.....	52,587	Democrat 31,266

The votes for members of Congress were given as follows:

	Republican.	Peopla.
1st District.....	8,899	2,762
2d ".....	9,271	5,884
3d ".....	5,044	5,020
4th ".....	5,828	5,851
5th ".....	8,505	5,898
6th ".....	8,124	6,152
7th ".....	7,994	6,496
8th ".....	10,128	5,178
9th ".....	14,811	No candidate.
10th ".....	7,449	5,785

The members of the Legislature were elected as follows:

	Senata.	House.
Republican.....	35	198
Democratic.....	5	41

A proposition was made to Gov. Andrew, on the 30th of September, from Gen. Dix, commander at Fortress Monroe, with the approbation of the War Department, to receive into Massachusetts a certain number of the slaves, or "loyal blacks," collected there, whose removal was desirable "for reasons both military and humane."

The correspondence was conducted through Major Bolles, of Gen. Dix's staff, and the governor. It was contemplated to relieve the Government, by the removal of a large number to Massachusetts and other Eastern States. The governor, although earnestly invoked on the subject in the name of humanity to the "loyal blacks," declined to receive them, on the ground that their stout arms could be of service in fighting for liberty. He further said:

Contemplating, however, the possibility of their removal, permit me to say that the Northern States are, of all places, the worst possible to select for an asylum. These poor people, afloat upon the world, are inhabitants of a southern climate, and have habits, and are subject to needs and to peculiarities of physical constitution accordingly. Where, then, is the prudence or the humanity of subjecting them at once to the rigors of our northern sky, in the winter season, with the moral certainty of inflicting extreme suffering, resulting probably in disease and death? If their removal is definitely determined upon, I would take the liberty of suggesting for the asylum some Union foothold in the South—as Hilton Head—where they could retain their health, be trained as soldiers, and their labor be rendered economically available. For them to come here for encampment or asylum would be to come as paupers and sufferers into a strange land and a climate trying even to its habitués, as a swarm of homeless wanderers, migrating without purpose, and not to the wilderness where the strong arm would suffice for maintenance, but to a busy community where they would be incapable of self-help—a course certain to demoralize themselves and endanger others. Such an event would be a handle to all traitors and to all persons evilly disposed. We should be told that the experiment had been tried and had failed; that the negroes were proved worthless and incapable of taking care of themselves, when the truth would be that we had pursued the plan most eminently calculated to disable and corrupt them. I meet with pleasure the motives of humanity which have dictated your proposed plan; but from the very same feelings I must consider the plan mistaken. It is precisely because I do not wish the negroes to suffer; precisely because I would save their wives and children from perishing; precisely because I do not wish their new freedom to become license, corruption, and infamy, that I respectfully decline to aid or countenance your plan for their transportation to the North.

MCCULLOCH, BEN, a general in the Confederate army, born in Rutherford co., Tenn., in 1814, killed in the battle of Pea Ridge, March 7, 1862. He was a son of Alexander McCulloch, who fought under Gen. Jackson at the battles of Talladega, Tallahassee, and Horseshoe, during the Creek war. He attended school in Tennessee until he was 14 years of age, and from that time until 21 was mostly engaged in hunting, in which occupation he became highly skilled. This life gave him a taste for adventure, and, upon learning of an expedition of trappers to the Rocky Mountains, he made arrangements to join them; failing in this, however, he engaged to join the expedition of David Crockett to Texas, to take part in the revolution; but, arriving at Nacogdoches, the place of rendezvous, too late, he proceeded alone to the river Brazos, where he was taken sick, and did not recover until after the fall of the Alamo. In 1836 he joined the Texan army under Gen. Sam Houston, and was assigned to the artillery. He served gallantly at the battle of San Jacinto, and afterward settled in Gonzales co., Texas, and was employed on the frontier, surveying and locating lands. Upon the breaking out of the Mexican war he raised a company of Texan rangers, and arrived at the seat of war four days after the battles of Palo Alto and the Resaca. His company were accepted by Gen. Taylor, and won great honor at the battles of Monterey and Buena Vista. He afterward joined Gen. Scott's army, and for his gallant services at the taking of the city of Mexico, was appointed United States Marshal of Texas by President Pierce. In 1857, he was appointed, in conjunction with ex-Governor Powell, commissioner to Utah. At the time of the inauguration of President Lincoln he was in Washington, it was believed, making arrangements, at the head of a body of secessionists, to take possession of the city; but, owing to the precautions of Gen. Scott, the idea was abandoned. He was subsequently made brigadier-general in the Confederate army, and assigned the command of the Arkansas forces. In June, 1861, he issued a proclamation to the people of Arkansas to assemble at Fayetteville to defend the State from invasion from Missouri. He commanded at the battle of Wilson's Creek, where Gen. Lyon was killed, and, it was said, having some misunderstanding with Gen. Price, surrendered the command to him. At the battle of Pea Ridge he led a corps of Arkansas, Louisiana, and Texas troops, and fell on the second day of the engagement.

McNAB, SIR ALLAN NAPIER, Bart., a Canadian statesman, born at Niagara, C. W., Feb. 19, 1798, died at Toronto, C. W., Aug. 8, 1862. He was of Scottish family, his father, lieutenant Allan McNab, having been appointed by Gen. Simcoe one of his aids when he came to explore Canada, and his grandfather having been a captain of the 42d Highlanders. At the age of 14 the subject of this notice joined the

grenadiers of the 8th regiment, who were stationed for the defence of Toronto, when attacked by the Americans in 1812, and was compelled to retreat with his regiment to Kingston. He was promoted to the rank of ensign during the war, but at its conclusion left the service and commenced the study of law at Toronto. In 1824 he was admitted to the bar and settled in his profession at Hamilton, C. W., where his public enterprise greatly contributed to the growth and improvement of the city. In 1829 he was elected a member of the Provincial Assembly from the county of Wentworth, and after serving three terms was returned by the electors of the city of Hamilton. In the ensuing session he was chosen Speaker in the House of Assembly, and was serving in this capacity, when the rebellion, headed by William Lyon Mackenzie, broke out. Sir F. B. Head wrote to him informing him of the peril in which the Government was placed, and he immediately marched from Toronto at the head of the militia, routed the insurgents on the 7th of Dec. 1837, and soon after seized the Caroline, a steamer used by the insurgents for communication with the American shore, set it on fire and sent it over Niagara Falls. This act occasioned much excitement in the United States, and led to some threats, but the English Government sustained Colonel McNab, and on the 14th of July, 1838, he was knighted by patent, and received the thanks of the governor-general of Canada, and the Provincial Legislatures. The Union of the Upper and Lower Provinces deprived him of his emoluments of office as speaker, and the governor-general asked the British Government for compensation for him, but was refused. He was subsequently a member of the provincial cabinet, under several administrations, and prime minister in 1854-6. In Feb. 1858 he was created a baronet of the United Kingdom. He subsequently spent three years in England, and in 1859 contested Brighton, Eng., for Parliament, in the conservative interest, but was defeated. His title became extinct with his death, as he left no male issue.

MEADE, Rt. REV. WILLIAM, D. D., a bishop of the Protestant Episcopal church, in the State of Virginia, born in Virginia, Nov. 11, 1789, died at his residence near Millwood, Clark co., Va., March 14, 1862. He was a son of Col. Meade, the confidential aid of Gen. Washington, graduated at Princeton College, N. J., in 1808, and, in 1811, was ordained to the ministry of the Protestant Episcopal church. He was a man of marked character and extensive influence. He took an active part in the establishment of a diocesan theological seminary, and various educational and missionary societies connected with his denomination in Virginia. In 1829 he was elected and consecrated assistant bishop of that State, and, upon the death of Bishop Moore, in 1841, took the sole charge of the diocese. In 1842, ill health obliged him to apply for an assistant, and Dr.

Johns, of Baltimore, became his associate. Bishop Meade was the author of several tracts and treatises on doctrinal questions, local church history, &c.. In 1834, he published "Family Prayer;" in 1849, "Lectures on the Pastoral Office," "Lectures to Students;" in 1856, "Old Churches, Ministers, and Families in Virginia."

**MEMPHIS.** Immediately after the naval engagement opposite Memphis, June 7, several prominent citizens of the place went on board the flag ship to inquire of Com. Davis his intentions with respect to the city, and a correspondence thereupon took place between the commodore and the mayor. (See *ARMY OPERATIONS.*)

A satisfactory arrangement was thus made with the civil authorities, all the more readily as the mayor and a great many of the citizens—according to some accounts the majority—were Union men. In the mean time Col. Ellet, commanding the ram fleet, had made an independent movement toward placing the city under the Federal authority, of which the following is his official report to the Secretary of War:

U. S. RAM SWITZERLAND,  
OPPOSITE MEMPHIS, June 7, P. M. }

Hon. E. M. Stanton, Secretary of War:

Sir: Yesterday, after the engagement with the rebel fleet had nearly terminated, and the gunboats and one of my rams had passed below, I was informed that a white flag had been raised in the city. I immediately sent my son, a medical cadet, Chas. R. Ellet, ashore with a flag of truce and the following note to the authorities:

"OPPOSITE MEMPHIS, June 6. I understand that the city of Memphis has surrendered. I therefore send my son, with two United States flags, with instructions to raise one upon the custom house and the other upon the court house, as evidence of the return of your city to the care and protection of the Constitution.

"CHAS. ELLET, Jr., Commanding."

The bearer of the flags and the above note was accompanied by Lieut. Col. Conkell, of the Fifty-ninth Illinois regiment, and sixty-two men of the boat guard.

The following is the reply of the mayor of the city:

"MEMPHIS, June 6.

"Col. Chas. Ellet, Jr., Commanding, &c.:

"Sir: Your note of this date is received and the contents noted. The civil authorities of this city are not advised of its surrender to the forces of the United States Government, and our reply to you is simply to state respectfully that we have no power to oppose the raising of the flags you have directed to be raised over the custom house and post office.

"JOHN PARK, Mayor."

On receiving this reply the small party proceeded to the post office to raise the national flag, and were there joined by the mayor. It is proper to say that the conduct of the mayor and some of the citizens was unexceptionable. The party was surrounded by an excited crowd, using angry and threatening language, but they ascended to the top of the post office and planted the flag, though fired upon several times and stoned by the mob below. Still I believe this conduct was reprobated by the people of standing in the place; indeed, many evidences of an extensive Union feeling there reach me.

Respectfully,

CHAS. ELLET, Jr.,  
Commanding Ram Fleet.

The same evening the citizens, to the number of some 2,000, reported themselves, armed and equipped, to the provost marshal to prevent the destruction of property by the mob,

who it was feared would fire the city, in fulfillment of a threat which had been made some time previously; but, beyond the breaking open of the Mississippi and Tennessee railroad depot, little or no disorder occurred. The same day Col. Fitch issued a proclamation to the citizens, announcing that he had taken military possession of the city. "Residents who may have fled from their homes," he continues, "are exhorted to return; merchants and others who have abandoned their business are requested to reopen their stores and shops, excepting those dealing in intoxicating liquors, who are forbidden to resume that traffic under penalty of having the stock immediately destroyed. The mayor and common council will continue in the exercise of their municipal functions, the military authorities simply cooperating with them in enforcing all proper ordinances, unless some exigency arises rendering it imperative to place the city under martial law. It is hoped and believed, however, nothing will occur to render this step necessary." In fact, the most perfect tranquillity continued to prevail; the municipal authorities cooperated cordially with the military in preserving order; and great numbers of citizens, who had fled on the destruction of the Confederate fleet, began to return to their homes. Before the surrender, 1,494 bales of cotton, and large quantities of sugar and molasses, had been destroyed by order of the Confederate Government, but the citizens had succeeded in concealing probably \$150,000 worth of these staples, which now began to find their way to the levees. Any person was allowed to go North, or ship goods thither, on taking the oath of allegiance. Trade was extremely dull for a week or two; many of the shops remained closed, and owing to the lack of every species of currency except Confederate scrip, Northern merchants, who had sent goods to Memphis, were in several instances compelled to reship them.

The Memphis post office was reopened on June 18.

On the same day Col. James R. Slack, of the 47th Indiana volunteers, assumed command of the city, and immediately issued the following order:

General Orders No. 8.

HEADQUARTERS UNITED STATES FORCES, }  
MEMPHIS, TENN., June 18, 1862.

Hereafter the dealing in and passage of currency known as "Confederate Scrip" or "Confederate Notes" is positively prohibited, and the use thereof as a circulating medium is regarded as an insult to the Government of the United States, and an imposition upon the ignorant and deluded.

All persons offending against the provisions of this order will be promptly arrested and severely punished by the military authorities.

By order of JAS. R. SLACK,  
Colonel Commanding Post.

The Mayor and Board of Aldermen addressed a letter to Col. Slack, representing that in the absence of almost all other money the order above cited was certain to cause great distress

and suffering among the laboring class, and requesting him to leave the matter for sixty days "to the judgment and discretion of the people." Their request was not granted, Col. Slack reminding them in his answer "that the so-called Confederate States issued all their notes in bills of the denomination of \$50's and \$20's," and that consequently the laboring class probably had very few of them in their possession. "The ruinous effect to which you allude," he continued, "will strike a different class altogether. The calamity of having to contend with a depreciated currency, and to which you refer, will come upon the people sooner or later, and I see no reason why it may not as well come now as sixty days hence.

"Those who have been the most active in getting up this wicked rebellion, are the individuals whose pockets are lined with Confederate notes, and if sixty days' time should be given them, it is only giving that much time for those who are responsible for its issue to get rid of it without loss, and the worthless trash will be found in the hands of the unsuspecting and credulous, who have always been the dupes of designing Shylocks, by inducing them to accept of a circulating medium which was issued to aid in the destruction of the first and best Government ever known to civilization."

On the 17th Gen. Lewis Wallace arrived at Memphis, and assumed the chief command by virtue of his rank. His principal official act, during the few days that he remained in Memphis, was to take possession of the "Argus" newspaper office, where he installed the correspondents of the "New York Herald" and "New York Tribune" as editors. The provost marshal also issued orders to the guard to shoot any one tearing down United States flags, and imprison citizens carrying concealed weapons.

On the 20th Col. Slack issued the following "General Orders No. 8:"

"Members of the Board of Aldermen, the Mayor, City Recorder, and all other persons discharging any official duty within the city of Memphis, and under the charter thereof, are required to come before the Provost Marshal and take the oath of allegiance to the Government of the United States within three days, or, in default thereof, will be regarded as sympathizing, aiding, and abetting rebellion, and will be arrested and treated as only traitors deserve."

On the 25th a Union meeting was held in Court House square, at which some 850 or 400 persons were present, about 200 of them being citizens. After several speeches had been made, a series of resolutions were passed pledging the support of the meeting to the Union ticket at the municipal election to be held the next day; and the meeting then adjourned, to reassemble in the evening for the purpose of nominating candidates. The election on the 26th passed off quietly, not more than 700 votes being cast. John Park, the Union candidate, was reelected mayor without opposition. All persons offering to vote were required to take the oath of allegiance.

The city was now for some weeks the headquarters of Gen. Grant, and Col. J. D. Webster was appointed commandant of the post. The editors of "the Argus" were permitted to resume the direction of their paper, with the understanding that their immediate arrest and the suppression of the paper would follow the appearance of any disunion article in it.

The Northern shipments from Memphis up to the 27th of June were, according to the report of the Trade Committee, 9,206 hhds. of sugar, 8,117 hhds. of molasses, and 7,061 bales of cotton. The number of persons who had taken the oath of allegiance in the city at the same date was estimated at 3,000.

On the 1st of July the "Memphis Avalanche" was suppressed, but its reissue being allowed on condition of the retirement of the chief editor, it appeared the next day as a "Bulletin."

On the 10th of July Gen. Grant published the following order:

"The families, now residing in the city of Memphis, of the following persons, are required to move South beyond our lines within five days from the date hereof:

I. All persons holding commissions in the so-called Confederate army, or who are voluntarily enlisted in said army, or who accompany and are connected with the same.

II. All persons holding office under or in the employ of the so-called Confederate Government.

III. All persons holding State, county, or municipal offices, who claim allegiance to the said so-called Confederate Government, and who have abandoned their families and gone South."

Gen. Grant went to Corinth on the 11th, and was succeeded at Memphis by Gen. A. P. Hovey, who published an order on the 16th requiring all male residents of the city, between 18 and 45 years of age, to take the oath of allegiance within six days or go South. About 1,300 took the oath and 500 were sent South. On the 17th it was discovered that a Confederate telegraph operator had interrupted the line between Memphis and Corinth, over which passed Gen. Halleck's messages to Flag Officer Davis, Gen. Curtis, and the Commandant at Memphis, and with the aid of a pocket instrument had read all the official despatches sent over the wire for four days.

Maj.-Gen. W. T. Sherman reached Memphis with reinforcements on the 20th, and took command of the post. On the 24th he published an order reopening trade and communication with the surrounding country under certain restrictions. Travel into and out of the city, over five specified roads, without passes or any hindrance except the right of search by the guard at the discretion of the officer in command, was freely permitted to farmers, planters, and business men with their families and servants. This travel must in all cases be by daylight, except in the case of market and supply carts. Another order prohibited the payment of gold, silver, or treasury notes for cotton, and ordered quartermasters to seize all cotton purchased after that date and send it North to be sold, the proceeds to be

held subject to the claim of the owners. Tennessee or Southern paper might be used for the purchase of cotton, or buyers might give obligations to pay at the end of the war, or at the pleasure of the Government, or might deposit the value of it with the quartermaster, to be held in trust for the planters. This order was soon afterward modified by direction of the Government at Washington.

A few days later Gen. Grant directed Gen. Sherman to "take possession of all vacant stores and houses in the city, and have them rented at reasonable rates, and to be paid monthly in advance." These buildings, with their tenants, were to be turned over to the proprietors on proof of loyalty. Houses, which had been leased by disloyal owners, were also to be seized, and the rents appropriated by the United States.

Early in August Gen. Grant ordered the families of all persons absent in the Confederate States to be sent out of Memphis.

On the 9th of the same month it was announced that one artillery and three infantry companies, comprising in the aggregate 400 men, had been enlisted in Memphis for the Federal army and had taken the field, and two others were recruiting.

Toward the close of the month Gen. Sherman issued an order prohibiting the importation and sale, except by permit, of arms, ammunition, salt, and salt meat; and commanding dealers to keep an account of goods received and the disposition made of them, said account to be subject to inspection at all times by the provost marshal. Dealers in arms and medicines, detected in endeavoring to get the same outside the Union lines, were to suffer the extreme penalty of military law.

A meeting of citizens was called by the General on the 7th of September, at which he made an address in answer to various complaints which had been made of his administration. The attendance was very large, and an unmistakable feeling of loyalty was indicated by the assembly.

About the 10th a joint order was issued by Gen. Sherman and W. D. Gallagher, agent of the Treasury Department, for the regulation of commercial intercourse between Memphis, Helena, and other points. No boats were to receive goods without permits, and persons who had never encouraged secession were to receive facilities for shipping supplies on their taking oath that no part of the same were to be sold to disloyal parties.

Up to this time, with the exception of guerilla raids in the neighborhood of the city, no hostile operations had taken place near Memphis since its surrender, and the military government, as a general thing, had been lenient. The operations of the partisan corps, however, became more serious; transports plying between Cairo and Memphis were fired upon from the shores, and about the end of September Gen. Sherman ordered that for every boat

fired upon thereafter, ten disloyal families should be expelled from the city. In accordance with this threat thirty families soon afterward received notice to quit the place, but the provost marshal was subsequently directed to grant fifteen days' grace to afford the Confederate Government an opportunity to disavow the actions of the guerillas.

On the 25th of October Gen. Sherman published stringent regulations for the government of the city. A military commission of three army officers was to sit daily to try offenders under the laws of war. Vagrants, thieves, and other disreputable characters, were to be organized into gangs and set to work in the trenches or on the streets. Citizens lurking about the camps were to be treated as spies. The inhabitants were to keep within doors between tattoo and reveille, unless attending church, places of amusement, a party of friends, or necessary business. After midnight, all persons must be in their houses, except the guard. Assemblages of negroes were forbidden, except by permission previously obtained from the provost marshal.

On the 7th of November another Union meeting was held at Memphis.

About the same time the General commanding prohibited the importation of liquors, except by gentlemen-citizens and officers, for the exclusive use of themselves and their families; by regular apothecaries for medicinal purposes, to be retailed on a physician's prescription; or by keepers of hotels and licensed saloons, in limited quantities, not exceeding one month's supply at a time.

Gen. Sherman took the field about the middle of December, and the command of Memphis devolved upon Gen. Hurlbut, who immediately caused all drinking saloons to be closed.

On the 21st of December the guerillas, who had been for some time growing daily bolder in their operations about Memphis, burning cotton, intercepting supplies, and forcing conscripts into the Confederate army, attacked the suburbs of the city, committed great depredations, and carried off 100 head of cattle and 180 mules. The next day a meeting of the citizens was held to provide means of defence. On the 24th the guerillas appeared again, drove the Federal pickets within the fortifications, and plundered the neighboring shops and houses. Two companies of citizens were immediately enrolled for home defence, and the provost marshal interdicted for the time all trade with the surrounding country. The arrival of two regiments of Federal troops, however, soon quieted the public alarm. In consequence of these occurrences, the election for member of Congress in the district of which Memphis forms a part, which was to have been held, under Governor Johnson's proclamation, on the 29th of December, was postponed twenty days. A quiet state of affairs ensued. The population of Memphis in 1860 was 22,623.



**METEOROLOGY.** In this department of science, the questions that have most engaged the attention of explorers during the year past, are those connected with the distribution of vapor in the atmosphere, and its relation to the air proper and to the barometer, as well as also certain points relative to the production and fall of rain. Some of the new views advanced appear likely to bring about important changes in meteorological theories, as well as in their practical applications. An abstract of these views, and of some other papers presenting features of special interest, will be given.

*Comparative Temperatures of the Air and Soil.*—M. Pouriau has during 5 consecutive years made observations of the temperature of the air at a few feet above the surface of the ground, and that of the soil at a depth of 2 mètres (about 6 ft. 6 in.). His results will, of course, hold very nearly true for all countries or sections having a like mean temperature and climate with France, or that, in other words, lie between the same isothermal lines, while with some modifications, they may be applied also to regions lying within the near isothermal belts on either side. Of those results, the following is a summary:

1. The mean temperature in the air for the year was  $50^{\circ}.37$  F.; in the soil,  $55^{\circ}.02$ : difference in favor of the soil,  $4^{\circ}.65$ .

2. The mean temperature of the soil in winter and autumn is higher than that of the air; in summer the former is about  $8^{\circ}.6$  lower; while in spring the mean temperatures of the two are very nearly equal.

3. The mean of the extreme maximum temperatures in the air was  $94^{\circ}.1$ ; in the soil,  $67^{\circ}.55$ . On the other hand, the mean of the extreme minimum temperatures in the air was  $10^{\circ}.15$ ; while in the soil this minimum never sank below  $42^{\circ}.8$ .

4. While in the air the mean of the total differences between the extreme maxima and the extreme minima reached  $115^{\circ}.95$ : in the soil this mean was only  $56^{\circ}.73$ .

5. In 1860, the mean temperature of the air sank to  $4^{\circ}$ ; in the soil the mean was never less than  $41^{\circ}.84$ .

6. While in the air the maximum temperature usually occurred in July or August, and the minimum in December or January, the time of maximum temperature in the soil always corresponded to the end of August; the minimum always occurred at the end of February, or on the first days of March.

7. The changes taking place in the temperature of the soil at the depth given may be thus stated: While the mean temperature of the air usually began to sink toward the end of July, in the soil the heat continued to accumulate in the superior layers under the influence of the still intense solar radiation, and from these to extend to the lower layers, until the end of August. From this time, the upper layers begin to lose by radiation upward into the air more heat than they receive from the sun; the flow

of heat in the soil accordingly now changes its direction, passing from the lower to the upper layers and becoming lost in the air; and this ascending movement continues until February, being more rapid as the external temperature is lower, *i. e.*, as the winter is longer and more severe. Toward the middle of February or the beginning of March, the upper layers of the soil begin again to become heated under the influence of the solar rays, the direction of which has become less oblique; the inferior layers give less and less heat to the upper ones; they begin on the contrary to receive some, and to become re-heated—this process going on with accumulating effect until August.

*Experimental Researches on Evaporation and Absorption.*—Two papers by Mr. Thomas Tate detailing such researches, with an account and drawings of corresponding measuring instruments, these being termed respectively "evaporimeters" and "absorbometers," appear in the "Philos. Magazine," 4th series, vol. xxiii, 1862. The object of the evaporimeter is stated to be that of determining with considerable precision the amount of evaporation which takes place from a given surface of water in different states of the atmosphere. In one of its forms, a large open-mouthed vessel has extending from it, and in a line rising very slightly above the horizontal as it recedes, a small tube, the vessel being filled with water to a certain height, and the tube at the same time being filled through a part of its length: a slight evaporation of water from the vessel, occasions a very noticeable recession of the water in the tube, and after a proper lapse of time, a displacement-gauge, which also dips into the water, being depressed until the liquid is returned to its first position in the tube, this gauge shows directly, by the level at which it then stands, the number of cubic inches of water in the mean time evaporated.

Among the results holding generally true in reference to evaporation from a water surface, it was found that—other things being in each case the same—the rate of evaporation is nearly proportional to the difference of the temperatures indicated by the wet and dry-bulb thermometers; 2, the augmentation of evaporation due to air in motion, is nearly proportional to the velocity of the wind; 3, the evaporation is nearly inversely proportional to the pressure of the atmosphere. In respect to spontaneous evaporation from surfaces of wet fabrics, &c., exposed to the atmosphere, this being nearly uniform so long as the temperature and hygrometric state of the air are constant, the following results were determined:—1. The rate of evaporation from damp porous substances of like material, is proportional to the extent of the surface presented to the air, without regard to the thickness of the substances. 2. The rate of evaporation from different substances mainly depends upon the roughness or inequalities of their surfaces, being most rapid in case of those most uneven; in fact, in this respect, the best

radiators of heat are the best vaporizers of moisture. The evaporation from a given surface of still water appeared to be  $\frac{1}{3}$  that of an equal surface of "calico" (*i. e.*, cotton cloth); while the latter, which vaporizes better than flannel, has very nearly the same power with woollen cloth, unsized paper, bran, or fine sand. 8. The evaporation from equal surfaces, of the same or nearly the same material, in a quiescent atmosphere, is very nearly the same in amount, whatever inclination the surfaces may have; as, whether upward, or downward, &c. This fact would appear to show that vapor does not, as has been supposed, pass from the evaporating surface by force of an ascensional current, except so far as it may at the same time be aided by a greater heat in the source, but that it is in reality carried into the air in the way of diffusion. 4. The rate of evaporation is greatly affected by the elevation at which the damp surface is placed above the level of the ground; and damp fabrics close to the earth may, when the sun's rays are feeble or wanting, even gain moisture by absorption, while similar ones a few feet above them are losing moisture in vapor. 5. The rate of evaporation is affected by the radiation of surrounding bodies; so that even a screen at a little distance above a damp surface caused the evaporation to go on from it more rapidly than from similar surfaces at the same time not exposed to such source of radiation.

*Dalton's Theory of an Independent Vapor Atmosphere questioned.*—Prof. Lamont, of Munich, in a recent letter to the distinguished meteorologist, Prof. Kämtz, calls in question the long-received theory of Dr. Dalton respecting the relations of the watery vapor of the atmosphere to the air proper, or dry air. Any dry gas flows into and diffuses through a space occupied by another gas, in the same manner as if such space were a vacuum. In accordance with this fact, Dr. Dalton was led to consider the actual atmosphere of the earth as a combination of as many distinct atmospheres as it has gaseous and vaporous constituents, each of these pressing only on itself, so that the actions of each might be treated irrespectively of the others. Meteorologists have since generally adopted this view; and in practice they have endeavored to separate the pressure of the aqueous vapor from the whole barometric pressure of the atmosphere, and thence to infer the separate "pressure of the dry air."

To this question, so important not only to a right investigation of the barometer, but also in connection with general physics, as to whether the aqueous vapor does, or does not, form an atmosphere independent of the air, Prof. Lamont addresses himself. Dalton's experiments showed that the same amount of water evaporates into a space filled with air as into an equal one destitute of air; and that, while evaporation takes place rapidly into a space void of air, it goes on very slowly in a space filled with air not in motion. Those ex-

periments in reality afford no information as to the mutual relations subsisting between the vapor and air: this deficiency Dalton supplied by interposing the hypothesis already stated. It has since been too much overlooked that the idea of an independent vapor atmosphere stands only as a possible, not as a necessary result of the experiments on which it was based. Objections to the theory were, however, from time to time presented, and especially by Bessel, Brown, Jelinek, and Espy.

Prof. Lamont believes that he himself first brought forward a decisive proof of the incorrectness of Dalton's theory (*Denkschriften der Münchner Akad.*, &c., 1857). He showed by observations extending over many years that the mean reading of the barometer stands quite as high in cases of a small, as in those of a great, vapor pressure. In the same place, he described an experiment in which a mass of vapor and a mass of air, placed in communication with each other, mutually preserve a state of equilibrium, without the vapor penetrating the air, or the reverse; and he laid down the proposition that the vapor of the atmosphere exerts a pressure on the air proper, and the air on the vapor. He has more recently endeavored to furnish the experimental proof that Dalton's laws themselves contain an essential error. The reasoning which led to the new experiments may be briefly stated as follows: If a little water be introduced into the bottom of an upright closed tube, and there gradually evaporated into the air above it, then, on Lamont's theory, that the vapor and air exert a mutual pressure, the expansive force of the vapor and air at any moment will act on any part of the interior of the tube by an amount equal to the sum of the expansive forces of the two; and while the vapor is yet undiffused through the air, its pressure, say upward against the top of the tube, will be just as great as after it has reached that surface. On the contrary, if Dalton's theory be true, the vapor must diffuse itself in the interstices of the air, and with no mechanical effect, until it becomes a confined body, that is, until it has reached the top of the tube. The conditions here supposed can be rendered sufficiently permanent to admit of testing the principle, by an arrangement in which the space furnishing the vapor is kept at a higher, and that representing the top of the tube at a lower temperature. To effect this, a glass tube having at one end a bulb, and a little above this bent at right angles, is so placed as to extend horizontally, and being farther on bent into a depending U shape, it runs horizontally again from this, terminating in an open end: into this last horizontal part a globule of mercury is introduced, to show, by the extent to which it is pushed along the tube, the pressures at different times exerted upon it by the confined atmosphere within the bulb, and included portion of the tube. The diameter of the tube used, was 1.1 Paris lines; and a point extending from

the bottom of the bulb being broken off to allow of introducing water into it, when desired, could then be replaced so as to close the bulb again.

The experiments were duplicate—first, with air only in the bulb, then with a little water added. In either case, the bulb was made to dip into a vessel of warm, and the U into another of cold water; the temperatures of both these were noted, and also the distances to which the mercury was moved along the tube. As an example of the experiments: the cold water in the second vessel being at  $12^{\circ}$  C., and the warmer water in the first being from  $15^{\circ}.7$  raised to  $41^{\circ}.8$ , the bulb containing air only, the mercury globule advanced along the tube 11.47 Paris inches. Water being afterward introduced, and when, by Dalton's theory, even if the vapor resulting had penetrated quite to the mercury, the latter should by the same temperatures have been moved, at most, but  $\frac{1}{8}$ th farther, it was found on trial that the actual motion produced was nearly doubled; and now, to secure movement of the mercury over 11.47 Paris inches, it was only requisite to raise the temperature of the bulb from  $15^{\circ}.7$ , to  $80^{\circ}.9$  C. Now, the calculated increase of the expansive force of the dry air, in the first case, equals .119 of its pressure at the outset; and the calculated increase of expansive force in the second case is for the dry air .070, and for the vapor .048, together making .118 of the pressure at the outset. An identity very nearly as close as this runs between the two classes of results in all the experiments; and in view of the fact (established by other means) that, in the cases of added vapor pressure, the vapor had not advanced even to the U bend of the tube, it follows accordingly that the vapor of the water, while yet but partially distributed through the enclosed space, is already exerting the full pressure due to its density and temperature. To determine whether the penetration of the vapor to the mercury would produce a difference in the result, the warmth of the water about the bulb was in one instance maintained for a full hour; but the mercury was not in consequence moved farther.

Professor Lamont concludes from these experiments and other data that Dalton's theory *must* be erroneous; that in the atmosphere, the air proper presses on the vapor, and the vapor on the air. This, however, expresses only the effect; and he anticipates being able to show, at some future time, that the humidity in the atmosphere must be regarded as actually adhering to the molecules of air; and that the phenomena admit of a simple explanation by means of a natural hypothesis concerning the expansion of dry and of wet molecules of air. Applying the new theory to the case of the atmosphere, it must be inferred, since the diffusion of vapor in air takes place very slowly, and since, from natural causes, very different quantities of vapor pass into the air at different places, that in regard to the humidity of the air no relations exist that can be, strictly speak-

ing, conformable to any law. Of course, the currents of air continually occurring will as constantly intermingle masses of air more or less humid; but this action takes place in no uniform manner. There can thus be no exact relation of dependence between the degrees of humidity of different points in space. But particularly, the idea of an atmosphere of vapor subsisting independently within the general atmosphere, appears wholly inadmissible; and the data furnished by the psychrometer can no longer be regarded in any other light than as expressions of local humidity of the places at which they are obtained.—"Philos. Mag.," Nov., 1862.

*Vapor of the Upper Atmosphere.*—Lieut.-Col. R. Strachey, in a long communication before the Royal Society, and which appears in the journal just quoted (April, 1862), furnishes a second proof of the inadmissibility of Dalton's theory. His position is that previously taken by Bessel, but supported by a wider and more exact survey of facts. An independent vapor atmosphere, if such exist, must within itself conform to the general laws of pressure of elastic fluids. But the specific gravity of the vapor is less than that of the dry air in the ratio of about .625 to 1, or 5 to 8. Consequently, the rate of diminution of pressure on the upper strata of the vapor atmosphere would be much slower than that holding true in respect to the air or general atmosphere; and, leaving aside any effect of temperature, the height required in the vapor atmosphere to produce a given diminution in density, must be to the corresponding height in the general atmosphere, inversely as the specific gravities of the two, or about as 8 to 5. Thus, the barometric pressure being by an ascent of about 19,000 ft. reduced one half, to reduce the pressure of the vapor atmosphere in like ratio a height of  $19,000 \times \frac{8}{5}$  = more than 30,000 ft. must be reached. Mr. Strachey then gives tables showing in parallel columns the tensions (and hence, the proportionate quantities) of vapor, at different elevations; first, as calculated from Dalton's theory, and secondly, as actually observed by Dr. Jos. Hooker, in ascending the Himalayas to upward of 18,000 ft., and by Mr. Welsh in balloon ascents to a height of 23,000 ft.

The vapor tension at the earth's surface, as observed, being called 1, and this being necessarily the unit or value for the same level by Dalton's theory, then the calculated tensions according to this theory, at heights respectively of 4,000, 8,000, 12,000, 16,000, and 20,000 ft., should be expressed by the fractions .92, .84, .77, .70, and .64 of the vapor at the surface; while the actual tensions found by Dr. Hooker at the heights severally named (the last only being determined by calculation), were as low as .68, .52, .35, .25, and .16 of the vapor at the surface; and those of Mr. Welsh for like elevations .77, .45, .30, .18, and .12 of the vapor at the surface. Observations for certain heights made at other points correspond nearly with those here given. (See, also, Mr. Glaisher's

conclusion on this subject, in the next section.) All the observations thus coincide in finding in the upper atmosphere much less vapor than Dalton's hypothesis requires—the tension and quantity of vapor being reduced at a rate much more rapid than can be supposed to occur in an independently subsisting vapor atmosphere. In reality, the tension diminished to  $\frac{1}{4}$  by an ascent of only about 8,000 ft., instead of 30,000. The practice of subtracting the vapor tension from the total barometric pressure, to find the simple gaseous pressure, is hence absurd; and the indications of the barometer thus "corrected" (as it is expressed) have no true meaning whatever.

The quantities of vapor disseminated in the upper parts of the atmosphere being very small, it follows that inequalities of level on the earth's surface, insignificant in respect to the dimensions of the globe, become of great importance in connection with the atmosphere and atmospheric phenomena. Three fourths of the whole mass of air is within range of the influence of the highest mountains; one half the air, and nearly nine tenths of the vapor, are concentrated within about 19,000 ft. of the sea level, a height hardly exceeding that of the mean level of the crest of the Himalayas; while one fourth of the air and one half of the vapor are within a height of 8,000 ft. Mountains, even of moderate magnitude, may thus produce important changes in respect of movements, temperature, and hygrometric state, in considerable masses of atmosphere, and this especially in those strata that contain the great bulk of the watery vapor, and that have the greatest effect, therefore, in determining the character of the climate.

*Meteorological Observations in Balloon Ascensions.*—An account of the balloon ascensions of Mr. Glaisher for scientific purposes will be found under the title "Ballooning." As might be anticipated in first attempts, the scientific observations made appear not to have been of very great extent; but some of them are, nevertheless, valuable. From the observations on temperature, which were among the most complete, the following table, including four of the ascents, was constructed. In it are shown the actual temperatures at the earth and for every 5,000 ft. of elevation, and also the corresponding decrease of temperature between any two consecutive elevations:—

Height above the level of the sea.	Temperature of the air.					Decrease of temperature for each 5,000 feet.
	July 17.	Aug. 18.	Aug. 21.	Sept. 5.	Mean.	
— feet ...	61.2°	69.6°	62.0°	62.9°	63.8°	....
5,000 " ...	39.7°	48.0°	48.8°	41.4°	48.1°	20.7°
10,000 " ...	28.0°	40.7°	32.0°	31.0°	32.9°	10.2°
15,000 " ...	31.0°	31.1°	19.0°	31.0°	25.7°	7.2°
19,500 " ...	42.2°	..	..	..	..	....
20,000 " ...	38.0°	25.9°	..	10.6°	28.2°	2.5°
25,000 " ...	16.0°	23.9°	..	0.0°	18.3°	9.9°
30,000 " ...	..	..	..	-5.8°	..	....
Decrease of temperature in 25,000 feet...	44.9°	45.7°	..	62.9°	50.5°	....

The results of July 17 are highly anomalous. Up to 10,000 ft. the decrease accords with that of the other experiments; from 10,000 to 20,000 ft. a remarkable deviation occurs; while above 25,000 ft. the results again accord. Proceeding upon the data obtained up to 10,000 ft., and again at 25,000 ft., it results that at 15,000 ft. there was an excess of 8°.3 of temperature; at 19,500 ft., 22°.2 excess; at 20,000 ft. 5 excess. The average decrease of temperature is seen to be over 20° for the first 5,000 ft., and over 10° for the next; while for 25,000 ft. it is nearly 51°. In another table, including the eight ascents, and giving the temperature for each 1,000 ft., from the earth up to 5,000 ft., the mean decrease of temperature is found to be more than 21° for the first 5,000 ft., so that full  $\frac{1}{3}$  of the whole decrease of temperature within 5 miles of the earth takes place in the first mile. The decrement of temperature in the several series of observations is not uniform, either for the whole height reached or for the first mile. Further elucidation on this point is desirable, particularly in reference to the influence of the irregularly decreasing temperatures of the strata of air on atmospheric refraction.

The observations made in respect to the humidity of the atmosphere show that the proportion of vapor decreases continually with increase of elevation; and in a rapidly augmenting ratio, until, at heights of 5 miles and upward, the quantity of aqueous vapor present in the air is extremely small. The electricity of the air was found to be positive, and decreasing in intensity with increase of elevation. A better test paper being in the latter ascents employed, the presence of considerable quantities of ozone in the air was indicated. Mr. Glaisher concludes, from his use of the aneroid barometer, that such an instrument can be constructed, which shall read correctly to the first, and probably to the second, place of decimals, and that also down to a pressure as low as 5 inches of mercury.

*Dew Bow on the surface of Mud.*—The small rainbows, or parts of such, seen upon spray formed in various ways, are familiarly known, as also the somewhat similar bows which may be seen upon grass heavily laden with dew, and which are known as dew bows. Professor Rankine, along with other persons, witnessed, on the 18th of February, 1862, a prismatically colored bow, exactly resembling the dew bow, but in this case displayed on the muddy surface of a by road near Glasgow, and also for more than a mile along the less trodden parts of an adjoining turnpike road. The morning had been hazy, but the mist had cleared away, and the sun was shining brightly: time (Greenwich) of the observation of the bows, between 12 30 and 1 P. M. The angular dimensions of this iris were obviously the same with those of a rainbow of the first order; its colors were complete, from red to violet, and very bright and distinct, especially where the mud was

most soft and moist. Where the road had been much disturbed, and over any pool of water, the iris disappeared, and no trace of a bow could be seen elsewhere, on the grass or in the sky. The conclusion drawn was that the surface of the mud was thickly covered with globules of pure water, perfectly spherical, and, although resting on the mud, not in absolute contact with it; but from their invisibility to the eye, these globules must also have been exceedingly minute.

*Soap Bubbles, and the Nature of Cloud.*—M. Felix Plateau, son of Professor Plateau, being about to throw out from a capsule, or broad, shallow vessel, a slightly viscid liquid, endeavored, by throwing it obliquely, to spread it out in a sheet; the unexpected result was that the film of liquid thus formed instantly drew together at the edges into a hollow bubble of 3 to 3½ inches diameter, which slowly fell. He then repeated the experiment many times with soap suds, and always successfully, while now there were usually several bubbles formed at each trial, sometimes as many as fifteen at once, their diameter less as the number increased. He succeeded best with a vessel of basin shape, about 6 inches in diameter, and containing a considerable quantity of liquid—1 part of Marseilles soap to 40 parts of water—the liquid being thrown out at an angle of about 45° with the horizon, the person turning rapidly round meanwhile, so as to produce as extensive a sheet as possible. Observing from an upper window, while another below performed the experiment, he discovered that the liquid sheet of very irregular form, and indented on the edges, was resolved along the edge into numerous full drops, while the remainder of it was generally torn into several parts, each one of which closed up rapidly, so as to form a complete bubble.

It has long been a disputed point among meteorologists whether clouds are composed of minute solid drops or of almost equally minute hollow spheres or vesicles. Saussure declares that he caught and measured, on the Alps, particles of cloud, the vesicular character of which was unquestionable. The actual lightness of the particles which form even very dense and opaque clouds, and the fact that clouds do not, as do collections of solid drops, show rainbows, have long been instanced in confirmation of the theory of vesicles; while among the chief objections to it has been the difficulty of conceiving how the vapor, in passing to the liquid state, could aggregate in the form of envelopes enclosing air. Professor Plateau considers that the experiments above alluded to help to solve this difficulty, since they show that the molecules of water need not directly aggregate in the form of vesicles. It is sufficient that the molecules at first unite in open sheets of any figures or curvatures; each of these will then immediately close, so as to give rise to a vesicle. And the formation of the films, however difficult in itself, is more easily conceived than

the formation at once and entire of the vesicular bodies.

*Question of Formation of Rain near the Earth: Rain Gauges.*—Since the year 1767, many meteorologists have come to adopt the opinion that the larger part of the rain which falls on the surface of the earth does not proceed from the clouds, but is derived from the lower strata of the atmosphere, within 200–300 feet of the surface. This paradox arose chiefly in consequence of experiments in which rain gauges placed at moderate elevations in the atmosphere were found to collect much less rain than those placed on the ground—a result which will commonly hold true in testing the rain fall with the usual forms of rain gauges and in the ordinary manner.

Now, it must be observed, that in these experiments the higher gauges are placed on the roofs of houses, the summits of church towers or other erections; and that not only are all these objects which present themselves as obstacles to the wind, but that the common form of gauge is itself, though of so much less size, such an obstacle. To determine the effect of such obstructions, Mr. W. S. Jevons, author of the paper from which this abstract is made, set up at a distance of ¼ of an inch apart, two oblong plates of glass, and causing a current of air continually charged with smoke to ascend between these, he introduced at one side, within, a small obstacle to represent a house or gauge: with such an arrangement, it could readily be observed that the moving current of air between the plates, obstructed at the place of the object, rose in a curve over it, and in this part of its course moved more rapidly; the curves traced by the smoky air in its movement being exactly observed, were represented in a drawing; and the relative velocities in the several parts of the current were also noted. In like manner, when a wind, the movement of which can be taken as in a general way uniform, meets an obstacle, some parts of it must move more rapidly in sweeping over the latter, just as, also, a river flows most rapidly in the narrowest part of its channel. As parallel facts, a wind is known to be in all cases most fierce at the corners of buildings, the ends of high walls, or on the summits of hills.

Mr. Jevons considers, that in the facts now given is to be found the whole explanation of the observed deficiency of rain in elevated rain gauges. A falling rain drop is influenced at once by gravity and the motion of the air; it moves through the diagonal of a rectangle, of which the perpendicular represents the velocity of fall, and the horizontal the force of the wind. If at some fixed point, as the summit of an obstacle to the wind, there occur continually an increase in this horizontal force, the rain drops will at such place be as constantly hurried along and spread apart in their course, so that fewer drops (less rain) can there fall on a given surface than will fall where no such interfering cause operates, and a surplus of rain

will be carried to and fall at the lee side of the obstacle. A first corollary from this reasoning is, that, did the instrument or its support cause no disturbance in the wind, no deficiency of rain would appear. But only a gauge with its mouth level with the ground can fulfil this requirement. And in the case of elevated gauges, it is probable that the house or tower causes the chief part of the deficiency in the rain caught. [Another consequence is, that in absolutely calm rains, if the view taken be correct, the deficiency in the elevated gauge should not appear.]

A number of facts confirmatory of the view given are then presented. Mr. H. Boase, of Penzance, July, 1822, having observed the quantity of rain caught in gauges on the ground and in an elevated position, concludes that "the difference of the quantity of rain caught in a gauge placed on the top of a building, and one at the level of ground, is, for some reason or other, proportional to the velocity of the wind." The measurements given by Luke Howard, when arranged in the order of difference of quantity of rain caught at the same times in higher and lower gauges, are also found to be arranged exactly in the order of the force of the accompanying wind, as given in notes annexed. Thus, in rains attended with a strong wind, the ratio of difference in the two sets of gauges is from 8 : 1 down to 1.75 : 1; in those with light and scarcely noticeable winds, it is from 1.6 : 1 down to an equality in the two. The continued meteorological observations at Greenwich Observatory and elsewhere, exhibit an extreme irregularity and discordance in the results of measures of fall at different heights, showing at least that in a case of this sort we cannot appeal to average results, but must have specific, careful observations. Yet many individual instances are found in the Greenwich records which corroborate the position taken. Prof. Phillips, for some time in charge of the observatory named, himself remarks that a great deficiency in the upper gauge was a phenomenon of wintry character; and as a rule the deficiency is more marked in March than in any other month. Dr. Trail and Mr. Meikle referred the difference in some way to action of the wind; and the latter nearly anticipated Jevons' views. Prof. A. D. Bache, in a paper before the British Association, 1838, on the effect of deflected currents of air, and the quantity of rain collected by rain gauges, showed by experiments the immense difference that may occur between gauges placed at the different angles of the same building; and he found also that the gauges to leeward received generally more rain than those to windward.

In another way, reasoning from the known conditions of the air in higher and lower strata, in reference to temperature and saturation, Herschel has shown that within the last 213 ft. of the ground not more than  $\frac{1}{4}$ th of the quantity of rain to be accounted for could possibly be added to the fall. Mr. Jevons proceeds to prove

that even Herschel's allowances on this score are too liberal, and that under no circumstances will the increase of falling rain within the last few hundred feet be more than almost infinitesimal. In fact, distant showers of rain are often observed which evaporate and vanish before reaching the ground; but no observations of the reverse character are known. A second argument in favor of increase of rain near the earth, drawn from the fact that the internal supernumerary fringes of rainbows are only seen in the upper parts of the bows, never near the earth, and as proved by Dr. Young, are only producible where the drops are of equal size, is readily disposed of by remarking that the requirement in respect to the drops is equality of size, not any given size; and the jostling of drops together by the wind, or either increase or decrease of some of the drops more than others, could alike give rise to the want of uniformity which seems to characterize the drops near the earth.

From the conclusions reached, it further follows that all observations by means of elevated or exposed rain gauges must be rejected as fallacious or useless. And the most unexceptionable rain gauge of the common kind, would be a sheet of metal, say 10 feet square, spread flat upon the ground in an open place, with a simple collecting vessel let down in its centre, and the edges of which should not rise more than an inch above the plate. In this there would be no appreciable loss by wind, nor irregularity from splashing. The water collected in such vessel should be conveyed by a pipe running from it below to a sunken reservoir or recording apparatus.—"Philos. Magaz.," Dec., 1861.—It may here be added that the new rain gauge, or pluviometer, of M. Hervé Mangon, of Paris, could doubtless be so arranged as not to present an obstacle by rising above the general level of the ground. This consists of a long strip of paper, prepared with solution of sulphate of iron, and after drying, rubbing with finely powdered galls, so that each drop of rain falling on its surface will produce an ink and so leave a black spot, this paper to be gradually unrolled by clockwork, so that in the course of 24 hours every part of it shall have been exposed to the open air. The sheet of paper is easily spaced for hours and minutes, and the relative frequency of the spots on its different parts shows the comparative, not the absolute, rainfall in different parts of the time occupied in unrolling it.

*Admiral Fitzroy's System of Weather Forecasts, Storm Signals, and Meteorological Telegraphy.*—President Fairbairn, in his opening address before the British Association, 1862, in course of allusions to the scientific and practical progress of the time, called attention to the labors of Admiral R. Fitzroy and his coadjutors in the collection of meteorological facts, and the application of the principles of the science to useful purposes. He stated that, in 1854, in consequence of representations originating with

the association, the Government created a special department in connection with the Board of Trade, under Admiral Fitzroy, its object being the obtaining of hydrographical and meteorological observations at sea, after the manner of those which had been for some years collected by the American Government, at the instance, and under the direction of Lieut. Maury. In the course of the system of observations, as now developed, especial attention has been given to the study of the winds, by means of the various self-registering anemometers of Whewell, Osler, Robinson, and Beckley.

Mr. Fitzroy read before the Royal Institution, March 28, 1862, a long and somewhat rambling paper upon the system of "forecasts" of the weather, with the plan of telegraphing the important results arrived at to various ports or other prominent points on the coasts of the British Islands, and the indicating of the information thus received to mariners on board ships within sight, by means of a prearranged system of weather or storm signals. The paper just referred to, however, deals more especially with the subjects of observations of the barometer and thermometer, and of winds, &c., and the connections supposed to be established between the characters of weather and winds and the indications of those instruments—in a word, with the basis of the supposed newly-developed system of weather forecasting and warnings. Although the meteorological department had been previously constituted, the first step toward the present system, embodying the employment of the telegraph for conveying forecasts of weather, was made at the Aberdeen meeting of the association already named, 1859. The department, advancing slowly at the first, transmitted to parts of the coast early in 1861 its first cautionary or storm-warning signals. These appear to have been in some parts disregarded; but on the following days a terrible storm ensued, with great loss of life, on the northeast coasts. Since that time the warnings have been continued, and the plan gradually perfected and extended. In August, 1861, the first published forecasts of weather were tried, and about six months later the system, as now in operation, became fully established. At the date of the paper above given, 20 reports of weather data were received each morning (Sundays excepted), and 10 each afternoon, besides 5 from the Continent; and double forecasts (*i. e.*, each day one, two days in advance) were published, with the full tables of observations on which they chiefly depend, in six daily papers, in one weekly when it appears, and also at Lloyd's, at the Admiralty, the Horse Guards, and the Board of Trade.

The foretellings of the weather in this system are not to be understood as prophecies or predictions: the term "forecast" was chosen as properly applicable to an opinion, the result of scientific observation and deduction, but which must still, occasionally, prove incorrect;

as, in case of the sudden "downrush" (Herschel) of southerly wind sometimes occurring, or of rapid electrical accumulation not yet sufficiently detectible by our senses or other existing methods. As must have been expected in the outset of an undertaking of such magnitude and novelty as this, whether in principle it be really sound or not, two opinions are held in England in reference to the correctness of the basis of these forecasts and the actual value of the warnings founded on them. By Mr. Fitzroy and his adherents, it is claimed that the system is well grounded upon the actual weather observations of its founder through a long course of years, together with an analysis of comprehensive and accurate weather tables (barometer and thermometer indications included) furnished for his use from the British shores and coast points, along with, of course, all the aid supplied by the general science of meteorology. By opponents, however, the sufficiency of the observations, and more especially the completeness of the analysis of these, and hence, the certainty of the general principles supposed to have been ascertained from them, are still decidedly questioned. Of these general principles, those which underlie the whole system, are: 1, that the condition of the air (as to heat, moisture, pressure, existing winds, &c.) foretells what the weather is soon to be, rather than indicates the weather that is present; 2, that the longer the time between the signs and the change foretold by them, the longer the altered weather (when occurring) will last; and conversely, 3, that the less the time between a warning and a change, the shorter the continuance of the predicted weather. As an example, now, of points at issue between the upholders and the critics of the practical system, Prof. Dove lays down that the advance current of an incoming north wind blows along the ground, and that the storm is upon us before the instruments afford due indication of it; while Fitzroy asserts that the north, like the south current, advances aloft at a considerable height; and that, therefore, the barometer will generally testify to the existence of the one as of the other, long before the actual change of wind. If the latter be in error in this particular, there necessarily follows a doubt in regard to a considerable portion of the forecasts.

Admiral Fitzroy has recently had published a volume entitled the "Weather Book" (London; Longman & Co.), in which he explains, for the benefit of those who may desire to apply it in any part of the world, the system of forecasts from present weather, and barometer and thermometer indications, along with the aid of such special weather "signs" as are considered trustworthy. His own forecasts are made from observations and reports daily received, as already mentioned, at the office of the department, in London. For convenience in making up, and telegraphing the forecasts, the British coasts are divided into 5 dis-

tricts, respectively known as—1, North Britain (including from the Moray Firth to the middle of Northumberland), along the coast; 2, Ireland, generally, around the coast; 3, Central (Wales to the Solway), coastwise; 4, East Coast (from Northumberland to the Thames); 5, South England (from the Thames round to Wales), by the coast. At the most suitable points along the coast in each of these divisions, main stations are established, at which a set of signals can be made to mariners within sight of those points, by means of hoisting upon separate poles or the same, a storm drum and cone; these at night are illuminated by lights placed within them. By an arbitrary and previously understood arrangement, the order or combination of these as hoisted is made to indicate a coming gale or tempest, its probable severity, and the quarter from which it will come. The warnings are telegraphed from the central office in London, as directly as possible to these stations, and to the principal ports; from these, as centres, the information is then conveyed to other points from which the signals cannot be seen. When practicable, the signals are displayed first at the point at which it is calculated the storm will first be felt, and from this progressively on to others, in accordance with its expected course. The warnings are thus quite generally conveyed to vessels in port and to craft near the shores; while from a large number of points visible to a distance at sea, they are also made known by the signals. It is still not expected that boats or ships shall delay sailing for a gale that, after all, may not happen: the real meaning of the signals is simply, "Be on your guard"—"A storm is probable"—"Consult your instruments and the signs of the weather;" or, in certain cases, "Make immediate preparation for a gale," &c. Persons contemplating brief voyages are also thus warned of occasions on which it is less safe to embark than at others. In very many instances, already, important testimony has been borne to the value of the weather forecasts and signals. The preparation of navigators within sight of the coasts for coming storms, not otherwise anticipated, is believed already to have resulted in the saving of many lives and large amounts of property. In the recent violent gale on the English coast, Jan. 17-19, 1863, it is believed that the fatality and marine losses would have been increased far beyond what they actually were, had not the classes concerned been warned beforehand by the Fitzroy signal drums and cones displayed along the coast.

When—admitting that the great system of the trade winds is equivalent to the maintaining of a certain general uniformity in the directions and character of the air currents for parts of the earth in which it prevails, including (though in less marked degree) even the temperate zones, the directions of the prevalent winds being generally the same for each region

or part in which the trades have an influence—it is nevertheless remembered that there are continual causes of disturbance or local variation in this regularity, as by changing temperatures of neighboring sections of the earth's surface or of strata of air at different heights, with changing amounts of evaporation, condensation, rain fall, &c., so that in fact at any given time, and particularly in temperate latitudes, air currents at the surface may be flowing side by side, but in opposite directions; or two, three, or more such currents may be superposed, the one flowing above the other, and in opposite directions or at any angle with each other: these movements being attended with collisions and intermixtures of bodies of air, and followed by the results naturally due to their unlike qualities, it will at once be seen that the interpretation of the continual variations of the barometer and thermometer along with present weather signs, so as (if it be really possible) to forecast with a good degree of certainty the coming weather, becomes in itself an extremely complex and difficult study. Of course, it is impracticable to present here even an outline, which should be of real value to the reader, of the principles by which the forecastings of the weather are attempted. Those principles necessarily include the rules for interpreting the indications of the barometer, but which Mr. Fitzroy has still further extended and particularized. Those who may be interested to prosecute the subject in its details, are referred to the "Weather Book," already named, to Mr. Fitzroy's paper in the "Philos. Magaz.," May, 1862; and to an abstract of his rules for "reading the barometer," in the "Journal of the Franklin Institute," May, 1862; and of course, to the standard works on Meteorology.

It may be here remarked, however, as a particular consequence of the general movement of the trade winds, that in the northern temperate regions a long-continued north wind tends to become easterly, and a continued south wind to become westerly. That is, the general tendency of the winds in shifting is to "veer"—turn to the right, or by a direct rotation; and it is much less common that they "back"—turn in the opposite course; the probability of the former change being to that of the latter at least as 2 to 1. Not unfrequently, within a lapse of time varying from 24 to 60 hours, the surface wind, starting it may be in the southwest or west, veers in this manner through the complete circuit of the points of compass (Dove's law of "rotation of the wind"). Great changes or storms are usually preceded by a fall of the barometer through an inch or more, and within a comparatively brief time. The tenth of an inch an hour may be taken as foretelling a tempest or very heavy rain. The more rapidly such changes occur, the more imminent and violent the approaching commotion. Mr. Fitzroy sums up as follows the influence of the three causes known (electrical



agency being yet uncertain) to affect the barometer:

1. The *direction of the wind*,—the N. E. wind tending to raise it most—the S. W. to lower it most; and wind from points of the compass between these, in proportion, as they are nearer one or the other extreme point. N. E. and S. W. may therefore be called the wind's extreme bearings (by some, its poles). Other things being the same, the entire range or difference of height of the barometer that can occur through change of the wind only, from one of these bearings to the other, amounts in these latitudes to about half an inch.

2. The *amount of vapor, moisture, rain, or snow* in the wind or current of air. Other things being the same, this appears capable of causing a change in an extreme case of about half an inch.

3. The *strength or force of a wind* (apart from other conditions), coming from any quarter. Other things being the same, the strength of the wind, according as less or greater, is preceded or foretold by a fall or rise ranging in an extreme case to more than two inches.

Hence, supposing the three causes to act together, in extreme cases, the height of the barometer would vary from near 81 inches to about 27 inches, before and during a given change of weather; and this, though rarely, has happened, and even in tropical latitudes. In general, however, the three causes act much less strongly and less in accord; just as ordinary varieties of weather occur much more frequently than extreme changes.

*Weather Signs.*—Mr. Fitzroy's summing up of the more marked "signs" of weather, useful alike to the seaman, the farmer, and the gardener, embraces the following indications:

Whether clear or cloudy, a rosy sky at sunset presages fine weather; a red sky in the morning, bad weather, or much wind (perhaps with rain); a gray sky in the morning, fine weather; a high dawn (the first daylight being seen above a bank of clouds), wind; a low dawn (the first light being low or in the horizon), fair weather.

Soft-looking or delicate clouds foretell fine weather, with moderate or light breezes; hard-edged, oily-looking clouds, wind. A dark, gloomy, blue sky, is windy; but a light, bright blue sky indicates fine weather. Generally, the softer clouds look, the less wind (but, perhaps, the more rain) may be expected; and the harder, more "greasy," rolled, tufted, or ragged, the stronger the coming wind will prove. A bright yellow sky, at sunset, presages wind; a pale yellow, wet. Thus, by the prevalence of red, yellow, or gray tints, the coming weather may be very nearly foretold; almost exactly, indeed, if coupled with the aid of instruments.

Small, inky-looking clouds foretell rain; light seed-clouds driving across heavy masses of higher cloud show wind and rain; if alone, they

may indicate wind only. High upper clouds crossing the sun, moon, or stars, in a direction different from that of the lower clouds or of the wind felt below, usually foretell a change of wind.

After fine clear weather, the first signs in the sky of a coming change are usually light streaks, curls, wisps, or mottled patches of white, distant clouds (*cirri* and *cirro-cumuli*), which increase, and are followed by an overcasting of murky vapor (the *stratus*) that grows into cloudiness (*cumulo-stratus*.) This appearance, more or less oily or watery, as wind or rain will prevail, is an infallible sign. Usually, the higher and more distant such clouds seem to be, the more gradual, but general, the coming change of weather will prove.

Light, delicate, quiet tints or colors, with soft, undefined forms of clouds, indicate and accompany fine weather; but gaudy or unusual hues, with hard, definitely outlined clouds, foretell rain, and probably strong wind. Misty clouds forming or hanging on heights, in case they remain, increase, or descend, show wind and rain coming. If such clouds rise or disperse, the weather will improve or become fine.

When sea birds fly out early, and far to seaward, moderate wind and fair weather may be expected; when they hang about the land, or over it, sometimes flying inland, expect a strong wind, with stormy weather. When birds of long flight, rooks, swallows, or others, hang about home, and fly up and down, or low, rain or wind may be expected. Many other creatures besides birds give indications by their actions of approaching rain or wind. When animals seek sheltered places, instead of spreading over their usual range, and when pigs carry straw to their sties, an unfavorable change may be expected. [The frequent whistling of quails in summer, and the flight and screaming of the nighthawk early in the afternoon, are very sure indications of the near approach of rain.]

Remarkable clearness of atmosphere near the horizon, distant objects, such as hills, unusually visible, or raised (by refraction), and what is called a "good hearing day"—sounds being heard with unusual clearness, or to unusual distances—are among the signs, usually, of rain, sometimes, of wind. Much refraction (*mirage*) indicates an easterly wind. When, during a calm, smoke ascends with difficulty or to but little height, or settles, an unfavorable change is indicated.

Dew is an indication of fine weather; so is fog. [Not always: in this country, very heavy dew or white frost, especially if repeated, is almost a sure presage of rain; and fog may precede, or occur during, long rains.] Dew never, and fog seldom, occurs under an overcast sky, or when there is much wind. Fog is occasionally rolled away by wind, but seldom or never formed while it is blowing. More than usual twinkling of the stars, indistinctness or apparent multiplication of the moon's horns, haloes, "wind-dogs" (fragments of rainbows, or de-

tached clouds), and the rainbow, are more or less significant of increasing wind, if not of approaching rain, with or without wind.

Near land, in sheltered harbors, in valleys, or over low ground, there is usually a marked diminution of wind, during part of the night, and a dispersion of clouds. At such times, an eye on an overlooking height may see an extended body of vapor below (condensed by the cooling of night), which seems to check the wind. Finally, along with the other indications of change or continuance of the wind or weather, the dryness or dampness of the air, and its temperature, are never to be overlooked.

*Cyclones and Anti-Cyclones.*—The occurrence of cyclones, or rain and wind storms of several hundred miles diameter, which at once advance and rotate or whirl, is now pretty generally received as a fact by theoretical and practical meteorologists. Prof. Dove lays it down as generally true that when the air is indraughted from all or many sides to a stormy centre of light ascending currents, the resulting wind at the surface takes a movement in cyclonic curves (retrograde in northern latitudes, or in a direction the reverse of that of the hands of a watch, face upward); and that such winds are also produced when the equatorial current forces its way from S.W. against a mass of quiescent air. Mr. S. A. Rowell, before the British Association, 1862, presented what he considered objections to the cyclone theory; among them, the great unlikelihood of the rotation of an extremely broad and thin disc of air, the greatest thickness not exceeding the one or two miles of height through which only such turning current can be formed, and of the supposition that this revolving disc will also make its way forward through the densest parts of the atmosphere. In truth, however, this is not a question to be settled by likelihood, but rather by actual record and comparison of the places of storms and the directions of winds in different parts of the area they cover, at successive hours and days through their continuance; and evidence of this sort appears now to be decidedly in favor of the cyclone theory.

Mr. Galton, in a paper very recently read before the Royal Society, asserts that the occurrence of direct rotations of vast discs of air (that is, those turning in the direction opposite of that of the cyclone, namely, in that of the hands of a watch) are also common, being due to an opposite cause, namely, heavy descending currents over a considerable area nearly calm; and these winds he proposes to name anti-cyclones. A comparison of simultaneous charts of the weather of Europe, over 98 epochs of observation, compiled and shortly to be published by him, showed an almost invariable deflection of the wind currents in the course above mentioned (the same as that required in Dove's law of the rotation of the wind), with occasional instances of strongly marked and complete anti-cyclones. Indeed, an anti-cyclone can feed a cyclone at any part of the cir-

cumference of the latter, and without abruptness, just as two wheels by contact at their circumferences turn in opposite directions. The localities of highest and lowest barometer, at the same time, were separated in his charts by distances of from 1,000 to 2,000 miles; and he concludes that whenever there are limited areas of very high and low barometer at distances not exceeding the above, a line drawn from the former to the latter will be cut in all cases by winds coming from the left. He argues that, as the area of the cyclones is one of storm and rain, so that of the anti-cyclones is an area of general calms and fair weather.

**METHODISTS.** The Methodists are by far the most numerous religious denomination of the United States, and were divided, in 1862, into the following branches: 1. The Methodist Episcopal Church, with a membership of 942,906 (which, however, includes the Missionary Conference of Germany and the Liberia Conference); 2. The Methodist Episcopal Church South, with about 700,000 members. 3. The American Wesleyan Methodists, with about 21,000 members. 4. The Methodist Protestant Church, with about 90,000 members. 5. The African Methodist Episcopal Church, with about 20,000 members. 6. The African Methodist Episcopal Zion Church, with about 6,000 members. 7. The Evangelical Association, also called German Methodists, with 46,000 members. 8. The Free Methodist Church (originated in 1859), with a few congregations in New York and other Northern States. 9. The Independent Methodist Church, the first congregation of which was organized in 1860, in New York city. 10. The Central Methodist Episcopal Church, consisting of three churches in Baltimore, which separated from the Methodist Episcopal Church, on account of the changes made by the last General Conference of the Church in the book of discipline.

The Methodist Episcopal Church, the most numerous of these denominations, suffered during the year 1862 a decrease of 45,617, the decrease of members being 22,045 and that of probationers 23,573. The largest decrease was shown in the border Conferences, which had been during the year the seat of the war, and part of which had even been under the control of the Confederates. Four of these Conferences, the Missouri and Arkansas, the Baltimore, the East Baltimore, and Western Virginia conferences, showed alone a decrease of 10,161 members. A considerable increase was shown by the following Conferences: Nebraska, North Indiana, East Maine, East Genesee, Minnesota, and Wisconsin.

Six of the fifty-one Conferences of the Methodist Episcopal Church, viz.: Missouri and Arkansas, Baltimore, East Baltimore, Philadelphia (embracing the churches of Delaware), Kentucky and Western Virginia, are wholly or partly in slaveholding States. In one of these Conferences—Baltimore—a great dissatisfaction was manifested with a change made by the

last General Conference in 1860, respecting the position of the church on the Slavery question. A convention of laymen of the Conference, held at Staunton, Virginia, in March, 1861, simultaneously with the annual meeting of the Conference, adopted an address to the Annual Conference, in which they declared in favor of proclaiming the Baltimore Conference and those other Conferences which voted with her against the New Chapter on Slavery, "to be the Methodist Episcopal Church, and that the General Conference and the majority of the Church have ceased to be any portion of said church." The Annual Conference, in conformity with the memorial of the laymen, passed a series of resolutions, declaring that the General Conference "by its unconstitutional action has sundered the ecclesiastical relation which had hitherto bound the Conferences together as one church, as far as any act of theirs could do so;" that the Baltimore Conference therefore "declares itself separate and independent of the General Conference, still claiming to be notwithstanding an integral part of the Methodist Episcopal Church;" that the Conference would however "reunite with the other Conferences in the organization of another General Conference, if three fourths of the Annual Conferences should disavow the act of the General Conference of 1860 on the subject of slavery, and give thorough and satisfactory redress, by abrogating the New Chapter, by transferring the subject of slavery to the exclusive jurisdiction of the Annual Conferences where it exists, and by placing a fair proportion of the periodicals of the church under the charge and the direction of said Conferences." These resolutions were passed by a vote of 87 (of whom 58 were stationed in Virginia) in their favor, 45 refusing to participate in the proceedings as illegal, and 88 being absent. The actual secession of the Baltimore Conference was, however, prevented by the outbreak of the civil war, and when the Annual Conference met again in March, 1862, but few of the Virginia members were present, and a considerable majority of the Conference, though renewing their protest against the New Chapter, passed resolutions of loyalty to the Methodist Episcopal Church. Five ministers withdrew, in consequence, from the jurisdiction of the Conference, and established in the city of Baltimore three independent societies, which were organized under the name of the Central Methodist Church. No trustworthy information had been received up to the end of the year 1862 as to what the preachers in the Virginia portion of the Baltimore Conference would do. About forty of them assembled at Harrisonburg on the second Thursday in March, but no decisive resolutions were passed.

With the exception of the Baltimore Conference, all the Conferences, both of the border slaveholding and free States, passed resolutions expressive of loyalty to the National Government, in most instances with entire una-

nimity. These resolutions, with only a few exceptions, also expressed a wish for the speedy overthrow of slavery, and approbation of the President's emancipation policy.

One of the most important questions which agitated the church during the year 1862 was that of lay delegation. In accordance with a resolution passed by the General Conference, in 1860, the vote of the ministers and of the laity of every Annual Conference was taken on the subject, and the returns gave the following result: Ministers (in 48 Conferences), for lay delegation, 1,386; against, 3,025; laity (in 46 Conferences), for, 27,984; against, 46,405. The lay vote had not been taken up to the close of the year in the Baltimore and Kentucky Conferences. The ministerial vote shows a majority for the measure in only 4 Conferences: viz., Philadelphia, East Genesee, Genesee, and Oregon; and the vote of the laity in 12 Conferences; Philadelphia, New York, New York East, Providence, New England, New Hampshire, Black River, Oneida, East Genesee, Genesee, Wyoming, California.

The Methodist Episcopal Church South was reduced by the war to an unfortunate condition. The General Conference of the church, which was to have met during the year 1862 at New Orleans was, indefinitely postponed. The book concern at Nashville, after the occupation of that city by the Federal troops, was entirely broken up. The missionary treasury was reported to be without funds to meet outstanding drafts. The organs of the church published in St. Louis, San Francisco, New Orleans, and Memphis, and probably nearly all the other denominational papers, were discontinued. An informal meeting of 8 of the 6 bishops of the church, together with several members of the board of managers of the Missionary Society, and several ministers of the Georgia Conference, was held at Atlanta, Georgia, in April, 1862, when it was resolved to apportion the support and travelling expenses of the bishops among the several Annual Conferences. In some of the border States the church was greatly disorganized, as a considerable portion of the members showed themselves decidedly opposed to the secession doctrines which were advocated by nearly all the church organs. In Missouri and western Virginia a number of members joined the Methodist Episcopal Church. In Missouri a convention of Union members of the Methodist Episcopal Church South was held on August 6, which adopted an address to the Missouri Conference of the denomination, announcing their intention to remain in the church only if the church would be loyal to the Government of the United States. It is believed that a considerable portion of those members of the church will soon join the Methodist Episcopal Church. From Kentucky it was reported that there were 36 of the travelling preachers in the Louisville Conference, and a goodly number in the Kentucky Conference,

who were determined to adhere to the Federal Union, and many of whom intimated that if the separation of the States should be final, they would be inclined to return to the Methodist Episcopal Church. It was also ascertained that the senior bishop of the church, Bishop Soule, was opposed to secession. In California and Oregon the Southern Methodist organization is threatened with utter extinction. The organ of the denomination has been discontinued, the book depository in San Francisco closed, an institution of learning, which was to be made a first class college, is only a small preparatory school, and toward the close of the year it was expected that Southern Methodism, as an organization, would soon cease to exist in the Pacific States.

In the Methodist Protestant Church the war has developed the breach which has always existed between the Northern and Southern Conferences with regard to the slavery question, and the denomination has actually split into two organizations. All the Conferences in the free States, as well as that of West Virginia, have indicated their loyalty by taking strong and firm ground in support of the Federal Government. They also, with only one exception, have expressed themselves in favor of a restoration of the General Conference. The Conference of West Virginia has, in every respect, fully identified itself with that of the free States.

The British possessions in North America have offshoots of the several Methodist organizations in Great Britain, as well as the Canada Conference of the Methodist Episcopal Church, which in the Episcopal form of church government agrees with the main branch of Methodism in the United States. In Canada, according to the official census of the population, taken in 1861, the Methodists occupy the third rank numerically, after the Roman Catholic and Anglican churches, treading very closely on the Church of England, which only outstrips them by 2,733. Both in Lower and in Upper Canada the Methodists have gained, in the interval between the two last enumerations (1852 and 1861), relatively to all other denominations. In Lower Canada they numbered 21,183 in 1852, or 2.88 per cent. of the population: and 80,582 in 1861, or 2.75 per cent. In Upper Canada they numbered 207,656 in 1852, or 21.81 per cent.; and 341,572 in 1861, or 24.47 per cent. In the whole province they numbered 228,839 in 1852, or 12.42 per cent.; and 372,154 in 1861, or 14.85 per cent. of the increased population. Among the several Methodist denominations, the New Connection Methodists showed the greatest progress. They numbered, in 1852, 10,989; and, in 1862, 29,492, giving an increase of about 170 per cent. during the ten years.

In South America, the Methodist Episcopal Church of the United States has a flourishing mission at Buenos Ayres, numbering, in 1862, 92 members.

In Hayti, the English Wesleyans sustain a mission which had, in 1862, 4 circuits, 4 chapels, 8 other preaching places, 6 missionaries, 10 other agents, 239 members, 16 members on trial, 265 scholars in schools, and an average attendance of 1,400 in public worship.

In the British portion of the West Indies, the Wesleyan Methodists have numerous churches in Antigua, St. Vincent's, and Demerara, Jamaica, Honduras, and Bahama, together with 84 missionaries and 48,719 members.

The main branch of Methodists in Great Britain, the Wesleyan Methodists, held, in 1862, their 119th Annual Conference in Camborne, Cornwall, on July 31 and the following days. It was presided over by the Rev. C. Prest. Of the "Legal Hundred" ministers who form the Conference, three had died during the year, and two had retired. The amounts raised during the year from all sources for the funds of the connection were as follows: foreign missions, £137,280; theological institution, £7,368; contingent, £14,825; general chapel fund, £6,151; education fund, £9,857; worn-out ministers, £12,987; Kingswood and Woodhouse Grove schools, etc., £14,211. The British Conference of Wesleyan Methodism comprises the churches of Great Britain, of Ireland, and numerous foreign missions, and in close connection with it are four other Conferences, viz., the French, Australasian, Canada, and Eastern British America Conference. The general statistics of Wesleyan Methodism, in 1862, are exhibited in the following table:

CONFERENCE.	Members.	On trial.	Ministers.
<b>I. British Conference:</b>			
Great Britain.....	325,256	25,608	1,110
Ireland.....	22,741	728	143
Foreign Missions.....	68,249	5,175	399
<b>Total.....</b>	<b>416,246</b>	<b>31,511</b>	<b>1,651</b>
<b>II. French Conference.....</b>			
	1,586	155	25
<b>III. Australasian Conference..</b>			
	86,307	6,514	150
<b>IV. Canada Conference.....</b>			
	50,841	4,064	375
<b>V. Eastern British America Conference.....</b>			
	15,389	1,448	99
<b>Total.....</b>	<b>519,969</b>	<b>48,692</b>	<b>2,809</b>

The New Connection Methodists, who were formed in August, 1797, of about 5,000 members, numbered at the Conference, in 1862, 12 districts, 56 circuits, and 3 missions, 127 preachers, and 24,271 members; in Ireland 7 circuits and stations, 7 missionaries, and 782 members; and in Canada 82 circuit preachers, and 7,423 members. There has been, during the year, an increase of 1,539 members in England, and a decrease of 16 in Ireland.

The Bible Christians, who originated in 1818, held, in 1862, their 44th Conference at Portsmouth, on the 30th of July. This, although one of the smallest, is, in proportion to its numbers, the most flourishing branch of the great Methodist denomination in that country. The number of travelling preachers is 207, four of whom are women. Foreign missions, in the strict sense of the word, the Bible Christians

have none. The home circuits are 82; the home mission stations, 27; those in Prince Edward's Island, 6; in Australia, 18. They had, in 1862, 25,392 members, and 32,658 scholars.

The Primitive Methodists, according to the minutes of the 43d Annual Conference, had in 1862, 776 travelling preachers, male and female, 2,519 connectional chapels, 3,542 rented chapels, 141,185 members (increase 5,791), 2,322 Sunday schools, 189,057 scholars (increase 8,993), including the Home and Foreign Missions.

The United Methodist Churches, who were formed in 1857, by the amalgamation of the association (the secession headed by Dr. Warren, 1835, and some who seceded, principally at Leeds, in 1829), and the seceders of 1849 reported, in 1862, 60,880 members, and 122,320 scholars.

The yearly delegate meeting of the Wesleyan Reform Union was held in London; August 19 and 20. Thirty-five delegates were in attendance. The following is a summary of the detailed circuit returns: chapels and other preaching places 323, preachers 685, members in society 11,355, Sunday schools 179, Sunday scholars 20,754.

The French Wesleyan Conference—the statistics of which have already been given—began its annual session at Nimes, on the 27th of June. It was reported that during the last two or three years the building of chapels has been begun, and that they are now quickly multiplied in all directions. There is also a considerable increase in the membership. It was determined by the Conference to extend the publication interests, to enlarge the organ of the denomination (the *Evangeliste*), and to publish several new works. The Government, during the last few years, has manifested a more friendly feeling toward the Methodist Church.

The German Annual Conference, which comprises the Methodist Churches of Germany and German Switzerland, and is in connection with the Methodist Episcopal Church of America, met at Ludwigsburg, Wurtemberg. This Conference comprises 15 missionary members in Conference, 1,753 members in full connection, 824 members on trial, 8 churches with parsonages, 4 districts, 19 circuits. The Mission Institute at Bremen has already sent out 18 ministers, and had, in 1862, 8 students. Besides this Conference of the Methodist Episcopal Church, the Wesleyan Methodists of England sustain a mission in Germany, which, in 1862, had 4 numbers of circuits, 2 chapels, 71 other preaching places, 6 missionaries, 47 subordinate agents, 416 members in full connection, 137 members on trial, 30 scholars, and 2,400 attendants on public worship. The Evangelical Association (German Methodists) of the United States have also established a mission in southern Germany.

The Scandinavian missions of the Methodist Episcopal Church in Denmark and Norway had, in 1862, 4 churches, 911 members, and 5 Sunday schools, with 193 children.

The foundation of Methodist missions has also been laid in Spain, Italy, and Bulgaria. In Spain the Wesleyan Methodists of England had, in 1862, 1 chapel, 3 other preaching places, 2 missionaries, 20 subordinate agents, 51 members, 6 members on trial, 267 Sunday scholars, and 650 attendants on public worship. A mission in Italy was begun by the Wesleyan Methodists of England in 1862; the nucleus of a congregation was formed in Parma, and a literary institution opened in Milan. In Bulgaria the Methodist Episcopal Church has had, since 1857, a mission, which now comprises three stations, Tirnooa, Shumla, and Tultoha. At the latter place there are 4 members, 2 day schools, with a regular attendance of about 70 children, 2 Sunday schools, with a regular attendance of about 50 children. The missionary of this place is chiefly laboring among the Melokans, a Russian sect, and the Germans in Tultoha, in the neighboring villages, and in southern Russia.

In Asia the Wesleyan Methodists were supporting, in 1862, the following missions: southern Ceylon (Singhalese), with 22 missionaries, 1,736 members, 427 members on trial; northern Ceylon (Tamil), 23 missionaries, 452 members, 18 members on trial; in India 17 circuits, 22 chapels, 25 other preaching places, 36 missionaries, 156 subordinate agents, 890 members, 40 members on trial, 2,979 scholars, 4,115 attendants on public worship; in China 1 missionary, 30 members. The Wesleyan printing establishment at Colombo, Ceylon, issued and distributed every month 10,000 copies of tracts, periodicals, and portions of holy Scriptures among the native Singhalese. At the printing establishment at Bangalore, southern India, the printing of a quarto edition of the New Testament in Canarese has been completed, and the whole Bible is now, for the first time, available in this language. The same establishment has issued 80,000 Canarese tracts, 15,000 English and Canarese school books, and several other books. The Methodist Episcopal Church has a mission in China, the centre of which is at Fuhchau, with 25 missionary agents, American and Chinese, and 87 members; and another in India, which had, in November, 1862, 21 missionaries, 12 native preachers, 178 communicants, 29 schools, and 1,224 scholars.

In Africa the Wesleyan Methodists of England have missions at the Cape of Good Hope, Kaffraria, and Bechuana, Natal, Sierra Leone, Gambia, and Gold Coast, together with 80 missionaries, and 16,425 members. They have printing presses at Mount Coke, British Caffraria, at Sierra Leone, and at Thaba Unchu, in the Bechuana country. The number of pages printed in the latter of these establishments amounted to over 300,000. The Methodist Episcopal Church of the United States has, in Africa, 20 missionaries and 1,473 members.

The Australasian Conference of Wesleyan Methodists met in January, 1862, at Adelaide. The increase of members in the colonies has

been 1,187, besides 1,059 on trial. In the mission districts there has been an increase of 5,455, the largest being in Fiji, and the smallest in Zealand, where the relations of the Maori and European populations are still in an unsettled state.

MEXICO, a North American Republic. Area, 888,028 square miles. Population in 1858, 8,283,088. President, Benito Juarez.

The Annual Cyclopædia for 1861, in its account of Mexico, closes with the military occupation by the allied English, French and Spanish forces, of Vera Cruz and the fortress of San Juan d'Ulloa, which had been yielded to them by the Mexicans without a conflict, the latter retiring a short distance into the interior and cutting off their supplies. Vera Cruz and the low lands in its vicinity have a deadly climate, especially for unacclimated foreigners; and between that city and the Mexican capital rises an elevated country, difficult of passage and void of water, food, or forage for the enemy. To traverse this route with a small force (the united forces of the allies did not exceed 25,000 men, more than half of whom were sailors), surrounded at every step of the route, was impracticable. To remain at Vera Cruz, which had been their previously declared policy, was to expose themselves to almost certain death from the terrible *vomito* or yellow fever always prevalent there during the hot season, and which threatened to be unusually virulent the ensuing season. At the beginning of the year the Mexican President, Juarez, had appealed to the Mexicans of all parties, forgetting their party differences for the time, to unite in expelling the hated invader from their soil, and his appeal had been listened to with favor. All classes, even the most strenuous of the *Moderados*, or clerical party, united with the most advanced of the *progressistas* or liberals, in defence of the republic, and despite the poverty of the country from years of anarchy and revolution, they were capable of offering a formidable resistance to the invaders. To add to the difficulties of the allied forces, they soon began to quarrel with each other. General Prim, the commander of the Spanish forces, finding that the proposition of Spain to have a Bourbon placed upon the throne of Mexico when conquered, was received with disfavor by the French, who wished for an Austrian prince, became convinced that the claims of Spain could be settled by negotiation. President Juarez had at the commencement of the year demanded that the allies should reëmbark the bulk of their forces at Vera Cruz, and retaining only a body guard of 2,000 men, should meet him with a similar guard at Orizaba, a few leagues in the interior, for a negotiation; and this proposition being declined, he had sent a skilful diplomatist, Senor Zamacona, to Vera Cruz to ascertain what was the prospect for an arrangement with the allies. This statesman soon comprehended the position of

affairs between the Spanish General and the French Admiral, and arranged for an interview between General Prim and the Mexican Minister of Foreign Affairs, Senor Doblado. This interview took place on the 15th of February, at the little village of Soledad, upon the road between Cordova and Orizaba, and resulted in the arrangement known as the Convention of Soledad. This convention evinced the high diplomatic ability of the Mexican minister. It allowed the allies to occupy healthy positions in *Tierras Templadas*, or more elevated regions at some distance from the coast; but at the same time it postponed the period for commencing negotiations to the 15th of April, and thus indirectly recognized, which the allied powers had before refused to do, the government of Juarez, as the *de facto* Mexican government, gave him time to collect his forces, and delayed the action of the allies to a period when the *vomito* would prove his powerful ally, while it afforded the means of promoting the discord already existing between the leaders of the allied forces. General Prim signed this convention in behalf of Spain, and presented it to the other leaders, for their acceptance. The English minister, Sir Charles Wyke, who was with the English forces, inclined to accept the convention, as a preliminary to separate negotiations for England alone, though not altogether satisfied that Gen. Prim should have negotiated it alone, but the French Admiral opposed it, and though provisionally accepting it so far as to lead his troops into the interior referred it to the French government, which wholly disapproved it, and refused to be bound by it. One object, at least, of the astute Mexican statesman was accomplished by it, the feud between the allies became every day more open, and presently they separated, the English occupying Cordova, the French Tehuacan, and the Spaniards Orizaba, and their action and intercourse with the Mexicans gradually became entirely independent of each other. Sir Charles Wyke made an arrangement for the payment of the English claims, which were much larger than either of the others (*see* Annual Cyclopædia, 1861), by receiving a portion of the customs, and Gen. Prim made some composition of the Spanish claim.

Juarez, meantime, understanding their differences, and foreseeing that he should have only the French to fight, took a more decided position, increased his forces, proclaimed that those Mexicans who took sides against the government should be regarded as traitors and punished as such, and his commanding general Zaragoza, having taken General Robles, a Mexican officer, who had adhered to Miramon, and had endeavored to overthrow the government of Juarez, a prisoner, tried him by martial law, and executed him at once, almost within sight of the French camp. During the first days of March, Gen. Almonte, another Mexican officer, formerly a president of the republic, but who had been a bitter opponent of

Juarez, and had, while in Europe, advocated the overthrow of the Mexican government, and the placing of the Archduke Maximilian upon the throne of the kingdom to be established by the allies, arrived at Vera Cruz, having a letter from the emperor Napoleon III, and proceeded to the French camp at Tehuacan. Juarez demanded that he should be surrendered to his officers as a traitor and outlaw. The French Admiral refused peremptorily to give him up; the Spanish and English commanders insisted that it was his duty to do so. The French Admiral, finding that his refusal was regarded as a violation of the armistice by the Mexicans, fell back to Chiquihuite, according to the terms of the convention of Soledad, which the other commanders contended he had no right to do without consulting with them. Angry interviews resulted, and at length, after a final conference not of the pleasantest character, on the 8th of April, 1862, at Orizaba, the Spanish and English commanders returned to Vera Cruz with their forces, embarked on board their transport ships and left the French alone in Mexico. The course adopted by these commanders was subsequently approved by their respective governments.

No sooner were the allies of the French forces gone, than Senor Almonte, who up to that period had remained quiet, stirred up a few malcontents to make *pronunciamentos* in his favor at Cordova and Orizaba, and took advantage of these to proclaim himself the dictator of Mexico, and to organize around him a band of officers composed of those who had been traitors to their country. He collected also a little troop of soldiers, which he put under the command of one of his creatures, a General Galves, and as Miramon had previously done, commenced a course of plunder, outrage, and murder, and by his subsequent course in contracting loans in the name of his pretended government, and his cruelties toward the Mexicans who have fallen into his hands, he has greatly embarrassed his French allies, and made them so obnoxious to the Mexicans, that they have greatly regretted their connection with him.

After the departure of the English and Spanish forces, the Admiral De la Graviere was superseded by General Lorencez, who brought reinforcements to the French forces, and who, pushing forward from Chiquihuite toward Puebla, and deceived by the promises of Almonte and his followers, that there was a large party in that city who would revolt in favor of the French, suffered himself to be persuaded to attack it without sufficient artillery, met with a mortifying and disastrous defeat, and was compelled to fall back upon Orizaba. Here he remained, urging the French Government to send him speedy reinforcements and supplies, as all other sources of supply were cut off, and even much of those sent to him from Vera Cruz (where the fleet lay), was interrupted by the Mexican guerillas. On the 18th of May, one of his battalions repulsed a Mexican force

which sought to prevent a junction of his forces with those of Gen. Marquez, one of Almonte's generals. On the 12th of June, General Zaragoza, the Mexican commander of the forces of Juarez, arrived at Tecamalucan, about 7 miles from Orizaba, with a considerable force, and sent the same day a letter to Gen. Lorencez, representing the perils of his position and demanding his surrender; Lorencez made an evasive answer, and by two well-planned sallies, on the 13th and 14th of the month, defeated separately the corps of Ortezca, and that of Zaragoza, and compelled their retreat with a heavy loss, estimated by the French at 5,000 or more, killed, wounded and missing. From this time until October, there were no battles; but the French army suffered terribly from the vomito, losing nearly 1,000 men out of about 5,000, and were so constantly harassed by the guerillas, who cut off their supplies, that they were at times reduced almost to starvation. Early in October, Gen. Forey arrived with nearly 35,000 fresh troops, a part of them negro troops from Egypt, loaned to the emperor by Said Pasha, the Viceroy of Egypt; but the Mexicans, nowise daunted by this display of force, were working with great diligence to make Puebla impregnable, and harassed the French constantly by their guerilla attacks. Gen. Forey moved forward on the route to Puebla in November, but soon found that his communication with Vera Cruz, which was indispensable for his supplies, was cut off, and it was only by stationing a strong body of troops at La Soledad that he could keep it open. His vanguard, 4,000 strong, under Gen. Berthier, were surprised, before reaching Puebla, and over 2,000 killed and wounded. The main army approached Puebla, but were repulsed with heavy loss. Tampico and Jalapa, the former an important port, which had been in possession of the French forces, were evacuated in the latter part of December, in order to concentrate his force on the line from Vera Cruz to Puebla. The small-pox, in its most malignant form, had broken out among the French troops at Vera Cruz, and the French general found himself compelled at the beginning of 1863 to call for 10,000 more troops.

The position of the Government of the United States on the affairs of Mexico was thus described by the Secretary of State in a circular dated March 8, 1862:

The President has relied upon the assurance given his Government by the allies, that they were in pursuit of no political object, but simply the redress of their grievances. He entertains no doubt of the sincerity of the allies; and if his confidence in their good faith had been disturbed, it would be restored by the frank explanations given by them, that the Governments of Spain, France, and Great Britain have no intention of intervening to procure a change in the constitutional form of government now existing in Mexico, or any political change which should be in opposition to the will of the Mexican people. In short, he has cause to believe that the allies are unanimous in declaring that the revolution proposed to Mexico is solely prompted by certain Mexican citizens, who are now in Europe.

MICHIGAN, one of the northwestern States, bounded on the west in part by the lake of the same name, increased in population during the ten years preceding 1860, the number of 351,459. For the further details of the census of 1860, which were published in 1862, relative to Michigan, see UNITED STATES.

The Legislature of Michigan assembled on the 1st Wednesday of January, 1862. It had been elected on the 1st Tuesday of November preceding. The members were divided as follows:

	Senata.	House.	Total.
Republicans .....	18	63	81
Democrats .....	14	37	51

On the 18th of January, the following resolutions were adopted, as expressing the prevailing opinion of this body, and subsequently laid before Congress:

*Whereas* the Government of the United States is engaged in putting down a causeless and wicked rebellion against its authority and sovereignty, inaugurated by ambitious men to obtain political power—a Government, the safety and perpetuity of which must ever rest upon the loyalty of its citizens, and in an adherence to the Constitution; and whereas the welfare of mankind, the usefulness and power of the nation, are involved in the events and issues of the present conflict, therefore,

*Be it resolved*, That Michigan, loyal to herself and to the Federal Government, reaffirms her undying hostility to traitors, her abiding love for freedom, and her confidence in the wisdom and patriotism of the national Administration.

*Resolved*, That the people of Michigan deem it the imperative duty of the Government to speedily put down all insurrection against its authority and sovereignty, by the use of every constitutional means, and by the employment of every energy it possesses; that Michigan stands firm in her determination to sustain, by men and treasure, the Constitution and the Union, and claims that the burden of loyal men should be lightened, as far as possible, by confiscating, to the largest extent, the property of all insurrectionists; and that as between the institution of slavery and the maintenance of the Federal Government, Michigan does not hesitate to say that in such exigency slavery should be swept from the land, and our country be maintained.

The citizens of the State were divided into two parties—the republicans and the democrats; the latter were designated by some as "Unionists," meaning by that all who were in favor of preserving the Union, but opposed to the Administration. The democratic party held a convention at Detroit, on the 5th of March, and passed a series of resolutions, but postponed the nomination of any candidates for the election in November:

The resolutions were expressive of the position of the democracy of Michigan, in the present crisis, promising to support the Government in all constitutional means to suppress the rebellion, and opposing the termination of the war until all resistance to the Government everywhere ceases.

Abolitionism was strongly denounced as equally guilty with Southern secessionism, and the speedy extinguishment of both was hoped for.

Also approving the modification of Gen. Fremont's proclamation, and of Secretary Cameron's report, and the appointment of the present Secretary of War, as indications that the President would adhere to the Constitution.

Also denouncing corruption and extravagance, and

demanding honesty and economy in the administration of Government.

Subsequently the same party nominated for governor ——— Stout, with candidates for State officers. The principles upon which the election was based will be perceived by the foregoing, and by reference to the resolutions adopted by the democratic conventions of Indiana and Iowa.

The republican party nominated for reelection for governor Austin Blair, and candidates for State officers. The general principles by which they were influenced in voting can be seen with sufficient clearness by reference to the resolutions of the Illinois republican convention, and by those above mentioned, subsequently adopted in the Legislature of Michigan.

At the election on the second Tuesday in November, the votes of the citizens for governor were cast as follows:

	1862.	1860.
Republican .....	68,716	87,806
Democratic .....	62,102	67,221
Majority .....	6,614	20,585

Six republican members of Congress were chosen, for whom the vote was as follows:

	Republican.	Democratic.
1st District .....	13,400	13,208
2d " .....	14,147	11,885
3d " .....	12,317	11,467
4th " .....	10,013	7,308
5th " .....	10,432	10,696
6th " .....	7,879	7,840

The number of troops which entered the Federal army from the State is nearly 50,000; of whom 24,097, embracing eighteen regiments of infantry, one regiment and one company of engineers, three regiments of cavalry, six companies of sharpshooters, one company of light and six of heavy artillery, and thirteen companies of infantry, and two squadrons of cavalry, enlisted in other States, took the field in 1861.

The length of railroads in the State exceeds 800 miles, at a cost of construction of over \$31,000,000. Three principal lines, connecting the eastern portion of the country with the Upper Mississippi valley, cross the State. These are called the Southern, Central, and Detroit and Milwaukee. A fourth, intended to connect by steam ferry with the Sheboygan and Fond du Lac of northern Wisconsin, has been commenced. The State has one canal, which extends around the falls of St. Mary, and connects Lake Superior with the other lakes. (See page 230.)

No State has an institution so largely endowed or with so complete an organization as the University of Michigan. It has not only the faculty usually found in colleges in this country, but a corps of legal and medical professors besides others of the higher sciences and the fine arts. An entrance fee of \$10 is the only payment required of the student. There are also the Kalamazoo College, under the direction of the Baptist denomination; Albion College, under the Methodist denomination;



and Hillsdale College, under the Free Will Baptists. The State has a primary school fund exceeding \$1,698,861, a university fund exceeding \$500,000, and the normal school fund not far from \$20,000. The number of children attending school in the State, in 1861, was 202,504 out of 252,533.

The salt manufactures in the State, in consequence of the high price of the article during the last year, became rapidly developed. Saginaw is the principal town in the region, and the salt fields extend from the bay westward between forty and fifty miles, to the point where the Chippewa river passes into the Tittibawassee, and even beyond. In breadth they are about thirty miles. This whole district forms a basin constantly filling with brine 85 to 92 per cent. Boring is pushed to the depth of eight hundred feet, and the supply continues inexhaustible. The brine, although containing impurities, compares well with the Onondaga and Kanawha brines. This portion of the country is also a great lumber region, which is inducing a rapid settlement. Salt docks and lumber yards alternate for twenty-five miles up the Saginaw river. About six hundred thousand barrels were manufactured during the year. The old kettles and furnaces are gradually giving way to the new process of evaporating by steam in large vats, which produces a better quality of salt at a reduced cost. The geological survey of the State has also developed vast treasures of iron, copper, lead, coal, marble, and gypsum. The debt of the State on July 1st, 1862, was as follows:

"Adjusted bonds," 6 per cent., due in 1863. . . . .	\$1,744,185 00
Full paid "Five Million Loan," 6 per cent., due in 1863. . . . .	177,000 00
Part paid "Five Million Loan," when funded, due in 1863, will be. . . . .	88,814 00
"Renewal Loan," 6 per cent., due in 1878. . . . .	216,090 00
"Temporary Loan," 7 per cent., due in 1878. . . . .	50,000 00
Internal improvem't warrant bonds, on demand. . . . .	50 00
Sanit Canal bonds, 6 per cent., due in 1876. . . . .	100,000 00
War loan bonds, 7 per cent., due in 1886. . . . .	605,500 00
Internal improvem't warrants, due on demand. . . . .	8,592 88
Total. . . . .	\$2,979,781 88

MINNESOTA, one of the northern central States of the Union, enclosing in its boundaries the head waters of the Mississippi river, the Red River of the North, and the St. Louis, the highest source of the St. Lawrence; area, 83,531 square miles; population, in 1860, 173,855.

Minnesota, though one of the youngest of the sisterhood of States, having been organized as a territory in 1849, and admitted into the Union as a State in 1857, has exhibited great energy and enterprise. Its population is largely from New England, but considerable bodies of Germans, Norwegians, and Swedes have also settled in different portions of the State, attracted by its fine climate, and the productiveness of its soil. The population of some of the western counties is almost wholly German, while in the more northern counties the Swedes and Norwegians predominate.

The governor of the State is Alexander Ramsey, of St. Paul, who was chosen in Octo-

ber, 1861, and assumed office in January, 1862. His term expires in January, 1864. The secretary of State is J. H. Baker, of Blue Earth, elected at the same time and for the same term as the governor. At the election in October, 1862, a Legislature and two members of Congress were chosen. The political complexion of the Legislature elected was: senate, republicans, 16; democrats, 5. House, republicans, 29; democrats, 12; Union democrat, 1. The congressmen elected were William Windam, in the 1st district, majority, 2,940; 2d district, Ignatius Donnelly, majority, 2,010. Both are republicans.

The State has been very prompt in furnishing her quota of troops, having equipped and sent into the field before December 1, 1862, 11,887, including the first three months' regiment of 930 men. This amount is about 300 in excess of her quota on all the calls.

During the spring and early summer of 1862, reports from various sources reached the United States Government, indicating that the Indian tribes of Utah, Colorado, Dakota, and western Nebraska would ravage the Territories and frontier States. It was said that emissaries from the Southern Confederacy had been among them, stimulating them to rise and plunder and destroy the frontier settlements; and to encourage them in this movement, they were told that the United States Government was broken up by the South, and could make no resistance. Adventurers from Canada, too, had visited them in the early part of the year (when, in consequence of the Mason and Slidell affair, it was expected there would be a war with Great Britain), urging them to bring their furs across the boundary, and assuring them that they should be aided with money and arms to drive the Americans from their lands. The Indians while thus prompted to insurrection, by evil and designing men from both north and south of their hunting fields, had also many imaginary and some real grounds of complaint against the Indian agents sent among them by the United States Government. Some of these had proved unworthy of their trust; had swindled and defrauded the Indians, and had treated them with harshness; and though these were the exceptions, and perhaps rare exceptions, yet the delay in paying the Indian annuities, owing to the negligence of the Indian bureau, and the attempt on the part of some of the agents to pay them in legal tender notes instead of gold, which the Government had furnished, aroused distrust in the minds of the Red men, and led them to plot revenge.

The reports which reached the Department of the Interior had given rise to so much apprehension that the commissioner of Indian affairs published in the summer an advertisement warning the public of the dangers in taking the overland route to the Pacific.

Meantime the settlers in western Minnesota were entirely unsuspecting of danger. A large

proportion of these settlers were Germans, especially in Brown and the adjacent counties; a considerable number were Norwegians, and the remainder generally of American birth. Most of them had purchased considerable farms, and they had built up small but thriving villages throughout the tier of western counties. They were on terms of friendship with the Indians, and had no apprehension of any treachery from them.

Though an insurrection had been deliberately planned, there is reason to believe that the massacre was precipitated somewhat sooner than was at first intended. On the 17th of August, 4 drunken Indians, belonging to Little Crow's band of Sioux, roaming through the country and becoming intoxicated on whiskey obtained from a white man, had a violent altercation with each other as to which of them was the bravest, and finally determined that the test of their bravery should be the killing of a white man. After committing several murders, and becoming somewhat sober, they fled to their village (Red Wood), and told their chief, Little Crow, who was one of the conspirators, what they had done. He, expecting retaliation for this outrage, at once determined upon commencing the intended attack, and on the morning of the 18th, with a force of 250 or 300 Indians, proceeded to the agency at Yellow Medicine and engaged in an indiscriminate slaughter of all the whites he could find there. Mr. Galbraith, the agent, was absent, having left home three days before, but his family were among the victims of this murderous assault. A force of 45 soldiers, sent up from Fort Ridgley at the first rumor of disturbance, were attacked by the Indians in ambush, and half their number slain. The marauders, flushed with success, pressed on with their work of death, murdering, with the most atrocious brutalities, the settlers in their isolated farmhouses, violating and then killing women, beating out the brains of infants or nailing them to the doors of houses, and practising every species of atrocity which their fiendish natures prompted. On the 21st of August, they had attacked New Ulm, a flourishing German settlement, the capital of Brown county, with a large force, had beleaguered Fort Ridgley, and were advancing upon other settlements. The only Indians engaged in these outrages were Sioux, and that portion of them under the special command of Little Crow. The Chippewas, the inveterate enemies of the Sioux, who had also a reservation in Minnesota, were uneasy, and assumed a threatening attitude. They alleged gross frauds on the part of their agent, who escaped from the reservation and committed suicide; but they took no part in the Sioux massacres, and, indeed, a few weeks later, offered to raise a force of their warriors to fight the Sioux, an offer which the Government did not think it wise to accept. On the first intelligence of this insurrection Governor Ramsey sent four companies of the 6th regiment of volunteers

from Fort Snelling, and, two days later, on fuller information, he sent forward seven companies more. Col. (now Gen.) H. H. Sibley, who had 30 years' experience among the Indians on the frontier, was placed in command. Mounted volunteers were also called for by proclamation to join these forces, and large numbers obeyed the call. The 8d Minnesota regiment, then on parole at St. Louis, was also ordered to report at St. Paul, and arrived there on the 4th of September.

On the 23d of August New Ulm was attacked by the Indians, who were repulsed after a severe battle by a body of the citizens under Judge Flandrau; but remained in the vicinity, intending to renew the assault. The next day, a detachment of Col. Sibley's troops relieved them from siege, and scattered the marauders; but as 2,000 women and children, who had fled in terror from the surrounding region, had taken refuge there, it was deemed best to evacuate the place, in order to convey them to a place of permanent safety. Fort Ridgley had been besieged for 9 days, and its little garrison had sustained and repelled three desperate attacks; they were relieved on the 26th by a force under the command of Lieut.-Col. McPhail, sent forward by Col. Sibley. Finding a large force concentrating on their trail in this direction, the greater part of the Indians proceeded northward, burning and killing everything in their way, toward Breckenridge, a town at the junction of the Bois des Sioux and Red River of the North, which at that point formed the west boundary of the State, massacred the settlers there, and crossing the river, laid siege to Fort Abercrombie in Dakota Territory. Intelligence of these movements having reached St. Paul on the 27th, two companies were forwarded at once to reinforce Fort Abercrombie. On the 3d of September a force of 150 Indians unexpectedly appeared at Cedar City, in McLeod co., in the centre of the State, attacked a company of volunteers there, and drove them to Hutchinson, while another band about as numerous attacked Forest City not far distant, and were repulsed by the citizens. A few days later, the Indians attacked Hutchinson, but were repulsed. Troops were sent at once to these points. Driven back here, the savages next extended their raid to Jackson, Noble, and Pipeston counties, in the S. W. part of the State on the border of Iowa, and Col. Flandrau, who had so valiantly defended New Ulm, was sent with 500 troops to protect that region. Gov. Ramsey had meantime apprised the United States Government of the condition of affairs, and had called the Legislature of Minnesota together to meet in extra session on the 9th of September. At their assembling, he laid before them, in his message, the circumstances of the Indian insurrection, and suggested the measures requiring their action, all of which were promptly passed. Meantime the Government had despatched Maj.-Gen. Pope to command in that department, and aid in sup-

pressing the insurrection. The Indians, finding a force greatly superior to their own ready to take vengeance on them for the terrible and dastardly outrages they had committed, began to withdraw from the region they had desolated. A force of 300 or 400 of them made two assaults, in September, on Fort Abercrombie, but were repulsed in both, the second time with heavy loss; the larger part of those who had invaded the central and southwestern portions of the State, fled toward the western border, but were overtaken and brought to bay at Wood Lake on the 22d of September, where after a sharp battle they were utterly defeated, and Little Crow, with his women and children, fled to the Yankton Sioux of Dakota Territory. About 500 Indians were taken prisoners, and 498 were tried by court martial, of whom 300 were sentenced to be hung. The President ordered, however, that only 38 of these should be executed, while the remainder were kept in confinement until further investigation could be had. One of the 38 executed on the 26th of December was a negro named Godfrey, who had been a leader in the massacres, and it was said had killed more than any one of the Indians.

The whole number of Indian warriors among the Minnesota Sioux did not exceed 1,000 or 1,200, and many of these had taken no part in the insurrection, so that probably the killed and captured constituted the greater part of the insurgents. This defeat and prompt arrest of the assailants carried terror into the hearts of the other Indian tribes in the vicinity, and though there have been occasional symptoms of uneasiness since that time among some of the Indians of that region, and the inhabitants of Minnesota cannot feel safe with such treacherous and bloodthirsty foes so near them, it is hardly probable that there will be another uprising for some years. The citizens of Minnesota are, not without cause, exceedingly desirous the Government should remove the Indians from their State.

The loss of life in this insurrection has never been accurately ascertained. Gov. Ramsey, in his message, stated it in round numbers at 800, a number undoubtedly larger than subsequent facts would sustain. Some of the writers from the region in which it occurred speak of it as not exceeding 100, which is probably as great an error in the other direction. 85 were buried at Yellow Medicine, nearly all of whom were horribly mutilated, and a considerable number at New Ulm, Breckenridge, Birch Coolie, Fort Abercrombie, Red Lake, Red Wood, and Wood Lake, and many more in the isolated farm houses in the extensive tract overrun by the savages. Probably not far from 500 in all lost their lives, either through the ferocity of the Indians or from the sickness, suffering, and starvation which resulted from their hasty flight from their homes. Between 20,000 and 30,000 persons thus fled for their lives, leaving everything behind them. A part have since return-

ed, others have found their way to their friends at the East, but for some months between 6,000 and 7,000, mostly women and children, were necessarily dependent upon charity. The people of the State contributed most liberally to their relief, and considerable sums were forwarded from other States. Gov. Ramsey urged upon the Government the forfeiture of the annuities of the Sioux for the benefit of these innocent sufferers, and the Secretary of the Interior warmly seconded the proposition, which indeed seems no more than justice. The loss of property was estimated at from \$2,500,000 to \$3,000,000, and the capital of annuity paid to the Minnesota Sioux, was \$2,000,000.

MISSISSIPPI, one of the cotton-growing States bordering on the east side of the Mississippi river, contained in 1860 a population of 353,901 whites, 778 free colored, and 436,631 slaves. The increase during the preceding ten years was 44,729. The white males in 1860 were 186,273; do. females, 167,626. The mortality during the year ending May 31, 1860, was 12,214. The most fatal diseases were consumption, fevers, and pneumonia. The value of industrial products was as follows: iron founding, \$147,550; lumber, \$2,055,396; flour and meal, \$541,994; cotton goods, \$261,135; woollen goods, \$184,500; leather, \$223,862. Total of all products, \$6,000,000. Value of real and personal estate, \$607,324,911. Lands improved, 5,150,008 acres; do. unimproved, 11,703,556. Cash value of farms and plantations, \$186,866,914; do. of implements and machinery, \$8,664,816. Some of the productions of the State were as follows: horses, 117,134; mules and asses, 112,488; milch cows, 207,134; working oxen, 104,184; other cattle, 415,559; sheep, 337,754; swine, 1,534,097. Value of live stock, \$40,245,079; wheat, 519,452 bushels; rye, 41,260; corn, 29,563,735; oats, 121,083; rice, 657,293 lbs.; tobacco, 127,736; cotton, 1,195,699 bales of 400 lbs. each; peas and beans, 1,986,558 bushels; potatoes, Irish, 401,804; do. sweet, 4,343,491; sugar, 244 hhds.; molasses, 8,445 galls. Miles of railroad in the State, 872; cost of construction of roads, \$2,020,000. The principal educational institutions of the State are the University of Mississippi, Mississippi College, Madison do., and Semple Broaddus College. The number of students in 1860 was 402. Some of these institutions are now closed.

The internal affairs of the State during the year 1862 present very few points of interest, except in connection with military affairs. The same indisposition to enter the army at the beginning of the year which existed in northern Georgia and Alabama, prevailed in Mississippi, and indeed through all the more southern States. The Legislature, at its session which commenced on Jan. 1, 1863, passed an act authorizing the governor to draft men to fill up the quota of the State for the Confederate service. Much objection was urged against this act, inasmuch as the members of the Legislature made them-

selves exempt from liability to the draft. A portion of the troops from Mississippi in the field at the close of the year were men enlisted for 60 days, who returned to their homes in January, after having suffered great mortality. Gov. Pettus, immediately upon the passage of the act, issued a call for 10,000 men to serve for two years. After stating the authority upon which the call was made, he thus proceeded :

Now, therefore, in virtue of the power thus vested in me, I issue this my proclamation, appealing to the patriotism of the people to evince their willingness to respond to every call their country may make upon them in the perilous crisis through which that country is called to pass. The power to draft has been conferred upon me by the Legislature, when volunteers failed to respond. I have too much confidence in the determination of the people of Mississippi to meet every responsibility and bear every burthen which may result from their severance of connection with an enemy intent upon their destruction, to believe that it will ever become necessary for me to resort to the exercise of that power. After the liberal contribution Mississippi has furnished in men and money for the prosecution of the war, the act authorizing this call would never have been passed if the necessity had not been most urgent.

I will therefore receive volunteers to the number of ten thousand, to serve for the term of two years. They are expected to bring arms with them, for which they will be allowed a fair value. To such as have no arms they will, as far as possible, be furnished. The time and places of rendezvous will be hereafter designated. Companies enlisting under this call will report to the adjutant-general at Jackson. Each company is required by the act to consist of sixty-four men rank and file.

JOHN J. PETTUS.

EXECUTIVE OFFICE, JACKSON, Jan. 31, 1862.

The scarcity of arms was such that volunteers were required, if possible, to furnish them. This call was followed by another from President Davis upon the governor for 7 regiments. While these affairs were in progress the advance of the Federal forces up the Tennessee and Cumberland rivers with the disasters to the Confederate cause which ensued, caused intense excitement. The most frantic appeals were made to the people, of which the following are examples :

The time is at hand when every man able to shoulder a gun has to go. The enemy is at our doors, and reverses are everywhere overtaking our arms. It is now to do, and do at once, or our cause is dead, and we are hopelessly lost.

Countrymen! fellow citizens! the time of peril has come. All that is dear to us is suspended upon the issue of arms. The sword is the arbiter, and the sword is alone potent when numbers are sufficient. Bear this truth in mind, and let none feel that they are exempt. Let us imitate the example of the ancients; when the cry was "Rome demands your help"—all, from the highest to the most humble, flew to arms. Or, if need be, in spirit at least, imitate the Carthaginian women, who cut off their hair to make ropes for their vessels. To arms, countrymen! We have nothing to hope for but victory or death.

The governor issued another proclamation calling upon every citizen capable of bearing arms to have his arms in readiness, and directing the boards of police in every county to appoint enrollers preparatory to drafting; and to establish gunshops for the repair of arms. By these efforts the larger portion of the military

strength of the State was brought into the field before the Confederate conscription act took effect. The battle at Shiloh now was fought, and the investment of Corinth and its evacuation followed, after which there was a cessation of active operations for some months. The important events will be found fully described under ARMY and NAVAL OPERATIONS. On June 17, Holly Springs was first occupied by Federal troops from the army of Gen. Halleck. This movement of troops in the northern part of the State and the defenceless condition of the counties on the river against the approach of the Federal gunboats caused the removal of the archives of the State from Jackson, the capital, to Columbus, near the border of Alabama. On June 26 the first attack on Vicksburg was made, which continued for 11 days. On Sept. 10, Natchez surrendered to the commander of the gunboat Essex, after a bombardment of two hours. The result of these operations was the firm occupation of the northern extremity of the State by the Federal forces, while the coast at the southern extremity was completely under the control of the Federal naval forces in the neighborhood. Two points on the Mississippi river within the state, Port Hudson and Vicksburg, were strongly fortified by the Confederate Government in order to preserve its communication with Texas, and to prevent the complete control of the river from falling into possession of the Federal Government. These were measures of the utmost importance to the Confederate States.

The crops of the State suffered severely from drouth in the month of August. The crop of corn, which had given promise of great abundance, was thereby very much reduced.

The governor of the State, John J. Pettus, who was in office at the time of the secession of the State, entered upon a second term of two years, which expires on June 1, 1864.

MISSOURI. The commencement of 1862 found Missouri in a more quiet condition than for many months previous, although, from the preparations making for warlike operations on either side, hostilities conducted on a larger and more systematic scale were anticipated. The army of the Confederate general, Sterling Price, lay around Springfield, in the southern part of the State, and was represented to be largely made up of Missouri militia, whose stability could not be depended upon in the event of a retreat. Along the southern and western frontiers the operations of guerillas caused occasional disturbance, but the central and northern parts of the State, together with the counties bordering on the Mississippi, remained tolerably quiet. The headquarters of the national army were at St. Louis, but considerable bodies of troops were distributed at various points between that city and Springfield, busily preparing for the campaign against Gen. Price.

At St. Louis early in the year, in consequence of complaints of disproportionate assessments having been made under the operation of Order

No. 24, levying assessments on wealthy secessionists for the support of loyal refugees, Gen. Halleck appointed a new board of assessors to revise the former list and make such modifications as circumstances demanded. Several secessionists having, nevertheless, failed to pay their assessments, he ordered their property to be seized under execution, with 25 per cent. additional to the assessment. One of the number, Samuel Engler, a prominent merchant of St. Louis, with a view of testing the legality of the transaction, caused a writ of replevin to be served on the provost marshal to recover the property taken from him; whereupon he and his attorney were arrested and lodged in the military prison.

By a special order, issued on the 23d, Gen. Halleck directed the provost marshal to send Engler beyond the lines of the department of Missouri, and to notify him that his return, without permission from the commander-in-chief, would subject him to punishment according to the laws of war. For the purpose of preventing any similar resistance to his orders, he reiterated his intentions in the following emphatic language:

Martial law having been declared in this city by authority of the President of the United States, all civil authorities, of whatever name or office, are hereby notified that any attempt on their part to interfere with the execution of any order from these headquarters, or impede, molest, or trouble any officer duly appointed to carry such order into effect, will be regarded as a military offence, and punished accordingly. The Provost Marshal General will arrest each and every person, of whatever rank or office, who attempts in any way to prevent or interfere with the execution of any order issued from these headquarters. He will call upon the commanding officer of the department of St. Louis for any military assistance he may require.

On the 9th of January the provost marshal general issued an order requiring all publishers of newspapers in Missouri, those of St. Louis excepted, to furnish him a copy of each issue for inspection, under penalty of having their papers suppressed. No little excitement was caused on the same day in the St. Louis Chamber of Commerce by the refusal of the secession members, who were in the majority and had just elected officers of their own views, to admit a number of Union applicants for membership. The consequence was the withdrawal of the Union members and the establishment of a Union Chamber of Commerce.

The indication of latent sympathy with secessionism which was afforded by this occurrence determined Gen. Halleck to adopt more stringent measures to secure adherence to the Government, and on the 26th he issued the following order:

**HEADQUARTERS, DEPARTMENT OF MISSOURI.**

The President, Secretary, Librarian, Directors, and other officers of the Mercantile Library Association, the President, Secretary, Directors, and other officers of the Chamber or Chambers of Commerce of this city are required to take the oath of allegiance prescribed by article 6 of the State ordinance of October 16, 1861.

Any of the above officers who shall neglect to file in the office of the Provost Marshal General, within ten

days of the date of this order, a copy of the oath so subscribed, will be deemed to have resigned; and any who, after neglecting to file his oath of allegiance within the time prescribed, shall attempt to exercise the functions of such office, will be arrested for contempt of this order, and punished according to the laws of war.

2d. It is officially reported that carriages bearing the enemy's flag are in the habit of driving to the vicinity of the military prison in McDowell's College. The commanding officer of the prison will seize and take possession of any carriage bearing the enemy's flag, and the horses, carriage, and harness be confiscated.

3d. It is officially reported that certain women are in the habit of approaching the vicinity of the military prison, and waving hostile flags, for the purpose of insulting our troops and carrying on communications with the prisoners of war. The commanding officer of the prison guard will arrest and place in confinement all women so offending.

4th. Any carriage or other vehicle bearing a hostile flag in the city will be seized and confiscated. The city police and patrol guards are directed to arrest persons in vehicles under such flags; also, persons wearing or displaying a hostile flag in the city.

By command of Maj.-Gen. HALLECK.  
M. H. McLEAN, Asst. Adj.-Gen.

This measure was followed by the promulgation of an order dated Feb. 8d, requiring the president and faculty of the University of Missouri to take the oath of allegiance under penalty of having their offices vacated. "The institution," observed Gen. Halleck, "having been endowed by the Government of the United States, its funds should not be used to teach treason or to instruct traitors." The order also exacted a similar oath from the presidents and managers of all railroads in the State, together with a bond that they would not employ persons neglecting to conform to the same requirement; directed the commissary and subsistence departments to deal with none but those who had taken the oath, or were men of approved loyalty; and recommended that all clergymen, professors, and teachers, and all officers of public and private institutions for education, benevolence, business, and trade, in favor of the perpetuation of the Union, should voluntarily subscribe to and file the oath of allegiance, in order that they might be distinguished from those wishing to encourage rebellion, and to prevent the Government from restoring peace and prosperity.

A supplementary order required all licensed attorneys, counsellors, and proctors, to take the oath, under penalty of being debarred from practising in the courts; and another, more general in its provisions than any which had preceded, was in the following terms:

It is hereby ordered that at all future elections in this State, whether State, municipal, county, or town elections, every voter will be required to take the oath of allegiance required by the State Convention, Oct. 18, 1861. Officers of polls will see to the execution of this order. If they receive votes of persons not taking the oath, they will be arrested and tried for military offence, and the elections declared null and void.

The arrest and trial of the persons apprehended in northern Missouri for destroying the bridges and other property of the Hannibal and St. Joseph's railroad, led to an important correspondence between Gens. Halleck and

Price, touching the right of the prisoners to be dealt with as ordinary prisoners of war. The extracts which follow sufficiently indicate the points raised by the Confederate general, and the policy of Gen. Halleck.

After complaining of the unusual and cruel confinement to which his discharged soldiers had been subjected, Gen. Price observes :

I have obtained information that individuals and parties of men specially appointed and instructed by me to destroy railroad culverts and bridges, by tearing them up, burning, &c., have been arrested and subjected to general court martial, for alleged crimes, which all laws of warfare, heretofore recognized by the civilized world, have regarded as distinctly proper and lawful. I have learned that such persons, when tried, if convicted of the offence or offences, as stated, are viewed as lawful subjects for capital punishment. These statements I cannot believe to be correct, but let us understand each other on this subject.

Do you intend to continue the arrest of citizens engaged in their ordinary peaceful pursuits and treat them as traitors and rebels? If so, will you make exchange with me for such as I may or will make for similar cases? Do you intend to regard the members of this army as persons deserving death wherever and whenever they may be captured, or will you extend to them the recognized rights of prisoners of war by the code of civilized warfare? Do you regard the destruction of important roads for transportation facilities for military purposes as the legal right of the belligerent power? Do you intend to regard men whom I have especially despatched to destroy roads and burn bridges, tear up culverts, &c., as amenable to the enemy's court martial, or will you have them tried as usual by the proper civil authorities according to the statutes of the States?

To this Gen. Halleck replied :

Where individuals and parties of men violate the laws of war, they will be tried, and, if found guilty, will certainly be punished, whether acting under your special appointment and instructions or not. You must be aware, general, that no orders of yours can save from punishment, spies, marauders, robbers, incendiaries, guerilla bands, etc., who violate the laws of war. You cannot give immunity to crimes. But let us fully understand each other on this point. If you send armed forces, wearing the garb of soldiers, and duly organized and enrolled as legitimate belligerents, to destroy railroad bridges, &c., as a military act, we shall kill, if possible, in open warfare, or if we capture them we will treat them as prisoners of war. But it is well known that you have sent numbers of your adherents in the garb of principal citizens, and under false pretences, through our lines into northern Missouri, to rob and destroy the property of Union men, and burn and destroy railroad bridges, thus endangering the lives of thousands; and this, too, without any military necessity or possible military advantage. Moreover, peaceful citizens of Missouri, quietly working on their farms, have been instigated by your emissaries to take up arms as insurgents, and rob and plunder, and commit arson and murder. They do not even act under the garb of soldiers, but under false pretences, and in the guise of private citizens. You certainly will not pretend that men guilty of such crimes, although specially appointed and instructed by you, are entitled to the rights and immunities of ordinary prisoners of war. If you do, will you refer me to a single authority on the laws of war which recognizes such a claim?

The trial of the bridge burners, meanwhile, went on before a military commission in Palmyra, and in the latter part of January eight persons were found guilty, and sentenced to be shot. In accordance with the views above ex-

pressed, Gen. Halleck approved of the sentence, and ordered it to be carried into effect in the succeeding month. And inasmuch as the secession organizations for the destruction of railroad property in northern Missouri exhibited occasional activity, a bridge near Palmyra, just reconstructed, having been burned as recently as the 25th of January, he directed in a general order, issued February 16, that all persons "accused of acts in violation of the laws of war, such as the destruction of railroads and bridges and private property, firing into trains, assassination, &c., should not be released on any terms, but be held for trial before a military commission."

In the last week of January the national forces, under Gen. Curtis, commenced their march southward, and on the 18th of February the advanced guard entered Springfield, Gen. Price retiring across the boundary into Arkansas at their approach. (*See ARMY OPERATIONS.*) This movement, for the time, freed the State of the presence of armed opponents of the Government, and the St. Louis papers of February 22 announced, with no little satisfaction, that "the last vestige of military insurrection had been swept away." In view of this fact, and of the increasing loyalty of the citizens of Missouri, as well as of the recent victories in Tennessee, Gen. Halleck issued an order abating the stringent military regulations in force in the State, and mitigating the sentence of death against the bridge burners to close confinement in the military prison; but with this proviso, that if Confederate spies should again destroy railroads or telegraph lines, the original sentence should be carried into effect. He also directed that no further assessments should be levied on persons who had taken the prescribed oath of allegiance.

Lieut.-Gov. Hall, in the absence of Governor Gamble, appointed Robert Wilson, president of the State Convention, and John B. Henderson, a Douglas democrat, as United States Senators, in the place of Waldo P. Johnson and Truett Polk, whose seats had been declared vacant by a resolution of the Senate of January 10th.

In the latter part of January the troops destined by Gen. Halleck to cooperate with the army of Gen. Grant in Tennessee, took their departure from Commerce, on the Mississippi river, under Gen. Pope, for New Madrid. (*See ARMY OPERATIONS.*)

The departure of General Halleck for Corinth, in April, left Gen. Schofield in command of the greater part of the State, and on June 1st he assumed command of the entire department of Missouri, fixing his headquarters at St. Louis. On April 8th Gen. Sterling Price resigned the command of the Missouri State guard.

On June 8d, the State Convention met pursuant to adjournment at Jefferson City. In an official communication Gov. Gamble reviewed the history of affairs during the interval succeeding the adjournment of the convention, and showed that the finances of the State were still

in an unsettled condition, only forty-one counties out of one hundred and twelve having returned tax books for 1861. Of \$640,220 due from these not more than \$258,886 had been paid in. From the counties not heard from the amount was very large; but officers were daily finding it more easy to make collections, and in every respect the condition of things was quite as favorable as when the present authorities received control of the government. The bondholders, he thought, could hardly expect the July interest to be paid, but of the ability of the State to pay ultimately he entertained no doubt. In most parts of the State courts of justice were open and the laws properly administered, but elsewhere disturbance and crime were perpetrated under the name of guerilla warfare. Sufficient force, however, was now ready to compel the cessation of such acts, and "troops hostile to the people and the institutions of the State" had been supplanted by home volunteers, who would prove less objectionable. He doubted the expediency of electing members of Congress seventeen months before taking their seats, and, in view of the fact that a large body of the voters of the State were absent as volunteers, suggested the repeal of the ordinance passed in the previous November, which provided for an election of executive officers and for the ratification of the provisional government in August.

On June 4th the Committee on Elections reported bills continuing the present officers of the State until 1864; repealing the ordinance submitting the action of the convention to the people; and defining the qualifications of voters in the State. The last named bill prohibited all Confederates from holding office or voting except on condition of taking the oath to support the constitutions of the United States and Missouri, and required judges of elections to administer a similar oath to all voters.

On the 7th Judge Breckenridge of St. Louis introduced a bill for gradual emancipation, framed in accordance with the President's Message to Congress.

He argued the merits of the bill at length, claiming that it was the only measure at all likely to quiet the agitation rapidly growing in the State. All men agreed that slavery was doomed in Missouri, that secession had ruined it, and it only remained to determine whether, as wise, careful, and conservative men, they would take hold of the subject as a political question, or leave it to be dealt with by radicals. Pass this ordinance, and there would be nothing left to build up radical men and measures; the whole subject could be acted on by the people, after two years of calm reflection, with peace, quiet, and prosperity restored to the country.

At the conclusion of Mr. Breckenridge's remarks several members endeavored to gain the floor, and Mr. Hall, of Randolph county, being recognized, moved to lay the bill on the table. In spite of the remonstrances of several mem-

bers, who wished to speak on the subject, Mr. Hall adhered to his motion, which was carried by yeas 52 to nays 19. He then moved to reconsider the motion to lay on the table, and to lay that motion on the table. This was agreed to, and thus the emancipation scheme was thwarted almost at its inception.

During the 9th and 10th the convention was chiefly occupied in discussing the bill defining the qualifications of voters, which had been reported back without the disfranchising clause. An amendment, offered by Judge Breckenridge, "to disfranchise all persons engaged in rebellion subsequent to Dec. 17, 1861," was, after a protracted debate, carried by a vote of 85 yeas to 81 noes, and the bill was finally passed by 42 yeas to 27 nays. The chief objection urged against the amendment was, that it would discourage emigration from the Southern States.

On the 11th, the bill to continue the present provisional government and postpone the election of State officers until 1864, elicited much discussion, and was finally lost by yeas 31, nays 35. But on the next day the vote was reconsidered by yeas 43, nays 15, and the bill was passed by yeas 45, nays 21. A resolution expressing the confidence of the convention in the integrity and patriotism of Governor Gamble and the other State officers was also unanimously adopted. By this action of the convention the next election was restricted to the choice of members of the 38th Congress and of the State Legislature. On the 12th also an ordinance was passed enabling citizens of the State in the military service of the United States to vote at all the State elections.

On the 13th, Governor Gamble submitted a message calling the attention of the members of the convention to the fact that Congress had, in accordance with a message from the President adopted a joint resolution declaring its willingness to furnish aid to any State that might think proper to adopt a measure of emancipation.

On motion of Judge Breckenridge the message was referred to a special committee of five, consisting of Messrs. Breckenridge, Douglass, Doniphan, Orr, and Howell, with instructions to report without delay upon the subject, by resolution or otherwise. The majority of the committee, Messrs. Breckenridge, Douglass, and Orr, accordingly reported on the 14th the following series of resolutions, by Mr. Hitchcock, of St. Louis, previously referred to the committee, and which were adopted by a vote of 32 to 27:

*Whereas*, The Congress of the United States, on the special recommendation of the President, has adopted a joint resolution in the following words, to wit:

*Resolved*, That the United States ought to cooperate with any State which may adopt a gradual emancipation of slavery, giving to such State at its discretion compensation for the inconvenience, public and private, by such a change of system.

*And whereas*, the President of the United States, in his recent proclamation revoking and annulling a certain authorized declaration, assumed to be made by Maj.-Gen. Hunter, of the United States army, has

earnestly invited the people of the States interested to take into consideration the said joint resolution; be it therefore

*Resolved 1st.* That in the opinion of this convention the proposition contained in the said joint resolution adopted by Congress, approved, 1862, is entitled as well from its source as from its intrinsic importance to the deliberate and respectful consideration of the people of Missouri.

*Resolved 2d.* That while a majority of the convention have not felt authorized at this time to take action in respect to the grave and delicate question of private rights and public policy, presented by said resolution, yet this body desires cordially to recognize as well the generous spirit displayed by the Government of the United States as the eminent patriotism and ability which have distinguished the President of the United States in his efforts to subdue this unholy rebellion, and restore peace and order to this State.

An ordinance was then adopted fixing the time for all subsequent general elections on the Tuesday next after the first Monday in November, and the convention adjourned to the 4th of July, 1868, unless sooner called together by the governor.

On June 16th, in pursuance of a call issued some time previous, a mass convention of emancipationists, consisting of 195 delegates from 25 counties, assembled at Jefferson City, to organize the party for the fall elections. The following, among other resolutions, were unanimously adopted by the convention, a considerable number, if not a majority, of whom were slaveholders:

*Resolved,* That the President of the United States, by and with the approval of the National Congress, having invited the loyal slave States to a consideration of the propriety of initiating a system of gradual emancipation for the purpose of relieving themselves from the incubus of slavery, and removing causes that are seized upon to promote disloyalty; and, furthermore, our own State Convention having had that subject before them for action and thought, and having, after mature reflection, resolved it was, in view of present exigencies, one worthy of "the deliberate and respectful consideration of the people of the State of Missouri," therefore we take this the earliest opportunity of bringing the subject matter involved before our citizens for their consideration, in order that they may take such action in regard thereto, both as they have been invited to take, and as the public necessities require they should take in the premises.

*Resolved,* That we are in favor of initiating forthwith a system of emancipation for the State of Missouri, gradual in its character, and the operation of which shall be so adjusted as not to work injury to the pecuniary interests of any loyal citizens whose vested property rights may be involved, and not to disturb by any violent disruption present social relations in our community.

*Resolved,* That the General Government, by the munificent tender of aid to the State, has relieved the question of emancipation in Missouri of all constitutional and financial embarrassment.

*Resolved,* That it should be the duty of the next General Assembly of this State to take measures for securing from the National Government the aid pledged by resolution of Congress to those States undertaking the establishment of a system of gradual emancipation, and that the same should be so disposed of as to insure compensation to such as may be adjudged as entitled to compensation for any losses that may be sustained in the inauguration and consummation of such a policy.

Scarcely had the two conventions dissolved when the State was threatened by a new and

formidable outbreak of guerillas, who were emboldened by the absence of the greater part of the national forces to repeat on a more extensive scale their operations of the previous year. The greater part of them consisted of the disbanded troops of Gen. Price.

On June 22, Gen. Schofield issued an order holding "rebels and rebel sympathizers responsible in their property, and, if need be, in their persons, for damages thereafter committed by guerillas or marauding parties."

This had so little effect that by the middle of July the whole northern and western parts of the State were disturbed by rumors of guerilla raids and outrages. In the northeast quarter Col. Porter and Col. Quantrell began, as early as the last week in June, to gather followers about them, and early in July the former was defeated and his band dispersed, at Cherry Grove, in Schuyler county, on the Iowa line.

The increasing alarm in the State, heightened by the apprehension that the sudden rising of the guerillas was to be followed by another invasion from the South, rendered necessary vigorous measures of defence, and on July 22 the following important order was issued by Governor Gamble:

HEADQUARTERS, STATE OF MISSOURI, }  
ADJUTANT-GENERAL'S OFFICE, ST. LOUIS, July 22, 1862. }

The existence of numerous bands of guerillas in different parts of the State, who are engaged in robbing and murdering peaceable citizens, for no other cause than that such citizens are loyal to the Government under which they have always lived, renders it necessary that the most stringent measures be adopted to punish all such crimes, and to destroy such bands.

Brigadier-General John M. Schofield, in command of the Missouri State militia, is hereby authorized to organize the entire militia of the State into companies, regiments, and brigades, and to order into active service such portions of the force thus organized, as he may judge necessary for the purpose of putting down all marauders, and defending peaceable citizens of the State.

H. R. GAMBLE,  
Governor of the State of Missouri.

This was followed on the same day by an order from Gen. Schofield for the immediate organization of all the militia of Missouri for the purpose of exterminating the guerillas infesting the State.

The organization of the militia was effected with energy and rapidity, and in a brief space of time the forces of the State were prepared to make vigorous opposition to the guerillas in all quarters.

On July 28, Cols. Porter and Cobb were defeated in Callaway county, on the Missouri river; but within three days the former captured Newark, in Knox county, with two companies of national troops. About the same time a new partisan leader, Col. Poindexter, began to be active in the central counties on the Missouri, and during the first week in August his movements, together with those of Col. Quantrell in the west, compelled the national commanders to take additional measures of precaution. On August 6th, Col. Porter



was disastrously defeated by Col. McNeil, at Kirksville, in Adair county, and for several weeks was compelled to keep aloof from active operations. As a consequence, the war shifted to central and western Missouri, where Cols. Coffee and McBride were reported to have come to the assistance of Col. Quantrell.

After a series of desultory skirmishes, an attack was made on the 13th by the combined bands of these leaders, who had been joined a short time previous by Col. Hughes, and other officers of the Confederate army, upon Independence, resulting in a severe defeat of the State troops; and two days later a body of 800 of the latter were drawn into an ambuscade at Lone Jack, Jackson county, by Cols. Quantrell and Coffee, losing two pieces of cannon, and a number of prisoners. Heavy reinforcements under Gen. Blunt, of Kansas, coming up, however, the guerillas beat a hasty retreat southward, and never paused until they were over the Arkansas line.

Scarcely was the southwest cleared of guerillas than their operations commenced in the north with renewed activity. Col. Poindexter, after several defeats, was captured early in September, but so daring were the raids of Col. Porter and his followers in Lewis, Maria, and other northeastern counties, that a Palmyra newspaper declared the whole of that part of the State "to be in the possession of the rebels, with the exception of the posts immediately garrisoned by State or United States troops." It estimated the number of the Confederates at 5,000, divided into numerous small bands, and commanded by reckless and enterprising leaders. On the 12th, Palmyra, occupied by a small Union garrison, was plundered by Col. Porter's force; but, subsequent to the 15th, the efforts of Cols. McNeil, Guitar, and other Union commanders began to discourage the guerillas, whose strength was gradually frittered away in petty combats.

By an order from the War Department of September 19, the States of Missouri, Kansas, and Arkansas were formed into a military district, under the command of Gen. Curtis, and soon after Gen. Schofield assumed command of the so-called "Army of the Frontier" in southern Missouri. Moving with rapidity and in considerable force, he broke up a formidable camp in Newtonia, and by the 10th of October had driven the enemy completely over the Arkansas border. In the latter part of the same month Cols. Lazear and Dewey defeated the Confederate bands in southeastern Missouri in several engagements, capturing many prisoners, and driving them finally into Arkansas. Col. Quantrell had reappeared in the west in the middle of September, but was almost uniformly beaten in his encounters with the State troops, and by the end of October the war, both there and in the north, was practically ended.

Before this event was consummated in the north an incident occurred in Palmyra, which

created no little comment throughout the State. On the occasion of Col. Porter's raid upon Palmyra, in September, he had captured, among other persons, an old and respected resident of the place, by name Andrew Allsman, who had formerly belonged to a cavalry regiment, and had been, from his knowledge of the surrounding country, of great service to scouting parties sent out to arrest disloyal persons. Allsman was not paroled like ordinary prisoners, but was conveyed by the band to one of their hiding places, and from the known hatred of his captors and their repeated threats, it was believed that he would be summarily executed by them. When several weeks had elapsed without intelligence of him, this belief ripened in the minds of his friends into absolute conviction, particularly as several Union men had been barbarously murdered by the guerillas in the course of the campaign.

When Gen. McNeil returned to Palmyra, and ascertained the circumstances under which Allsman had been abducted, he caused to be issued, after due deliberation, the following notice:

PALMYRA (Mo.), October 8, 1862.

JOSEPH C. PORTER.—SIR: Andrew Allsman, an aged citizen of Palmyra, and a non-combatant, having been carried from his home by a band of persons unlawfully arrayed against the peace and good order of the State of Missouri, and which band was under your control, this is to notify you that unless said Andrew Allsman is returned unharmed to his family within ten days from date, ten men who have belonged to your band, and unlawfully sworn by you to carry arms against the Government of the United States, and who are now in custody, will be shot, as a meet reward for their crimes, amongst which is the illegal restraining of said Allsman of his liberty, and, if not returned, presumptively aiding in his murder. Your prompt attention to this will save much suffering.

Yours, &c.

W. R. STRACHAN.

Provost Marshal General,  
District N. E. Missouri. Per order of Brigadier-Gen.  
Commanding McNeil's column.

A written duplicate of this notice he caused to be placed in the hands of the wife of Joseph C. Porter, at her residence in Lewis county, it being well known that she was in frequent communication with her husband. The notice was published widely, and as Porter was in northeast Missouri during the whole of the ten days subsequent to the date of this notice, it is supposed to be impossible that he should have been unaware of Gen. McNeil's determination in the premises.

The ten days having elapsed without tidings of Allsman, ten prisoners, already in custody, were selected to pay with their lives the penalty demanded.

They received the announcement for the most part with composure or indifference, and were executed at Palmyra, on October 18, in the presence of a multitude of spectators, in literal accordance with the notice of Gen. McNeil.

The act excited the animadversions of many friends of the Union cause, and gave occasion

to a vindictive retaliatory order from President Davis. (*See PRISONERS, EXCHANGE OF.*)

Early in October the political parties began to prepare for the November election, and the issue of emancipation or anti-emancipation was at once distinctly set before the people of the State. The emancipationists, however, were divided in sentiment on several important points, the radical portion, under the lead of B. Gratz Brown, of the "Missouri Democrat," being in favor of immediate emancipation, while the more conservative members of the party, represented by Col. Frank P. Blair, urged a gradual removal of slavery from the State. Many of the latter were slaveholders and residents of large slaveholding districts, and, although pledged unconditionally to the maintenance of the Union, were necessarily averse to the too sudden dissolution of the relations of master and servant. Throughout the State generally the two divisions of the party united in the support of the same candidates; but in St. Louis a somewhat bitter contest was waged between them, which, had not the democrats been in a very small minority, might have led to the defeat of the emancipation ticket in that city.

On Tuesday, Nov. 4, the election took place, and resulted in the choice of the following members of Congress: 1st district, F. P. Blair; 2d do., H. T. Blow; 3d do., John W. Noell; 4th do., S. H. Boyd; 5th do., J. W. McClurg; 6th do., Austin A. King; 7th do., Benjamin Loan; 8th do., W. A. Hall; 9th do., James S. Rollins. Of these Blair, Blow, Noell, Boyd, McClurg, and Loan were avowed emancipationists, King and Hall democrats, and Rollins a Union man. In St. Louis, the contest between Blair and Knox, the radical emancipation candidate, was very close, the official return showing a vote of 4,743 for Blair to 4,590 for Knox, and 2,536 for Bogy, democrat. The emancipationists were equally successful in securing a majority in both branches of the Legislature, that in the lower house being large.

On December 29, the new Legislature met at Jefferson City, and the House of Representatives was immediately organized by the election of the emancipation candidate for Speaker, by a vote of 67 to 42. On the succeeding day Governor Gamble submitted his annual message.

After congratulating the Legislature and the State upon the fact that a Union General Assembly had at length been convened, he reviewed the condition of the State since the outbreak of secession, and showed that the number of volunteers from Missouri, after allowing for the casualties of war, and mustering out irregularly enlisted troops, was 27,500, which, with 10,500 State militia, gave a total force of 38,000 men in service for the war. The enrolled militia, numbering 52,000, would give the State the grand total of 90,000, the latter force furnishing a large body of men, armed and equipped for any emergency.

The indebtedness of the State, according to report of the auditor, was stated at \$27,370,090, composed of the following items:

Miscellaneous debt.....	\$602,000
Pacific Railroad bonds (main).....	7,000,000
Pacific Railroad, Southwest branch.....	4,500,000
Hannibal and St. Joseph.....	3,000,000
North Missouri.....	3,850,000
Iron Mountain.....	3,600,000
Calro and Fulton.....	650,000
Platte county.....	700,000
Revenue bonds.....	481,000
State defence warrants.....	725,000
Arrears of interest due.....	1,813,090
	\$27,370,090

In view of the constantly increasing arrearages of interest upon this sum, owing to the impossibility of collecting the State taxes during the continuance of the civil war, he earnestly recommended the adoption of measures to restore the State credit and reduce the State debt.

On the subject of emancipation he observed that he had long been convinced that the material interests of Missouri would be advanced by substituting free for slave labor, and recommended a plan by which the children of slaves born after the passage of the act shall be free, but remain under the control of their owners until they have arrived at a certain age, the owners to be compensated for the diminished value of slave mothers after being thus rendered incapable of bearing slave children. He, however, denied that the Legislature could constitutionally adopt a scheme by which the owners of slaves could be divided into classes, and the slaves of one class be emancipated without compensation while compensation was provided for the other class.

MITCHEL, ORMSBY MACKNIGHT, an American astronomer, and major-general of volunteers in the United States service, born in Union co., Ky., Aug. 28, 1810, died of yellow fever, at Beaufort, S. C., Oct. 30, 1862. He received his early education at Lebanon, Warren co., Ohio, and, at 12 years of age, began life for himself as clerk in a store in Miami, Ohio. In 1825 he received an appointment to a cadetship in West Point. In 1829 he graduated fifteenth in a class of 46, among which were Robert E. Lee and Joseph E. Johnston, now generals in the Confederate service. He was at once appointed assistant professor of mathematics, which position he occupied for two years. He subsequently studied law, was admitted to the bar, and practised in Cincinnati until 1834, when he was elected professor of mathematics, philosophy, and astronomy in the Cincinnati College. In 1845 he proposed the establishment of an observatory at Cincinnati, raising nearly the whole of the requisite amount by his own exertions, and was made director of the institution. To obtain the necessary apparatus he took a flying trip to Europe, visited London, Paris, and Munich, completed his contracts and returned to his college duties in the short space of 14 weeks. In 1859 he was chosen director of the Dudley Observatory at

Albany, retaining, at the same time, his connection with that at Cincinnati. As an astronomical lecturer, he was exceedingly popular, and among the monuments of his skill in perfecting the necessary apparatus for that department of science is an instrument at Albany for recording right ascensions and declinations by electro-magnetic aid to within  $\frac{1}{1000}$  of a second of time, and for the measurement, with great accuracy, of large differences of declination incapable of being reached by the micrometer.

Among his published works are: "Planetary and Stellar Worlds," "Popular Astronomy," and a treatise on Algebra. On the 1st of July, 1846, he commenced the publication of a periodical entitled the "Sidereal Messenger," which, at the end of two years, was discontinued for want of sufficient patronage. At the breaking

out of the present war, Professor Mitchel left his scientific pursuits and sought an opportunity of serving his country. In August, 1861, he was commissioned brigadier-general of volunteers, and ordered to the department of the Ohio, under the command of Maj.-Gen. Buell. After the capture of Bowling Green and Nashville he made a forced march southward and seized the railway between Corinth and Chattanooga, thereby breaking the enemy's line of communication, and possessed himself of various points in northern Alabama, for which he was made a major-general. In July, 1862, he was relieved of his command, and, on the 17th of the September following, was appointed commander of the department of the South, where he was making preparations for a vigorous campaign when he fell a victim to the yellow fever.

## N

NASHVILLE. Intelligence of the capture of Fort Donelson reached Nashville on Sunday, February 16, and produced the utmost consternation. The Confederate governor, Harris, immediately convened the Legislature, but they speedily adjourned to Memphis, whither the public archives and money were also removed. On the same day, Gen. A. S. Johnston passed through the city on his retreat from Bowling Green, and, before nightfall, hundreds of families were abandoning their homes and making their way southward. The general confusion was increased by the destruction of unfinished steamers at the wharves, and the free distribution of the stores by the military authorities to all who would take them. On Monday the public stores were closed, and an effort was made by Gen. Floyd, who had been placed in command of the city, to recover what had already been given out; but on Tuesday the distribution began again, and continued until Saturday morning. On Tuesday night the troops destroyed the wire bridge and railroad bridge across the Cumberland river, in spite of the earnest remonstrances of the leading citizens. The former cost \$150,000, and the latter \$250,000. Governor Harris made a speech recommending the citizens to burn their private property, and calling on Tennesseans to rally and meet him at Memphis, but little or no response was made to his appeal. The machinery was removed from many of the most important workshops and carried to Chattanooga. On the 23d, the rear guard of the Confederates evacuated the city, and the same day the advance of Gen. Buell's column occupied Edgefield, a small town on the opposite side of the river. The next day Mayor Cheatham and a committee from Nashville waited upon the general, and agreed to surrender the city at a certain hour on the following morning (the 25th), receiving

assurances that the liberty and property of all citizens should be sacredly respected. Before the surrender was effected, however, Gen. Nelson arrived with his column on transports, accompanied by the gunboat St. Louis, and landed at Nashville. The following proclamation was afterward issued by the mayor:

The committee representing the city authorities and people have discharged their duty by calling on Gen. Buell, at his headquarters, in Edgefield, on yesterday. The interview was satisfactory to the committee, and there is every assurance of safety and protection to the people, both in their persons and property. I therefore respectfully request that business be resumed, and that all our citizens of every trade and profession pursue their regular vocations. The county elections will take place on the regular day, and all civil business will be conducted as heretofore. Commanding General Buell assures me that I can rely upon his aid in enforcing our police regulations. One branch of business is entirely prohibited, viz., the sale or giving away of intoxicating liquors. I shall not hesitate to invoke the aid of Gen. Buell in case the recent laws upon the subject are violated. I most earnestly call upon the people of the surrounding country, who are inside the Federal lines, to resume their commerce with the city, and bring in their market supplies, especially wood, butter, and eggs, assuring them that they will be fully protected and amply remunerated.

R. B. CHEATHAM, Mayor.

The city remained perfectly quiet, and the Federal troops, to use the words of the Confederate press, "conducted themselves with marked propriety." The Union feeling in the city, however, was for many weeks extremely faint. A correspondent, writing ten days after Gen. Buell's arrival, says: "The disagreeable, but irresistible conviction forces itself upon the mind of even a superficial observer, that whatever the number and warmness of Unionists may have been at the time when, and for some time after Tennessee was juggled out of the Union, eight out of every ten have been made submissionists by the protracted secession pres-

sure that was brought to bear upon them." The same writer adds: "Most of the stores continue closed. But few male and fewer female inhabitants are visible upon the streets. Victorious soldiery alone enliven them. Half of the private residences are deserted, and add further gloom to the aspect by their closed doors and window shutters and grave-like stillness. Hardly less than a third of the population must yet be absent."

Senator Andrew Johnson, military governor of Tennessee, by appointment of President Lincoln, Horace Maynard, M. C., Emerson Etheridge, and other prominent Union exiles, arrived at Nashville on March 12, and the next evening delivered speeches, which were listened to with considerable favor by a large audience.

The newspapers of Nashville had all suspended publication on the evacuation of the city by the Confederates, but they soon reappeared, and one of Governor Johnson's first official acts was to place them under military supervision. The "Daily Times," in consequence of this measure, was discontinued. On the 10th of April, a daily paper was started, under the title of the "Daily Nashville Union."

On the 25th of March, Governor Johnson requested the municipal officers to take the oath of allegiance. The city council refused, by a vote of 16 to 1, and the following reply was accordingly sent to the governor:

CITY HALL, NASHVILLE, March 27, 1862.

Gen. Andrew Johnson, Military Governor of the State of Tennessee:

Sir: Your communication of the 25th inst., requiring the mayor, members of the city council, police, and other city officials, to take an oath to support the Constitution of the United States, pursuant to the first section of the tenth article of the Constitution of the State of Tennessee, has been received and duly considered.

We respectfully beg leave to submit the following facts for your Excellency's consideration:

Since we have had any connection with the city Government, which, in some cases, has been for several years, we have never before been required to take any other oath than the simple oath of office, to discharge our respective duties faithfully; and upon a reference to the records of the city, running back for twenty-five or thirty years, we find that no former mayor nor aldermen have taken any oath to support either the Constitution of the State of Tennessee or the United States; but the understanding seems to have been that the provision of the Constitution referred to applied only to State and county, and not to corporation officers.

We have also consulted some of our best lawyers upon the subject, and the majority of them are of opinion that we, as municipal officers, do not come within the purview and meaning of said section of the Constitution, but that the same applies alone to State and county officials.

Under the foregoing facts and circumstances, and we having taken the only oath ever taken by, or required of, our predecessors, and never having been required to take any oath inimical to our allegiance to the United States or the State Government, we respectfully ask to be excused from taking the oath sent us, honestly believing that, under the Constitution and our charter, we are not properly subject to such requirement, and believing that the same was made of us under a misapprehension of what had been required heretofore.

On the 29th the mayor and several other citizens were arrested for treason, and a few days later Governor Johnson issued a proclamation ejecting from office the mayor and most of the city councilmen, and appointing other persons to fill their places. Numerous arrests were made for disunion practices about the same time.

On April 24 the following resolutions were adopted by the city council:

*Resolved*, That the Mayor of the city of Nashville is requested and instructed to have the flag of the United States placed upon all public property belonging to the Corporation.

*Resolved*, That the Board of Education are hereby requested, during the present week, to take the oath of office taken by ourselves and other officers of the city.

*Resolved*, That the Superintendent, together with every teacher in each of the public schools of the city of Nashville, shall be and they are hereby requested to take the oath of allegiance prescribed to us within five days from the passage of this resolution, or resign their respective positions.

The last resolution was lost in the board of Aldermen. The condition of the city on the 1st of May is thus described by the "Union":

"Our courts are proceeding pretty much as formerly. The United States court is in session, and the regular business pursuing its accustomed channels. Process is being issued daily from the circuit and chancery courts, returnable to their next terms. The magistrates' courts are also in continuous session. Business is beginning to recover and to wear its accustomed appearance, and as facilities are being opened with the country, it is extending in all directions. Our city market is daily improving. Prices are rapidly moderating to a reasonable standard, and custom proportionately increasing. The passenger and freight trains on the Louisville and Nashville railroad are making daily trips. The cars on the Tennessee and Alabama road run as far as Columbia; those on the Nashville and Chattanooga road run as far as Wartrace, and connect by branch road with Shelbyville. Houses left vacant, some time since, are now nearly all occupied, and the inquiry for houses to rent is becoming active. This is the case with both dwelling and business houses. Some sales in real estate are being effected at reasonably good prices. Confidence in our State currency is being restored, and there is a corresponding appreciation in the value of our bank notes."

A great Union meeting was held at Nashville on the 12th. (*See TENNESSEE.*)

On the 24th several Confederate newspaper offices and other establishments were seized by the United States marshal, in accordance with the general confiscation act passed by Congress.

On the 29th General Dumont, commanding the Federal forces at Nashville, issued the following order respecting trade with the interior:

*General Order No. 7.*

Whereas, it is represented to me that salt, bacon, coffee, iron, leather, medicines, and other goods, are being sold in this city and finally find their way to the enemy:

It is ordered that no goods shall be sold in, or taken away from, this town or vicinity, toward the enemy's lines, without a written permit from the Provost Marshal of the city, which permit shall specify and contain an accurate list of the articles that may be bought, sold, and shipped; but this prohibition shall not apply to necessary articles, not contraband, in small quantities absolutely necessary for family use, sold to citizens of the town or neighborhood, the person selling and buying and transporting being held to a rigid accountability that no improper use is made of the same.

Any person violating this order, or in any way aiding or consenting to its violation, will be held as an enemy and punished accordingly.

All guards and officers are charged with the arrest of any and all persons violating this order, and will examine wagons and other vehicles of transportation, to see that it is enforced.

On June 8 an order was published entirely forbidding the retailing of intoxicating liquors.

On July 18 the Nashville "Union" published the names of some 700 persons, a portion of those who had voluntarily taken the oath of allegiance before the provost marshal in that city.

The ravages of the guerrillas in the vicinity of Nashville caused great alarm, and it was believed that they were about marching upon the city, which at this time was but ill prepared for a defence. At the suggestion of a few private persons the military band of the 69th Ohio marched through the streets on the 14th, and word being given that the loyal citizens would hold a meeting for the purpose of organizing a force for home defence, in a short time a large procession gathered and proceeded to the capitol. Here they were addressed by the governor, the mayor, and other persons, and the governor, in the course of his speech, made the following offer: "All loyal men who will take the obligation, will be furnished with arms and ammunition. If the volunteers serve as much as a month, they shall be paid for their time, and if absent from home shall receive rations."

A large force was very soon recruited, and reinforcements arrived also from the army, so that the panic died out. Toward the end of the month the guerrillas succeeded for a time in completely cutting off communications by railroad and telegraph between Nashville and the North. Some of the streets of the city were barricaded on the night of July 21, in anticipation of the approach of Col. Forrest, and the work of fortifying the city was pushed forward with the greatest possible rapidity. One thousand negroes, belonging to Confederate slaveowners of the county, were impressed by Col. Miller, commanding the post, to labor on the fortifications. Their masters were required to provide them with tools and subsistence, and the length of service and terms of payment were to be fixed by the Government. About the middle of August railroad communication with Nashville was again cut off; prices of nearly all the necessaries of life rose to an unprecedented height, and apprehensions were felt of a scarcity of provisions. The demolished tracks and bridges were replaced as speedily

as possible, but intercourse continued extremely precarious and irregular.

The following circular was addressed by Gov. Johnson to a number of the richest secessionists of Nashville, especially to those who had distinguished themselves by their hostility to the Federal Government or their active friendship for the rebel authorities:

STATE OF TENNESSEE, EXECUTIVE DEPARTMENT, }  
NASHVILLE, August 18, 1862. }

SIR: There are many wives and helpless children in the city of Nashville, and county of Davidson, who have been reduced to poverty and wretchedness in consequence of their husbands and fathers having been forced into the armies of this unholy and nefarious rebellion. Their necessities have become so manifest, and their demands for the necessaries of life so urgent, that the laws of justice and humanity would be violated unless something was done to relieve their suffering and destitute condition.

You are therefore requested to contribute the sum of \_\_\_\_\_ dollars, which you will pay over within the next five days to James Whitworth, Esq., Judge of the County Court, to be by him distributed among these destitute families in such manner as may be prescribed.

Respectfully, &c.,

ANDREW JOHNSON, Military Governor.

Attest:

EDWARD H. EAST, Secretary of State.

The sums thus assessed ranged from \$50 to \$300.

Gen. Rousseau took command at Nashville about the 28th of August, by which date the capital was again, for the fourth time since its occupation by the Union forces, completely isolated from the North. Gen. Rousseau was succeeded a week or two later by Maj.-Gen. Thomas, and he shortly afterward by Gen. Negley. In view of a threatened attack upon the city by Gen. Bragg, police and military regulations were made more stringent. On the 9th of Sept. an order was issued by the provost marshal forbidding the "sale of intoxicating liquors (spirituous, malt, or vinous), wholesale or retail, publicly or privately," in the city of Nashville and vicinity; and on the 10th the following order was published by command of Gen. Thomas:

Hereafter any citizen found in the streets of Nashville between the hours of 9 P. M. and reveille (daylight) without a written pass, will be arrested and confined. Passes to be out after 9 o'clock P. M. will only be granted at the headquarters of the Major-General Commanding.

The Confederate generals J. R. Anderson and Forrest, with the Confederate governor, Harris, concentrated a large force with the avowed purpose of assaulting Nashville; but on Oct. 7 were completely routed at Lavergne, 15 m. from the city by a detachment of Gen. Negley's forces under command of Gen. Palmer. Soon afterward a force of 8,000 or 10,000 Confederates appeared before Nashville and opened a cannonade from a hastily constructed battery, but they were driven off with little difficulty, the movement having been probably a feint to cover other operations. At the same time Col. Morgan's guerillas attempted to destroy the railroad bridge at Nashville (which had been re-

built), but were repulsed with some loss. The army and citizens were now subsisting almost entirely upon supplies obtained by foraging in the neighborhood; and as the Confederates not only restricted to a few miles the area within which Gen. Negley's forage parties could safely operate, but also ravaged the country themselves almost to the outskirts of the city, provisions soon became distressingly scarce. When the advance of Gen. Rosecrans's army reached Nashville, early in November, reopening communication with the North, the troops had been for some time on half rations. From this period until the close of the year the city was the headquarters of Gen. Rosecrans.

About the 20th of November the board of trade appointed in the spring to grant recommendations to loyal persons wishing to ship goods to Nashville resumed operations, and permits to a limited extent were given to traders friendly to the Government.

On the 9th, in order to prevent misunderstandings between citizens and soldiers, Gen. Rosecrans issued an order reminding the troops that loyal men were entitled to all the rights, privileges and protection due to any citizen; that peaceable inhabitants, whether loyal or not, were entitled to immunity from violence and plunder, subject only to needful surveillance; and that outspoken rebels could claim no other protection than that afforded by the laws of war and humanity. Citizens guilty of any acts of hostility, or belonging to partisan corps, being removed beyond the reach of proper military control, were to be treated as pirates and robbers. Soldiers were strictly forbidden to enter private grounds or houses without written permission or order from a commissioned officer, who was to be held responsible for all that was done. Another order, addressed to provost marshals and their deputies, gave special instructions for avoiding unjust and unnecessary arrests of private persons. General Orders No. 23, after prescribing regulations for sutlers, designed to prevent goods from being passed South through the lines of the army, announced that "in towns and cities now or hereafter within the lines of this army, no one will be allowed to sell goods needed for the use of the resident citizens, unless he be a resident trader."

On Dec. 13 Governor Johnson published a proclamation, nearly identical in terms with his circular letter of August 18, calling attention to the destitute condition of the widows, wives, and children of Confederate soldiers, and ordering an assessment of some \$60,000 for their benefit, "from those who contributed directly or indirectly to bring about this unfortunate state of affairs." The population of Nashville in 1860 was 16,988.

NAVY, CONFEDERATE. The passage of secession ordinances by the several States united under the title of Confederate States, was immediately followed by the resignation of nearly all the officers of the United States Navy, who

were residents of any one of those States. These resignations were made with the intention of seeking service under the new Government about to be organized. Their applications met with a ready response from the Confederate Government. A Navy Department was at once organized, and these officers were appointed with a rank similar to that which they had previously held. The grades of rank were afterward altered as follows: admiral, flag-officer, captains, commanders, lieutenant-commanding, first and second lieutenants, lieutenants for the war, masters, passed midshipmen, midshipmen, &c. The officers were assigned to the ports of the Confederate States to perform such duties as might offer in connection with the small steamboats at those places. The operations at sea, under the authority of the Confederate Government, are hereto annexed.

The operations of the Confederate privateer *Sumter* were closed in the year 1861 by the refuge of the vessel in Gibraltar, where, being unable to procure coal, she remained watched by the Federal ship *Tuscarora*. The *Sumter* was finally sold, and the Federal steamer left Gibraltar, Jan. 18th, for the Spanish waters of Algeiras. The efforts of the Confederates were then turned to the formation of an extensive navy by purchasing vessels in England. It very soon became apparent that a number were in process of construction at the shipyards near Liverpool, and the attention of the British Government was called to the fact, which became the basis of diplomatic correspondence. Early in April, the American minister, Mr. Adams, addressed Earl Russell relative to the *Oreto*, then in a forward state, and by general report destined for the Confederate service. For particulars respecting her construction and departure from England, see DIPLOMATIC CORRESPONDENCE. On her arrival at Nassau, she was immediately seized by the captain of her Majesty's steamer *Greyhound*, but almost as quickly released. Shortly after she was seized again, but, after some difficulty, released again. The authorities appeared to have great doubts as to whether she was or was not intended for the Confederate service. On one occasion, when the British gunboat *Bulldog* went to seize her, she was discharging shell. The *Oreto*, on the 4th of September, suddenly appeared off Mobile harbor, which was blockaded by a steamer under Commander George Henry Preble, whose instructions were emphatic against giving offence to foreign nations while enforcing the blockade. The *Oreto* approached flying the English flag and pennants. Commander Preble hesitated to fire lest the stranger should really prove an English man-of-war. The few moments' time lost in the hesitation sufficed for the *Oreto* to pass out of range and gain her object, getting safely into Mobile bay with her freight. For this want of success, Commander Preble was summarily dismissed from the service without a hearing.

On the 27th of December, the *Oreto* again left Mobile bay, fully armed for a cruise, under the command of John Newland Maffit, who was born in Ireland, and when quite young was brought to this country by his father, a celebrated preacher of the same name; was appointed to the United States navy from the State of New York. He originally entered the naval service in the year 1832, and became a citizen of Georgia.

After the sale of the *Sumter* her captain, Semmes, was active in England in building a new vessel, and it was soon ascertained that one was in a forward state for the Confederate service. Complaint was made to the British Government of infringement of the neutrality laws, and means were taken to prevent the departure of the vessel as she approached completion. The orders came, however, too late. Meantime a barque had loaded in London with arms, and sailed from the Thames. The United States ship *Tuscarora* was at the same time watching for the *Alabama* to make her appearance, but she avoided her by taking the North Channel out. After a short run she arrived at the Western Islands, giving an excuse to the authorities for making harbor there. Soon after the barque arrived, alleging stress of weather. The *Alabama* at once hauled alongside of the barque, and cranes were rigged by the order of the *Alabama's* captain. When in readiness he began to transfer the cargo, and this infringement of quarantine rules excited the ire of the Portuguese authorities, but it was alleged that the bark was sinking and it was necessary to save the cargo. On the following day, when the transfer was nearly completed, the British screw steamer *Bahama* arrived, bringing Capt. Semmes and other late officers of the *Sumter*, the remainder of the armament, and 20 more of the crew. This arrival exhausted the patience of the authorities, and all three vessels were ordered to leave at once. The *Bahama* handed over to the *Alabama* what was destined for her and left immediately, followed by the "290" towing the bark. They went a few leagues to Angra bay and remained 24 hours, when they were again ordered to leave, which they did, all being now in readiness. The bark left for Cardiff to load coal for the *Alabama*. Capt. Semmes then took command, mustered the crew, read his commission as post captain in the Confederate navy. It was a document duly attested at Richmond, and bore the signature of "Jefferson Davis, President, Confederate States of America." He then opened and read his sealed orders from the President, directing him to assume command of the Confederate sloop-of-war *Alabama*, hitherto known as the 290, in which (having been duly commissioned) he was to hoist the Confederate ensign and pennant, and "sink, burn, and destroy everything which flew the ensign of the so-called United States of America." Captain Semmes then ordered the first lieutenant to fire a gun, and run up the Con-

federate flag and pennant. The gun was fired by the second lieutenant (Armstrong, a relation of the famous inventor), and ere its smoke had cleared away, the stars and bars of the Confederacy were floating on the breeze, and the ceremony was complete; Captain Semmes declared the vessel, henceforth to be known as the *Alabama*, to have been duly commissioned. The next step was formally to engage the crew to serve and fight under the Southern flag, which having been done, the men were addressed by their captain, who informed them that if any of the crew were dissatisfied they could leave in the *Bahama* about to take her departure for England. The offer was declined, the two vessels parted company, the *Bahama* for England and the *Alabama* in chase of a whaler. The operations of the vessel were very active. The following is a list of vessels captured and destroyed by her:

Sept. 6	Ship <i>Ocmulgee</i> .....	Edgartown,	Burned.
" 7	Schooner <i>Starlight</i> .....	Boston,	"
" 9	Bark <i>Alert</i> .....	"	"
" 9	Schooner <i>Weather Gauge</i> .....	Provincetown,	"
" 9	Bark <i>Ocean Rover</i> .....	Mattapolett,	"
" 18	Ship <i>Benjamin Tucker</i> .....	New Bedford,	"
	Bark <i>Osoola</i> .....	"	"
	Bark <i>Virginia, Tilton</i> .....	"	"
	Ship <i>Ellaha Dunbar, Gifford</i> .....	"	"
	Brig <i>Allamaha</i> .....	Sippican,	"
	Schooner <i>Courser</i> .....	Provincetown,	"
Oct. 8	Ship <i>Brilliant, Hagar</i> .....	New York,	"
" 8	Ship <i>Emily Farnham, Simms</i> .....	"	Released.
" 10	Ship <i>Tonawanda</i> .....	Philadelphia,	Bonded.
" 15	Ship <i>Lamplighter</i> .....	New York,	Burned.
" 15	Ship <i>Manchester</i> .....	"	"
" 15	Brig <i>Dunkirk</i> .....	"	"
" 23	Ship <i>Lafayette, Small</i> .....	"	"
" 23	Schooner <i>Ocean Cruiser</i> .....	"	"
" 26	Schooner <i>Cronshaw</i> .....	"	"
" 28	Bark <i>Laurietta, Wells</i> .....	Boston,	"
" 29	Brig <i>Baron de Castine, Saunders</i> .....	"	Bonded.
Nov. 2	Schooner <i>Allee</i> .....	"	"
" 8	Ship <i>I. B. Wales</i> .....	Boston,	Burned.
" 18	Steamer <i>Ariel</i> .....	New York,	Bonded.
	Ship <i>Levi Starbuck</i> .....	"	"
" 30	Bark <i>Parker Cook, Fulton</i> .....	Boston,	Burned.
Dec. 5	Schooner <i>Union</i> .....	Baltimore,	Bonded.

Ship *Lafayette* had a cargo consisting of 18,269 bushels of wheat, 47,668 bushels of corn, and 16,860 lbs. of lard.  
 Bark *Lamplighter* had a cargo of 800 bhd. of tobacco.  
 Bark *Laurietta* had a cargo of 1,494 bbl. of flour, 325 kegs of malla, 998 bbl. of flour, 205 boxes of herring, and 7,290 staves.  
 Schooner *Cronshaw* had a cargo of 1,298 bbl. of flour and 2,273 bushels of wheat.  
 Ship *Manchester* had on board 45,141 bushels of wheat and 14,666 bushels of corn.  
 Brig *Dunkirk* had a cargo of 2,967 bbl. of flour and 6,000 staves.  
 Ship *Tonawanda*, her cargo being insured in England, was released on giving a bond for \$30,000. She had a cargo of 49,700 bushels of wheat, 40 bbl. of flour, 86 bhd. of bark, 172 cases of wine, 128 bales of hemp, and 50 bales of hops and rags.

The course of the *Alabama* was to destroy, since under the regulations of foreign powers she had no means of landing and condemning her prizes. Her case is certainly a very peculiar one. She has neither register nor record, no regular ship's papers nor evidence of transfer, and no vessel captured by her has ever been sent into any port for adjudication and condemnation. All forms of law which civilization has introduced to protect and guard pri-

vate rights, and all those regulations of public justice which distinguish and discriminate the legalized naval vessel from the pirate, are disregarded and violated by this famous rover, which, though built in and sailing from England, has no acknowledged flag or recognized nationality, nor any accessible port to which to send any ship she may seize, nor any legal tribunal to adjudge her captures. She was built and fitted out in British ports in alleged violation of British law and of the royal proclamation of neutrality, and her crew is composed almost exclusively of British subjects, or persons who, pursuing a lawful voyage, would be entitled to ship and receive protection as British seamen. Most of the crew sailed from Liverpool to join her, and others volunteered from captured vessels, as in the case of the crew of the ship *Brilliant*. The prize money or half the value of the vessels and cargoes destroyed was, it was stated, regularly paid in money to the crew, who were thus large gainers, and their prosperity tempted the men of captured vessels, from which also supplies were procured. Among the first of the captured were the *Virginia* and the *Elisha Dunbar*. The statements of the captains of those vessels indicate the course pursued by the Confederate commander.

Captain Tilton, of the *Virginia*, says that he was overhauled by the *Alabama* on the morning of the 17th of September, in lat. 39° 10', and long. 84° 20'. The enemy showed British colors, but when a quarter of a mile from the *Virginia* set Confederate colors, and sent an armed boat's crew on board. Captain Tilton was informed that he was a prize to the *Alabama*, and was ordered to take his papers and go on board that steamer. The Confederates then stripped the ship of all the valuable articles on board, and at 4 P. M. set fire to the vessel. Captain Tilton adds:

I went on the quarter deck with my son, when they ordered me into the lee waist, with my crew, and all of us put in irons, with the exception of two boys, cook and steward. I asked if I was to be put in irons? The reply was that his purser was put in irons and his head shaved by us, and that he was going to retaliate. We were put in the lee waist, with an old sail over us and a few planks to lie upon.

The steamer was cruising to the west, and the next day they took the *Elisha Dunbar*, her crew receiving the same treatment as ourselves. The steamer's guns being kept run out the side ports could not be shut, and when the sea was a little rough or the vessel rolled, the water was continually coming in on both sides and washing across the deck where we were, so that our feet and clothing were wet all the time, either from the water below or the rain above.

We were obliged to sleep in the place where we were, and often waked up in the night nearly under water. Our fare consisted of beef and pork, rice, beans, tea and coffee, and bread. Only one of our irons was allowed to be taken off at a time, and we had to wash in salt water. We were kept on deck all the time, night and day, and a guard placed over us.

The steamer continued to cruise to the northwest, and on the 3d of October fell in with the ships *Brilliant* and *Emily Farnham*—the former of which they burnt, and her crew, with ourselves, were transferred to the latter ship, after signing a parole. On the 6th instant

was taken on board the brig *Golden Lead*, of *Thomaston*, Captain Smith, from *Jersey* for *New York*; was treated with great kindness.

Captain Gifford, of the *Elisha Dunbar*, stated as follows:

On the morning of the 18th Sept., in lat. 39° 50', long. 85° 20', with the wind from the southwest and the bark heading southeast, saw a steamer on our port quarter standing to the northwest. Soon after found she had altered her course and was steering for the bark. We soon made all sail to get out of her reach, and were going ten knots at the time; but the steamer gaining on us under canvas alone, soon came up with us and fired a gun under our stern, with the *St. George's* cross flying at the time. Our colors were set, when she displayed the Confederate flag; being near us, we hove to, and a boat with armed officers and crew came alongside, and upon coming on board, stated to me that my vessel was a prize to the Confederate steamer *Alabama*, Captain Semmes. I was then ordered on board the steamer with my papers, and the crew to follow me, with a bag of clothing each. On getting aboard, the captain claimed me as a prize, and said my vessel would be burnt. Not having any clothes with me, he allowed me to return for a small trunk of clothes—the officer on board asked me what I was coming back for, and tried to prevent me from coming on board. I told him I came after a few clothes, which I took and returned to the steamer. It blowing very hard at the time and very squally, nothing but the chronometer, sextant, charts, &c., were taken, when the vessel was set fire to and burnt; there were 65 barrels sperm oil on deck, taken on the passage, which were consumed. We were all put in irons, and received the same treatment that Captain Tilton's officers and crew did, who had been taken the day before. While on board we understood that the steamer would cruise off the *Grand Banks* for a few weeks to destroy the large American ships to and from the *Channel* ports. They had knowledge of two ships being loaded with arms for the *United States*, and were in hopes to capture them. They were particularly anxious to fall in with the clipper ship *Dreadnought*, and destroy her, as she was celebrated for speed; and they were confident of their ability to capture or run away from any vessel in the *United States*. The steamer being in the track of outward and homeward bound vessels, and more or less being in sight every day, she will make great havoc among them.

DAVID R. GIFFORD,  
Late Master of *Bark Elisha Dunbar*.

The *Brilliant* was built in *Boston* in 1861, was 839 tons, and was valued at \$80,000. The Confederate commander, in reply to the captain of the *Virginia*, on protesting against his detention, stated: "You Northerners are destroying our property, and *New Bedford* people are having their war meetings, offering \$200 bounty for volunteers, and send out their stone fleets to block up our harbors, and I am going to retaliate!" The officers were in some cases ironed in accordance with this view of retaliation. The number of prisoners had now increased to 68, and these were placed on board the *Emily Farnham*, which was captured on the same day as the *Brilliant*, and released because the ship's papers showed the cargo to be on *English* account. The large number of prisoners exceeded the accommodations of the vessel, and eight of the number were put on board the brig *Golden Lead*. The *Alabama* landed 170 prisoners at the *Island of Flores*. Her action in relation to *British* ownership seemed to be a little eccentric. When the ship



Lafayette was captured, Capt. Small produced his British consular certificate and remarked he supposed that would be sufficient protection. Captain Semmes replied, "The New York people are getting very smart, but it won't save you; it's all a hatched up mess." He then gave orders to burn the ship. It was the case that the property of a large circle of merchants known to Capt. Semmes was respected much more scrupulously than that of strangers. It is obvious that, as 290 merchants were subscribers to build the Alabama, any of their names upon a manifest would be a safe passport.

When the news of these depredations reached New York great excitement was created. The insurance companies advanced the war risks. British consular certificates were in demand, and freights were placed in British bottoms rather than American. The New York Chamber of Commerce held a meeting in relation to the matter, on the 21st day of October, and a series of resolutions were adopted.

Captain C. H. Marshall submitted the following letter from the Secretary of the Navy:

NAVY DEPARTMENT, WASHINGTON, — 1862.

SIR: I received your letter of the 14th instant, also your letter of yesterday, referring to it, inquiring, as the chairman of a special committee of the Chamber of Commerce, what measures have been taken to capture the rebel pirate Alabama, and also whether the Government will grant commissions to private vessels, if fitted out under promise of reward by citizens, for that purpose. An earlier reply to the inquiry of the committee has been unavoidably delayed. The department has several vessels in search of the Alabama, in addition to the flying squadron of Acting Rear Admiral Wilkes in the West Indies, and other ships of war on the European coast. Additional force will be despatched in this service as early as practicable. There is no authority for granting commissions to private vessels to search for the Alabama or other piratical vessels or privateers. I am, respectfully, your obedient servant,

GIDEON WELLES, Secretary of the Navy.

C. H. MARSHALL, Esq., Chairman.

The events also produced some excitement in England. The vessels destroyed and threatened were those sailing under the Federal flag. But vessels so sailing have hitherto carried more property of British owners than of any others. And as Capt. Semmes burns vessels and cargoes without distinction, and the cargo is commonly much more valuable than the vessel, the English, as a neutral nation, have hitherto been, probably, the chief sufferers. Time, of course, soon changed this aspect of the case. Vessels under the Federal flag became by so much less eligible for safe conveyance; and, though a corresponding premium of insurance will always cover the war risk, it in this case so enhanced the ordinary charges as to put Federal vessels to a very serious disadvantage in the market of freight; thus affording some compensation to English interests.

An attempt was made to obtain redress from the Confederate Government for British losses in the manner indicated in the following correspondence:

To his Excellency the British Minister, Washington:  
PHILADELPHIA, Nov. 7 1862.

EXCELLENCY: As a British subject and a shipper of merchandise upon the ship *Tonawanda*, lately overhauled by the Confederate war steamer *Alabama*, I beg most respectfully to call your attention to this matter.

The *Tonawanda*, as you are no doubt aware, was released from capture, and allowed to proceed on her voyage under a bond of \$60,000, as a ransom, and this sum will be rated upon ship and cargo by the average staters, on her arrival in Liverpool.

I respectfully suggest that your Excellency make application to the Government of the Confederate States that consent be given that all sums so rated upon property belonging *bona fide* to British subjects be remitted, and that the same shall be deducted from amount of said bond of \$60,000, with similar proceedings in all such cases as may arise.

I have also merchandise on board the ship *Lancaster*, American, now in this port, and advertised to sail on Tuesday next. To my bills of lading, which the captain takes with him, I have attached the British consul's certificate that the property belongs to British subjects; but, as it is feared that this may not be sufficient to save from destruction, in the event of capture, I beg that your Excellency will be so good as to furnish me with a letter protesting, as the highest British authority in this country, against the destruction of British merchandise, to be used by the captain of the *Lancaster*, if necessary. Any cost attending such letter I will gratefully pay, and trust your Excellency will think that I only do right in seeking to protect my friends in England from loss, for whom I have shipped these goods, by appealing thus to our own Government.

It will mitigate the horrors of this war if your Excellency shall succeed in preventing the destruction of ships holding certificates of British property, and it will be but just that British merchants should be exempt from contributing to the ransom of ships and merchandise belonging to belligerents. I cannot but think that your Excellency's protest, which I ask for, will be respected on the seas, and also that the Confederate Government will readily grant the exemption desired.

Your immediate action in these matters will, I feel certain, be satisfactory to yourself, and will be hailed with much gratitude by British merchants everywhere, and meet with the approval of the home Government.

I have the honor to be your Excellency's most obedient servant,  
W. H. TRENWITH.

WASHINGTON, Nov. 3, 1862.

W. H. TRENWITH, Esq., Philadelphia:

SIR: I have received your letter of the 7th instant, in which you suggest that I should make an application to the Government of the so-styled Confederate States with reference to the ransom of British property on board American vessels, in consequence of the recent proceedings of the war steamer *Alabama*; and that I should furnish you with a letter of protest, for the purpose of protecting some merchandise which you have shipped on board the American ship *Lancaster*.

While greatly regretting the risk to which British property is exposed by being shipped in belligerent vessels, it is not in my power to accede to either of your suggestions.

You are aware that the so-styled Confederate States have not been recognized by her Majesty the Queen, and for that reason I shall not be justified in entering into communication with the Government of those States, except under special instructions from her Majesty's Government. Neither do I feel at liberty to supply you antecedently with the protest which you desire, having no authority to issue such a document, and seeing no reason to believe that it would insure a more effective protection to your goods upon the high seas

than the consular certificate, with which you seem to have supplied yourself.

I am, Sir, your obedient servant,

W. STUART.

On the 18th of November the Alabama fell in with the steamship Ariel, on her way from New York to Aspinwall. The steamer was bonded and allowed to proceed with her passengers; but the alarm occasioned by her seizure prevented her from bringing back her usual freight of gold. A United States gunboat was sent to bring it. In the mean time, however, it arrived by the next boat of the company. A number of armed vessels were sent out to cruise in the track of the Alabama, without much success. The Vanderbilt sailed from New York for Fayal, December 11. Two other steamers left New York, one from Boston, one from Philadelphia, and one from Portsmouth, N. H. None of these were, however, of sufficient speed. The U. S. frigate Sabine, Com. Cadwalader Ringgold, left New London, November 8, in search of the Alabama. Arrived at the Azores November 28. Sailed thence December 2, and arrived at Cape de Verde December 23, and left there January 2. Absent 100 days, cruising 93 days, and sailed 10,000 miles in vain.

The Alabama meantime, having captured the Ariel on the 18th, arrived on the 26th, two days before the Sabine reached the Azores, at Martinique, where she took in coal from a British bark. The United States steamer San Jacinto, at the same date, was off St. Thomas watching for the Alabama, which on the 30th captured the Parker, Cook, off the Moro Passage. December 5 she captured the Union off Cape Mais, and was off Havana December 31. Thus she does not appear to have left the American coast, while the Vanderbilt and other vessels sent in search were seeking her elsewhere. In some cases the Alabama released her prizes on a ransom bill being signed by the captain, and agreeing to pay a sum of money after the close of the war. By the general law of nations these bills or contracts are recognized as between belligerents, and a captain may by his contract bind his owners, the whole cargo as well as the ship. Those ransoms were forbidden by the English Government under George III, but have never been prohibited by the United States.

The theory of ransom is that it is a repurchase of the actual right of the captors at the time the bill or bond is given, be that what it may; or, more properly, it is a relinquishment of all the interest or benefit which the captors might acquire or consummate in the property by regular adjudication of a prize tribunal, whether it may be in the interest of the ship and cargo, or a lien on the same, or a mere title to expenses. These ransom bills are, by rules of international law, an exception to the general doctrine that no contract with an enemy is valid.

In the case of the ransom bill given by the Ariel, it seems not to be payable till six months after the recognition of the Southern Confederacy. If then, that contingency should happen, what court would have jurisdiction to enforce the agreement? Primarily, all questions of prize belong to the tribunals of the capturing power; and foreign tribunals will not interfere, unless where their territorial rights have been violated. Ransoms belong to the same jurisdiction, and may there be enforced or set aside, as the facts disclose a good or bad prize. It is, however, competent for the captors to change the *forum* in cases of ransom, and apply for redress in any country where the person of the owner of the Ariel may be found, or the ship itself.

A CORRECT SKETCH OF THE CONFEDERATE STEAMER "ALABAMA'S" HULL, WITH THE POSITION OF THE SHOT HOLES AFTER THE FIGHT WITH THE "HATTERAS;" ALSO THE POSITION AND WEIGHT OF HER ARMAMENT.

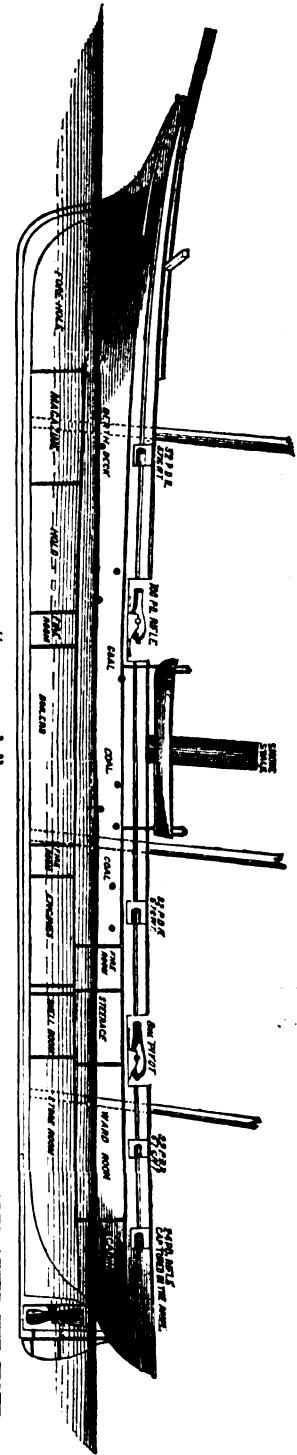

On the 11th of January, 1863, about 8 P. M., as the Federal squadron, consisting of the steamers Brooklyn, Hatteras, and five others, was cruising off Galveston, a vessel hove in sight at the southeast, which the Hatteras was ordered to proceed to and learn her character. As she came in sight she appeared to the officers of the Hatteras to be endeavoring to escape. Just after dark the officers of the Hatteras could perceive that she was bark rigged, and set a topgallant sail; and, as they approached, found her lying to, under steam. The crew of the Hatteras were at quarters, and Capt. Blake hailed and asked what ship it was. The answer was, "Her Britannic Majesty's ship Spitfire." Capt. Blake replied that he would send a boat aboard. The Alabama ranged a little ahead, her officer declaring that she was the Confederate steamer Alabama, and immediately opened fire on the Hatteras. It was returned by the Hatteras, and both started ahead under a full head of steam, exchanging broadsides as fast as they could load and fire.

The heavy guns of the Alabama soon disabled the Hatteras, so that it was impossible to keep her afloat. Two guns were fired to the leeward, the contest ceased, and the officers and crew of the Hatteras, which soon sunk, were taken to Kingston, Jamaica, and paroled.

The following were the principal officers of the Alabama: Captain, Raphael Semmes; First Lieutenant and Executive Officer, J. M. Kell; Second Lieutenant, R. T. Armstrong; Third Lieutenant, J. D. Wilson; Fourth Lieutenant, J. Low; Sailing Master, Arthur St. Clair; Surgeon, F. M. Galt; Assistant Surgeon, R. H. Lewellen; Lieutenant of Marines, B. K. Howell; Engineer, Michael Freeman; Paymaster, C. T. Young (since discharged); Midshipmen, Maffit (son of Capt. Maffit, of the Oreto), St. Clair, Bullock, and Anderson.

The Alabama was supposed not to be the only vessel built in England for the Confederate service.

NAVY, UNITED STATES. The organization of the Navy Department of the United States embraces a secretary and two assistants; a bureau of navy yards and docks; a bureau of construction and repairs; a bureau of provisions and clothing; a bureau of ordnance; a bureau of medicine and surgery; a bureau of steam engineering; a bureau of equipments and recruiting; a bureau of navigation, embracing the naval observatory and hydrographical office.

The officers of the navy, by an act of Congress of July 16, 1862, are divided into nine grades, taking rank according to the date of commission in each grade, as follows:

- |                       |                 |
|-----------------------|-----------------|
| 1. Rear-Admirals,     | 6. Lieutenants, |
| 2. Commodores,        | 7. Masters,     |
| 3. Captains,          | 8. Ensigns,     |
| 4. Commanders,        | 9. Midshipmen.  |
| 5. Lieut.-Commanders, |                 |

Their rank as compared with officers of the army is as follows:

Rear-Admirals	to rank with	Major-Generals,
Commodores	"	Brigadier-Generals,
Captains	"	Colonels,
Commanders	"	Lieutenant-Colonels,
Lieut.-Commanders	"	Majors,
Lieutenants	"	Captains,
Masters	"	First Lieutenants,
Ensigns	"	Second Lieutenants.

The number of officers of each rank, at the close of the year, was as follows:

	Active list.	Reserved list.	Retired list.
Rear-Admirals.....	4	..	9
" " acting....	5	..	..
Commodores.....	16	..	16
Captains.....	89	10	22
Commanders.....	90	11	7
Lieutenant-Commanders.	144	..	..
Lieutenants... ..	104	17	6

The vessels of the navy building and in service, and the number of guns carried by them, and the class to which they belonged, were on Nov. 1, 1862, as follows:

STREAMERS:		
	No. of vessels.	Guns.
Side-wheel steamers.....	102	623
Screw steamers.....	114	673
Iron-clad steamers.....	58	266
Steam gunboats and rams.....	13	67
Total.....	287	1,527
SAILING VESSELS.		
Ships and frigates.....	12	604
Sloops-of-war.....	21	846
Mortar fleet.....	19	56
Ships, barks, brigs, &c.....	50	124
Total.....	102	1,400

The vessels in service have formed the following squadrons: West Gulf squadron, 59 vessels; West Indies, 8 vessels; East India squadron, 3 vessels; Mediterranean, 6 vessels; Pacific squadron, 5 vessels; South Atlantic blockading squadron, 63 vessels; North Atlantic blockading squadron, 65 vessels; Western Flotilla, 79 vessels; East Gulf squadron, 24 vessels; Potomac fleet, 21 vessels; coast of Africa, 1.

For the operations of the navy in contest with the Confederate forces, see NAVAL OPERATIONS, and ARMY OPERATIONS.

The most important subject before the Government and people of the United States relative to their navy respects the iron-clad vessels. The operations of the Government during the year, with the principles that have been developed, and the improvements which have been made relative to these vessels, so far as they are allowed to be known, are presented in the annexed pages.

IRON-CLAD, OR ARMORED VESSELS.—The ground occupied by either army in an engagement in open field being of uncertain character and extent, and liable to continual change, it results that here no definite system of defence is practicable, and that a land battle is chiefly waged, on both sides, in the way of offensive operations. On the contrary, in naval engagements, and those carried on from within fortifications, the area and objects against which the assault is directed are limited and well defined; in effect, the ground (so to speak) of the defending party is for the time not only small but unchangeable. However simple and obvious this distinction, it is radical, and one that is even now developing consequences of

the utmost importance. Thus, it is in the case of ships and forts alone that the problem and means of defence become equally essential with those of offence; and that the former, like the latter, are of a highly definite and special character, and only to be advanced through careful study of the mechanical and other conditions involved. In fact, in the case of ships, it is most distinctly seen to be true that, when the defence can no longer be improved so as reasonably to keep pace with increasing efficiency and power in the means of assault, the necessary alternative must be the abandonment altogether of naval warfare, or the comparative worthlessness, at the least, of any resort to it. Now, since the early part of the present century, a steady increase has been going forward in the caliber of ordnance and in its available power, that is, in other words, in the penetrative and, generally, the destructive effect of projectiles; while the course and prospects of a naval engagement have been, in a particular manner, changed by the introduction of the so-called Paixhan guns, which throw shells of great weight and at a velocity sufficient for penetrating the wooden sides of the ordinary ships of war, preparatory to spreading destruction and conflagration within them. It is these facts that have forced upon military authorities of the time the specific problem of defence, especially for all classes of war vessels, and so urgently that within the past three years it has become the paramount question in connection with the practice of warfare. Under such circumstances, the subject can, of course, only be presented as one in a state of progress—its results being not merely still undecided, but for the present beyond even the reach of conjecture.

*The Necessity of Armor Recognized.*—A ship or boat, then, being a definite point or object of attack, and the penetration and destructiveness of solid and hollow shot having been gradually and very greatly increased, the inevitable consequence was that, sooner or later, wooden war vessels must become too vulnerable to leave even a reasonable chance of their withstanding a well-directed fire. And, this point once reached, the idea of seeking a more efficient resisting material in some metal, and naturally in iron, must, by a necessity just as inevitable, have presented itself; so that it becomes a matter of slight importance at what precise time, or by whom, the suggestion of such a change was publicly made. By some authorities the proposition is accredited to Mr. John Stevens, of New Jersey, its date about the year 1811; by others, to Col. Paixhan, of the English army, some ten years later.

Among the earliest systematic experiments with a view to the substitution of the resistance of iron for that of wood in the sides of ships, were those made by English authorities in the year 1840, and a few years following, in the way of firing upon targets representing a portion of the side of an iron ship, as ordina-

rily constructed. As a result, it was found that the thin plates of such ships, when struck by projectiles that pierced them, crushed into fragments, which were scattered with peculiarly destructive effect; so that ordinary iron ships were wholly unsuitable for war purposes. A definite proposal for constructing shot-proof iron floating batteries was, about the year 1852, entertained by the United States Government; but the results of experiments made with a view to that end being deemed unfavorable, the project was, for the time, abandoned. Still, the subject was more or less under discussion in this country, and in France and England. It is said that, many years previously, an imperfect attempt had been made at mailing the English ships which took part in the battle of Algeiras (1801), and that, subsequently to that occasion, M. Montgéry, of France, had published several memoirs on the subject. The project having become, in that country, in a degree forgotten, attention was again called to it during the war between France and Russia, by the circumstance that wooden ships were found incapable of withstanding a skilfully-directed fire from near land batteries. The French emperor directed, in 1854, that experiments should be made with a view to the protection by iron armor of ships of a draught rendering them suitable to be employed in an attack on Cronstadt. Upon a renewal of some experiments discontinued about 15 years before, the conclusion was reached that, in order to afford protection against the round shot then in actual use, a thickness of  $\frac{1}{2}$  mètré = 3.987 inches, was required. Of the armored boats or floating batteries hastily constructed in accordance with these views, and which, from the weight of the plates and the depth of water they drew, were incapable of speed, and even of independent navigation, three that were taken to the French fleet, then before Kinburn, participated in the attack, Oct. 1855, on the forts at that place. Though struck by very many 24-lb. balls at about 600 yards, the armor of these boats was not actually pierced, but only somewhat deeply indented; but considerable injury was done by shots which entered the portholes. Some British batteries of like construction did not arrive so as to take part in the action.

In the year 1854, experiments in relation to iron armor were also made in England; in these, a target, consisting of a wood backing covered with wrought-iron plates of  $4\frac{1}{2}$  inches thickness, and intended to represent the side of an armored ship, was found to be indented at 400 yards by 82-lb. solid shot and 8-inch and 10-inch hollow shot, to depths respectively of  $1\frac{1}{2}$ , 1, and  $2\frac{1}{2}$  inches; while 68-lb. solid shot, fired with 16 lbs. of powder, penetrated the plates, splitting them especially in the line of the bolt-holes, which were about 1 foot asunder. In France, a new interest was awakened, by the comparative success of its trial at

Kinburn, in the subject of iron armor; and, in experiments in which 50-lb. balls were fired at several yards' distance, and with a heavy charge of powder, upon plates of the thickness already adopted, it was found that the balls sufficed to break the plates, though they did not go through them. The results, however, differed much with differences in quality of the iron; and, if not previously admitted, it now became evident that, for resistance to shot, a somewhat soft iron is preferable to an iron having great hardness, with its attendant brittleness. The experiments undertaken in the United States had tended to show that, for guns of the largest caliber then in use, although 4½-inch plates, well backed with solid timber, were likely, for a time, to resist piercing by shot thrown from considerable distances, yet nothing less than 6 inches of iron plating could be relied on to render a ship practically invulnerable. This result was discouraging, in view of the fact that the complete armoring of a ship with 6-inch plates appeared to involve a weight which no vessel can carry without great sacrifice of speed, and a loss even of capacity for open-sea service.

The next step in the construction of iron-clad ships (French, *vaisseaux en cuirassés*, or *navires cuirassés*), was the building of *La Gloire* in France (1860), and of the *Warrior* in England (1861). The armor of these ships is described in the preceding volume of this CYCLOPEDIA. Sir Howard Douglas has lately asserted in substance that both these ships are failures, so far as sea-going qualities, speed, and the stability requisite for successful firing upon a heavy sea, are concerned. Both appear to be, with combined armament and armor, overloaded, and owing to the lowering, in consequence, of the *meta-centre* (centre of pressure of the liquid displaced) to near the place of the centre of gravity, both these ships roll in a heavy sea with quick and considerable movements, so that the gunner's aim in such cases becomes extremely uncertain. Moreover, while *La Gloire* has not exceeded 11, in place of the 13½ knots an hour anticipated, and the *Warrior* at sea not more than 12, the latter can carry but 9 days' coal, and in long voyages must often rely on tenders or sails. Apparently, therefore, these ships, and, probably, the others armored by the two nations upon respectively the same patterns, are not, on the score of their capacity for distant expeditions and aggressive warfare, very greatly to be dreaded.

*The Revolving Turret, or Cupola.*—But while ships may possibly be so armored as to be in the main nearly impregnable to an enemy's fire, yet their portholes remain subject to the entrance of shot, and that in proportion to the size that must be allowed for properly working and pointing the guns; while the lateral sweep in this way secured is always limited, and the entire ship must often be manœuvred in order to bring the guns into the desired line. If, however, instead of the ordinary casemate

or broadside arrangement, the guns can be placed within a protecting structure which can be revolved into any required line of fire, all the difficulties connected with the management of the guns, the exposure incident, and the continual effectiveness of the ship's armament, vanish or are reduced to their minimum. Such is the idea of the revolving turret or cupola, and such the objects to be attained through its use. The original invention of this important addition of the last few years to the means of naval warfare, has already been claimed on behalf of three persons, Capt. John Ericsson of New York city, Mr. Theodore R. Timby, of the State of New York, and Capt. Coles, of the British navy. In the year 1854, Capt. Ericsson forwarded from New York to the emperor Napoleon a communication (dated Sept. 26) in reference to a new form of armored vessel for naval attack, designed by him—the plan embodying many of the features of the "Monitor," presently to be referred to, but especially those of a deck rising but a few inches out of water, and of a turret amidships to contain one or two large pieces of ordnance, and to be capable of being revolved so as to bring the guns into any desired line of fire: the shape of this turret, however, was that of a dome, or half a hollow globe, the ports being at one side. The receipt of the communication was duly acknowledged by the emperor. Capt. Ericsson further states that the idea of a revolving tower for ordnance upon land is very old; but that the thought of placing such a structure upon a ship was original with himself, having been conceived many years before the time of the communication above mentioned. Capt. Coles, in a letter to the (London) "Times," April 5, 1862, states that the idea of building impregnable vessels was suggested to him by his experience in the Baltic and Black seas, in 1855, and that toward the close of that year he had a model for such vessels made, in which he proposed to protect the guns by a stationary "shield" or "cupola." Notwithstanding official neglect, he persevered, producing in March, 1859, drawings of a "shield fitted with turntables;" and in December, 1860, he published an account, with drawings, in which the platform of the shield was to be turned by manual power. Mr. Timby constructed, in 1841, a model of a revolving tower for land fortifications, pierced with one or two tiers of portholes, and to contain several guns, these to be fired in succession as they were brought by the revolution in line with the object of attack. A larger model was exhibited in many places in 1843, among others in New York, notices of it appearing in the "Evening Post" of June 13, of that year, and in the "Herald," during the same month. It will be seen that the purposes and principle, on the one hand, of the Ericsson and Coles turrets (accounts of which will be given farther on), and on the other, of that of Mr. Timby, are wholly distinct: with the former, the revolution of the tower is not

the object sought, only so far as needful to point the guns upon the enemy; in the latter, the revolution is indispensable, as well as nearly continuous—a condition that must involve important difficulties in practice. So long as it revolves properly, the Ericsson turret serves to keep an enemy continually under fire, in spite of changes of position. In this way, two guns become—supposing no necessity of delay from their heating—equal in effective force to at least eight mounted on stationary carriages.

*Earliest American Iron-clad Vessels.*—"It so happens," Admiral J. A. Dahlgren very appositely remarks in his Report supplementary to the Report of the Secretary of the Navy, Nov. 22, 1862, "that circumstances impose on England and France the necessity of grappling with the most difficult solution of the problem [that of armoring ships], their shores being washed by the deep waters of the ocean; therefore their iron clads must be more than mere floating batteries, and be possessed of the best nautical qualities. With the United States the case is, happily, different—the depth of water on the coast being generally adapted to vessels of light or moderate draught, and only a few of our ports being at all accessible to heavy iron clads like those of France and England. The solution of the question is, therefore, in its immediate requirements, comparatively easy and inexpensive for us. Vessels of the Monitor and Ironsides class are likely to serve present purposes sufficiently well, and to give time to obtain, from our own and the experience of others, better data than can now be had for advancing to a more perfect order of vessels." The facts here stated in respect to the general character of the coast navigation, Atlantic and Gulf, of this country, as also the great extent to which naval operations may require to be carried on in navigable sounds, bays, and rivers, but which are not always of great depth, have been kept in view in all the earlier attempts here made in the way of armoring vessels—with the single exception, indeed, of the first of them all, the Stevens Battery, the proposed draught of which is 21 feet. (For a full description of this battery, as well as of Capt. Ericsson's first iron-clad battery, the Monitor, the plan of which was one of the three first adopted by the United States Government, in 1861, see the preceding volume of the CYCLOPEDIA.) Of these three patterns of iron-clad vessels, and the draught of which ranged from 10 to 13 feet, all were in fact mainly new in conception, differing from the earlier French and English batteries in being intended to realize independent navigation and fair speed, and from the *Gloire* and *Warrior* styles in being of much less dimensions, while also nearly or quite completely mailed. The most original in principle of the three, and the one that has come to be regarded as peculiarly the American style of iron-clad vessel, was the Monitor—a name that is now employed as distinctive of the growing class of vessels involv-

ing the same general construction. The Monitor was built at the Continental Works, Greenpoint, L. I., by Mr. J. F. Rowland, under the direct supervision of Capt. Ericsson, and delivered to the Government, March 5, 1862. The vessels completed in accordance with the other two of the three contracts, were, for that with the firm of Merrick & Sons, Philadelphia, the *New Ironsides*, and for that with S. C. Bushnell and Co., of New Haven, Conn., the *Galena*.

The experiments preceding the inception of the Monitor had already determined that, since very hard and brittle plates are proportionally more liable to crack, and very soft ones to be simply punched or penetrated, for armoring in the modes thus far adopted, neither steel or hard cast iron on the one hand, nor copper or the softest wrought iron, on the other, should be employed, but in fact an iron possessing fair forging and rolling qualities, and having along with moderate hardness also a high degree of absolute strength or tenacity. In the case, however, of armor applied, not in a single thickness or plate, but in a succession of thinner plates (laminated armor), a harder iron or steel is said to be used with advantage. It will be remembered that the armor of the upper hull of the Monitor consisted of 5 inches of rolled iron (1-inch) plates; that of the turret generally of 9, and that of the deck of 2 inches of similar plating. Of course, though in England there is an apparently open avowal and discussion of all information acquired in respect to penetration of projectiles and qualities of armor indicated, it is probably true that in all the leading countries now interested in this question, as is evident in the case of the Government of the United States, there is nevertheless a degree of reticence in respect to important results, and especially as to certain points in the construction, armament, and working of iron-clad vessels. Hence, there are portions of information in regard to these subjects which can only become public after the lapse of a few years, or under a condition of national questions different from that which now exists.—An account of the experiments in the way of testing the relative capacities of the most recent and improved ordnance and iron armor, with the bearing of the results on the questions of thickness, kind, quality, and extent of armor protection for vessels, as well as of the modes in which the plates are prepared for being applied, will be given farther on.

*The First Class Monitors (Smallest Size).*—The course and result of the engagement between the Monitor and Merrimac, in Hampton Roads, March 9, 1862, having established the suitability and success of the Ericsson form of battery, both for purposes of defence (at least, against guns of the power there employed) and of attack, orders were speedily issued by the U. S. Government for the construction of 10 similar batteries, one or more of which, indeed, must have been at the time already com-

menced. The following are the vessels included in the orders referred to:

Name.	Where built.	Date of Launching.
1. Passaic.....	Greenpoint, L. I.....	April 31, 1862.
2. Patapsco.....	Wilmington, Del.....	Oct. 1, "
3. Nahant.....	Boston, Mass.....	Oct. 6, "
4. Montauk.....	Greenpoint, L. I.....	Oct. 9, "
5. Nantucket.....	Boston, Mass.....	Dec. 6, "
6. Lehigh.....	Chester, Penn.....	"
7. Sangamon....	" ".....	"
8. Catskill.....	Greenpoint, L. I.....	Dec. 6, "
9. Weehawken.	Jersey City, N. J.....	"
10. Camanche...	" ".....	"

These batteries were built and armored substantially in accordance with the plan of the original Monitor, but of somewhat larger dimensions, and with some important modifications introduced from the start or when near their completion, as suggested by further experience in working vessels of a style so unusual. Exteriously, they show an upper and broader portion of hull, heavily armored and nearly vertical, and a much shorter, as well as narrower lower portion of hull, not armored: the form of the actual hull (of iron), however, appears only from within, being somewhat modified from the shape usual in vessels of like size, and not unaptly compared to that of the half of an egg-shell cut lengthwise. Their decks are mainly clear, and intended to rise but from 18 to 30 inches above the water. They are rated at 844 tons burden; and they have each 1 turret, revolving, and a total armament of 2 guns, now, generally, of 11 and 15 inches caliber. Their construction being substantially the same, a description of one of these batteries will serve for the whole class.

The Passaic has a length of upper hull equal to 200 feet, width 45 feet, total depth 12 feet, draught of water when laden 10½ feet. The lines of the hull are finer than those of the first Monitor, and the buoyancy and speed greater. The hull of the vessel is first built of ¾-inch iron plating, fastened upon a frame of angle iron, of 6 inches width by ¾-inch thickness. The broader upper portion of the hull commences at about 5 feet below the deck, that is, 3½ feet below the water line, by a sort of horizontal iron shelf, upon which is first built up the wood backing for the armor, consisting of solid oak, to a thickness of more than three feet, and braced with iron. Over this is applied the armor, consisting of 5 thicknesses of wrought-iron plates, each 5 feet in length and width. In addition to and beneath this, for a distance of 50 feet from the bow, in the Passaic, are inserted a succession of wrought-iron stringers 4 inches thick, the two combined being equivalent for this part of the boat to 9 inches of solid armor, and giving it immense strength for use as a ram. The deck beams are of oak, 24 inches apart, 12 × 12 inches at the middle, and 12 × 10 at the ends. Over these is a pine planking 8 inches deep; and upon the whole two thicknesses of 1-inch plating. The hatches are of wrought iron, and let in flush with the deck; in action they are closed with covers of like material, secured be-

low. Within, the vessel is strengthened forward of the turret bulkhead by three rows, and aft of the bulkhead by one row, of stanchions of 23 × 4 bar-iron, fastened with 1-inch bolts; and there are six water-tight compartments, formed by ¼-inch plates properly secured, and between which communication is furnished by means of doors. The turret has an internal diameter of 21 feet, height 9 feet. Its sides are composed of 11 thicknesses of 1-inch plating, each in 20 vertical sections, but so put on that at any part in the entire thickness but a single joint occurs. It rests on a flat ring of composition metal, 12 inches wide by 1½ thick, and provided at its inner edge with a vertical flange of like thickness, and 2½ inches in height. The pilohouse, with a total diameter of 7 feet, 4 inches, rests on the top and middle part of the turret, the general framework of the top consisting of stout forged iron beams alternating with others resembling railroad bars, these being respectively three inches apart. Over these, on the part of the top not occupied by the pilohouse, is a covering of ¼-inch wrought-iron plates, these being perforated at certain parts with holes 1 inch in diameter, for the supply of air to the turret and hull. The pilohouse, 6 feet in height and in interior diameter, is formed of 8 inches of plates, and is pierced with 8 lookout holes, each giving a horizontal range of vision of 45°, so that together these render every part of the horizon visible from within. The turret has 2 portholes near together; and the armament is an 11-, and a 15-inch Dahlgren gun. The portholes are closed with ponderous portstoppers, each weighing more than 6,000 lbs.; one man can readily open these preparatory to firing, and close them immediately afterward. The engines, 2 in number, built at the Delamater Iron Works, have cylinders of 40 inches diameter, and 22 inches stroke. There are 2 boilers, of Martin's plan, each 9 feet 3 inches in height, and 12 feet 6 inches long, with 3 furnaces. The propeller is of cast iron, 12 feet in diameter, and of 16 feet pitch.

The hull and armor-shelf of this battery (save about the upper 2 feet of height) being, when the vessel is afloat, below the water, and the unarmored portion of the hull being in effect removed 5 feet within the sides, and descending in all but a few feet below them, it results that no shot fired upon the battery can reach this lower portion without first having penetrated the armor and timbers, or in the rare case of coming at a very small angle with the water, having its force quite expended before striking. Moreover, the armor-shelf or platform, which projects no more than 5 feet at the sides, is extended at the ends so as to project at the bow full 16 feet beyond the boat proper or hull, and at the stern 25 feet. The effect of this arrangement is to give complete protection to the anchor and capstan within the bow, and the propeller and rudder at the stern. A propeller well opens from the deck through the aft over-

hang, while through the fore overhang is an anchor well, 5 feet in diameter, and so arranged that the anchor—a patent form, with 4 flukes—can be taken up through it.

Among the important changes from the plan of the first Monitor introduced generally in the new batteries, the following should be particularly named: 1. While the former had the sides of its lower hull sloping at an angle of 80° to the vertical, and a flat bottom, the latter have more nearly an ordinary midship section, with an ordinary rise of floor, and a round bilge. 2. While, in the former, the turret received the support of but a single bulkhead running across the vessel, the turrets of the latter receive support from 4 bulkheads, 2 transverse and 2 longitudinal, and which are heavily braced with "angle bars." 3. The overhang at the stern is greatly reduced in the new batteries, so that in a seaway they are correspondingly less subject to strain on this account. 4. The new batteries only are provided with a heavy iron-plate chimney, which rises about 6 feet above the deck. In these, accordingly, the retraction of the chimneys through the deck during an action is not required. 5. In them, also, the air supply is more safely and effectually obtained through the top of the turret, the blowers, driven also by blower engines of larger size, being placed just beneath the turret flooring, and acting to force air into the boiler room and other parts of the hold. The guns within the turrets, moreover, do not usually require sighting, since the direction of fire can be found and kept by means of the "turret sight," fixed parallel with the guns before a small opening in the wall.

Besides the 9 new Monitor batteries first ordered, others involving further variations of plan or dimensions have been commenced at different places. In January, 1863, the *Osage*, one of these, was launched at St. Louis, Mo. This boat is 180 feet in length, having 1 turret and 2 11-inch guns, the deck oval and at the edge only 12 inches above the water, and with an oval pilothouse at the stern. The *Camanche* was constructed in sections, to admit of being taken apart for transmission to California, for protection of the coast of which country she was designed. Another fleet, of 8 Monitors of the first class, and of dimensions differing not much from those of the previous ten, are now in course of construction.

*Improvements in Working the new Monitors.*

—In the first Monitor, the guns were run out for firing, so as to project through the portholes; and they were, of course, exposed for the moment to increased danger of being struck and disabled. Besides, it was becoming desirable to substitute guns of 15-inch for those of 11-inch caliber; and while, when this change was decided on, some of the turrets were already bored with portholes of the original dimensions—for 11-inch guns—it was desirable also, in view of saving the strength of the turret and diminishing risks of entrance of the

enemy's missiles, to keep the portholes as small as possible. All the ends indicated could be subserved at once, if it were practicable to discharge the guns within the turret. To this important problem, involving such particulars as the means of reducing greatly the recoil of the piece on firing, as also the question of the effect of the concussion and reverberation on those within the turret, Capt. Ericsson diligently applied himself. An apparatus for the guns was devised, the details of which have not been made public, but which was intended to control the action of the piece in the moment of firing, especially in the way of allowing of all needful recoil within the limits of the turret. November 15, 1862, a short trip was made up the Hudson river, with the *Passaic*, for the purpose of experiments with the new apparatus, among those on board being Admiral Gregory, general superintendent of iron-clad vessels, and chief engineers Stimers, Lawton, and Robie. Three hollow shot weighing each 330 lbs. were successively fired, in the direction of the Palisades on the west bank of the river, from the 15-inch gun within the turret; the first, with a charge of 20 lbs. of powder, the other two with a charge of 35 lbs. each; and the recoil was found to be brought wholly within control, being 17 inches for the first shot, 8 ft. 10 in. for the second, and 2 ft. 8 in. for the third. It appears that the recoil is diminished by means of a friction apparatus of peculiar form; and the excessive recoil of the second shot was due to the circumstance that the screws or "compressors" in the apparatus had not been properly tightened beforehand. No inconvenient effect from the concussion was experienced by those within the turret. Thus the entire feasibility of discharging the piece within the turret was demonstrated; and a few days subsequently orders were sent from Washington directing that the turrets of all the Monitors be at once completed with portholes of the original dimensions.

Again, in view of the ease with which the great guns now employed on these batteries, and especially as fitted with the new apparatus, can be served, it results that a very great economy in the requisite force of gunners, and in expense is secured. Thus, while 25 men have been found insufficient to serve a single Armstrong gun on shipboard, its weight only 14 tons, it is here true that 6 men serve efficiently and with ease the two guns of the *Passaic*, the 15-inch one weighing 42,000 lbs., and with a charge of 35 lbs. of powder, throwing a 450-lb. solid shot, or a shell of the weight above mentioned. The total complement of officers and men for each of these Monitors is less than 100.

Among other improvements in working the Monitors, and, as well as the preceding, several by plans of Capt. Ericsson's invention, are those by which the bed of the turret is rendered water tight; the arrangement for using the compass, when not in action, free from the



interference due to the attraction of the iron mass of the battery itself; and the consequent plan of steering by a mirror. The leakage occurring under the turret in the first Monitor, when her deck was washed by a heavy sea, was a serious inconvenience. Means have now been devised by which, while the turret has the requisite freedom of movement, the leakage beneath it is wholly prevented. In the new arrangement of the compass, this is raised far above the disturbing influence of the iron turret and deck; while, by means of mirrors suitably placed, the movements and position of the needle are rendered perfectly visible to the helmsman at his place within the pilothouse.

In reference to the sea-going qualities of the Monitors, repeated experience has shown that though in a storm or heavy sea the waves continually break or roll over their decks, yet they possess remarkable stability and steadiness of movement; and since they are now rendered water-tight, save for the water, easily removed by the pumps, that may enter by the top of the turret, they are safe against all casualties except such as may arise by grounding on rocks or springing a leak, and to which all vessels are exposed. Again, since the boiler fires need no longer be interfered with by influx of water, and the boilers and engines must continue to perform more successfully in a tempest than those of vessels which pitch and roll more, it follows that their chances of weathering a storm are even better than the average for vessels generally, and that they may safely undertake sea voyages of any length for which the coal they carry will suffice. On the 20th and 21st of January, 1863, the Weehawken outrode successfully and without inconvenience, while on her way to Hampton Roads, one of the severest gales known to our coasts. The speed of these batteries has not exceeded about 8 knots an hour.

Up to the time of the attack (April 7, 1863) on the forts in Charleston harbor—full particulars of which cannot be included in this article—the new batteries had taken little part in actual service. The Montauk was engaged during at least three hours in the attack on Fort McAllister, on the Ogeechee river, Feb. 27, 1863; and while her shot told with great effect on the loose sand works of the fort, the 40 shot received upon every exposed part of the battery herself, and consisting of rifle bolts and 8 and 10-inch solid shot, occasioned no actual damage to her, but served to show the possession of invulnerability in a very high degree. The 5 or 6 shot which struck the deck glanced, leaving only slight furrows in the upper plate. The shot striking the side armor of the battery (5 inches) were smashed, and left on the armor dints of about  $\frac{1}{4}$  the area of their greatest section, and an inch in depth. Upon the turret (11 inches of plates) and the pilothouse above it (8 inches), the results were similar, save that the dints were not so deep. Within, no perceptible ef-

fect of the blows remained, except in the pilothouse, where 7 of the bolt-heads, which had been screwed up too tightly, were broken off by the concussion of the shot striking the plating, or perhaps by the slight recoil of the plates after concussion, and so were projected from the wall into the enclosed space. There was nowhere any sign of penetration. The 15-inch gun was handled with ease; and no annoyance resulted from the discharge, the concussion, or the smoke, nor from the impact of the enemy's shot, except that the blast from the guns returned through the eye holes of the pilothouse, so as to prevent observing the effect of the practice. In fact, but a part of the shot of the Montauk were directed against the fort, her principal fire being aimed at the ship Nashville, lying under its protection. This vessel she destroyed; and the instance is the first in naval history in which a war vessel, safely disregarding the heavy fire of fortifications, has effected the destruction of her antagonist lying under cover of their guns. After the action, the immense weight of the turret (160 tons), which is supported upon a central shaft, had caused a slight settling; but the shaft being keyed up from below, the turret again revolved freely.

In the attack at Charleston, above referred to, the New Ironsides, flagship, the Monitors Weehawken, Passaic, Montauk, Patapsco, Catskill, Nantucket, and Nahant, and the Keokuk, were engaged. The conflict lasted in all about two hours, the iron-clad vessels carrying all together but 32 guns, and firing only 151 shot. During nearly three quarters of an hour, they sustained the converging fire of the Cumming's Point battery, Forts Moultrie and Sumter, and Battery Bee, these probably mounting in all not less than 800 guns, which threw 8, 9, 10, and 11-inch round shot and shell, and 5 and 6-inch rifled shot, some of the latter evidently from guns of the latest Whitworth pattern—the whole number of shot supposed about 3,500. It has been stated that, as a result of the fire of the fleet upon Fort Sumter, several holes were knocked through the northeast face of the wall, one or more of these apparently 8 feet across. While the number of guns in the fleet was very small, it was practically reduced about one half, by the failure to bring the casemate guns of the New Ironsides to bear upon the fort, beyond the extent of a single broadside. The firing commenced and ceased at about 1,800 yards; during the period in which it was at close quarters the range varied from 800 to about 600 yards. In the conflict, the Passaic was hit 58 times, one of the shot hammering down the plating at the point struck at bottom, so as to cause it to bind, and interfere with the turning of the turret; while the gun-slides on which the 11-inch gun were placed were also sprung. The Weehawken was struck 59 times; the Montauk 20; the Nantucket 51; the Catskill about the same number of times; the Patapsco, 40, and the Nahant about 80 times. The armor of the

Monitors, including the plating of the decks, turrets, and pilothouses, was considerably dented; but nothing like fracture of the armor or turrets occurred, and nothing approaching to penetration. In one or more instances a shot ploughed its way, while glancing, nearly or quite through the thinner plating of the deck. Nor was the propulsive machinery of any of these vessels damaged. The only casualties within them occurred by the snapping off, in the manner before referred to, of some of the bolt-heads inside the pilothouse of the Nahant—these not having been covered, as they were in most of the Monitor fleet, with sheet-iron guards: four of the officers and men of the Nahant were wounded by these bolts, one of the men mortally. The entire list of wounded upon the fleet was but 13, the remaining nine of these on the Keokuk; and the only fatal wound was in the case already named.

*Loss of the Original Monitor.*—The loss of this now world-famous battery, which occurred off the coast of North Carolina, Dec. 31, 1862, during a violent gale which commenced on the previous day, although an accident that appears to call for regret from national considerations as well as for the painful sacrifice of life attending it, could not serve to overthrow the conclusions already expressed in respect to the sea-going qualities of the Monitor batteries; and especially so, since the 10 new vessels of the sort, built under less urgency in respect to time, were also constructed expressly with more regard to fitness for navigation and sea service. The Monitor was in tow of the Rhode Island, and, the water which entered the hold gaining so as to stop the working of the engines, at about 1 30 p. m. of the 31st, she went down. Four of her officers and nine men, as well as eight men of the Rhode Island, were lost.

*A New Life-raft,* devised, or at least completed, since the sinking of the Monitor, has been supplied to several of the new Monitors, as well as, of course, to other vessels of the navy. This raft consists of several watertight hollow air-filled cylinders of canvas coated with gutta percha, pointed at the ends, and each of the cylinders having projecting flanges furnished with eyelet holes, through which the several cylinders are lashed together. Each cylinder is composed of 8 thicknesses of the canvas, its flanges, by doubling and lapping of the edges, of four. For rowing, three light boards or stretchers can be placed above the whole. The very great buoyancy of this raft was shown in trials in which every available foot of room upon it was crowded with sailors standing closely together; the raft showed no sign of sinking under such a burden; and when but ordinarily loaded it can be rapidly propelled by oars or sails.

*The Second and Third Class Monitors.*—In January, 1863, there were building seven new Monitor batteries of 1,084 tons burden, and to

be known as those of the second class; three of these, the Mahopac, Manhattan, and Tecumseh, at Jersey City; two, the Catawba and Tippecanoe, at Cincinnati; the Canonicus at Boston, and the Manayunk at Booneville, Ky. These are to have each one turret, and carry within this 2 15-inch guns. Thus, the weight of their battery alone will (as in case of some of the first-class Monitors also) be about 50 tons, and they will discharge at once 900 lbs. of iron—a weight quite equal to that of the whole broadside of an old-fashioned war vessel. The armor of these vessels is to be 9 inches of plating, their turrets and pilothouses 11 inches thick, the increase in weight being allowed by the fact that they are to be of 18 inches deeper draught than the first-class Monitors. Of the third-class Monitors, are the Tonawanda, building at Philadelphia, the Monadnock, at Boston, the Miantonomah at Brooklyn, and the Agamenticus, at Portsmouth. These are each to be of 1,564 tons burden, and to carry 4 guns. Their armor will also be very thick, and the intention is to make them of unusual strength.

The Onondaga, built at New York, is of 1,250 tons burden, and carries 4 guns. This also, known as the Quintard battery, is a modification of the Ericsson pattern, having 2 turrets, length 226 ft., breadth 48 ft., depth of hold 18 ft., and the construction of which is expected to give unusual buoyancy. She has two screw-propellers, for use in manœuvring, as in turning on her centre, &c.

*The Dictator and Puritan.*—These are two large batteries and rams, also of the Ericsson pattern, the former building at New York, the latter at Greenpoint, L. I. The former of them is to be 320, the latter 341 feet in length, and each of 50 ft. beam. The vertical sides are to be 6 ft. in depth, armored with plates and wrought-iron slabs to a thickness together of 10½ inches, this being backed with 4 ft. thickness of solid oak. The turrets, of which the Dictator has one, the Puritan two, are to be absolutely invulnerable to the 450-lb. shot of 15-inch guns, and for this purpose to be of 15 inches thickness, the outer 6 inches of plates, then 5-inch slabs, and within these 4 inches of plates. The propulsive power will also be unusually great; each ship having two engines, with cylinders of 100 inches diameter and 4 ft. stroke. The modified Martin's boilers employed are to have 35,000 ft. of heating surface, with 1,180 ft. of grate surface. The propellers are Ericsson's, 21½ ft. in diameter, and of 32 ft. pitch. The guaranteed speed is 16 knots, or near 19 miles an hour. The armament is to consist of the most powerful wrought-iron guns that can be made. The plates and armor stringers meeting at the bow will form an iron wedge 21 inches thick at the base, and terminating in a nearly sharp edge; this wedge being sustained by the entire length and depth of the armor of the ship will constitute a ram of the utmost possible strength.

*The New Ironsides.*—This frigate, at the time of its launching the largest American iron-clad vessel afloat, is built somewhat upon the plan of the English Warrior. Her frame is of white oak, averaging in thickness at top of the sides 20 inches. Her armor is partial, extending from 4 feet below the water line upward to the spar deck, and horizontally the length of that portion of the gun deck containing her armament (170 feet), besides a belt of 7 feet width at her water line, and running entirely around, thus leaving a part both at bow and stern unprotected. The bulkheads, however, at each end of the gunroom are bomb proof. The armor is of single plates, 4 inches in thickness. The ports, 8 on a side, are closed, each by means of 2 wrought-iron plates which fall together at the recoil of the gun. The total length of hull is 232 ft.; breadth of beam, 57 ft. 6 in.; depth of hold, 25 ft.; draught of water at deep load line, 15 ft.; tonnage by measurement, 2,486 tons; displacement, 4,120 tons; estimated weight of armor, 750 tons. The vessel is bark-rigged, with short bowsprit, and no jib boom. Besides 2 200-pounder Parrott rifled guns, and 4 24-pounder boat howitzers, she carries a proper battery of 16 11-inch Dahlgren guns, the united weight of which is 234,800 lbs., while they throw at one broadside a weight of metal, shell, equal to 1,100 lbs., or solid shot, equal to 1,600 lbs. There are 2 horizontal direct-acting engines, diameter of cylinder 50 inches, stroke 30 inches, with surface condensers of 3,000 sq. ft. condensing surface; and, to supply these, 4 horizontal tubular boilers, with a heating surface of 8,450 square ft.; the estimated consumption of coal in 24 hours being 48 tons 840 lbs. The propeller is a single composition screw, with 4 blades, diameter .18 ft., mean pitch 16 ft., length 29 inches. With her masts (three in number) and spars in place, she can also carry quite a press of sail. Her bow is fitted with a heavy ram, securely fastened. From a circular pilothouse upon the spar deck the commanding officer communicates directly with the gun deck, and with the helmsman below. A defect of this ship is said to be in want of speed. In the attack on the forts at Charleston, in moving against the tide, she refused to obey her rudder, becoming quite unmanageable. Although she remained at about the longest range named above from Fort Sumter, and did not long present her side, so as to receive the enemy's shot direct, it is stated that some of the thick plates composing her armor were cracked.

*The Galena.*—This, one of the earliest completed of American iron-clad vessels, was built by Messrs. Mason and Fish, at Mystic, Conn., after designs by Mr. Julius Patterson. Her length is 208 ft., breadth of beam 36 ft., depth 12 ft. 6 in.; she is of 1,000 tons burden, and pierced for 18 guns. Her hull is of the best white oak, strapped with iron; and her sides, above water, slope inward at an angle of

about 30°. Her armor is applied in the form of iron bars, 24 ft. in length and 3 inches in width, these successively overlapping each other by  $\frac{1}{2}$  part of their width, and fastened to the wooden frame by screw bolts; while over this is an additional plating of 1-inch iron, also secured with like bolts. The gun deck is about 7 ft. in height, and has ports for 18 guns. The upper or spar deck is covered with thin plate iron, but said to be gun proof. The ports are closed by large pendulum shutters, which part in the middle, so that only the muzzles of the guns need protrude, and the gunners are comparatively safe. The round pilothouse has 5 inches thickness of plating. The armament consists of 11-inch guns and 100-pdr. rifles. In the combat with Fort Darling, on the James river, the plating of the Galena did not successfully resist a well-directed fire of large solid shot.

*The Roanoke.*—This vessel was originally a double-decked war frigate, and with the Merrimac also, one of a class of 5 steam frigates built in 1855. Having proved singularly unfortunate and expensive in her original trim, she was, by order of the Government, in 1862, razeed or cut down flush with her gun deck, preparatory to plating, the object being to convert her into a powerful iron clad, exposing but little of her hull above water to an enemy's fire. This vessel was armored, and received her additional engines, at the Novelty Iron Works, New York; her armor, consisting, like that of the Ironsides, of single or solid iron plates, in this case mainly of 4 $\frac{1}{2}$  inches thickness, having been forged at the "Franklin Forge" of Messrs. Tugnot, Dally & Co., of the same place. The plating, backed with 30 inches of oak, extends 4 ft. below the water line, and the whole length of the hull. The deck is covered with  $\frac{3}{4}$ -inch plates, placed one upon the other, so as to break joint where the edges meet; the joints come neatly together, but with a small space left to allow of expansion and the natural working of the ship. The plates are secured by countersunk bolts to the deck beneath. Over the hatch surrounding the smoke pipe where it issues from the deck, is a heavy grating of wrought iron, 1 inch thick by 7 inches deep, so that projectiles striking this must glance off without injury. The form of hull is that of sea-going vessels generally, and the deck will be without guards. The portion of the rudder post usually exposed will be covered by a strong wrought-iron hood, which will also protect the propeller from shot. There are three revolving turrets, of the new Monitor dimensions and pattern—11 thicknesses of 1-inch plate—and each pierced for two guns; two of these being forward, and one abaft the centre. The parts of the deck over which the turrets are severally placed are strengthened with circles of oak timber beneath, nearly 12×12 inches, these, again, being supported at regular intervals by stanchions of like dimensions. Each central turret

shaft rests on an immense cast-iron step, provided with a wrought-iron key, and a composition seat or base upon which this is to advance: the key being driven, the ways on which the turret revolves are thus relieved of a portion of its weight. Besides the blowing engines, and the auxiliary ones for moving the turret, &c., the vessel is propelled by the engines used in her when a wooden frigate—2 trunk engines, with 80-inch cylinders, and 36 to 42 inches stroke; the whole are supplied with 4 Martin's boilers and a large auxiliary or donkey boiler. The battery of the Roanoke consists of—forward turret, 1 15-inch smooth-bore gun and 1 250-pdr. rifle gun; middle turret, 1 11-inch and 1 15-inch smooth-bore gun; after turret, 1 15-inch and 1 200-pdr. rifle gun. This is said to be the heaviest battery ever yet put together on a single ship.

The Roanoke's bow is also furnished with a powerful ram. To form this, the forward plates project some feet beyond the stem, and farthest at about the water line. At the extremity, a solid piece of iron is inserted and firmly secured between the plates projecting from the two sides; and the angular space between this and the bow proper is filled in with solid timbers firmly bolted together. The Roanoke, now armed, is said to be as yet the most impregnable and formidable vessel of the navy. She is expected about the 20th of April, 1863, to take her position off the Narrows, as the permanent guardship of New York harbor.

*The Keokuk.*—This vessel, also named, from Mr. C. W. Whitney, her constructor, Whitney's Battery, was built in New York. The Keokuk is a two-turret ram, length 159 ft. 6 in., breadth 36 ft., depth of hold 13 ft. 6 in., draught 9 ft. Her hull is of  $\frac{1}{2}$ -inch rolled plates, the sides, above the water, sloping in at an angle of 87°, to prevent a square hit by the enemy's shot. The sloping sides, and the deck higher at the middle of its length, in this and a few other iron-clads of similar form above water, have gained for them the name of "turtles." Without going into all details of construction, it may be said that the peculiarity of the Keokuk's side armor consists in its being formed of alternating bars of iron and strips of yellow pine, each 4 inches thick by 1 wide, over the whole of which there are applied 2 continuous  $\frac{1}{2}$ -inch plates: it is claimed that this arrangement will give the strength of 5 $\frac{1}{2}$  inches of iron, without its full weight. The turrets do not revolve. Each is to contain an 11-inch gun, which is to be turned, as required, to different portholes. The turret armor is constructed like that of the sides, its total thickness being 5 $\frac{1}{2}$  inches; but the turrets, also, are sloping, being 20 ft. in diameter at base, 8 ft. 8 inches high, and 14 feet at top. A strongly-made ram, 10 ft. broad at the hull, 3 $\frac{1}{2}$  inches thick at the front and foot, and 5 feet long, projects from the bow. By means of bulkheads, water-tight compartments are formed within. These can be filled in 15 minutes

when it is desirable to depress the vessel in the water during an action, and emptied again by the pumps in 40 minutes. The Keokuk has two engines, each of 250 horse power, and two propeller screws, by means of which she can be manœuvred with great facility.—In the action at Charleston, occurring since the above was prepared, the Keokuk was struck by 90 shots: of these, 5 went through the after turret, 8 through the forward one, 7 through the smokestack, and several through the side armor, some near the water line. One Whitworth steel-pointed shot remained sticking in the wall of the after turret. The vessel sank the next morning, and was to be blown up.

*The Dunderberg.*—This, intended to be a highly impregnable and, in all respects, formidable iron-clad war vessel, is now building, after plans designed by Mr. W. H. Webb, and at his shipyard, New York. Her extreme length will be 378 ft., breadth 68 ft., depth of hold from the main deck 23 ft., tonnage 7,000, and she will be propelled by engines of 5,000 horse-power. The bow of this vessel, for a length of 56 ft., will be a solid mass of timber, and the frame and decks, in fact, the remainder of the hull throughout, will be constructed of an almost incredible weight of timber of the largest size, and braced within with iron bars diagonally crossing each other, of dimensions of 6 by  $\frac{1}{4}$  inches. The sides proper of the vessel, 2 ft. thick, are strengthened by an additional 2 ft. of timbers without. Before applying the armor, a projecting angle or "hip" is built on over the 4 feet of wood already mentioned, and entirely round the vessel, the greatest thickness occurring at the level of the main deck, and being there 7 ft. in all: from this level the hip slopes in at an angle of 58° with the vertical, until it terminates at the sides, about 6 ft. below water line. This sloping portion is completely coved with armor, of course set at the angle just named. Upon the main deck, for 170 ft. in the middle part of the vessel's length, a casemate of long octagonal form is built up, its sides sloping upward and inward at an angle of 47°. This, so far as it extends along the deck at the sides, forms a single angle with the slope of the sides below; and it rises by its entire height—7 ft. 6 in. in the clear—above the level of the deck at bow and stern. The sides and ends of this casemate are plated in the same manner as the sides of the hull, with  $\frac{1}{4}$ -inch solid plates. The deck plating and that upon the casemate roof is of  $\frac{1}{2}$ -inch plates. The total weight of armor will be about 1,200 tons. The main deck, and so the hip, is at 6 ft. above the water line. Upon the casemate roof will be erected two revolving turrets of great strength, and each to contain two guns of the heaviest caliber. There will also be at least 10 large guns in the casemate, the port sills being 8 ft. above the water line. There will be two rudders, so that in case one becomes disabled the other can be used; and both the rudders, along

with the immense propeller screw, will be protected by a strongly built overhang at the stern, its length about 17 ft., its width on either side of the propeller shaft, 12 ft., while, as a further protection, the sides of the overhang also curve or project downward. The solid bow, with its plating, will constitute the vessel a very powerful ram, the destructive force of which will be greatly augmented by the high speed, of 15 knots an hour, she is intended to possess; while, on the other hand, the hip will afford protection by first receiving the shock of a ram that may attempt to run her down. The Dunderberg is expected to be a highly efficient sea-going vessel. She will, probably, not be completed until about the beginning of the year 1864.

The Italian iron-clad frigates, *Re d'Italia* and *Clotilda*—the first-named already built and the last in process of construction—are also built by Mr. Webb, and at his shipyard. The *Re d'Italia*, now being armored with 4½-inch plates at the Novelty Iron Works, is a 40-gun propeller frigate, 294 feet long, and furnished with a ram. Five other Italian iron-clad frigates are building in France and England.

*The Benton, Gunboat.*—This is one of the fleet of gunboats hastily improvised for service upon the Mississippi and its affluents, in the early period of the war. She was constructed of two hulls joined side by side,—length 186 ft., total breadth 74 ft.—these hulls being sealed up between with 4-inch oak plank. The entire upper part of the hull, to several feet below water line, was then plated with ½-inch iron, securely bolted on. The *Benton* draws 4 ft. of water, and, besides having a bomb-proof bow, she is divided into 40 water-tight compartments, so that if her bow were shot away she would still float, and her gunners and men would be protected as before. The wheels are between the two single hulls, toward the stern, the wheel houses being, for ordinary missiles, shot proof. The sides, above water, slope inward at an angle of 45°. Her armament consists of 18 8 and 9-inch guns. In operations on the Western rivers, this and other gunboats of its class have, in a general way, performed satisfactorily, their fire being very efficient, and themselves, in but rare instances, thus far, disabled or sunk.

*The Essex, Gunboat.*—This iron-clad, which has figured quite conspicuously in river operations at the West, has a length of 205 ft., beam 60 ft., depth of hold 4 ft. 6 in. Her hull is nearly submerged, and her casemates have the unusual height of 17 ft. 6 in. The wood-work of her forward casemate is 39 in. thick; of the side casemates, 16 in., and of the pilothouse 18 in. thick. Over all these parts is a continuous layer of rubber, 1 inch thick. The iron plating bolted on over this is, upon the forward casemate and pilothouse, 1½ inches thick, that upon the side casemates ¾ inch thick. This vessel is also divided into 40 water-tight compartments, and upon her sides

are hips, or false sides, intended first to receive and break the blow of an enemy's ram. Her armament consists of 3 9-inch Dahlgren guns, 1 10-inch shell gun, 2 50-pdr. rifles, 1 long 32-pdr., and 1 24-pdr. boat howitzer.

*The Tuscumbia, Gunboat.*—This vessel, recently completed, is one of the largest of the Western fleet. Her length is 182 feet, beam 70 feet, depth of hold 8 feet, draught, when laden, 5½ ft., tonnage 980. The sides of this vessel are plated with 3-inch, and the deck with 1-inch wrought iron; the plates over the batteries or gun rooms will be 6 inches thick forward, and 4 aft. Her timbers are very strong, her build staunch, and outfit complete. A bulwark of iron, loop-holed for musketry, is placed around her guards. Her engines and machinery were made by Messrs. McCord & Co., St. Louis. The main engines, two in number, with 80-inch cylinders, of 6 ft. stroke, impel 2 powerful side wheels; while 2 other engines, with 20-inch cylinders and 20-inch stroke, work the two screws. Her armament is 3 11-inch Dahlgren guns, in battery, forward, and 2 100-pdr. rifled guns, in battery, aft. The magazines, or the hold, can, by the pumps, be completely flooded in a very brief time; while, as an addition to her armament, she has an apparatus for throwing, to a distance of 200 ft., a stream of scalding water.

*Other Gunboats and Rams.*—Certain iron-clads building at Pittsburg will have a length of 175 ft., beam 50 ft., depth of hold 7 ft.; the bottoms will be flat, the hull rising considerably out of water will present somewhat the form of a coal barge, though with sides less vertical, and greater sharpness toward the bow. The hull will be plated with 4-inch iron to 2 ft. below the water line. There will be 1 turret, its sides of 6 inches of plates. Each boat will be propelled by 4 engines, and will carry 2 large guns, her draught, loaded, being about 5 ft. These boats are intended solely for river service.

The *Indianola* is one of a new class, of gunboat and ram combined, intended for river service, and to have a light draught and high speed. Her wooden sides are 3 ft. thick, and her armor, over this, three inches of iron. The wheel, wheel house, and roof are bomb proof. The *Choctaw*, in many respects of similar construction, though of different form above water, will carry a heavy armament, and, with her high speed, will constitute a formidable craft.

*Recent English and French Armored Vessels.*—The French *navires cuirassés* thus far completed having, with the exception of the iron frigate *La Couronne*, wooden hulls over which the armor is applied, are like some of the American armored vessels correctly described as being "iron clad;" but a large proportion of the English vessels of the class under consideration being really iron ships with armor in addition, these are more properly described as "armored

iron," than as iron-clad vessels. In fact, a strict classification of the new vessels, based on materials employed and mode of combination in the construction of their hulls, has not yet been attempted; and while the (American) Roanoke and Dunderberg are strictly iron-clad vessels, in the Keokuk and some others, the character of hull is more nearly or exactly entitled to the description of "composite."

The only English counterparts, thus far, of the Warrior (described last year), are the Black Prince, also of 6,039 tons, and the Defence and Resistance, each of 3,668 tons burden. Their armor is, briefly, that of the sides only through about one half the length amidships, and from the upper deck to 5 ft. below the water line. In the Achilles, also of 6,039 tons, the same extent of armor is applied, along with the important addition of a belt of armor extended, for a space reaching a little above and below the load water line, entirely about the remaining portions at bow and stern; the purpose of this being to guard against the unfavorable accident of penetration "between wind and water." The Defence and Resistance carry each 14 casemate guns: their speed is slow. The Achilles has a casemate 200 ft. long, carrying 26 guns. The Northumberland, Minotaur, and Agincourt, each of 6,621 tons, and 390 ft. length, are to be protected over their iron shell, from stem to stern and from the upper deck to 5 ft. below water line, with a 9-inch wood backing and 5½ inches of armor, forming a casemate the whole length of the vessel, and carrying 40 broadside guns. All these are iron ships. The Prince Consort, Royal Oak, Royal Alfred, Ocean Triumph, Caledonia, each of 4,045 tons, and 277 ft. long, are wooden frigates previously in part constructed, and now being converted into iron clads; the extent of their armor will be the same as in the preceding (Northumberland) class, and their armament 32 68-pdrs. The Hector and Valiant, each of 4,063 tons, and 275 ft. long, and armored to the same extent, with the singular deficiency of a short distance at the water line near the bow and stern, will carry each 30 casemate guns. It may be added that many, if not all, of the vessels here described will carry in addition 2 or more Armstrong swivel guns, fore and aft.

The vessels of the three last-named classes are thus very heavily laden with armor; and to avoid this condition, it appears, Mr. E. J. Reed, Secretary of the Institution of Naval Architects, was first to suggest the plan of confining the armor to a short casemate amidships, with shot-proof bulkheads at its terminations fore and aft, and with this additionally a belt of armor a few feet wide carried round the remainder of the vessel at the water line. The ships recently, if not now, building expressly upon his plans, are the Enterprise and Favorite; the former of 990 tons, 180 ft. long, with four guns; the latter of 2,168 tons, 220 ft. long, with 8 guns. In the Enterprise, the hull below

the base of the central battery is of wood, but protected by plating with iron the deck situated at level of the top of the water-line belt of armor. The remaining upper works of the ship are of iron; while from the square central armored portion or tower the guns can be fired both athwartships, and fore and aft. Of the Favorite, the entire hull is of wood; and to protect it from being fired by shells, the portion of the sides above the armor belt and before and abaft the central battery are plated, but more thinly, with iron.

Besides the English vessels now described, there are three or more classes furnished with Capt. Coles' revolving "shields" or "cupolas," which correspond in purpose with the turrets of our iron-clad vessels, with the peculiarity, however, that (like those of the Dunderberg) they have a sloping sides. The Royal Sovereign, three-decked line-of-battle ship, cut down to her lower deck, and completely plated with iron, her length being 380 ft., has 5 of these cupolas, each intended for 2 110-pdr. breech-loading Armstrong guns. The Prince Albert, also a razeed ship and of the same length, has 6 cupolas, each to receive two similar guns. These formidable batteries are intended for coast defence. The class of iron vessels carrying two of Coles' cupolas have a length of 175 ft., beam 42 ft., depth 24 ft., draught 17 ft. All the vessels with cupolas, though not as high out of water as the casemate vessels, still rise above the water line higher than do those of the Monitor classes. Like the American turret-carrying vessels, they have no masts, and a mainly clear deck. Very recently, Capt. Coles urges that vessels of this sort should be masted; and he has prepared a model of such a ship with 4 masts, having a lengthened hull, and with one shield removed. To obviate the objection arising from risk of shooting away rigging, he proposes to make the masts of iron tubes rigid enough to bear the strain of the canvas, when standing entirely alone, *i. e.*, without shrouds or stays.

Of French armored ships, the original *La Gloire* class, 4 in number, and built of wood, have a length of 255 ft., and are completely clad with 4½-inch solid armor. There are 10 other French vessels of similar construction but of somewhat larger dimensions. The Solferino and Magenta, also of wood, and about 270 ft. in length, are plated on the same general plan with the American New Ironsides, and the English Enterprise, namely, with a central battery or casemate amidships at which the plating extends from the upper deck to a few feet below the water line, and a belt of armor a few feet in width at this line about the rest of the ship. They will carry each 26 guns.

*The Manufacture and Application of Armor Plates.*—Since it is for the present admitted that the armor must possess qualities to be found only in a good wrought or malleable iron, its production has thus far been confined to the two modes of rolling and hammering.

The relative advantages of these two methods are still only in part decided. In this country opinion and practice have favored the making of thin plates by rolling, since in such plates homogeneity of structure and uniformity of strength are less likely in this way to be sacrificed, and the manufacture is much more rapid; while for thick plates, in order to secure close interlacing of the fibres and uniform tenacity, working under the hammer has been preferred. The thin rolled plates are formed from bar iron or blooms, produced in the usual manner. The blooms for the thick plates are usually produced from "scrap iron," selected, but of mixed description, piled in fagots of a convenient size, brought to a welding heat in a furnace, and reduced under the steam hammer to a solid mass. Several of these blooms are then laid in a pile, four or more layers deep, and successively crossing each other in length, conveyed in this condition into a large furnace in which they are again heated until the whole becomes highly malleable, and under the steam hammer are then welded into a portion of a plate; and additions are made in like manner to one end of this, until the material requisite for a single plate has been in this way united. The plate so produced can be of almost any size desired, and it is finally brought to more uniform condition and surface by one or more heatings followed by working under the hammer. The plates of the Roanoke, forged and built up in this way, were of a usual length of 12 to 15 ft., and width of about 8 ft., their thickness generally  $4\frac{1}{2}$  inches, and their weight 4,000-7,000 lbs. Such a plate is a sort of oblong plank of iron: other plates of irregular outline required for special parts of the ship's sides are shaped by appropriate machines.

These plates are next drilled for the bolts, and those requiring it are also bent to fit the part to which they are to be applied. By means of "templets," or fac similes, in thin board, marked with spots corresponding to the holes already bored in the wooden body, or drilled (as the case may be) in the parts of the iron hull upon which they are to be fastened, the successive courses of plates, numbered in their proper order, are then marked for the bolt-holes and drilled; after this the holes are usually "countersunk," in order that the bolt-head may enter so as to stand even with the outer surface. The plates are finally bent to the shape they may be required to have, by the action of powerful hydrostatic presses. The required curvature is readily given to the plates for upright turrets, by placing them one at a time between a curved bed upon the upper surface of the movable platform of the hydrostatic press, and a fixed frame of like curvature above, and forcing the plate upward until it is shaped between the two, as in a mould. These plates are, at different works, bent either cold or heated. The plates for the sides of the ship require to be bent to a great variety of curves, and the expense of preparing a corresponding

number of moulds is obviated by employing an upper and a lower "die," each consisting of a series of strong iron bars, these being severally capable of being raised or depressed, as required, and at either end, by the action of stout screws which fix their positions. Above the upper die, which is movable, is a heavy iron casting to give it weight, while the lower die is stationary. A templet, representing any required plate, being placed between the two dies, the upper and lower sets of bars have their ends raised or lowered by the screws, until each bar exactly fits upon its own part of the templet; and the upper die being then raised to some distance, and the templet removed, the plate, already heated to a highly soft and ductile condition, is placed upon the lower die; the upper being then let fall, the weight with which it is loaded suffices at once to bring the soft plate to the required shape; or any slight departure from this is corrected by tightening the bars, at points where it is requisite.

In England, the two modes of producing the single thick plates under the hammer, and by the rolls have each their advocates. The hammered plates of the Thames Iron Works are thus made: The best scrap iron being selected and cleaned, is piled, heated, hammered into a bloom, and then rolled into bars 6 inches broad by 1 thick; these bars are cut up, piled and again hammered into a slab; several of these slabs are laid upon each other, heated, and hammered into the form of part of a plate; and the process being repeated by like additions at the end of this, the requisite length of plate is gradually produced. In other cases the hammered plate is more simply produced by successively welding together lumps or masses of scrap iron, to the required length. It has been objected to such, and in a degree to all hammered thick plates, that the iron under this mode of working becomes hard and brittle, and must lack a continuous and uniform tenacity. To this it has been replied that in properly made hammered plates, though somewhat hardened, the iron does not lose its fibrous and tough character, that by the requisite annealing, as observations on drilling and bending the plates and experiments upon targets show, the toughness of the iron is preserved and perhaps improved by the working; while the solidity and freedom from blisters or other faults in the incorporation of the parts are greater with the hammered plates.

Messrs. Brown & Co., of Sheffield, among others, advocate and practise the making of the plates by rolling. The dimensions usually required for the frigates now building in England are—length 15-18 ft., width 2 ft. 6 in. to 8 ft. 10 in., thickness  $4\frac{1}{2}$  in. The weight of an unfinished plate of usual size, as it comes from the rolls, is 80-140 cwt.; a few inches being cut from the sides and ends, the weight of the finished plate ranges from 60 to 110 cwt. In the making of a 5-ton plate, bars of

iron are first rolled to 12 inches broad by 1 thick and sheared to 30 inches length; 5 of these are piled and rolled down to a rough slab; two such slabs are then welded and rolled down to a plate  $1\frac{1}{4}$  inches thick, which is sheared to 4 ft. square. Four such plates are then piled and rolled down to one of  $2\frac{1}{2}$  inches thickness, and 8 feet by 4; and, lastly, 4 of these plates are piled and rolled to form the entire plate. There are thus welded together, during their successive reduction in thickness, 160 thicknesses of plate. That blisters and imperfection of welding and of cohesion should occur in a plate so produced is inevitable, especially, on account of the difficulty of bringing so large a mass to a perfect welding heat throughout, during the final operation of rolling into one the 4 large plates, each of  $2\frac{1}{2}$  in. thickness; and this want of perfect incorporation is held to be a source of weakness, by reducing the thick plate, in some degree, to the condition of laminated armor composed of plates extremely thin. Some plates recently made in this way, however, and of 5 inches thickness, have been proved, by experiments upon them at Shoeburyness, to possess a very satisfactory degree of tenacity and strength.

The subject of the methods adopted in fastening the armor to the wooden or iron sides of the vessel, by means of bolts, screws, &c., is one of too much detail to be interesting to others than the ship-builder or artisan; and, besides, it is probably not in all cases fully made known. It is still a matter of much difficulty to fasten any armor securely enough to the actual hull of an iron ship through a considerable thickness of wood backing; and, again, to fasten thick plates strongly to either an iron or wooden hull without, at the same time, weakening the plate by the number or size of the bolt-holes. The attempts to render thick plates in effect continuous by tonguing and grooving appear to have been abandoned on account of their expense, as well as of the weakness of the union thus made. Different patents have lately been taken out, however, for modes of fastening, partially or wholly, of the character here referred to, and both in this country and in England; as well as others for providing the plates with flanges within, through which only the bolts requisite for fastening are to be passed. Plates may be fastened, to some extent, by bolts made to protrude only from the back, or by holding them between angle-irons; and it is believed that they may yet be strengthened at the joints by welding, in the manner lately employed with boiler joints, by moving along the part light furnaces, from which a jet of flame is blown upon it, and following up closely with hammers. In some of the target experiments, in which the thick armor plates were fastened by means of screw bolts, screwed up from the inside, the bolts broke off short at the nuts whenever the target was struck by heavy shot. This mode of fastening is to some extent

adopted in the Monitor turrets, and for the plates of the New Ironsides, in the former of which some bolts have been broken, in the way named. An easy remedy appears to offer itself in screwing up the bolts less tightly.

*The Aspects of the Armor Question meanwhile Changing.*—The aim of the preceding part of this article has been to show the more important steps by which the plan of armoring ships became gradually matured, and to present in brief the several modes of armoring that have been actually and in rapid succession resorted to up to the beginning of the year 1863. Still, the armor actually adopted constitutes only one side of the question, and this, in fact, the secondary one. For, so long as the power of ordnance can be yet further increased, the demand for increased capability of resistance on the part of the armor of ships grows in the same ratio; and just so long the issue between the two remains undecided. The struggle is, on one side, for positively irresistible artillery; on the other for absolutely invulnerable ships: will either of the two finally and completely distance its antagonist? and if so, which one? or will the two come ultimately again to a tolerable balance of chances, such as, some 50 years since, existed between wooden ships and broadsides of the largest round shot then in use? and, if this is to be the result, through what steps is it to be reached?

It is a well-known fact that while, for the past two years, iron-armored vessels of all dimensions, and in great numbers, have been hurriedly building on both sides of the Atlantic, during this very period, and also on both sides, the caliber and firing charge of cannon have been undergoing a marked increase, and which, moreover, promises still to continue. Already shot and shell are safely and regularly thrown, which have powers of crushing and of penetration such as were not at all contemplated in the estimates of requisite strength that dictated the armor of *La Gloire*, the *Warrior*, the ordinary Monitors, the Ironsides, and their counterparts. The present phase of the armor question cannot be understood without a fair idea of the most recent advance in the capacities of heavy ordnance; and of the execution done by the projectiles thrown by it. While upon these points theoretical views must, still, to a certain extent, be accepted, much information may be drawn from the set experiments made in the way of firing upon targets; and, for the latter source, reliance must, as yet, chiefly be placed upon the English experiments, as the only ones very fully published. Some principles relating to the subjects of ordnance and projectiles must, of course, here be introduced as preliminaries.

*Destructive Power of Projectiles.*—The momentum, or quantity of motion, in a moving projectile is proportional to the product of its weight into its velocity; that is, *momentum* varies as  $W \times V$ . This is the measure of the



capacity the projectile has, if instantaneously stopped by some other body in any part of its flight, to put that other body in motion. Consequently, supposing a cannon ball in no degree to penetrate armor plating against which it is fired, but to be instantly and totally arrested at the surface, this momentum is also the measure of the shock or concussion the ball will give to the armor. The ball, having its motion extinguished, either the ship as a whole or the part struck must be proportionally moved; and, remembering that the most rigid sides of iron and wood will, still, bend, and may fracture, while it is the nature of inertia to prevent the communication of the motion, instantaneously, to the whole ship, it follows that the part struck, for a greater or less area, and to a greater or less extent, according to the conditions of the case, will move from before the projectile which it arrests. If this yielding be under a blow sufficiently great, the effect will be permanently to bend the plate, or to fracture it, perhaps to drive it into the wood backing, and to start or crush the latter. In this way the plates may be fractured, shattered or loosened, the bolts driven in, or the structure of the ship, at the part, racked or strained, and perhaps a leak produced. Now, it is important to remember (a point too often overlooked) that all these effects, *per se*, are due to, and measured simply by, momentum, and, hence, increased directly and simply by increasing the product of weight and velocity (not of weight and the *square* of velocity). Thus, if the two balls be of similar form, and could act by momentum alone, then, at short range, Sir Wm. Armstrong's 110-pounder, fired with 14 lbs. of powder, and with an initial velocity of 1,210 ft. per second, should have, to the common 68-pounder, fired with 16 lbs. of powder, at an initial velocity of 1,580 ft. per second, a damaging effect in the ratio of  $110 \times 1,210$  to  $68 \times 1,580$ ; or, nearly as 13 : 11.

But precisely to the extent that the material and structure of the ship's side combine to give rigidity and immobility to the part struck, so that, while the gradual operation of inertia will not allow the whole ship to recede, these qualities refuse to allow the part to yield through any considerable extent so as to be crushed in or fractured and recoil, it will then be true that one or both of two other results must follow, namely: the projectile must expend the quantity of force stored up in it in the way of compressing, flattening, or crushing its own mass, in the first case, perhaps rebounding, either whole or fractured, or else it must expend the same force in the way of overcoming the cohesion and resistance of the materials it strikes, and pushing or cutting its way into or through them. But this quantity of force or work stored in the moving ball is proportional to the product of its weight into the *square* of its velocity; that is, the *work* varies as  $W \times V^2$ . It is already evident, then, that the execution of a ball or shell in the way of punch-

ing or penetrating the armor, and generally the sides, of a ship, must also be in this ratio: it increases, so far as the mere force is concerned, as weight and square of velocity. Supposing, then, their entire energy to be expended in the way of penetration, the projectiles above named would be capable of damaging effect in the ratio of  $110 \times 1,210^2$  to  $68 \times 1,580^2$ ; or, nearly as 16 : 17; so that here, allowing for the Armstrong projectile the highest initial velocity claimed for it, the advantage is still on the side of the 68-pounder, with larger firing charge and higher velocity. The weights of projectiles of like form being, in general, as the products of their diameters and densities, it may be correctly said, also, that their punching or penetrative capacity will be as the products of the three factors, diameter, density, and velocity *square*.

Thus, projectiles can have two sorts of effect upon obstacles, say the armor or sides of a ship, namely, that of pushing or crushing away the part before them until their *motion* is consumed in imparting an equal motion; or, that of overcoming their own cohesion or that of the part struck; in the latter case driving or cutting into the part until the *work* stored up in them is in this way expended. But since, generally, under the instantaneous blow of a projectile the armor and side of the ship, in degree, both yield and refuse to yield, it follows that, in actual cases, the two kinds of effect will usually be mixed, though one or the other may predominate. It would appear, however, to follow that, other things equal, very large and heavy projectiles, thrown at a lower velocity, should be relatively more effective in the way of fracturing or shattering armor, and straining the general structure of the part, while shot or shell of less weight, from guns bearing a heavy charge of powder, and giving a high initial velocity, should be more effective in the way of penetrating the armor and sides, as where the object may be to cause a leak or to carry shells into the interior. This distinction, questioned by some authorities, and not always clearly drawn, appears, still, to be that more generally held as practically correct.

Sir Wm. Armstrong concludes that it is not by piercing small clean-cut holes with steel shot, that a ship is to be disabled or destroyed, but by knocking large ragged holes in the side, and rendering the interior untenable from splinters. Stating the case, however, in the most general way, it appears that the greatest amount of destructive effect will be produced by the guns which can give to the heaviest projectiles the greatest velocity; and this amounts to saying, in other words, those which with a given caliber and weight of projectile admit of being fired with the heaviest charge of powder. In spite of some assertions to the contrary, the opinion is now gaining ground that the superior execution of the new wrought-iron, hooped, or otherwise strengthened forms of ordnance, over

the usual cast-iron guns, is especially due to the increased charge—35 to 60 pounds, or more, of powder—of which their greater tenacity and strength admit. So far as smooth-bore guns admit of heavier charges than rifled, the former have also the advantage in this respect; but there are important differences in the behavior during flight of the two kinds of projectiles, that must also be considered. At short ranges, say, under 400–600 yards, the round shot of the smooth-bore gun still moves with somewhat nearly its initial velocity; but this it is rapidly losing, owing to the greater resistance it encounters from the air; and a little farther on it is outstripped by the rifled projectile, which at long ranges is thus the more effective. Admiral Dahlgren says, "The rifle shot has greater penetration than the round, but much less concussive power. . . . If, in battering an iron-clad, penetration only shall be the paramount consideration, and other effects merely incidental, the rifle cannon must be selected. But if the concussion and shattering of the plate and its backing be preferred, with such penetration as might be consequent thereon, then the heavy, swift, round projectile will supply the blow best adapted to such work. So long as the present mode of plating continues, there can be little doubt that it will be most effectively attacked by cracking and bending the iron, starting the bolts, stripping off the armor, and breaking away large portions of the wooden structure within." In respect to the form of the ends of shot, Prof. Fairbairn's experiments appear to prove that the penetrative power and effect of round-ended is twice as great as that of flat-ended projectiles.

The material of the shot has also an important bearing upon the nature of its effects. In striking armor or other rigid obstacle, hardened steel shot undergo less compression than any others, and their great tenacity renders them but little liable to fracture; hence, the work of which they are capable is, in higher degree than with other sorts, expended upon the opposing body. For round-ended shot, Prof. Fairbairn has found by experiments in punching plates, that when these are of steel, the dynamic resistance or work of which they are capable is more than three times that of like shot of cast iron. He concludes (in a paper read before the Brit. Assoc., 1862,) that the conditions apparently desirable in projectiles, in order that the greatest amount of work may be expended upon the armor plate, are: 1. Very high statical resistance to rupture by compression. In this respect, wrought iron and steel are both superior to cast iron. The statical resistance of steel is more than 3 times, and that of wrought iron more than twice, that of cast iron. Lead is inferior to all the other materials named. 2. Resistance to change of form under great pressure. In this, also, hardened steel is superior to wrought iron, and cast iron inferior to both these. Finally, the shot which would effect the greatest damage to

a plate would be one of adamant, incapable of change of form. Such a shot would yield up the whole of its *vis viva* to the plate. And experiments prove that the projectiles that approach nearest to this condition are the most effective. The much greater cost of steel shot has hitherto stood in the way of their adoption; but M. Bessemer appears to have assured Fairbairn that he could produce steel shot at little more than the cost of those of cast iron. Dahlgren asserts that the actual damaging effect of cast-iron is greater than that of wrought-iron shot, in that, while the latter is merely flattened or crushed by impact, and tends then to lodge in the plating, the former, though it breaks, is more apt to pass completely through, making a larger hole, and badly cracking the plate.

In this country, guns for throwing very heavy shot—450–476 lbs. solid—are in successful use; and one at least for throwing a 1000-lb. ball is already constructed and in readiness. But the most recent change in the direction of efficiency of shot, appears to be in the adoption of the plan, which had already come into favor in England, of larger charges of powder. The maximum charge, up to this time, has been 35 lbs. of powder. The Government, it is stated, has now ordered cannon, preparations for fabricating which are already in progress, which will bear the explosion of 60, and possibly of 70 lbs. of powder; and it is believed that the 450-lb. shot thrown with such a charge, will prove the most destructive missile thus far ever employed. Admiral Dahlgren, also, in his recent report, states as the result of repeated and severe tests of their capacity in this particular, that the 9-inch and 11-inch cast-iron guns, until recently the largest in use, bear continued firing with charges much greater than those for which they were intended; the 9-inch one half greater, and the 11-inch with double the original weight of powder.

*Resistance of Iron Plates.*—The law admitted to hold generally true in respect to the resistance of plates of any given kind of iron to punching or fracture, is, that such resistance is directly proportional to the sheared or fractured area—the total length and breadth of metal, throughout which the cohesion of the particles is overcome,—and hence, that it is as the depth and diameter of a hole cut in the plate, or as the total length and depth of the fracture produced in it.

The question as to the relation the strength and resistance of a single homogeneous plate bear to its thickness, appears not yet to be decided. Experiments early made at Manchester appeared to show that the resistance varies directly and simply as the thickness, so that a plate twice as thick as another has only twice its power of resisting impact. During the last year, however, at Shoeburyness, a target of 5-8 inch boiler plates, with a 1½-inch plate in front, the whole held together by alternate rivets and screws 8 inches apart, and having a thickness

of 8 inches, was completely penetrated by the 8-inch 68-pdr. smooth-bore gun and the 100-pdr. rifle, at 200 yds., though at like range these guns have not greatly injured the best 4½-inch solid plates; and a 10-inch target similarly constructed was much bulged and broken at the back by the same guns. From these and other data, Fairbairn deduces a conclusion in common with that now generally held in England and France—and made in those countries the leading argument in favor of armoring with single thick plates—namely, that up to a certain limit, and which lies beyond the thickness of any plates yet adopted, the resistance of the plate to shot increases very nearly as the square of the thickness; so that with thicknesses of 1, 2, 3, etc., the capacities of resistance are as, 1, 4, 9, etc.; and that a single 4½-inch plate has practically about twice the strength of two 2½-inch plates laid together, though the latter give the same total depth of metal. In the experiments of Mr. Stevens in 1854, however, a 10-inch 125-pdr. round shot, with 10 lbs. of powder, and having about the same penetrating power with either of those above named, only slightly indented and did not break a 6½-inch target composed of plates of similar thickness to those made use of in the English experiments. It is stated that the experiments, individual and official, on the subject in this country concur in showing even a superior resistance in laminated armor. The comparatively smaller firing charge, and lower velocity of ball which have here been hitherto the rule, may serve in part to explain away the value of these results. In explanation of the assumed superior resistance of single thick plates—though the fact makes against them when penetration actually occurs—it has been urged that in punching such a plate with a projectile, the hole made is conical, about the size of the ball in front, and much larger at back, while the hole made through laminated armor is cylindrical; so that, in the former the sheared or fractured area must be much greater.

Besides the area of fracture, however, and the absolute thickness of single or partial plates, many other circumstances must enter to decide in a given case the relative capacities of the ball and the armor. Among these are: differences in the qualities of the metal of the ball and of the armor, as in case of the best hardened steel shot striking armor which has either too great brittleness or too great softness; the presence or absence of uniform cohesion and strength throughout the thickness of each single or partial plate, depending on the manner in which it has been manufactured; the necessity of joints and bolts or rivets in the armor—almost always elements of weakness at the points where they occur; and the extent to which the mode of applying and fastening the plates is made to prevent or compensate such weakness. The latest conclusions still appear to be to the effect that, for the most effective sort of plating, the three qualities requisite are: 1, that the

iron shall not be of a crystalline texture; 2, that it shall possess considerable ductility and the greatest possible tenacity; 3, that, to these ends, it shall be a very fibrous iron. To these qualities it will probably have to be added that, fourthly, in order to effectual resistance to the almost unfracturable shot of metal having the utmost tenacity and hardness, the possession also on the part of the plate of the utmost hardness compatible with the three qualities above named, is indispensable. Beside the use of Franklinite, presently to be referred to, it has been suggested that possibly a very low Bessemer steel, or iron, as likely to supply all the needful conditions, may yet be cheaply adapted to the making of armor plates.

Mr. A. L. Holley, after remarking that our information in respect to the relative strength of single and laminated armor is still too incomplete to warrant a conclusion, adds: "It is probable that the heavy English machinery produces better-worked thick plates than have been tested in America, and that American iron, which is well worked in the thin plate used for laminated armor, is better than English iron; while the comparatively high velocities of shot used in England are more trying to thin plates, and the comparatively heavy shot in America prove most destructive to solid plates. So that there is as yet no common ground of comparison [between the results obtained in the practice of the two countries]." In respect to joints and fastening, Fairbairn was led by tests made with a view to this particular subject, to the result that, taking the cohesive strength of a given plate at 100, the strength of an ordinary double-riveted joint is about 70, and that of a single-riveted joint not more than 56.

It appears very recently to have occurred to the English naval authorities that the bending of the thick iron plates to fit the ship's sides, as has so far been practised in case of all or nearly all their armored vessels, must render the plates so bent more vulnerable. Very few of the American armored vessels have been constructed with bent plates; among such are at least the Roanoke and the Onondaga. It would seem that the greatest strength, in this respect, would be secured by forging the plates as nearly to the required shape as possible, and then fitting the sides or backing to the plates, rather than these to the surface they rest upon.

*The Recent Experiments with Modern Heavy Ordnance.*—In October, 1861, a target 20 feet long by 10 feet wide, and representing the side of the Warrior—4½ inches of solid iron on 18 inches of teak backing, with an inner lining of ½-inch wrought iron—was fired on at 200 yards' distance, at Shoeburyness, during the principal part of two days, with solid 68-pounders, 110-pounders, and 200-pounders, both singly, and also in salvos of 3, 4, and 6 guns at a time, concentrated on white spots painted on the supposedly weaker parts of the target. The missiles simply rebounded, or broke and flew

off in fragments; and though they battered the plates and heated them in parts almost red hot, yet none of them passed through, nor, until the final salvo of 6 100-lb. balls, fired with 16 lbs. of powder each, and aimed on a single spot to one side, did they even fracture the outer plating: the effect of this last fire, however, was to make a gap in the outer plate 15 inches long and its whole depth, loosening some of the bolts, but not really disturbing the backing or inner plate. The conclusion for the time was, that the Warrior style of armor was practically invulnerable to the ordnance at the time in use.

But during the whole course of the experiments at Shoeburyness, it was observed that the smooth-bore 68-pdrs., fired with more powder, left their mark in deeper dints in the plate than did the Armstrong rifled 110-pdrs.—a fact the cause of which has been shown in the section on the *Power of Projectiles*. This led to or strengthened a conviction in the minds of those interested in the making of ordnance, that large wrought-iron guns, strong enough to bear heavy firing charges, would at close range penetrate the armor which came so triumphantly out of the previous tests. Sir Wm. Armstrong accordingly had a gun fabricated for elongated 300-lb. shot, its bore 10½ inches and greatest diameter 38 inches, and which, not having been rifled, was fired (April 8, 1862) with a 156-lb. round shot and 40 lbs. of powder, against the target above described, or a similar one: the first shot crushed the outer plate at the point struck into "crumbs" of metal, splintered and mashed the teak backing, and badly sprung the inner plate; and the second, striking near, aggravated the damage and its extent. The charge was then increased to 50 lbs., and the third and fourth shots each went, at different points, completely through the outer plate, backing, and lining, burying themselves in the timbers supporting the target. A change of opinion in reference to the practical invulnerability of the Warrior armor, at least for a square hit at short range, of course set in; and although for a time it was urged by some that the actual damage to the target had been overstated, and in spite of the fact, that after some 160 discharges the Armstrong gun burst, showing that the charges used were too much for the metal and construction, the more decisive experiments, soon afterward made, completed the overthrow of the confidence previously entertained on the side of armor defence.

The experiments in firing solid shot and shell upon targets were renewed in August, 1862; and upon an occasion on which members of a select committee of the Government on iron plates and ordnance were present, the new Horsfall wrought-iron smooth-bore gun, caliber 18 inches, weight 22 tons, and carrying a 286-lb. solid ball, as well as other pieces, was tried. The standard Warrior style of target being used, range 200 yds., and charge 75 lbs. of powder, the first shot smashed through the

entire target, striking out a huge hole more than 2 ft. in diameter, cracking the surrounding iron in all directions, and unfitting the target for further experiments. The gun appeared to be in no way strained or injured by the fire.

In the experiments previous to this time, the shells fired against armor of moderate thickness had been broken; and it had been held that vessels covered with 2½-inch plates were shell-proof. A Whitworth rifled breech-loading 12-pounder field gun of 4-inch bore was on this occasion loaded first with a flat-fronted solid steel shot, and fired at 100 yds. upon plates of 2 and 2½ inches: in both cases the shot cut their way clear through the plates. The same gun was then loaded with a flat-fronted steel shell, containing 6 oz. of powder, and fired with a charge of 80 oz.: no fuze was employed, but, as expected, the concussion ignited the bursting charge; one such shell passed through a 2-inch plate and 12-inch oak backing, another pierced the plate and burst in the backing, shattering it to pieces. A Whitworth 70-pdr. naval gun was then tried against a target of 4-inch plating on 9 inches of oak, attached to another frame of four inches of oak, lined finally with a 2-inch iron plate, the space between the two frames being 80 inches. A 70-lb. flat-fronted steel shell, fired with 12 lbs. of powder, at 200 yds., was driven clean through the first plate and backing, reached and fractured the 2-inch plate, and then burst, shattering the target. Prof. Fairbairn concludes that, against such weapons as those employed in these experiments, no American gun-boat [query, iron-clad vessel?] is proof; but that, with Whitworth's hardened steel shells, such vessels could be destroyed at 1,500–2,000 yards. It was observed in these experiments that the Whitworth flat-fronted steel projectiles cut clean holes through the outer plates, without fracturing them as did the ball from the Horsfall gun. It was believed by those present at the trials, that the latter would have gone through a plate 6 inches in thickness.

Sept. 25, 1862, experiments were made with the same Horsfall gun, and an Armstrong 120-pdr., rifled on Whitworth's plan, the range now being 800 yards for the former (18-inch) gun, and 600 yards for the latter (7-inch). The target was 21 feet long, 15 feet high, of the Warrior pattern, already given, and strengthened within by a framing of massive angle irons, set 18 inches apart. The Horsfall gun was fired 14 times with solid shot of 275 lbs., and a 75-lb. charge, at least two of the shot striking. One, a ricochet, bounded from 40 yards in front, smashed through the armor, making a great hole, shattering the teak and fracturing the lining, but not passing through; another, striking the upper corner of the target, made a huge fracture, breaking out several great pieces from the outer plate. The Whitworth rifle, with a firing charge of 28 lbs., sent a solid hexag-

onal flat-fronted shot, 18½ inches long, weight 180 lbs., through the armor into the wood, shattering one of the angle irons, but not going through. With the same gun, a shell of "homogeneous metal" (low cast steel), 17 inches in length, holding 8½ lbs. of powder, weighing 180 lbs., and fired with a 25-lb. charge, was sent clean through the 4½-inch armor plate and the wood backing, exploding as it struck the inner plate, and tearing the latter into fragments. The solid shot and shell from this gun made clean 8-inch holes through the armor; and their velocity at the moment of impact was ascertained to be 1,284 ft. per second. Thus, the standard English system of armor was proved to be completely vulnerable even to shells; but, on the other hand, the result appeared to be due to the high firing charge and velocity secured by the Horshall and Whitworth guns, and to the use with the latter of the hardened steel shot and shell; so that the English authorities consoled themselves with the conclusion that, in comparison, the French navy rifle guns, and the American cast-iron Dahlgren guns are "useless against iron sides." It appears that, still more recently, the Whitworth rifle, last referred to, has thrown a 150-lb. shell, holding 5 lbs. bursting charge, and fired with 27 lbs. of powder, completely through a 5½-inch armor plate and 9 inches of backing, the shell exploding in the space beyond, representing the hold of the ship!

In respect to recent experiments in the United States, as already implied, although these have been now for a long time in progress at Washington, as well as, perhaps, elsewhere, and, it appears, on no limited scale, very little connected with the results has yet been made public. It is said that the hollow 875-lb. shot of the 15-inch guns, their walls 8 inches in thickness, thrown against 10½-inch laminated armor, backed with 18 inches of oak, were broken without doing serious damage to the armor. Admiral Dahlgren speaks of a new class of gun—caliber not positively given, though probably 15 inches—which, at 200 yards, has sent its shot, with ease, through 5½ inches of iron plates and 18 inches of oak backing.

*Practical Qualifications as to the Relative Efficiency of Guns and Armor.*—Even, however, the facts that the most powerful ordnance has sufficed to pierce and demolish fixed targets, under a fair fire on land, do not prove the actual (similar) armor of ships useless; and many qualifications of the results above found in reference to the resistance of plates and the power of projectiles must, in practice, come in on both sides—so many, in fact, that the actual trial of the two in naval engagements must finally decide these questions, and may decide them quite differently from any present anticipations. Prof. Fairbairn considers that the victory is now in favor of the guns, and that it may be difficult to con-

struct ships of sufficient power to prevent their destruction by entrance of shells. Again, the destructive effect of ordnance generally is greatest at short range, and on account of the limited number of guns usual in the new styles of armament, and the known resisting power of an antagonist's sides, as well as the difficulties of aiming at sea at a distant moving object, iron-clad warfare will probably be carried on as a rule at close quarters. Still there are many circumstances which will be availed of on each side to delay or avert a conclusive blow, until its own guns can be brought into play. Thus, in favor of the armor and ship (defence), there are the uncertainty of securing a square hit, even on vertical sides; the danger with large charges of bursting of the antagonist's guns, an accident but too much favored by the new charges of ¼ to ½ the weight of the ball; with certain styles of iron-clad, the limited number of the guns, and in proportion as these are of large size and heavy firing charge, the necessity of longer intervals—with 15-inch guns, not less than from 3 to 8 minutes—between the discharges; the relatively small chance, where a partial damage has been inflicted, of increasing or completing it by another shot upon the same point; and so on. It would for the present appear that the 20-inch 1,000-pdr. guns must be confined to use in forts, and from which their steady aim would enable them to tell with terrible effect on vessels even at a distance of 1,000 yds. or more; so that while they are obviously desirable for harbor defence, they are likely at the same time to be in the main or wholly excluded from naval conflicts.

On the other hand, in favor of the guns (attack), are found such facts as, that the practical thickness of armor and backing must always be confined within a small limit; that heavy armor on a ship's sides, more especially when far removed from the frame and proper walls of the hull by intervening thick wood backing, continually exerts a strain tending to break down the sides, and thus in effect coöperates with the racking blows of heavy projectiles; that an enemy's portholes are always exposed to the entrance of the most damaging missiles at the moment of being opened for firing; that the concentration, in partially protected vessels, of armor over casemates and at the water line, necessarily leaves some parts vulnerable, &c.; while to all these circumstances another arising from an entirely different source must be added; namely, that the targets used in the experiments made on land have unquestionably possessed a greater strength and resisting capacity (though this is perhaps less true of laminated armor), than is likely to be found in any section of an actually armored ship's side, which they are intended to represent.

*The Question of Inclined or of Vertical Armor.*—The principle of inclining the armor from the vertical, so as to favor the glancing of

shot, and save the plates from receiving the full force of the blow, appears to have been first proposed by Mr. Josiah Jones, of Liverpool. Among the experiments made to test the value of this plan, were those in England, in 1861, in which a  $3\frac{1}{2}$ -inch solid plate fixed at an angle of  $45^\circ$  was more injured by elongated 100-lb. shot, than a  $4\frac{1}{2}$ -inch solid plate in a vertical position, the two plates having the same backing and equal weights of metal in the same vertical height. In fact, the Iron Plate Committee have recently reported that with any practicable inclination from the upright—as much as  $52^\circ$ —it takes the same weight of iron to cover effectually with armor a certain length and height of side, whether this be inclined or upright. This is but another mode of expressing the conclusion arrived at by Mr. Stevens in this country, that a given thickness of iron measured on the line of fire, whether the plate be fixed in a vertical or an inclined position, offers about equal resistance to the average shot striking it. These general statements must, however, be to some extent qualified, both for the form of projectile and sort of gun, on one hand, and for the relative hardness of the armor surface, on the other. Elongated projectiles thrown from smooth-bore guns are notoriously uncertain of effect in a first oblique impact, and of direction after being from any cause once “ended over” or glanced. With projectiles of such form, rifling appears indispensable, in order to give persistency in direction of flight, and to keep them on end while cutting into armor. And in such case, especially if the shot be hardened and flat fronted, it is not glanced except by armor set at an angle with the horizon so small as to be impracticable, in view of its forbidding the proper accommodation and working of the guns, and rendering the hull deficient in stability and bearing; while, further, if the shot are glanced, and often in that case in fragments, they must prove so destructive to objects on deck as to render masts, rigging, and sails unavailable. Round shot, indeed, are likely to be glanced by armor set at an angle of about  $40^\circ$  or more with the vertical; and in experiments on the subject in this country, a  $6\frac{1}{2}$ -inch laminated target, vertical, was by a 125-lb. spherical shot indented about 4 times as deeply as  $6\frac{1}{2}$ -inch plate, also laminated, fixed at an angle of  $27\frac{1}{2}^\circ$ . Besides the disadvantages of inclined armor already named, are those of its greater expensiveness, the waste of room it occasions, and the fact that to a more direct fire from elevated guns, as those of shore batteries, its less actual thickness renders it quite vulnerable. In fact, in the United States comparatively few armored ships have been constructed with inclined armor, and in England the principle is regarded as abandoned. Since, on the part of the armor, a surface at once highly hard and tough must increase the tendency to glance shot, the use of the Franklinitic iron for surface plating may be

found to render a practicable inclination of greater value as a means of protection; and experiments with a view to this end are said to be in progress.

In the Exhibition of 1862, Mr. C. J. Richardson exhibited drawings of a modification of the inclined principle for the sides of ships. He proposes to apply the armor in the form of projecting conical shields, each shield having slightly curved projecting lips or bases; the forms being such as he believes will cause shot striking to be deflected in a direction back toward that from which they came. He makes the portholes either circular or oval, and continues the circular lip round them, so that shot glancing over the surface of the shield may be deflected from this also. Mr. J. W. Couchman, in a model of a floating battery, combined with vertical ports the sloping side between ports, as attic windows are formed in a sloping roof. The necessity of rendering the sides and roofs also of these ports shot-proof, would probably make the proposed armor enormously heavy.

*The Question of Kind of Armor, and of Backing.*—So far as the data upon which must be decided the question between the claims of laminated and of solid armor have yet been determined, those data have, it is believed, been in the main embodied in the foregoing parts of this article, and particularly in the section on *Resistance of Iron Plates*. Each method of plating has its own advantages, and its own defects; and while it is certain that the question of the relative value and desirableness of the two systems has not been decided either way, the final result may be in finding each of them the more eligible for particular sorts of vessel or kinds of service. Certain well-conducted experiments would seem to prove at least that, with the same thickness of iron, the solid armor throws off and keeps out a shot which may deeply indent or pass through the laminated. This might be quite conclusive, if penetration were alone the question; but such is by no means the case. While Admiral Dahlgren gives prominence to the fact that a very thick solid plate can scarcely be made equal in texture to the thinner ones, and remarks that, in every instance in which he has seen a solid plate pierced by shot, a separation of the metal at the welds has shown the imperfection of the union there formed, Mr. Holley regards the experiments as showing so great a difference, in simple and absolute resistance to shot, in favor of the solid iron, as to leave a large margin for possible defects in the quality of the latter. It appears quite certain that fracture is more likely to result in solid than in laminated armor, since in the latter the separate plates are more capable of yielding in virtue of their elasticity; and that, when caused, it is also more serious in the former. All thick plates are in proportion much more weakened by the necessary large bolt-holes through them than, owing to its mode of application, are the plates of laminated armor;

and with the solid plates, as their thickness is increased, this source of weakness will be aggravated in a degree in which it is not with armor of many thin plates. Thick plates impart no strength to the ship, nor do they help to strengthen each other, but in fact hang separately as so many loads on the ship's sides, constituting again by their weight a source of strain and weakness. Thus, the Duke of Somerset, in the House of Lords, in the early part of 1862, admitted, and the statement holds equally true of all English armored ships built up to this time, "We have not yet constructed a vessel in which the iron plating adds to or assists in constituting the strength of the vessel." "A series of thin plates," however, as Mr. Holley remarks, "breaking joints and bolted through the backing, not only fasten each other, but are in effect a continuous girder;" and in this way, they not only afford support to each other, but strengthen the entire hull at the same time. Meanwhile, laminated armor is both the cheaper and the more easily put on. On the side of solid plates, it has been urged that if the resistance practically does increase as the square of thickness, and 4½ and 5-inch plates are found to tax severely the powers of the best ordnance, then in plates of 8 inches thickness is probably to be found a positive protection against the most powerful guns that can be constructed. Supposing this could with such plates be the result, the facts already presented appear to throw doubts, if not upon the feasibility of constructing them of good quality throughout, at least on that of securely and satisfactorily applying them.

In respect to the use or disuse of a wood backing for the plates, it may be stated that while English opinion and practice decidedly favor the armoring only of iron ships—and this, in spite of the recent efforts of the Admiralty to get the surplus wood in the shipyards used up in a certain number of wooden hulls,—there are those interested in the subject in that country, who argue in favor of armoring with *iron on iron*, dispensing with the intermediate wood. Among the advocates of this plan has been Prof. Fairbairn, who urged that while a wood backing by its elasticity and yielding softened the blow of a projectile, this was done at the expense of the plate, since the latter would be more deflected and driven into the wood. But in all the firing upon the laminated armor of the Monitors which has yet taken place, no such result of a broad area of the plating being permanently bent and compressed into the backing has occurred. Fairbairn admits, however, that with iron on iron there is greater risk that the result of two or more heavy shot or of a well-concentrated fire might be not only to penetrate the plates, but also to break the ribs of the ship; and from results of the very latest experiments with the 300-pounder gun, he concludes that some softer and more compressible substance than iron between the armor and

sides is necessary, in order to deaden the blow; so that the wood backing cannot be dispensed with. This action in the way of distributing and softening the blow upon the hull and ribs of the vessel, as well as upon the armor, appears to be the true function of the wood backing, so that while it adds little to the real strength of armor, it adds greatly to the protection of the ship, and may be considered as generally indispensable. And again, though such backing is subject to the disadvantage of being fired by shells, it becomes a special and important protection of the ship's crew and force, by arresting or preventing the discharges of iron splinters, otherwise so likely to be driven into the interior.

*Extent of Armor, and Plans of Armored Vessels.*—As American practice in constructing armored vessels has thus far favored moderate or comparatively small dimensions, so it has tended most strongly to the plan of complete and nearly uniform protection of the entire hull, to a depth below which penetration becomes very unlikely. The French and English practice, directed chiefly to sea-going vessels, and hence of generally large dimensions, has been divided, but in good degree, it would appear, driven—through the desire of preserving speed—to the plans of partial armoring, as previously described. With ships of large size, it appears quite evident that—and especially as against the most recent styles of guns and projectiles—armor from stem to stern, and of a thickness to be invulnerable, is a thing utterly impracticable, at least without such a weight of metal as to sacrifice all desirable manageableness and speed. Besides, it is argued in England that, while the complete mailing of the Royal Sovereign, Prince Albert, and others, as intended for coast defence is well enough, vessels mailed on this plan could not properly lift their loaded ends in a heavy sea, so that these must in such case continually be submerged by the waves. Consequently, for large sea-going vessels, a sufficiently armored casemate, or turrets, amidships, with a broad belt of armor at the water line, a shot-proof deck being formed at the upper level of this armor belt or at water line, the hull being as much as practicable divided into compartments severally water-tight, and with pumping engines and pumps of good capacity within the protected space—such, keeping in view sea-going qualities, celerity of turning, and speed, appears to be in brief the general plan indispensable to securing at once any sufficient degree of practical invulnerability and fair chances of keeping afloat. Since there must somewhere be a shot-proof deck, the placing of this near water line does not increase the weight of the hull, though it may have some effect on its stability; but it saves a considerable weight of metal from the unarmored parts, a portion of which can well be used to strengthen the armor where applied. Again, it has been proposed, with hulls of the ordinary height out of water, to save weight

and increase the strength of armor by plating more heavily at the water-line belt, and again at the height of the battery, with a lower shot-proof deck, as before, and shot-proof passages leading from the lower protected space to that of the battery or gun deck.

Large dimensions of hull, by increasing the carrying power of the ship in a more rapid ratio than the resistance it meets with in motion, allow not only of heavy armor and armament, but also favor speed; so that, in a general way, such dimensions must be aimed at in sea-going ships. But an important increase, on the other hand, in a vessel's efficiency may be secured, as is aimed at in the Monitors, by dispensing, as far as practicable, with everything but a protected hull, a battery and its auxiliaries, and engines for propulsion, for the needful work of ventilating and pumping, and working the turret, if not of serving the guns; the latter, meanwhile, by the device of the revolving turret, being reduced in number and increased in caliber and power. The settling, however, of the Montauk's turret, under the blows of shot from Fort McAllister, and the blocking of the turrets of the Passaic and Nahant, in the attack on the forts in Charleston harbor, show that in order to secure a good degree of endurance and efficiency in actual combat, some important improvements are yet required, and, perhaps, intimate that, with small vessels of this construction, the large armaments of line-of-battle ships will have to be replaced by the large number of turrets, and so of hulls, composing an attacking fleet. Since the attack referred to, Capt. Ericsson declares that the construction of the turrets and pilothouses of the Monitors is purposely made such as to admit of the application of additional thicknesses of plating, if this (as now appears to be the fact) should be proved necessary; and he implies that all the apparent imperfections in the batteries, shown by that contest, can be readily and completely remedied.

Among the means which appear to promise a great increase in the efficiency of small batteries may be named the plan of Mr. E. A. Stevens, of "elevating and lowering, by hydraulic machinery, the turn table on which the gun carriage is fixed, so that the gun can be fired above deck, and loaded and protected, except at the moment of firing, below a shot-proof structure; and especially Mr. Stevens' arrangement for loading and cooling guns rapidly by simple steam machinery;" as well as the plan of "a rotating battery, designed by Mr. Julius King, of New Jersey, in which two or more guns are loading below deck, while another in the same revolving frame, and covered by a shot-proof hood, may be trained, elevated, and fired above deck." [Holley.]

It is stated that Mr. E. A. Stevens has recently, with the proviso that the Government shall purchase it in case of success, proposed to complete his well-known battery at his own expense, and then to submit it to the severest

tests known to modern navigation and gunnery, among its assumed qualities being a speed of 20 miles per hour, capability of turning in an extremely short time on its own centre, and invulnerability to shot of the most powerful known ordnance. This last quality is in a good degree to be derived from the submersion of the hull, during action, to such a depth that the lower deck shall be considerably beneath the surface of the water, the deflecting influence of which is held to afford the most efficient possible protection to the hold, with the engines and machinery, so enveloped. The bottom of this battery is of wood, and so, free from the fouling which proves, after a little time, so serious a barrier to speed with vessels having iron bottoms, unprotected.

The question of the best construction of hull for armored ships is, in fact, still by no means settled. The comparatively thin shell of a very usual style of iron ships, perforated by rows of holes running in the direction of the ribs, is manifestly a source of weakness in reference to transverse strains; while the shell may also be crushed in by collision with ledges of rocks, or a blow from the flukes of an anchor. To remedy these defects, it has been proposed to apply a thick wooden sheathing outside the iron shell, and over this copper or brass sheathing; and, again, to introduce a double bottom, as is done in the Great Eastern, and in the new English "shield" ships; an objection to this being that the necessary allowance of space enough between the two bottoms to admit of the entrance of workmen, diminishes greatly the available room of the hold.

Experience in this country appears not to favor the armoring of old wooden vessels for the new sort of service; but whether or not the proper hull of an armored ship were better constructed of wood, appears to be still an open question. The wooden bottoms, with or without copper sheathing, have the advantage of fouling far less than those of iron. The iron surface, acted on by salt water, rusts rapidly and unevenly, and then affords a lodgement to barnacles and seaweeds to such an extent as to unfit it for gliding easily upon the water, thus reducing the speed. Lord Palmerston declared that the Warrior fouled so fast that she lost a knot an hour in speed every six weeks she was afloat; and such vessels, if the bottoms be not in some way protected from this action, require frequent docking and cleaning, and are not so suitable for long voyages. Copper sheathing oxidizes slowly and more evenly, and thus constantly dislodges the foreign bodies that would become attached to its surface. But against wooden hulls, on the other hand, it is an objection that they work more under the action of a heavy sea than does a well-constructed shell of iron; and this is by far a more serious difficulty in the case of single thick plates than in that of laminated armor.



Hence, in England, a very strong feeling, on this score, adverse to wooden hulls exists in naval circles. It is stated that the four large frigates which lately made a trial trip to Portugal returned with their plates so loosened that they required to be at once docked and repaired. Mr. McKay, favoring wooden hulls for reasons some of which have been given, asserts that, since thick oak planking of from 40 to 60 ft. in length, can be obtained in abundance in Delaware and Ohio, and nowhere else on the globe, therefore far stronger wooden vessels can be built in America than in the old world.

One very apparent result of the great innovations which are being made in the construction of ships of war is, that but little attention is paid to ornament, or even to beauty of form. This, in view of the more vitally interesting questions that are now at issue, is not surprising; and some of the armored vessels and designs for such are not a little strange and uncouth. The decoration of the head and of the stern and quarters of these vessels is wholly sacrificed; both extremities of the ship are plain, and, in some instances, scarcely to be distinguished, unless it be by some such mark as the unsightly cowl sometimes employed to protect the rudder post where it rises through the deck. If many of the new styles of vessels have any beauty whatever, it is only of the sort that springs from utility, and a utility—in this particular class of cases—which it requires a good degree of philosophy to discover.

*Preserving the Bottoms of Armored Vessels.*

—The bottoms of wooden vessels not covered with sheathing are known to be liable to become worm-eaten; while a sheathing of iron, or an iron shell, becomes rapidly fouled. The value of copper sheathing has been above referred to, as also the method of covering iron bottoms with wood and then with copper. Against this plan it is urged that the timbers so applied give no structural strength to the ship, so that while the frame requires to be as heavy as before, the whole timber applied is so much additional expense. Brass or copper cannot be applied as a sheathing directly over an iron bottom, on account of the galvanic action and rusting of the iron that would thus be induced. Only two methods appear to remain. Of these, the first is that of sheathing with copper over iron, but with the introduction between the metals of a layer of non-conducting material, such as bitumen of Trinidad. This is the plan and material adopted by Mr. C. W. Lancaster, the bitumen being used to separate the metals and also to cause adhesion of the copper sheathing—the latter purpose being aided by copper studs tapped at considerable intervals into the iron plates, and riveted upon the surface of the copper sheets. This plan appears to be that now most generally in favor among English shipbuilders. There are those who doubt the practicability of sufficiently insulating the metals in this way, and who

rely on the second of the remaining methods, that of coating iron bottoms with some paint or composition resisting the action of salt water, and perhaps in other ways unfavorable to adhesion of barnacles and weeds. It is said that, in 1859, the British iron steamer *Himalaya* ran during nine months a distance of 26,000 miles, and in all climates, and that when docked on her return for repairs, the bottom was found quite smooth and free from rust. The bottom had been coated with red lead, and over this with a composition, chiefly of asphalt. Mr. James Jarvis, U. S. government inspector, in a letter written in 1853, declares that equal surfaces of wood and of iron, one set of each coated with three coats of red lead, and the other with three coats of zinc white, being placed during the summer in the water (salt) adjacent to the Gosport Navy Yard, at the end of the time the surfaces coated with the red lead were found quite covered with barnacles, and those coated with the zinc white entirely free. While most of the paints or compositions used for the purposes under consideration afford but partial protection and require frequent renewal, the zinc white has been found, when applied to iron bottoms of steamboats in this country, to afford the most enduring and effectual means of protection; and accordingly the bottoms of the *Dictator*, *Puritan*, and some other iron-clad vessels, are to be coated with this material.

*Rams.*—Mr. Stevens, some ten years since, determined on introducing into his battery, in order to give it efficiency in acting as a ram, engines of full 8,000 horse-power, although 4,000 would have given the speed of ordinary war vessels. It is universally admitted that, for the purposes of securing a choice of position, ability to attack with the greatest effect and upon any desired point, and if needful to escape, as well as that of passing forts with the least risk of being struck, speed of movement and celerity of turning are qualifications not less essential in rams than is actual strength of the hull and beak with which their blows are to be inflicted. Yet, singularly enough, no steam ram or vessel furnished with the appendage of a beak is yet afloat which possesses in high degree the important requisite of speed. A strong construction is secured, but not the rapid resistless dash of movement that must overtake almost any flying foe, and make the monster the most truly effective against whatever it encounters. Possibly this fundamental defect may be remedied in the Stevens Battery, the *Puritan* class, and the *Dunderberg*, when these are brought into service. With a mass so heavy as that of the ram, since its damage is due to momentum, a slightly greater speed than that of the vessel struck, and of course, if the latter be at rest, a slow movement, may suffice to do to the enemy's sides or to the screw and stern an irreparable injury, and that without racking the structure of the ram itself. It has been urged as particularly a mistaken plan to give unusual strength to the head and bow of a ram, as ne-

cessarily interfering with its speed and celerity of movement; and again, that since even a slower ship may keep her broadside away from the prow of the ram, two or more of these are much more likely to make a successful assault on even a single vessel than is one.

The means of giving sufficient speed to a ram, though perhaps difficult in practice, are so simple in principle as to require no further remark. The means of securing celerity of manœuvring are, usually, found in the use of two independent screw propellers,—as, for example, one under each quarter. By backing one of these, and driving the other in the ordinary manner, the vessel may be rapidly turned on her centre or heel. Two screws have the further advantages of allowing of the application of greater power, and of furnishing still a means of propulsion, if one, and only one, should be disabled.

In a discussion following the reading by Mr. Aston of a paper on the penetration of projectiles, before the British Association for Advancement of Science, 1862, Mr. Nasmyth is reported as saying: "The steam ram was an old subject with him. A plan was proposed by him to the Admiralty, so long ago as 1845. He thought the more destructive you can make the attack on your adversary, the better. It was not right to be torturing your enemy by drilling numerous small holes in him; it was like taking a whole day to draw a tooth. His idea was to make one large hole and sink the ship at once, with the enemy. It was a question of *momentum*. The first practical ram was the *Merrimac*, but the Southerners made a mistake in giving her a sharp end: it should be blunt. Such was the original plan of the speaker, nor had he seen any reason to alter his views. The vessel must present as low an angle as possible, to turn shot; but she must also have strength in the direction of her length, and use the utmost possible amount of steam; and to meet the objection that the impact might destroy the engines, which he did not anticipate, he would place the engines on a slide, with buffer arrangements. With such a vessel he would dash into the *Warrior* as into a handbox. The plates would be crushed at once. He hoped the Admiralty would devote a thousand pounds or two to try the effect of a ram against an old hulk, the ship *Trusty*, and afterward upon the *Warrior* herself."

*Coast and Harbor Defences.*—To the familiar modes of defence of coasts and harbors, by means of forts, shore batteries, and ordinary vessels of war, with the addition in case of the latter of sunken obstructions, chains, &c., the recent progress of naval warfare has added iron-clad ships, steam rams, cordons of submerged torpedoes, and the imminent prospect, if not yet the practice, of iron-armorings also the exposed faces of fortifications. The location of torpedoes and obstructions is simply the work of the engineer; but the immense importance of this new sort of sub-aqueous "out-

works" to harbor fortifications, as an aid in embarrassing an enemy's attack upon the latter, and a means of preventing his running them for the purpose of assault on the seaport they are intended to protect, is convincingly shown in the instance of the recent attack of the Monitor fleet on the Charleston forts; and the subject is one of which the importance cannot be over-estimated. With reference to armored vessels and rams, nothing further need here be added; the points obviously to be regarded being simply that their strength, armament, and number be, if possible, sufficient for all probable emergencies.

In respect to forts and land batteries, the superior certainty of aim and efficiency of fire of guns placed in them, over those of the guns of ships, have long been well understood; and so long as the former are supplied with ordnance of the best patterns, of the largest caliber and highest firing charge, a contest of the best armored vessels with them—their walls being of good thickness and strength—would seem to remain, as heretofore with wooden ships, a matter of doubtful result. This superiority in damaging and destructive power of forts over ships is likely, as previously intimated, to reach its maximum if the former only shall be able to mount and use the new 20-inch guns throwing 1,000-lb. shot, and more especially when the endurance of the forts themselves shall be increased by iron plating. One of the 20-inch guns, manufactured at the Pittsburg foundry, is to be mounted within Fort Tompkins at the entrance to New York bay, in April, 1868. In reference to protecting the walls of forts with iron plating, it would appear that in this case some of the difficulties experienced in armorings ships will not be encountered; and that solid plating of as large dimensions and as great thickness as can be manufactured, can here be successfully applied and far more securely fastened; so that, in simple resistance to penetration, forts are likely to have the advantage over ships. The usual elevation of their guns, often of their walls, to a considerable height above the gun deck and body of the ship, give them a double advantage in another way, that they can aim a more direct plunging fire upon the deck and sides of the ship, while the balls of the latter may have of necessity to be thrown upon their walls in a more or less oblique direction.

*Conclusions.*—The results in the way of riddling armor targets, in England, with the fire of the latest Whitworth and Horsfall guns have shown that, even before the first large and expensive fleets of armored ships built by the United States, France, and England, are fairly brought into service, a considerable portion of them all, but more especially (it would appear) of those of the two countries last named, are no better against guns that *can* now at any time be brought to bear upon them, than the old wooden walls; since the former would have, as certainly as the latter, to rely on speed and

manœuvring to escape near direct firing, and so to prolong their existence and power of aggression. The result in England has been a suspension of opinion in reference to the effectiveness of practicable iron armor, and more than this, the questioning by some authorities whether any effective armoring is not in the nature of the case an impracticable thing. In this country, the same degree of distrust on this question has not arisen; and the greater confidence existing must be traced in no inconsiderable degree to the fact of the general choice here of models for armored vessels, and plans of armoring that, for the purposes intended and the tonnage and capacity given, have unquestionably, nay, demonstrably, proved more decided successes and steps of advance in practical naval warfare, than have any or all the armored ships thus far produced by France and England. There can be little doubt that, for their tonnage, the Roanoke and Dunderberg will prove quite as formidable antagonists as any of the Royal Oak and Prince Consort class of English (similar) plated wooden ships; nor that the Puritan and Dictator, with their 10½-inch armor and four feet of oak, but practically backed also with the entire remaining deck of 40 ft. breadth, its own thickness of the sides only rising above water, will be almost absolutely invulnerable; while it must, at the least, be admitted that, when completed, these will be beyond comparison the most formidable war vessels in the world. The enduring capacities of even the smallest-size Monitors are proved abundantly by the absolute freedom from penetration and the slight actual damage with which seven of them came out from the terrific hail of projectiles poured upon them for more than an hour in Charleston harbor; and the assurance is given that even this class can be practically much further strengthened, to meet future assaults.

Still, these smaller vessels are valuable only for their purposes, and within a certain sphere of service. Mr. McKay justly urges that, while they are well fitted for defending or operating in harbors, they cannot command the high seas, take the necessary part in great naval engagements, break blockades on distant coasts, nor protect our commerce in remote parts of the world; and he anticipates that in a contest with large iron-clad frigates, they would be terribly handled, and would probably be run down. He calls attention to the fact that the French will soon have a fleet of 16 iron-cased frigates fit for foreign service and an aggressive warfare, the English 16 such frigates and 2 iron-cased corvettes, suitable for the like purposes. It may still be answered that, if the true policy of this country be anticipated to continue a defensive one, then her war navy is increasing in strength in the right direction. But Mr. McKay argues that, to be compelled to keep on the defensive is in itself a defeat; and yet, that for such purpose only, in case of

a war with any of the great naval powers, it is absolutely necessary that we have at least 20 large, powerful iron-cased frigates, that can be used also as rams, of at least 12 knots speed, capable of carrying ten days' coal, and in draught not exceeding 24 feet. These ships, he thinks, should be of wood, and copper bottomed, while, besides these, there would be need of 20 to 30 armored shell-proof corvettes, of high speed and light draught, and carrying each 10 to 12 guns.

Perhaps the practical conclusions following from the whole subject, in reference to the improvements now appearing desirable, both in the line of ordnance and of armored vessels, cannot better be expressed than in the language of Mr. Holley, in the "Atlantic Monthly," for January, 1863,—in an article from which, as well as from that by the same author in the "National Almanac," for 1863, some of the facts and deductions given in this paper, and not separately credited, have been drawn—when he says: "The direction of immediate improvement in ordnance for iron-clad warfare appears to be in the abandonment of cast iron, except as a barrel to be strengthened by steel; binding an inner tube with low-steel hoops, having a successively increasing initial tension; and the use of spherical shot at excessive velocities by means of high charges of powder in bores of moderate diameters [rather, it would appear on this point, in bores of the largest possible diameters for which the due strength of metal to bear the proportional firing charge can be secured]. The rifling of some guns is important, not so much to secure range or accuracy, as to fire elongated shells through armor. The direction of improvement in [large?] iron-clad vessels, appears to be in the concentration of armor," with shot-proof decks and bulkheads, as already described; "high speed without great increase of weight of the driving parts, by means of improved engines and boilers, and high pressure; the production of tenacious iron in large, thick, homogeneous masses; and the rapid manœuvring of heavy ordnance by machinery."

Finally, even if it should not appear altogether apposite to our subject, it is certainly apposite to *man*, who is still greater in himself than all the wonderful things he can do, and more important to himself than all that he can accomplish in his Titanic play with matter and forces, to add from a moral point of view the reflection that, to accept the struggle now going on between the means of offensive and of defensive warfare as an *end*, or as anything indeed more than a passing disturbance or convulsion running through the human mind and over the face of society, would be to put a wholly new interpretation henceforward upon the meaning and intention of all scientific advancement, and upon that more authoritative presage of nearly nineteen centuries since, conveyed in the words "On earth peace, good will toward men."

NAVY, U. S., OPERATIONS OF. The operations of the navy during the year 1862 comprise the history of several distinct squadrons. 1. The North Atlantic squadron, guarding the Virginia and North Carolina coasts, was in charge of Rear Admiral L. M. Goldsborough until Sept. 5, when he was relieved at his own request by Acting Rear Admiral S. P. Lee. 2. The South Atlantic squadron, blockading the coasts of South Carolina and Georgia and the N. E. coast of Florida, was commanded by Rear Admiral S. F. Dupont. 3. The Gulf squadron was divided in February into the Eastern Gulf squadron successively under Flag-Officer McKean, and Acting Rear Admirals Lardner and Bailey, extending from Cape Canaveral, on the E. coast of Florida, to Pensacola; and 4, the Western Gulf squadron, under Rear Admiral Farragut. 5. The Western flotilla, on the Mississippi, was until May 9 under command of Rear Admiral A. H. Foote, who was relieved by Commodore C. H. Davis; and since October 15 has been commanded by Acting Rear Admiral D. D. Porter. 6. The Potomac flotilla was under Commodore Harwood. 7. The James river flotilla was under Commodore Wilkes.

1. *North Atlantic Squadron.*—Early in January a joint naval and military expedition for operation in the waters of North Carolina sailed from Hampton Roads under the command of Flag-Officer L. M. Goldsborough, and General Burnside. (*See ARMY OPERATIONS*). The naval force, consisting of 17 light-draught vessels with an armament of 48 guns, most of them of heavy caliber, arrived at Hatteras Inlet, January 13. The battle of Roanoke Island took place on the 7th and 8th of February, the fleet commencing it by a spirited attack on the Confederate batteries and vessels, and covering the landing of the troops on the second day. At the close of the engagement the Confederate naval forces retired to Elizabeth City, pursued by the Federal flotilla under Commander S. O. Rowan, who discovered his enemy on the morning of the 10th, drawn up under a battery of four guns. Disregarding their fire, Commander Rowan pushed steadily on until within three fourths of a mile, when he delivered a volley and dashed ahead. The Confederates fled before this unexpected onset; the battery was demolished; and their whole fleet was captured or destroyed.

Flag-Officer Goldsborough having been recalled to Hampton Roads, the naval forces which accompanied Gen. Burnside to Newbern were placed under Commander Rowan. The joint expedition reached the place of landing at Slocum's Creek March 12th, and in the battle of the 14th and the occupation of Washington, N. C., on the 21st, the navy took an active part. The engagement between the Monitor and Merrimac in Hampton Roads, March 8, was narrated in the "Annual Cyclopædia" for 1861.

At the battle of West Point, May 7, the gunboats Wachusett, Maratanza, and Sebago were assigned to assist Gen. Franklin.

On the 8th of May the iron-clad vessels Monitor, Naugatuck, and four others shelled Sewall's Point near Norfolk, mainly with the view of ascertaining the practicability of landing troops there; the Merrimac or Virginia steamed out to engage them, but neither side seemed anxious to open an engagement, and both soon after retired. On the 10th Norfolk surrendered to Gen. Wool, and Commodore Tatnall, then in command of the Merrimac, proceeded to lighten his ship with the intention of taking her up the James river; but after she had been so much lightened as to be rendered unfit for action, the pilots declared there was not sufficient water to carry her beyond the Jamestown Flats, up to which point the shore on both sides was in possession of the Federal army. In this dilemma she was run ashore on Craney Island and set on fire, and on the morning of the 11th blew up.

The James river was now open for Commodore Goldsborough's gunboats, and on the 15th Commander John Rodgers was ordered to proceed with the Galena, Monitor, Aroostook, Port Royal, and Naugatuck, to Richmond, and shell the city to a surrender. They met with no artificial obstructions until they reached Ward's or Drury's Bluff, about 8 miles from Richmond, where they encountered a heavy battery and two separate barriers formed of piles and steamboats and sail vessels. The banks of the river were lined with sharpshooters who effectually prevented any attempt to remove the obstructions. The Galena ran within about 600 yards of the battery, and opened fire; the Monitor attempted to pass ahead of her, but was obliged to retire several hundred yards as her guns could not be elevated enough for effective service: the wooden vessels were ordered to keep in the rear. The Naugatuck was disabled by the bursting of her 100-lb. Parrott gun, and after an engagement of over three hours the flotilla, having exhausted their ammunition, were forced to retire without having produced much effect upon the battery. The Monitor was struck several times, but entirely uninjured. The Galena was not so fortunate; thirteen shot penetrated her iron sides, starting the knees, planks, and timbers, and killing several men by the splinters. One shell exploded in the steerage, but most of the balls, after breaking through the iron, stuck in the wood. Commander Morris, of the Port Royal, was wounded, and 13 men were killed and 11 wounded on the Galena, and 2 wounded on the Naugatuck.

On November 23 the gunboat Ellis, Lieut. W. P. Cushing, captured the town of Onslow on New River Inlet, N. C., destroying extensive salt works, and securing three schooners and 10 whale boats. On the way back, when 8 miles from the mouth of the river, the Ellis ran aground and the enemy opened fire on her. Despairing of saving the gunboat, Lieut. Cushing transferred the crew to one of his prizes, and blew up the Ellis on the 24th.

2. *South Atlantic Squadron.*—The beginning of the year found Com. Dupont's squadron actively employed in examining the waters and islands on the South Carolina and Georgia coasts, preparatory to their military occupation. On the first of January a combined attack was made by land and water upon a Confederate post at Port Royal ferry, S. C., the naval forces, consisting of 3 gunboats, 2 tugs, and 4 armed boats from the Wabash, being under the direction of Commander C. R. P. Rodgers. (See ARMY OPERATIONS.)

On January 27 a fleet of two gunboats, 4 armed steamers, and 2 armed launches under Fleet Captain C. H. Davis, accompanied by 2,400 men on transports commanded by Brig.-Gen. Wright, made a reconnoissance of Little Tybee river and the adjacent waters, with a view of preparing for the cutting off communication between Fort Pulaski and Savannah and the ultimate capture of the fort. While on this duty they were attacked by 5 Confederate vessels under Commodore Tatnall, which they repulsed after a half hour's fight, two of the enemy being driven back to Savannah, and the others running under the guns of the fort.

An expedition under Flag-Officer Dupont and Brig.-Gen. Wright, designed for the reoccupation of the principal points on the E. coast of Florida, sailed from Port Royal on the 28th of February, and captured Fort Clinch, St. Mary's, and Fernandina, March 2 and 8; Brunswick, Ga., March 7; Jacksonville, Fla., and St. Augustine, March 12, meeting with no resistance at any of these points. (See ARMY OPERATIONS.)

The capture of Fort Pulaski, in which the naval forces participated, being a purely military operation, has been described elsewhere.

On April 29 Lieutenant Rhind, with the steamer E. B. Hale, captured and destroyed a battery near the junction of the Dawho, Pow Pow, and South Edisto rivers.

On May 18 the Confederate steam tug Planter, an armed despatch and transportation steamer attached to the engineer department at Charleston under Brig.-Gen. Ripley, was brought out by her pilot, Robert Small, a very intelligent slave, and surrendered to the blockading squadron. She had on board 8 men, 5 women, and 3 children, all negroes, and was armed with a 32-pounder pivot gun, and a 24-pounder howitzer, besides which she had 4 large guns, one of them belonging to Fort Sumter, which she was to have transported that morning to the new fort on the middle ground. At 4 o'clock in the morning, while the captain was on shore, she left her wharf with Palmetto and Confederate flags flying, passed the forts, saluting as usual by blowing her steam whistle, and after getting out of reach of the last gun, hauled down the Confederate flags and hoisted a white one. The steamer, from her excellent machinery and light draught, proved a valuable acquisition to the blockaders.

On the 19th, Flag-Officer Dupont, having been led to believe, chiefly by the information given by Robert Small, that the Confederates were erecting batteries on Stono Inlet, caused a reconnoissance to be made which established the truth of the report. The inlet was immediately occupied by the gunboats and an important base thus secured for future operations against Charleston.

The military forces sent to occupy Jacksonville, Fla., after its capture in March were afterward withdrawn, and a battery was planted by the Confederates on St. John's river, some distance below the town, which caused considerable annoyance to the gunboats employed on the inside blockade of the river. Commander Steedman and Gen. Brannan accordingly moved on the 8th of September with a joint naval and land force, silenced and occupied the battery, capturing 9 guns, and afterward ascended the river as far as Lake Beresford, a distance of 230 miles, and captured a transport steamer.

The same officers had charge of a joint expedition, October 21-23, to destroy the railroad bridges near Pocotaligo, S. C. (See ARMY OPERATIONS.)

8. *Gulf Squadron and Eastern Gulf Squadron.*—In the early part of January, Flag-Officer McKeon sent the steamer Hatteras, Commander Emmons, to Cedar Keys, where about the 10th she captured or destroyed a quantity of artillery and military stores, and several schooners, the place being an important depot of the enemy.

In the latter part of March Commander Stellwagen of the *Mercedita* arrived off Appalachicola with that vessel and the *Sagamore*, and organized a boat expedition, the immediate object of which was the capture of a number of vessels understood to be at or above that city. The place, however, had already been evacuated by the Confederate troops, and the expedition met with no resistance. The inhabitants received the sailors favorably and raised the United States flag. Several vessels were brought out and others were destroyed.

On the night of April 6th a boat expedition from the bark *Pursuit*, under Acting Master Elnathan Lewis, surprised and captured at St. Andrew's the Confederate steamer *Florida*, of 500 tons, with 200 bales of cotton on board, and brought her safely out.

On the 4th of October a boat expedition from the steamer *Somerset* proceeded to the main land near Cedar Keys for the purpose of destroying some salt works, but was fired upon from a house on which a white flag was flying, and compelled to return without thoroughly accomplishing their purpose. On the 6th a stronger force, consisting of 4 boats from the *Somerset* and 4 from the gunboat *Tahoma*, landed at the same place, completing the destruction and dispersing a small guerilla force.

4. *Western Gulf Squadron.*—Captain D. G. Farragut sailed from Hampton Roads in the

U. S. steamer *Hartford* on the 8d of February, to assume the duties of flag-officer of the Western Gulf blockading squadron. In addition to the ordinary duties of the blockade, he was specially charged with the reduction of the defences guarding the approaches to New Orleans. "There will be attached to your squadron," said the Secretary of the Navy in his letter of instructions, "a fleet of bomb vessels, and armed steamers enough to manage them, all under command of Commander D. D. Porter, who will be directed to report to you. \* \* \* When these formidable mortars arrive, and you are completely ready, you will collect such vessels as can be spared from the blockade and proceed up the Mississippi river, and reduce the defences which guard the approaches to New Orleans, when you will appear off that city and take possession of it under the guns of your squadron, and hoist the American flag therein, keeping possession until troops can be sent to you. If the Mississippi expedition from Cairo shall not have descended the river, you will take advantage of the panic to push a strong force up the river to take all their defences in the rear."

Captain Farragut arrived at Ship Island on the 20th, having been detained for some time at Key West, and immediately began to organize his squadron for the important duty which had been assigned to him. There are two routes by which New Orleans may be approached by water, one through Lake Borgne and Lake Pontchartrain, and the other directly up the Mississippi river; but the former, on account of the shallowness of the water, is impracticable for any but vessels of very light draft. The Confederates had consequently devoted their labors chiefly to the fortification of the Mississippi. Some 75 miles below the city, and about 25 miles from the "passes" or mouths of the river, they had possession of two strong works constructed many years before by the U. S. Government, Fort St. Philip on the left, or N. bank, and Fort Jackson on the right. Their united armament was 126 guns, many of them of the very largest caliber. Starting opposite Fort Jackson and extending to a point a quarter of a mile below Fort St. Philip, a stout chain cable was stretched across the stream (here 700 yards wide), supported by a raft of logs and 8 hulks securely moored. Adjoining Fort Jackson was a water battery. Under cover of the forts was a fleet of 18 gunboats, the powerful iron-clad battery *Louisiana*, and the iron-clad ram *Manassas*, the naval forces being commanded by Commodore G. N. Hollins. Between New Orleans and the forts several earthworks, well armed, commanded the channel. "Our only fear," said the press of New Orleans of April 5, "is that the Northern invaders may not appear. We have made such extensive preparations to receive them that it were vexatious if their invincible armada escapes the fate we have in store for it."

To reduce these formidable defences, Captain

Farragut was able to collect the following vessels: steam sloop *Hartford*, 24 guns (flag ship), *Richmond*, 26, *Pensacola*, 24, *Brooklyn*, 24, *Mississippi*, 12, *Iroquois*, 9, *Oneida*, 9, sailing sloop of war *Portsmouth*, 17, gunboats *Varuna*, 12, *Oayuga*, 6, and *Winona*, *Katahdin*, *Itasca*, *Kineo*, *Wissahickon*, *Pinola*, *Kennebeck*, and *Sciota*, 4 each. The frigate *Colorado*, 48, could not pass over the bar, and the entrance of some of the other large ships was only effected with the expenditure of much time and labor. The mortar fleet comprised 20 schooners, each mounting one large mortar and 2 small guns. They were accompanied by the steamers *Harriet Lane*, 4, the flag ship of Commander Porter, *Miami*, 7, *Westfield*, 6, *Clifton*, 6, and *Owasco*, 5. Some of these were merely armed tugs, intended principally to serve the purpose of towing the bomb vessels into position. Including the coast-survey steamer *Sachem*, the number of vessels under Captain Farragut's command was therefore 46, and their aggregate armament, counting boat howitzers placed in the main tops, was about 300 guns and mortars. There were no iron-clads in the fleet.

Nearly three weeks were consumed in getting all the ships of the squadron over the bars at the mouths of the Mississippi. Captain Farragut found the depth considerably less than it had been laid down on the official maps; no doubt for the reason that the daily passing of large ships, before the port was blockaded, had kept the channel open. On the 28th of March Fleet Captain H. H. Bell made a reconnaissance with two gunboats from the head of the passes up toward the forts. He found the left bank quite clear of trees and bushes, but on the west side a thick wood extended about 4 miles below Fort Jackson. By the 8th of April the Mississippi and Pensacola were over the bar, and the mortar boats were moving up toward their appointed stations. On the 13th a detachment from the coast survey party set out under protection of the *Owasco*, and spent 8 days in making a minute boat survey of the river and banks, much of the time under fire, and marking the positions which the mortar vessels were to occupy. On the 18th two divisions of Commander Porter's flotilla were moored under the lee of the wood on the right bank of the river, screened from observation by the thick growth of trees interwoven with vines; the masts and rigging were dressed off with bushes, which were renewed as often as they were blown away. The head vessel was 2,850 yards from Fort Jackson and 3,680 from Fort St. Philip. The remaining division, composed of 6 vessels, was stationed under the opposite bank, the nearest being 3,680 yards from Fort Jackson. There was nothing on this side to screen them from observation, but their hulls were covered with reeds and willows.

The bombardment opened on the 18th, the mortar vessels taking the lead, and the gunboats

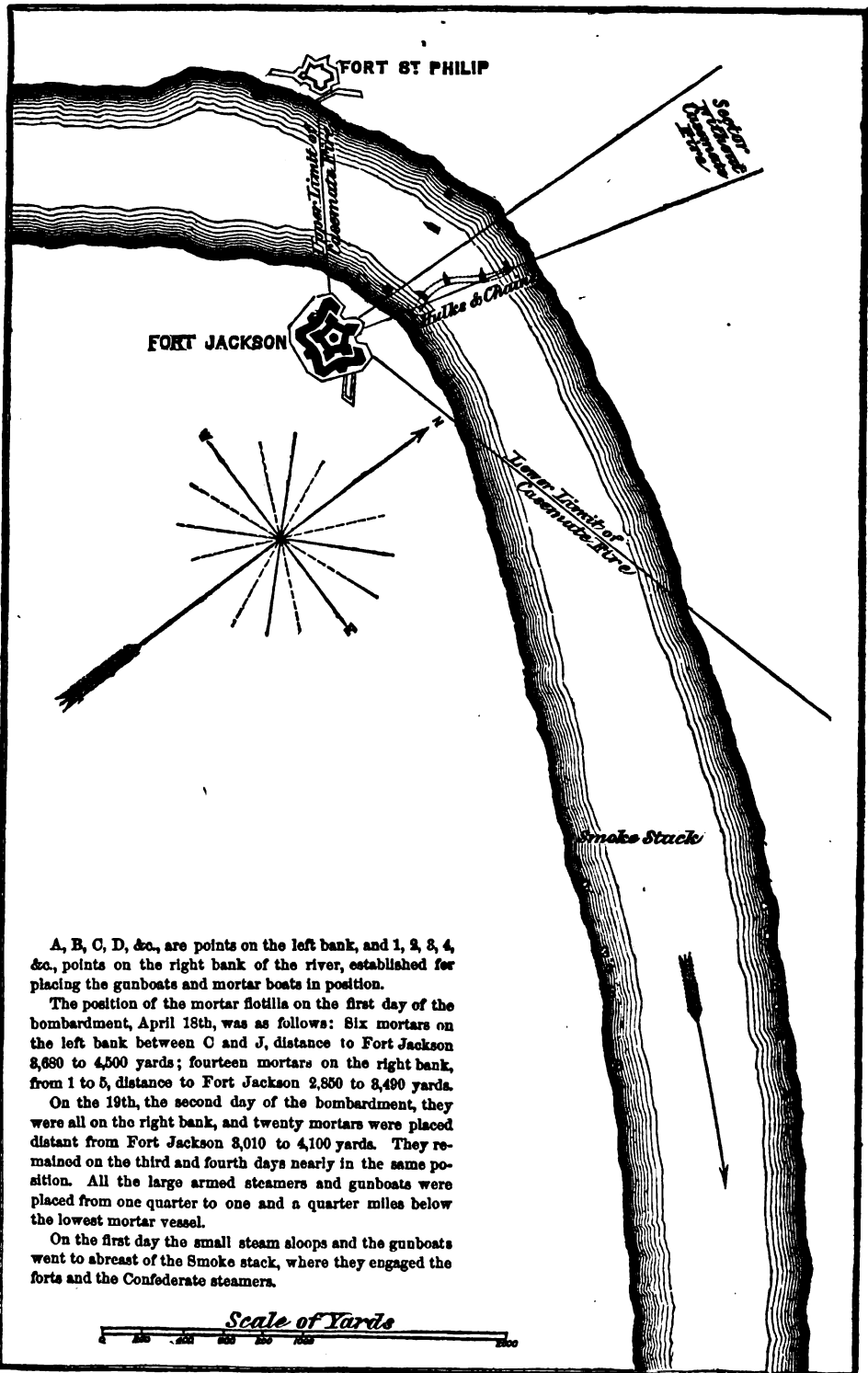

A, B, C, D, &c., are points on the left bank, and 1, 2, 3, 4, &c., points on the right bank of the river, established for placing the gunboats and mortar boats in position.

The position of the mortar flotilla on the first day of the bombardment, April 18th, was as follows: Six mortars on the left bank between C and J, distance to Fort Jackson 2,680 to 4,500 yards; fourteen mortars on the right bank, from 1 to 5, distance to Fort Jackson 2,850 to 3,490 yards.

On the 19th, the second day of the bombardment, they were all on the right bank, and twenty mortars were placed distant from Fort Jackson 3,010 to 4,100 yards. They remained on the third and fourth days nearly in the same position. All the large armed steamers and gunboats were placed from one quarter to one and a quarter miles below the lowest mortar vessel.

On the first day the small steam loops and the gunboats went to abreast of the Smoke stack, where they engaged the forts and the Confederate steamers.

running up occasionally to draw the enemy's fire when the mortars required relief. Each boat having its precise distance from the forts marked out by the surveyors, the firing was remarkably accurate. At the given signal they opened in order, each one throwing a shell every ten minutes. Fort Jackson was the principal object of attack. On the first day the citadel was set on fire and burned until two o'clock the next morning, all the clothing and commissary stores in the fort being destroyed, and great suffering caused by the intense heat. During the night the firing ceased on both sides. Two of the mortar vessels had been injured by the enemy's fire and were accordingly moved to another position. On the 19th the mortar schooner *Maria J. Carleton* was sunk by a rifle shell passing down through her deck, magazine, and bottom, but nearly all her stores and arms were saved. One or two men were wounded, but very little other damage was done except to the masts and rigging of some of the schooners. On the other hand the officers' quarters in Fort Jackson were set on fire and entirely consumed, the artillerists were driven from the parapet guns, and the batteries were silenced every time the shells were concentrated on any one point. The fuzes being bad, however, a great many exploded prematurely in the air. Commander Porter accordingly gave up timing them and put in full-length fuzes, to burst after they had entered the ground. The soil being wet and soft, the shells penetrated 18 or 20 feet into the ground, and then exploded with an effect like an earthquake. The levee was broken in more than 100 places, and the water rushing into the fort flooded the parade ground and casemates. On the night of the 20th an expedition was sent up under Commander Bell to break the obstructions across the river. With the gunboats *Pinola*, Lieut.-Com. Crosby, and *Itasca*, Lieut.-Com. Caldwell, he made for the hulks, under a heavy fire, while all the mortars opened at once upon the forts to distract the enemy's attention. Petards were arranged to blow up the boom by means of a galvanic current, but they failed to ignite. Lieutenant Caldwell however, boarding one of the hulks, managed to slip the chain, and thereby made an opening sufficiently large for the fleet to pass. His vessel was swept ashore by the current, which was running with great violence, but the *Pinola* got her off after about half an hour's labor in full sight of the forts, the terrible fire of the mortar fleet being probably the only thing that saved the two boats from destruction. The bombardment continued with undiminished vigor for 3 days longer, with little damage to the squadron. Almost every night the Confederates sent down fire rafts, but Capt. Farragut easily avoided them, and had them towed ashore. On the 23d Commander Porter succeeded in breaking a heavy rifled gun on Fort St. Philip, which had been annoying him seriously for some time. With this single exception the 6 days' bombardment had not dimin-

ished the fire of the forts in any perceptible degree.

On the 23d orders were issued to the fleet to prepare for attacking and passing the forts. The mortars were to continue the bombardment while this movement was in progress, and to try to drive the garrisons from their guns. The five steamers of Porter's flotilla, assisted by the *Portsmouth*, were assigned the duty of enfilading the water battery of six guns, and the barbette of guns which commanded the approach to the forts. The rest of the ships and gunboats were to push on past the forts, engage the Confederate fleet, and if victorious proceed to New Orleans, leaving the final reduction of the forts to Commander Porter and the land forces under General Butler. Flag-Officer Farragut now separated his gunboats into two divisions, of six boats each, the first under Capt. Theodorus Bailey, his second in command, and the second under Fleet Capt. H. H. Bell. The first division of ships comprised the flag ship *Hartford*, Commander Wainwright; *Brooklyn*, Captain Craven; and *Richmond*, Commander Alden. The second was composed of the *Pensacola*, Captain Morris, and *Mississippi*, Commander Melancton Smith. "Every vessel," says Captain Farragut, "was as well prepared as the ingenuity of her commander and officers could suggest, both for the preservation of life and of the vessel, and perhaps there is not on record such a display of ingenuity as has been evinced in this little squadron. The first was by the engineer of the *Richmond*, Mr. Moore, by suggesting that the sheet cables be stopped up and down on the sides in the line of the engines, which was immediately adopted by all the vessels. Then each commander made his own arrangements for stopping the shot from penetrating the boilers or machinery that might come in forward or abaft, by hammocks, coal, bags of ashes, bags of sand, clothes-bags, and in fact every device imaginable. The bulwarks were lined with hammocks by some, with splinter nettings made with ropes by others. Some rubbed their vessels over with mud, to make their ships less visible, and some whitewashed their decks, to make things more visible by night during the fight." On the night of the 23d Lieut. Caldwell made a second visit to the obstructions, and ascertained that the passage was still clear. He was discovered and fired upon by the enemy, who had chosen that time to send down some of their fire rafts, and had lighted fires on the shore near the chain. At two o'clock on the morning of the 24th the signal was given to get under way, and the whole squadron moved up the river in two columns, Captain Bailey in the *Cayuga* leading the right, composed of the 1st division of gunboats and the second division of ships, and the *Hartford*, with Captain Farragut, taking the post of honor on the left. On passing the barrier chain the right column attacked Fort St. Philip, and the left Fort Jackson. They were discovered some time before they reached the barrier, and both



forts opened upon them a hot fire, to which the squadron at first could only reply with their bow guns. As soon as their broadsides were brought within range the engagement became general. "The flames," said Commander Porter, "seemed to be literally eating the vessels up." In attempting to avoid a fire raft the Hartford grounded on a shoal, and in this position was set on fire, the flames bursting through the ports and running up the rigging; but, with great exertion, they were extinguished, and the ship's guns, which had meanwhile been worked without interruption, were now brought to bear upon Fort St. Philip, and that work was almost completely silenced. In the mean time, the Brooklyn and some other vessels, owing to the darkness and smoke, became entangled in the barrier, and were exposed to a raking fire from the forts for a few minutes, but managed to extricate themselves, and the Brooklyn, finding herself unexpectedly close abreast of Fort St. Philip, poured in such a storm of grape and canister that the garrison were seen, by the flash of the bursting shrapnells, running from their guns. Before the squadron had fairly passed the forts, the Confederate fleet of gunboats and rams appeared, and took part in the fight. They were first encountered by Captain Bailey in the Cayuga, who was considerably in advance of the rest, at a moment when no supporting ship was in sight. By skilful steering he frustrated their attempts to board and butt, and had forced three to surrender, when the Oneida, Commander Lee, and Varuna, Captain Boggs, hove in sight. The Oneida, discovering a Confederate gunboat crossing her bows, ran into her with a full head of steam, and cut her down, leaving her to drift down the stream with the current. The Varuna, after passing the forts, and destroying or driving ashore a gunboat and three transports, found herself, about daylight, completely surrounded by the enemy. The Governor Moore, iron-clad about the bow, first attacked her, butting her twice, and sending a raking fire along her port gangway, killing four and wounding nine of the crew; but Captain Boggs, by a few well-directed shells, drove her off, partially disabled. While still engaged with her, another Confederate steamer, iron-clad, with a prow under water, struck the Varuna in the port gangway, doing considerable damage. She backed off for another blow, and struck again in the same place, crushing in the side; "but by going ahead fast," says Captain Boggs, "the concussion drew her bow around, and I was able, with the port guns, to give her, while close alongside, five eight-inch shells abaft her armor. This settled her and drove her ashore in flames. Finding the Varuna sinking, I ran her into the bank, let go the anchor, and tied up to the trees. During all this time, the guns were actively at work crippling the Morgan (Governor Moore), which was making feeble efforts to get up steam. The fire was

kept up until the water was over the gun-trucks, when I turned my attention to getting the wounded and crew out of the vessel." Just at this moment the Oneida came up, took off some of the men from the Varuna, and completed the destruction of the Gov. Moore, which was run ashore and set on fire by the crew, part of whom afterward surrendered to Commander Lee. Three of the gunboats were obliged to put back, one having been disabled early in the action, and the others caught in the barrier chain and delayed until the day had broken and the rest of the fleet had gone past the forts. Within two hours from the commencement of the fight, nearly the whole Confederate fleet was captured or destroyed, and the victory was secured; but, "just as the scene appeared to be closing," writes Captain Farragut, "the ram Manassas was seen coming under full speed to attack us. I directed Capt. Smith, in the Mississippi, to turn and run her down. The order was instantly obeyed by the Mississippi turning and going at her at full speed. Just as we expected to see the ram annihilated, when within fifty yards of each other, she put her helm hard a-port, dodged the Mississippi, and ran ashore. The Mississippi poured two broadsides into her, and sent her drifting down the river a total wreck." As she came into the midst of Porter's flotilla, several of the mortar boats and steamers opened fire upon her; "but I soon discovered," writes Porter, "that the Manassas could harm no one again, and I ordered the vessels to save their shot. She was beginning to emit smoke from her ports, or holes, and was discovered to be on fire and sinking. Her pipes were all twisted and riddled with shot, and her hull was also well cut up. She had evidently been used up by the squadron as they passed along. I tried to save her as a curiosity, by getting a hawser around her and securing her to the bank, but just after doing so she faintly exploded. Her only gun went off, and emitting flames through her bow port, like some huge animal, she gave a plunge and disappeared under the water." About 5 o'clock the Cayuga came upon the camp of the Chalmette regiment, Col. Szymanski, on the right bank of the river. Casting anchor, Captain Bailey opened upon it with canister, and obliged the whole force to surrender, with their arms, camp equipage, &c. Soon afterward, the signal was given to cease action, and 12 vessels dropped anchor above and out of range of the forts, and began to prepare for further operations. Two of the gunboats were immediately sent ahead to cut the telegraph wires in various places, and one was sent, by way of the Quarantine bayou, to communicate with Commander Porter and General Butler. With his nine remaining vessels, Captain Farragut then proceeded up to New Orleans, meeting on the way abundant evidence of the panic which prevailed in that city. "Cotton-loaded ships, on fire, came floating down, and work-

ing implements of every kind, such as are used in shipyards." "I never witnessed such vandalism in my life," he writes to the Secretary of the Navy, "as the destruction of property; all the shipping, steamboats, &c., were set on fire and consumed." The squadron reached the English Turn about 10.30 A. M. on the 25th, and soon descried the new earthwork forts on the old lines on both shores, some 6 or 7 miles below the city; these were known as the Chalmette batteries. The fleet formed, as before, in two lines, each taking its own work, but Captain Bailey, with the Cayuga, was far in advance, not having noticed the signal for close order, and sustained alone a cross fire for about 20 minutes, at the end of which time the Hartford ranged up ahead, and gave the batteries a broadside of shells, shrapnell, and grape, the first discharge driving the men on the right bank from their guns. The Pensacola, the Brooklyn, and then the rest of the fleet, came up in quick succession, and in about 15 or 20 minutes "the forts were silenced, and those who could run were running in every direction." From this point no obstacles were encountered, except burning steamers, cotton ships, fire rafts, and the like, and at one o'clock P. M. the squadron anchored in front of New Orleans.

A terrible and melancholy spectacle was presented to the victors. The whole levee, for miles, was wrapped in smoke from the burning gun carriages and cotton which the authorities had ordered to be consumed. In the river were many hulls of burning ships, and the utmost ingenuity was required to avoid them. As the squadron neared the levee the sailors gave a cheer which was answered by some persons in the crowd on shore. Pistol shots were immediately fired at these latter by the excited multitude, and several persons were wounded. After a delay of half an hour or so, Capt. Bailey was sent ashore to demand the surrender of the city. He was received by the mob with the most violent demonstrations, but under escort of a number of citizens proceeded unmolested to the mayor's office, the mob at his heels contenting itself with furiously assaulting citizens suspected of sympathy with the Federal Union. On reaching the City Hall, Capt. Bailey demanded the surrender of the city, and the display of the United States flag over the custom house, post office, mint, and city hall. The mayor replied that he had no authority, the city being under military control, and a messenger was accordingly sent for Gen. Mansfield Lovell, the commander of the department. Gen. Lovell informed Capt. Bailey that he had already evacuated the city, and would now turn over the control to the municipal authorities, leaving them free to act as they saw fit. It was then arranged that Capt. Bailey should return to his fleet, and await the action of the common council. To the demand to haul down the flag of Louisiana from the City Hall the mayor gave an unqualified refusal. The com-

mon council was already in session, and the mayor at once sent in a message, recommending that an answer be returned to Capt. Farragut, representing that the city being incapable of offering any resistance yielded to physical force alone, without giving up its allegiance to the Confederate Government; that the custom house, post office, and mint were the property of the Confederate Government, and the municipal authorities had no control over them; and that all acts involving a transfer of authority must be performed by the invading forces themselves. The sentiments expressed in this message were unanimously adopted by the council, and on the next day the following correspondence was opened between Capt. Farragut and the mayor:

U. S. FLAG SHIP HARTFORD, off New Orleans, }  
April 26, 1862. }

*To His Excellency the Mayor of New Orleans:*

SIR: Upon my arrival before your city I had the honor to send to your honor Capt. Bailey, U. S. N., second in command of the expedition, to demand of you the surrender of New Orleans to me as the representative of the Government of the United States. Capt. Bailey reported the result of an interview with yourself and the military authorities. It must occur to your honor that it is not within the province of a naval officer to assume the duties of a military commandant. I came here to reduce New Orleans to obedience to the laws of and to vindicate the offended majesty of the Government of the United States.

The rights of persons and property shall be secured. I therefore demand of you, as its representative, the unqualified surrender of the city, and that the emblem of the sovereignty of the United States be hoisted over the City Hall, Mints, and Custom House by meridian this day; and that all flags and other emblems of sovereignty other than those of the United States be removed from all the public buildings at that hour.

I further particularly request that you shall exercise your authority to quell disturbances, restore order, and call upon all the good people of New Orleans to return at once to their vocations, and I particularly demand that no person shall be molested in person or property for sentiments of loyalty to their Government.

I shall speedily and severely punish any person or persons who shall commit such outrages as were witnessed yesterday, by armed men firing upon helpless women and children for giving expression to their pleasure at witnessing the old flag.

I am, very respectfully,  
D. G. FARRAGUT,  
Flag-Officer Western Gulf Squadron.

U. S. FLAG SHIP HARTFORD, at anchor off the }  
City of New Orleans, April 26, 1862. }

*To his Honor the Mayor of New Orleans:*

Your honor will please give directions that no flag but that of the United States will be permitted to fly in the presence of this fleet, so long as it has the power to prevent it; and as all displays of that kind may be the cause of bloodshed, I have to request that you will give this communication as general a circulation as possible.

I have the honor to be, very respectfully, your obedient servant,  
D. G. FARRAGUT,  
Flag-Officer Western Gulf Blockading Squadron.

MAYOR'S OFFICE, CITY OF NEW ORLEANS, CITY }  
HALL, April 26, 1862. }

*To Flag-Officer D. G. Farragut, U. S. Flag Ship Hartford:*

SIR: In pursuance of a resolution which we thought proper to take, out of regard for the lives of the women and children who still crowd the metropolis, Gen.

Lovell has evacuated it with his troops, and restored back to me the administration of its government and the custody of its honor.

I have, in council with the City Fathers, considered the demand you made of me yesterday of an unconditional surrender of the city, coupled with a requisition to hoist the flag of the United States on the public edifices and haul down the flag that still floats upon the breeze from the dome of this hall.

It becomes my duty to transmit to you an answer which is the universal sentiment of my constituents, no less than the promptings of my own heart on this sad and solemn occasion.

The city is without the means of defence, and is utterly destitute of the force and material that might enable it to resist the overpowering armament displayed in sight of it.

I am no military man, and possess no authority beyond that of executing the municipal laws of the city of New Orleans. It would be presumptuous in me to attempt to lead an army to the field, if I had one at command, and I know still less how to surrender an undefended place, held as this is at the mercies of your gunners and your mortars.

To surrender such a place were an idle and unmeaning ceremony. The city is yours by the power of brutal force, not by my choice or the consent of the inhabitants. It is for you to determine the fate that awaits her. As to hoisting any flag not of our own adoption or allegiance, let me say to you that the man lives not in our midst whose hand and heart would not be paralyzed at the mere thought of such an act; nor could I find in my entire constituency so desperate and wretched a renegade as would dare to profane with his hand the sacred emblem of our aspirations.

Sir, you have manifested sentiments which would become one engaged in a better cause than that to which you have devoted your sword. I doubt not that they spring from a noble though deluded nature, and I know how to appreciate the emotions which inspired them. You have a gallant people to administrate during your occupancy of this city—a people sensitive to all that can in the least affect their dignity and self-respect.

Pray, sir, do not fail to regard their susceptibilities. The obligations which I shall assume in their name will be religiously complied with. You may trust their honor, though you might not count on their submission to unmerited wrongs.

In conclusion, I beg you to understand that the people of New Orleans, while unable to resist your force, do not allow themselves to be insulted by the interference of such as have rendered themselves odious and contemptible by their dastardly desertion of our cause in the mighty struggle in which we are engaged, or such as might remind them too forcibly that they are the conquered and you the conquerors.

Peace and order may be preserved without resort to measures which I could not at this moment prevent.

Your occupying the city does not transfer allegiance from the government of their choice to one which they have deliberately repudiated, and that they yield the obedience which the conqueror has a right to extort from the conquered. Yours, respectfully,

JOHN F. MONROE, Mayor.

U. S. FLAG SHIP HARTFORD, at anchor of the City }  
of New Orleans, April 23, 1862. }

To His Honor the Mayor and City Council of the City of New Orleans:

Your communication of the 26th instant has been received, together with that of the City Council.

I deeply regret to see both by their contents, and the continued display of the flag of Louisiana on the court house, a determination on the part of the city authorities not to haul it down. Moreover, when my officers and men were sent on shore to communicate with the authorities, and to hoist the United States flag on the Custom House, with the strictest order not to use their arms unless assailed, they were insulted in the grossest manner, and the flag which had been

hoisted by my orders on the Mint was pulled down and dragged through the streets.

All of which goes to show that the fire of this fleet may be drawn upon the city at any moment, and in such an event the levee would, in all probability, be cut by the shells, and an amount of distress ensue to the innocent population, which I have heretofore endeavored to assure you that I desire by all means to avoid.

The election, therefore, is with you. But it becomes my duty to notify you to remove the women and children from the city within forty-eight hours, if I rightly understood your determination.

Very respectfully, your obedient servant,  
(Signed) D. G. FARRAGUT,  
Flag-Officer, Western Gulf Blockading Squadron.

CITY HALL, April 23, 1862.

To Flag-Officer D. G. Farragut, United States Flag Ship Hartford:

Your communication of this morning is the first intimation I ever had that it was by your strict orders that the United States flag was attempted to be hoisted upon certain of our public edifices, by officers sent on shore to communicate with the authorities. The officers who approached me in your name disclosed no such orders and intimated no such design on your part, nor would I have for a moment entertained the remotest suspicion that they could have been invested with power to enter on such an errand while the negotiations for a surrender between you and the city authorities were still pending. The interference of any force under your command, as long as those negotiations were not brought to a close, could not be viewed by us otherwise than as a flagrant violation of those courtesies, if not of the absolute rights, which prevail between belligerents under such circumstances. My views and sentiments with reference to such conduct remain unchanged. You now renew the demand made in your former communication, and you insist on their being complied with unconditionally, under a threat of bombardment within forty-eight hours; and you notify me to remove the women and children from the city, that they may be protected from your shells.

Sir, you cannot but know that there is no possible exit from this city for a population which still exceeds in number one hundred and forty thousand, and you must therefore be aware of the utter inanity of such a notification. Our women and children cannot escape from your shells, if it be your pleasure to murder them on a question of mere etiquette. But if they could, there are but few among them who would consent to desert their families and their homes, and the graves of their relatives, in so awful a moment. They would bravely stand the sight of your shells tearing up the graves of those who are so dear to them, and would deem that they died not ingloriously by the side of the tombs erected by their piety to the memory of departed relatives.

You are not satisfied with the possession of an undefended city, opposing no resistance to your guns, because of its bearing its hard fate with something of manliness and dignity, and you wish to humble and disgrace us by the performance of an act against which our natures rebel. This satisfaction you cannot expect to obtain at our hands.

We will stand your bombardment, unarmed and undefended as we are. The civilized world will consign to indelible infamy the heart that will conceive the deed and the hand that will dare to consummate it.

Respectfully,  
JOHN T. MONROE,  
Mayor of the City of New Orleans.

UNITED STATES FLAG-SHIP HARTFORD, At Anchor }  
off the City of New Orleans, April 23, 1862. }

To His Honor the Mayor of the City of New Orleans:

SIR: The Forts St. Philip and Jackson having surrendered, and all the military defences of the city being either captured or abandoned, you are required, as the sole representative of any supposed authority in the city, to haul down and suppress every ensign and

symbol of Government, whether State or Confederate, except that of the United States. I am now about to raise the flag of the United States upon the Custom House, and you will see that it is respected with all the civil power of the city.

I have the honor to be, very respectfully, your obedient servant,  
D. G. FARRAGUT,  
Flag-Officer, Western Gulf Blockading Squadron.

UNITED STATES FLAG SHIP HARTFORD, At Anchor }  
off the City of New Orleans, April 20, 1862. }

GENTLEMEN: I informed you in my communication of the 28th of April, that your determination, as I understood it, was not to haul down the flag of Louisiana on the City Hall, and that my officers and men were treated with rudeness when they landed, even with a flag of truce, to communicate with the authorities, &c., and, if such was to be the determined course of the people, the fire of the vessels might at any moment be drawn upon the city. This you have thought proper to construe into a determination on my part to murder your women and children, and made your letter so offensive that it will terminate our intercourse; and so soon as General Butler arrives with his forces I shall turn over the charge of the city to him and assume my naval duties. Very respectfully, &c.,

D. G. FARRAGUT,  
Flag-Officer Western Gulf Blockading Squadron.  
His Honor the Mayor and City Council of New Orleans

Captain Farragut then seized all the steamboats which had not been destroyed,—among them the famous Tennessee, for which the blockaders had long been watching—and sent them down to Quarantine for General Butler's forces. There were several iron-clad rams building, at the time of the capture of the city, the principal one of which, the Mississippi, soon came floating by in flames. Another was sunk in front of the custom house, and there were others at Algiers, opposite New Orleans, just begun.

"I next went above the city eight miles, to Carrollton," writes Captain Farragut, "where I learned there were two other forts; but the panic had gone before me. I found the guns spiked, and the gun carriages in flames. The first work, on the right, reaches from the Mississippi nearly over to Pontchartrain, and has 29 guns; the one on the left had 6 guns, from which Commander Lee took some 50 barrels of powder, and completed the destruction of the gun carriages, &c. A mile higher up there were two other earthworks, but not yet armed.

"We discovered here, fastened to the right bank of the river, one of the most Herculean labors I have ever seen—a raft and chain to extend across the river to prevent Foote's gunboats from descending. It is formed by placing three immense logs of not less than three or four feet in diameter, and some thirty feet long: to the centre one a 2-inch chain is attached, running lengthwise the raft; and the three logs and chain are then frapped together by chains from one half to one inch, three or four layers, and there are 96 of these lengths composing the raft. It is at least three quarters of a mile long. \* \* \*

"I sent on shore and hoisted the American flag on the custom house, and hauled down the Louisiana State flag from the city hall, as the mayor had avowed that there was no man

in New Orleans who dared haul it down; and my own convictions are that if such an individual could have been found he would have been assassinated."

The operations of Commander Porter below the forts were as follows: As soon as Captain Farragut was ready to proceed, the five steamers attached to the mortar flotilla moved up and took position under the batteries, the leading vessel 500 yards off, and the others closing up as the fire commenced. As soon as the Hartford, Brooklyn, and Richmond passed they opened with shrapnell on the water battery and forts, having received the fire ten or fifteen minutes before replying to it. As the fire was high and they were close in shore, nearer the forts than the enemy supposed, they occupied, as it turned out, a safer position than the vessels farther out, there being only one killed and one wounded on board the Harriet Lane, while the other steamers remained untouched. The mortars meanwhile poured a heavy fire upon Fort Jackson. In one hour and ten minutes from weighing anchor, the fleet had passed the forts, and Commander Porter, having accomplished his part, hung out the signal to retire, and sent Lieutenant Commanding Guest with a flag of truce to demand the surrender of the forts. The flag was fired upon and put back, but a boat soon came down with an apology and received the summons, to which Lieut.-Col. Higgins, commanding the forts, replied that until he received official information of the fall of New Orleans no proposition for a surrender could be for a moment entertained. Giving the men one day to rest, Commander Porter resumed the bombardment on the 26th, but there was no response. Learning that the formidable iron-clad battery Louisiana, mounting 16 heavy guns, had escaped Captain Farragut, and with three Confederate steamers which the flotilla had also left behind them, was about to make an attack upon the mortar boats, he sent the schooners, which would have been almost defenceless against such an adversary, down the river to refit and prepare for sea, six of them having orders to pass around to the rear of Fort Jackson to prevent supplies from getting in, and two being sent to the rear of Fort St. Philip to assist in landing troops. Three of them drifted over to the mouth of Barataria Bay, and received the surrender of Fort Livingston. On the 27th, the possession of the forts being an urgent necessity, Commander Porter renewed the demand, offering honorable terms, the officers to retain their side arms, and both officers and men to be paroled, private property to be respected, the arms and munitions of war and public property to be surrendered, and no damage to be done by the garrison to the defences. These terms were accepted the next day, partly, no doubt, in consequence of the landing of General Butler at Quarantine in the rear of Fort St. Philip, which entirely cut off reinforcements; and partly, according to Command-

er Porter, on account of disaffection in the garrison. Two hundred and fifty in fact of the garrison of Fort Jackson, after spiking the guns bearing up the river, surrendered themselves to Gen. Butler's pickets on the night of the 28th, averring that they had been impressed and would fight no longer. While the capitulation was being drawn up, the Confederate naval officers towed the ram Louisiana to a point above the forts, and having set her on fire, turned her adrift, with guns shotted, in the expectation that she would explode in the midst of the fleet. The final catastrophe, however, took place sooner than they had hoped. Just as the battery got abreast of Fort St. Philip it blew up with a tremendous noise, and sunk immediately. The only injury was to a Confederate soldier in the fort, who was killed by one of the fragments. As soon as the capitulation was completed, the Harriet Lane turned her attention to the three Confederate steamers which were lying about half a mile above. One of them had already been scuttled; the others surrendered without resistance, and 14 officers, 7 engineers, the crews of the steamers, and 800 men and two companies of marine artillery belonging to the Louisiana became prisoners of war. The men were released on parole; the officers, in consequence of their conduct in setting fire to the battery, and attempting to destroy the fleet while a capitulation was in progress, were sent to the North as close prisoners. Gen. Phelps now arrived, and Porter turned over to him the forts, guns, and captured property. The loss of the Confederates during the bombardment was 14 killed and 89 wounded. The casualties in the fleet were, during the six days' bombardment, 2 killed and 24 wounded; during the passing of the forts and the engagement with the Chalmette batteries, 37 killed, and 147 wounded; on board the mortar boats, 1 killed and 6 wounded; total, 40 killed, and 177 wounded. Fort St. Philip was very little injured, only one of the mortars having fired upon it, because its fate evidently depended upon that of Fort Jackson. The latter was described by Commander Porter after the surrender as "a perfect wreck." Over 1,800 shells fell inside the work proper, 170 in the water battery, and by the estimate of the soldiers, about 3,000 in the ditches around the works. All the buildings in and near the fort were burnt; the ramparts were severely damaged on every side, and particularly on the north, but had been repaired with sand bags which were constantly sent down from New Orleans during the bombardment; the walls of the citadel were cracked in many places very badly; the casemates were cracked from end to end, several of them showing wide fissures in the roofs and sides, and their floors were three inches under water. Still there is little question that, but for the interruption of their communications with New Orleans, these works could have held out much longer, the extent of the damage being far from

proportionate to the time and powder expended in the bombardment. If the formidable 18-inch mortars did not fully answer the expectations which had been formed of them, this fact must be attributed first to the softness of the soil which allowed the shells to sink 20 feet, by measurement, before they exploded, and secondly to the difficulty of getting accurate range: the forts rose but little above the surrounding bushes, and the vessels which were moored behind the wood often had to fire almost at random; the mortars could only be pointed from sights fixed to the mast heads, and the most curious expedients were resorted to for obtaining correct firing.

After the conquered forts and city had been occupied by the military forces, Commander Porter was ordered to repair to Ship Island. The Portsmouth, the Pensacola, and one gunboat were stationed at New Orleans; seven vessels were sent up the river under command of Captain Craven, "to keep up the panic;" and the smaller steamers, under command of Captain Lee, were ordered to ascend as far as Vicksburg.

Commander James S. Palmer arrived off Baton Rouge with the Iroquois, May 7, and demanded the surrender of the town and all property belonging to the Confederate Government, promising to respect the rights and property of private citizens, but requiring that the United States flag should be hoisted on the arsenal. The mayor, while admitting that the city was without the means of resistance, refused to surrender or to hoist the flag. Com. Palmer accordingly landed a force and took possession of the arsenal, and Flag-Officer Farragut arriving soon afterward took measures to secure proper respect for the national ensign, and to cause all other flags to be suppressed.

On the 12th the Iroquois anchored off Natchez in company with several other vessels, and Commander Palmer sent on shore a demand for surrender which the people at the wharf refused to receive. He then made dispositions for landing an armed force, but was met at the shore by a deputation from the common council with an apology for the previous refusal. The mayor sent a reply to the summons similar to that given by the mayor of Baton Rouge, but he issued a proclamation urging the citizens to commit no act to provoke the displeasure of the United States forces. As Natchez however had never been occupied as a military position, Commander Palmer deferred taking formal possession of it.

Commander S. P. Lee with the advance of the squadron arrived near Vicksburg, May 18, and in reply to his demand for surrender received a defiant refusal. He then gave 24 hours for the removal of women and children, after which time he declared he should consult his own judgment as to the propriety of immediately opening fire. Flag-Officer Farragut arrived a few days afterward, accompanied by a column of troops under General Williams. Subsequent-

ly an additional naval and military force was brought up, including Porter's mortar fleet, and the latter opened the bombardment on the night of June 26-27, directing their fire partly against the town and partly against some formidable batteries on the heights. On the morning of the 27th the *Owasco*, Lieut. Guest, ran up abreast of the town and threw in some incendiary shells, which failed to explode. At 8 o'clock on the morning of the 28th the squadron made a move to pass the batteries, the mortar fleet supporting them as at the battle of Forts Jackson and St. Philip. The Hartford and several other vessels succeeded in passing the range of batteries, which extended full 8 miles, and did this too in the face of a strong current, but as there was not a sufficient land force to cooperate in the attack, no substantial benefit resulted from the movement. The enemy were several times driven from their batteries, but returned to their guns as soon as the ships had passed. Forming a junction with the western gunboat flotilla of Flag-Officer C. H. Davis, Farragut concerted with that officer and General Williams an expedition up the Yazoo river, consisting of the gunboats *Carondelet* and *Tyler* and the ram *Queen of the West*, strengthened by sharpshooters from the army. They started on the morning of July 15, and near the mouth of the river encountered the Confederate ram *Arkansas*. A severe fight ensued, in which both the *Carondelet* and the *Tyler* were partially disabled, and the *Arkansas* then entered the Mississippi and passing boldly through the surprised fleets of Farragut and Davis, took refuge under the guns of Vicksburg. Farragut now determined to repass the batteries, for the double purpose of supporting the rest of his squadron and destroying the *Arkansas* in passing; to assist in which Flag-Officer Davis added to his force the ram *Sumter*, Lieutenant Commanding Erben. Toward evening Davis opened a bombardment, for the purpose of covering the movement, and Captain Farragut succeeded in getting below Vicksburg again with little loss of life, but his designs against the *Arkansas* were defeated by the darkness of the night. On the 22d Commander W. D. Porter with the iron-clad gunboat *Essex*, and Lieut.-Col. Ellet, with the ram *Queen of the West*, made another attempt to destroy the Confederate vessel, but the attack though executed with great gallantry under the fire of the batteries did not succeed. The *Essex* ran down to Farragut's fleet, and Farragut having been instructed by the navy department to drop down the river before the water got too low, it was arranged that Commander W. D. Porter should remain below Vicksburg with the *Essex* and *Sumter*.

On the 28th of July Farragut arrived at New Orleans, leaving the *Katahdin* and *Kineo* at Baton Rouge. On the 5th of August the Confederates made a vigorous land attack upon the latter place, which was repulsed after a severe contest. The gunboats were not able to assist

until toward the close of the action, when they threw their shells directly into the midst of the enemy with great effect. The *Arkansas* had dropped down the river to take part in the attack, but was not brought into action, one of her engines having broken down. The next morning Porter who was then at Baton Rouge with the *Essex*, moved up to attack her, but before the fight had fairly begun her other engine gave way, and she was run ashore, abandoned, and set on fire by the crew. About an hour afterward she blew up. On the 11th Farragut sailed for Ship Island and Pensacola, which latter place, having been evacuated by the Confederates, was now made the depot of the Western Gulf squadron.

Commander W. D. Porter remained at Baton Rouge until August 23, when, the town having been evacuated by the Federal troops, he proceeded up the river to reconnoitre batteries reported to be erecting at Port Hudson, and thence ascended to Bayou Sara to obtain coal, where his boat's crew was fired upon by guerillas. Some of the buildings were thereupon burned, and a few days afterward, as the firing was repeated, the rest of the place was destroyed. Afterward, a boat's crew from the *Essex*, sent ashore at Natchez to procure ice for the sick, was attacked by some 200 armed citizens, one of the sailors being killed, and an officer and 5 men wounded. Commander Porter immediately opened fire on the town, set a number of houses in flames, and continued the bombardment for an hour, after which the mayor surrendered. On her way down to New Orleans, the *Essex* had a brisk engagement, on September 7, with the Port Hudson batteries.

In the mean time, several vessels of Captain Farragut's squadron had been employed on the coast of Texas, where acting volunteer Lieutenant J. W. Kittredge, with the bark *Arthur*, the little steamer *Sachem*, and a launch, captured *Corpus Christi*, after several spirited engagements with the enemy's batteries, but was unable to hold the town, and was himself made prisoner, Sept. 14, while on shore exploring.

On September 26, Acting Master Crocker, with the steamer *Kensington* and schooner *Rachel Seaman*, and Acting Master Pennington, with the mortar schooner *Henry Jones*, captured *Sabine Pass*, taking a battery of 4 guns without loss.

On the 4th of October, Commander W. B. Renshaw, with the steamers *Westfield*, *Harriet Lane*, *Owasco*, and *Clifton*, and the mortar schooner *Henry Jones*, captured the defences of the harbor and city of Galveston without the loss of a man. The resistance was feeble: the first shell from the *Owasco* burst immediately over a heavy 10-inch Columbiad mounted on Fort Point, causing a panic in the fort, and depriving the defenders of their main reliance.

Toward the end of October, Lieutenant Commander T. McKean Buchanan, with the

steamers Calhoun, Estrella, Kinsman, and Diana, and the transport St. Mary's, having on board the 21st Indiana regiment, was sent to the Atchafalaya river, La., to cooperate with a land force under General Weitzel. On Nov. 1, near Brashear City, he captured the Confederate despatch boat A. B. Seger, and the next day had an engagement with an iron-clad gunboat and some land batteries on the Bayou Téche. The batteries were silenced, but the gunboat, being behind a row of obstructions across the channel, escaped up the river. Lieutenant Commander Buchanan then returned to Brashear City to repair damages. On the 6th, the Kinsman discovered and burned two steamers in one of the small bayous in the neighborhood.

5. *Western Flotilla*.—Nearly all the operations of this squadron, which was fitted out and, until October, was controlled by the War Department, have been mentioned in the article ARMY OPERATIONS, and the first attack on Vicksburg has been described in the account of Captain Farragut's movements. When the attempt to reduce Vicksburg was, for the time, abandoned, Flag-Officer Davis withdrew his fleet to the mouth of the Yazoo.

On June 13, a detachment from the squadron, under Commander Kilty, with the 46th Indiana regiment, under Col. Fitch, left Memphis for White river, Ark. (See ARMY OPERATIONS.)

Early in August, an expedition was concerted between Flag-Officer Davis and General Curtis, which moved up the Yazoo, and captured a battery of heavy guns, field pieces, munitions of war, &c., besides taking the Confederate transport Fairplay, loaded with 1,200 Enfield rifles, 4,000 new muskets, 4 field guns, mounted howitzers, small arms, a quantity of fixed ammunition, &c.

On the 26th of September, the ram Queen of the West and two transports having been fired into by the Confederates at Prentiss, Miss., the town was shelled and burned.

On December 13th the gunboat Cairo, while ascending the Yazoo, was blown up by a torpedo, and sank in 15 minutes after the explosion. It is remarkable that none of the crew were killed, or even seriously hurt.

6. *Potomac Flotilla*.—The operations of this force, except in checking contraband traffic, were comparatively unimportant. On Jan. 2, the gunboats Anacostia and Yankee had an engagement with the Confederate batteries at Cockpit Point, which they silenced.

After the evacuation of the Confederate batteries on the Potomac, in March, and the removal of General McClellan's army to the peninsula, the Rappahannock was added to the waters intrusted to this squadron; but, beyond a few skirmishes with batteries on the shores, the capture of some small craft, and an attack, on December 10, upon the Confederate batteries at Port Royal, below Fredericksburg, the flotilla had little opportunity for action.

7. *James River Flotilla*.—After the removal

of General McClellan's army to the James river, a new squadron was organized (July 6) for operations on that stream, and intrusted to the command of Commodore Charles Wilkes, who, on August 28, shelled and destroyed City Point, from which place the Confederates had fired upon the U. S. transports in the river. The removal of the army to the Potomac rendered the flotilla no longer necessary in the James river, and it was accordingly disbanded, August 31.

The vessels thus placed at the disposal of the Government were then organized as a flying squadron, to cruise chiefly in the West Indies in search of ships engaged in running the blockade. Commodore Wilkes was retained in the command.

Several other vessels were engaged during the year in pursuit of the privateers Sumter and Alabama, the former of which after being tracked to Gibraltar, was there blockaded by a Federal gunboat so closely that her commander was obliged to sell her.

According to the annual report of the Secretary of the Navy, Dec. 1, 1862, the blockading squadron had captured and reported to the department, since the date of the previous annual report, 390 vessels attempting to violate the blockade, a few of which were destroyed. Of the large number of prizes sent in for adjudication, in only 45 had the proceedings at that date been brought to a close.

NELSON, WILLIAM, major-general of volunteers in the U. S. army, born in Maysville, Mason co., Ky., in 1825, was killed at Louisville, Ky., Sept. 29, 1862. He entered the naval school at Annapolis at the age of fifteen, and, upon graduating, was appointed a midshipman in the U. S. navy. He was first attached to the sloop-of-war Yorktown, in commission for the Pacific, and soon after joined that squadron under Commodore T. Ap Catesby Jones. In 1846 he received his commission as passed midshipman, and was ordered to the frigate *Raritan*, attached to the home squadron, and flag ship of Commodore Conner. In 1847 he was made acting master of the steamer *Scourge*, under the command of Com. Perry. At the siege of Vera Cruz, during the Mexican war, he won a high reputation in command of a navy battery. In 1854 he was promoted to the rank of master, and ordered to the frigate *Independence*, stationed in the Pacific. In 1858 he was ordered to the *Niagara* when she carried back to Africa the negroes taken from the steamer *Echo*. At the commencement of the present war he was on ordnance duty at the Washington navy yard, and was detailed to command the Ohio river fleet of gunboats, having received the rank of lieutenant commander, but was soon after transferred to the army for the purpose of influencing volunteers in Kentucky, his native State. He organized "Camp Dick Robinson," between Garrardsville and Danville, and another camp at Washington, in Mason co. He

fought several engagements with Humphrey Marshall, in some of which he was successful. In Sept. 1861 he was made brigadier-general, and appointed to the command of the second division of Gen. Buell's army. He won much distinction at the battle of Shiloh, was wounded at the battle of Richmond, Ky., and afterward assumed command of all the forces in Louisville, having been made major-general of volunteers, July 17, 1862. His overbearing nature made him unpopular with his associates, and he was shot in his hotel by Brigadier-General Jefferson C. Davis, in a moment of resentment for his harsh and unjust treatment of that officer.

NESSELRODE, COUNT KARL ROBERT VON, a Russian statesman, born on board of a Russian frigate in the harbor of Lisbon, Dec. 14, 1770, died at St. Petersburg, March 28, 1862. His father was a Russian diplomatist though originally of German family, and at the time of his birth was ambassador to Portugal. Young Nesselrode received an excellent education and early entered the army as aide-de-camp to the Emperor Paul, but was soon made an attaché to the various embassies of his father, and subsequently served in the same capacity under M. Markoff, Russian minister at Paris. On the rupture between Russia and France, which followed the execution of the Duke d'Enghien, he was transferred to the legation at the Hague under Prince Dolgorouski, and in 1805-6, when the prince returned to Russia, remained there as *chargé d'affaires*, till the accession of Louis Bonaparte made his withdrawal necessary. In 1807, he was again sent to Paris as a councillor of legation. His diplomatic papers were very brilliant, and gained him the favor of the Emperor Alexander I. He was secretly in favor of Napoleon, though professing to be attached to the cause of the Allies. In July, 1807, he accompanied his imperial master, when he and Napoleon had their interview on the raft at Tilsit, and assisted afterward at the treaty made at that time. Soon after this event, he returned to St. Petersburg, where he married the daughter of M. (afterward Count) Gurieff, then finance minister, and was himself appointed to a subordinate position in the office of foreign affairs. His wife had been maid of honor to the empress dowager, and was supposed to possess considerable financial ability, which was exerted to increase her husband's fortune. In 1812, after the rupture with Napoleon, Von Nesselrode was made Secretary of State for Foreign Affairs, and intrusted with powers in this important department second only to the minister *en chef*, Count Razumoffski. His views of policy differed materially from those of his chief, and in 1813 a coalition was formed by which he became supreme in the direction of the foreign policy of the empire. The treaties with England, Sweden, Prussia, and Austria, which followed, were dictated by him, and the downfall of Napoleon was due in part at least to his influence. On

the 31st of March, 1814, he signed the capitulation of Paris. At the Congress of Vienna, Nesselrode, Metternich, and Talleyrand were the leading spirits. Thoroughly absolutist in his views and tendencies, he was yet so remarkable for the apparent moderation and suavity of his manners, and his diplomatic skill and tact, that he maintained the superiority of Russia in the European councils for 42 years, and yet during nearly 40 years of that time, avoided involving his country in war with any of the great powers. During the reign of Alexander I., he was, with the exception of a short period in which the Count Capo d'Istria had succeeded in alienating the confidence of the emperor, the supreme authority in regard to the foreign policy of the Russian empire. On the accession of Nicholas I., in 1827, he still retained his position, though, from the stronger will and more positive character of that monarch, he was under the necessity of acting more cautiously and influencing the czar to suggest views and measures, which he had previously determined upon. He remained at the head of the Government throughout the reign of Nicholas, and in 1856, on the 30th of March, just 42 years after he had in the same city signed the capitulation of Paris, he signed on behalf of Russia the treaty of Paris. He then retired from active political life, in which he had acted a conspicuous part for more than 50 years. His wealth was immense; upward of 150,000 sheep grazed on his estates, and his personal property was so great that he was reckoned one of the wealthiest men in Europe. He was passionately fond of cookery, and invented many new and famous dishes, among which his pudding à la Nesselrode has had the greatest reputation. In his intercourse with his subordinates Von Nesselrode was remarkable for kindness and considerateness, and the interest he took in their prosperity.

NEW HAMPSHIRE, one of the New England States, during the ten years preceding 1860, increased in population 8,097. The population of the State at the end of that period was 326,073. For the further statistics of New Hampshire furnished by the details of the last census, so far as they are accessible, the reader is referred to the article entitled UNITED STATES.

The officers of the State are elected annually at an election held on the second Tuesday in March. At the election in 1862, the candidates for governor were Nathaniel S. Berry, then governor, George Stark, and Paul J. Wheeler. The first was nominated by the republican party, the second by the democratic party, and the third by a convention representing citizens who were opposed to continuing the party lines by which the people had been divided. The Republican Convention had assembled at Concord on Jan. 1st, 1862, and made the above mentioned nomination, and adopted a series of resolutions ignoring past political topics, and avowing the unreserved purpose of supporting the Government, and urging the vigorous pres-



ection of the war. The Democratic Convention assembled at the same place, on the 8th of January, and nominated the above mentioned candidate, and adopted a series of resolutions expressing a firm and uncompromising spirit in favor of sustaining the Union and the Constitution, and opposed to all departure from, or violation of the latter. The Independent Convention assembled at Concord, on the 6th of February, and nominated their candidate, and adopted resolutions declaring that the maintenance of political organizations at that time was out of place, and that every patriotic citizen should rally to the support of the Government.

The votes of the citizens were cast as follows: Berry, 32,150; Stark, 28,566; Wheeler, 1,709.

The majority for Lincoln over Douglas for the Presidency in 1860 was 11,638.

The vote for governor in 1861 was as follows: Berry, 35,487; Stark, 31,452; Bartlett, 181.

The votes for members of the Legislature produced the following results:

	Senate.	House.
Republicans .....	9	203
Democrats .....	3	120

This Legislature, at an extra session near the close of the year, adopted the following resolutions as expressive of the views of the majority on public affairs:

*Resolved by the Senate and House of Representatives of the State of New Hampshire in General Court convened:* That the contest now existing between the Government and the disloyal people that have commenced an unjustifiable and treasonable war upon its constitutional authority, should be regarded by all loyal men not as a sectional war, not an anti-slavery war, nor a war of conquest and subjugation, but simply and solely a war for the maintenance of the Government, the suppression of rebellion, and the preservation of the *magna charta* of our liberty and national unity.

*Resolved,* That the State of New Hampshire pledges her resources for the integrity of the Union, for the support of the Constitution, and for the enforcement of the laws of the General Government.

*Resolved,* That the Constitution is the supreme law of the land, and that no State has the right to secede therefrom and dissolve the Union which that Constitution was made to secure.

*Resolved,* That the duty of the General Government to suppress all attempts to dissolve the Union is imperative, and cannot be evaded.

*Resolved,* That neither the President nor Congress can constitutionally entertain any proposition which has for its object the dismemberment of the Government or the dissolution of the Union.

*Resolved,* That, in the language of Andrew Jackson, "The Federal Union must be preserved."

The troops which have entered the United States' service from New Hampshire amount to 18,261. Of these, one regiment volunteered under the first call for troops in April, 1861; seven regiments of infantry, one battery, three companies of sharpshooters, four companies of cavalry, and several small detachments volunteered under the call made in July, 1861. Under the call in July, 1862, for three years, six regiments of infantry volunteered, and

under the call for nine months, three regiments entered the service.

The receipts into the State Treasury for the year ending June 1, 1862, with the balance of the former year on hand, were \$190,649. The expenditures for civil purposes, during the same period, were \$172,685. The expenditure of the State for war purposes, up to the same period, was \$958,649.

The length of railroads within the limits of the State is about 656 miles, and the cost of construction over \$28,268,659.

The institutions for education in the State consist of Dartmouth College, with which is connected a medical and a scientific school. There are also three theological institutions in the State; one at Gilmanton (Congregational), one at New Hampton (Free Will Baptist), and one at Concord (Methodist Episcopal). There are in the State 2,352 common-school districts, and the number of children attending school, 44,787. The amount raised by tax for the support of schools during the year was \$239,014. From other sources sufficient was contributed to make the total amount \$274,628. The number of incorporated academies in the State is seventy-three.

**NEW JERSEY.** The population of the State of New Jersey, according to the national census of 1860, was, distinguishing the leading cities, as follows:

CITIES.	Population.		Increase.	Per cent.
	1850.	1860.		
Burlington....	4,586	5,198	657	14.46
Jersey City...	6,856	29,226	22,370	326.28
Newark.....	88,894	71,914	38,020	84.89
Paterson.....	11,384	19,588	8,254	72.68
Total.....	61,620	125,921	64,301	102.70
Rest of State..	427,985	520,778	92,848	21.50
Total.....	489,555	646,699	167,144	37.37

The number of dwellings in this State was 108,144, or 1.09 to each family of 5.7 persons. The number of males 322,732, of females 323,966. There were 25,318 free blacks, and 18 slaves.

The further returns of the census of 1860 will be found under UNITED STATES.

The political character of the State Government was changed during the year 1862. A considerable sensation was produced by the arbitrary arrest of James R. Wall and his incarceration in a Government prison out of the State. The people, while refraining from every form of open opposition to the Government, expressed their strong disapprobation of this action by the subsequent election of Mr. Wall to fill a vacancy in the United States Senate.

The State election is held on the 1st Tuesday of November. The election in 1862 was for State officers, members of Congress, one third of the Senate, and all of the House in the State Legislature. The voters of the State were divided into two parties, the democrats and the republicans.

The republican, or, as it was called, the

"people's convention," assembled at Trenton in the month of July, and nominated Marcus L. Ward for governor, and adopted the following resolutions, as expressive of the views of the convention on national affairs :

*Whereas*, this convention has assembled to nominate to the people of New Jersey a candidate for the office of governor; to be chosen by their suffrages at the ensuing election; and whereas, the delegates now met for this purpose, at a crisis in our history grave and momentous beyond all example, have been appointed to this duty upon a public and general call to all the citizens of the State who, forgetful of past party distinctions and divided opinions, are united in the sincere, unqualified purpose to support to their utmost ability the National Government in its policy, and its efforts to crush the rebellion, to maintain the Constitution, to preserve the American Union, and to restore order and peace to the land; therefore,

*Resolved*, That discarding all personal, partisan views, looking solely to the welfare and duty of the State, whether separately by itself, or as vitally and inseparably a part of the Union, we believe we shall best and most surely secure and fulfil them by aiming to continue in the highest executive office of our State the same principles, policy, and conduct that have marked with admirable distinction the executive term now drawing to its close; that in reviewing the vigilance, the fidelity, and the wisdom with which its duties have been discharged—the ready and vigorous responses to the requisitions of the country and the war, and the confidence inspired by its general course among ourselves and abroad, we find with grateful satisfaction the character and qualities peculiarly fitted for the exigencies of the place and the times.

*Resolved*, That the foremost and paramount duty of the General Government, of the States, and of the people, is to devote their utmost energies, their resources, and their lives, the most effectually and forever to subdue the rebellion now raised against the Government, the liberties, and the life of the nation; that everything in the origin and the progress of this rebellion—the vindictive pride and disappointed ambition that engendered it—the false and insidious political teachings that quickened it into birth—the delusive pretexis and cunning acts that stimulated its growth, and the lawless passions that, reckless of reason, justice, and of oaths, forced its first violent outburst upon the deluded and misguided millions now drawn under its power, all stamp it the most causeless, wicked, and infamous ever known among men.

*Resolved*, That the disruption, the dismemberment, or the new formation of this nation, are not subjects submitted to the discretion or choice of our people; that the causes and powers conspicuously seen through more than two hundred years, in every period of our being, determining our destiny, shaping and guiding and compacting our growth, are before and superior to such discretion or choice, and exact by inevitable law the concurrence and coöperation of both; that the influences, the agencies, and the conditions, varied and marvellous as they were, by which, in all the eras of our history, colonial, revolutionary, and constitutional, the hand of a beneficent Divinity formed and developed our national proportions and life, assure us by infallible proofs that they must be nurtured and preserved as they were bestowed, and that all efforts to divide or refashion them—alike impious and vain—must end in anarchy and remediless national decay.

*Resolved*, That as citizens of New Jersey we are bound to the maintenance of the Constitution and the Union by obligations of duty, of interest, of affection, and of honor, as sacred, as indissoluble at the least as can belong to any other of the sisterhood of States. Proved and experienced by us as the sources and security of all earthly good—consecrated by the sacrifices, the sufferings, and the heroisms of the past, we are bound to spare nothing upon earth to transmit them unimpaired to our children and generations to come.

*Resolved*, That the principles adopted and the objects pursued by the President and his Administration in the conduct of the war, and in the general management of our national affairs, command our entire and cordial approval; that in the confidence, unabated and increasing, reposed without distinction of party by the loyal millions of our countrymen, in the fidelity, wisdom, firmness, and patriotism displayed in their policy and course, we find the strongest grounds of encouragement, and the most auspicious omens of the future; and that, standing as they now do on the eve of the great and final events which must result in the overthrow of rebellion, or in the utter ruin of the country, and clothed as they now are with all the powers that can be conferred by legislation, and all the instruments of war that can be furnished by the people, it is the imperative duty of the Administration to exercise all those powers, and to wield all those instruments with the most unflinching and uniform vigor, until the end shall be attained, in the absolute and universal supremacy of the Government; that their prompt and fearless discharge of that duty is demanded alike by the popular instinct of self-preservation, and by the simplest obligations of their official position; and being fully assured that they cannot in this direction outrun public sentiment, we demand that they shall keep pace with it.

*Resolved*, That with rebellion existing in our land, foreign governments have nothing to do—and that against all intervention by them we will wage a war as persistent and uncompromising as against the rebellion itself.

*Resolved*, That our lasting gratitude is due to the generals, the officers, and soldiers of our armies from our own and sister States, by whose bravery and skill so many victories have been won.

The democratic convention assembled at Trenton in September, and nominated Joel Parker for governor, and adopted the following resolutions as expressing the views of the convention :

*Whereas*, the democracy of New Jersey have again assembled in convention, to exercise the right of freemen to nominate a candidate for the highest office in the gift of the people; and whereas, we hold that popular conventions alone may rightfully proclaim the tenets of the party; therefore,

*Resolved*, That deploring the demoralizing tendency of the higher law teachings of the republican party, we feel impelled to reiterate our faith in the doctrine that constitutional law is the only true basis of executive action in peace or war.

2. That in the present exigencies of the country we extend to the National Administration our most cordial support for the suppression of the rebellion by all constitutional means, and that the party stands, as it has ever stood since the formation of the Government, for the Union, the Constitution, and enforcement of the laws.

3. That as in establishing the Constitution the people reserve to themselves all powers not delegated to the Government, therefore all assumptions of power by the Administration, whether in the suspension of the writ of *habeas corpus*, arrests and imprisonments without due course of law, or restrictions of freedom of speech and of the press, are dangerous infringements of the constitutional rights of the people, only to be patiently borne by the hopeless serfs of an irresistible despotism.

4. That, while we enter our solemn protest against the reckless extravagance, infamous speculation, and political outrages of which the party in power is guilty, and while we deprecate the horrors of the civil conflict now raging, we still hold it our duty to advocate the use of every constitutional means to the extent of the full power of the Government, for the suppression of the rebellion, the vindication of the authority of the "Constitution as it is, and the restoration of the Union as it was."

5. That we do entirely reject and abhor the idea, that, as an object of the present civil war, any purpose of emancipation of the slaves shall be thereby promoted or at all regarded; and that the language recently used in the Washington "Republican," "that the farce of restoring the Union of the States is about played out," is utterly infamous, and deserving, as it will receive, the most solemn and severe condemnation of all true patriots.

6. That we applaud our brave volunteers, who by their gallant deeds have emulated the heroism of the old "Jersey Blues," and that we extend our heartfelt sympathy to those who are bereaved by the calamities of the war.

7. That to the candidate this day nominated we pledge our entire support, believing that the political triumph of the Constitutional Democracy in the coming elections, will have a powerful effect in terminating the rebellion, and reestablishing peace, prosperity, and happiness throughout the land.

The votes of the electors were cast as follows:

	Democrat.	Republican.
For Governor.....	61,807	46,710

The majority of the democratic candidate was 14,597.

The votes for members of Congress were cast as follows:

	Democrat.	Republican.
1st district.....	8,991	9,491
2d " .....	12,159	10,384
3d " .....	15,708	9,098
4th " .....	12,791	10,024
5th " .....	10,779	7,622

The Legislature was divided as follows:

	Senate.	House.
Democrats.....	18	45
Republicans .....	8	15

The Senate consists of 21 members, and the House of 60. The Legislature meets annually at Trenton on the second Tuesday in January.

The measures of the Legislature were almost entirely of a local nature. A bill was under consideration to forbid the immigration of negroes into the State, but it failed to become a law, although there are more free colored people in the State in proportion to the population than in any other non-slaveholding State.

Under the call for troops in 1861 the State of New Jersey was among the foremost to respond with her full quotas. She sent forward 15 regiments, and two batteries, numbering 14,870 men. These regiments lost heavily, and the events toward the close of that year caused the regiments to fall into a somewhat demoralized condition; and on the 29th of January an order was issued from the War Department, placing these regiments under the State authorities. Prompt measures were adopted to reorganize the troops under State officers, and an efficient condition was soon reached. The 1st cavalry was placed under Col. Percy Wyndham, and became very effective. On the 7th of July, under the call of the President, for 300,000 three years' men, five regiments were required from New Jersey. There was but one regiment in camp, and recruiting was dull. It was determined to establish five camps in the State under different officers, as follows:

No. 1.—Trenton.....	Brig.-Gen. N. N. Halsted.
No. 2.—Beverly.....	" " G. M. Robeson.
No. 3.—Freehold.....	" " Chas. Haight.
No. 4.—Newark.....	" " Com. Van Vorst.
No. 5.—Flemington....	" " A. E. Donaldson.

An order was issued providing for the payment of \$2 premium for each recruit, one month's pay and \$25 dollars in advance of the \$100 provided for by Congress for three years' service. There was also the bounty paid of \$6 by the State to each family monthly, and from \$2 to \$4 to single men. A second lieutenant was appointed for each company to act as mustering officer. Each recruit as he appeared in camp received his money, was uniformed and put to drill. By this means the five regiments were filled in a month.

	Mustered in.	Strength.	Left the State.	Colonels.
11th..	Aug. 18.	907	Aug. 25.	R. McAllister.
13th..	Sept. 4.	979	Aug. 28.	R. C. Johnson.
18th..	Aug. 25.	880	Sept. 1.	E. A. Carman.
14th..	Aug. 26.	984	Sept. 5.	W. S. Truex.
15th..	Aug. 25.	914	Sept. 6.	Samuel Fowler.
		4,644		

Each regiment had 89 officers; there were consequently 4,248 enlisted men. Some of these regiments went immediately into action. The 13th left the State on the 1st, and on the 17th, at Antietam, lost 109 killed, wounded, and missing.

Under the President's call, August 4th, for 300,000 nine months' men, an enrollment took place of all citizens from 18 to 45 years of age. The quota of New Jersey under this call was 10,478 men. On the 14th of August an order from the War Department directed a draft to be made on the 8d of September. The commissioners, surgeons, and enrolling officers in each county were appointed, and the local quotas ready for publication, when an order was issued that counties should have credit for the volunteers before furnished. This order led to great complications. The quotas were finally ascertained by adding to the whole number of volunteers furnished by the State the number of men required by the new call. From the number thus resulting to each township was taken the number already furnished. It was then ordered that volunteers in lieu of drafted men would be taken up to September 1st. The recruits then flocked into the camps, and on September 2nd the five camps contained 10,800 men, which by medical examination was reduced to 10,714, or 236 more than the number called for. The 10,714 men were organized into 11 regiments as follows, including officers:

	Mustered in.	Strength.	Left the State.	Colonels.
21st.	Sept. 15.	966	Sept. 24.	G. Van Houten.
22d..	" 22.	987	" 29.	Com. Fornet.
23d..	" 18.	994	" 26.	J. S. Cox.
24th.	" 16.	985	" 29.	W. B. Robertson.
25th.	" 29.	984	Oct. 10.	A. Derron.
26th.	" 18.	958	Sept. 26.	A. J. Morrison.
27th.	" 19.	1,014	Oct. 10.	Geo. W. Mindil.
28th.	" 15.	920	" 3.	M. N. Wisewell.
29th.	" 20.	949	Sept. 28.	E. F. Applegate.
30th.	" 17.	1,006	" 30.	A. E. Donaldson.
31st.	" 17.	1,001	" 26.	A. P. Berthons.
		11,814		

The field and line officers were elected under the constitutional State militia law. All these regiments were in the army of the Potomac,

and four were engaged in the battle of the Rapahannock, December 18th. Under all the requisitions the State furnished the following troops:

REQUISITIONS.	Minimum.	Maximum.	Furnished.
1st—4 regiments militia....	3,128	3,128	3,105
2d—3 regiments volunteers.	2,598	3,188	3,120
3d—5 regiments volunteers.	4,880	5,280	7,601
4th—5 regiments volunteers	4,880	5,280	4,644
5th—Draft .....	10,478	10,478	10,714
Recruits .....	....	....	1,030
Total.....	24,969	27,199	30,214
8 months' men disbanded.....			3,105
Died, &c., in 1861.....			389
Died, &c., in 1862.....			3,678—7,173
In service January, 1863.....			23,049

A call for 8,000 men, to fill up the old regiments, was not filled, only 1,030 men having been raised for that purpose, although the State furnished more than that amount over all the quotas. The men have a great repugnance to old regiments.

The number enlisted in regiments of other States, it is estimated, carries the total to 35,000.

Of the number in service, 10,373 left families or dependent mothers. The State bounty to them, at \$6, amounts to \$746,856 per annum. Of single men 12,669 draw an average of \$2½ per month, making \$380,070. The annual charge to the State is therefore \$1,126,926.

The number of men now liable to military duty is 71,697 in the State.

The State debt at the beginning of the year was about \$770,000, of which \$100,000 is payable annually. Excepting \$95,000 it was all contracted for war purposes. A tax to defray State expenses had been unknown for some years previous to the commencement of the war. The taxes for local purposes in 1860 amounted to \$1,319,299.

There are three colleges in the State, and two theological seminaries. The State appropriation for public schools exceeds \$600,000, in addition to which there is in many cities and towns a local tax of two mills or less on the dollar. The number of school districts 1,563. There is also a State normal school for the education of teachers.

The miles of railroad in the State are 560, and the cost of construction \$28,997,033.

NEW ORLEANS, OCCUPATION OF. On May 1, 1862, several days after the surrender of the city to Flag Officer Farragut, formal possession was taken of New Orleans by the land forces of the United States under the command of Maj.-Gen. B. F. Butler, who, after a conference with the municipal authorities and some of the principal inhabitants, issued a proclamation adapted to the circumstances of the captured city and its inhabitants. After assuring protection to all well disposed persons, natives as well as foreigners, and requiring keepers of public property and manufacturers of arms and munitions of war to make a return of the kind and quantity

of material in their possession, the proclamation proceeded as follows:

All the rights of property of whatever kind will be held inviolate, subject only to the laws of the United States. All the inhabitants are enjoined to pursue their usual avocations. All shops and places of amusement are to be kept open in the accustomed manner, and services are to be held in the churches and religious houses, as in times of profound peace. Keepers of all public houses and drinking saloons are to report their names and numbers to the office of the Provost Marshal, and they will then receive a license, and be held responsible for all disorders and disturbances arising in their respective places. Sufficient force will be kept in the city to preserve order and maintain the laws. The killing of American soldiers by any disorderly person or mob is simply assassination and murder, and not war, and will be so regarded and punished. The owner of any house in which such murder shall be committed will be held responsible therefor, and the house be liable to be destroyed by the military authority. All disorders, disturbances of the peace, and crimes of an aggravated nature, interfering with the forces or laws of the United States, will be referred to a military court for trial and punishment. Other misdemeanors will be subject to the municipal authority, if it desires to act. Civil causes between party and party will be referred to the ordinary tribunals. The levy and collection of taxes, save those imposed by the laws of the United States, are suppressed, except those for keeping in repair and lighting the streets and for sanitary purposes. These are to be collected in the usual manner. The circulation of Confederate bonds, evidences of debt (except notes in the similitude of bank notes), issued by the Confederate States, or scrip, or any trade in the same, is forbidden. It has been represented to the Commanding General by the civil authorities that these Confederate notes, in the form of bank notes, in a great measure, are the only substitutes for money which the people have been allowed to have, and that great distress would ensue among the poorer classes if the circulation of such notes should be suppressed. Such circulation, therefore, will be permitted so long as any one will be inconsiderate enough to receive them until further orders. No publication of newspapers, pamphlets or handbills giving accounts of the movements of the soldiers of the United States within this department, reflecting in any way upon the United States, intending in any way to influence the public mind against the United States, will be permitted, and all articles on war news, editorial comments, or correspondence making comments upon the movements of the armies of the United States, must be submitted to the examination of an officer who will be detailed for that purpose from these headquarters. The transmission of all communications by telegraph will be under the charge of an officer from these headquarters.

Gen. Butler further requested that outrages committed by the soldiery upon the persons or property of citizens should be reported to the provost guard, prohibited the assemblage of persons in the streets, suspended the municipal authority so far as the police of the city and crimes were concerned (except that for the effective promotion of order an armed body of foreigners known as the European Legion, which was employed subsequent to the evacuation of the city by Gen. Lovell to protect the lives and property of the citizens, was invited to cooperate with the military authorities), and in general imposed upon the city the ordinary conditions of martial law. Copies of the proclamation were sent to all the newspaper offices; and upon the editors unanimously refusing to print it, forcible possession was taken of the

"True Delta" office, and by the aid of Northern printers, selected from the different regiments of national troops, the document was speedily set up, and was worked off in the edition of the paper for May 2.

The landing of troops at New Orleans and at Algiers, on the opposite side of the Mississippi, meanwhile went vigorously on, and, by the direction of Gen. Shipley, the military governor, the principal points of approach to the city were occupied in force, with pickets thrown out as far as the crossing of the Jackson and Jefferson railroad. Gen. Butler established his headquarters at the St. Charles hotel, and another large hotel, the Evans House, on Poydras street, was converted into a hospital. A sufficient force of gunboats remained in front of the city to oppose any sudden rising of the inhabitants or attack by a Confederate army, while the remainder with a portion of the mortar fleet proceeded up the river to Catrolton, Baton Rouge, and other places. Whether, on account of the hopelessness of opposition, or of the indifference with which the large foreign element in the population (about 40 per cent.) regarded the fate of the city, or because perhaps the inhabitants were satisfied with the immense destruction of cotton and sugar which had already been accomplished, the city remained comparatively tranquil. "Our streets," says the "Delta" of May 1, "are remarkably quiet. Most of the stores have been closed since Friday last (April 25), and remain closed, with a few exceptions. The principal hotels are closed, and there is some difficulty among those who have been in the habit of making these establishments their homes in effecting other arrangements. The bar rooms have all been closed since Friday last. For some days there was great difficulty in passing the miserable currency we are cursed with, but, thanks to the judicious measures taken by the authorities, confidence in it has been partially restored. The markets are still very meagrely furnished, and, to provide regular supplies of food for this large population, will require all the wisdom of those who have our welfare in their keeping, for the ordinary intercourse between the city and country must, to a considerable extent, continue broken up.

\* \* \* \* \*

"The movements in financial circles during the past week have been of the most restricted character ever witnessed in the Crescent City. The banks kept their doors open for a few hours daily to pay depositors' checks and renew maturing obligations; but they peremptorily refused to receive deposits or transact any other kind of business. Their presidents also held one or more informal meetings with the view of adopting some uniform policy in their future management; but no definite conclusion was arrived at, and each one is still at liberty to adopt such action as circumstances may suggest."

The first consideration brought to the notice of the military and municipal authorities was

the destitute condition of a large portion of the population, who were literally at the point of starvation; and in accordance with a recommendation from the mayor and common council Gen. Butler gave orders, on May 2 and 3, for the safe conduct of cargoes of flour, live stock, and other necessaries from Mobile and various places in the interior. These proving ineffectual to relieve the prevailing distress, he issued on the 9th of the month a proclamation, known as General Order No. 25, the purport of which can be best understood by quoting the document in full:

HEADQUARTERS, DEPARTMENT OF THE GULF, }  
NEW ORLEANS, May 9, 1863. }

The deplorable state of destitution and hunger of the mechanics and working classes in this city has been brought to the knowledge of the Commanding General.

He has yielded to every suggestion made by the city government, and ordered every method of furnishing food to the people of New Orleans that that government desired. No relief by those officials has yet been afforded. This hunger does not pinch the wealthy and influential, the leaders of the rebellion, who have gotten up this war, and are now endeavoring to prosecute it, without regard to the starving poor, the working man, his wife and child. Unmindful of their suffering fellow citizens at home, they have caused or suffered provisions to be carried out of the city for the Confederate service since the occupation by the United States forces.

Lafayette square, their home of affluence, was made the depot of stores and munitions of war for the rebel armies, and not of provisions for their poor neighbors. Striking hands with the vile, the gambler, the idler and the ruffian, they have destroyed the sugar and cotton which might have been exchanged for food for the industrious and good, and regrated the price of that which is left, by discrediting the very currency they had furnished while they sloped with the specie, as well as that stolen from the United States, as the banks, the property of the good people of New Orleans, thus leaving them to ruin and starvation—fugitives from justice many of them, and others, their associates, staying because too puerile and insignificant to be objects of punishment by the clement Government of the United States.

They have betrayed their country.

They have been false to every trust.

They have shown themselves incapable of defending the State they have seized upon, although they have forced every poor man's child into their service as soldiers for that purpose, while they made their sons and nephews officers.

They cannot protect those whom they have ruined, but have left them to the mercies and assassinations of a chronic mob.

They will not feed those whom they are starving.

Mostly without property themselves, they have plundered, stolen, and destroyed the means of those who had property, leaving children penniless and old age hopeless.

Men of Louisiana, working men, property holders, merchants and citizens of the United States, of whatever nation you may have had birth, how long will you uphold these flagrant wrongs, and by inaction suffer yourselves to be made the serfs of these leaders?

The United States have sent land and naval forces here to fight and subdue rebellious armies in array against her authority. We find, substantially, only fugitive masses, runaway property owners, a whiskey-drinking mob, and starving citizens with their wives and children. It is our duty to call back the first, to punish the second, root out the third, feed and protect the last.

Ready only for what we had not prepared ourselves,

to feed the hungry and relieve the distressed with provisions. But to the extent possible within the power of the Commanding General it shall be done.

He has captured a quantity of beef and sugar intended for the rebels in the field. A thousand barrels of those stores will be distributed among the deserving poor of this city, from whom the rebels had plundered it; even although some of the food will go to supply the craving wants of the wives and children of those now herding at Camp Moore and elsewhere, in arms against the United States.

Capt. John Clark, Acting Chief Commissary of Subsistence, will be charged with the execution of this order, and will give public notice of the place and manner of distribution, which will be arranged as far as possible so that the unworthy and dissolute will not share its benefits.

By command of Major-General BUTLER,  
Geo. C. Strong, Assistant Adjt.-Gen., Chief of Staff.

In accordance with this proclamation, a public distribution of the captured stores was commenced on the 18th, by which means, together with the subsequent revival of traffic, all apprehensions of immediate distress were dispelled. In reply to the severe strictures of Gen. Butler, several of the city newspapers in the Confederate interest stated, that since the preceding August the poor had been gratuitously supplied twice a week with provisions, that millions of dollars had been subscribed by private individuals for similar purposes, and that the existing suffering was due to two causes: first, the blockade, or non-intercourse with the country from which provisions had previously been drawn, and, secondly, the derangement of the currency, the United States commander having, in his proclamation, warned the people of the danger of receiving the only currency in circulation, or rather the basis of the only currency in circulation.

With a view to procure a remedy for the latter evil, a committee of the Associated Banks of New Orleans requested permission to restore to their vaults the specie which had been conveyed from the city previous to its occupation by the national forces; to which Gen. Butler replied that the specie should have safe conduct through his lines and be protected, so long as it should be used in good faith to make good the obligations of the banks to their creditors by bills and deposits. "In order," he added, "that there may be no misunderstanding, it must be further observed that I by no means pledge myself that the banks, like other persons, shall not return to the United States authorities all the property of the United States which they may have received. I came to 'retake, repossess, and occupy all and singular the property of the United States of whatever name and nature. Further than that I shall not go, save upon the most urgent military necessity.'"

Acting in the spirit of these words, Gen. Butler had on the 10th of the month taken forcible possession of a large amount of specie deposited in the office of M. Conturié, consul of the Netherlands, and which, it was supposed, belonged to the Confederate Government, or was to be expended in their behalf. The proceeding drew forth a formal protest from

the entire consular body of New Orleans, as being in contravention of treaties between their governments and the United States. In reply Gen. Butler expressed his regret that the consuls should have acted without investigating the facts of the case, and stated that it would be demonstrated at the proper time, that the flag of the Netherlands had been used to cover and conceal property of an incorporated company of Louisiana, secreted under it, from the operation of the laws of the United States. "No person," he concluded, "can exceed me in the respect I shall pay to the flags of all nations and to the consular authority, even while I do not recognize many claims made under them; but I wish it to be most distinctly understood, that, in order to be respected, the consul, his office, and the use of his flag, must each and all be respected."

The rigor and decision which marked Gen. Butler's conduct in this instance characterized his administration from the moment of his arrival in New Orleans, and by a prompt and sometimes severe exercise of the rules of martial law, particularly in the matter of arrests and imprisonments, he kept the city in an orderly condition, although the inhabitants, distrusting his ability to maintain his authority for any considerable period, at first manifested no enthusiasm at the restoration of the national supremacy, and carefully abstained from committing themselves in favor of the Union. A notable exception was found in the conduct of a portion of the female population, who availed themselves of the license usually permitted to their sex, to offer gross insults and indignities to the national soldiers while in the orderly discharge of their duties. Apprehending that, if this conduct should be unrebuked, the soldiery might be induced to retaliate, or brought into such contempt as to provoke open assaults from the disaffected portions of the populace, Gen. Butler issued on May 15 the following order, known as General Order No. 28:

HEADQUARTERS, DEPARTMENT OF GULF, NEW ORLEANS.

As officers and soldiers of the United States have been subject to repeated insults from women, calling themselves ladies, of New Orleans, in return for the most scrupulous non-interference and courtesy on our part, it is ordered hereafter, when any female shall by mere gesture or movement insult, or show contempt for any officers or soldiers of the United States, she shall be regarded and held liable to be treated as a woman about town plying her avocation.

By command of Major-General BUTLER.

Its publication excited violent opposition from disloyal citizens, and the mayor of the city, John T. Monroe, made it the subject of an angry communication to the municipal government, and of a letter to Gen. Butler, placing an exceedingly offensive construction upon the order. The latter immediately directed him to be deprived of his official functions, and committed to Fort Jackson until further orders. At a subsequent interview with the commander-in-chief, at headquarters, the mayor was

informed that a withdrawal of his letter, and an apology for the language which it contained, would alone relieve him from incarceration; whereupon he made the annexed apology and retraction, and was allowed to resume the functions of his office:

GEN. BUTLER: This communication, having been sent under a mistake of fact, and being improper in language, I desire to apologize for the same, and to withdraw it.

JOHN T. MONROE, Mayor.

May 16, 1862.

In explanation of the meaning and intent of the order, Gen. Butler, at the same time, addressed the following letter to the mayor, which was published together with the apology of the latter, in the daily papers of New Orleans:

HEADQUARTERS, DEPARTMENT OF THE GULF. }  
NEW ORLEANS, May 16, 1862. }

SIR: There can be, there has been, no room for misunderstanding of General Order No. 28.

No lady will take any notice of a strange gentleman, and a *fortiori* of a stranger, simply in such form as to attract attention. Common women do.

Therefore, whatever woman, lady or mistress, gentle or simple, who, by gesture, look, or word, insults, shows contempt for, thus attracting to herself the notice of my officers and soldiers, will be deemed to act as becomes her vocation as a common woman, and will be liable to be treated accordingly. This was most fully explained to you at my office.

I shall not, as I have not, abated a single word of that order; it was well considered; if obeyed, will protect the true and modest women from all possible insult. The others will take care of themselves.

You can publish your letter, if you publish this note and your apology. Respectfully,

BENJ. F. BUTLER,

Major-General Commanding.

JOHN T. MONROE, Mayor of New Orleans.

The agitation consequent upon the publication of Order No. 28 was not confined to New Orleans or its neighborhood, but throughout all the States, loyal and disloyal, the language of Gen. Butler was made the subject of comments varying with the feelings or circumstances of the writer. Gen. Beauregard read it at the head of his army, as an incitement to renewed efforts against the "Northern hordes;" the Confederate journals denounced it with all the resources of the language at their command; and even in the North many editors and public speakers expressed themselves strongly against the order, and called upon the President to disavow it publicly and rebuke its author. In the European journals unfriendly to the national cause, and in some also of opposite views, it was criticized with characteristic asperity. The order was nevertheless tolerated by the President, and, in spite of the obloquy sought to be associated with it, was, in the opinion of persons competent to judge, in no respect oppressive in its operation, but rather productive of substantial good by preventing an indulgence in wanton insults, by any class of the population. In a private letter written in July, Gen. Butler has given the following account of his motives in acting as he did, and of the presumed necessity for such action:

What was the state of things to which the woman order applied?

We were two thousand five hundred men in a city seven miles long by two to four wide, of a hundred and fifty thousand inhabitants, all hostile, bitter, defiant, explosive, standing literally on a magazine; a spark only needed for destruction. The devil had entered the hearts of the women of this town (you know seven of them chose Mary Magdalen for a residence) to stir up strife in every way possible. Every opprobrious epithet, every insulting gesture was made by these bejewelled, becrinolined, and laced creatures, calling themselves ladies, toward my soldiers and officers, from the windows of houses and in the streets. How long do you suppose our flesh and blood could have stood this without retort?

That would lead to disturbances and riot; from which we must clear the streets with artillery—and then a howl that we murdered these fine women. I had arrested the men who hurrahed for Beauregard. Could I arrest the women? No. What was to be done? No order could be made, save one, that would execute itself. With anxious, careful thought I hit upon this: "Women who insult my soldiers are to be regarded and treated as common women plying their vocation."

Pray how do you treat a common woman plying her vocation in the streets? You pass her by unheeded. She cannot insult you! As a gentleman you can and will take no notice of her. If she speaks, her words are not opprobrious. It is only when she becomes a continuous and positive nuisance that you call a watchman and give her in charge to him.

Why, these she adds of New Orleans themselves were at once shamed into propriety of conduct by the order, and from that day no woman has either insulted or annoyed any live soldier or officer, and of a certainty no soldier has insulted any woman.

When I passed through Baltimore, on the 23d of February last, members of my staff were insulted by the gestures of the ladies (?) there. Not so in New Orleans.

I can only say, I would issue it again under like circumstances.

On May 29, the further circulation of Confederate money, which had been permitted for a limited period, ceased, in accordance with an order from the commander-in-chief, and on June 1, the port of New Orleans was declared, by a proclamation of the President, again open to commerce. Charles L. Lathrop, a former resident of the city, was appointed collector, and steam communication was almost immediately resumed with the Northern States. So beneficial were the results of reviving commerce and of the strict attention to police and sanitary measures which was exacted, that the "Delta" of June 1, commenting upon the sullen and deserted aspect of the city at the entrance of the national troops, observed:

One short month has elapsed. The streets are filled with smiling faces, business attracts with open doors, thugs have left for summer watering places, property is secure, and Abraham Lincoln, by the grace of God and the electoral vote of the people President of the United States of America, might walk, unarmed and unaccompanied, at any time through these streets, in full security, and to the joy and delight of numbers who have heretofore been accustomed to link his name with curses and execrations.

This change was not effected without a resort to measures which were denounced as arbitrary and tyrannical. Arrests of suspected persons had constantly to be made, at the dis-

cretion of the commander-in-chief, including among others, Pierre Soulé, who was sent North; the "thugs," gamblers, and other desperate characters who had long dominated in the city, were dispersed or intimidated into silence; the newspapers were on one occasion temporarily suppressed for advocating the burning of cotton and produce; and the bakers and other vendors of food, who had taken advantage of the scarcity of provisions to charge exorbitant prices, were compelled to conform to the tariff fixed by the city ordinances. For the further protection of the citizens, stringent orders were issued on May 27, and June 5, prohibiting officers and soldiers from taking private property or forcibly entering and searching private dwellings without written authority from the proper officers.

On June 7, took place the first military execution since the occupation of the city, the sufferer being one William B. Mumford, who was arrested for hauling down, on the morning of April 26, an American flag hoisted on the mint by a boat's crew from Flag Officer Farragut's fleet, and subsequently assisting in tearing it into shreds, and otherwise insulting it in the presence of a large and riotous crowd of citizens. The act, if unnoticed, was deemed to offer so pernicious a precedent for future offences, that Mumford was directed to be tried before a military commission, by whom he was convicted and sentenced to be hung. The sentence was approved by Gen. Butler, and carried into effect in the presence of an immense throng of citizens, who made no demonstration and dispersed quietly to their homes. A universal cry of indignation at what was denounced as an act of murder went up from the seceded States, the hoisting of the flag, pending the formal surrender of the city, being deemed an unauthorized and unjustifiable proceeding on the part of the United States authorities, and one against which the mayor had protested in a written communication to Flag Officer Farragut. On the other hand, it was claimed that the flag had been hoisted on a public building of the United States, and that the tearing of it down was an overt act of treason, done for the purpose of exciting other evil-minded persons to further resistance to the laws and arms of the United States.

To the deep feeling of revenge which this execution aroused was due the vindictive retaliatory order subsequently issued by Jefferson Davis, and the rewards for the assassination of Gen. Butler, which have from time to time appeared in the Southern papers. The clemency of Gen. Butler had, however, a few days previous, been successfully invoked in favor of six Confederate soldiers paroled at Fort Jackson, and subsequently sentenced by a court martial to be shot for being engaged in a conspiracy to raise a company to serve in Gen. Beauregard's army; and on another occasion he manifested his desire to administer justice impartially, by causing sentence

of death against two soldiers of the garrison, convicted of robbery by a court martial, to be carried into effect. These were the only military executions which have taken place in New Orleans during its occupation by the national forces.

In a speech delivered in Philadelphia, after his return from New Orleans, Gen. Butler defended the course pursued by the military authorities in the case of Mumford. Referring to the indignity offered by him to the American flag, he said :

That act, in its consequences, might have been most calamitous. The commander of the Federal fleet and the army, then coming up the river, had a right to suppose that the city authorities had come to the conclusion to renew the contest, and the evidence of that renewal was the hauling down of the flag. The commander of the fleet had no means of knowing that this was done by a mob, and the act might and ought, as a military proposition, to have brought down upon the city an instant bombardment. But, through the very proper precaution of Commander Farragut, but a shot or two were fired, and, no resistance following, no special damage was done, it resulting in the wounding of a single person.

But, mark you, sir, it was not the fault of Mumford that New Orleans was not laid in ashes, and the women and children crushed beneath the shells of the Federal fleet. We were about taking other towns and cities on the Mississippi river. If every drunken ruffian, by tearing down our flag, could bring bombardment upon every city along the Mississippi river, there was no safety to the non-combatants from the operations of war, nor in the surrender of places. And it was in mercy to the towns that we should take hereafter, and their inhabitants, that I felt it necessary to punish, according to the just laws of war, after a fair trial and full confession of guilt, William B. Mumford. To save human life and ameliorate the horrors of war, it became necessary exemplarily to punish this crime. I have a right to say here that, in no unauthorized manner, in the Department of the Gulf, has any other flag of the nation been taken from the place where it has been put by loyal hands. And whether rightfully or wrongfully done, that act still commends itself to my judgment.

And seeing the utter worthlessness of the man that treason has attempted to exalt into a patriot, I was inclined to spare Mumford, but that was not permitted to me. His associates, the thugs, roughs, rowdies, and gamblers, assembled in New Orleans on the night before his execution, and solemnly voted that Mumford should not be executed. It then became a question whether the mob should rule New Orleans, as it had done for fifteen years previously, or the commanding general of the United States forces. From that day, however, there has never been any question on that subject.

The difficulties with which Gen. Butler had become involved at the very outset of his administration, with the foreign consuls in New Orleans, foreshadowed a long series of complications with that body, embodying several grave questions of international comity. The news of the proceeding in the case of the consul of the Netherlands made some stir in the Northern States, and the subject having been brought to the notice of Mr. Seward by the British minister in the latter part of May, orders were issued from the War Department directing Gen. Butler to refrain from practising any severities or strictness of doubtful right toward consuls or the subjects of any foreign



power. M. Mercier also laid before the Secretary of State the substance of a letter from Count Mejan, the French consul at New Orleans, who complained that domiciliary visits, without the authority of written orders, were made at all hours of the day and night; that arbitrary arrests and imprisonments were frequent and unseasonable; and that several keepers of bars, restaurants, billiard rooms, and similar establishments, had been compelled by Gen. Butler, who claimed to act by virtue of martial law, to take out annual licenses in addition to those previously paid by them. In view of these representations, the Hon. Reverdy Johnson was early in June appointed a special commissioner to proceed to New Orleans and inquire into the transactions, involving any question of the violation of consular privileges, which had taken place there, and to report his decision to the Government.

The case of M. Contarié was the most important which came under Mr. Johnson's notice, and soon after his arrival in New Orleans a complaint was preferred by the French consul that he had been interrogated by Gen. Butler with respect to a large amount of coin deposited at the consulate for safe keeping, and had been compelled to promise not to part with it until the matter could be investigated. As both transactions were similar in character, they were examined together, and the following statement of facts was reported by the commissioner:

The sum in the hands of the consul of the Netherlands, amounting to \$800,000, was, under a resolution of the Board of Directors of the Citizens' Bank of New Orleans, of Feb. 24, 1862, paid to Mr. Edward J. Forstall of that city, the agent of Messrs. Hope & Co. of Amsterdam, to be transmitted at the first opportunity to that house, to enable it to protect the credit of the bank and of the State of Louisiana, by paying, as it accrued, the interest on certain bonds of the State, long before loaned to the bank, under an agreement that, before disposing of them, the bank should indorse them, and stipulate to meet punctually the interest and principal. The bonds were negotiated in Europe many years since by the bank, through the agency of the Amsterdam house, and the interest that had fallen due from time to time, up to the period of the advance to Mr. Forstall, had been regularly paid through the same agency. Mr. Forstall, having no safe place of his own for so large an amount of coin, deposited it for security with the consul of the Netherlands, taking his receipt for it at the time of the deposit. The transaction on the part of the bank was in no respect a secret one. The resolution which determined upon it was unanimously adopted at a full meeting of the Board of Directors, and inserted in their journal of proceedings, and all the corresponding and necessary entries were made in their appropriate places in the books of the bank.

The same bank, having occasion for a further

credit in Europe on which to draw exchange, purchased of Messrs. Dupasseur and Co., a French house in the city, bills on Paris for about \$750,000, paying for them as agreed in coin. The amount was delivered to the house by the bank and deposited by them, they being French subjects, with the French consul, until it could be shipped to Paris, to cover the bills. At the same time the bills were handed to the bank, which transmitted them as soon as it could to its correspondent in Europe, to be at the proper period presented for acceptance and payment. It was a part of the understanding that the Paris bankers were not to accept until they were advised of the shipment of the coin. Before that could be effected, Maj.-Gen. Butler, hearing that the coin was in possession of the consul, and conjecturing that the transaction was illegal, requested him to retain it.

From these facts Mr. Johnson concluded that the transaction was a purely mercantile one, in perfect good faith, and that the United States could have no interest in the coin except upon the ground of forfeiture, for which there had never been any pretence. "If it be alleged," he observed, "as matter of suspicion (the proof is all the other way) that the purpose of the bank was to place so much of its funds beyond the control of the United States, that, if true, would be no cause of forfeiture, there being no law, State or Congressional, to prohibit it. If it be alleged that the purpose was to place the fund in Europe for the advantage of the rebels, the answer is, there is not only no proof of the fact, but the proof actually before me wholly contradicts it." In a published card in reply to statements in the newspaper press as to the ultimate destination of the money, he denied emphatically that it had been sent in whole or in part to Havana to purchase arms and clothing for the Confederate Government, or that it had been employed for any purpose connected with secession. His report was approved by the President, and in the latter part of August instructions were sent to Gen. Butler to relinquish all claims on behalf of the United States upon the funds in question.

On two other occasions Gen. Butler was brought into conflict with the consuls under circumstances which produced an unusually acrimonious correspondence. In a communication dated June 11, the British, French, and Greek consuls complained that certain sugars bought by Covas & Co. and Ralli, Benachi & Co., foreign houses in New Orleans, on foreign account, in the usual manner in which such business is carried on, were prohibited by the commander-in-chief to be removed. "But," they added, "as the undersigned are disposed to waive all past proceedings, they beg that the order not permitting the removal of the produce in question be rescinded and the sugars left at the disposal of the purchasers."

In reply Gen. Butler stated that he had information that Covas had sold sterling exchange for Confederate treasury notes, with which he

had purchased the sugars, for which reason he had directed the latter to be detained until the matter could be investigated. In allusion to the offer by the consuls "to waive all past proceedings," he used the following strong language:

What "proceedings" have you, or either of you, to "waive" if you do feel disposed so to do? What right have you in the matter? What authority is vested in you by the laws of nations or of this country, which gives you the power to use such language to the representative of the United States in a *quasi* official communication? Commercial agents merely of a subordinate class, consuls have no power to waive or condone any proceeding, past or present, of the Government under whose protection they are permitted to reside so long as they behave well. If I have committed any wrong to Mr. Covas, you have no power to "waive" or pardon the penalty or prevent his having redress. If he has committed any wrong to the United States, you have still less power to shield him from punishment. I take leave to suggest, as a possible explanation of this sentence, that you have been so long dealing with a rebel Confederation, which has been supplicating you to make such representations to the Governments whose subjects you are, as would induce your sovereigns to aid it in its traitorous designs, that you have become rusty in the language proper to be used in representing the claims of your fellow citizens to the consideration of a great and powerful Government, entitled to equal respect with your own. In order to prevent all misconception, and that, for the future, you, gentlemen, may know exactly the position upon which I act in regard to foreigners resident here, permit me to explain to you that I think a foreigner resident here has not one right more than an American citizen, but at least one right less, that is, that of meddling or interfering, by discussion, vote, or otherwise, with the affairs of government.

A few days subsequent to this correspondence the consuls of Spain, France, and several other countries presented an elaborate protest against those clauses in General Order No. 41, which prescribed a form of oath to be taken by all foreigners resident 5 years in the city, and who had not received a protection from their Government within 60 days previous to the publication of the order. The reply of Gen. Butler was similar in style and tone to that above given. "Were it not," he said, "that some of the expressions of the document show that it was composed by some one born in the English tongue, I should have supposed that many of the misconceptions of the purport of the order, which appear in the protest, arose from an imperfect acquaintance with the peculiarities of our language. As it is, I am obliged to believe that the faithlessness of the Englishman who translated the order to you, and wrote the protest, will account for the misapprehensions under which you labor in regard to its terms." He then showed that the order was intended to reach a large class of foreign born residents who by their acts had lost their nationalities; that the limitation of the time in which protection must be given was necessary to secure good faith, some of the consuls having gone into, and being then actually in rebel service; that foreigners declining to take the oath were not prohibited, as was alleged, from leaving the city on application to the proper offi-

cers, and that those taking it did not necessarily become naturalized. He requested, in conclusion, that "no more argumentative protests" against his orders should be sent to him by the consuls as a body, that being no part of their duties or rights, but that they should make application for redress in the customary manner.

Business meanwhile began to assume some activity; a degree of order previously unknown in the city was maintained, and, owing to the stringent quarantine regulations enforced by the commander-in-chief, the sanitary condition of all classes of the inhabitants was unusually good. On June 14, the first of a series of Union meetings was held, at which several of the old residents were present and made speeches, and the papers of the 17th announced a gratifying increase of Union sentiment among the population at large.

During the summer no material change in the condition of things was experienced, the attention of Gen. Butler being directed toward the gradual weakening of the latent disunion power which still existed to a considerable extent among the wealthy classes. By an order issued July 25th, all negroes leaving New Orleans by direction of their masters, and who joined the national forces, were declared free; and early in the succeeding month a tax of \$812,716 for the relief of the poor was levied on disloyal corporations and firms, being 25 per cent. of their contributions in aid of the Southern Confederacy. Confiscations of the property of prominent secessionists, as Gen. Twiggs and John Slidell, were also ordered. Subsequent to August 11, all the inhabitants of New Orleans were disarmed by order of the military commandant of the city, a proceeding which elicited a remonstrance from the French consul in behalf of French subjects. In reply, Gen. Butler stated that he "could see no just cause for complaint against the order," and promised the protection of the United States troops against any attempts at violence upon disarmed persons, no matter by whom attempted. To the Spanish consul, who protested against the stringency of the quarantine laws, he replied that his object in enforcing these laws in their strictness was "to save the inhabitants of New Orleans, as well Spanish as others, from the epidemic of yellow fever." In the latter part of August, the initiatory step in the formation of a negro soldiery was taken by reorganizing the "Native Guards," a colored corps of the Louisiana State militia, raised under the certificate issued by the former governor of the State, and placing them in the service of the United States. Other organizations of a similar kind followed, and by the close of the year this branch of the service was established on a permanent footing.

On Sept. 24, Gen. Lewis G. Arnold assumed command of all the national troops at New Orleans and Algiers, and on the same day Gen. Butler created a panic among the secession sympathizers, by ordering all Americans, male

and female, in his department, to renew their allegiance to the United States Government, under pain of fine and imprisonment at hard labor, and at the same time to submit a return of the amount of their real and personal property. The native population consequently flocked *en masse* to register their allegiance, and within a comparatively short time upward of 60,000 persons had complied with the order. Soon afterward an order was issued prohibiting all persons in New Orleans holding moneys or other property in trust for persons in or sympathizing with the Confederate service; or from paying over the same without an order from the military headquarters, under penalty of having to refund a similar amount to the United States; and on Oct. 22 the relief commission, whose labors had been regularly prosecuted since the previous May, was directed to supply no family where there was an able-bodied male member over 18 and under 45 years of age, who was either not employed, or had not enlisted in the United States army.

The month of November was distinguished by a further series of orders. The most important of these was one, framed in accordance with the provisions of the confiscation act of July, 1862, declaring sequestered all the property in the district called La Fourche, on the west side of the Mississippi, and all in that part of the State lying east of the Mississippi, except the parishes of Orleans, St. Bernard, and Plaquemines. Within these portions of the State sales or transfers of property were prohibited, and a commission was appointed to take possession of the districts in question, under whose direction the sugar plantations were worked in the absence of their owners, and the property of disloyal persons inventoried and sold for the benefit of the Government. From these sales, which continued until the middle of December, considerable sums were realized. Another order suppressed distilleries and other manufactories of intoxicating liquors; another announced that any officer, found drinking intoxicating liquors in any public drinking place, would be recommended to the President for dismissal from the service; and a third prohibited the arrest of any slave unless known to be owned by a Union citizen, or the imprisonment of a slave unless his expenses should be prepaid, the slave to be released when the money was exhausted. Gen. Butler also ordered a list of slaves confined in the police jail in the month of November to be published, and all whose jail fees were not paid within ten days to be discharged, adding: "This is the course taken in all countries with debtors confined by creditors, and slaves have not such commercial value in New Orleans as to justify their being held and fed by the city, relying upon any supposed lien upon the slave."

A prominent feature in the history of this month was a Union meeting, held on the 15th, which was terminated by a grand torchlight procession through the principal streets. On the same day the "National Advocate" news-

paper, established a few months previous, by Jacob Barker, and suppressed by order of Gen. Butler, for an improper publication, was allowed to be resumed, the editor having made a public apology. On December 8, in compliance with an order from Gen. Shepley, the military governor of Louisiana, an election for members of Congress was held, at which Benjamin F. Flanders and Michael Hahn were chosen to represent the first and second districts of the State, the elective franchise being accorded to all citizens who had taken the oath of allegiance.

The next event of importance was the arrival, on the evening of December 14, of Gen. Banks, who had been appointed to supersede Gen. Butler in command of the Department of the Gulf. The news excited surprise among all classes, and not a few of those opposed to the restoration of the national supremacy were sorry to part with an officer who, if obnoxious from his zeal in the discharge of his duties, had brought unexampled order and security to the city. A meeting of the two generals took place on the 15th, at which Gen. Butler tendered a cordial welcome to his successor, assuring him that the troops would render a cheerful obedience to his orders, and, on the 16th, General Banks issued a general order assuming command of the Department of the Gulf and of the State of Texas. Another order required all military and civil officers in the department to report to him, and a third suspended all public sales of property on account of the United States until further orders. On the 15th, Gen. Butler took leave of the troops lately under his command, alluding in glowing terms to their success in the field, to the restoration of order and quiet to New Orleans, to the feeding of starving wives and children of enemies, and stating that the expedition had cost the Government less by four fifths than any other. He said that the speaking of the word "farewell" was the only sorrowful thought he had, and commended them to their new commander as one worthy of their esteem. The following address to the people of New Orleans was issued on the succeeding day:

*Citizens of New Orleans:* It may not be inappropriate, as it is not inopportune in occasion, that there should be addressed to you a few words at parting, by one whose name is to be hereafter indissolubly connected with your city. I shall speak in no bitterness, because I am not conscious of a single personal animosity. Commanding the Army of the Gulf, I found you captured, but not surrendered; conquered, but not orderly; relieved from the presence of an army, but incapable of taking care of yourselves. So far from it, you had called upon a foreign legion to protect you from yourselves. I restored order, punished crime, opened commerce, brought provisions to your starving people, reformed your currency, and gave you quiet protection, such as you had not enjoyed for many years. While doing this, my soldiers were subjected to obloquy, reproach, and insult. And now, speaking to you, who know the truth, I here declare that whoever has quietly remained about his business, affording neither aid nor comfort to the enemies of the United States, has never been interfered with by the soldiers

of the United States. The men who had assumed to govern you and to defend your city in arms having fled, some of your women flouted at the presence of those who came to protect them. By a simple order (No. 26) I called upon every soldier of this army to treat the women of New Orleans as a gentleman should deal with the sex, with such effect that I now call upon the just-minded ladies of New Orleans to say whether they have ever enjoyed so complete protection and calm quiet for themselves and their families as since the advent of the United States troops. The enemies of my country, unrepentant and implacable, I have treated with merited severity. I hold that rebellion is treason, and that treason persisted in is death, and any punishment short of that due a traitor gives so much clear gain to him from the clemency of the Government. Upon this thesis have I administered the authority of the United States, because of which I am not unconscious of complaint. I do not feel that I have erred in too much harshness, for that harshness has ever been exhibited to disloyal enemies of my country, and not to loyal friends. To be sure, I might have regaled you with the amenities of British civilization, and yet been within the supposed rules of civilized warfare. You might have been smoked to death in caverns, as were the covenanters of Scotland, by the command of a general of the royal house of England; or roasted like the inhabitants of Algiers during the French campaign; your wives and daughters might have been given over to the ravisher, as were the unfortunate dames of Spain in the Peninsula war; or you might have been scalped and tomahawked as our mothers were at Wyoming, by savage allies of Great Britain, in our own Revolution; your property could have been turned over to indiscriminate "loot," like the palace of the Emperor of China; works of art which adorned your buildings might have been sent away, like the paintings of the Vatican; your sons might have been blown from the mouths of cannon, like the sepoy of Delhi; and yet all this would have been within the rules of civilized warfare as practised by the most polished and the most hypocritical nations of Europe. For such acts the records of the doings of some of the inhabitants of your city toward the friends of the Union, before my coming, were a sufficient provocative and justification. But I have not so conducted. On the contrary, the worst punishment inflicted, except for criminal acts punishable by every law, has been banishment, with labor, to a barren island, where I encamped my own soldiers before marching here. It is true, I have levied upon the wealthy rebels, and paid out nearly half a million of dollars to feed forty thousand of the starving poor of all nations assembled here, made so by this war. I saw that this rebellion was a war of the aristocrat against the middling men; of the rich against the poor; a war of the landowner against the laborer; that it was a struggle for the retention of power in the hands of the few against the many; and I found no conclusion to it save in the subjugation of the few and the disenfranchisement of the many. I therefore felt no hesitation in taking the substance of the wealthy, who had caused the war, to feed the innocent poor who had suffered by the war. And I shall now leave you with the proud consciousness that I carry with me the blessings of the humble and loyal under the roof of the cottage and in the cabin of the slave, and so am quite content to incur the sneers of the salon or the curses of the rich. I found you trembling at the terrors of servile insurrection. All danger of this I have prevented by so treating the slave that he had no cause to rebel. I found the dungeon, the chain, and the lash your only means of enforcing obedience in your servants. I leave them peaceful, laborious, controlled by the laws of kindness and justice. I have demonstrated that the pestilence can be kept from your borders. I have added a million of dollars to your wealth in the form of new land from the battue of the Mississippi. I have cleansed and improved your streets, canals, and public squares, and opened new avenues to unoccupied land. I have given you freedom of elections, greater

than you have ever enjoyed before. I have caused justice to be administered so impartially that your own advocates have unanimously complimented the judges of my appointment. You have seen, therefore, the benefit of the laws and justice of the Government against which you have rebelled. Why, then, will you not all return to your allegiance to that Government—not with lip service, but with the heart? I conjure you, if you desire to see renewed prosperity, giving business to your streets and wharves—if you hope to see your city become again the mart of the Western world, fed by its rivers for more than three thousand miles, draining the commerce of a country greater than the mind of man hath ever conceived—return to your allegiance. If you desire to leave to your children the inheritance you received of your fathers—a stable constitutional government—if you desire that they should in the future be a portion of the greatest empire the sun ever shone upon—return to your allegiance. There is but one thing that stands in the way. There is but one thing that this hour stands between you and the Government, and that is slavery. The institution, cursed of God, which has taken its last refuge here, in His providence will be rooted out as the tares from the wheat, although the wheat be torn up with it. I have given much thought to this subject. I came among you, by teachings, by habit of mind, by political position, by social affinity, inclined to sustain your domestic laws, if by possibility they might be with safety to the Union. Months of experience and of observation have forced the conviction that the existence of slavery is incompatible with the safety either of yourselves or of the Union. As the system has gradually grown to its present huge dimensions, it were best if it could be gradually removed; but it is better, far better, that it should be taken out at once than that it should longer vitiate the social, political, and family relations of your country. I am speaking with no philanthropic views as regards the slave, but simply of the effect of slavery on the master. See for yourselves. Look around you and say whether this saddening, deadening influence has not all but destroyed the very framework of your society. I am speaking the farewell words of one who has shown his devotion to his country at the peril of his life and fortune, who in these words can have neither hope nor interest, save the good of those whom he addresses; and let me here repeat, with all the solemnity of an appeal to Heaven to bear me witness, that such are the views forced upon me by experience. Come, then, to the unconditional support of the Government. Take into your own hands your own institutions; remodel them according to the laws of nations and of God, and thus attain that great prosperity assured to you by geographical position, only a portion of which was heretofore yours.

BENJAMIN F. BUTLER.

To the address of the retiring commander-in-chief succeeded the following proclamation of Gen. Banks:

HEADQUARTERS, DEPARTMENT OF THE GULF, }  
NEW ORLEANS, Dec. 16, 1862. }

In obedience to orders from the President of the United States, I assume command of the Department of the Gulf, to which is added, by his special order, the State of Texas.

The duty with which I am charged requires me to assist in the restoration of the Government of the United States. It is my desire to secure to the people of every class all the privileges of possession and enjoyment consistent with public safety, or which it is possible for a beneficent and just government to confer.

In execution of the high trust with which I am charged, I rely upon the coöperation and counsel of all loyal and well-disposed people, and upon the manifest interest of those dependent upon the pursuits of peace, as well as upon the support of the naval and land forces.

My instructions require me to treat as enemies those

who are enemies, but I shall gladly treat as friends those who are friends. No restrictions will be placed upon the freedom of individuals which is not imperatively demanded by considerations of public safety; but, while their claims will be liberally considered, it is due also to them to state that all the rights of the Government will be unflinchingly maintained. Respectful consideration and prompt reparation will be accorded to all persons who are wronged in body or estate by those under my command.

The Government does not profit by the prolongation of the civil contest, or private or public sufferings which attend it. Its fruits are not equally distributed. In disloyal States desolation has its empire, both on sea and on land. In the North the war is an abiding sorrow, but not yet a calamity. Its cities and towns are increasing in population, wealth, and power. Refugees from the South alone compensate in great part for the terrible decimations of battle.

The people of this department who are disposed to stake their fortunes and lives upon resistance to the Government, may wisely reflect upon the immutable conditions which surround them. The valley of the Mississippi is the chosen seat of population, product, and power on this continent. In a few years twenty-five millions of people, unsurpassed in material resources, and capacity for war, will swarm upon its fertile rivers. Those who assume to set conditions upon their exodus to the Gulf count upon power not given to man. The country washed by the waters of the Ohio, Missouri, and Mississippi can never be permanently severed. If one generation basely barter away its rights, immortal honors will rest upon another that reclaims them.

Let it never be said either that the East and the West may be separated. Thirty days' distance from the markets of Europe may satisfy the wants of Louisiana and Arkansas, but it will not answer the demands of Illinois and Ohio. The valley of the Mississippi will have its deltas upon the Atlantic. The physical force of the West will debouch upon its shores with power as resistless as the torrents of its giant river.

This country cannot be permanently divided. Ceaseless wars may drain its blood and treasure; domestic tyrants or foreign foes may grasp the sceptre of its power; but its destiny will remain unchanged. It will still be united. God has ordained it. What avails, then, the destruction of the best Government ever devised by man, and the self-adjusting, self-correcting Constitution of the United States?

People of the Southwest, why not accept the conditions imposed by the imperious necessities of geographical configuration and commercial supremacy, and reestablish your ancient prosperity and renown? Why not become founders of States, which, as entrepôts and depots of your own central and upper valleys, may stand in affluence of their resources without a superior, and in the privileges of the people without a peer among the nations of the earth?

N. P. BANKS,  
Major-General Commanding.

The commencement of Gen. Banks's administration was marked by a leniency which seemed to indicate that the severity Gen. Butler had thought it necessary to exercise was either distasteful to the new commander or contrary to the policy of the Government, and among other conciliatory measures adopted was one releasing a number of political prisoners. But a portion of the people abused his clemency by various demonstrations, which brought out the following significant warning:

HEADQUARTERS, DEPARTMENT OF THE GULF, }  
NEW ORLEANS, Dec. 21, 1862. }

Information has been received at these headquarters that publications, injurious to the character of soldiers of the United States, are circulated in the streets, and

that anonymous and threatening letters are sent to officers connected with the public service. Such practices are indecent, offensive, and criminal, and must be suppressed. The troops of this department are instructed to observe a respectful deportment to all persons, and the same deference will be exacted from all persons in their favor. Any attempt on the part of any person whatever by offensive personal conduct to excite passion, or which tends to personal altercation or controversy and the disturbance of the public peace, will be punished with the sharpest severity known to the military laws. The Commanding General requests that any violation of this order may be reported to these headquarters or to the Provost Marshal General.

By command of Maj.-Gen. BANKS.

That this did not immediately produce the effect intended was shown by the riotous conduct of several citizens, who, on Christmas Day, cheered in the public streets for President Davis, and used threatening language toward the military authorities. Prompt measures were taken to prevent the repetition of such acts, and the close of the year found the city excited and exhilarated at having escaped from the iron rule of Gen. Butler, and apparently confident of its ability to disconcert a commander in every respect competent to rule with harshness, should his moderation be despised. The population of New Orleans in 1860 was 168,675.

NEW YORK, the most populous State in the Union, increased in population 783,331 during the ten years preceding 1860. The largest percentage of this increase has been in the cities of the State, which was 58.39 per cent. The additional details of the census of 1860, which were made up in 1862, relative to New York, will be found under UNITED STATES, to which the reader is referred.

The political aspect of the State of New York underwent a remarkable change during the year 1862. This was not apparent at the spring elections of the towns and counties, when the local officers were chosen of the same political character as at the presidential election in 1860. As the year progressed, however, it became apparent that the popular opinion was undergoing a change, and this became more manifest when the general war policy of the Federal Administration assumed a new phase. The Administration party went into the canvass with the most radical men in nomination. Gen. James S. Wadsworth, as candidate for governor, represented the most extreme views of the republicans. Horatio Seymour, once before governor, was again placed in nomination as the democratic candidate, together with members for the 38th Congress. The election, after a very exciting canvass, resulted in a complete change of parties in the State. The Legislature had passed the bill districting the State for the choice of members of Congress under the census of 1860. This State had forty representatives under the census of 1830, thirty-four under that of 1840, thirty-three under that of 1850, and now thirty-one under that of 1860. She will of course have but thirty-three electors of President in the next three presidential elections.

New York has thus lost three members in 30 years. The rule was established, in 1850, of limiting the number of representatives in Congress to 233.

The great mass of the citizens of the State were divided into only two political parties, the democratic and the republican. A small number of voters however associated themselves in a third party, which, in the election, cooperated with the democratic party. Their views were comprised in the phrase "The Constitution, the Union, and the enforcement of the laws." They had been the most active members of what had been formerly called the "American party." These voters held a convention at Troy, and nominated Horatio Seymour for governor, and adjourned.

A few days afterward the convention representing the democratic voters assembled in Albany, and nominated the following candidates for State officers:

*For Governor*—Horatio Seymour.  
*For Lieutenant Governor*—David R. Floyd Jones.  
*For Canal Commissioner*—W. J. Skinner.  
*For Inspector of State Prisons*—Gaylord J. Clark.  
*For Clerk of Court of Appeals*—Frederick A. Tallmadge.

The views of this convention on national affairs were unanimously expressed in the following resolutions:

*Resolved*, That the democracy of New York, waiving the expression of their views upon questions not rendered imperative by the imperilled condition of their country, hereby declare—

*First*. That they will continue to render the Government their sincere and united support in the use of all legitimate means to suppress the rebellion and restore the Union as it was and maintain the Constitution as it is—believing that that sacred instrument, founded in wisdom by our fathers, clothes the constituted authorities with full power to accomplish such purpose.

*Second*. That by the following resolution, unanimously passed by Congress in July, 1861, the Government was pledged to the policy inculcated therein, and which cannot be departed from without violation of public faith, viz:

*Resolved*, That the present deplorable civil war has been forced upon the country by the disunionists of the Southern States, now in arms against the Constitutional Government, and in arms around the capital; that in this national emergency Congress, banishing all feelings of mere passion or resentment, will recollect only its duty to the whole country; that this war is not waged, on their part, in any spirit of oppression, or for any purpose of conquest or subjugation, or purpose of overthrowing or interfering with the rights or established institutions of those States, but to defend and maintain the supremacy of the Constitution and to preserve the Union, with all the dignity, equality, and rights of the several States unimpaired; and that as soon as these objects are accomplished the war ought to cease.

*Third*. That we, having confidence in the loyalty of citizens of New York, reiterate the sentiments heretofore expressed by the democratic party—that the illegal and unconstitutional arrests and imprisonment of citizens of this State are without the justification of necessity, and we denounce such arrests as a usurpation and a crime, and that the freedom of the press, equally protected by the Constitution, ought to be maintained.

*Fourth*. That we are willing to act in the coming election with any class of loyal citizens who agree with us in the principles herein expressed; that we hereby

invite the cooperation of all citizens in giving the most emphatic expression to these principles by supporting the ticket nominated by the convention.

A convention representing the views of the republican party assembled at Syracuse on the 24th of September, and nominated the following candidates for State officers:

*For Governor*—James S. Wadsworth.  
*For Lieutenant Governor*—Lyman Tremain.  
*For Canal Commissioner*—Oliver Ladue.  
*For Prison Inspector*—Andreas Willmann.  
*For Clerk of Appeals*—Charles Hughes.

The views of the convention on national affairs were expressed by the following resolutions:

1. *Resolved*, That in the midst of the gigantic and perilous civil war which the slaveholders of the South have forced upon the nation all minor party distinctions are to be forgotten, and all minor political questions to be suspended until the rebellion is entirely crushed.

2. *Resolved*, That we commend the candidates nominated by this convention to the cordial, undivided support of all friends of the Union as men of incorruptible integrity, of the highest capacity, and approved and devoted patriotism.

3. *Resolved*, That we urge upon the National Government the prosecution of the war with the utmost vigor and energy in the field, and with the utmost unity and decision in the Cabinet, and by all the means that the God of Battles has placed in its power, bearing ever in mind that a revolt so wanton, so malignant, so pernicious is only to be overcome by the strong arm of force.

4. *Resolved*, That we hail with the profoundest satisfaction the recent proclamation of the President of the United States, enforcing the laws of the land against the property of traitors in arms, and declaring his intention to emancipate the slaves of all rebels who do not return to their allegiance by the 1st of January, 1863.

5. *Resolved*, That our heartfelt gratitude is due to the gallant officers and men of our loyal armies and fleets, wherever they may be; that we offer to them our highest admiration for their heroic courage, patient endurance, and indomitable zeal, and we promise them our earnest and unceasing efforts to relieve their distresses, strengthen their arms, fortify their hearts, and provide for the future well-being of themselves and their families.

6. *Resolved*, That the promptitude and enthusiasm with which the people of the State of Pennsylvania and Ohio sent one hundred thousand armed men each to repel the rebel invader from the soil of freedom entitle them to the thanks of the loyal men of every State, while it shows the spirit in which the loyal men of every State are prepared to meet the foe, come when he may.

7. *Resolved*, That measures should be taken immediately by the proper authorities of the State for enrolling, arming, and disciplining its militia.

8. *Resolved*, That our young and noble free republic should be proud of the distinction that her only enemies are the savages of the West, and the rebels of the South, their sympathizers and supporters at the North, and the despots of Europe.

In addition to the State officers thirty-one members of Congress were to be chosen, and members of the State Legislature, being one half the Senate, and all the members of the Assembly.

The election was held on the first Tuesday in November, being the 4th, and the results were as follows:

OFFICE.	Elected.	Votes.	Defeated.	Votes.	Total votes.
Governor.....	*Horatio Seymour.....	306,649	James S. Wadsworth.....	295,897	603,088
Lieutenant Governor.....	*D. R. F. Jones.....	306,705	L. Tremain.....	296,593	603,405
Canal Commissioner.....	*W. J. Skinner.....	307,316	Oliver Ladue.....	296,101	603,656
Prison Inspector.....	*Gaylord J. Clark.....	306,422	Andreas Willmann.....	296,945	603,655
Clerk Court of Appeals.....	*F. A. Tallmadge.....	305,467	Charles Hughes.....	296,793	602,505
<b>Thirty-eighth Congress—</b>					
1st District.....	*H. G. Stebbins.....	9,908	R. C. McCormick.....	7,759	17,672
2d ".....	*M. Kalbfleisch.....	10,588	W. Wall.....	5,381	16,056
3d ".....	*M. F. Odell.....	8,915	J. Humphrey.....	7,506	16,489
4th ".....	*B. Wood.....	7,828	H. Walbridge.....	4,585	12,400
5th ".....	*F. Wood.....	8,176	John Duffy.....	3,488	11,720
6th ".....	*E. Ward.....	6,942	F. A. Conklin.....	4,839	12,797
7th ".....	*J. W. Chanler.....	9,326	H. A. Burr.....	2,987	12,314
8th ".....	*James Brooks.....	9,625	E. C. Cowdin.....	5,570	15,321
9th ".....	*A. Herrick.....	7,828	J. M. Murphy.....	4,085	11,422
10th ".....	*W. Radford.....	8,578	E. Haight.....	7,921	19,389
11th ".....	*C. H. Winfield.....	9,326	S. W. Fullerton.....	7,572	16,912
12th ".....	*H. A. Nelson.....	10,275	C. L. Beele.....	8,965	19,265
13th ".....	*J. B. Steele.....	10,263	Thos. Cornell.....	8,422	18,692
14th ".....	*E. Corning.....	15,715	H. Smith.....	10,665	26,385
15th ".....	*J. A. Griswold.....	12,226	E. Dodd.....	10,939	23,175
16th ".....	O. Kellogg.....	7,654	B. P. Burham.....	6,987	14,643
17th ".....	C. S. Hubbard.....	12,015	D. C. Judson.....	5,567	17,891
18th ".....	J. M. Marvin.....	13,096	J. Blood.....	12,582	25,691
19th ".....	S. F. Miller.....	14,918	R. Parke.....	18,528	28,458
20th ".....	A. W. Clark.....	14,826	L. Carryl.....	11,031	25,575
21st ".....	*F. Kernan.....	9,943	R. Conkling.....	9,845	19,790
22d ".....	D. C. Littlejohn.....	12,667	W. Litus.....	8,453	21,150
23d ".....	T. T. Davis.....	13,032	G. M. Strong.....	9,257	22,314
24th ".....	T. M. Pomeroy.....	13,834	S. G. Hadley.....	11,196	25,043
25th ".....	D. Morris.....	11,615	S. Lord.....	8,157	19,778
26th ".....	G. W. Hotchkiss.....	13,889	C. G. Day.....	9,731	23,677
27th ".....	R. B. Van Valkenburgh.....	14,887	S. G. Hathaway.....	10,774	25,667
28th ".....	Freeman Clark.....	11,193	S. E. Church.....	9,883	21,031
29th ".....	A. Frank.....	10,470	W. Hunt.....	9,627	20,114
30th ".....	*J. Lawson.....	12,400	E. G. Spaulding.....	8,955	21,404
31st ".....	R. B. Fenton.....	11,950	S. D. Caldwell.....	6,982	18,940

\* On the democratic ticket.

The first fourteen of the Congressional districts gave majorities for Seymour, and the other 17 districts gave majorities for Wadsworth. The vote in these districts, as compared with the vote of 1860, was as follows:

	1860.		1862.	
	Repub.	Dem.	Wads.	Seym.
Fourteen districts.....	110,249	149,796	86,450	141,041
Seventeen districts.....	252,897	163,714	209,483	163,603
Total.....	363,146	313,510	295,897	306,649

In the interior of the State there was an actual gain of 2,894 on the side of the democrats, while there was a decline of 40,665 in the number of votes cast. The votes for members of the Legislature divided that body as follows:

	Republican.	Democrat.
Senate.....	23	9
House.....	64	64

The revenue of the State of New York for the year 1862 was greatly improved, through the increased receipts from the canals, derived as well from enlarged tonnage as from higher tolls, which in gross reached the large sum of \$5,180,000, of which \$4,854,959.67 were net receipts, an excess of \$946,254 over the previous year. The whole receipts of the treasury were as follows:

Receipts from all sources October 1, 1861, to September 30, 1862.....	\$20,840,913 20
Payments same period.....	18,166,238 86
Excess receipts.....	\$2,675,684 34
Balance October 1, 1861.....	3,074,941 85
In treasury October, 1862.....	5,750,626 19

The operation of the canal department was as follows:

RECEIPTS.	EXPENSES.
On hand October 1, 1861.....	\$2,120,000 00
Canal tolls for fiscal year.....	1,429,859 36
Proceeds from taxes for fiscal year.....	1,758,621 83
Other sources.....	509,392 10
Total.....	\$5,808,811 79
Balance on hand September 30, 1862.....	4,589,908 88

The sum of the principal and interest of the debt paid during the year, \$3,549,857.36, was paid in specie, at considerably increased expense to the State, since none of its revenues were paid in coin, which was at a high premium. With the depreciation of the Federal paper, this charge is likely to prove onerous. The tolls and canal dues are payable in the bankable currency of the State, and the State deposits in banks are payable in the legal tender of the

Government. The State honor and credit were held to require the payment of its debts in the currency, specie, in which they were contracted. When the Federal Government, therefore, imposed upon the State a depreciated currency for its revenues, it subjected it to a tax of over \$1,000,000 to buy coin with which to pay interest. This was not the only mode, however, in which the Federal Government absorbed the means of the State. An act of

Congress exempts United States stocks from State taxation, and the New York banks held \$125,000,000 of the various Federal stocks. Thus that large sum was withdrawn from the operation of State taxes, diminishing the State revenue nearly \$600,000, in addition to the sums held by individuals. The commissioners of internal revenue also claimed that the stamps and other taxes were applicable to the transactions of the State treasury. The House of Representatives passed a bill to exempt State Governments from taxation. This was rejected in the Senate—thus intimating on the part of that body a purpose to absorb State revenues into the Federal treasury; since, the right to tax being admitted, there is no limit to the rate, which may comprise the whole.

The debt of the State, Oct. 1, 1862, was as follows:

Of canal debt.....	\$23,931,610 25
Of general fund debt.....	6,505,654 87
<b>Total State debt.....</b>	<b>\$30,437,264 03</b>

By abstaining from further borrowing, and by depositing the usual annual contributions to the credit of the sinking funds, the comptroller estimates that the above debt will be substantially extinguished within 12 years.

The canal debt at that time was held as follows:

On United States account.....	\$32,523,782 59
On foreign account.....	1,452,327 86
<b>Total canal debt.....</b>	<b>\$33,976,110 45</b>

The canal debt was nearly all held by the bank department, as security for bank circulation, as follows:

*Statement of New York State Canal Stock, held by Banking and Insurance Corporations in the State of New York.*

By whom held.	Amount.	Interest per annum.
Banks 5's .....	\$5,200,106 13	\$250,005 81
Do. 6's .....	11,094,654 00	665,679 86
Do. 7's .....	925,000 00	15,750 00
	<b>\$16,519,760 13</b>	<b>\$941,434 67</b>
Savings Banks 5's .....	\$445,667 00	\$22,283 35
Do. 6's .....	2,060,700 00	123,642 00
Do. 7's .....	104,000 00	7,280 00
Insurance Companies 5's.....	\$152,400 00	\$7,620 00
Do. 6's.....	230,000 00	13,800 00
Do. 7's.....	570,000 00	39,900 00
	<b>\$942,400 00</b>	<b>\$60,720 00</b>
	<b>\$20,072,529 13</b>	<b>\$1,155,360 02</b>

The State paying the interest on these stocks at a time when gold was at 80 per cent. prem. for the United States legal tender, raised the amount of interest to be paid to nearly \$1,500,000. The operation of the banking law framed by Congress was intended to cause a substitution of United States bonds for the New York stocks thus held as security for circulation. The tax is imposed upon banks organized under the new law as well as upon the old banks, but not to so great an extent.

The banks of the State of New York under-

went some change during 1862. Of the old banks 7 charters expired, as follows:

BANKS.	Capital.	Authoriz. circula'n.	Circula'n Sept. 1862.
Bank of Orange County, Goshen.....	\$105,660	\$178,000	\$280,300
Bank of Rome, Rome.....	100,000	150,000	.....
Bank of Salina, Syracuse.....	150,000	175,000	.....
Essex County Bank, Keeseville..	100,000	150,000	.....
Schenectady Bank.....	150,000	175,000	161,000
Steuben County Bank, Bath.....	150,000	175,000	92,000
Leather Manuf. Bank, N. Y. City	600,000	450,000	297,000

Of these, three—the Bank of Rome, Bank of Salina, and the Essex County Bank—ceased business, and are winding up their affairs. The four others, with six new associations, and six individual bankers, deposited securities and commenced business under the general law, raising the number of banks doing business in the State to 305. There are also 53 in process of liquidation at the close of the fiscal year.

There had been a substitution of United States stock for other securities during the year. The circulation in 1862 increased \$9,541,625, as follows:

	New York City Banks.	Other banks.	Total circulation.
September, 1861.....	\$6,540,119	\$20,475,629	\$28,015,748
September, 1862.....	2,710,016	27,847,857	87,557,873
<b>Increase.....</b>	<b>\$1,179,897</b>	<b>\$7,371,728</b>	<b>\$9,541,625</b>

This large increase was compelled to some extent by the withdrawal of the metals from circulation, causing an urgent demand for small notes, which the banks alone could supply. This demand was the more urgent as the United States issued none under \$5, and the larger the issues of those the more small notes were required to make change. Hence, notwithstanding the increased circulation, the redemptions were less, and also the number of notes returned upon the department.

The amount of Federal stocks held by the New York banks at the close of the year was as follows:

United States stocks.....	\$31,631,708
Treasury Notes, 7.30's.....	25,383,505
Indebtedness certificates.....	14,941,879
Certificates bearing interest.....	37,047,370
Certificates payable in gold.....	6,774,612
Demand and Legal Tender Notes.....	20,189,098
<b>Total of Banks.....</b>	<b>\$135,968,044</b>
Savings Banks funded.....	10,892,102
"    "    unfunded.....	7,624,426
<b>Total.....</b>	<b>\$153,956,574</b>

The entire funded debt of the Government being at the same time \$500,978,142. The New York banks held about 80 per cent. of it, or an amount double the sum of their aggregate capital, and were not in a position to make further advances to the Government.

The number of railroads in the State of New York, is 82; of these 18 made their annual reports for 1862 to the State engineer at Albany. The aggregate of the reports shows the following results:

Amount of capital stock authorized.....	\$102,054,400
Amount of capital stock paid in.....	87,404,685
Amount of funded debt.....	69,067,968



Amount of floating debt .....	\$1,670,379
Amount of funded and floating debt .....	70,788,354
Total cost of construction and equipment of roads .....	145,198,968
Total cost excluding city roads .....	186,659,797
Length of roads in miles .....	8,819
"    "    "    laid .....	2,800
"    "    "    in operation, &c., ex-	
cluding city roads .....	2,700
Miles run by passenger trains .....	10,850,907
"    "    "    city .....	6,448,777
<b>Total .....</b>	<b>17,299,634</b>
Number of passengers of all classes carried in cars .....	59,690,601
Same, excluding city cars .....	12,970,455
Number of miles travelled by passengers, city roads not included .....	844,890,889
Miles run by freight trains .....	9,596,696
Number of tons carried .....	6,506,193
Total earnings .....	\$29,507,180
Of city roads .....	2,844,061
Total payments, including dividends, amount to surplus funds, &c. ....	28,231,190
Of which city roads .....	2,481,007
Number of passengers killed .....	92
Of which on city roads .....	6
Number of passengers injured .....	45
Of which by city roads .....	21
Number of employes killed .....	51
Others than employes and passengers killed ..	80
"    "    "    injured ..	42
Total killed (city roads, 12) .....	158
"    injured (city roads, 81) .....	115
Average cost per mile of road and equipment, excluding city roads .....	\$50,896 04
Do. of single track .....	82,386 52

Of the 82 companies 26 are passenger roads employing horse power only. Seven of these, being Buffalo, Syracuse, Brooklyn, and Troy roads, are formed under the general law and are therefore not required to report to the State engineer. The business of the two Grand Trunk roads for the year was comparatively as follows:

	Erie Railroad.	Central Railroad.	Total.
Passengers .....	\$1,200,451	\$2,389,794	\$3,590,175
Freights .....	7,065,268	6,607,380	13,672,668
Miscellaneous .....	184,521	859,772	494,293
<b>Total 1862 .....</b>	<b>\$8,400,985</b>	<b>\$2,856,877</b>	<b>\$11,757,161</b>
"    1861 .....	6,214,181	7,809,042	13,523,223
<b>Increase .....</b>	<b>\$2,186,154</b>	<b>\$2,047,785</b>	<b>\$4,258,938</b>

The gain on the Erie in freight is very large, and in both roads the aggregate for the year is 25 per cent. in excess of the previous year, showing not only the effect of the war in sending produce East, but also the large share which New York gets of the business.

A report of a Senate committee on the manufacture of salt, states that, allowing nothing for the use of the salt works, which are private property, nor for the lands on which the salt works stand, the wells, pump-houses, machinery, aqueducts, &c., all of which belong to the State, the cost of producing salt did not exceed 11½ cents per bushel for fine or boiled, and 5 cents per bushel for coarse or solar.

The amount of salt inspected was 5,315,694 bushels of fine, and 1,884,697 bushels of coarse, making 7,200,391 bushels, producing, at 19 cents per bushel, \$1,368,074.29, the cost of which was, for 5,315,694 bushels fine at 11½ cents, \$606,804.81; for 1,884,697 bushels coarse at 5 cents, \$94,234.70. Total, \$700,539.51. Showing that it sold for \$607,534.76 more

than it cost to produce it, leaving out of the estimate all compensation for the use of the property, public or private, which contributed to its production.

The State of New York continued its gigantic exertions in support of the Federal Government and appropriated men and money with a lavish hand. It sent 120 regiments into the field in 1862, when the President made two successive calls, one for 800,000 men for the war, and the other for 800,000 men for nine months. New York offered and paid a bounty of \$50 per head to each volunteer, and the disbursements for 73,000 men amounted to \$3,650,000, carrying the State war expenditure to nearly \$10,000,000, making with town and county subscriptions fully \$20,000,000, paid by the people of the State of New York for bounties and for the support of the families of the troops. The entire number of regiments sent to the field was as follows:

28 infantry regiments, 8 months .....	15,838
88 "    "    "    2 years .....	30,181
128 "    "    "    8 years .....	112,411
Recruits for old regiments .....	29,690 - 188,079
11 cavalry regiments, 1 battalion .....	9,642
Artillery: 5 regiments, 6 battalions, 18 batteries ..	9,679
Engineers: 1 regiment .....	863
Ricketts' battalion .....	168
<b>Total .....</b>	<b>208,409</b>
Recruits in the State .....	10,650
<b>Total .....</b>	<b>219,059</b>

The recruits made for the regular army and for the regiments of other States may raise these figures to 225,000 men. Of the regiments raised, about 70 had their headquarters in New York City.

The Legislature passed a militia law, to enrol the citizens of the State, under State officers in accordance with the Federal Constitution. So far as it relates to the enrolment of persons subject to military duty, it differs but little from the old law. All persons in the army or navy or volunteer force of the United States, ministers of the Gospel, public officers and their official employes, Shakers and Quakers, professors, teachers and pupils in all institutions of education, firemen, and all persons who are by laws of the State or United States exempt from military duty, are exempted by this bill. So are all idiots, lunatics, paupers, habitual drunkards and persons convicted of infamous crimes. All other white male citizens shall be enrolled at least once in two years, by the commandant of the company district. Such enrolment shall be divided into two reserves. The first reserve comprises all white males between the ages of 18 and 30 years. The second reserve all between the ages of 30 and 45. This force, as enrolled, constitutes the reserve militia of the State.

There must be an annual inspection; fine for absence, \$1. The bill provides for the organization of a national guard. This includes the present uniformed militia of the State, and all volunteer companies that shall hereafter be organized in the several company districts of the

State. It consists of eight divisions, 32 brigades, and 128 regiments and battalions—the latter divisions to conform as nearly as possible to the Assembly districts; each company not less than 32, nor more than 100 men. The National Guard is to be uniformed at the expense of the State. All major-generals and the commissary-general are nominated by the governor, and confirmed by the Senate. Brigadier-generals and brigade inspectors are to be elected by the votes of the field officers of each brigade; field officers of each regiment by the votes of the commissioned line officers of the regiment; and captains and lieutenants by the votes of the company. No commissioned officer can be removed from office but by the Senate, on the recommendation of the governor, by a court-martial, or a retiring or examining board. The supervisors of each county in which a company of the National Guard shall be fully organized, are required to construct or rent a suitable armory for a drillroom, and place of deposit of the arms, uniforms, equipments and camp equipage of said company or companies, the expense of which is made a county charge. If the supervisors of the county neglect to do this, the commandant of the regiment is authorized to procure said armory, the annual rent of which shall not exceed \$250 for each company, which rent shall be a county charge and paid by the supervisors. There will be one annual brigade parade, and eleven drills in each year, and a monthly parade of each company. Second enlistment 7 years. The members are exempt from jury duty, highway taxes, &c. Camps of instruction are established in each division. Privates get \$1 each day of service. The power of the commander-in-chief is very ample; and although the selection of none of the officers except major-generals devolves upon him, yet the provisions of the bill give him almost absolute power as to their subsequent disposition. In May, under the call of the President for 50,000 troops, new regiments were organized and recruiting offices opened to fill up the old regi-

ments. The enrolment that took place consequent upon the order from Washington for a draft of men was completed in Sept., and the whole number between 18 and 45 was as follows:

PLACES.	Number enrolled.	Exempt.	Liab. to duty.
New York.....	207,186	41,286	165,900
Brooklyn.....	66,841	13,967	52,874
Rest of State.....	639,774	83,945	545,825
<b>Total.....</b>	<b>908,801</b>	<b>139,198</b>	<b>769,603</b>

The charter election for the city of New York was held Dec. 2, and the results were nearly the same as to the position of parties as at the November election. The number of votes polled was 64,280, or 12,551 less than in November. The results were as follows by wards for corporation counsel and comptroller:

WARDS.	Comptroller.		Corporation Counsel.	
	Hays, Republican.	Brennan, Democratic Union.	Bradford, Republican.	Devlin, Democratic Union.
1st Ward.....	828	1,216	195	906
2d ".....	189	201	150	217
3d ".....	218	288	170	261
4th ".....	837	1,390	161	1,525
5th ".....	748	1,297	458	1,467
6th ".....	188	3,013	124	2,993
7th ".....	985	1,590	759	2,087
8th ".....	1,210	1,741	836	1,993
9th ".....	2,881	1,702	1,892	3,048
10th ".....	1,066	1,208	760	1,415
11th ".....	1,388	2,688	905	2,972
12th ".....	1,126	1,587	778	2,224
13th ".....	840	1,497	661	1,585
14th ".....	404	1,798	261	1,874
15th ".....	1,548	890	1,228	1,068
16th ".....	1,997	1,832	1,655	2,111
17th ".....	1,919	3,048	1,490	3,582
18th ".....	1,869	2,077	1,824	2,159
19th ".....	1,119	1,647	898	2,020
20th ".....	2,016	3,082	1,698	3,377
21st ".....	2,080	1,905	1,688	2,142
22d ".....	1,596	2,458	1,385	2,687
<b>Total.....</b>	<b>25,860</b>	<b>38,685</b>	<b>18,366</b>	<b>42,668</b>

Brennan's majority, 13,505; Devlin's majority, 24,272. The whole board of councilmen were democratic Union.

The operations of the five city railroads for the fiscal year was as follows.

	Second Avenue.	Third Avenue.	Sixth Avenue.	Eighth Avenue.	Ninth Avenue.
Length of single track.....	16 miles.	16½ miles.	8½ miles.	16 miles.	18 miles.
Shares paid in.....	\$650,000	\$1,170,000	\$750,000	\$800,000	\$795,860
Funded debt.....	450,000	400,000	35,000	.....	22,000
Floating debt.....	42,500	.....	.....	25,000	.....
<b>Total capital.....</b>	<b>\$1,142,500</b>	<b>\$1,570,000</b>	<b>\$775,000</b>	<b>\$825,000</b>	<b>\$817,860</b>
Cost of railroad, &c.....	\$1,101,873	\$1,757,028	\$1,089,316	\$938,365	\$787,446
Passengers.....	4,711,119	11,482,892	6,955,647	7,899,696	1,789,968
Total receipts.....	\$242,065	\$566,736	\$386,915	\$369,955	\$89,498
Repairs, &c.....	\$3,688	\$21,591	\$63,062	\$13,108	\$4,060
Operating road.....	187,878	347,205	301,608	235,311	64,009
Interest.....	87,629	26,086	.....	.....	1,474
Dividend.....	.....	140,400	75,000	96,000	.....
<b>Total disbursements.....</b>	<b>\$229,195</b>	<b>\$555,283</b>	<b>\$344,666</b>	<b>\$344,419</b>	<b>\$71,548</b>

The length includes double track. The 2d avenue and 6th avenue began running in 1853. The 3d and 8th avenues in 1854, and the 9th in

1858. The number of passengers carried annually on each and all other routes was as follows:

YEARS.	Second Avenue.	Third Avenue.	Sixth Avenue.	Eighth Avenue.	Ninth Avenue.	Total.
1853.....	854,000	....	5,190,500	....	....	5,474,500
1854.....	2,500,000	....	5,195,581	....	....	7,695,581
1855.....	3,547,660	5,770,078	4,337,583	4,311,676	....	17,966,997
1856.....	3,367,871	7,181,881	4,757,108	6,097,399	....	21,353,659
1857.....	3,986,008	8,105,515	5,240,973	6,329,452	....	24,111,938
1858.....	4,504,645	7,945,462	5,612,357	6,763,208	....	24,730,667
1859.....	5,182,011	9,974,101	6,479,127	7,589,997	170,440	29,895,673
1860.....	5,195,609	12,109,417	7,898,908	7,775,040	1,934,841	34,464,893
1861.....	4,640,751	11,824,923	6,890,901	7,413,905	1,906,086	32,676,471
1862.....	4,711,119	11,483,392	6,955,647	7,399,696	1,739,968	32,389,817

These figures do not embrace the Harlem or 4th avenue railroad, nor include the omnibus travel. The number carried in each year increased annually until 1860, when it culminated. The war seems to have produced a diminution of the number carried. The population of the city increased during the ten years ending with 1860, nearly 300,000—but a large proportion of the passengers carried were strangers in the city. The number for 1860 exceeded by a few millions the whole population of the Union.

The colleges and academies of the State showed the usual degree of prosperity in the year 1862. There were 17 colleges in the State in operation, and three more in progress for females only. There are three others in course of organization. There are also 10 theological seminaries. Three are Roman Catholic. The number of medical schools is eleven—of law schools 5 are in operation, including the law school of Columbia College. Three colleges have first graduate scientific courses. There is also an agricultural college at Ovid, and the Polytechnic Institute at Troy.

The report of the regents of the university give the number of incorporated academies at 226; of them 220 made reports. The capital and investment were \$2,929,083, and debt \$23,681. The cash receipts were \$646,623. Teachers' salaries \$436,920—number of teachers, 1,043. The number of volumes in the libraries, 129,275. The number of students in attendance was 35,748, against 37,929 in the previous year. The existence of the war seemed to have an influence in diminishing the attendance.

NORTH CAROLINA, one of the original thirteen States of the Union, increased in population 23,583 during the ten years terminating in June, 1860. The further details furnished by the census of 1860 respecting North Carolina will be found under UNITED STATES, to which the reader is referred.

At the approach of Gen. Burnside's command upon the coast of North Carolina much confidence was felt on the part of the authorities that they would be able to make a successful resistance. A few days served to dispel these delusions, and change the aspect of their situation. The entire coast was exposed to the invasion of the Federal troops. This change quenched a spirit of dissatisfaction with the Confederate Government, which was beginning to prevail under grievances that the State had suffered. Efforts, however, were now made to prevent the advance of the Federal troops into

the interior, and to make as successful opposition to their movements as might be possible.

On the 13th of February the adjutant-general of the State, by order of the governor, issued a call for five regiments of volunteers for the war to make up the quota of the State in the Confederate army. A bounty of fifteen dollars was offered to each volunteer—to be paid by the State, and fifty dollars by the Confederate States.

When the subject of conscription was under consideration in the Confederate Congress, the people and the press of North Carolina generally took most decided grounds against it, as looking to a military despotism, as subverting the constitution and as destructive of personal liberty. It was said, "a panic prevails in the country, and those in authority have but to ask for power on the ground of military necessity, and the oldest and most sacred safeguards of freedom are yielded without a question." At the same time the Confederate Government sent an agent into the State to borrow, purchase, or, if necessary, impress all the arms in the hands of the citizens. This whole action was looked upon as, on the one hand, calling into the field, as hiring soldiers, all the fighting men between eighteen and thirty-five, and, on the other hand, disarming the remainder of the population. The governor, on the 15th of April, issued a proclamation to the citizens, stating that they would be protected in preserving from seizure their private arms as a means of self-defence, but requesting them to give information of all public arms.

By the action of the Legislature in encouraging private enterprise, an establishment was put in operation at Raleigh at the beginning of the year, which manufactured about two thousand pounds of powder daily. It bore a satisfactory trial in comparison with the Dupont powder.

The State convention, called into existence in 1861, for the purpose of passing the ordinance of secession, assembled at an adjourned session on the 21st of April. It was thought that such circumstances had occurred as to dispose many of its members to repeal that ordinance if it had been practicable.

The election for State officers in North Carolina takes place on the second Thursday in August. Some months before this election the person who should be the next governor of the State became a subject of active discussion. One party desired a man who was not a

proscriptive secessionist, and the other desired one who was radical and thorough on secession, and who would sustain the Confederate Government, even at the expense of State rights. Both parties sustained the war. The candidates nominated for the office were William Johnson, of Mecklenberg county, and Zebulon B. Vance, of Buncombe county. The grounds of opposition to Mr. Johnson were thus set forth:

Who is William Johnson of Mecklenberg, the democratic nominee for the high and responsible position of governor, is a question which is daily asked. Mr. Johnson is nominally a resident of Charlotte, Mecklenberg county, where he owns a considerable property. He is president of the Charlotte and South Carolina railroad, which runs from Charlotte to Columbia, the capital of South Carolina, where the business office of the road is located, and where Mr. Johnson resides, in which city he has made large investments and becomes thoroughly identified with the interests of South Carolina, and more especially is he identified with her political heresy of secession, in which he is most completely indoctrinated, and is what might be called a forward student in this new school of political science. He is a lawyer by profession, but has never risen above the sphere of a county practitioner in reputation. He has been a member of the Legislature, is a member of the sovereign convention of this State, and was among the first to vote in favor of secession.

Col. Vance, on the other hand, was opposed as "failing to enjoy the confidence of the friends of the Confederacy," and was thus spoken of:

Unfortunately, there appears to exist a belief (doubtless obtained from the course of the "Standard") among the troops that the election of Vance will bring peace, which will give him (Vance) all the votes of those who have been pressed into the ranks, which, including the votes from the opposition regiments, made up wholly as they are from the opposite party, may elect Vance.

The friends of Mr. Vance thus described their position: "We belong to the people's war party. Vance is the leader of it. It is for the war, and, at the same time, for liberty, conservatism, and reform at home."

The following is an appeal made by the friends of Mr. Johnson to the electors, urging them to vote against Col. Vance:

A governor and Legislature of North Carolina are to be elected Thursday, August 7. It will be the most important election held in the State. The duration of the war, and the faith of the South, hang upon the results. Whether Col. Vance or Mr. Johnson, as individuals, shall be elected, is a matter of small importance; but it is of great importance for the South to triumph in this war, and for North Carolina to continue true to the cause to the end of it, without manifesting the smallest signs of backing out and deserting the sisterhood of the Confederate States, after all their united sacrifices, when success is almost ready to crush the common foe, rendering independence and a nationality won by stout arms and brave hearts certain. Mr. Johnson, emphatically, is the Confederate or Southern candidate—the issue having been placed upon that ground by the press in the interest of Col. Vance, and likewise by political meetings held in his behalf and stump orators that have spouted around during the canvass. That is the issue which has been placed before the people of the State by the advocates of Col. Vance. And the question which the people will have to decide in this election, as thus presented, is, shall the State recede from the position which she

assumed to her Southern sisterhood when she withdrew from the United States, and again join the Yankee nation? The election of Col. Vance would indicate the popular will of the people of North Carolina to re-enter the old Union, and we desire that they will vote upon the question understandingly.

Then, of what avail will be the sacrifices which the people have made in prosecuting the war, of life and treasure? What will be thought of the State by the world? Can the people pay the State's share of the immense Yankee debt, amounting to more than all the property in the State would sell for? How could they wipe out the disgrace which such an event would entail upon the State? Have the people pondered the demoralizing effect which it would have upon our army. Consider well these things and vote accordingly.

The result of the election was the choice of Col. Vance as governor by a large majority. In forty-three of eighty-nine counties his majority exceeded 19,000. A majority of the members elected to the Legislature were of the same party with the governor.

On the 17th of November the Legislature assembled at Raleigh, and the governor delivered his Message. He urged a vigorous prosecution of the war, but complained of the bad faith of the Confederate Government in sending agents into the State to obtain clothing and supplies, after agreeing not to do so, if the State undertook to clothe her own troops. He condemned the conscription law; stated that the soldiers were suffering greatly for want of shoes and clothing. (*See ARMY, CONFEDERATE*). The debt of the State at the beginning of the year was \$2,098,861. Flour and corn commanded such prices as to be used only by wealthy persons.

The Legislature adopted the following resolutions on the 27th of November:

*Resolved*, That the Confederate States have the means and the will to sustain and perpetuate the Government they have established, and that to that end North Carolina is determined to contribute all her power and resources.

*Resolved*, That the separation between the Confederate States and the United States is final, and that the people of North Carolina will never consent to a reunion at any time or upon any terms.

*Resolved*, That we have full confidence in the ability and patriotism of his Excellency President Davis, and that his administration is entitled to the cordial support of all patriotic citizens.

*Resolved*, That we heartily approve of the policy for the conduct of the war set forth by his Excellency Gov. Vance to the General Assembly, and that he ought to be unanimously supported in the manly and patriotic stand he has taken for our independence.

The number of men obtained in the State by the conscription law was stated to exceed forty thousand, three fourths of whom were reported by the examining physicians as unfit for military duty. The destitution of the people in the interior of the State was very great, especially of salt, shoes, clothing, and corn. The exportation of the former from the State was forbidden by the governor. The removal of the conscripts did not leave men enough in some parts to gather a crop. In the seven days' battles before Richmond, North Carolina had in the field forty-two regiments of infantry; one of cavalry, and one company of artillery; the

number of wounded among them was 8,468, who were taken to the hospitals, without including several hundred who went home. For military affairs in North Carolina, (*see* ARMY OPERATIONS.)

On the 15th of May, Edward Stanley, formerly a distinguished citizen of North Carolina, arrived at New York from California, for the purpose of entering upon the office of temporary governor of North Carolina, which had been tendered to him by President Lincoln. The part of Carolina placed under his jurisdiction was that in which the Federal arms held control. The instructions of the Federal Government to Gov. Stanley were similar to those given to Gov. Andrew Johnson in Tennessee, and were as follows:

WAR DEPARTMENT, WASHINGTON, D. C., May 2, 1862.

*Hon. Edward Stanley, Military Governor of North Carolina:*

SIR: The commission you have received expresses on its face the nature and extent of the duties and power devolved on you by the appointment of military governor of North Carolina. Instructions have been given to Maj.-Gen. Barnside to aid you in the performance of your duties and the exercise of your authority. He has been instructed to detail an adequate military force for the special purpose of a governor's guard, and to act under your direction. It is obvious to you that the great purpose of your appointment is to reestablish the authority of the Federal Government in the State of North Carolina, and to provide the means of maintaining peace and security to the loyal inhabitants of that State until they shall be able to establish a civil government. Upon your wisdom and energetic action much will depend in accomplishing that result. It is not deemed necessary to give any specific instructions, but rather to confide in your sound discretion to adopt such measures as circumstances may demand. You may rely upon the perfect confidence and full support of this department in the performance of your duties.

With great respect, I am your obedient servant,  
EDWIN M. STANTON, Secretary of War.

On the 26th of May he arrived at Newbern, and entered upon his duties. On the 17th of June he made an address to the people at Washington, N. C. Permission had been given to the citizens to enter the Federal lines for the purpose of hearing this address, and they were present from seventeen counties. The speech was a review of the past, an examination of present affairs, and an urgent appeal to the citizens to resume their allegiance to the Federal Government. The result showed that so long as the Confederate Government retained its organization and power, the citizens could not be expected to turn against it; especially as the fortune of war might soon place them under its control again.

At all the military posts of the Federal Government in the State, the slaves from the interior who had run away collected. This was especially the case at Newbern, where five thousand had come in. When Gov. Stanley arrived there he found schools established for their instruction, but expressed the opinion that it was injudicious, as contrary to the laws of the State, and if upheld by him it must destroy his influence with the people. The schools were temporarily suspended. The course pursued by the governor was designed to restore the confidence and good will of the people, which had been lost by the belief that it was the purpose of the Federal Administration to destroy their institutions and subjugate the people. A conference was proposed by Gov. Stanley to Gov. Vance, for the purpose of restoring peace in the State. The latter refused to meet, but referred the former to the Confederate Government at Richmond. Apparently little has been gained for the Federal cause thus far by the military organization on the borders of the State.

## O

OBITUARIES, AMERICAN.—*Jan. 8.*—WATERMAN, THOMAS G., died in Binghamton, N. Y., in the 74th year of his age. He graduated at Yale College in 1806, studied law, and settled in Binghamton in 1812. From 1826 to 1832 he was in the State Legislature either as assemblyman or senator, and during that time assisted in revising the statutes of the State. He was judge of the court of common pleas in his own county, and a brigadier-general of the State militia by appointment of the governor. In 1828 he published a volume on the "Powers and Duties of Justices of the Peace."

*Jan. 10.*—COLT, COL. SAMUEL. (*See* COLT.)

*Jan. 14.*—INGERSOLL, CHARLES JARED. (*See* INGERSOLL.)

*Jan. 18.*—TYLER, JOHN. (*See* TYLER.)

*Jan. 25.*—DWIGHT, REV. HARRISON GRAY OTIS, D.D., a missionary of the American Board of Commissioners of Foreign Missions, killed by a railroad accident on the Northern Vermont

railroad. He was born in Conway, Mass., Nov. 22, 1803, graduated at Harvard University in 1825, and completed his theological course at Andover in 1828. In January, 1830, he sailed for the East, and after spending two years in exploring the field, settled as a missionary at Constantinople in 1832, and labored there nearly thirty years, preaching, superintending schools, and editing a religious paper. He had published during his long missionary career several works, one of them, "Christianity brought Home from the East," having met with a large sale.

*Jan. 27.*—PRET, EDWARD, professor in the New York Institution for the Deaf and Dumb, died in New York. He was born in Hartford, Conn., May 28, 1826, and graduated at the University of New York in 1847. The winter after his graduation he visited France, and upon his return studied law for one year in the office of James W. Gerard, Esq. In the fall of

1849 he was chosen professor in the New York Institution for the Deaf and Dumb; and soon after commenced his duties. Here he entered the Union Theological Seminary, and upon the completion of his course received the usual degrees, though he never preached. He published several text books for the use of deaf mutes.

*Jan. 29.*—ELIOT, HON. SAMUEL ATKINS, died in Cambridge, Mass. He was born in Boston, March 5, 1798, graduated at Harvard College in 1817; served in the Legislature and State Senate, and was mayor of Boston from 1837 to 1839. He was treasurer of Harvard College, and connected with the corporation from 1842 to 1853. He was also a representative in Congress from 1850-'51, and an officer of several literary and scientific associations.

*Feb. 1.*—BONGARS, GEN. THEODORE XAVIER THOMAS, Count de, died in New York, aged about 70 years. He was formerly an officer of high rank in the French army, and during the Mexican war commanded a regiment of New York volunteers. He belonged to a noble family in his native country, and was esteemed as a man of uncommon ability.

*Feb. 3.*—LARNED, WILLIAM AUGUSTUS, Professor of Rhetoric and English Literature in Yale College, died of apoplexy in New Haven, Conn. He was born in Thompson, Conn., June 28, 1806, graduated at Yale College in 1826, and spent the two following years in teaching at Salisbury, N. C. From 1828 to 1831 he was a tutor in Yale College, and at the close of this period devoted himself to the study of theology. In 1834 he was ordained pastor of the Congregational church in Millbury, Mass., but his health soon after failing, he resigned, and accepted proposals from the Rev. Dr. Beman and Rev. Mr. Kirk to engage with them in the instruction of a theological school in Troy, N. Y. In 1839 he was appointed professor of rhetoric and English literature in Yale College, as successor to Prof. C. A. Goodrich, and until his death discharged the duties of his office with faithfulness and success. He was a constant contributor to "The New Englander," his articles embracing a wide range of topics, and in 1854 and 1855 acted as its editor. In the later years of his life he prepared and printed, but did not publish, a valuable edition of the "Oration of Demosthenes on the Crown," with philological and rhetorical notes.

*Feb. 11.*—BELL, LUTHER V., M.D., died in camp near Budd's Ferry, Md. He was born in Francestown, N. H., in 1806, and was a son of the late Gov. Samuel Bell. He graduated with distinction from Bowdoin College before completing his 16th year, and while yet under 20, received his degree of M.D. from the Hanover Medical School, and commenced the practice of his profession in New York, but at the earnest solicitation of his friends returned to New Hampshire, and established himself in his native town, where he soon achieved professional

distinction. His writings on medical subjects, and especially on the treatment of the insane, attracted considerable attention, and his exertions in 1834 and 1835 ultimately led to the establishment of an asylum in his native State. In the mean time he was elected, without his knowledge, to the superintendency of the McLean Insane Asylum at Somerville, Mass., in which position he maintained a high reputation for nearly 20 years. He was a member of the Executive Council of Massachusetts, and candidate for governor in 1850. In 1845, the trustees of the Butler Hospital, Providence, R. I., procured his services to visit Europe and ascertain what improvements could be made in the plan of their new hospital. This mission was accomplished to their full satisfaction. At the time of his death he was medical director of Hooker's division of the army of the Potomac. Dr. Bell was the author of several able professional works, and some political essays. He also published a narrative of a careful and protracted investigation which he made into the alleged spiritual manifestations, which at the time excited much attention.

*Feb. 16.*—PENNINGTON, HON. WILLIAM, died at Newark, New Jersey, in the 65th year of his age. He was a native of the State; began life as a lawyer, and for some time filled the office of chancellor of the State. In 1837 he was appointed governor of the State, and served seven terms. In 1858 he represented the fifth New Jersey district in Congress, and after a severe contest was chosen Speaker. In 1860 he was again nominated for Congress, but was defeated.

*Feb. 19.*—WHITE, HON. JOEL W., died at his residence in New York, aged 64. He was born in Connecticut, and was connected with the banking institutions of that State, either as cashier or president, for more than 40 years. He was for many years president of the Norwich and Worcester railroad; was appointed consul at Liverpool in 1843; and in 1857 accepted the position of consul at Lyons, France.

*Feb. 20.*—APPLETON, HON. WILLIAM, died in Boston, Mass. He was born in 1786; was a prominent merchant in Boston, and served several terms in Congress.

*Feb. 26.*—FELTON, CORNELIUS CONWAY, LL.D. (See FELTON.)

*March 2.*—LANDER, Brig.-Gen. FREDERICK WM. (See LANDER.)

*March 5.*—SMITH, REV. DAVID, D.D., died in New Haven, Conn. He was born in Bozrah, New London county, Conn., Dec. 18, 1767; graduated at Yale College in 1795; studied theology, and in 1799 was ordained pastor of the Congregational church in Durham, Conn., succeeding the Rev. Elizur Goodrich, D.D. In 1821 he was elected one of the fellows of Yale College, and held this position forty years, when he tendered his resignation.

*March 7.*—McCULLOCH, GEN. B. (See McCULLOCH.)

*March 8.*—BOONE, ENOCH, died in Meade

county, Ky., aged 84 years. He was a son of Daniel Boone, and the first white male child born in Kentucky.

*March 9.*—**DE WOLF, JOHN**, died in Bristol, R. I., aged 76 years. From 1817 to 1884 he was professor of chemistry in Brown University, Providence, R. I.

*March 18.*—**HATCH, DANIEL GILMAN**, died in Exeter, N. H. He was born in that place, Aug. 8, 1798, graduated at Harvard College in 1817, and for nearly 20 years devoted himself to the profession of teaching in Virginia. He was a member of the Virginia Convention in 1829. In 1837 he removed to Georgetown, Ky., and turned his attention to commercial pursuits, though his interest in the cause of education continued, and until his death he held offices in connection with the college in that place. He also manifested unwearied zeal in finding positions as teachers for young men and women from the east. About ten years previous to his death he was chosen cashier of the Commercial Bank at Harrodsburg, and afterward to a similar position in Covington, in each of which he displayed uncommon financial ability. His death occurred during a visit to his native place, consequent upon the loss of his parents.

*March 14.*—**MEADE, Rt. Rev. WM., D.D.** (*See MEADE.*)

*March 18.*—**WHEATON, NATHANIEL SHELDON, D.D.**, died in Marbledale, Washington, Conn. He was born in that town, Aug. 20, 1792, graduated at Yale College in 1814, pursued a course of theological study in Maryland, and in 1818 was chosen rector of Christ Church, Hartford, Conn. In 1831 he resigned the rectorship to fill the appointment of President of Trinity, then Washington College, Hartford, succeeding Bishop Brownell, and during his administration of six years raised the sum of \$40,000 for its maintenance. In 1837 he resigned the presidency to accept the rectorship of Christ church, New Orleans, where he labored with fidelity seven years. He twice visited Europe, and was the author of a volume entitled "Journal of a Residence in London, and of Tours in England, Scotland, and France." At his death he bequeathed to Trinity College the sum of \$20,000.

*March 25.*—**COFFING, Rev. JACKSON G.**, a Presbyterian missionary in Central Turkey, died at the house of the American consul at Alexandretta from a wound received by robbers.

*March 30.*—**ROLPH, JOHN A.**, a distinguished artist and landscape engraver, died in Brooklyn, E. D. (Williamsburg), N. Y., in the 64th year of his age. He was born in Essex, England, but in 1833 emigrated with his family to America, and had resided in New York most of the time since that period. Some fine specimens of his artistic ability may be found in "Wilkes's Exploring Expedition." He was an uncle of Edward Miall, M.P., the great radical writer (now editor of "The Non-Conformist"), and father of the well known singer Mrs. Clara M. Brinkerhoff.

*April 1.*—**EDWARDS, OGDEN**, died at his residence in Staten Island, N. Y. He was born in Connecticut in 1781, and was a son of Pierpont Edwards, and grandson of Jonathan Edwards, and inherited great strength of intellect and will. He made his home in New York in the early part of this century, and was for many years surrogate of the city. He was afterward a member of the State Legislature, and in 1821 was a member of the convention to revise the Constitution of the State. He was circuit judge of the supreme court, and continued in that office until he reached the age limited by the constitution. He was at one time a candidate of the whig party for governor.

*April 1.*—**DOHENY, Col. MICHAEL**, a distinguished orator, died at his residence in Brooklyn, N. Y. He was one of the leaders of the Irish revolutionary movement of 1848, practised law in New York, and for a time edited a newspaper.

*April 6.*—**O'BRIEN, Lieut. FITZ JAMES**, died in Virginia, aged 33 years. He was born in Ireland, and came to this country about 1850. He was a brilliant writer, and also a poet of much merit. In April, 1861, upon the call for troops, he enlisted in the 7th regiment New York State militia, and in Jan. 1862, accepted an appointment upon the staff of Gen. Lander, and in the short time of service prior to his death, distinguished himself as an officer of courage and daring. He was wounded in a skirmish on Feb. 16, and died from tetanus, following a severe surgical operation, which he bore with great fortitude.

*April 6.*—**PEABODY, Col. EVERETT**, of the 25th Missouri regiment, was killed in the battle of Shiloh. He was born in Springfield, Mass., June 13, 1830, graduated at Harvard College in 1849, and adopted civil engineering as a profession, in which he rapidly distinguished himself. He was employed upon various railroads at the West, and in 1859 was chief engineer of the Platte county railroad. When the war broke out he raised a battalion, was commissioned major, and employed in repairing and defending the railway communications of northern Missouri. He commanded 1,200 men at the siege of Lexington, and received a wound, which lamed him for life, notwithstanding which he reorganized his regiment, and upon joining Gen. Grant's army was assigned the command of a brigade under Gen. Prentiss on the exposed left wing, nearest the enemy, where in the unequal conflict he was killed.

*April 6.*—**JOHNSTON, Gen. ALBERT SIDNEY.** (*See JOHNSTON, A. S.*)

*April 7.*—**TOMPKINS, ABEL**, a well known publisher in Boston; was born in that city, June 22, 1810. He was by trade a bookbinder, and in 1836 purchased the "Ladies Repository," opened a small book store, and soon became an extensive publisher, especially of the denominational books of the Universalists, and of

several of their periodicals. He was a man of exquisite taste, and the "Rose of Sharon," a gift book or annual published by him, was long regarded as a model of artistic beauty in its typography and illustrations. He was much esteemed both in his public and social life.

*April 7.*—**PEGRAM**, Col. **WILLIAM**, was killed at the battle of Shiloh, Tenn. He was born in Virginia, but had resided for many years in Kentucky. Though a brother of Robert Pegram, commander of the Confederate steamer Nashville, he was a staunch loyalist, and raised a regiment of cavalry which was in the engagement at Pittsburg Landing. At the time of his death he was acting brigadier-general.

*April 8.*—**FLETCHER**, Prof. **MILES J.**, of the Indiana Asbury University, Greencastle, Ind., and State Superintendent of Public Instruction, was killed while on his way to aid the wounded, after the battle of Shiloh. He was a man of superior attainments, and of earnest loyalty and patriotism. During a part of the previous year he had added to his other duties that of assistant adjutant-general. In his Message of Jan. 1863, Gov. Morton paid a tribute to his many virtues and excellencies.

*April 10.*—**WALLACE**, Gen. **WM. HARVEY LAMB**, died at Savannah, Tenn., from a wound received at the battle of Shiloh. He was born in Urbana, Ohio, July 8, 1821, was educated for the law, served in the Mexican War, and in 1853 was elected State attorney for the ninth judicial circuit of Illinois. He held command of the 11th regiment of Illinois volunteers, and joined the depot at Cairo during the early stages of the war. He held a command in the troops sent to attack Fort Henry, and distinguished himself in the siege of Fort Donelson, where he commanded a brigade in Gen. McClelland's division of Gen. Grant's army. For his gallantry upon that occasion he was made by Congress, on the 21st of March, a full brigadier-general, and with that rank went with the expedition up the Tennessee river.

*April 12.*—**FRELINGHUYSEN**, Hon. **THEODORE**, LL.D. (See **FRELINGHUYSEN**.)

*April 16.*—**WHEELER**, **JOHN**, D.D., President of the University of Vermont, died in Burlington, Vt. He was born in 1798 at Oxford, N. H., and graduated at Dartmouth College in 1816. He was twice elected president of the University of Vermont, and officiated in that capacity from 1842 to 1855.

*April 18.*—**PEET**, **DUDLEY**, M.D., died in New York city. He was born in Hartford, Conn., July 9, 1830, graduated at Yale College in 1852, studied medicine in the College of Physicians and Surgeons in New York, and for a short time pursued the practice of his profession in the city. In 1857 he removed to Burlington, Iowa, and after two years' practice returned, and became associated with his brothers as an instructor in the New York Institution for the Deaf and Dumb, under the superintendence of his father, Dr. Harvey P. Peet. He was well fitted for this work, and during the

three years previous to his death was eminently successful.

*April 19.*—**HARVEY**, **LOUIS P.**, governor of Wisconsin, was drowned at Savannah, Tenn., while on his way to Pittsburg with supplies for the wounded after the battle of Shiloh. He was born at East Haddam, Conn., July 22, 1820, in 1828 removed with his parents to Ohio, and was educated at the Western Reserve College. In 1840 he became a resident of Kenosha, Wis., where he engaged as a teacher in the academy, and later assumed the editorship of the Whig newspaper, published in that city. In 1850 he removed to Shopiere, Rock county, where he engaged in the manufacturing business. He was a member of the first Constitutional Convention, and represented Rock county in the Senate from 1855 to 1857, when he was elected secretary of State, and in Nov. 1861, governor.

*April 25.*—**SMITH**, Gen. **CHARLES FERGUSON**. (See **SMITH**, Gen. C. F.)

*April 26.*—**PALMER**, **ROBERT M.**, United States Minister to the Argentine Confederation, died at sea aged 41 years. He was born at Mount Holly, New Jersey, in 1820, and was a son of the Hon. Strange N. Palmer, of Pennsylvania. In 1830 he removed with his father's family to Pottsville, Schuylkill county, where he was educated as a printer. He subsequently became an editor, studied law, and in 1845 was admitted to the bar. In 1850 he was elected district attorney in Schuylkill county, and subsequently was speaker in the State Senate. In May, 1861, he left home to enter upon his duties as minister at Buenos Ayres, but his health, which had for some time been failing, compelled him to resign his office, and he died on his return homeward.

*April 27.*—**BETHUNE**, **GEORGE W.**, D.D. (See **BETHUNE**, G. W.)

*April 29.*—**ALLEY**, **JOHN BURROUGHS**, M.D., died in Boston, aged 41 years. He graduated at Yale College in 1840, and at the Medical School of Harvard University in 1844, after which he spent two years in Europe, pursuing his medical studies. Upon his return he settled in Boston, and until his death was an active and useful member of his profession. He was for several years superintendent of the Boston Dispensary, and, for a time, one of the councillors of the Massachusetts Medical Society.

*April 30.*—**CAMBRELENG**, Hon. **CHURCHILL C.**, died at his residence near Huntington, Long Island. He was born in North Carolina in 1786, and was educated at Newbern. In 1802 he came to New York, and subsequently went to Providence, R. I., where he was employed as a clerk. He was next employed by John Jacob Astor, and while in his service travelled extensively. He was a member of Congress from New York, from 1821 to 1839, during which time he acted as chairman of Committees of Commerce, Ways and Means, and Foreign Affairs. In 1839 he was appointed Minister to Russia by President Van Buren, and in 1846 was a member of the State Constitutional Convention.



*May 8.*—**BANGS, NATHAN, D.D.** an eminent Methodist clergyman, died in New York. He was born in Stratford, Conn., May 2, 1788. The years of his early manhood were occupied with school teaching and land surveying. In 1800 he became a member of the Methodist Episcopal Church, and in 1801 entered the itinerant ministry in that church. His first appointments were in Lower and Upper Canada, and it was not till 1808 that he received a circuit in the Albany district, in the United States; and the same year he was appointed a member of the General Conference. In 1810 he received his first appointment in New York city, and for the next ten years he was called to fill the most important appointments in the church. In 1820 he was elected to the agency of the Methodist Book Concern, and the general editorship of its publications. He served in this capacity for eight years, and then for four years editor of the church organ, the "Christian Advocate and Journal," and for the four years following, of the "Methodist Quarterly Review." In 1836 he was chosen Corresponding Secretary of the Methodist Missionary Society, and remained in that position till 1841, when he was elected President of Wesleyan University, Middletown, but resigned in 1842, and entered once more upon the active duties of the ministry, in New York and Brooklyn, in which he continued for ten years. His health becoming infirm, he took a supernumerary relation in 1852, but preached occasionally, till the last two or three years of his life. Amid his often abundant labors, Dr. Bangs found time for the preparation of numerous works for the press, some of them controversial in character. Fourteen or fifteen of these are yet in circulation. One of the most important and elaborate of these is a "History of the Methodist Episcopal Church," in 4 vols. 12mo.

*May 4.*—**SNELL, THOMAS, D.D.**, a Congregational clergyman, died at North Brookfield, Mass., aged 88 years. He was a native of Massachusetts, graduated at Dartmouth College in 1795, and was pastor of the Congregational church at Brookfield for more than fifty years.

*May 6.*—**THOREAU, HENRY D.**, died at Concord, Mass. He was born in Boston, July 12, 1817, graduated at Harvard College in 1837, and spent the three following years in teaching. For some time he was a member of the family of Ralph Waldo Emerson, in Concord. He was eccentric in his habits, and nearly every year made an excursion on foot through the woods and mountains of Maine, New Hampshire, New York, and other places, and for more than two years lived in a hut about a mile and a half from Concord, built by himself at an expense of about \$28, supporting himself as a surveyor, pencil maker, &c. He was well known to the public as the author of "A Week on the Concord and Merrimack Rivers," published in 1849, and "Life in the Woods," published in 1854. Early in 1863 two posthumous works from his pen were also issued.

*May 8.*—**BAILEY, GOLDSMITH F.**, a member of Congress, died at his residence, in Fitchburg, Mass. He was first elected in 1860.

*May 11.*—**MACAULEY, Rev. THOMAS, D.D.**, LL.D., a Presbyterian clergyman, died in New York city, aged 85 years. He was formerly a professor in Union College, and subsequently pastor of the Presbyterian church in Murray street, New York.

*May 11.*—**VINTON, Hon. SAMUEL F.**, died in Washington, D. C. He was born at South Hadley, Mass., Sept. 25, 1792, graduated at Williams College in 1814, studied law, and subsequently removed to Ohio. He was for many years a member of Congress, and in 1862 was appointed one of the commissioners under the act abolishing slavery in the District of Columbia. He was a man of ability, and during his long term of service in Congress was respected and beloved.

*May 12.*—**MIGGS, Rev. BENJAMIN CLARK, D.D.**, a missionary of the American Board in Ceylon, died in New York, aged 72 years. He was a native of Connecticut, graduated at Yale College in 1809, and received his theological education in the seminary at Andover. He was one of the founders of the Ceylon mission of the American Board, and having been ordained, embarked for that island in 1815, being one of the second company of missionaries sent out from this country. In 1841 he made a brief visit to his native country, and in 1858, after forty-two years' service, retired from the field.

*May 15.*—**TRACY, Rev. E. C.**, a Congregational clergyman, died in Windsor, Vt., aged 66 years. He was editor of the "Vermont Chronicle," and previously, for several years, of the "Boston Recorder."

*May 18.*—**KEM, Gen. Wm. H.**, died at Harrisburg, Pa., aged about 49 years. He was for several years a militia general and in 1859 was elected surveyor general of the State. At the commencement of the present war he accepted the position of major-general from Gov. Curtin, and was in Gen. Patterson's division on the Upper Potomac during the three months' service. In the fall of 1861 he was appointed a brigadier-general by the President, and joined McClellan's division, where a brigade, consisting chiefly of Pennsylvania regiments, was placed under his command. He died of a combined attack of typhoid fever and dysentery.

*May 18.*—**SCOTT, WILLIAM**, formerly Judge of the Supreme Court of Missouri, died in Jefferson City, Mo. He had a high reputation as an able jurist.

*May 20.*—**BALDWIN, JAMES FOWLE**, died suddenly in Boston, aged 80 years. He was a native of Massachusetts, where he received a thorough academical education and prepared himself for mercantile life, but imbibing from his father and brother a taste for engineering, he joined the latter in the construction of the Dry Dock at the Charlestown Navy Yard. In 1828 he was one of the State Commissioners for the survey of the Western railroad. In

1832 he surveyed the location of the Boston and Lowell railroad, and in 1837 was appointed one of the commissioners to examine and report upon the means of supplying Boston with water, and his plan, though at first rejected, was finally adopted March 30, 1846. He was elected Senator for Suffolk county, and held the office until his appointment as water commissioner. He was a member of the American Academy of Arts and Sciences.

*May 20.*—SHERMAN, JAMES TUTTLE, died in Trenton, New Jersey, aged 47 years, graduated at Yale College in 1838, studied law, and was associated with his father as editor of the "State Gazette" until 1853. He was an active friend of the State Normal School at Trenton.

*May 20.*—BROWNELL, CHARLES CLARENCE, M. D., died in Egypt. He was a native of Connecticut, graduated at Trinity College, Hartford, and at the Medical School, New Haven. At the time of his death he was connected with Mr. Petherick's expedition in search of the head waters of the Nile. He was a man of much intelligence and enthusiasm in the pursuit of science.

*May 26.*—CONDIOT, LEWIS, M. D., a prominent politician of New Jersey, died at Morristown, N. J. He was born in 1772, was high sheriff of Morris county, prior to the commencement of the present century, and from 1805 to 1810 served as a member of the State Legislature, officiating two terms as Speaker of the House. He was one of the commissioners for settling the boundary between New York and New Jersey. He was subsequently elected to Congress, and continued to hold his seat there for upward of twenty years.

*June 1.*—RIPPET, COL. OLIVER H., of the 61st Pennsylvania regiment, killed in the battle before Richmond. He was born in Pittsburg in 1826, studied law under Bushrod Washington, Esq., served in the Mexican War, and upon his return resumed the practice of his profession, for which he possessed talents of the first order. As a soldier he possessed every necessary element, courage, endurance, and faith.

*June 1.*—MILLER, COL. JAMES, of the 81st Pennsylvania regiment of volunteers, was killed in the action before Richmond. He was for many years a resident of Easton, Pennsylvania, but more recently of Yorkville, New York city. At the commencement of the Mexican War he raised a company of volunteers, who formed a part of one of the regiments with Gen. Scott in the campaign to the city of Mexico. For his gallantry during the war he was promoted to a captaincy.

*June 4.*—GOODRICH, REV. CHARLES A., died in Hartford, aged 72 years. He was descended on the paternal side from the Rev. Dr. Chauncey Goodrich, of Durham, Conn., and on the maternal from Col. John Ely, of Saybrook, well known in the Revolutionary War. He graduated at Yale College in 1812, studied theology with Dr. Yates of East Hartford, and in 1816 was ordained and installed pastor of the First Congrega-

tional church in Worcester, Mass., where he remained four years. In 1820 he returned to his native State and settled in Berlin, and in 1848 at Hartford. He was associated with his brother, S. G. Goodrich (Peter Parley), in preparing books for the young, and also published independently several volumes, among which are a "Bible History of Prayer," "Lives of the Signers of the Declaration of Independence," "Great Events of American History," "Universal Traveller," "History of the United States" and "Outlines of Geography." He was at one time a member of the Senate, and held other offices of trust.

*June 5.*—GOODMAN, REV. EPAPHRAS, died at his residence in Chicago. He was born in 1790, had been a pastor of several New England churches, and for several years editor of the "Christian Herald" in Cincinnati.

*June 5.*—DRAKE, COL. ALBERT WALDO, died in South Windsor, Conn., aged 27 years. He entered the junior class in Yale after having been a member of Williams College, and graduated in 1857, studied law in Hartford and New Haven, and was admitted to the bar in 1859, in which year he was a member of the Connecticut House of Representatives. He afterward commenced the practice of his profession in Hartford. At the beginning of the present war he was commissioned as first lieutenant of the 1st Connecticut volunteers, and distinguished himself with honor in the battle of Bull Run. He was subsequently appointed by the governor, lieutenant-col. of the 10th Connecticut volunteers, and as such was engaged in the battle of Roanoke Island. He took part also in the capture of Newbern, and was then appointed colonel of his regiment.

*June 6.*—ASHBY, GEN. TURNER, an officer in the Confederate service, was killed in an engagement near Harrisonburg, Va., aged about 38 years. He was a Virginian by birth. In May, 1862, he was appointed a brigadier-general, and led the vanguard of Gen. Jackson's army in the Shenandoah Valley, during the pursuit of Gen. Banks. He was an officer of great courage and daring.

*June 8.*—BALDWIN, ABRAHAM DUDLEY, died in Greenfield, Conn. He was born in 1788, graduated at Yale College in 1807, and studied law but did not enter upon its practice, devoting himself mostly to agricultural pursuits. He was several times a member of the House of Representatives and also of the Senate of Connecticut, and while a Senator was a member of the corporation of Yale College.

*June 10.*—BOSWORTH, HON. ALFRED, one of the associate judges of the supreme court of Rhode Island, died in Warren, R. I.

*June 10.*—SCOTT, MRS. MARIA MAYO, wife of Lieut.-Gen. Winfield Scott, died at Rome, Italy, aged 78 years. She was a native of Virginia.

*June 11.*—HERRICK, EDWARD CLAUDIUS, died in New Haven, Conn., aged 51 years. He was born in New Haven, and was a son of Rev. Claudius Herrick, a prominent teacher of that

city and a graduate of Yale college in the class of 1798. Young Herrick received a good academical education, and while yet a youth became a clerk in the well known book store of Gen. Hezekiah Howe, upon the death of whom he was for a short time in business as a bookseller on his own account. In 1843 he was appointed librarian of Yale College, and continued to discharge the duties of that office until his resignation in 1858. In 1852 he was appointed treasurer, which post he held until his death. His devotion to the interests of the college was ever active and thorough, and by no means confined to his official trusts. Since the death of Prof. Kingsley in 1852 he had had the chief charge of the triennial catalogue, had prepared the annual record of deceased graduates, and collected much information respecting the biographies of early graduates. The supervision of the college property also formed a portion of his cares. He held many important trusts in connection with municipal affairs, and was considered the most active man in town. Notwithstanding his many duties he made high attainments in various departments of science, devoting much attention to entomology, astronomy, and meteorology. The "American Journal of Science" contains many valuable articles from his pen. Among these an essay on the "Hessian Fly and its Parasites," the result of nine years' careful investigation, and papers on the Meteoric Showers of August and the existence of a planet between Mercury and the Sun, are the most remarkable. His knowledge of local history, general literature, and bibliography was very extensive and always at command. He received an appointment as a member of the U. S. Exploring Expedition under Capt. Wilkes, but declined the honor, mainly, it is believed, from considerations of filial duty to his aged mother.

June 18.—PERRY, Col. JAMES H., D. D., died of apoplexy at Fort Pulaski, Georgia, aged about 51 years. He was educated at West Point, served in the Texan War of Independence and through the Mexican campaign. At the commencement of the present war he was pastor of the Pacific street M. E. church at Brooklyn, N. Y., but from love of his country, and a sense of duty, resigned the pastorate of the church, and raised a regiment called the Continental Guards, which was accepted as the 48th N. Y. State volunteers. This regiment formed part of Gen. Sherman's Port Royal expedition. At the time of his death he had command of Fort Pulaski.

June 21.—ELLET, Col. CHARLES. (See ELLET, C.)

June 27.—HOPKINS, JOSIAH, D. D., a Presbyterian clergyman, died at Geneva, N. Y. He was born in Pittsford, Vt., April 25, 1786, studied the ordinary branches of an English education, and afterward theology with the minister of his parish, and subsequently with Rev. Samuel Haynes, the celebrated colored preacher, and was licensed as a Congregational

preacher in 1810, and after a year's labor as a missionary in western Vermont settled as a pastor at New Haven, Conn., in 1811, and remained there 19 years, teaching theology most of the time in addition to his pastoral duties. He prepared for his classes while residing there "The Christian Institute," a theological text book, which passed through many editions. In 1830 he accepted the pastorate of the 1st Presbyterian church in Auburn, N. Y., which he filled with great acceptancy. In 1848 he resigned in consequence of ill health, and removed to Ohio, and having after some years recovered his health, returned to the vicinity of Auburn, but his disease (asthma) returning, he sought relief at the water cure at Geneva, where he died.

June 27.—TUCKER, Col. ISAAC M., of the 2d New Jersey regiment, was killed in the battle of Gaines' Mill. He was a resident of Newark, N. J., a member of the legal profession, and a man of much influence throughout the State. In 1856 he was a member of the State Republican Executive Committee. He was a true patriot, and his services to his regiment were most valuable. He was shot by the enemy while being borne wounded from the field.

June 30.—BAILEY, Col. GUILFORD D., was killed at the battle of the Seven Pines, aged 28 years. He was a native of New York, graduated at West Point in 1856, and was appointed to artillery service. Soon after his graduation he was ordered to Florida, and after a short service there was assigned to Forts Mackinaw, Snelling, and Leavenworth successively. When secession began he was in Texas, where he refused peremptorily to be included in Twiggs's surrender in 1861. Coming North, he was sent with Major Hunt's battery to reinforce Fort Pickens. Subsequently he raised a volunteer regiment in the northern part of New Jersey, and joined the army of the Potomac, participating in all the battles until as chief of artillery in Gen. Casey's division he was mortally wounded.

June —.—MERRIAM, Rev. W. W., a missionary of the American Board, was assassinated by robbers near Philippopolis, Turkey, upon his return from a missionary meeting at Constantinople. His wife, who accompanied him, died a few days after of typhus fever brought on by grief and overexertion in guarding and conveying home the remains of her husband.

July 6.—SUSINI, Mrs. ISABELLA HINCKLEY, a popular vocalist, died in New York. She was a daughter of the late Dr. Hinckley, a practicing physician of Albany. She early manifested a taste for music, and her voice being an excellent soprano, great care was spent upon her education in that art. At the age of 17 she was taken to Italy, where for two years she studied under the best lyrical and dramatic masters, after which she appeared in Italian opera in several European capitals, and upon her return to this country, in several American cities, everywhere being received with great favor.

She married Signor Susini a little less than a year previous to her death.

July 6.—**MACKENZIE, CHARLES KENNETH**, burned to death at the destructive fire of the Rainbow Hotel, Beekman street, N. Y., aged 74 years. He was for a time in early life aide-de-camp and military secretary to the Duke of Wellington. He was a man of good family and connections, a ripe scholar, and an excellent linguist, with great and versatile literary attainments, having been a contributor to the *Edinburgh* and *Quarterly Reviews*, and the *Encyclopaedia Britannica*, and also at a later period the leading writer of editorials for the London daily conservative journals.

July 8.—**RIPLEY, HON. PHILIP**, ex-mayor of Hartford, Conn., died at his residence in that city, aged 68 years. He was for many years at the head of an extensive iron foundry at the falls in the Connecticut at Windsor Locks, and had been identified with most of the great business enterprises of the city. He was twice elected mayor. A man of philanthropic disposition, he had taken an active part in the establishment of the State Normal and State Reform Schools, and had been one of the trustees of the latter from its organization.

July 11.—**FOULKROD, JOHN**, died in Philadelphia. He served in the war of 1812, and at a later period in life was a member of the House of Representatives and Senate, and of the Reform Convention for the adoption of the new Constitution. He was also, by appointment of the Supreme Court, a member of the Board of Prison Inspectors.

July 24.—**VAN BUREN, MARTIN**. (See VAN BUREN.)

July 24.—**MUDGE, Prof. T. A.**, late of McKendree College, and pastor of Baldwin City Station, in the Kansas Conference, died in the college building while engaged in his study.

July 24.—**MILNOR, WILLIAM HENRY, M.D.**, surgeon in the army, died at Savage's Station, near Richmond, Va., aged about 60 years. He was a son of the late Rev. Dr. Milnor, and at the time of his death Past Grand Master of the Masonic Order in the State of New York.

July 25.—**WALLACE, BENJAMIN J., D.D.**, died at Philadelphia, aged 52 years. He was a native of Philadelphia, a cadet at West Point from 1827 to 1830, passed through a theological course at Princeton, N. J., and subsequently had charge of various churches in the States of Pennsylvania and Kentucky. He was for a time professor in Delaware College, Newark, Del. In 1850 he removed to Philadelphia, and assumed the editorship of the "Presbyterian Quarterly Review" from its commencement.

July 25.—**WILLIAMS, REUEL, LL.D.**, died at Augusta, Me., aged 79 years. He was a native of Maine, an able member of the legal profession, served in both branches of the State Legislature, and six years as a Senator in Congress.

Aug. 1.—**THORNWELL, JAMES HENRY, D.D.**, an eminent Presbyterian clergyman, died at Char-

lotte, N. C. He was born in Marlborough District, S. C., in 1811, graduated at South Carolina College (Columbia, S. C.), in 1829, and soon after commenced the study of law, but after a time abandoned it for theology, and having passed through the usual course of study, commenced his ministerial career as the pastor of the Waxhaw Presbyterian church. In 1836 he was elected professor of logic and belles lettres in South Carolina College; but in 1838 resigned to become pastor of the Presbyterian church in Columbia. In 1840 he accepted the professorship of the Evidences of Christianity, and the chaplaincy of the college, and held it till May, 1852, when he accepted a call to the pastorate of the Glebe street Presbyterian church in Charleston. In December of the same year he was recalled to Columbia to take the presidency of the college, with which he had been so long connected. In 1856 he resigned at the call of the General Assembly of the Presbyterian Church (O. S.), to take the senior professorship of the Presbyterian Theological Seminary at Columbia, which he held until his death. In his native State perhaps no man wielded a more powerful influence than Dr. Thornwell. John C. Calhoun, whom, in intellectual form and character he strongly resembled, pronounced him the greatest man of his acquaintance, and the position he held in the General Assembly of his church, showed that the statesman's judgment of him was not far wrong. He was an ardent and uncompromising advocate of slavery, and encouraged the secession movement to the utmost of his power both with pen and voice. He opened the first session of the Secession Convention of South Carolina with prayer. Amid his other duties Dr. Thornwell had been a somewhat prolific writer. His published sermons, addresses, essays, and occasional pamphlets are very numerous; the latest of them was a sermon elaborately defending secession. He had also published two volumes, "Arguments of Romanists Discussed and Refuted" (New York, 1845), and "Discourses on Truth" (New York, 1854).

Aug. 5.—**McCook, Brig.-Gen. ROBERT L.**, an officer in the Union service, shot by guerillas near Salem, Alabama. He was a native of Jefferson county, Ohio, born in 1827. He was a man of fine attainments, and had early chosen the legal profession. He studied law in Columbus, and opened an office in that city when he was only 21 years of age. A few years later he removed to Cincinnati, where he had acquired a large practice. At the first call for troops he raised a regiment of Germans for the war. During the two months that his regiment was in camp in Ohio, he had drilled them into a high state of perfection. In the campaign of western Virginia in the summer and autumn of 1861 McCook and his "bully Dutchmen," as his regiment was called, were constantly on the alert, and at Rich Mountain, Cheat Mountain, in the various skirmishes on and near the line of the Balti-

more and Ohio railroad, and at Carnifex Ferry, the skill, bravery, and daring of the commander, and the invincibility of the troops, were fully tested. Early in the winter Col. McCook was ordered with his command to Kentucky, and at Mill Springs the impetuosity of his regiment in their charge upon the enemy carried the day. Col. McCook was wounded in the engagement, but only remained away from his regiment long enough to recover sufficient strength to ride on horseback. For his gallant conduct at Mill Springs he was promoted to a brigadier-generalship, the Senate unanimously confirming the nomination, but he was so strongly attached to his "bully Dutchmen," and they were so unwilling to have any other commander, that he never accepted the commission. He joined Gen. Buell's command after the evacuation of Bowling Green, but was not in any of the subsequent battles. At the time of the attack on him he was very sick, and was carried in an ambulance, one regiment and part of another of his brigade being in advance, and the remainder some distance in the rear. The guerillas, who were partly residents of the vicinity, had been informed that he was to pass, and knowing his helpless condition, had lain in ambush for him while the regiments in advance passed. They came upon his escort in large force, overturned the ambulance, and shot him down in cold blood. His faithful driver and attendant bore him to the nearest house. He survived, though in terrible suffering, about 24 hours. His regiment, learning of the death of their commander, visited the scene, and seizing some of the guerillas, hung them at once, and destroyed their houses. The McCook family have contributed more men to the war, probably, than any other in the United States. Maj.-Gen. Alexander McDowell McCook was a brother of the murdered general, and sixteen members of the family have been either in the army or navy.

*Aug. 5.*—WILLIAMS, Brig.-Gen. THOMAS, an officer of the U. S. army, killed in the battle of Baton Rouge, La. He was a native of New York, born in 1818, was appointed a cadet at West Point from Michigan in 1833, and graduated in 1837; received the appointment of brevet second lieutenant in the Fourth Artillery during the same year; in 1840-'41 was acting assistant professor of mathematics at West Point, in 1844 was appointed an aide-de-camp on Gen. Scott's staff, and in the Mexican war won the brevets of captain and major for gallantry and meritorious conduct. He was promoted to a captaincy in 1850, and commissioned major in the 5th artillery in May, 1861, and in September of the same year appointed brigadier-general of volunteers. During the autumn of 1861 he commanded the forts at Hatteras Inlet, and when the Ship Island expedition was sent out was assigned to the command of one of the brigades. He commanded the forces in the first unsuccessful attack upon

Vicksburg, projected and superintended the cutting of the canal intended to turn the course of the Mississippi away from Vicksburg; on the failure of this enterprise he was placed in command at Baton Rouge. He repelled with vigor and success the attack of the Confederate general Breckinridge on that place, but just at the close of the engagement, while bringing up a Michigan regiment to charge upon the enemy he was slain. He was an able and skilful officer, and a very rigid disciplinarian.

*Aug. 5.*—ROBERTS, Col. GEORGE T., an officer in the Union service, and commander of the 7th regiment Vermont volunteers, killed at the battle of Baton Rouge, La. He was a native of Rutland, Vt., and the regiment which he commanded was one raised to form part of Gen. Butler's command on the Ship Island expedition. He was commissioned Feb. 12, 1862, and sailed for Ship Island on the 10th of the following month. Col. Roberts participated in the capture of New Orleans, and his regiment suffered severely in the battle of Baton Rouge in which he lost his life.

*Aug. 8.*—GREW, Rev. HENRY, an American clergyman, died in Philadelphia. He was born in England in 1781, but emigrated to this country with his parents at the age of 14, subsequently graduated at Brown University, became a Baptist minister, and for some years was pastor of the First Baptist church in Hartford, Ct. Having adopted views differing from those of that denomination, he resigned the pastorate, and after a time removed to Philadelphia, where he resided the remainder of his life. He was an active friend and promoter of foreign missions, and one of his daughters, Mrs. Eliza Grew Jones, devoted herself to foreign missionary work, and died at Bangkok, Siam, after several years of zealous labor as a missionary. Mr. Grew published several works in defence of the doctrines of the Adventists, whose views he had adopted. He was a man of great benevolence and charity, and few citizens in private life have been more sincerely and generally regretted.

*Aug. 9.*—ORAN, Lieut.-Col. L. H. D., an officer in the Union service, at the time of his death acting colonel of the 8d regiment, Wisconsin volunteers, killed at the battle of Cedar or Slaughter Mountain. He was a citizen of Ripon, Wisconsin, and had been for several years chief clerk of the Assembly of that State. He joined the regiment as major, but was soon promoted to the lieutenant-colonelcy, and at the time of the battle, owing to the illness of the colonel, was in actual command of the regiment. He was a genial, intelligent, and amiable man, beloved in his own neighborhood and State.

*Aug. 9.*—SEWELL, WILLIAM GRANT, a prominent *littérateur*, died in Quebec, Lower Canada, of pulmonary consumption. He was born in Quebec in 1829, and was a grandson of the late Jonathan Sewell, chief justice of Lower Canada. Young Sewell was educated for the

bar, but preferred editorial life, and in his 24th year became connected with the New York daily press, a connection which, either as editor or correspondent, he maintained till his death. For some time he was one of the principal editors of the "N. Y. Daily Times." Some years ago his health compelled him to spend several winters in the West Indies, and as a result of his careful and thorough investigations he published a treatise entitled "The Ordeal of Free Labor in the British West Indies."

*Aug. 9.*—BRIGHAM, Rev. JOHN C., D. D., a Presbyterian clergyman, and, since 1827, secretary of the American Bible Society, died in Brooklyn, E. D. (Williamsburg). He was born in 1793 at New Marlborough, Mass., graduated at Williams College in 1819, studied theology at Andover, spent three years in South America in missionary exploration and Bible distribution, and on his return in 1825 became connected with the American Bible Society, of which he was appointed a corresponding secretary, in 1827, a post he filled with ability for thirty-five years.

*Aug. 17.*—VAWTER, Rev. JOHN, a Baptist minister, and one of the pioneer settlers of Indiana, died at Morgantown, Ind. He was a native of Orange (now Madison) county, Virginia, and was born Jan. 8, 1782. He was licensed as a Baptist minister in 1804, and in 1807, in company with his father, removed to the then sparsely inhabited territory of Indiana, selecting for his residence the present township of Madison, of which he was the first magistrate. He was soon after elected sheriff of Jefferson and Clark counties, and in 1810 was appointed by President Madison U. S. marshal for the State. In the Indian campaign of 1811-'13 he served as a frontier ranger, and was afterward (in 1817) elected colonel of the militia of Jennings county, to which he had removed in 1815, and where he founded the county seat Vernon. He was ordained as pastor of the Baptist church in this place in 1821, and continued to preach there until 1848. From 1831 to 1835 he was a member of the Legislature, and in 1836 of the State Senate, where his influence caused the adoption of the policy of internal improvements by the State. In 1848 he removed to Morgan county, and founded Morgantown, erecting several public buildings, among others a neat brick church, which he presented to the Baptist congregation of the town.

*Aug. 22.*—BOHLEN, Gen. HEINRICH, an officer in the Union service, killed while opposing the attempts of the Confederate force to cross the Rappahannock. He was a native of Germany, but emigrated to this country a number of years since and settled in Philadelphia as an importer of wines. At the commencement of the war he raised a regiment of his countrymen (the 75th Pennsylvania), which was subsequently attached to Gen. Blenker's division. He was promoted to a brigadier-generalship April 28, 1862, and attached to the Mountain Department, where

he served under Fremont and Sigel; distinguishing himself for bravery and daring at the battle of Cross Keys. He was a man of devout and exemplary character. His son, Mr. J. B. Bohlen, who was on a visit to his native land, died in Baden-Baden on the same day with his father.

*Aug. 22.*—READ, Rear-Admiral GEO. CAMPBELL, an officer of the American navy, and at the time of his death governor of the naval asylum at Philadelphia, died in that city. He was a native of Ireland, but came to this country at an early age, and entered the navy as a midshipman April 2, 1804. He was third lieutenant on board the Constitution at the time of her fight with the Guerriere in 1812, and was appointed by Commodore Hull to receive the sword of Capt. Dacres of the Guerriere. He was promoted to a captaincy in 1825, and served for several years as commander of the African squadron. He had been placed on the reserved list under the act of 1855, and on the death of Captain Nicholson in 1861 was appointed his successor as governor of the naval asylum.

*Aug. 28.*—ALLYN, Capt. FRANCIS, a prominent citizen of New London, Conn., died at his residence in that city. In early life he was a shipmaster, and was honored with the special friendship of the Marquis de La Fayette, whom he brought to this country in 1824.

*August 25.*—APPLETON, Gen. JAMES, died in Ipswich, Mass., aged 77 years. He was a native of Ipswich, born Feb. 14, 1785. While yet a young man he was for several years elected to the General Court, at a period when Harrison Gray Otis presided over the Senate, and Josiah Quincy was the leader of the House. During the war of 1812 he was a colonel of the militia force, and was in command of the district of Gloucester, and at the close of the war was promoted to the rank of brigadier-general. He removed not long after the war to Portland, Me., and there was a member of the Legislature and for several years the candidate of his party for governor. In 1853 he returned to the home of his childhood, and there passed the remainder of his days. He had been from the beginning an earnest advocate of the temperance and anti-slavery causes, and had aided both by pen and voice.

*Aug. 27.*—WEBSTER, Col. FLETCHER, an officer of volunteers in the Union service, and at the time of his death colonel of the 12th regiment Massachusetts volunteers, died at Alexandria of wounds received in the second battle of Bull Run. He was the oldest son of Daniel Webster, and was born at Portsmouth, N. H., in 1812. He was educated at Dartmouth College, and served as Assistant Secretary of State under his father during the administrations of Presidents Harrison and Tyler. When Caleb Cushing went to China as American commissioner, Mr. Webster accompanied him as Secretary of Legation. Under the administrations of Presidents Pierce and Buchanan he held

a position in the Boston custom house. When the call was made for troops in the spring of 1861, he was among the first to raise a regiment for the war, and was in active service till his death. He was shot through the lungs, and died of hemorrhage in a few hours. He was the last member of his family, a brother and sister having previously deceased.

*Aug. 28.*—MEANS, Col. ISAAC H., ex-governor of South Carolina, killed at the second battle of Bull Run. He was a colonel in the Confederate service.

*Aug. 30.*—CULL, Rev. HUGH, an aged and eminent clergyman of the Methodist Church, died near Richmond, Indiana, in the 105th year of his age. He had been for nearly sixty years a local preacher.

*Aug. 30.*—PRATT, Col. GEORGE W., an officer of the Union service, and at the time of his death colonel of the 20th regiment N. Y. State volunteers, was killed at the battle near Gainesville, Va. He was the son of Col. Zadock Pratt, formerly M. C. from Greene county, and had entered the volunteer service in the summer of 1861. He was an excellent officer and highly esteemed in private life. He was killed while leading his men in a charge.

*Aug. 30.*—KOLTES, Col. JOHN A., an officer in the Union service, and at the time of his death acting brigadier-general in Gen. Steinwehr's division, killed at the battle of Gainesville, Va. He was a native of Rhenish Prussia, born in 1823, and came to this country in 1846. In Prussia, he had been a professor in one of the gymnasia, or colleges. Shortly after his arrival here he joined a regiment from Pennsylvania, which had volunteered for the Mexican War, and served throughout that war as orderly sergeant. After the close of the war he was for a time an officer of the Marine Corps, and was subsequently employed in the U. S. mint at Philadelphia. At the commencement of the present war, he appealed to his countrymen to join him in defence of the Union, and succeeded in raising a regiment of Germans, whom he led to the field. He had been for four months acting brigadier-general in Steinwehr's division, and his friends had secured his promotion to that rank and were carrying his commission to him when they met his dead body, as it was borne from the field.

*Aug. 30.*—CANTWELL, Col. JAMES, an officer of the Union service, and at the time of his death colonel of the 82d Ohio regiment, killed at the battle near Gainesville, while rallying the left wing of his regiment, which had given way under the attack of an overwhelming force of the Confederates. He was a citizen of Kenton, Hardin county, Ohio, and volunteered in the service at the commencement of the war, having been lieutenant-colonel of the 4th Ohio regiment of three months' troops; when they were disbanded he raised the 82d regiment for the war, and received his commission as colonel Dec. 31, 1861.

*Aug. 31.*—BRODHEAD, Col. THORNTON F., an

officer of the Union army, and at the time of his death commander of the 1st Michigan cavalry regiment, died at Alexandria, Va., of wounds received the preceding day at the second battle of Bull Run. He was a native of New Hampshire, born in 1822, and was a son of Rev. John Brodhead, formerly a member of Congress from that State. He studied law at the Harvard Law School, and settled in his profession at Detroit, Mich. He served with distinction in the Mexican War as an officer in the 15th U. S. infantry, and was twice brevetted for gallant conduct in battle. At the close of the war he returned to the practice of his profession, and was soon after elected a member of the State Senate. In 1852 President Pierce appointed him postmaster of Detroit. At the commencement of the war he raised a cavalry regiment, at the head of which he served under Gens. Banks, Fremont and Pope.

*Aug. —.*—AUDUBON, JOHN W., the last of the sons of the celebrated naturalist, died in New York city. He inherited much of his father's taste and talents, and had occupied himself with zoological studies. When taken ill, he was preparing for the press a new and revised edition of his father's "Birds of America."

*Sept. 1.*—STEVENS, Gen. ISAAC INGALLS. (See STEVENS, I. I.)

*Sept. 1.*—KEARNEY, Gen. PHILIP. (See KEARNEY, P.)

*Sept. 1.*—WILLARD, Hon. JOHN, a member of the State Senate of New York, and formerly one of the justices of the supreme court of the State, died at Saratoga, N. Y., of paralysis. He was born in 1792, and in early life identified himself with the democratic party. In 1836 Gov. Marcy appointed him judge and vice chancellor of the fourth circuit court of the State, a position which he held till the adoption of the constitution of 1846. At the judicial election of 1847, he was chosen one of the justices of the supreme court for eight years. At the expiration of his term he resumed the practice of his profession. In the autumn of 1861 he was put in nomination for the State Senate, and received the votes of all parties. He was appointed a member of the Judiciary Committee, and in that capacity prepared the act of 1862 restoring the death penalty, and repealing the former statutes on that subject.

*Sept. 1.*—TAYLOR, Gen. GEORGE B., an officer of the Union army, died in Alexandria of wounds received at the second battle of Bull Run. He was a native of Clinton, Hunterdon county, New Jersey, and was born in 1808. At the age of 19 he entered the navy as a midshipman, but after a three years' cruise settled in New Jersey as a farmer. In the Mexican war he served first as lieutenant, and afterward as captain in the 10th infantry. After the close of that war he resided for three years in California, and then returned to his native State, where he engaged in mining and manufacturing. At the commencement of the present war he

was commissioned as colonel of the 3d New Jersey regiment, which, under Brig.-Gen. Runyon, formed a part of the reserve at Bull Run. When the three months' men were mustered out of the service, he reorganized his regiment and returned to the army, and was attached to the army of the Potomac when it went to the peninsula. After the battle of West Point Gen. Kearney was made a division commander, and Col. Taylor was placed in charge of the 1st brigade of N. J. volunteers. On the 9th of May, 1862, he received his commission as brigadier-general. In the hard fighting that followed before Richmond, he performed his part manfully, and when the army returned to the Potomac, he was prompt and ready with his brigade in the sharp battles southwest of Washington.

*Sept. 6.*—LARNED, COL. BENJAMIN FRANKLIN, paymaster general of the U. S. army, died at Washington. He was born in Massachusetts, in 1791, and on the 21st Oct. 1813, entered the army as ensign in the 21st regiment of infantry; he was promoted to a first lieutenantcy in the summer of 1814, distinguished himself at the defence of Fort Erie, Aug. 18-15 of that year, and received the brevet rank of captain for his gallant conduct. In Jan. 1815, he was appointed regimental paymaster, and on the reduction of the army retained as paymaster of the 5th infantry, with rank and pay of major. In 1847, when two deputy paymaster generalships were created, Major Larned was appointed to one of them with the rank of lieutenant-colonel, and on the death of Maj.-Gen. Towson, in 1854, he succeeded to the paymaster generalship by right of seniority, with the rank of colonel. Regarding it a matter of duty to aid in the work of reorganizing the department over which he presided, for the vast labors which were thrown upon it by the war, he toiled on, though with impaired health, till the office and its duties were completely systematized, when he sunk under the load and his overtasked powers gave way. He was greatly esteemed and beloved by all his acquaintance.

*Sept. 13.*—THOMSON, JOHN R., U. S. Senator from New Jersey, died at Princeton, N. J., after a long illness. He was a native of Philadelphia, born Sept. 25, 1800. He was bred a merchant, and for several years was engaged in the China trade. President Monroe appointed him consul to Canton. He came home in 1825, and soon after married a sister of Commodore Stockton, and settled in Princeton. In 1835 he became a director in the Camden and Amboy railroad, which office he retained till his death. In 1842 he canvassed the State for the Constitutional Convention which met in 1844. In 1844 he was the democratic candidate for governor, but was defeated. In 1853, Com. Stockton having resigned his seat in the Senate, Mr. Thomson was elected for the remainder of the term, and in 1857 reelected for six years. His term would have expired March 4, 1863.

VOL. II.—48 ▲

*Sept. 14.*—MANROSS, NEWTON SPAULDING, Ph. D., acting professor of chemistry at Amherst College, and captain of a company of the 16th Connecticut regiment, was killed at the battle of South Mountain, Md., while leading his company into action. He was born about 1827, graduated from Yale College in 1849, went to Europe and pursued his studies in chemistry, engineering, and mining at the University of Gottingen for the next three years, and took the degree of Ph. D., in 1852. After his return from Europe he was employed in exploring the Isthmus of Panama with reference to the proposed inter-oceanic canal, and visited the West India Islands, exploring the Pitch Lake of Trinidad and other remarkable objects, and contributed to the American "Journal of Science" the results of his observations. In 1861 he was appointed acting professor of chemistry at Amherst College in the absence of Prof. Clark, and in the summer of 1862 accepted the captaincy of a company in the 16th Connecticut volunteers.

*Sept. 14.*—RENO, Maj.-Gen. JESSE L. (See RENO, J. L.)

*Sept. 15.*—TWIGGS, Gen. DAVID EMANUEL. (See TWIGGS, D. E.)

*Sept. 16.*—MILES, Col. DIXON H., an officer of the U. S. army, mortally wounded at Harper's Ferry, Va., by a shell thrown by the enemy after his surrender of the place. He was a native of Maryland, born about 1808, and was appointed a cadet at West Point from that State in 1819. He graduated in 1824, and received an appointment as brevet second lieutenant of the 4th infantry, and the same day was made second lieutenant of the 7th infantry. He was regimental adjutant from 1831 to 1836, and in 1836 was promoted to a captaincy. In Jan. 1839, he was appointed assistant quartermaster on the staff, with rank of captain, but resigned his staff appointment in Sept. 1845. On the 9th of May he was brevetted major for gallant conduct at Fort Brown, Texas; and for his further meritorious conduct at several battles in Mexico, was brevetted lieutenant-colonel. In Feb. 1847, he was promoted as major of the 5th infantry, and in July, 1848, was civil and military governor of Jalapa, Mexico. In April, 1851, he was promoted to the lieutenant-colonelcy of the 8d infantry, and in 1857 and 1858 distinguished himself in several conflicts with the Apache and Navajoe Indians. In Jan. 1859, he was promoted to the colonelcy of the 2d infantry, and at the battle of Bull Run was in charge of the 5th division, and was ordered to cover the retreat. In Sept. 1862, he was intrusted with the command of the important post of Harper's Ferry, the retention and defence of which were essential to the complete success of the battles which followed. He asked for reënforcements, but they were not sent; one of his subordinates abandoned Maryland Heights, which commanded the main position, and finding the enemy approaching in large force,



he surrendered the post with but slight resistance, and with it nearly 14,000 men as prisoners, and an immense amount of arms, ammunition and stores. (See ARMY OPERATIONS.)

*Sept. 17.*—BRANCH, Gen. LAWRENCE O'BRIEN, an officer in the Confederate service, killed at the battle of Antietam. He was a son of Hon. John Branch, formerly governor of North Carolina, and was born in Halifax co. in that State in 1820. He graduated at Nassau Hall College, Princeton, in 1838, studied law with his father, and practised his profession in Raleigh. In 1855 he was elected to Congress from the Raleigh district, and reelected till 1861. After North Carolina passed the ordinance of secession, he entered the Confederate army first as colonel, but was soon promoted to a brigadier-generalship. At the battle of Newbern he had command of that important position, and subsequently took part in several of the battles in that State and on the peninsula.

*Sept. 17.*—MATHESON, Col. RODERICK, an officer of the Union army, and commander of the 82d regiment N. Y. State volunteers (1st California regiment), killed at the battle of Antietam. He was a native of New York, but had resided for several years in California, and in May, 1861, left his home in that State and raised in New York city a regiment of Californians and those who had formerly resided on the Pacific coast. The regiment was completed about the 20th of June, 1861, and under Col. Matheson took part in the battle of Bull Run and in most of the subsequent battles in Virginia. His remains were sent to California, and buried with the honors of war at his former residence in that State.

*Sept. 17.*—MANSFIELD, Maj.-Gen. J. K. F. (See MANSFIELD.)

*Sept. 17.*—MCNEIL, Col. HUGH WATSON, an officer in the Union service, and commander of the Pennsylvania "Bucktail" regiment, killed at the battle of Antietam, while leading his regiment in a charge. He was a native of Seneca county, N. Y., and was of Scotch family, his father being a Cameronian clergyman; was born in 1830; was educated at Yale College, studied law at Auburn, and commenced practice in New York in 1857, but left his profession on account of ill health, removed to Pennsylvania, and engaged in banking. At the commencement of the war he joined the Bucktail regiment as a private, but was soon chosen first lieutenant, and rose by successive promotions to the command.

*Sept. 17.*—HINKS, Col. EDWARD W., an officer in the Union service, commanding the 19th regiment Massachusetts volunteers, killed at the battle of Antietam. He was born in Lynn, Mass., and had been prominent as a militia officer before the war, and in the spring and summer of 1861 commanded the 8th regiment of Massachusetts infantry, the regiment which so distinguished itself on the route from Annapolis to Washington by repairing the locomotives and rebuilding the railroad damaged by the se-

cessionists. After the expiration of their term of service he returned to Massachusetts, raised the 19th regiment, and returned with it to the field. At the battle of Ball's Bluff he protected the retreat of the Federal troops, and in the battles on the peninsula and this side of the Rappidan his regiment was known as one of the "Massachusetts fighting regiments." At Antietam he was leading his troops in one of those desperate charges which won the day, when he received his death wound.

*Sept. 17.*—PARISEN, Lieut.-Col. PHILIP J., an officer in the Union service, at the time of his death in command of the 57th regiment New York State volunteers, killed at the battle of Antietam. He was a native of New York city and entered the service Dec. 21, 1861, as major of the 57th, and early in 1862 was promoted to a lieutenant-colonelcy. He took part in most of the battles on the peninsula and in those of August in the vicinity of Washington. He was shot through the body and instantly killed while leading his regiment at Antietam.

*Sept. 17.*—PEROIVAL, JOHN, a captain in the U. S. navy, died at Roxbury, Mass. He was a native of Massachusetts, and had been nearly 50 years in the navy. Under the act of February 28, 1855, he had been placed on the reserve list, and was absent from duty on leave at the time of his death.

*Sept. 17.*—CHILDS, Col. J. H., an officer in the Union service, colonel of the 4th Pennsylvania cavalry, and at the time of his death acting brigadier-general, killed at the battle of Antietam. He was a citizen of Pittsburg, Pa., and entered the service in July, 1861. He had distinguished himself in several battles for courage, coolness, and skill, and at Antietam was in command of a brigade of cavalry.

*Sept. 17.*—COLEMAN, Col. AUGUSTUS H., an officer of the Union service, commanding the 11th Ohio regiment, killed at the battle of Antietam. He entered the service as major of the 11th regiment, at the beginning of the war, and after its reorganization, on the resignation of Lieut.-Col. Frizell, in Jan. 1862, was promoted to the rank of lieutenant-colonel and soon afterward of colonel. His regiment had done service in western Virginia as a part of Cox's brigade, and Col. Coleman had a high reputation for bravery and daring.

*Sept. 17.*—CROASDALE, Col. SAMUEL, an officer of the Union service, commanding the 128th Pennsylvania regiment, killed at the battle of Antietam. He was a citizen of Doylestown, Pa., and had a large practice in that town as a lawyer. Immediately after the President's proclamation of April 15, 1861, he volunteered as a private in Capt. Davis's company of three months' men. On their discharge he resumed the practice of his profession, but on the governor's call for nine months' men, in the summer of 1862, he opened a recruiting office and raised a full company of the citizens of Doylestown and vicinity in a few days. The 128th regiment, composed almost entirely of citizens of

Berks, Lehigh, and Bucks counties, was organized soon after, and he was appointed its colonel. After a few weeks' service in camps of instruction near Washington, the emergencies of the invasion of Maryland required the services of Col. Crossdale's regiment in the field, and it marched with the grand army from Washington. At Antietam, though a new regiment, it was assigned an important position, and Col. Crossdale was leading it forward through a tempest of shot and shell when a musket ball passing through his brain killed him instantly.

*Sept. 18.*—KINGSBURY, COL. HENRY W., an officer of the U. S. army, commanding, at the time of his death, the 11th regiment Connecticut volunteers, died of wounds received the previous day at the battle of Antietam. He was a son of the late Major Julius J. B. Kingsbury, and was born in Connecticut in 1837. He entered West Point in 1856 and graduated in 1861, second in his class. Soon after his graduation he was assigned to the duty of drilling the volunteers at Washington, and after a short time put in command of a battery with the rank of captain. His thorough military knowledge and skill as an officer recommended him to the authorities of his native State, and he was offered the command of the 11th regiment. He acquitted himself nobly in his new position, and was regarded as an officer of great promise. In the battle of Antietam he was four times seriously wounded.

*Sept. 18.*—CURTIS, HARVEY, D. D., a Presbyterian clergyman, and at the time of his death president of Knox College, died at Galesburg, Illinois. He was a native of Adams, Jefferson county, New York, and was born in 1806. He graduated at Middlebury College, Vermont, in 1831, with the highest honors of his class, studied theology for the next three years at Princeton, N. J., and in 1835 was ordained pastor of the Congregational church in Brandon, Vermont. In 1841 he accepted an appointment from the American Home Missionary Society as their agent for Ohio and Indiana, and in 1848 received and accepted a call to the pastorate of the 2d Presbyterian church in Madison, Ind. After seven years of pastoral labor there he removed to Chicago, Illinois, to take the pastorate of the 1st Presbyterian church in that city. On the resignation of Rev. Dr. Blanchard he was elected president of Knox College, at Galesburg, in 1858.

*Sept. 19.* LITTLE, GEN. HENRY, an officer in the Confederate service, killed at the battle of Inka. He was a native of Mississippi, born about 1818, graduated at West Point in 1839, appointed 2d lieutenant in the 5th infantry, and distinguished himself at Monterey and Cerro Gordo. He had been promoted in 1858 to a captaincy in the 7th infantry, and at the commencement of the war was in command of the post of Albuquerque in New Mexico. He resigned, and was appointed a brigadier-general in the Confederate service, in the army of the Southwest.

*Sept. 19.*—DWIGHT, LIEUT.-COL. WILDER, an officer of the Union service, lieutenant-colonel, at the time of his death, of the 2d Massachusetts volunteers, died in the hospital at Boonsboro', Md., of wounds received in the battle of Antietam. He was a son of William Dwight, of Boston, and was born about 1832, and graduated at Harvard University in 1853. He joined the 2d regiment at its formation, and had won the reputation of a brave and skilful officer. In the retreat of Gen. Banks down the Shenandoah Valley in May, 1862, he was distinguished for his daring and the solicitude which he manifested for the safety of his men; and was taken prisoner during this retreat. At Antietam he was twice wounded. Three of his brothers are in the army.

*Sept. 29.*—TABER, ISAAC CONGDON, a prominent merchant of New Bedford, Mass., and at the time of his death mayor of that city, died at his residence in New Bedford. He was elected mayor in 1859, and continued in office by successive re-elections till his death.

*Sept. 29.*—NELSON, MAJOR-GEN. WILLIAM. (See NELSON, W.)

*Sept. 29.*—RODMAN, GEN. ISAAC PEACE, a brigadier-general in the Union service, died near Hagerstown, Md., of wounds received in the battle of Antietam. He was a native of South Kingston, R. I., born Aug. 28, 1822. He received a good early education, and engaged while yet a youth in the woollen manufacture, and had attained a high reputation for the character of the goods manufactured by his firm, which were sold in all parts of the country. At the commencement of the war he was a member of the State Senate; but at once resigned his seat, recruited a company for the 2d Rhode Island regiment (Col. Slocum's), and went to the war as its captain. His company were the first to fire upon the enemy at the battle of Bull Run, and fought bravely throughout that battle. He was appointed lieutenant-colonel of the 4th Rhode Island regiment at its organization, and soon after promoted to the colonelcy of that regiment, which was detailed to the Burnside expedition. At Roanoke Island Colonel Rodman took an active part, and at Newbern his regiment made the brilliant charge which won the day. His regiment also participated in the investment and reduction of Fort Macon, but before that was accomplished, Col. Rodman had received his commission as brigadier-general. An attack of typhoid fever induced by overexertion and exposure rendered it necessary for him to come home on sick leave, and he only recovered in time to join Gen. Burnside at Fredericksburg. Here he found himself, though only a brigadier-general, in command of Gen. Parke's division. In the month of battles which followed, Gen. Rodman did his full share, quietly and unostentatiously. At South Mountain and Antietam he displayed military genius of a high order, and in the terrible conflict by which the stone bridge was carried and held, he was stricken down.

*Sept. 29.*—**HALL, J. PRESCOTT**, a prominent member of the New York bar, died at Newport, R. I. He was born in 1795, had early attained eminence as a lawyer, and during the administrations of Presidents Tyler and Fillmore was district attorney for the southern district of New York.

*Sept. 29.*—**PRENTICE, WILLIAM C.**, at Augusta, Ky., from wounds received in the conflict at that place on Sept. 27th. He was the eldest son of Geo. D. Prentice, for many years editor of the "Louisville Journal," and a young man of remarkable powers. An intense Southern sympathizer, in spite of the arguments, remonstrances, and entreaties of parents and friends, made him join the Confederate ranks, and after a brief service of five weeks, he was fatally wounded. On his departure to join the Confederate force in Kentucky, his mother is said to have followed him four or five miles, with the hope of persuading him to return, but he declined her entreaties, saying: "Mother, I implore you not to ask me to stay. Honor calls me. I have talked long enough. I must now do something else, and show myself in my true colors."

*Sept. 30.*—**HALLETT, BENJAMIN F.**, a prominent democratic politician and lawyer of Massachusetts, died in Boston. He was born at Barnstable, Mass., in 1798, graduated at Brown University in 1816, studied law, and was admitted to the bar in Boston, but not coming speedily into an extensive practice, turned his attention to editorship, at first in Providence, but after a short time in Boston, where, upon the organization of the anti-masonic party, he became editor-in-chief of the "Boston Advocate," which was started to maintain the principles of that party. In 1827 he assumed the editorship of the "Boston Daily Advertiser," and in that paper advocated, with great zeal and earnestness, anti-masonry, temperance, and the views of the emancipationists. His uncompromising avowal of his sentiments made him many and bitter enemies, and his paper became so unpopular that in 1831 he left the editorial chair. Failing to secure from Mr. Clay pledges by which he could receive the votes of anti-masons, he became and remained to his last day one of the bitterest opponents of that statesman. After the decay of the anti-masonic party, Mr. Hallett joined the democratic party. Though seldom in office (he was U. S. district attorney for Massachusetts under President Pierce), he exerted a powerful influence on the party, was a delegate at most of its national conventions, and the chairman for many years of its national committee. He aided the nomination of Franklin Pierce and James Buchanan, and was the author of the Cincinnati platform of 1856. In private life, he was one of the most amiable, genial, and agreeable of men, and a pattern husband and father.

*Sept. 30.*—**MILLER, JACOB W.**, ex-U. S. Senator from New Jersey, died at Morristown, New Jersey. He was born in German Valley, Morris

county, in November, 1800. After enjoying the advantages of a good academical education, he studied law with his brother, W. W. Miller, and was admitted to the Morris county bar. He attained in a few years a large practice, particularly in the higher courts, and acquired distinction as a counsellor. In 1838 he was chosen, by the whigs, State Senator, and in 1840 was elected United States Senator, where he was regarded as an able and clear-headed legislator. In 1846 he was reelected to the Senate and served until March, 1853, with entire satisfaction to his constituents. He opposed the compromise measures of 1850. In 1855 he avowed himself a republican, and lent his influence to the promotion of the measures of that party till his death. In private life few men have been more universally esteemed.

*Sept. —.*—**CASEY, HON. ZADOC**, died at Caseyville, Ill., aged about sixty-six years. He was lieutenant-governor of Illinois during Gov. Reynolds' term as governor, had been a member of Congress for two terms, and was a member of the Constitutional Convention of 1862.

*Oct. 1.*—**FISHER, ELWOOD**, an editor and statistical writer, died at Atlanta, Ga. He was born Oct. 1, 1808, and was of a family belonging to the Society of Friends, but has long been known as an ardent and extreme defender of slavery, and for years an open advocate of the secession of the Southern States, in favor of which he had written much. In 1850 he established in Washington a paper called the "Southern Press," having secession as its avowed object. About the commencement of the war, he went to Nashville, Tenn., and did all in his power to promote the plans and measures of the secessionists of that State. When Nashville was occupied by Federal troops he retired to Georgia.

*Oct. 4.*—**SMITH, COL. JOSEPH L. KIRBY**, of the 43d Ohio regiment, was killed at the battle of Corinth. He was born in 1836, was appointed a cadet of the Military Academy from New York, and graduated with the highest honors of his class in 1857, was at once appointed lieutenant of topographical engineers, accompanied the Utah expedition, was aide-de-camp to Gen. Patterson in 1860, and after his discharge appointed colonel of the 43d Ohio regiment, with which he served with distinction at Island No. Ten, his engineering abilities being brought almost constantly into requisition, and at the battle of Corinth, where he fell, had greatly distinguished himself for bravery and daring. He was a nephew of the Confederate general Edward Kirby Smith.

*Oct. 4.*—**ROGERS, COL. ———**, a Confederate officer, killed at the battle of Corinth. He was from Texas, and was at that battle in command of a brigade. When, on the morning of the 4th, the Confederate troops, which had expected to capture Corinth with but a slight struggle, found themselves repulsed by the terrible fire of the Union battery Robinett, and were compelled to fall back into the timber for

protection, Gen. Van Dorn called for volunteers to carry the battery by storm. Col. Rogers at once volunteered, and 2,000 men stepped from the ranks to accompany him. After addressing them a few words of encouragement he gave the order to march, and they moved forward at a quick step, in solid column eight deep, directly in face of the battery. Before they reached it nearly one half their number had fallen; but there was no faltering, the rear ranks stepped to the front and filled the gaps; they reached the outworks, and though twice driven back, succeeded the third time in planting their flag upon the parapet, when a volley from the guns of the inner works, at short range, killed a large number, among whom was the rashly brave Rogers. Gen. Rosecrans, in his general order after the battle, rendered the homage due from a chivalric foe to the brave man who led this attack, where death was so inevitable.

*Oct. 4.*—**HACKLEMAN, GEN. PLEASANT ADAM**, a brigadier-general in the Union army, killed at the battle of Corinth. He was a native of Franklin county, Indiana, born about 1817, was educated for the legal profession, and was prominent as a lawyer in the State. He became editor of the "Rushville Republican," about 1840, and continued as its editor till the commencement of the war. In 1841 he was a member of the Legislature of Indiana, and for several years afterward clerk of Rush county. In 1847 and 1858 he was a candidate for Congress, but was defeated on both occasions. In 1860 he was a member of the Republican National Convention at Chicago, and in 1861 of the Peace Conference at Washington. In 1861 he was appointed colonel of the 10th Indiana regiment, and served in Gen. Banks's corps in Virginia; his gallant and meritorious conduct there occasioned his promotion to the rank of brigadier-general, April 28, 1862, and in June, he was ordered to report to Gen. Grant, in the army of the Southwest. He took an active part in the battle of Iuka, and in the battle of Corinth was killed on the second day of the fight. He was a man of dignified and upright character and of superior abilities.

*Oct. 6.*—**COLMAN, WILLIAM DEAN**, a captain and assistant adjutant-general in the U. S. volunteers, and one of the staff of Brig.-Gen. Stanley, 2d division, army of the Mississippi, born in Salem, Mass., Sept. 15, 1827, the eldest son of Samuel Colman, publisher. On the breaking out of the war with Mexico he enlisted as a private in Walker's Mounted Rifles, and took an active part in the principal battles fought under Lieut.-Gen. Scott. When the first gun was fired by the Confederates at Fort Sumter he was assistant postmaster at New Orleans, but without stopping to count the cost, he abandoned all and hastened north to join the Union army. In the summer of 1861 he was appointed assistant quarter master, and in December a major in the Missouri State Militia, where he was actively occupied in the most

hazardous parts of that State till February, 1862, when he was ordered by Major-Gen. Halleck to the staff of Brig.-Gen. Stanley. On the 5th July, he accepted from the president a commission as captain, and assistant adjutant-general of U. S. volunteers. He was in all the battles and skirmishes, with Gen. Stanley, from New Madrid and Island No. Ten to the most memorable and sanguinary battle of Corinth on the 3d and 4th October, where he received a mortal wound, and died on the 6th after two days of severe suffering. He was buried with military honors, being much beloved and esteemed by Gens. Rosecrans, Stanley, and all on the staff, for his bravery, patriotism, and strict adherence to duty.

*Oct. 6.*—**SLAMM, LEVI D.**, a purser in the navy, died at Mamaroneck, Westchester county, N. Y., from the effects of a fall while going on board ship at Montevideo, in 1860. He was born in New York in 1812, and was for some years a leading democratic politician of the "hard money" school, and edited for a considerable time a democratic newspaper in the city. In 1846 he was appointed a purser in the navy, which office he held till his death.

*Oct. 8.*—**TERRILL, GEN. WILLIAM R.**, a brigadier-general of the Union army, killed at the battle of Perryville. He was a native of Virginia, born about 1832, and appointed from that State a cadet at the Military Academy, where he graduated in 1853, and was immediately appointed brevet second lieutenant of the 8d artillery, from which he was transferred to the 4th artillery in November following as second lieutenant. In 1855 he was appointed assistant professor of mathematics at West Point. In 1856 he was promoted to a first lieutenantcy, and in May, 1861, was appointed captain in the 5th artillery, and assigned to duty on the coast survey. He soon after raised a regiment of volunteers, was sent to Kentucky, where he commanded a battery in Gen. McCook's division, was transferred to the command of a brigade, and for his gallant and meritorious conduct at the battle of Shiloh, was appointed brigadier-general of volunteers, his commission bearing date Sept. 9, 1862. At Perryville, he was killed while urging forward his brigade against the enemy.

*Oct. 8.*—**JACKSON, GEN. JAMES S.**, a brigadier-general in the Union service, killed at the battle of Perryville. He was a native of Kentucky, born about 1822, and educated for the bar. He had been some years in the practice of his profession, when at the commencement of the Mexican war he raised a regiment of volunteers, and served during the war. During his service in Mexico he had a difficulty with Col. Thomas F. Marshall, which resulted in a duel. On his return to Kentucky he resumed his practice first at Greenupsburg, and afterward at Hopkinsville, Ky., and in 1860 was elected to Congress from the 2d congressional district of that State. In the autumn of 1861 he resigned his seat in Congress, and took

command of the 8d regiment Kentucky cavalry, was an active participant in most of the battles of the winter and spring of 1861, and on the 16th of July was commissioned a brigadier-general. In the battle of Perryville he commanded a division of McCook's corps, of the army of the Ohio.

*Oct. 9.*—WEBSTER, GEORGE, colonel of the 98th Ohio volunteer infantry, died of wounds received the preceding day in the battle of Perryville. He was born in Butler county, Ohio, in 1822. He volunteered in the Mexican war as a private soldier, but was promoted to be sergeant-major. After his return from Mexico he commenced the practice of law in Jefferson county, Ohio. In June, 1861, he volunteered as major of the 25th Ohio, and was promoted to a lieutenant-colonelcy in that regiment, and on the organization of the 98th regiment, in the summer of 1862, was appointed colonel. This regiment was ordered to join Gen. Buell's army, and at the battle of Perryville, Col. Webster was put in command of one of the brigades of Jackson's division of McCook's corps.

*Oct. 11.*—TALLMADGE, Capt. GREER, quartermaster-general at Fortress Monroe, died of disease of the liver, at his quarters in that fortress. He was born in Dutchess county, New York, in 1826. He was the son of Hon. N. P. Tallmadge, late U. S. Senator from New York. He graduated at West Point in 1848, and was appointed brevet-second lieutenant in the 1st artillery; early the following year he sailed with a detachment of United States troops for Fort Vancouver, Oregon Territory, where he was stationed for a year; returning in 1850 he was appointed aid to Gen. Wool, and after three years' service on his staff was ordered to Fort Niagara, and subsequently to Fort Ontario. In 1858 he was promoted to a first lieutenantcy in the 4th artillery, and 1857 accompanied the expedition to Utah, as an officer of Capt. (now General) Phelps's battery. In 1858 he was ordered to Fortress Monroe, and in May, 1861, promoted to the rank of captain in the quartermaster's department. The great labor of organizing the quartermaster's department for so large a force as was congregated in the military department of Fortress Monroe, and the added duties of assistant adjutant-general, which he discharged for a time, made his position one of great toil and responsibility, but they were admirably performed. The "contraband" idea put in practice by Gen. Butler, originated with him.

*Oct. 11.*—CHEESEMAN, JOHN C., M. D., an eminent physician and surgeon, died in New York city, aged 75.

*Oct. 13.*—COOPER, EDWARD S., M. D., an eminent surgeon, died in San Francisco, Cal. He was a native of Somerville county, Ohio, and was born in 1821. After receiving a very thorough medical education at Cincinnati and St. Louis, he commenced practice in Peoria, Ill., but in 1855 removed to San Francisco, where his eminent abilities and remarkable

skill as an operating surgeon, soon placed him at the head of the profession, and gained him a high reputation among his professional brethren in the Eastern States, and in Europe. He took an active part in the organization of the medical department of the University of the Pacific, and at the time of his death, was its professor of surgery and president of its faculty.

*Oct. 15.*—HUDSON, Captain WILLIAM L., U. S. navy, died of apoplexy in Brooklyn, N. Y. He was born in New York, May 11, 1794, entered the navy in 1816, and had worked his way up from a midshipman to a captaincy. He was second in command in Commodore Wilkes's exploring expedition, and was commander of the Peacock sloop of war when she was lost by her pilot's carelessness, on the rocks at the mouth of Columbia river. He was for several years commandant of the Brooklyn navy yard, in 1855 was promoted to a captaincy, and in 1857 was assigned to the command of the Niagara, on her first Atlantic cable expedition. This proving unsuccessful, the effort to lay the cable was repeated in the following year, and for his services to science on that occasion, Capt. Hudson was honored with an ovation by his fellow citizens of New York, and received from the governments of Great Britain and Russia several valuable gifts and other marks of distinction. On his return he was assigned to the command of the Charlestown navy yard. In August, 1862, he was put on the retired list, and appointed one of the board of lighthouse inspectors, which office he held at the time of his death.

*Oct. 16.*—ANDERSON, Gen. GEORGE B., an officer in the Confederate army, died in Raleigh, N. C. He was born in Wilmington, N. C., in 1827, entered West Point from that State in 1848, graduated in 1852, and was appointed brevet 2d lieutenant in the 2d dragoons, promoted to be 1st lieutenant in 1855, and in 1858 appointed adjutant of his regiment with the rank of captain. He resigned in April, 1861, entered the Confederate army, where he was soon appointed brigadier-general, and at the battle of Antietam received a wound in the foot, which eventually proved fatal.

*Oct. 17.*—JAMES, Gen. CHARLES T., an American inventor and ex-U. S. Senator, died at Sag Harbor, L. I., from wounds received by the explosion of a shell the previous day. He was born in West Greenwich, Rhode Island, in 1804, and having a remarkable aptitude for mechanical pursuits he early learned the trade of a carpenter, and at the age of 19 began to study the science of mechanics, with a view to master the business of the cotton manufacture, proceeding at the same time as a workman, step by step, through every department of the machine shops where the machinery for the cotton mills was manufactured. This accomplished, he removed to Providence, and became superintendent of Slater's steam cotton mills, and while in this position, was chosen major-general of the Rhode Island militia. In 1838, Brown University con-

ferred on him the honorary degree of master of arts. After a few years' residence in Providence he removed to Newburyport, Mass., where he erected the Bartlett and James Mills, and subsequently erected cotton mills in Salem, Mass., and in the States of New York, Pennsylvania, Indiana, and Tennessee, and returning in 1849 to Rhode Island, he erected the Atlantic Delaine mill at Olneyville. In 1851 he was elected to the U. S. Senate, and on his retirement from the Senate, he devoted his attention to the perfection of several inventions, among which was a rifled cannon and a new projectile, in the ultimate success of which he had the utmost confidence. He was thoroughly versed in the use and philosophy of firearms, and had long been regarded as one of the best marksmen in the State. It was by the premature explosion of one of his projectiles that he met with his untimely end.

*Oct. 20.*—HEWITT, Major IRA L., a paymaster in the United States army, died in the city of New York. He resided for some years in Illinois, but emigrated to Texas in 1840 and had there become one of the associate justices of the supreme court of the State. At the commencement of the war, his attachment to the Union being known, his life was in danger, but he succeeded in escaping from the State by stratagem, and joining the army served at Ship Island and New Orleans under Gen. Butler, and when Col. A. J. Hamilton came north, accompanied him and was assigned to duty in New York.

*Oct. 30.*—MITCHEL, Maj.-Gen. ORMSBY McKNIGHT. (See MITCHEL, O. M.)

*Nov. 5.*—POPE, Col. CURRAN, commander of the 15th Kentucky regiment, died at Danville, of wounds received at the battle of Perryville, on the 8th of October previous. He was a member of one of the most distinguished families of Kentucky, and was born in Louisville about 1818. He entered West Point as a cadet in 1829 and graduated in 1834, but soon after left the army to follow the profession of civil engineer. Early in the war a number of his relatives joined the Confederate army, but he adhered firmly to the cause of the Union, and abandoning his profession, raised the regiment which he commanded at the time of his death.

*Nov. 6.*—JAMESON, Gen. CHARLES DAVIS, died at Oldtown, Me., from camp fever, brought on by his exertions at the battle of Fair Oaks and the pestilential influence of the climate. He was born at Gorham, Me., Feb. 24, 1827; while yet very young, his parents removed to Oldtown, Me., where after receiving a limited academic education he at an early age embarked in the lumber business, and eventually became one of the largest manufacturers and shippers of lumber on the Penobscot. He had been an active adherent to the Douglas section of the democracy, and in 1860 was a Douglas delegate to the Charleston Convention, where he became convinced of the intentions of the Southern States to secede. At the commencement of the war,

he was one of the first, if not the first, of the prominent democrats of the State to offer his services to the Government, and was placed by Gen. Washburn in command of the first regiment which left that State for the beleaguered capital. In the battle of Bull Run he commanded this regiment (2d Maine) and distinguished himself by his bravery, and with his regiment protected the rear in its retreat to Centreville. For his conduct on that day he was appointed brigadier-general of volunteers, on the 3d of Sept. 1861. In the autumn of 1861 he was, without his knowledge or consent, nominated by the democrats of his own State for governor, and polled a heavy vote though defeated by the republican candidate. In the spring and early summer of 1862, he took an active part in the campaign on the peninsula, in Gen. Heintzelman's corps, and by his exertions there, both before and at the battle of Fair Oaks, contracted the fever which finally terminated his life. He ranked high as a disciplinarian and as a brave and competent commander.

*Nov. 7.*—PENDERGRAST, Commodore GARRETT, J., commandant of the navy yard at Philadelphia, died in that city, aged 62 years. He was a native of Kentucky, and entered the navy when only 11 years of age, and had been in the service since that time, passing through all the grades. In 1860 he was flag officer of the home squadron, and did service at the commencement of the war in the protection of the important harbor of Hampton Roads. In the autumn of 1861 he was assigned to the command of the navy yard at Philadelphia. He died of paralysis.

*Nov. 7.*—BERRIAN, Rev. WILLIAM, D. D., rector of Trinity church, New York, died in that city. He was a native of New York city, born in 1787, and baptized in Trinity parish. He was educated at Columbia College, ordained deacon in 1810, and in 1811 became assistant minister of Trinity parish, his continuous connection with which was only broken by a brief settlement at Belleville, N. J., and two journeys abroad, in a period of more than 50 years. Though not a brilliant man he was earnest, conscientious, and able, and the position which he occupied as rector of the oldest and wealthiest of the metropolitan churches, never made him haughty or vain. He was much beloved by the older citizens of New York.

*Nov. 9.*—COLLYER, THOMAS, one of the most eminent ship builders of New York city, died at his residence there.

*Nov. 10.*—LAVALLETTE, Rear Admiral ELIZ A. F., of the United States navy, died at Philadelphia, where he was waiting orders. He was a native of Virginia, and had been in the navy over 50 years, having entered it when a mere lad. The Navy Retiring Board, on the 1st of August, 1862, reported in favor of his promotion to the rank of rear admiral, and at the same time of placing him on the retired list for long and meritorious service. His last previous

appointment had been that of commandant at Sackett's Harbor, N. Y.

*Nov. 11.*—**MORGAN, MATTHEW, SEN.**, an eminent New York shipping merchant of the well known firm of Matthew Morgan and Sons, died in New York city.

*Nov. 11.*—**PORTER, HON. JAMES MADISON**, died in Easton, Penn. He was the son of Gen. Andrew Porter, of the Revolutionary War, and was born in 1792. He was educated for the bar, but served as a volunteer in the war of 1812. He was a member of the Constitutional Convention of Pennsylvania in 1838, and bore an important part in the revision of the State Constitution. In 1843 he was appointed Secretary of War in President Tyler's cabinet, and since his retirement from the cabinet had held many prominent positions. He was greatly honored and esteemed in Easton, where he had resided for more than 40 years. He was one of the founders of Lafayette College in that city, and for 25 years president of its board of trustees.

*Nov. 16.*—**PRESTON, HON. WILLIAM BALLARD**, a senator from Virginia in the Confederate Congress, died at his residence in Montgomery county, Va. He had been a member of the Congress of the United States, and was Secretary of the Navy under President Taylor.

*Nov. 22.*—**PATTERSON, Brig.-Gen. FRANCOIS E.**, killed himself by the accidental discharge of his pistol in his tent at Fairfax Court House during the night. He was a native of Philadelphia, born in 1827, and had entered the army from civil life as second lieutenant of the 1st artillery in June, 1847. In March, 1855, he was promoted to a captaincy in the 9th infantry, then first organized. In May, 1857, he resigned, and devoted himself to civil pursuits. On the raising of the 115th Pennsylvania volunteers, Gov. Curtin offered him the command of the regiment, which he accepted, and acquitted himself so ably in the field, that on the 11th of April, 1862, he was appointed brigadier-general, and in the subsequent battles on the peninsula rendered efficient service.

*Nov. 27.*—**HANCHETT, HON. LUTHER**, representative in the 37th Congress from the 2d district of Wisconsin, and representative elect in the 38th Congress from the 6th district, died at Madison, Wisconsin, of brain fever. He was, at the time he was taken ill, on his way to Washington to take his seat in Congress.

*Nov. 28.*—**IRVIN, Gen. JAMES**, storekeeper of the Philadelphia navy yard, died in Philadelphia, aged about 60 years. He was a native of Pennsylvania, and had formerly been a prominent merchant of Centre county. He represented his district in Congress from 1841 to 1845, and was at one time the whig candidate for governor. During the Fremont and Lincoln campaigns he took an active part, and in the latter contributed materially to the success of the party to which he was attached in the State. He was one of the founders of the Pennsylvania Agricultural College, and gave two hundred acres of land for a farm for it.

*Nov. —.*—**WILKINSON, HON. JOHN**, died in Syracuse, N. Y., aged 70 years. He was one of the founders of that city, and had been for many years a prominent man in the State of New York, both in railroad and political matters. He had been for some years a leading director of the New York Central railroad, and was at one time president of the Michigan Central railroad.

*Nov. —.*—**VILLIFIGURE, Gen. JOHN B.**, a brigadier-general of the Confederate army, died at Port Hudson, La., of pneumonia. He was born in South Carolina about 1834; it is said that his father was of French and his mother of Spanish extraction. He graduated at West Point in 1854; was appointed to a second lieutenantcy in the 2d dragoons, and was promoted to a first lieutenantcy in 1857, and assigned to service in the Southwest. In March, 1861, he resigned from the U. S. service, and at once accepted an appointment as colonel in the Confederate service. In Nov. 1861, he was wounded at the bombardment of Fort Pickens, and soon after was made a brigadier-general in the Confederate army. He was assigned to the command of Fort Wright, and retained it until the evacuation of that post; participated in the battle of Corinth in October, 1862, and was soon after assigned to the command of Mobile.

*Dec. 6.*—**JACKSON, CLAIBORNE F.**, late Governor of Missouri, died at Little Rock, Ark., of cancer in the stomach. He was born in Fleming county, Ky., April 4, 1807, and emigrated to Missouri in 1822. In the "Black Hawk" war he raised a volunteer company, and served as captain. He was for ten or twelve terms a member of one or the other House of the Missouri Legislature, and for one term Speaker of the House. In the Session of 1848 he drew up and carried through the Legislature the famous Jackson resolutions. He was one of the prime movers in the organization of the present banking system of Missouri, and for a number of years Bank Commissioner. In 1860 he was elected Governor. His own sympathy with secession, and his determination to draw the State into it soon became evident, and having fled from the State capitol on the approach of Gen. Lyon, in July, he was deposed by the State Convention, and Gov. Gamble appointed provisional governor in his place. He acted for a short time as a general in the Confederate army, but his disease, from which he had long suffered, becoming aggravated, he retired to Little Rock, where he died after some months of suffering.

*Dec. 7.*—**WOODBIDGE TIMOTHY**, widely known as "the blind minister," died at Spencertown, Columbia county, N. Y. He was born in Stockbridge, Mass., Nov. 24, 1784, and was a grandson of Jonathan Edwards, the noted theologian. While at Williams College his vision became impaired, and for most of his senior year he was entirely blind. After graduating he studied law, and in 1810 entered

Andover Theological Institution to prepare for the ministry. In 1818 he received a call from the Presbyterian church in Spencertown to become their pastor, which he accepted, and remained in that relation till 1851, when in consequence of ill health he asked for a dismissal, but continued to preach occasionally till his death. In 1846 he received from Williams College the degree of D. D. Notwithstanding his infirmity he was very active and cheerful, a hard student, and an interesting preacher. In his method of conducting religious worship there was nothing to indicate to a stranger his blindness; the hymns and portions of the Scripture, though really repeated, were apparently read, and neither his appearance or manner gave indication that he was devoid of sight. In the vigor of his logic, and the clearness of his descriptions, he strongly resembled his distinguished ancestor.

*Dec. 8.*—OSGOOD, SAMUEL, D. D., a Congregational clergyman, died in Springfield, Mass. He was a native of Fryeburgh, Me., and was born in February, 1774. He graduated at Dartmouth College in 1805, and settled as pastor of the First Congregational church in Springfield in 1809. He continued in this relation till his death, a period of more than 58 years, though since 1854 he had a colleague, and had retired from the more laborious duties of the pastorate. He was an able preacher, and had taken an active and leading part in most of the great reforms of the day. He published a number of sermons and addresses.

*Dec. 10.*—DICKERSON, HON. PHILEMON, Judge of the United States District Court for the District of New Jersey, died at his residence in Paterson, N. J. He was born in Morris county, N. J., in 1788. After completing his college course he studied law with his brother in Philadelphia, Hon. Mahlon Dickerson, and in 1815 settled in Paterson. In 1838 he was elected to Congress, and reelected in 1835, and again in 1839; in 1842 he was appointed judge of the U. S. district court, over which he presided with dignity and ability till his death.

*Dec. 12.*—FULLER, REV. ARTHUR B., a Unitarian clergyman, and chaplain of the 16th regiment Massachusetts volunteers, killed while crossing the Rappahannock with a portion of his regiment, who had volunteered to cross the river, and drive off the sharpshooters who were preventing the laying of the pontoon bridges. He was born in 1824 at Cambridgeport, Mass., and was the son of Hon. Timothy Fuller, an eminent lawyer and member of Congress from 1817 to 1825, and a brother of the celebrated Margaret Fuller, Countess D'Ossoli. In his childhood the family removed to Groton, Mass., and by an accident in his boyhood Arthur lost an eye. He was fitted for college by his sister, and entered Harvard university in 1839, graduating in 1843. After studying theology at the Cambridge Divinity School, Mr. Fuller went to Illinois as a teacher and missionary, and after some years' labor there returned—first to

Boston, and afterward to Watertown, Mass., where he was settled as pastor. He volunteered as a chaplain early in the war, and not only fulfilled his duties in that capacity unexceptionally, but by his earnest sympathy for the members of his regiment, and his careful solicitude for their health, their mental improvement, and their moral welfare, became the idol of his regiment, and exerted a powerful and salutary influence on other bodies of men in their vicinity. His patriotism and courage led him to risk all perils with his men, and when several companies of them volunteered as a forlorn hope in the mission of crossing the Rappahannock under a deadly fire, his prompt determination to go with them greatly stimulated their enthusiasm. He edited his sister's works, and had published several original volumes.

*Dec. 13.*—JACKSON, Brig.-Gen. CONRAD FEEGER, was killed at the battle of Fredericksburg, where he commanded the brigade formerly known as Gen. Ord's. He was a citizen of Pennsylvania, and previous to the war had been connected with the Pennsylvania Central and Reading railroads, where he was well and favorably known. Soon after the commencement of the war he was appointed colonel of the 9th regiment of the corps of Pennsylvania reserves, under the command of Gen. George A. McCall. The corps was ordered to Washington, July 22, 1861, and Col. Jackson's regiment entered that city on the 26th of that month with full numbers and completely equipped, and encamped near Seventh street. They were subsequently ordered to Tenallytown, and formed part of the 8d brigade then under command of Gen. E. O. C. Ord. The regiment was subsequently stationed on the heights south of the Potomac, and formed a part of the brigade which gained a victory at Dranesville. On the peninsula Col. Jackson distinguished himself at Mechanicsville and Gaines' Mills, and participated in the remaining contests of those memorable seven days. He also took an active part in the battles between the Rappahannock and Alexandria in the latter part of August; and having, on the departure of Gen. Ord to the West, been promoted to the command of the brigade, he led his troops into the action of South Mountain and Antietam. At Fredericksburg he was at the head of his troops, leading them on to a charge, when a rifle ball passed through his head, killing him instantly.

*Dec. 13.*—BAYARD, Brig.-Gen. GEORGE D., an officer of the United States army, was killed in the battle of Fredericksburg. He was a native of New York, born about 1836; he entered West Point as a cadet in 1852, and graduated in June, 1856, receiving immediately an appointment as 2d lieutenant of the 4th cavalry. On the 20th of Aug. 1861, he was promoted to a captaincy in his regiment, and was allowed leave of absence to take command of the 1st Pennsylvania volunteer cavalry attached to



Gen. McCall's reserve corps, and participated in the various battles of that fighting corps. On the 20th of Nov. 1861, he made a most brilliant and successful dash at the head of his regiment upon Dranesville. On the 10th of June, 1862, he was nominated as brigadier-general of volunteers commanding cavalry, his commission dating from the 28th of April. During the autumn he had done excellent service with his brigade, making frequent dashes into the enemy's lines, and driving them from the gaps of the Blue Ridge. At Fredericksburg he was attached to Gen. Franklin's corps. He was buried with military honors at Princeton, N. J.

*Dec. 13.*—CURTIS, Lieut.-Col. JOSEPH BRIDG-HAM, was killed at Fredericksburg while leading his regiment in a charge. He was born in New York in 1836, and was a son of the late George Curtis, president of the Continental Bank, and brother of the author, George Wm. Curtis. He had received an education as an engineer, and at the commencement of the war was a member of the engineer corps of the Central Park, and volunteered in the 7th regiment N. Y. S. M. as an engineer. Soon after that regiment was mustered out of the service he reentered the volunteer army as adjutant of the 4th Rhode Island regiment, one of the regiments attached to the Burnside expedition. He distinguished himself at the capture of Roanoke Island for coolness and daring, and was soon after appointed by Gen. Rodman assistant adjutant-general on his staff. The ability he displayed in this position led to his promotion soon after, at Gen. Burnside's request, to the lieutenant-colonelcy of the 4th Rhode Island, and with his regiment he joined the army of the Potomac on the peninsula, and was with it in that succession of terrible battles between the Rappahannock and Washington, and at South Mountain, and Antietam. In the last-named battle his regiment was so cut up that it was by command of the general withdrawn from the field, but the lieutenant-colonel did not go with it; seizing the musket and cartridge box of a dead soldier, he joined the ranks of a Pennsylvania regiment, and did duty as a private to the close of the battle. At Fredericksburg he was in command of the regiment, the colonel being disabled by a wound.

*Dec. 20.*—BAKER, WILLIAM L., American consul at Guaymas, on the western coast of Mexico, was murdered by a band of Apache Indians while visiting some silver mines near that city. He was a native of Rhode Island, but was appointed as consul from Maryland.

*Dec. 24.*—PEARCE, HON. JAMES A., U. S. Senator from Maryland, died at Charleston, Md. He was a native of Alexandria, Va., and was born Dec. 14, 1805. He graduated at Nassau Hall, Princeton, in 1822, and devoting himself to the legal profession, settled in Maryland, whence his family had emigrated. He early entered upon political life, being a member of the Legislature in 1831, and in 1835

was elected to Congress, where he served two terms, and in 1841 was reelected for a third time. In 1848 he was chosen U. S. Senator, and continued to represent Maryland in the Senate till his death. In the Senate he did much for the promotion of science, being an earnest advocate of the coast survey, and, as one of the regents of the Smithsonian Institution, was active in carrying out its great principle of the diffusion of knowledge among men. He was a member of the democratic party, and ardently devoted to the preservation of the Constitution and the Union.

*Dec. 30.*—BULKLEY, JUSTUS R., died at his residence in Rye, Westchester county, N. Y. He was born in 1813 at New Haven, graduated at Yale College, and entering the legal profession in New York city, soon attained a good practice. Being a large stockholder in the New York and New Haven Railroad Company, he was elected, when the overissues of stock in 1854 had nearly ruined the company, as its president. He was annually reelected to the presidency, which he held at the time of his death.

*Dec.*—OWSLEY, WILLIAM, ex-Governor of Kentucky, died at Danville, Ky., aged about 70 years. He was a man of great decision, firmness, and integrity of character. In 1824 he was Judge of the Supreme Court of Kentucky, and though young, maintained with great courage the principle of anti-repudiation, which Henry Clay had so eloquently advocated. The repudiation party, who were a majority in the Legislature, attempted to get rid of the inflexible judge by abolishing the supreme court and establishing a new one, but he held his position firmly, and the act of the Legislature was by the Supreme Court of the United States declared unconstitutional. When partisan zeal expired the people honored with their confidence the man who had dared to be just. In 1844 he was elected governor of the State by the whig party, and served for two terms.

OBITUARIES, FOREIGN.—*Jan. 10.*—WYATT, MATTHEW CORES, an eminent English sculptor, died at his residence in Paddington, London, aged 84 years. He was educated at Eton, where he was the contemporary of Lord Stuart de Rothsay. At the age of nineteen he was employed under the immediate patronage of His Majesty George III, in the design and execution of several works of art at Windsor Castle. The most remarkable of these was the cenotaph in St. George's Chapel, Windsor, to the memory of Her Royal Highness, the Princess Charlotte Augusta. He subsequently attained a high reputation by his equestrian statues, among which are those of the Duke of York, the Duke of Wellington, and the horse for the statue of King George III, at the east end of Pall Mall. One of his finest specimens of sculpture was his "Bashaw," the favorite Newfoundland dog of the late Earl of Dudley, to whom a poetical allusion was made by Lord Byron.

*Jan. 10.*—**BOERER, WILLIAM, F. R. S.**, an English botanist, died at his residence at Barrow-hill, Sussex, aged 80 years. In his extensive and accurate knowledge of the plants of the British Islands, he had probably no equal; and there was scarcely an important work upon British botany for the last fifty years, that had not acknowledged his assistance. In 1818 he commenced, in conjunction with the late Mr. Dawson Turner, a work on British lichens, but, owing to the death of the publisher and other adverse circumstances, it did not see the light until 1839. The "English botany" is also largely indebted to his pen for valuable contributions. He was a patron also of all the kindred sciences, and especially interested himself in the education of the poorer classes.

*Jan. 27.*—**HAWTREY, EDWARD CRAVEN, D.D.**, provost of Eton, died at the Lodge, Eton College. He was born at Burnham, Bucks, May 7, 1789; was educated at Eton, and admitted as a scholar of King's College, Cambridge, in 1807, and three years after became a fellow of that college. In 1814 he assumed the responsible and arduous duties of assistant master at Eton, and upon the resignation of Dr. Keate in 1834, was appointed head master. In 1853 upon the death of the Rev. Francis Hodgson, he was elected provost. As a member of the Roxburgh Club, he was well known in literary circles, and his intimate acquaintance with books enabled him to collect a library of great value. He was an accomplished scholar in the French, German, and Italian languages, and his translations were remarkable for their beauty and idiomatic propriety. His "*Il Trifoglio*" contains translations of poems, with a few original pieces in Greek, Italian, and German; the versions are from French and English into Greek,—from Latin, English, and German into Italian,—and from English into German, all executed with surprising accuracy. His administration at Eton gave evidence of superior wisdom and judgment, and restored to the college its character for classical preëminence, which for a time had seemed impaired.

*Jan. 27.*—**HORNE, Rev. THOMAS HARTWELL.** (See HORNE, Rev. T. H.)

*Jan. 28.*—**ATTREE, W. WAKEFORD**, an English barrister, died at Brighton, aged 55 years. He was educated at Eton, whence he proceeded to the University of Cambridge, where he graduated. In 1833 he was admitted to the bar by the Honorable Society of the Middle Temple, and at once joined the home circuit, and Sussex sessions. He was recorder of Hastings, Rye, and Seaford, and was known in legal circles as the editor of a report of the celebrated Braintree Church-rate case, and reporter of the "Law Journal" of cases decided by the House of Lords. He was a vice-president of the Brighton Royal Literary and Scientific Institution, and of the School of Art, a member of the Sussex Board of Examiners, and of the Council of Brighton College.

*Jan. 28.*—**SYMINGTON, W., D.D.**, professor

of theology in the seminary of the Reformed Presbyterian Church in Scotland, died at Glasgow in the 67th year of his age, and the 43d of his ministry. His works on the "Atonement and Intercession of Christ," and on the "Mediatorial Dominion of Christ," are the best known to the public. He was also the author of a volume of sermons.

*Jan. 30.*—**RUSSELL, JOHN**, an English barrister, died at Southbank, near Edinburgh, aged 82 years. As early as 1808 he was a member of the Society of Writers to the "signet." When the Jury Court was established, he was appointed one of the principal clerks, and continued to discharge the duties of that office until the Jury Court was merged in the Court of Sessions, when he became one of the Principal Clerks of Session. He was one of the managers of the great musical festivals held in Edinburgh more than forty years since upon the introduction of the music of Handel, Mozart, Beethoven, Rossini, and other great masters. He was one of the original founders of the Edinburgh Academy, for many years treasurer of the Royal Society, and likewise a director of the Union Bank, Edinburgh Life Assurance, and of many other associations.

*Jan. 31.*—**MACKENZIE, Rt. Rev. Bishop.** (See MACKENZIE.)

*February 4.*—**BIOT, JEAN BAPTISTE**, a celebrated French savant, died in Paris. He was born in that city, April 21, 1774. He was educated at the Lyceum of Louis le Grand, and in 1798 served as an artilleryman in the army of the North. In 1794 he entered the Polytechnic School at Paris, and after graduating, was appointed professor in the Central School of Beauvais, from whence, in 1800, he was called to the chair of Physical Science in the college of France. In 1803 he became a member of the Academy of Sciences, the year following became connected with the observatory, was soon after named a member of the bureau of longitudes, and was associated with Arago and Gay-Lussac in many important scientific researches. He accompanied the latter, in 1804, in his first balloon ascent, and from 1806 to 1809, was engaged in Spain with Arago in a series of triangulations to measure an arc of the meridian. On his return to Paris in 1809, he was elected professor of physical astronomy to the faculty of Sciences. In 1817 he visited the Orkneys to complete his labors on the arc of meridian. In 1840 the Royal Society of Great Britain awarded him the Rumford medal for his researches on the polarization of light. In 1841 he was elected a member of the French Academy of Inscriptions and Belles Letters, and in 1857 he was chosen a member of the Academie Française, in the place of Lacroix. The death of his son, E. O. Biot, an eminent oriental scholar, in 1850, saddened his later years. Biot was the author of numerous mathematical, astronomical and philosophical works, and of two biographies of great merit, Montaigne and Gay-Lussac. His most remarkable works are

"*Astronomie des Indiens et des Chinois*," and an essay on the polarization of light.

Feb. 6.—**ROSA, FRANCISCO MARTINEZ DE LA**, a Spanish statesman, died, aged 73 years. He was born in Granada, and educated at the university of that city. He took an active part in the struggles which marked the reign of Ferdinand VII, and on account of the liberalism evinced in a narrative written by himself of that revolution, was imprisoned for five years in the Spanish fortress of Peñon de Velez, on the Barbary coast. After the revolution of 1820 he was liberated, and subsequently was made secretary of foreign affairs, but in 1823, after the throne had been restored by French arms, he was exiled by Ferdinand VII, and went to Paris, where he remained eight years, during which time he published several works. In 1831 he was recalled, and in 1834 became the head of a cabinet, which lasted only a few months. He was twice ambassador to Rome, and also to Paris. In 1858 he became president of the Council of State, having been for some time previous its vice-president. He was the author of several tragedies, a poem on the "Art of Poetry" a history of the French Revolution entitled "Espiritu del Sigo," "Isabel de Solis," and the "Conspiracy of Venice."

Feb. 8.—**BUSK, HANS**, died at his residence, Great Cumberland Place, Hyde Park, aged 89 years. He was a man of high classical attainments and a true lover of literature. Having travelled much, he conversed fluently in most of the languages of Europe. In early life he resided some years in Russia, and was at one time a member of the Empress Catherine's celebrated Chevalier Guard. He had shared in the friendship of most of the political and literary celebrities of the early part of the century, among whom were Burke, Sir Philip Francis, Fox, Sheridan, Canning, Percival and Wilberforce, as well as of Byron, Moore and Scott. Since he attained his 80th year he commenced and completed a remarkable paraphrase of the Psalms entitled "Hebrew Lyrics."

Feb. 15.—**SHERMAN, Rev. JAMES**, a well-known English clergyman, died at his residence at Blackheath, aged 65 years. He was born in London, and at an early age apprenticed to an ivory turner, but his mind was directed to the Christian ministry, and in his sixteenth year he was admitted to the Countess of Huntingdon's college at Oshesunt. In 1836 he received a call to Surrey Chapel as the immediate successor of the Rev. Rowland Hill, and from his first appearance in the pulpit was very popular. In 1854, ill-health induced him to resign the pastoral office there, and take charge of a new chapel at Blackheath, where with a few interruptions he continued to minister until about a year previous to his death.

Feb. 15.—**SOMERSET, Lieut.-Gen. SIR HENRY**, K. O. B., K. H., died at Gibraltar. He was a son of Lord Charles Somerset, governor of the Cape of Good Hope, was born in 1794, entered the army in 1811, served in the campaigns of

1813 and 1814 under the Duke of Wellington in the Peninsula, and was present at the battles of Vittoria, Orthes, and Toulouse, besides minor contests. He was also in the campaign of the Netherlands in 1815. In 1817 he went to the Cape of Good Hope, where he was for many years in service under the successive governors. He took an active part in all the Kaffir wars, with his regiment, the Cape Mounted Rifles, and during the several commands ably distinguished himself. In 1834 he was made a knight of the Hanoverian Order, and subsequently a companion of the Order of the Bath. After the conclusion of the Kaffir war in 1853 he was made a knight commander of that order. The same year he left the Cape and was placed as major-general on the staff at Bombay, and in 1855 was made commander-in-chief. After serving the customary period in that capacity he returned home.

Feb. 19.—**TIERNEY, Rev. Canon MARK ALOYSIUS**, died at Arundel, aged 66 years. He was born at Brighton, educated under the Franciscan fathers in Warwickshire, and at the college of St. Edmund near Ware, and at the end of his philosophical and theological courses was ordained priest in 1818. His first appointment was assistant chaplain at Warwick street, whence he was removed to Lincoln's Inn Fields; but ill-health rendering it necessary that he should be transferred to a country mission, he was appointed to Slindon, in Sussex, where he remained for two or three years. In 1824 he became the chaplain of Bernard Edward, duke of Norfolk, and from that time resided at Arundel. His taste for historic research led him to devote the leisure of several years to the study of English history, and he freely gave to writers of eminence the benefit of his learning and research. Among his historic works is a new edition of Dodd's "Church History of England from the year 1500 to the year 1688." In 1833, he was elected a fellow of the Society of Antiquaries, London; and in 1841, a fellow of the Royal Society. On the formation of the Sussex Archæological Society in 1846, he became its local secretary, and showed his zeal for the Society's collections by supervising many papers, and contributing in 1849 to vol. iii, "Notices of recent Excavations in the Collegiate Church of Arundel;" and in 1860, to vol. xii, "An account of the Discovery of the Remains of John, 17th Earl of Arundel, in a Letter addressed to Wm. Durrant Cooper, Esq., F. S. A."

Feb. 22.—**PILLERSDORF, Baron**, died at Vienna, aged 75 years. In 1848 he was Minister of the Interior and afterward President of the Council. When the Austrian Parliament was closed, he lived in retirement, excluded from the court circle and took no share in public life until the last year, when his position was restored to him by the emperor, and he became the President of the Finance Committee of the Lower Chamber of the Diet.

Feb. 25.—**REED, Rev. ANDREW, D.D.**, died at

Cambridge-heath, Hackney, aged 75 years. He was born in London, and being the son of humble trades people, was apprenticed to a business, but having a taste for study, attracted the attention of the Rev. Matthew Wilks, through whose influence he obtained admission to a dissenting college at Hackney. In 1811, he became the minister of Wycliffe Chapel, Stepney, where he preached for fifty years. In 1834 the Independents sent a deputation to their brethren in the United States, and Mr. Reed and Mr. Matheson were associated in this tour, upon their return embodying the result of their observations in volumes which made a valuable addition to English knowledge of American institutions and society. In 1818 he founded the London Orphan Asylum; in 1827, the Infant Orphan Asylum; and in 1847, the Asylum for Fatherless Children at Croydon. While engaged in these works of mercy his attention was called to the neglect of any provision in England for idiots, and after travelling abroad and spending some time in investigation upon the subject, he returned home and founded the Royal Asylum for Idiots, and subsequently the Royal Hospital for Incurables. In all these objects of benevolence he was himself emphatically a worker, and while he freely gave his hundreds to the cause of charity, he made it a principle through life never to receive in any form a recompense for his services. By his will, he bequeathed a certain sum—the interest to be applied forever to “the purchase of toys for the Infant Orphans” at Wanstead; a larger sum for “Winter Scientific Lectures to the Orphan Children at Chapton,” £1,000 to the Asylum for Idiots, £1,000 to the Asylum for Fatherless Children at Reedham; and then bequeathed these institutions and the Royal Hospital, since founded, to the care of his beloved country.

*March 1.*—BARLOW, PETER, F. R. S., died at his residence at Old Charlton, aged 85 years. He was born in Norwich, and was educated in that city. In 1806 he was appointed one of the mathematical professors at the Royal Military Academy at Woolwich, which office he held until 1847. He was the author of numerous works, among which are his well-known treatises on the “Theory of Number,” the “Strength of Materials,” and his “Essay on Magnetism.” His discovery of the means of correcting the local attractions on the compasses of ships brought him into great notice. He received the Copley medal, was elected to the Council of the Royal Society, and the Board of Longitude conferred upon him the reward provided for useful nautical discoveries. The Emperor of Russia also presented him with a diploma of the Imperial Academy of Science at St. Petersburg; he was elected a corresponding member of the Institute of France and the Royal Society of Brussels. In 1836 he was appointed one of the Irish Railway Commissioners, and subsequently served on other royal commissions relating to railways in England. In

1847 he retired from the Royal Military Academy, when the Government awarded him full pay in consideration of his eminent services.

*March 3.*—GURNEY, Rev. JOHN HAMPDEN, rector of St. Mary's, Bryanstone Square, died at his residence in his 60th year. He was the eldest son of Sir John Gurney, one of the Barons of the Exchequer, was a member of Trinity College, Cambridge, where he graduated in 1824, his name appearing both in the Classical and Mathematical Tripos. He was for some time curate of Lutterworth in Leicestershire, and in 1848 was presented by the Crown with the rectory of St. Mary's in Marylebone. He was a most earnest and popular preacher, and among his published sermons are: “A Pastor's Warning,” suggested by the death of Sir Robert Peel, 1850; “The Lost Chief and a Mourning People,” a Sermon on the death of the Duke of Wellington, 1852; “The Grand Romish Fallacy, and Dangers and Duties of Protestants,” 1854; “Better Times and Worse,” 1856; and several series of sermons. His lectures were published under the titles of: “Historical Sketches, illustrating some important Epochs from A. D. 1400 to A. D. 1546;” “St. Louis and Henri IV;” and “God's Heroes and the World's Heroes,” 1858. Mr. Gurney was also the author of several psalm and hymn books, and of “Four letters to the Bishop of Exeter on Scripture Readers.”

*March 6.*—DOUGLAS, Sir JAMES DAWES, G. C. B., col. of the 42d Royal Highlanders, died at Clifton, aged 77 years. He entered the army in 1799, accompanied Gen. Crawford's expedition to South America on the quartermaster-general's staff, and was engaged in the attack on Buenos Ayres. He subsequently accompanied the expedition to Portugal under Sir Arthur Wellesley, and was present at several important battles. In 1809 he joined the peninsular army in command of a Portuguese regiment, and engaged in several battles, in one of which he was wounded. Being promoted to the command of the 7th Portuguese brigade, he served in a number of engagements and in that of Toulouse lost a leg. After the termination of the war, Sir James Douglas was employed on the staff of the army at home—first at the head of the quartermaster-general's department in Scotland, and afterward in the same post in Ireland. At the expiration of this command he was appointed governor of Guernsey, and received the honor of the Grand Cross of the Bath and the colonelcy of the 42d regiment.

*March 13.*—SEWELL, Gen. SIR WILLIAM, K. C. B., col. of the 79th regiment, died at Florence. He commenced his military career in 1806, and in the following year, having been appointed aide-de-camp to Gen. Beresford, accompanied him to the Peninsula, and joined the Duke of Wellington's army in Portugal in 1808. He was at the battles of Corunna, Talavera, and Busaco, the sieges of Ciudad Rodrigo, Badajos, and St. Sebastian, also the battles of Nivelle, Nive, Bayonne, Orthes, and Toulouse.

Having returned from the Peninsula, he proceeded to India, where he served for a period of twenty-eight years, and was appointed to a colonelsy of the 79th Foot in 1854, an appointment which he held until his death.

**March 17.**—HALÉVY, JACQUES, ELIE FROMENTAL, the favorite pupil of Cherubini, died at Nice, aged 62 years. He was born in Paris where, in his 12th year, he won the grand prize for harmony at the Conservatoire. After two years of instruction in this public school of music he was placed under the care of Cherubini, and made such proficiency that within the space of two years more he was intrusted by his master with the charge of his class while the latter visited London. He was sent to Rome by the French Academy, and during his residence there, wrote his first opera, *Pygmalion*. In 1827 he published his *Phidias*, the popularity of which had not decreased when it was followed by *The Artisan*. In 1835 he produced at the Académie de Musique the opera *La Juive*, which was immediately brought out in every capital in Europe. He composed several comic operas which met with great favor, among which are his *Guido et Genevra* and *Charles VI*. His other productions were: *Le Roi et le Bâtelier*; the *Val d'Andorre*, which ran continuously for 165 nights; *Guitarero*, *Les Mousquetaires de la Reine*, *La Fée aux Roses*, and *La Magicienne*. His last opera was "*Nos ou le Déluge*." In 1854 he was elected perpetual secretary of the Academy of Fine Arts.

**March 19.**—DON, SIR WM. HENRY, Bart., died at Hobart Town, Tasmania, aged 86 years. He was for a short time in the army, and was extra aide-de-camp to the lord lieutenant of Ireland in 1844. In 1845 he became lieutenant in the 5th dragoon guards, but retired the same year and took up the profession of an actor. His admiration of his art was intense, and his success as an actor appeared to afford him more unalloyed satisfaction than his relationship to earls and duchesses.

**March 23.**—NESSELRODE, Count. (See NESSELRODE.)

**March 24.**—WINDISCHGRATZ, ALFRED, Prince. (See WINDISCHGRATZ.)

**March 26.**—WHITE, Rev. JAMES, a clergyman of the Church of England, died at Bonchurch in the Isle of Wight. He was born in 1804, educated at Glasgow and Oxford, took orders in the Church of England, and was presented by Lord Brougham to a living in Suffolk, which he afterward gave up for another in Warwickshire. On ultimately succeeding to a considerable patrimony, he retired from the Church and devoted a large share of his time to literary pursuits. He was a contributor to Blackwood's Magazine. Among his later works are "*The Eighteen Christian Centuries*" and the "*History of France*."

**March 30.**—VANDEBURCH, M. EMILE, a popular dramatist, died at Reuil, aged 67 years. He commenced life as an officer in the army of La Vendée, and passed through several of

Napoleon's campaigns, but finding that he had some taste for dramatic composition, and no desire for military glory, he abandoned his profession and commenced writing for the Paris theatres. In the space of forty years he produced one hundred dramas, most of which were well received by the public. Among the most popular of his dramatic works were: *Les Camarades du Ministre*, *Le Camarade du Lit*, *Cotillon III*, *Jacques II*, and *Les Gamins de Paris*.

**April 2.**—ELMES, JAMES, an English author and architect, died at Greenwich, aged 79 years. He studied architecture under Mr. George Gibson, and gained the silver medal at the Royal Academy in 1804; his name, however, was best known as a professional author, and one of his most useful and popular works was that on *Dilapidations*, published in 1826. He was the editor of several periodical publications. Among his literary productions are several on Architecture and the Arts; "*Memoirs of the Life and Works of Sir Christopher Wren*," 1823; "*Horæ Vacivæ, a Thought-Book of the Wise Spirits of all Ages and all Countries, fit for all Men and all Hours*," 1851; and "*Thomas Clarkson, a Monograph: being a Contribution towards the History of the Abolition of the Slave Trade and Slavery*," 1854. Mr. Elmes was for many years surveyor to the port of London.

**April 8.**—ROSS, SIR JAMES CLARKE. (See ROSS, SIR J. C.)

**April 5.**—HOUSTON, Gen. SIR ROBERT, K.O.B., died at Torquay, aged 81 years. He entered the army of the East India Company at an early age, and proceeded to Bengal in 1795, where he continued to serve for twenty-five years. In 1854 he became a general, and was for ten years governor of the Military College at Adiscombe.

**April 8.**—CARROLL, SIR WM. FAREBROTHER, K.O.B., died at his residence, Greenwich Hospital, aged 77 years. He was born at Glencarrig, Wicklow, entered the navy in 1795 on board the "*Diamond*," then commanded by Sir Wm. Sidney Smith, under whom he served many years, and with whom he was taken prisoner in 1796. A year from the following August he was released and sent to the West Indies in the "*Syren*," in which he served at the capture of Surinam. He was present at the sieges of Gaeta and Scylla, and the storming of Capri, and in 1807 commanded the seamen and marines in the engagement in the Sea of Marmora. He had command of the Oadiz flotilla, and afterward coöperated in the defence of Tarifa. He was commander of the "*Volcano*" on the coast of Catalonia, and subsequently of the "*Cyrus*," on the coast of France. He had been sixty-seven times in action with the enemy upon sea and land, and had aided in the capture of nineteen sail of the line, eighteen frigates, and a vast number of smaller vessels.

**April 11.**—CHETHAM-STRODE, Admiral SIR EDWARD, K.O.B., K.C.H., died at his residence, Southill, Somersetshire, aged 87 years. He

entered the navy in 1786, and distinguished himself at Genoa, Toulon, Dantzic, and Algiers. He was captain superintendent of the Royal Naval Hospital at Hasler, and of the Royal Clarence Victualling-yard at Portsmouth from 1838 to 1841; was made K.O.B. in 1845.

*April 15.*—WYSE, Right Hon. Sir JOHN, K.C.B., H. M.'s Envoy Extraordinary, and Minister Plenipotentiary at the Court of Athens, died at Athens, aged 70 years. He received his education at Stonyhurst, and graduated with honor at Trinity College, Dublin; entered as a student at Lincoln's Inn, but was not called to the bar. He represented Tipperary in Parliament from 1830 to 1832, and Waterford city from 1835 to 1847, was subsequently lord of the treasury, and a privy councillor. He was known in the literary world as the author of "Walks in Rome," "Oriental Sketches," and other works. He married a daughter of Prince Lucien Bonaparte, from whom he was separated in 1828.

*April 15.*—HOPE, Rev. FREDERICK W. (*See HOPE, Rev. F. W.*)

*April 18.*—WEST, Sir JOHN, G.C.B., Admiral of the Fleet, died at his residence in Eaton Square, aged 88 years. He was born at Twickenham, entered the navy in 1788, as midshipman, in the "Pomona," and after seeing much service off the coast of Africa, West India, North America, the Mediterranean, and the Channel, was promoted in 1793 to a lieutenancy in the "Saturn." In the following year he was appointed to the "Royal George," in which ship he took part in Lord Howe's victory of June, 1794, and subsequently was in the action with the French fleets off the L'Orient. In 1795 he proceeded to the West Indies in command of the "Diligence," and returned to England in 1798, in charge of a convoy of 150 sail. In 1808 he was detached with His Majesty's ship "Excellent," and two bomb vessels, to the Bay of Rosas, coast of Catalonia, and occupied the castle of Trinity, which he held, with the assistance of the Spaniards, against repeated attacks of the French. In 1809 he was detached with three sail of the line to the Adriatic, to blockade the enemy's force lying under the batteries of Trieste, and while in this service captured a large convoy, proceeding from Venice to Trieste, protected by six heavy gunboats. On his return from the Adriatic he was sent with a squadron of six vessels for the defence of the Island of Sicily. He afterward conducted certain operations on the coasts of Sardinia and Tunis, and still later joined the channel fleet blockading the ports of Brest and Toulon. In 1830 he was commissioned vice-admiral, admiral in 1841, commander-in-chief in 1845; knight commander of the bath, 1840; grand cross, 1860, and admiral of the fleet in 1858.

*April 22.*—KINCAID, Capt. Sir JOHN, died at Hastings, aged 75 years. He was born at Dalbeath, near Falkirk, entered the army in 1809, and served throughout the Peninsular War with

the Rifle Brigade, from which he retired as captain in 1831. In 1845, upon the occurrence of a vacancy in one of the exonships of H.M.'s Royal Body Guard, the appointment was conferred upon him by the Duke of Wellington. In 1852, on becoming senior exon, he was knighted, according to the usual custom. In 1847 he was appointed Government Inspector of Prisons in Scotland, and in 1850 received the conjoined appointment of Inspector of Prisons and Factories. He was the author of "Adventures in the Rifle Brigade," and "Random Shots from a Rifleman."

*April 22.*—CAPUA, CHARLES FERDINAND, Prince of, died at Turin, aged 50 years. He was the son of Francis I, King of the Two Sicilies, and brother of Ferdinand II, who banished him from the court, being displeased at his marriage. Since the expulsion of his brother, Francis II, from Naples, he resided in Turin, being engaged in soliciting of King Victor Emanuel and the Italian Parliament, the restoration of his patrimony.

*April 27.*—LIVINGSTONE, MARY, wife of Dr. Livingstone, died in Central Africa. She was a daughter of Rev. Dr. Robert Moffat, and had accompanied her husband in many of his explorations. She had joined him on the Zambesi as he reached the coast from his adventurous journey up the Shire to the Lake Nyassa, but was soon attacked with fever, which, upon a relapse, proved fatal.

*April 30.*—DICKSON, Mrs. ELIZABETH, died at Tripoli, Barbary, in the 70th year of her age. She was a daughter of Archibald Dalzell, Esq., governor-general of Cape Coast Castle, and widow of John Dickson, Esq., surgeon R.N. When but sixteen years of age she made an eloquent appeal through the leading English journals, in behalf of the Christian captives who were suffering such inhuman treatment in Barbary, thereby arousing such a feeling in Europe as forced the subject upon the attention of the Government, and led to the final overthrow of that system of piracy which had so long been the disgrace of Europe. For her labors in this benevolent cause, she was made a member of the "Anti-piratical Society of Knights and Noble Ladies," receiving a gold medal, and a unanimous vote of thanks for her labors in that cause. The universal grief at her death, among all classes of people in Tripoli, is the best tribute to her benevolence and worth.

*May 2.*—WOLFF, Rev. JOSEPH, D.D. (*See WOLFF, Rev. JOSEPH.*)

*May 15.*—HAWES, Sir BENJAMIN, K.C.B., Under Secretary of State for the War Department, died at his house in Queen Square, Westminster, aged 65 years. He was born in London, educated in Dr. Carmalt's school at Putney, and began life as a soap manufacturer. His first public office was that of magistrate of Surrey, in which capacity he took an active part in the quarter sessions, and, by various public services, acquired so much influence that,

upon the passage of the Reform Act, he was elected to Parliament for the newly-created borough of Lambeth, and sat for that borough until 1847, when some dissatisfaction occurring among the electors of Lambeth, relative to one of their representatives holding office (he had been appointed, in 1846, Under Secretary of State for the Colonies), he was defeated, but was elected in 1848 for the Government borough of Kinsale. In 1851 he was transferred to the War Department; and at the beginning of the session of 1852 gave up his seat, and turned his attention entirely to the duties of his office. While in Parliament he was one of the most strenuous advocates of the repeal of the corn laws, and exerted himself successfully in behalf of the penny postage scheme. Through a motion of his, the Fine Arts' Commission was appointed, and many other important measures were carried. He was deeply interested in scientific subjects generally: the electric telegraph, the ventilation of public buildings, and Babbage's calculating machine, all received his advocacy. He was the author of several political pamphlets, and the adoption of the Armstrong gun was mainly due to his influence.

*May 16.*—**WAKEFIELD, EDWARD GIBBON, Esq.**, an English writer on political and social science, died at Wellington, New Zealand, aged 66 years. He was educated as a land-surveyor. Being left, while still quite young, a widower with a young family, he was induced to enter into a plot for elopement with a young heiress of fifteen whom he forcibly took to Gretna Green and married; but her relatives interfering, he was tried for abduction, and sentenced to three years' imprisonment. A special act of Parliament was subsequently passed, to make void any pretence of marriage. A book which he wrote upon his experiences in prison was the first step toward those reforms of the penal law which are due to him. From the criminal at home, he extended his inquiries to the convict in the Australian settlements, and he became so familiar with every detail of the subject, that reference is often made to his "Letters from Sidney," as having been written upon the spot. His book on "England and America," published in 1833, was written to illustrate the different sources of wealth which the two countries commanded—the one in its wide-spread lands, and the other in its abundant population and accumulated capital. The views promulgated in this work, together with previous efforts, led to the formation of an association to found the colony of South Australia. In 1837 he strongly urged the occupation of the islands of New Zealand by the English, and when the New Zealand Association was established, became a director, and a valuable colony was thus added to the British dominions. His attention was next turned to the causes of the many political troubles in Canada, and in the results which followed the investigations made by Lord Durham, in the establishment

of a more responsible government, may be traced the influence of his private secretary, Wakefield. Some years since he removed to the south of France for the benefit of his health, and subsequently to New Zealand, where he died.

*May 17.*—**PROTER, Rear Admiral, AUGUSTUS-LEOPOLD**, killed in action against the Taepings, in China, aged 53 years. He was born at St. Servan, France, and early showed a decided taste for the naval profession. At sixteen years of age he was admitted into the naval school of Angoulême, and after passing through the inferior ranks, at 38 years received the commission of captain in the royal navy. At this time the English and French Governments combined their efforts to put an end to the slave trade on the African coast, and Captain P. was employed in that service. After cruising three years on the coast of Africa he was appointed governor of Senegal, where he remained from 1850 to 1855, during which time he exerted himself to promote geographical explorations in that part of Africa. He served during the war with China, and for his services was promoted to the rank of rear-admiral. He subsequently joined the expedition against the Taepings, who threatened an attack upon Shanghai, and during the engagement at Nan-Jao lost his life.

*May 28.*—**BUCKLE, HENRY THOMAS.** (See BUCKLE.)

*May 29.*—**SAN MIGUEL, EVAERISTO, Duke de.** (See SAN MIGUEL.)

*May 31.*—**WILLSHIRE, Gen. Sir THOMAS, Bart., G.C.B.**, died at Hill-house, Windsor Forest, aged seventy-two years. He was born at Halifax, North America, and while still a child was enrolled on the list of officers of the 38th regiment, of which his father was paymaster. He received his early education at Lynn, in Norfolk, and subsequently attended a school at Kensington. In 1802 he accompanied the 38th regiment to the West Indies, where the corps remained for three years, and was then ordered to Buenos Ayres, to join the expedition of the Rio de la Plata. The attack on Buenos Ayres took place July, 1807, and the 38th, of which he was now captain, bore a conspicuous part upon that occasion. In 1808 he served with his regiment in the Peninsula. In 1812 he returned to Spain, where he served till the end of the war. In 1818 he led his regiment to the wilds of South Africa, where, during four years, he held a responsible command on the frontiers of Kaffir-land, opening roads through the jungle, and constructing bridges over the rivers; he likewise built a fort, which is called, in his honor, Fort Willshire. He held Grahamstown against a desperate attack by ten thousand Kaffirs; repulsing them with great slaughter, and following them into their own country, would listen to no proposals of peace until the abandonment by the Kaffirs of the territory between the Keiskamma and Great Fish rivers. In 1822 he proceeded to Bengal, and being pro-

noted, was removed to the Madras Presidency, and served against the Mahrattas. In 1839 he was placed in command of the Bombay column of the army of the Indus, in which he served during the whole Affghan campaign. He commanded the force that captured the fortress of Khelat, in 1839, and for this brilliant exploit was made a baronet, and received the thanks of both Houses of Parliament. In 1840 he was obliged to return to England for the recovery of his health, after which he accepted the command of Chatham, which he held five years, and resigned on attaining the rank of major-general.

*June 17.*—MONTANELLI GIUSEPPE, an Italian statesman, scholar and reformer, died at Florence, Italy. He was born in 1818, at Zucechio, in Tuscany, and at an early age gave evidence of the possession of rare talents. While yet a boy he attained a very high reputation as an organist and musical composer. Turning his attention to the study of law, he obtained, at the age of eighteen, the degree of Doctor of Laws. He also occupied a portion of his time with literature, engaged with great zeal in philosophical studies, and, at the age of twenty-three, published a volume of poems of very remarkable merit. Entering upon the practice of his profession, he took the first rank as a pleader, and, at the age of twenty-seven, was chosen professor of Tuscan and commercial law in the University of Pisa. While occupying this chair he published numerous works on subjects connected with the study of law, one of which, "A philosophical Introduction to the Study of Commercial Law," is still considered the ablest treatise published on the subject. He was, from early youth, deeply imbued with liberal and republican sentiments, and in 1844 organized a secret association called the "Italian Brothers," whose fundamental principle was "the elevation and moral improvement of the individual as the necessary basis of the regeneration of the nation." In 1847 he established a journal called "Italy," in which he openly propagated the liberal views he had previously disseminated by his circulars among the "Brotherhood." In the revolution of 1848 he volunteered, and led the University Legion, composed of his brother professors and students, to join the Tuscan contingent, and on the 29th of May encountered Radetzki and the Austrians on the bloody field of Mantua. In this battle he was severely wounded, and left upon the field for dead. The intelligence of his supposed death caused great grief throughout Italy, and in all the principal cities of the peninsula imposing funeral services were held in honor of the "martyr of the national cause." He had been, however, taken from the field by the Austrians, and sent to the Lower Tyrol as a prisoner, where he recovered from his wounds, and, in August, was set free by the armistice, and returned to Tuscany, where he was received with enthusiasm. The Grand Duke, who had been compelled to grant a con-

stitutional government to the people, appointed Montanelli governor of Livourna, then in a state of insurrection. He quieted the people, and the Grand Duke next called him to form a ministry, and made him Minister of Foreign Affairs and President of Council. The reactionary tendencies of the Grand Duke were so evident, however, that the people were with difficulty restrained from insurrection, and in January, 1849, he fled from his capital. The people at once, and by acclamation, nominated a triumvirate, composed of Montanelli, Mazzini, and Guerrazzi. They at first governed in the name of the Grand Duke, but, as he protested against this, they determined to proclaim a republic, and a constituent assembly was organized, and the Florentine republic was preparing to unite with the Roman republic when the battle of Novara changed the face of affairs. Guerrazzi was proclaimed dictator, and Montanelli hastened to France to raise a legion of troops and to secure the aid of Louis Napoleon, but on his arrival found him determined to interfere on behalf of the reactionary movement. The Grand Duke was restored, and Montanelli remained an exile in Paris, and relieved the tedium of his banishment by writing tragedies for Madame Ristori, and, after a time, his "Recollections," which met with a large sale, and were translated into several languages. After the new revolution in Italy, Montanelli lost caste with his Italian friends and admirers by his strenuous advocacy of a confederation of States rather than a United Kingdom of Italy. His views on this subject seem to have been the result of a conviction that, under the complications which existed, this was the only future possible for Italy, and not, as was charged by some, the effect of imperial influence.

*June 17.*—CANNING, Rt. Hon. CHARLES JOHN. (See CANNING).

*June 27.*—BRUCE, Hon. ROBERT, Maj.-Gen., governor of the Prince of Wales, died at St. James's Palace, aged forty-nine years. He was the second son of Thomas, seventh earl of Elgin; entered the guards at the age of seventeen; was military secretary to his brother, Lord Elgin, in Jamaica, from 1841 to 1847, and again, in Canada, from 1847 to 1854, when he returned to England, and was for a short time surveyor general of the ordnance. In 1858 he accepted the appointment of governor to the Prince of Wales, and in that capacity attended His Royal Highness upon his tour to Canada and the United States in 1860, and during his residence in the two universities from 1859 to 1861. On his return from a tour with the prince to the East he contracted a fever which terminated fatally. His public and private life alike evinced his thorough qualification for the important and responsible trust he held.

*June 29.*—LINDSAY, JAMES B., an eminent linguist, died at Dundee, aged sixty-two years. He was a native of Carmylie, and studied at the University of St. Andrews for the ministry,



but was never ordained. He was passionately fond of scientific pursuits, and there was hardly a branch of learning that he was not capable of teaching; he was a frequent contributor to the local journals on scientific subjects, and published several learned works, among which was the *Lord's Prayer and the Creed in 50 different languages*; he also invented a chronostrolabe, which attracted the attention of the most eminent astronomers. For many years he labored in the prisons, instructing the inmates. He was a member of the British Association, and, his learning having attracted the attention of Her Majesty, he was offered a pension of £100 yearly, and subsequently gave up his appointment as teacher in the prisons, devoting himself entirely to literary and scientific pursuits. He was a member of the Free Church until 1861, when his views upon the subject of baptism underwent a change, and he joined the Baptist Congregation at Meadowside, publishing soon after an able treatise on baptism in explanation of his views. His library embraced all periods of history, in all languages. For many years he had been specially interested in the possibility of electrical communication through water without wires, and in the preparation of a dictionary in fifty languages, which, at the time of his death, was nearly completed.

July 5.—PASQUIER, Duke. (See PASQUIER.)

July 18.—BERESFORD, Lord J. G. (See BERESFORD.)

July 19.—BECKWITH, Major-General JOHN CHARLES. (See BECKWITH.)

July 22.—BLIGHT, Rear Admiral WILLIAM, died at Stonehouse, aged 77 years. He entered the navy in 1793, and after a few months' service as acting-lieutenant of the *Prince George*, was transferred to the *Britannia*, in which he served at the battle of Trafalgar. He was next employed on the *Santa Anna*, and successively on the *Dreadnaught*, *Nereide*, *Powerful*, and the *Queen Charlotte*. In October, 1808, he assisted at the destruction of two powerful pirate vessels, in the Persian Gulf, having seven hundred men on board, and the recapture of the *H. E. I. O.'s* war cruiser, *Sylph*. In 1821 he was promoted to the rank of commander, and in 1828 was appointed to the *Britannia*. In 1830 he attained post-rank, accepted the retirement, 1850, and was advanced to the rank of rear-admiral on the retired list, Sept. 27, 1855.

July 30.—TRAILL, Dr. THOMAS STEWART, professor of Medical Jurisprudence in the University of Edinburgh, died at his residence, in Rutland Square, Edinburgh, aged 80 years. He was a native of Kirkwall, in which parish his father was a minister; studied at the University of Edinburgh; took his degree in 1801, and in 1832 was appointed to the chair which he held at his death. During his long incumbency he was enabled to deliver his lectures regularly till within a few days of his death. He fulfilled the duty of editor of the last edition of the "*Encyclopædia Britannica*."

Aug. 8.—McNAB, Sir ALLAN. (See McNAB.)

Aug. 10.—CORR, M. ERIN, member of the Royal Academy of Belgium, died at Paris, aged 59 years. He was born at Brussels, and was the son of an expatriated Irishman, who had taken a part in the rebellion of 1798. As an engraver he had obtained the highest European reputation. His principal works are: the "*Saviour*," from Leonardo da Vinci; "*Christ upon the Cross*," from Vandyke; the "*Queen of Holland*," from Scheffer; and "*King Leopold*," from Woffers. He had but just completed his magnificent engraving on copper-plate of Rubens' celebrated picture, "*The Descent from the Cross*," after ten years' severe labor, and had gone to Paris to superintend the first impressions, when he died.

Aug. 16.—NUGENT, Marshal, a distinguished officer in the Austrian service, died at Croatia, Austria, aged 85 years. He was a native of Ireland, but many members of his family had long been settled in Austria, and his father, Count Nugent, was a well-known diplomatist. He entered into the army quite young, and served in the wars between Austria and France almost from the beginning of the French Revolution. He was long employed in Italy, under Radetsky, also against the Hungarians in 1848-9, and closed his military career at Solferino, after upward of sixty years' service. He was highly honored by the successive sovereigns, and made magnate of Hungary, a Roman prince, knight of the Golden Fleece, Councillor of State, Austrian field marshal, &c.

Aug. 20.—RICARDO, JOHN LEWIS, M. P. for Stoke-upon-Trent, died in Lowndes Square, aged 50 years. He was born in 1812, and entered Parliament in 1841. He was one of the earliest advocates for free trade, and aided materially in carrying the repeal of the corn laws. In 1847 he moved for a committee upon Navigation Laws, and warmly supported the repeal of the restrictions upon shipping; was the author of a work on that subject, "*The History and Anatomy of the Navigation Laws*," and devoted much attention to the question of maritime rights in time of war. It was mainly due to his efforts that the electric telegraph was established on so firm and successful a footing in England. For upward of ten years he was chairman of the Electric Telegraph Company, and during that time worked with untiring zeal and energy in developing all its resources, and rendering it of greater benefit to the civilized world, receiving upon his retirement from the chair a valuable addition to his library of 1,000 volumes, as a testimony of the attachment and respect of the officers and employes of the company. He was also chairman of several other companies, and for many years a director of the London and Westminster Bank.

Aug. 25.—BERKLEY, JAMES JOHN, chief engineer of the Great Indian Peninsular Railway, died at Sydenham, aged 42 years. He was an intimate friend and associate of the late Robert

Stephenson, and through him was at an early age intrusted with the responsible office of chief resident engineer of the Churnet Valley and Trent Valley railways. Under the advice of Mr. Stephenson he was appointed to the responsible position he held at the time of his death; and in January, 1850, he commenced the important work of laying out and making nearly 1,300 miles of railway. He designed the two great inclines over the lofty mountains of western India, known as the Bhoze and Thall Ghauts, and by which an uninterrupted communication will shortly be opened from Bombay, and eventually from Calcutta and Madras. Without sacrificing efficiency and durability in the execution of his works, he was decidedly an economical engineer, making all interests subordinate to those of the shareholders, and it is not therefore surprising that his line—the Great Indian Peninsular—bids fair to be the most profitable line in India.

Aug. 27.—HOGG, THOMAS JEFFERSON. (See Hogg, T. J.)

Aug. 27.—WILLIAMS, REV. JOHN (AP ITHEL), died at Llanenddwyn, Merionethshire. He was born at Llangynhafel, Denbighshire, April 7, 1811, and graduated from Jesus College, Oxford, 1834, and had been in succession vicar of the parishes of Llanfawr in Denbighshire, Nerguis in Flintshire, and Llangmowddwy in Merionethshire, and a few months before his death was preferred to the Rectory of Llanenddwyn by the Bishop of Bangor. Mr. Williams was one of the most profound scholars in Wales, and was especially well versed in the language and literature of his native country, and labored most untiringly and successfully in elucidating the various branches of Celtic Archaeology. He was a voluminous author, and besides nine or ten archaeological works, some of them requiring protracted and extensive research, he had written in Welsh and English a number of religious books.

Sept. 1.—ORTON REGINALD, M. D., an eminent English surgeon, died at his residence, Ford North Farms, Sunderland, aged 62 years. In 1833 he received the diploma of the Royal College of Surgeons, in 1834 that of licentiate of Apothecaries, and in 1835 took up his residence in Sunderland, as partner with the late Mr. Fothergill, surgeon, succeeding to the practice of the latter on his death, which occurred soon after. He held the offices of surgeon to the Sunderland Eye Infirmary, and consulting surgeon to Seaham Infirmary. He possessed a philanthropic disposition, and did much toward elevating the social and moral condition of the working classes, taking an active part in the establishment of local sanitary reforms, and in the support of local literary and scientific institutions. He had also attained distinction as a medical writer: an essay of his in the "Lancet" on "The Effects of Arsenic in the Animal System, and the Utility of the Hydroxide of Iron as an Antidote," attracted much attention. He invented a new "ether inhaling

apparatus," and made some experiments in inducing spontaneous generation by means of electricity; his alleged discoveries on this subject gave rise to a protracted and somewhat heated controversy. He took also a lively interest in maritime affairs, and invented a new and valuable life boat and some ingeniously contrived self-acting life buoys. The latter part of his life was mostly devoted to scientific farming.

Sept. 6.—SUMNER, Rt. Rev. JOHN BIRD, Archbishop of Canterbury. (See SUMNER, J. B.)

Sept. 16.—CASTELLANE, Marshal Count, governor of Lyons, died in that city. He was born at Paris, March 21, 1788; entered the army in 1804, and in 1806 was a sub-lieutenant of dragoons in the Italian army. The following year he became lieutenant, and went to Spain with Count Lobau as his aide-de-camp. He afterward served in Germany, and distinguished himself in the Russian campaign. At the Restoration in 1815 he was for a while unemployed, but toward the end of that year was charged with the organization of the hussars of the Bas-Rhin. In 1831-32 his gallant conduct at the siege of Antwerp procured him the rank of lieutenant-general. In 1837 he was raised to the peerage after good service at Algeria. He was in command of the military division of Rouen when the Revolution of 1848 broke out, and his firmness saved his division entire. In 1852 he was appointed to the important post of governor of Lyons, which he held until his death. He was a rigid disciplinarian and very eccentric in his character.

Sept. 18.—ALVES, Maj.-Gen. JOHN, died at King street, St. James, aged 75 years. He was born at Elgin; studied law, but having a fondness for military life, obtained a commission in a Scottish militia regiment, from thence exchanging into the 74th regiment, in which he served in the Peninsular War, and afterward in almost every quarter of the world. In 1851 he was promoted to the rank of lieutenant-colonel and appointed to the chief command of the depot battalion at Preston, in the north of England, where he was actively engaged during the Russian war in training troops for that service. At the close of the Crimean war he acquired the rank major-general, retired on full pay, and was also appointed sergeant-at-arms to the Queen, which made it necessary for him to reside at London.

Sept. 19.—ELLESMERE, GEORGE G. F. EGERTON, Earl of, died at Balbirnie, Fifeshire, aged 39 years. He was born in London, and upon the death of his father, Francis, first earl of Ellesmere, in February, 1857, he succeeded to the earldom and extensive family estates in Lancashire and Surrey. From 1847 to his removal to the House of Peers in 1851, he had a seat in the House of Commons as one of the representatives for the northern division of Staffordshire. During the few years he was in the lower House of Parliament, he warmly supported Lord John Russell's administration, and was strongly opposed to the endowment of

the Roman Catholic clergy. In 1851 he resigned his seat on account of the failure of his health. In 1857 he was appointed lieutenant-col. commandant of the Duke of Lancaster's Own Yeomanry Militia. One of his latest acts was the gift of £1,000 for the relief of the prevailing distress in Lancashire and Cheshire, owing to the "cotton famine."

Sept. 22.—JOMARD, EDMÉ FRANÇOIS, surnamed *de l'Institut*, died at Paris, aged 85 years. He was one of the earliest pupils of the Polytechnic School, and was appointed a member of the scientific commission which accompanied Bonaparte to Egypt in 1798. Upon his return to France he was sent on a topographical mission to the Upper Palatinate, but returned to Paris in order to aid and superintend the preparation of the *DESCRIPTION DE L'ÉGYPTE*, upon which he was engaged nearly eighteen years. He was mainly instrumental in introducing into France the Lancasterian system of education, though he had to contend with much opposition. Having obtained the favor of Mehemet Ali, he induced the pasha to send a number of young Egyptians to study in Paris, forming thus what was called the *Institut des Égyptiens*, which was placed under his particular direction. For his services the successor of Mehemet Ali appointed him his scientific correspondent and granted him the honorary title of bey. He was the author of many works on geography, archæology, education, &c.

Sept. 22.—HAMEL, DR. JOSEPH, member of the Imperial Academy of Sciences, St. Petersburg, died at his residence in Duke street, St. James, aged 74 years. He was born in Sarepta on the Volga, in Russia. In 1807 he distinguished himself by the invention of an electrical machine, and in 1813, after having completed his studies, he was named by the Emperor Alexander member of the Academy of Medicine. Having made a tour through England, he was afterward appointed to accompany the Grand Duke Nicholas, during his visit to England in 1815, and in 1818 discharged the same duties toward the younger brother, the Grand Duke Michael. In 1820 he made the well-known ascent of Mont Blanc, where he lost several of his guides. In 1821 he returned to Russia and was attached to the suite of the governor-general of Moscow. In 1828 he was elected a member of the Imperial Academy. It was through his exertions that the Lancasterian system of education was introduced into Russia, and also that the first industrial exhibition took place at Moscow. He took a lively interest in the progress of the arts, and visited all the great exhibitions in France and England, and also that in New York in 1854. He was the author of a history of the steam engine and of the electric telegraph—both of which are very complete and full of interest in a scientific point of view.

Sept. 25.—THOMPSON PISHEY, an English author, died at Stoke Newington, aged 78 years. He was born at Boston, Lincolnshire, Eng. In

1820 he published his "Collections for a Topographical and Historical Account of Boston, and the Hundred of Skirbeck." He afterward emigrated to this country, where he resided for many years—obtaining the friendship and esteem of several of the most eminent literary men in the New England States and Washington. Upon his return to England he commenced the preparations for his complete History of Boston, which was published about six years since. He was also the author of several pamphlets, and was a frequent contributor to newspapers both in England and in this country. He was thoroughly conversant with almost every branch of science and art, but so modest in his estimate of his own acquirements that none but those who knew him well could form any idea of the extent of his research and knowledge.

Oct. 8.—DUNDAS, Admiral Sir JAMES W. DEANE, G. O. B., died at Weymouth, aged 76 years. He entered the navy in 1799, as first-class volunteer on board the "Kent." In Nov. 1802, he was present at a skirmish with the French 74 gunship "Duguay Trouin," also at the blockade of Rochefort; served successively on the "Monarch" and "Cambrian," and in 1806, was promoted as commander of the "Rosa-mond," employed in attendance on the British ambassador to the King of Sweden at the siege of Stralsund. He subsequently distinguished himself in the command of the "Stately," "Venerable" and "Pyramus," in the latter of which he captured two privateers. In 1815, he joined the "Tagus" in the Mediterranean, and afterward served under Rear-Admiral Sir William Parker on the Lisbon station. In Dec. 1852, he became vice-admiral and was appointed to the "Britannia" as commander-in-chief of the Mediterranean and Black Sea fleet. He was a whig in politics, and the first representative of the borough of Greenwich after the passing of the Reform Act.

Oct. 6.—SMITH, Capt. WILLIAM, R. N., died at Berwick-on-Tweed, aged 71 years. He entered the navy in 1806, and served on the "Shannon." In the memorable action between that ship and the "Chesapeake" he was stationed with five men in the maintop of the "Shannon" and at their head, ran along the main yard, which was braced, and boarded the foretop of the "Chesapeake." For this he obtained the rank of lieutenant. He distinguished himself again in the Burmese war in 1825-26, when serving in the "Bodicea." In 1826, he was appointed commander, and subsequently had command of the "Philomel" and "Syren," in the latter serving in the East Indies from 1841 to 1844.

Oct. 7.—WARD, FREDERICK TOWNSEND, Admiral Gen., was killed during an engagement near Ningpo between the Taepings and the European allied army. He was born in Salem, Mass., in Nov. 1831, and was educated at the Salem High School. During the Crimean war he was a lieutenant in the French service.

Oct. 8.—**WALKER, JAMES, Esq., O. E., F. R. S.**, died in Great George Street, Westminster, aged 80 years. He was for many years president of the Institution of Civil Engineers, and his name was brought into great distinction in connection with bridge building and marine and hydraulic engineering. In these latter departments of his profession, he was for a long period consulting engineer to the Board of Admiralty.

Oct. 10.—**THORP, CHARLES, D. D., F. R. S.**, Archdeacon of Durham, and formerly Warden of the University, died at Ryton Rectory, Durham, aged 79 years. He was born at Gateshead Rectory, Oct. 13, 1788; educated at the Cathedral School, and at Oxford, where he obtained a fellowship, and subsequently was appointed tutor of University College, then under the headship of Dr. Griffith. In 1807, he was presented with the rectorship of Ryton, where he spent several years of active service. He took a deep interest in the establishment of Sabbath Schools, and made house to house visitations throughout his large parish, the records of which visitations are still extant. In 1829, he was presented with a prebendal stall in the Cathedral of Durham. In 1831, he was offered the valuable living of Stanhope, which he declined, and not long afterward was promoted by Bishop Van Mildert to the archdeaconry of Durham. At this time he was elected one of the Lord Crewe Trustees, in which capacity he exerted himself to the utmost in carrying out the donor's intentions for the benefit of the Church at large, and his firmness and judgment led to the establishment of the Convocation of York on a firm and intelligible basis. All the improvements made in the village, where most of the property was situated, were effected mainly through his exertions. His love of the fine arts was proverbial, and his gallery of pictures surpassed any other in the north of England. He was a man of rare benevolence. He gave £400 per annum to endow the parish of Winlaton, and erected at his own expense a church at Greenside, to the memory of his parents; also as a thank-offering, the Jubilee School at Ryton. More recently, he fitted out at great expense a beautiful chapel on the Feroe Islands, inside of which is a tombstone in memory of Grace Darling. Divine service is conducted in the chapel on Sundays during the summer months, and is attended by the lighthouse keepers and their families. On the establishment of the University of Durham, he became its first Warden, and did much toward the support of the new institution. His resignation took place a short time previous to his death.

Oct. 15.—**KEISER, Dr.**, a distinguished military surgeon, died at Breslau, Germany, aged 83 years. He entered France after the battle of Waterloo, at the head of the medical staff of the German army, and the military hospital at Versailles was placed under his direction. On his return to Germany, he was appointed to the professor's chair at the University of Jena.

He was a large contributor to the German literary reviews, and was the author of some well received works. He represented the University of Jena in the Parliament of Weimar, and also at Frankfort.

Oct. 21.—**BRODIE, Sir BENJAMIN COLLINS.** (See BRODIE.)

Oct. 28.—**MOORE, Sir W. G., Lieut.-Gen., K.C.B.** died at Montrosehouse, Petersham, aged 66 years. He was a son of Francis Moore, Under Secretary of War, and educated at Harrow, entered the army at fifteen as a member of the 52nd regiment, and embarked at once for the Peninsula. He was present at the sieges of Ciudad Rodrigo, Badajos, and St. Sebastian, and at the battles of Salamanca, Vittoria, Nivelle and Nive. He was wounded at the siege of Bayonne, and was present at the battle of Waterloo. He was appointed col.-commandant in Jan. 1856, and the same year was made a K. O. B.

Nov. 5.—**JERVOIS, Gen. WILLIAM, K. H.**, died at his residence, Portland-place, Bath, aged 79 years. He had served in the army nearly sixty years, having received his first commission in 1804, as ensign in the 89th regiment, which he accompanied to Hanover the following year. In 1810, he accompanied the expedition to Malaga, and was slightly wounded in the attack on the fortress of Frangerola. In 1813 he was appointed to the staff of Sir Gordon Drummond, with whom he embarked for Canada, where he was present at nearly all the actions fought with the American army. He was appointed to the colonelcy of the 76th Foot in 1853, and was commissioned general in 1860.

Nov. 9.—**BIRD, Rev. CHARLES, SMITH, M. A., F. L. S.**, chancellor of Lincoln Cathedral, and late fellow of Trinity College, Cambridge, died at the Chancery, Lincoln, aged 67 years. He was born at Everton, near Liverpool; studied law, but at the age of twenty-two, resolved to qualify himself for the Church, and entered Trinity College in 1817. In 1828 he was ordained priest; in 1843, became vicar of Gainsborough, and in 1859, was appointed chancellor of Lincoln cathedral. He was a fellow of the Linnæan Society, and author of a "Plea for the Reformed Church," "Defence of the English Reformation," "Lenten Lectures on the Decalogue," "Romanism not Primitive," "Strictures on Archdeacon Wilberforce's Works on the Incarnation and Eucharist," also of several pamphlets on Convocation, Visitation Sermons, &c. During the visitations of the cholera, particularly that of 1849, he devoted himself entirely to the bodily and spiritual wants of his parishioners. He also procured the erection of two new churches, and the Girls' National School and the Literary Institute owe their origin mainly to his exertions.

Nov. 10.—**WEBB, JAMES**, an eminent agriculturist, died at his estate of Babraham, England, aged 66 years. He had done much for the improvement of the short-horn Durham cattle, but his extensive reputation (and few agricul-

tourists were better known in all quarters of the globe) rested on his improvement in the South-down breed of sheep. The Webb Southdown was indeed almost his creation, so many years of thoughtful and intelligent care had he bestowed in bringing all its best points to perfection. For thirty-four years he had held an annual sale of his improved stock, and these sales had latterly been attended by sheep-breeders from every portion of Great Britain, and from France, Germany, Spain, Sweden, Italy, Turkey, Russia, the United States, and Australia. His last sale, in June, 1862, realized about \$80,000.

Nov. 13.—UHLAND, LUDWIG. (See UHLAND.)

Nov. 14.—STEWART, Rev. ALEXANDER, LL.D., died at the manse of Douglas, Scotland, aged 81 years. He had been for many years one of the best writers of Scotland, and had published a large number of educational works. He was one of the principal contributors to the Edinburgh Encyclopædia, and, in many instances, works which subsequently obtained a high popularity, owed to him that polish of diction and symmetry of arrangement, without which they would have fallen dead from the press.

Nov. 19.—WODDERSPOON, JOHN, Esq., assistant editor of the "Norwich Mercury," died at Norwich, England. He was born at Bath, in 1806, and was first engaged in that city on the "Bath Chronicle," and subsequently for two years at Birmingham, upon the "Birmingham Journal." After removing to London, he was engaged upon the "Suffolk Chronicle," edited by Mr. King, with whom he remained ten years, during which time he published some of the works which have won for him considerable antiquarian and literary fame. The first work of any importance was "Sketches of the Suffolk Bar," which was succeeded by "The Historic Sites of Suffolk." In 1845 he edited "The Antiquarian and Architectural Year-Book," which was "intended to gather into one view all discoveries and proceedings for the year, both in primæval and mediæval antiquities." In this work he was aided by some of the most eminent scholars and antiquaries of the country. He wrote and published, between 1847 and 1850, the "Memorials of Ipswich," in two volumes, illustrated with great care. He subsequently was engaged for a time on the "Morning Post," but his health obliged him to resign, and he soon after accepted the situation of sub-editor of the "Norwich Mercury." He has left a large collection of MSS. on art and archæology, also many sketches and drawings of great value.

Nov. 20.—KINNEAR, DAVID, senior editor of the "Montreal Herald and Daily Commercial Gazette," died at Montreal, aged 55 years. He was a native of Edinburgh, the son of a banker, and a lineal descendant of the celebrated Col. Gardiner. He was admitted to the Scotch bar, but was engaged in mercantile business in London, where he had connections in the highest branches of commerce. He came to America

in 1835, and employed some time in various travels throughout the United States and Canada. In 1837 he was among the first to take up arms for the preservation of the province to the British Crown during the rebellion. Soon after, he became connected with the "Montreal Gazette," which position he relinquished to become a partner in the "Montreal Herald," of which paper he was chief proprietor at the time of his death.

Nov. 30.—KNOWLES, SHERIDAN. (See KNOWLES.)

Dec. 17.—THOMSON, MRS. KATHARINE (widow of the late Dr. Anthony Todd Thomson), died at Dover, England. She was well known to the public as an authoress, her first production being a "Life of Wolsey," written for the "Society for the Diffusion of Useful Knowledge," and much commended by Lord Brougham. A novel called "Constance"—her first venture in fiction—was very successful. "The Life of Raleigh," and the "Memoirs of the Court of Henry the Eighth," were followed by "Memoirs of Sarah, Duchess of Marlborough," and gave her a high position in literature. Her researches, and the reading requisite for these works, furnished her material for a series of historical novels, as "Anne Boleyn," "Ragland Castle," "The White Mask," "The Chevalier." In addition to these she published "Lives of the Jacobites," "Tracy, or the Apparition," and "Widows and Widowers," one of the most popular of her novels. After Dr. Thomson's death, in 1849, she resided on the Continent for some years, and upon her return to England, published "Court Secrets," "Faults on Both Sides," and the "Life of Villiers, Duke of Buckingham." The most popular of her later works were written conjointly with her son: the "Queens of Society," and "Wits and Beaux," published under the pseudonyms of Grace and Philip Wharton. The third and last of this series, "The Literature of Society," was entirely her own. During a long residence in London, her house was the resort of those who were eminent in science, letters and the arts. In 1860, her son and fellow-worker, John Cockburn Thomson, was accidentally drowned at Tenby—a shock from which his mother never recovered.

Dec. 17.—MONSON, Hon. WILLIAM JOHN, sixth baron, died at Paddington, England. He was born in Tanjore, Presidency of Madras, May 14, 1796, and at an early age was sent to England for his education, and entered Christ Church College, Oxford, in 1814, graduating in 1818. Before taking his Bachelor's and his Master's degrees, he made two tours to the East, the results of which were published in 1817 and 1820, under the modest title of "Extracts from my Journal." Istria, Dalmatia, Sicily, Malta, and Calabria, were among the countries visited and described in these tours. Though admitted to the bar, he did not practise his profession, but devoted himself to literary and scientific pursuits, and especially to archæology and antiquarian studies. He succeeded

to the peerage in October, 1841, and in 1846 was appointed deputy-lieutenant of Lincolnshire. He had given much attention to the local history of Lincolnshire, and published several monographs on the subject.

*Dec. 18.*—**WEALE, JOHN**, an English publisher, died at Canterbury Villas, Maida-vale, aged about 70. He had, in a business career of more than 40 years, made it his great object to suggest, create, and mature works of acknowledged value and service to professional men and others. His rudimentary series of scientific works, many of them edited by himself, have contributed largely to the popularization of science, and he had also compiled and edited several works of greater size on scientific topics. Among these were "Divers Works of Early Masters," published in 1841; "Weale's Drawing Books for Engineers and Architects," 1834; "Weale on the Making of American Railways, with Illustrations," 1848; "Weale's Papers of Architecture and Archæology," 500 plates, 1844; "Weale's Survey of London," 1852.

*Dec. 18.*—**STONEHOUSE, REV. WM. BROCKLEHURST**, D.C.L., archdeacon of Stowe, and vicar of Owston, died at Owston Ferry, aged 69. He was educated at Brasenose College, Oxford, became B.A. 1816, M.A. 1819, D.C.L. 1845. He was advanced priest in 1816, appointed vicar of Owston in 1821, and archdeacon of Stowe in 1844. He had restored the church at Owston at a heavy expense, and rebuilt the church at West Butterwick, and in every way contributed to the benefit and happiness of his parishioners. He was the author of five or six religious works, one of which, "The Crusade of Fidelis," was very popular; and had also published several valuable archæological works.

*Dec. 19.*—**SOLOMON, ABRAHAM**, an eminent English painter, died at Biarritz, of pleuropneumonia, aged 89. Among his paintings, which had attained a high reputation, may be mentioned, "Waiting for the Verdict;" two companion pictures, "Second Class" and "First Class," in which a sailor lad's departure from home and return as a midshipman are set forth in two scenes in railway carriages; "The Lion in Love," a plethoric old general threading the needle of a pretty young coquette; and the "Lost Found."

*Dec. 27.*—**CHAPMAN, REV. JOHN, B.D.**, secretary of the Church Missionary Society, died at Islington, England, aged 49. He was educated at St. John's College, Cambridge, graduating in 1836, and was subsequently elected to a fellowship in that college, which he resigned in 1840, and went out as a missionary of the Church Missionary Society to take charge of the Cotayam College in Travancore. After 10 years' efficient service there, during which he had greatly elevated the character of the college, he removed in 1850 to Madras to take charge of the Church Missionary Seminary in that city. In 1858 he was compelled to return on account of the state of his health, and soon after his re-

turn was appointed secretary of the society, which position he held till his death. Aside from the manifold and arduous labors of this position, he contributed largely to the theological literature of the day. His "Answer to the Essays and Reviews," published in 1861, received high commendation as one of the ablest defences of the truth called out by the controversy.

*Dec. 29, 1862.*—**MORLOT, FRANCIS NICHOLAS MADELEINE**, cardinal of the order of priests, archbishop of Paris, died in Paris. He was born at Langres, department of Haute Marne, Dec. 28, 1795, of humble parentage. He early showed a decided vocation for the clerical profession, and entered, as a student, the Ecclesiastical College of Dijon. After teaching for a while as a private tutor, he received priest's orders, and was soon after appointed grand vicar of the diocese of Dijon. In 1839 he was raised to the see of Orleans. In 1841 he received the decoration of the legion of honor, and in 1842 was appointed archbishop of Tours. In 1853 he was created cardinal, and in that capacity took his place in the Senate. In 1857, on the murder of Archbishop Siboux, of Paris, he was translated to that see, and the same year made grand almoner of the empire, and in 1858, member of the council of regency and privy council. Soon after, he was promoted to the rank of commander of the legion of honor. He was the author of several works mostly on church topics.

**OHIO**, the most populous of the Western States, increased in population 859,182 during the ten years ending in June, 1860. The further details of the census relative to Ohio, which have been made up, will be found under **UNITED STATES**, to which the reader is referred.

The governor of the State is David Tod, whose term of office commenced Jan. 1, 1862, and continues during two years. The governor, lieut.-gov., treasurer, and Legislature are elected for two years, and on the alternate years, the secretary of State, attorney general, State librarian, &c., are chosen. The judges of the Supreme Court are elected by the people for five years. The term of office of one expires in each year.

The electors of the State have been divided into two political parties—the republican and the democratic. The election is held on the second Tuesday in October. The officers to be chosen in 1862 were, a judge of the Supreme Court, a secretary of State, attorney general, school commissioner, and members of the Board of public works; also nineteen members of Congress. A convention of the democratic party assembled at Columbus, on the 4th of July, and nominated the following officers: For judge of the Supreme Court, — Ranney; secretary of State, W. W. Armstrong; superintendent of public works, James Gamble; school commissioner, O. W. Cathcart. The views of the convention on national affairs were expressed in the following resolutions;

1. *Resolved*, That we are, as we ever have been, the devoted friends of the Constitution and the Union, and we have no sympathy with the enemies of either.

2. *Resolved*, That every dictate of patriotism requires that, in the terrible struggle in which we are engaged for the preservation of the Government, the loyal people of the Union should present an unbroken front; and therefore all efforts to obtain or perpetuate party ascendancy by forcing party issues upon them, that necessarily tend to divide and distract them, as the Abolitionists are constantly doing, are hostile to the best interests of the country.

3. *Resolved*, That the Abolition party, by their denunciation of the President whenever he has manifested a conservative spirit, by their atrocious defamation of our Generals who were exposing their lives for their country, and who needed and merited its hearty support, by their acts and declarations tending to promote insubordination in our armies, and a want of confidence in their commanders, and by their persistent representations of all conservative men in the loyal States as sympathizers with the rebels, have given immense aid and comfort to the rebel cause, and encouraged them to hope for ultimate success.

4. *Resolved*, That we have seen with indignation the intimation of the Governor of Massachusetts, that that State will be slow in furnishing her quota of troops, unless the war be carried on for purposes of emancipation. When the Nation is straining every nerve, and pouring out its blood and treasure like water, to preserve its existence, it is monstrous that a conditional Unionism that places Abolitionism above the Constitution, and the success of a party above the integrity of the Republic, should thus rear its head in high places and seek to dictate the conduct of the war.

5. *Resolved*, That while we would mete out merited and legal punishment to the plotters of, and leaders in, the rebellion, we are opposed to the contemplated sweeping and indiscriminate acts of confiscation and emancipation, by Congressional legislation or Executive proclamation, because:

I. We do not believe that such acts would be constitutional.

II. We believe that by driving the rebels to desperation, and converting Union men at the South into rebels, they would have the effect to indefinitely prolong the war, afford a pretext for foreign intervention, and render the restoration of the Union next to, or quite, impossible.

III. Because, if practicable and carried out, they would engender a feeling of bitterness between the different sections of the Union that would not be allayed for generations to come, and that would be an ever-present cause of danger and disturbance to the public peace, a source of perpetual weakness in the Government, and an ever-present incentive to foreign Powers to interfere in our domestic concerns, and to promote a disruption and overthrow of the Republic.

IV. Because they would destroy, in a great degree, if not entirely, for many years to come, the industrial interests of a large section of the country, and most injuriously affect the interests of the whole people.

V. Because the immediate and indiscriminate emancipation of the slaves would be an act of inhumanity to them.

VI. Because such an emancipation would throw upon the border free States, and especially upon Ohio, an immense number of negroes to compete with and underwork the white laborers of the State, and to constitute, in various ways, an almost or quite unbearable nuisance, if suffered to remain among us. And we would deem it unjust to our gallant soldiers to see them compelled to free the negroes of the South and thereby fill Ohio with a degraded population to compete with these same soldiers upon their return to the peaceable avocations of life.

[No. 7 condemns the Legislature for not prohibiting the immigration of negroes into Ohio; No. 8 opposes taxation for the purchase of the freedom of slaves, and denounces the frauds and corruptions of the Federal

Administration; No. 9 praises the bravery and devotion of the Ohio troops; No. 10 condemns the refusal of the Legislature to let the soldiers vote; No. 11 protests against all violations of the Constitution.]

*Resolved*, That we hold sacred, as we do all other parts of that instrument, the following provisions of the Constitution of the United States:

"The trial of all crimes, except in cases of impeachment, shall be by jury; and such trial shall be held in the State where the said crimes shall have been committed."

"Congress shall make no law respecting an establishment of religion, or prohibiting the free exercise thereof; or abridging the freedom of speech, or of the press; or the right of the people peaceably to assemble, and to petition the Government for a redress of grievances."

"The powers not delegated to the United States by the Constitution, nor prohibited by it to the States, are reserved to the States, respectively, or to the people."

"The right of the people to be secure in their persons, houses, papers and effects against unreasonable searches and seizures, shall not be violated, and no warrant shall issue but upon probable cause, supported by oath or affirmation, and particularly describing the place to be searched and the persons and things to be seized."

"No person shall be held to answer for a capital or otherwise infamous crime, unless on a presentment or indictment of a grand jury, except in cases arising in the land or naval forces, or in the militia, when in active service, in time of war and public danger; nor to be deprived of life, liberty, or property, without due process of law; nor shall private property be taken for public use without just compensation."

"In all criminal prosecutions the accused shall enjoy the right to a speedy and public trial by an impartial jury of the State and District wherein the crime shall have been committed, which District shall have been previously ascertained by law; and to be informed of the nature and cause of the accusation; to be confronted with the witnesses against him; to have compulsory process for obtaining witnesses in his favor, and to have the assistance of counsel for his defence."

And we utterly condemn and denounce the repeated and gross violation by the Executive of the United States, of the said rights thus secured by the Constitution; and we also utterly repudiate and condemn the monstrous dogma that in time of war the Constitution is suspended, or its powers in any respect enlarged beyond the letter and true meaning of that instrument.

*Resolved*, That we view with indignation and alarm the illegal and unconstitutional seizure and imprisonment, for alleged political offences, of our citizens without judicial process, in States where such process is unobstructed, but by Executive order by telegraph or otherwise, and call upon all who uphold the Union, the Constitution, and the laws, to unite with us in denouncing such flagrant violation of the State and Federal Constitutions and tyrannical infraction of the rights and liberties of American citizens; and that the people of this State cannot safely and will not submit to have the freedom of speech and freedom of the press, the two great and essential bulwarks of civil liberty, put down by unwarranted and despotic exertion of power.

The republican electors were represented in a convention designated "Union State Convention," which assembled at Columbus, August 21, and organized by the election of Benj. F. Stanton as president. The following candidates were nominated: secretary of State, William S. Kennon; attorney general, Chauncey N. Olds; school commissioner, Wm. D. Henkle; board of public works, Ira B. Gregory. The views of the convention were expressed by the following resolutions:

*Resolved*, That we adhere to the opinions and principles put forth at the Union Convention held in Columbus, Sep. 5, 1861.

*Resolved*, That we have undiminished confidence in the National Executive in the conduct and prosecution of the war, and we pledge to his support all the moral and physical power of the State.

*Resolved*, That the conduct of the Executive of Ohio, in his efforts to aid in the vigorous prosecution of the war, merits and receives our unqualified approbation.

*Resolved*, That the unexampled promptness of our volunteer army in their enlistment in the service of their country, and the high courage with which they have borne themselves in the field, merits and receives the confidence and gratitude of the country.

The votes of the electors were cast as follows:

Democrat.		Union.	
Armstrong.....	184,882	Kennon.....	178,755
Ranney.....	185,078	Backus.....	178,115

The vote for members of Congress was as follows:

	Democrat.	Republican.
1st. Dist. ....	7,445	6,418
2d. " .....	7,212	7,081
3d. " .....	11,770	13,027
4th. " .....	10,318	9,435
5th. " .....	10,561	6,202
6th. " .....	10,087	9,820
7th. " .....	10,872	10,100
8th. " .....	9,012	8,642
9th. " .....	11,765	10,523
10th.* .....	5,232	6,903
11th. " .....	8,605	6,702
12th. " .....	13,721	8,087
13th. " .....	12,763	9,699
14th. " .....	10,490	10,454
15th. " .....	10,332	9,133
16th. " .....	12,299	9,999
17th. " .....	9,085	10,018
18th. " .....	4,183	9,293
19th. " .....	6,768	13,238

The result was the choice of democratic members of Congress in the 1st, 2d, 4th, 5th, 6th, 7th, 8th, 9th, 11th, 12th, 13th, 14th, 15th, 16th districts; and republican members in 3d, 10th, 17th, 18th, 19th districts.

The Legislature elected in 1861 was divided as follows:

	Senate.	House.
Democrats .....	8	24
Republican & Union	26	78

This Legislature, at its first session, on the 14th of March, adopted the following resolutions:

Whereas wicked and ambitious traitors have, without cause, plunged our nation into civil war, disregarding all fraternal obligations; falsifying the most sacred injunctions that can be applied to the conscience—their solemn oaths; forcing upon us an expense of millions of money and incalculable loss in the prostration of business, and untold miseries in the sacrifice of human life; and whereas recent developments manifest a disposition on the part of some of the leaders of the rebellion to ask terms and sue for peace: Therefore,

*Be it resolved by the General Assembly of the State of Ohio*, That in view of the loss of loyal blood and treasure, our Government cannot, without loss of character and injustice to the noble dead that have fallen in defence of its authority and the rights of humanity, except less than an unconditional submission to the supremacy of the Constitution and the laws.

*Resolved*, That the future peace of the United States and the permanency of the Government, as well as the

best interests of humanity throughout the world, demand the speedy trial and summary execution of all leading conspirators in the attempt to destroy the Government; and in the name of the people of Ohio, who have given their money and lives without stint for the preservation of our liberties, we protest against the entertainment of any proposition for settlement other than unconditional submission to rightful authority and the condign punishment of the authors of the rebellion.

At many points on the Ohio river, above Cincinnati, the State was for many weeks threatened with invasion by Confederate guerrillas. Most of the summer and fall the people were in a state of alarm. The unusually low stage of water in the river caused it to become but a slight protection to the citizens of Ohio. Early in October, however, the War Department concentrated a sufficient force in western Virginia to drive out the Confederates. Upon the approach of the Confederate troops, under Gen. Bragg, into Kentucky, the southern portion of Ohio was threatened, and the governor appealed to the citizens to arm themselves and repair to the border. From the fields, workshops, stores, offices, and pulpits, both old and young very generally turned out armed with their own weapons. The numbers were unknown, but multitudes were sent home for lack of transportation.

Under the two calls of the President for three hundred thousand men each, the quota of Ohio was 74,000. At the time when these calls were made the State had raised, by voluntary enlistment, 115,200. Of the quota of the State 37,000 were, by an act of Congress passed July 17, and the President's order issued August 4, liable to be drafted on failing to volunteer. The total militia strength of the State was 425,147. Subsequent to the President's order a day was fixed for drafting, and during this interval 62,000 volunteered, leaving about 12,000 to be drafted. Of this number, about 4,800, either in person or by substitute, volunteered for three years; 2,900 were discharged for various reasons; 1,900 failed to respond to the draft, thus leaving 2,400 for the number actually sent to the field for service under the draft. The deficiencies have been made good by voluntary enlistments since the draft.

The number of inmates of the benevolent institutions of the State during the year was as follows:

Lunatic Asylums (one omitted) .....	562
Blind Asylum .....	120
Deaf and Dumb .....	150
Idiotic Asylum .....	57
	889

Their total expense to the State during the year was \$135,487.

The number of children in attendance at the common schools for the year 1862 was 723,669; male teachers, 10,559; female do. 10,981; number of school houses, 10,422; value, \$4,649,908; receipts for school purposes, \$2,765,866; expenditures, \$2,501,068.

There are twenty-three colleges in the State,

\* Union, 5,781.



of which three are female, and two admit students of both sexes; six are under the charge of the Methodists, five under the Presbyterians, three Roman Catholic, two Lutheran, and one Episcopal, Baptist, Congregationalist, New Jerusalem, Unitarian, and United Brethren, each. There is also a law school at Cincinnati, and three or four medical schools in the State.

The receipts of the State treasury for the year ending Nov. 15th, 1862, were \$6,289,828; payments therefrom, \$5,890,048; balance, \$478,456.

The State debt, on Nov. 15, was \$14,141,666. The interest due out of the State has been paid in coin, which was furnished by the banks in redemption of their own notes at one half of one per cent. premium. This was made a condition of their suspension of specie payments being legalized by the Legislature.

The length of the railroads of the State completed and in progress is 3,280 miles, at a cost of \$150,166,949.

OREGON, situated in the northwestern extremity of the United States, on the Pacific Ocean, had a population in 1860 of 52,465, which is an increase during the preceding ten years of 39,171. For the details of the census relative to this State, the reader is referred to the article on the UNITED STATES.

The governor of the State is Addison C. Gibbs, whose term of office expires Sept. 1866. The governor, secretary of State, treasurer, and State printer are elected for four years. The last election was held on June 2, 1862. The citizens were divided into two parties at the election: one known as Douglas democrats and republicans; the other regular democrats, or, as they were called, Breckinridge democrats, having voted for John C. Breckinridge for the presidency in 1860.

The vote for governor cast at the election was for Gibbs, Union, 7,039; Miller, democrat,

8,450. For McBride, Union, for Congress, 6,809; for Miller, democrat, 3,632. The Legislature contained a majority of the Union party, and elected Benj. F. Harding to the United States Senate by 9 majority over all others.

The Legislature assembles biennially on the second Monday of September. The Senate consists of sixteen members elected for four years, and the House of thirty-four members elected for two years.

The Supreme Court consists of five judges, who are chosen in districts by the electors and who hold the courts for those districts. They are elected for six years.

The receipts into the State treasury for two years ending September 8, 1862, were \$91,788, and the expenses during the same period were \$55,831. The State tax payable in 1861 was \$48,475 on a valuation of property at \$23,886,951; and the tax for 1862 was \$43,117, on a valuation of \$21,288,931.

Four colleges have been incorporated in the State, one of which is an agricultural college, and very liberal grants of land have been made by Congress for common schools.

Western Oregon is well adapted to agricultural pursuits. It has extensive valleys, where the growth of various fruits is unsurpassed. The valleys in eastern Oregon have a rich soil and hot summers. The climate is comparatively mild and not particularly moist, except in that portion lying west of the coast range of mountains. In eastern Oregon it is dry with little or no rain except in autumn. This part of the State is rich in mineral wealth.

No troops have been called from Oregon during the war, but many of the citizens have joined the troops raised in California. A regiment raised in the State is also performing garrison duty at posts where United States troops were formerly stationed.

## P

PASQUIER, ETIENNE, DENIS, Duke, a French statesman, born in Paris, April 23, 1767, died in that city, July 5, 1862. He was educated at the College of Juilly by the Oratorians, became a councillor in the Parliament of Paris before he was of age, and as such was one of the parties exiled to Troyes in the last years of the old monarchy. His father perished on the scaffold in 1794, and young Pasquier exerted himself so energetically to save him that he was near sharing the same fate. He occupied several important posts under the empire, was councillor of state and procureur general, a baron, commander of the legion of honor, and, finally, was appointed prefect of police. It was while he held this office that Malet made his daring attempt to overthrow the government during Napoleon's absence in Russia. Pasquier's pres-

ence of mind defeated the plan, and the emperor retained him in his post. After the abdication of Fontainebleau, he recognized the new government and did his best to induce the Parisian population to submit to the authority of the Bourbons. On their restoration he withdrew from political affairs, but accepted the post of director general of the ponts et chaussées. On the return of the emperor from Elba, he resigned, and exercised no public function during the Hundred Days. On the second restoration he was offered the post of keeper of the seals in the first cabinet formed by Prince Talleyrand in 1815. He was elected deputy for Paris in 1816, joined the ministry of 1817, and in 1819 was associated with M. De-cazes in the formation of a new cabinet, in which he held the portfolio of foreign affairs.

After the resignation of M. Decazes, M. Pasquier became the real head of the government, and through his courage and superior judgment was enabled to pass safely through that stormy period. He adhered to the revolution of July, 1830, and was treated with favor by Louis Philippe, who made him president of the Chamber of Peers—and as such he presided at the trial of Prince Louis Napoleon (now emperor of the French), and his associates, for the Boulogne attempt. In 1844 he received from Louis Philippe the title of duke. He was elected member of the French Academy in 1842. His public career ended with the revolution of 1848.

**PATENTS.** During the year 1861, and early part of 1862, there was a falling off in the business of the Patent Office, mainly resulting from the effects of secession in taking off a large number of inventors and mechanics from their workshops to swell the ranks of the Federal army; and the general depression of the business in the country also tended to the same result.

The operations of the Patent Office, compared with the previous years, have been as follows:

	1860.	1861.	1862.
Number of applications filed, . . . . .	7,653	4,648	5,063
Number of patents issued, including reissues and designs, . . . . .	4,819	3,340	3,521

During the last quarter of 1862, and first quarter of 1863, the business of the Patent Office increased considerably.

The financial condition of this branch of the public service is as follows:

Balance of patent fund, January 1, 1862, . . . . .	\$5,416 55
Total receipts of patent office for 1862, including an appropriation of \$50,855 49, . . . . .	\$15,754 99
Total, . . . . .	\$21,171 54
Total expenditures for the year 1862, . . . . .	152,810 39

Balance of patent fund, January 1, 1863. \$38,361 15

The patent law of March, 1861, has proved a benefit to inventors, and was the means of establishing many important changes in the mode of granting patents, most of which have been fully laid before the public.

The decisions of the board of examiners-in-chief (created by that law) have shown marked ability, and led to a more uniform and liberal policy in the issue of patents, as will be seen from the fact that about seven tenths of the patents applied for are granted: this is a large advance on the proportion for many former years.

By this law of March, 1861, fifteen dollars was required on filing each application, and twenty dollars additional before the patent was allowed; but there was no time specified in which this additional sum was to be paid, hence many inventors left their applications for a year or more before making this additional payment, for the purpose of prolonging the term of their protection. This manifest error and wrong has been rectified by a recent act

of Congress, requiring said additional fee to be paid within six months, or the patent would be considered abandoned, unless shown to the satisfaction of the commissioners that the delay was unavoidable.

In the following brief synopsis of some of the patents granted in the year 1862, sufficient space cannot be devoted to the subject to mention all the inventions that appear to have special value, and besides this it often happens that months, or even years, elapse before the real merits of an invention become known, and hence it is impossible to form an accurate judgment as to what will ultimately prove of special value and importance.

In future volumes it is proposed to extend these notices of inventions to a greater length than can be done in this volume.

**Beer Cooling.**—The brewing of ale, porter, and beer has been much improved during the few years past by the aid of scientific appliances that have transformed the manufacture into a regular chemical process, instead of being dependent on the skill and judgment of the brewer. Perhaps nothing has effected a greater change than the cooling apparatus invented by J. L. Baudelot, of Paris, and patented in this country, Nov. 1, 1859, and reissued Jan. 28, 1862.

The cooling of beer upon the old plan was effected in a deep narrow vessel, so that the atmosphere might come in contact with the same as little as possible, the cooling being effected by water circulating through pipes within this vessel. The improvement above mentioned consists in a vertical range of horizontal pipes. The beer runs from a trough upon the top pipe of the range, and thence trickles down upon the next pipe, and so on to the bottom pipe, so that it runs in thin film over the entire surface of the pipes. These pipes contain water, which enters the bottom pipe of the range, and circulates upward and flows away from the top pipe; hence the conditions of heat are inverted in the respective liquids, the beer in a heated state trickling downward becomes entirely cool, while the water entering cold, and running upward, passes away at the top in a heated state. Besides being much more rapid than the coolers heretofore made, this apparatus improves the quality of the beer by exposure to the atmosphere.

**Ballast Boxes.**—Steamboats require ballast boxes that are moved from place to place to keep the boat level in the water as the passengers may go from side to side, or as the deck load may be removed. Heretofore these ballast boxes have required the combined strength of several persons to move them, and the necessity for their removal often arises when the deck hands are otherwise occupied.

The invention patented Feb. 11, 1862, by T. Fowler, consists in a crank and gearing applied to the castor wheel of the ballast box, by which device one man can with ease move the said box from place to place as required, with as

much speed as is necessary, although the motion is comparatively slow.

*Canteens.*—Anything that will promote the health of the soldier should receive consideration, especially while so many valuable citizens have left the comforts of home for untried exposure and hardship. Pure water is of vital importance to health, and yet the soldiers' canteens usually employed impart, to many kinds of water, a poison, arising from the action of the water on the metal of which they are made. L. Cantel patented (Oct. 11, 1862) a canteen made of sole leather, saturated with a peculiar varnish, and pressed up in moulds to form the halves of the canteen; the insides are lined with pure tin foil, and then the halves united with rivets. The canteen is light and strong, and at the same time is not affected by liquids carried in it.

*Dredging Machine.*—A patent was granted in 1848 to E. Morris for a scoop and elevator for dredging, which was extended in 1862 for seven years.

This invention is one of those that has earned an enviable reputation. The old style of dredging machine scrapes the mud up from the bottom of slips and basins, and in so doing raises a large amount of water unnecessarily with the mud, and it is very difficult to work down into the corners of slips.

The machine above named is composed of a scoop formed of two quarters of a cylinder worked by chains, and attached to vertical poles; the scoop is lowered down, and when it rests upon the mud the said quarter cylinders are drawn together, cutting down into and enclosing the mud within the half cylindrical scoops thus formed; the scoop is then raised, swung over a scow, and opened to deliver its contents.

This character of dredging machine effects a great saving in the cost of excavation, and does work that no other machine has been able to perform.

In obtaining the extension, it was shown that slips and basins had been excavated to a depth of thirty feet, and the mud and earth swung across the bulkhead in the machine and delivered on the inside for filling in the land. This machine has also been used for tearing to pieces and removing sunken vessels, and for drawing up old piles and removing piers, in which case the stones used for filling in the crib-work have been taken up and the crib-work itself broken to pieces and removed.

*Fusee or Safety Train.*—Blasting rocks, both under water and upon land, is always attended with danger from premature explosion, and also from defects in the fuse, causing the same to smoulder for a long time, instead of burning regularly, and from this cause blasts sometimes explode just as the workmen commence to examine and remove the defective fuse.

The above-named invention, patented Jan. 7, 1862, removes the risk entirely, for the ex-

plosion will be instantaneous, or, if the fuse is broken or defective, there is no possibility of an explosion. A composition, in a moist state, is applied in a thin line on a strip of paper, and this paper is then folded and coated with gutta percha, or varnish, and cords are applied longitudinally, to give the necessary strength; these are kept in place by a winding of string. The composition employed is of an explosive, but not a detonating nature, and will ignite at the rate of a mile in the space of five seconds of time, thus approaching the velocity of electricity. The speed of the explosion is such that the paper, although torn to pieces, is not ignited; hence the explosion of the gunpowder, to which this fuse connects, is instantaneous, or, in case of failure from improper management, there is no danger from immediately inserting a new fuse, because there is no fire left in the defective fuse.

*Firearms and Implements of War.*—The war which the country is engaged in at present, has caused many improvements to be made in firearms and implements of warfare, in fact the art of war has been changed radically within the past two years. The perfection of cannon and projectiles has inaugurated a perfection in armor for resisting them, and so each side has alternately triumphed; all have heard of the iron-plated monster the "Merrimac," with her iron prow making sad havoc with the Federal fleet off Fortress Monroe, in March last, and of the invulnerable Monitor that arrived in time to check her career and cause her retreat to Norfolk; and then mention is made of such projectiles as those invented by C. W. Stafford (patented Jan. 27, 1868), capable of penetrating the iron turrets of these Monitors.

Justice cannot be done in this article to those inventors who have devoted time, thought and money to devising implements of war, hence but few of these inventions can be mentioned.

*Accelerating Projectiles.*—The sudden starting of a cannon or musket ball from a state of rest to a velocity nearly equalling that of sound causes a great strain on the musket or cannon, hence the breech has to be the strongest part. The powder, being, ordinarily, all in one mass when ignited, produces great pressure at the breech; but the pressure of the gases decreases, in consequence of the expansion, before the projectile leaves the barrel, hence said projectile is not acted upon with as much power at the time of leaving the barrel as when it was started. The conditions of pressure should be reversed, so that the ball would be started gradually, and its velocity increased and followed up by an increase of pressure. This result is attained in a cartridge patented by Alexander Shannon, March 4, 1862, in which a given charge of powder, instead of being in one mass, is divided by diaphragms of perforated felt, or other materials, the section of powder next the ball being the largest,

that next to the rear smaller, and the extreme rear section being still less; on being fired, the ball and forward sections of powder are started by the explosion of the first section of powder, and the ball is accelerated by the explosion of the successively larger charges of powder, the last explosion taking place just before the ball leaves the gun, so that its velocity is accelerated by a constantly increasing pressure. The experiments with this improvement show a much greater range and penetration than was ever before attained with the same amount of powder. The recoil of the gun with this mode of acceleration is very much lessened.

*Revolving-chambered pistols* have also been improved and simplified; in letters patent granted to D. Moore, Jan. 7, 1862, the forward part of each chamber is rifled, and coincides with the rifling of the barrel, the ball is entered, in a metallic cartridge case, at the open rear end of the chamber, so that the act of slugging the ball in the rifle grooves tends to force the cylinder of chambers forward against the rear end of the barrel, and prevent the escape of gases at this point.

*Revolving guns* have been made and used that fire over a hundred shots per minute, and an accelerating gun has been invented in which the penetration of the projectile has been truly wonderful, such as a half-inch steel bolt driven through two iron plates, each of which was more than two inches thick. Another invention of a rifle battery capable of firing over four hundred shots per minute has also been made; but of these, for prudential reasons, no farther description can now be given. Various valuable improvements have been made in breech-loading firearms, and in projectiles, also in armor plates and iron-clad vessels, for which, see NAVY, U. S.

*Hay Elevator.*—The hard labor of the farmer is gradually being done away with, and the power of horses and of steam are being introduced for the relief of human labor. Any improvement in this direction should be hailed with joy, for agriculture is the most noble and honorable employment, and many are kept from engaging therein in consequence of the excessive bodily labor connected therewith.

In former years, the most laborious work on the farm was throwing the hay from the wagon upon the mow in the hot and close barn; several attempts were made to unload by means of a fork drawn up by a rope passing through a block overhead, and thence through a block on the floor to a horse. These forks were all cumbersome, and more or less difficult to operate.

A Baptist minister in Greene co., N. Y., who found that the labor of pitching hay during the week rather incapacitated him for preaching on Sunday, thought he would devise a horse-pitchfork, and, after it was made, its operation exceeded the most sanguine expectations of himself and friends, and he patented the same

Sept. 30, 1862, and the fork has since taken several premiums at the various fairs where it has been exhibited.

This invention consists in curved tines extending downward and forward from the head of the fork; a short handle is connected to this head on the opposite side to the tines. A bail is hinged to the head of the fork, by which the same is lifted, and a rule-joint brace between the bail and handle keeps the handle down while the hay is being raised and conveyed away to its place on the mow; a rope drawn up by a horse is employed as before. The pulling of a cord by the attendant raises this rule-joint brace and handle, and draws the tines away from under the hay, and the further movement pulls the fork back to the attendant on the cart as the horse backs. This fork, though small, will raise about four hundred pounds of hay at once.

*Lamps.*—The introduction of coal oil has opened a new field for the inventive faculty, and it has been so thoroughly cultivated that it is difficult to select the most important of the inventions connected with lamps. The lamps that were in use when coal oil was first introduced were not adapted to burning the same, in consequence of the preponderance of carbon in such oils, but inventors have stepped in to supply the deficiency, and now lamps are constructed to burn the oil without smoke or smell, and with a very brilliant light. This result has been the most perfectly attained in lamps that employ a glass chimney, although several have been made, patented, and introduced that burn without any chimney or shade. See ILLUMINATION.

*Locomotives.*—With heavy trains and in ascending grades the driving wheels of engines are apt to slip. Sand has been used to prevent this, but that is only partially effective, and produced a grinding operation that wears flat places upon the wheels. An ingenious mode of giving adhesion to locomotive wheels was patented by T. Selleck, Sept. 16, 1862, in which the metal known as "Franklinite" is used in place of sand. This metal is very hard, and, when properly prepared, can be pounded up into small lumps or grains. By allowing a small stream of this granulated "Franklinite" pig metal to run on the rails for twenty or thirty feet, the slipping of the wheels will be prevented for a long distance, because these metallic grains are, by the weight, imbedded in the tires of the driving wheels, and act like fine cog teeth upon the surface of the rails to prevent slipping.

*Locomotive Trucks.*—If the railroads of our country were perfectly straight there would be but few instances of running off the track, but as curves are necessary, many different devices have been made and patented for ensuring greater safety in travelling over them. The most recent and effective device for ensuring safety in running over curves, as well as preventing accidents by contact with obstructions

or broken rails, has been invented by Alba F. Smith, superintendent of the Hudson river railroad, and by him patented Feb. 11, 1862.

This invention consists in introducing pendant links between the truck frame and the locomotive, in such a manner that the truck can move laterally under the forward end of the engine. The importance and necessity of this will be understood from the following:

Locomotives generally have four or six driving wheels; if these are placed on a curved track, and a line projected forward from the plane in which these wheels stand, it will be found that the curved track diverges either one way or the other from that line; now if the front of the engine itself were pulled around, so that the truck wheels (standing in the same plane as the drivers) could set upon the track, the flanges of the respective wheels would press against the sides of the track, producing great friction and wear, and always tending to make the locomotive run off the outer rail of the curve; this is substantially the case in the ordinary locomotive, but by allowing the truck to traverse laterally under the forward end of the engine, as well as to turn on its centre bolt, the drivers are allowed to retain their proper position on the track and travel freely around the curve, while the truck wheels also travel as freely around the curve as they would do if on the ordinary cars.

This improvement has been introduced on some of the best railroads in the country, and gives great satisfaction.

The patent in question, and some others granted in previous years for accomplishing the same general objects by different mechanism, are owned by the Locomotive Safety Truck Company of New York.

*Machine for Planing Wood Mouldings.*—The casual observer cannot help noticing the large amount of wood mouldings that are now used in buildings, in comparison with what was used fifteen or twenty years since. This arises from the fact that mouldings are produced by machinery at a much less cost than was possible when planed by hand. A machine for planing mouldings was patented by A. T. Serrell, May 16, 1848, and extended for seven years from May, 1862, in which a strip of wood sawed diagonally, so as to save material, is fed into the machine by a roller that only acts upon the parts where most wood has to be cut away, thereby not injuring the portion of the wood required for the moulding itself. A rotary cutter gives shape to the moulding, and a stationary plane smooths off the surface. This machine is in extensive use in many parts of the country.

*Shoes.*—The benefit resulting from the application of scientific principles to this branch of industry is apparent by examining the light and handsome rubber shoes now used in comparison with the shapeless article formerly made, with the top part as thick or thicker than the soles.

The same remark applies to leather shoes;

they have not been made on scientific principles; in ready-made shoes this is particularly the case, and almost every person knows that a boot or shoe has to be worn for a long time before it becomes as easy as an old shoe. This results mainly from the fact that the lasts have not been properly shaped, and the shoe has to become wrinkled on the top, in consequence of the sole bending upward at the toe. An improvement was patented Sept. 16, 1862, by N. Jones, in which the sectional last is made of a peculiar shape and measure, so that the shoe will be easy to the foot, and much more durable, because the parts take their proper strain, and the leather does not wrinkle and crack. This style of last and shoe is being extensively adopted.

*Skeleton Skirts.*—Since ladies adopted the skeleton skirt to keep the dress sufficiently distended for convenience in walking, many improvements have been made in the mode of construction, and it is to be hoped that these skirts will eventually be so perfectly made that all objections to them will be removed, for by their use the health of females is much improved, because the heavy weight of skirts formerly worn around the hips is removed.

An improvement that adds much to the durability of the skirts was patented Jan. 21, 1862, in which a piece of thin leather is introduced beneath each of the clasps that fasten the tapes to the hoops, whereby the cutting of the tapes by the metal of the clasps is prevented.

*Sewing Machines.*—The attention devoted by inventors to this branch of manufacture, has developed many important and valuable improvements. Among the improvements recently introduced by many of the sewing machine manufacturers, is a device for braiding; a small hole is made in the cloth presser near the opening for the needle, and the braid is led through this from a spool, so that the said braid can be stitched to the fabric in any configuration desired; the fabric being guided to the figure or pattern mark upon it.

The sewing machine of Messrs. Wilcox and Gibbs has also been improved so that it runs without being heard; the noise in sewing machines arises almost entirely from the feeding device where the metallic surfaces come suddenly together. In this machine the noise is prevented by the introduction of compressed leather at certain places in the feeding mechanism, and in practice this feed is found to be much more durable than those heretofore in use.

In the same machine a simple device is employed for determining the position of the hemmer; this consists of a small pin entering a hole in the bed, so that the hemmer cannot be misplaced and the stitching will always be on the proper part of the folded hem.

An important improvement in sewing machines was patented Nov. 11th, 1862, by J. A. & H. A. House, which is now the property of

the Wheeler & Wilson Sewing Machine Co. It is designed specially for the working of button and eyelet holes, although the range of the invention easily adapts the peculiar stitch claimed to various other purposes, in fact it may fairly be said to supply the link which was needed to make the chain of automatic movements in all classes of sewing complete.

For many years it has been the constant study of inventors to produce a machine which would throw a stitch over the edge of any fabric, so as to cover or bind it. The great sewing machine corporations of this country had expended many thousands of dollars in vain attempts to realize what was finally voted by almost all an impossibility, though acknowledged to be a necessity.

There had previously been several partially successful machines designed for this purpose invented and patented, but as the inventors always appeared to entertain the idea that the fabric must be moved under or around stationary needles, the machines, though ingenious, were of no practical value, it being found impracticable to form a perfect eyelet or rounded end of the button hole.

The idea of holding the fabric stationary and moving the needles around it, at the same time throwing what may be termed a double loop interlacing stitch over the edge of the hole, finally occurred to the Messrs. House, and they, after several attempts, succeeded in producing the machine mentioned.

The motive power or machinery to move the needles, one of which is straight and pierced with three eyes at the point, while the other is curved and has two eyes, is entirely below the bed plate. The straight needle is attached to an arm or shank which projects through a slot, above the bed plate, and this is fastened to a mandrel working from below; underneath the bed plate is a disk upon which are placed the spools, tensions, &c., and working through which in a slot is the curved needle or finger as it is called.

The cloth or garment in which the button or eyelet hole is to be worked, being punched, is placed upon the bed plate, the hole being directly over the slot, and the end of the needle shank projecting through it. The cloth is then pressed down upon the plate by what is called a foot or lever, and securely confined. On turning the crank, the needle shank rises, and then in its downward motion carries the straight needle directly through the edge of the fabric. The curved needle or finger which works through the hole brings its thread up over the edge of the cloth. This thread is caught by the straight needle in its downward course, then the finger draws down below the fabric and takes a loop from the straight needle, and ascending gives a loop again to the straight needle, thus forming a double interlacing stitch.

The disk, which is the most important portion of the machine, is mounted on a travelling

carriage moved backward and forward by a screw.

When the operator starts the machine, the needles being at the lower end of the button hole are moved along the edge or straight side, by the screw feed; on reaching the end, the screw feed is disconnected from the disk by a switch, and a gripe or rotating movement carries the needle around the end of the hole, forming a perfect crescent; so soon as this half circle is complete, the switch again pushes the screw into position, and this by a reverse motion drives the needles down the other side of the hole to the point of departure, forming a complete button hole. The size of the button hole is readily regulated by an index attached to the machine, and it will work a hole two inches in length, or an eyelet of less than an eighth.

An ordinary skilful operator will, with the assistance of two girls to finish or tie the ends, work one thousand fine button holes an inch and a quarter in length in ten hours, and all exactly alike. By the hand not more than forty can be made by the most accomplished operator in the same time.

As stated, the range of this stitch is not confined to button-hole making, but includes the sewing of sails, tents, awnings, indeed all classes of work requiring two straight or selvage edges to be bound securely and smoothly together.

PENNSYLVANIA, the second State in population in the Union, increased 594,329 in the number of inhabitants during the ten years ending June 1860. (*See UNITED STATES.*) The governor is elected for three years. The present incumbent is Andrew G. Curtin, whose term of office expires on the 1st of January, 1864. The State election is held on the second Tuesday of October. The officers to be chosen in 1862 were an auditor-general and a surveyor-general.

A convention, representing the democratic party of the State, assembled at Harrisburg on the 4th of July, and nominated for auditor-general Isaac Slenker, and for surveyor-general John P. Barr. The views of the convention on national affairs were expressed in the following series of resolutions:

*Whereas*, The American Constitution was ordained and established by our fathers in order to form a more perfect union, to establish justice, to insure domestic tranquillity, to provide for the common defence, promote the general welfare, and secure the blessings of liberty to posterity; therefore,

1. *Resolved*, That the only object of the democratic party is the restoration of the Union as it was, and the preservation of the Constitution as it is.
2. That to the end that the Union may be restored, and the Constitution and laws enforced throughout its whole extent, we pledge our hearty and unqualified support to the Federal Government in the energetic prosecution of the existing war.
3. That the true and only object of the war is to restore the Union, and to enforce the laws; such a purpose alone is worthy of the awful sacrifice which it costs us of life and of treasure, and with such a purpose alone can we hope for success, and those who from sectional

feeling or from party or private motives, would give any other direction to the efforts of our arms are unjust and unworthy to be intrusted with power, and would cause all our exertions, extraordinary and unparalleled as they are, to prove futile in the end.

4. That we justly view with alarm the reckless extravagance which pervades some of the departments of the Federal Government; and that a return to rigid economy and accountability is indispensable to arrest the systematic plundering of the public treasury by favorite partisans; and in view of the recent startling developments of fraud and corruption at the Federal metropolis and throughout the country, that we hold an entire change in the Administration to be imperatively demanded.

5. That the party of fanaticism or crime, whichever it may be called, that seeks to turn the slaves of the Southern States loose, to overrun the North, and to enter into competition with the white laboring masses, thus degrading and insulting their manhood by placing them on an equality with negroes in their occupations, is insulting to our race, and merits our most emphatic and unqualified condemnation.

6. That we denounce Northern abolitionism and Southern secession as the coöperating sources of our present calamities—alike treasonable to the Constitution and inimical to the Union. The only way to a restored Union and a respected Constitution, with return peace and prosperity, is through the overthrow of both.

7. That the democracy of Pennsylvania is equally opposed to all sectional legislation and geographical parties, which base their hopes for continued partisan success on the agrarianism of emancipation and hypercritical philanthropy, abolition, because neither is known to the Constitution, and both are intended to aid disunion and subvert the Constitution, and to prevent the restoration of unity, peace, and concord among the States and the people.

8. That the Constitution and the laws are sufficient for any emergency, and that the suppression of the freedom of speech and of the press, and the unlawful arrest of citizens, and the suspension of the writ of *habeas corpus*, in violation of the Constitution in States where the civil authorities are unimpeded, is most dangerous to civil liberty, and should be resisted at the ballot box by every freeman in the land.

9. That this is a Government of white men, and was established exclusively for the white race; that the negro race are not entitled to and ought not to be admitted to political or social equality with the white race, but that it is our duty to treat them with kindness and consideration as an inferior, but dependent race; that the right of the several States to determine the position and duty of the race is a sovereign right, and the pledges of the Constitution require us as loyal citizens not to interfere therewith.

10. That Congress has no power to deprive any person of his property for any criminal offence unless that person has first been duly convicted of the offence by the verdict of a jury, and that all acts of Congress like those lately passed by the House of Representatives, which assume to forfeit or confiscate the estates of men for offences of which they have not been convicted by due trial by jury, are unconstitutional, and lead to oppression and tyranny. It is no justification for such acts that the crimes committed in the prosecution of the rebellion are of unexampled atrocity, nor is there any such justification as state necessity known to our Government or laws.

11. That the Constitution and the Union and the laws must be preserved in all their proper and rightful supremacy, and that the rebellion now in arms against us must be suppressed and put down, and that it is our duty to use all constitutional measures necessary and proper to that end.

The republican, or, as it was called, "Union" State convention, assembled at Harrisburg on

the 17th of July, and nominated Thomas E. Coochran for auditor-general, and \_\_\_\_\_ for surveyor-general. The views of the convention on national affairs were expressed by the following resolutions:

*Resolved*, That the convention, representing as it does the loyal citizens of Pennsylvania, without distinction of party, reaffirm the sentiments embodied in the resolution adopted at the meeting of the loyal members of Congress at the national capitol, July 12, 1862: That we hold it to be the duty of all loyal men to stand by the Union in this hour of its trial, to unite their hearts and hands in earnest patriotic efforts for its maintenance against those who are in arms against it, to sustain with determined resolution our patriotic President and his Administration in their energetic efforts for the prosecution of the war and the preservation of the Union against enemies at home and abroad, to punish traitors and treason with fitting severity, and to crush the present wicked and causeless rebellion, so that no flag of disunion shall ever again be raised over any portion of the republic; that to this end we invite the coöperation of all men who love their country in the endeavor to rekindle throughout all the States such a patriotic fire as shall utterly consume all who strike at the Union of our fathers, and all who sympathize with their treason or palliate their guilt.

*Resolved*, That we have continued confidence in the honesty, capacity, and patriotism of President Lincoln and his constitutional advisers; that we approve the principles on which his policy, both foreign and domestic, has been conducted; that we sanction and sustain all the measures that he has found it necessary to adopt to guard the Government against the assaults of traitors, their sympathizers and abettors; and we esteem it eminently fortunate that, in this most trying crisis of our cherished Union, we have at the helm of public affairs one so upright, temperate, prudent, and firm as he has proved himself to be.

*Resolved*, That we cordially approve of the administration of Andrew G. Curtin, governor of this commonwealth, marked as it has been by extraordinary vigor in the discharge of all public duties, by untiring zeal in the cause of the country, and especially in recruiting forces for the national army, by enlarged and liberal care for the sick and wounded soldiers of the State, by a wise and prudent economy in the expenditures of the funds committed to his care, and by the unsparring devotedness of all its members, and in particular the governor himself, to the constant harassing, complicated, and novel labors which the exigencies of the great rebellion has imposed.

*Resolved*, That we acknowledge but two divisions of the people of the United States in this crisis, those who are loyal to its Constitution and every inch of its soil, and are ready to make every sacrifice for the integrity of the Union and the maintenance of civil liberty within it, and those who openly or covertly endeavor to sever our country, or to yield to the insolent demands of its enemies; that we fraternize with the former and detest the latter; and that, forgetting all former party names and distinctions, we call on all patriotic citizens to rally for one undivided country—one flag—one destiny.

*Resolved*, That the Government of the United States and its people, with an occasional exception among the reckless inhabitants, where this rebellion was fostered, have wisely and studiously avoided all interference with the concerns of other nations, asking and usually enjoying alike non-interference with their own, and that such is and should continue to be its policy. That the intimations of a contemplated departure from this sound rule of conduct on the part of some of the nations of Europe, by an intervention in our present struggle, is as unjust to them as it would be to us, and to the great principles for which we are contending; but we assure them, with a solemnity of conviction which admits of no distrust or fear, and from a knowledge of and a firm reliance upon the spirit and forti-

tude of twenty millions of freemen, that any attempt thus to intervene will meet a resistance unparalleled in its force, unconquerable in its persistence, and fatal to those whom it is intended to aid; and that it will tend only to strengthen and elevate the republic.

*Resolved*, That the skill, bravery, and endurance exhibited by our army and navy have elicited our admiration and gratitude; that we behold in these qualities assurances of sure and speedy success to our arms, and of rout and discomfiture to the rebels. That we urge the Government to aid and strengthen them by all the means in its power, and carefully to provide for sick, wounded, and disabled soldiers, and their families, to prosecute the war with increased vigor and energy until the rebellion is utterly crushed, the integrity of the Union in all its borders restored, and every rebel reduced to submission, or driven from the land, and that to accomplish these we pledge to our rulers our faith, our fortunes, and our lives.

*Resolved*, That the course of the Hon. David Wilmot in the United States Senate is manly, consistent, and eminently patriotic, and we hereby endorse him as a true and faithful representative of the loyal people of this State, and monuments shall be raised to teach posterity to honor the patriots and heroes who offered their lives at their country's altar; their widows and orphans shall be adopted by the nation, to be watched over and cared for as objects truly worthy a nation's guardianship.

The votes of the citizens were cast as follows:

	1862.	1861.
Democrat.....	219,140	230,239
Republican.....	215,616	262,408

The democratic candidates were thus elected.

The vote for members of Congress in the several districts was as follows:

	Democrat.	Republican.
1st. Dist. ....	7,720	6,278
2d. " .....	6,068	8,614
3d. " .....	8,243	8,285
4th. " .....	8,118	8,946
5th. " .....	9,548	9,605
6th. " .....	11,816	8,092
7th. " .....	6,445	9,891
8th. " .....	10,022	4,898
9th. " .....	6,650	11,174
10th. " .....	9,289	8,518
11th. " .....	11,676	2,592
12th. " .....	11,409	9,641
13th. " .....	7,703	9,520
14th. " .....	10,630	10,109
15th. " .....	9,748	11,965
16th. " .....	10,968	10,426
17th. " .....	8,323	7,556
18th. " .....	9,272	8,855
19th. " .....	9,462	9,954
20th. " .....	11,586	12,404
21st. " .....	10,234	10,009
22d. " .....	5,678	8,087
23d. " .....	7,685	8,989
24th. " .....	9,984	9,847

The democrats elected their candidates in the 1st, 6th, 8th, 10th, 11th, 12th, 14th, 16th, 17th, 18th, 21st, 24th districts, and the republicans in the 2d, 3d, 4th, 5th, 7th, 9th, 13th, 15th, 19th, 20th, 22d, 23d districts.

The members of the Legislature elected were as follows:

	Senate.	House.
Democrats .....	12	55
Republican .....	21	45

The financial condition of the State is as follows:

VOL. II.—45 A

The balance in Treasury Nov. 30, 1861, was—\$1,561,006 72  
Receipts during fiscal year ending Nov. 30, 1861, were as follows:—

Ordinary sources.....	\$4,047,822 39
6 per cent. loan act May 15, 1861.....	387,850 00
From various banks as an equivalent for coin for the payment of interest on public debt.....	140,768 80
Refunded cash, military.....	29,586 42
United States Government.....	606,740 62
	5,211,747 63

Total into Treasury for fiscal year ending Nov. 30, 1861.....\$6,763,353 35

The payments were as follows:

For ordinary purposes.....	\$8,083,110 06
Paid on State interest as an equivalent for coin.....	146,631 22
Military expenses, act April 12, 1861.....	7 62
Military expenses, act May 15, 1861.....	460,548 68
Military expenses, act May 16, 1861.....	1,217 26
Military expenses, act April 16, 1862.....	20,607 04
Military pensions, act May 15, 1861.....	400 64
Commissioners of Sinking Fund.....	427,881 51
Domestic creditors.....	105 32
Temporary loan redeemed.....	100,000 00
U. S. Government direct tax.....	350,000 00
	4,580,509 25

Leaving balance in Treasury Nov. 30, 1862.. \$2,172,844 10

Of which amount \$195,576 27 was the balance of unexpended military loan, as follows:

Balance of said fund Nov. 30, 1861.....	\$390,507 41
Receipts under act May 15, 1861.....	287,850 00
	778,357 41

Paid for military expenses as above.....	482,781 14
Paid for redemption of temporary loan.....	100,000 00
	582,781 14

Receipts from ordinary sources:

For year ending Nov. 30, 1862.....	\$4,047,822 29
Do. do. do. 1861.....	3,017,645 57
	\$1,030,176 82

Excess of receipts for 1862.....

Payments for ordinary purposes, excepting interest:	
For year ending Nov. 30, 1861.....	\$1,118,662 68
Do. do. do. 1862.....	1,028,345 77
	\$95,317 16

Decrease in expenditures of 1862.....

The receipts from ordinary sources of revenue for the year 1862 were in excess of the receipts of the year 1861, \$1,030,176 82 [the excess of interest paid in 1862 over that in 1861 being \$144,095 87], and the ordinary expenditures for 1862 were \$95,317 16 less than the year previous.

Amount of public debt of Pennsylvania, as it stood on Dec. 1, 1861..... \$40,580,666 08

Additional amount received at the State Treasury during the fiscal year ending Nov. 30, 1862, on Military loan, authorized per act of May 15, 1861.....	387,850 00
	\$40,968,516 08

Deduct amount redeemed at the State Treasury during the fiscal year ending Nov. 30, 1862, viz:

5 per cent. State stocks.....	\$268,809 49
4½ per cent. State stocks.....	50,000 00
4 per cent. State stocks.....	100,000 00
Interest certificates.....	17 25
Relief notes.....	1,411 00



Domestic creditors' certificates.	\$64 52	
Military loan, per act of April 12, 1861 redeemed.....	100,000 00	520,802 26

Public debt December 1, 1862..... \$40,448,218 82

Towards the extinguishment of the public debt, the Sinking Fund holds securities amounting to \$10,781,000, as follows:

Bonds of Sunbury and Erie Railroad Co.....	\$3,500,000 00
Bonds of Pennsylvania Railroad Co.....	7,000,000 00
Bonds of Wyoming Canal Co.....	281,000 00
	\$10,781,000 00

Should there be no extraordinary demand on the treasury, there can be appropriated from the large balance on hand and the increasing revenues, at least \$1,500,000 during 1863, toward the payment of the public debt.

The quota of the State of the direct tax of the United States was \$1,946,719, which was paid on the 14th of June, 1862, partly by a relinquishment of a portion of the sums claimed by the State from the Federal Government and partly in cash after deducting 15 per cent. for prompt payment. There is still due to the state, for advances to equip volunteers, about \$300,000.

The interest on the debt of the State was paid in August in specie at the cost of \$146,681, for the difference between specie and paper currency. This amount was refunded to the State by the banks under the act legalizing their suspension of specie payments.

Previous to the first call for volunteers on the 7th of July, the State had sent forward nearly 110,000 men. Liberal bounties were offered by municipal authorities throughout the State, and 88 regiments and three unattached companies of infantry were soon raised. On the 4th of August a draft of 800,000 militia was ordered by the President to serve for nine months. The enrolment and draft were conducted throughout the State under the laws of Congress, the State militia law being too defective for that object. The draft generally took place on the 16th of October. In some counties, a degree of resistance was manifested, but on the whole it was quite successful. Including the three months volunteers, Pennsylvania has furnished to the Federal Government more than 200,000 men since the commencement of the war, besides some 50,000 who were in service, or actually ready for it, as volunteer militia under a call made on Sept. 11, making in the whole more than 250,000 men.

Early in September the Confederate army under General Lee crossed the Potomac into Maryland, with the design, as was supposed, of invading Pennsylvania. On the 4th of Sept. the Governor issued a proclamation, calling upon the people to organize into companies, and to hold themselves in readiness to be ordered into actual service for the defence of the State. On the 11th he issued orders for 50,000 of the volunteer militia to rendezvous at Harrisburg. The call was promptly responded to, and a large force was immediately sent for-

ward to the Cumberland valley. Fifteen thousand of this volunteer militia were pushed forward to Hagerstown and Boonsboro' in the State of Maryland; ten thousand were posted in the vicinity of Greencastle and Chambersburg, and about twenty-five thousand were at Harrisburg, on their way to Harrisburg, or in readiness and waiting transportation to proceed thither. On the 24th of Sept. the entire force was disbanded, as the Confederate army had withdrawn from Maryland. For further details see ARMY OPERATIONS.

The following is the letter of Gen. McClellan to the Governor of Pennsylvania, acknowledging the services of the militia of that State:

"HEADQUARTERS ARMY OF THE POTOMAC,  
SHEARSPURG, Sept. 27, 1862. }

GOVERNOR: I beg to avail myself of almost the first moment of leisure I have had since the recent battles to tender to you my thanks for your wise and energetic action in calling out the militia of Pennsylvania for its defence when threatened by a numerous and victorious army of the enemy. Fortunately circumstances rendered it impossible for the enemy to set foot upon the soil of Pennsylvania; but the moral support rendered to my army by your action was none the less mighty. In the name of my army, and for myself, I again tender to you our acknowledgment for your patriotic course. The manner in which the people of Pennsylvania responded to your call, and hastened to the defence of their frontier, no doubt exercised a great influence upon the enemy. I am, very respectfully and sincerely, yours,

GEORGE B. McCLELLAN,  
Major General, United States Army.

In October a body of Confederate cavalry, with a battery of artillery, suddenly crossed the Potomac and made their way as far as Chambersburg, seizing such supplies as were useful to them, and committing other depredations. They went out of the State by crossing the South Mountain, and thus reaching the Potomac below Harper's Ferry. This march was made with so much celerity that the Confederates did not encounter any of the troops sent against them.

By an act of the Legislature, passed on March 29, 1813, it was provided that citizens absent from home in actual military service might exercise their right of suffrage as if they were present at the usual places of election. This act was substantially reënacted in a general election law passed July 2, 1839. The subject of permitting the volunteers absent to vote was made a question before the Supreme Court of the State, which decided that, by reason of a phrase in the constitutional amendments adopted in 1838, such proceeding had become unconstitutional.

The number of banks in the State is about 90, and their circulation, at the close of the year, was \$22,500,000; specie, \$11,500,000. There are 12 savings banks, and 86 insurance companies, chiefly of New York, doing business in the State.

The length of the railroads of the State is 3,050 miles, cost \$155,472,278. In the cities of the State there are 176 miles of city pas-

senger railroads, costing \$4,446,877. There are 10 colleges in the state, and 15 theological seminaries, 5 medical, and 1 law, besides numerous educational institutions of a high order. The common school system was adopted in 1834, and has made rapid progress. There are also 12 Normal school districts, in which provision has been made for the establishment of a school. In Philadelphia the schools are unsurpassed by those of any other city.

The charitable institutions of the State are on a scale of the first magnitude.

In mineral wealth Pennsylvania is unsurpassed by any other State on the Atlantic coast. To these treasures is now to be added an immense product of petroleum, of which the flow in one region—that of Oil Creek—is estimated at 75,000 barrels monthly.

The Lehigh valley region of the State was visited in autumn by a most destructive freshet which swept everything before it.

**PRESBYTERIANS.** In 1861, at the beginning of the civil war, there were the following Presbyterian denominations in the United States: 1. Old School Presbyterian Church, with 176 presbyteries, 2,767 ministers, 800,874 members (in 1862, 803,289); 2. New School Presbyterian Church, with 105 presbyteries, 1,558 ministers, 184,760 members (in 1862, 185,454); 3. The Cumberland Presbyterian Church, with 97 presbyteries, 1,150 ministers, and about 103,000 communicants; 4. The United Presbyterian Church of North America, with 43 presbyteries, 444 ministers, and 57,567 members; 5. United Synod of the Presbyterian Church, with 81 Presbyteries, 411 ministers, 50,295 communicants; 6. Reformed Presbyterian Church (General Synod), with 7 presbyteries, 56 ministers, about 70,000 members; 7. Reformed Presbyterian Church (Synod), with 9 presbyteries, 59 ministers, 6,650 communicants; 8. Associate Reformed Synod of the South, with 75 ministers, 9,500 members; 9. Associate Synod of North America, with 49 ministers, and 1,180 members; 10. Associated Reformed Synod of New York, with 14 ministers, 1,631 members; 11. Free Presbyterian Synod of the U. S., with 41 ministers, about 4,000 members; 12. The Independent Presbyterian Church (in South and North Carolina), with 4 ministers and about 1,000 communicants.

Of all these twelve organizations, only two, the Old School Presbyterians and the Cumberland Presbyterians, had a numerous membership, both in the free and in the slave States. The former was rent in consequence of the General Assembly, in 1861, passing resolutions, moved by Rev. Dr. Spring, and expressive of loyalty to the Constitution of the United States, and of the obligation to promote the integrity of the United States. The churches of the seceded States declared at once in favor of forming an independent church organization. In December, 1861, a convention of delegates from the Southern presbyteries met

at Augusta, Georgia, to adopt a constitution, and take other measures necessary for the establishment of a separate church. It was determined that the title of the new body should be, "The General Assembly of the Presbyterian Church in the Confederate States of America," and that "the Standing Committees" (in lieu of the former church "boards") should be located at Columbia, S. C., New Orleans, Memphis, and Richmond. The convention also adopted an address (drawn up by Dr. Thornwell) to the Church of Christ throughout the world, on the reasons of their separate organization. The first general assembly of the church was held in Montgomery, Ala., in May, 1862, and was attended by only 31 ministers and 16 ruling elders. The committee of foreign missions had received \$14,946; that of domestic missions \$8,984. The committee on the state of religion stated that not a few congregations had been entirely disbanded.

The Cumberland Presbyterian Church was not formally dissolved by the war, though it was actually dismembered. Those church boards which were located in Tennessee, and under the control of men sympathizing with secession, were broken up. As, however, many Cumberland Presbyterians in the seceded States, especially in East Tennessee, were supposed to be loyal to the United States, and equally opposed to secession from the church, it was hoped that, in the case of a restoration of the Union, the unity of the church would also be preserved. The General Assembly of the church met at Owensboro', Ky., and was attended by about 60 commissioners. The assembly declined to pass any Union resolutions, in order to give no offence to any political party, and, in the hope of seeing a reunion of the church, did not appoint any new church boards, but preferred to leave, for one year, the wants of the church unprovided.

The Old School Presbyterian General Assembly met, in 1861, at Columbus, Ohio, and elected Rev. Dr. Beatty, of Steubenville, Ohio, moderator. A series of declarations were submitted by Rev. Dr. Breckenridge, of Danville Theological Seminary, severely denouncing secession, and enjoining the necessity of upholding the Federal and State Governments, and all persons in authority, in all their lawful and proper acts for the suppression of the insurrection. After a long and animated debate, the declarations were adopted by a vote of 199 ayes against 20 noes. The meetings of the synods and presbyteries which were held during the year gave, almost unanimously, an emphatical endorsement to the Spring resolutions of 1861, and the Breckenridge declarations of 1862. Many synods also passed strong anti-slavery resolutions. The opinion in the border States was divided. The Synod of Baltimore expressed a cordial approbation of the Breckenridge declarations, while in the Synod of Kentucky, a considerable party, headed by Dr.

Robinson, of Louisville, the editor of the "True Presbyterian," denounced these declarations as a perversion of the true Presbyterian doctrine of the relation between church and state. The paper of Dr. Robinson was, in the course of the year, suppressed by the military authorities, on the charge of disloyalty. That party of the Kentucky Presbyterians which agreed with the majority of the General Assembly of 1862 had an able organ in the quarterly "Danville Review."

The New School General Assembly met at Cincinnati, and elected Rev. Dr. George Duffield, of Detroit, moderator. It was attended by 104 ministers and 86 elders. Strong Union and anti-slavery resolutions were presented by the special committee on the state of the country, through Rev. Dr. Beman, of Troy, and were passed by a vote entirely unanimous. They denounced, in strong terms, the instigators of secession, all who sympathized with it, those in the North who fail to support vigorously the Federal Government, and expressed the opinion that this whole insurrectionary movement could be traced to one primordial root, and one only—African slavery, the love of it and determination to make it perpetual. The New School General Assembly has some churches in Missouri, Delaware, and the District of Columbia, all of which fully approve of the anti-slavery position of the church.

The secession of most of the Southern churches of the Old School Presbyterian Church, and the growth of anti-slavery sentiment in the northern part of the church, suggested the plan of a reunion of the Old and New School Presbyterian Churches in the Federal States. On Jan. 14 the Old School presbytery of Ogdensburgh, and the New School presbytery of St. Lawrence, both of which met at Ogdensburgh, N. Y., held a joint meeting, and unanimously passed a resolution expressive of their desire to be united in one presbytery, one synod, and one general assembly. The plan of a union was strongly advocated by the Philadelphia "Standard" and Cincinnati "Presbyter" of the Old School, and the "American Presbyterian" of the New School Presbyterian Church, and petitions were sent to both the general assemblies for that end. The New School General Assembly passed, with regard to this subject, the following resolution: "That it would give us pleasure to unite in closest fellowship with all persons who can stand with us upon the basis of our confession of faith and book of discipline, and who substantially agree with us on the great moral questions of the day, especially in the matter of loyalty to the Government, and in the views of slavery set forth prior to the division in 1836." The Old School General Assembly, which had been addressed in favor of the subject by four presbyteries, showed itself less favorable to this plan, and passed a resolution declaring it inexpedient to take action upon the subject at present.

In the seceded States the plan of a union between the United Synod, which originated several years ago by separation from the New School General Assembly on account of the latter having passed anti-slavery resolutions, and the newly seceded Old School Presbyterian Synod of the South, was likewise proposed on the part of the United Synod, and advocated by the "Christian Observer," which, after the beginning of the war, had been transferred from Philadelphia to Richmond, and Dr. Boyd, of Winchester, one of the leading men of the church. It was, however, received with little favor by the Old School Presbyterians, who declared their determination to stand by the act of the General Assembly of 1836, by which the New School party was excinded. The plan of a union was, consequently, dismissed.

The United Synod suffered, probably, more from the war than any other body of Presbyterians. A considerable portion of its territory was, for a shorter or longer period, in the possession of Union troops, and, while the majority of the church, like nearly all the other religious denominations, strongly favored the cause of secession, some leading men, as Mr. Maynard, member of the United States Congress from East Tennessee, were strongly in favor of the Union.

The General Assembly of the United Presbyterian Church convened at Pittsburg on May 21, and elected Rev. Dr. Cooper, of Philadelphia, moderator. Strong anti-slavery resolutions were unanimously passed, and it was resolved to memorialize Congress, conjointly with the Reformed Presbyterian Church, in favor of emancipation. It was also resolved to establish missions in the South, and a committee was appointed to designate the points to which missionaries were to be sent.

The Reformed Presbyterians, who are split into two parties, generally denominated the General Synod, and the Synod of Reformed Presbyterians, are among the most determined anti-slavery churches in this country. The latter branch still refrains from acknowledging the Constitution of the United States, on the ground that it tolerates slavery. The former branch, the General Synod, has one solitary congregation in the slaveholding States—at Fayetteville, Tenn. After the beginning of the war, great efforts were made to induce the members of this congregation to sign an oath of allegiance to the Confederate Government, but all refused. Subsequently, the congregation has suffered a great deal of persecution, and most of its members have been obliged to flee to the free States. The annual assemblies of both bodies passed resolutions expressive of their conviction "that, so long as slavery lives, no permanent peace can be enjoyed," and warning the nation "that a compromise with slavery would be no less dangerous to the stability of our Government than to the cause of human freedom."

A portion of the Free Presbyterian Synod,

which, some years ago, originated by separation from the New School Presbyterian General Assembly, because the stand taken by the latter body against slavery appeared to them to be not sufficiently decided, has reunited during the year with the New School Presbyterian Church, which, it is believed, will soon absorb the entire Free Synod.

The Presbyterian churches in the British Provinces of North America had been reduced, at the end of 1861, by the union of the branches of the Free and the United Presbyterian bodies to six, viz: 1. The Canada Presbyterian Church, with 14 presbyteries, 336 churches, 34,000 communicants; 2. Church of Scotland in Canada, with 9 presbyteries, 126 churches, 18,500 communicants; 3. Church of the Lower Provinces, with 9 presbyteries, 95 churches, 9,617 communicants; 4. Church of Scotland in Nova Scotia and Prince Edward's Island, 3 presbyteries, 26 churches, 2,100 communicants; 5. Church of New Brunswick, 3 presbyteries, 27 churches, 1,600 communicants; 6. Church of Scotland in New Brunswick, with 3 presbyteries, 16 churches, 1,500 communicants. At their assemblies, held in 1861, the Canada Presbyterian Church, the Church of the Lower Provinces, and the Church of New Brunswick, had under deliberation the project of uniting into one organization the Presbyterian Church of the British Provinces, and even the three branches of the Church of Scotland in Canada, New Brunswick, and the lower provinces (Nova Scotia and Prince Edward's Island), did not declare themselves altogether opposed to a union of all the Presbyterian bodies, although they refused to join it for the present.

In Europe, Presbyterianism is mainly restricted to the British Isles. The reformed churches of the continent of Europe, however—though designated by a different name—are substantially the same. The chief seat is Scotland, where one of the Presbyterian organizations, the Church of Scotland, is the recognized state church, whose General Assembly is every year opened, in the name of the Government, by a lord high commissioner, and which accepts its status and emoluments from the state. The other churches considerably differ in their relation to the state. The Free Church would accept the aid of the state on condition that the church should be left perfectly free and self-regulative. The Reformed Presbyterians would not accept an alliance with the state unless the character of the state was wholly Christian, and the church left perfectly free. The United Presbyterians would not accept an alliance with the state on any terms, believing such an alliance to be wrong and mischievous.

The General Assembly of the Established Church of Scotland met at Edinburgh on May 22, and elected Dr. Bisset Bourtrie, moderator. The church has 16 synods, 84 presbyteries, and 1,204 congregations. The Lay Association, in

support of the schemes of the church, reported an income of £1,181; the committee for colonial missions £3,000; the committee on Jewish missions £3,961.

The Free Church General Assembly met likewise at Edinburgh on May 22, and elected Dr. Guthrie moderator. The church has 16 synods, 71 presbyteries, 843 churches, 8 colleges for the education of theological students. The funds raised during the year were as follows:—sustentation of ministers, £112,887; building fund, £38,518; congregational fund, £105,341; missions and education, £59,815; total, £337,204.

The United Presbyterian Church, composed of a union, constituted in 1847, of the Secession (formed in 1732) and Relief (originated in 1752) Churches, commenced its General Assembly at Edinburgh on May 5. The returns from congregations showed a membership of 167,558, and an aggregate amount of £205,167 collected for congregational, missionary, and benevolent purposes. The church has 31 presbyteries in England and Scotland, 540 ministers, 1 theological hall at Edinburgh.

The Reformed Presbyterian Synod, which originated in 1706 (also called Cameronians or Covenanters), held its annual meeting in Glasgow. The synod was chiefly occupied with the question, which for some years has been agitating the Reformed Presbyterian Church, whether discipline should be exercised against members who, contrary to the testimony of the church against the evils of the British Constitution, had taken the oath of allegiance or exercised elective franchise. The synod formally resolved, by a majority of 42 to 11, that, as the construction of the oath of allegiance hitherto generally accepted is now called in question by many in the church, "and having regard to the apostolical injunction, that no matter of doubtful disputation should be made the ground of church censure, the synod, while they abstain from any judicial censure of the opinions given in, feel that they have no warrant to visit members taking the oath in this sense, or exercising the franchise, with the infliction of ecclesiastical penalties, or suspension or expulsion from the church." The Reformed Presbyterian Church had, in 1862, 6 presbyteries, 44 churches, and 36 ministers.

The Synod of United Original Seceders was dissolved in 1852 and united to the Free Church. 25 congregations, however, refused to join that church, and still continue a separated body, divided into 4 presbyteries.

The Presbyterian Church in England, which was instituted in 1836, has now 7 presbyteries and 105 churches. A movement has been begun for a union between this body and the United Presbyterian congregations of England.

The Presbyterian Church of Ireland had, in 1861, 37 presbyteries, 530 churches, 57,000 communicants; the Reformed Presbyterian Church in Ireland, 9 presbyteries, 55 churches, 4,000 communicants.

As it is but fair those longest in captivity should be released first, I request you will let the privateersmen be released, and I will reciprocate, and release those longest confined.

I have requested Gen. Winder to send prisoners from Richmond to Newport News on Monday, the 5th inst.

Very respectfully, your obedient servant,  
**BENJ. HUGER, Maj.-Gen. Commanding.**  
 Maj.-Gen. J. E. Wool,  
 Commanding Department of Virginia.

On the 19th, Gen. Wool wrote that he was prepared to make exchange on the terms proposed by Gen. Huger in the above communication, adding, "I will have the privateersmen sent to this post (Fortress Monroe), to be forwarded to you at any place you designate on James river, provided you will send forward, at the same time, the hostages, Cols. Corcoran, Wilcox," &c.; and, on the succeeding day, Gen. Huger replied from Petersburg:

If you will release upon parole the privateersmen, and send them to me at City Point, I will return you such number of your officers, heretofore retained as hostages for them, as would be their equivalent, according to the rates of exchange prescribed by the cartel between the United States and Great Britain in 1813—the captains of privateersmen to rank as lieutenants of the navy, and the mates of the privateers as master's mates. If you will have the rank and number of the privateersmen made out, and their equivalent of officers now retained as hostages for them, such officers will be released unconditionally and returned to you. Any of the other hostages that may not be required for exchange for the privateersmen will be released upon parole, to be exchanged for officers of equal rank, or their equivalent, according to the cartel above alluded to.

On the 21st, Gen. Wool despatched another letter to Gen. Huger, requesting him to appoint a time for the exchanges to take place, and received the following reply:

HEADQUARTERS, DEPARTMENT OF APPOMATTOX, }  
 PETERSBURG, VA., May 23, 1862. }

GENERAL: I have detained your boat until to-day, expecting an answer from Richmond as to the time when the prisoners to be exchanged for the privateersmen could reach here. I have not yet received an answer, and I am not aware of the location of these officers, or when they could reach here; but I can assure you I consider the War Department have fully agreed to the terms stated in my letter of the 3d instant to you, and which have been accepted by yourself. I must be responsible that on the delivery of all the privateersmen all the officers retained as hostages will be released upon parole, the details of the exchanges to be arranged between us according to the cartel referred to, and such of the officers as are not exchanged in this way to remain on parole until exchanged for others. If not interrupted by movements in the field, I will promise to have the officers forwarded as soon as possible, and will send notice to any of your vessels, and request you may be notified to send for them.

Very respectfully, your obedient servant,  
**BENJ. HUGER, Maj.-Gen. Commanding.**

Supposing the matter to be definitely settled, Gen. Wool, on June 1, sent the privateersmen, 85 in number, to City Point, on the James river, with instructions to deliver them up on receiving the hostages on parole. The latter not being on the spot, the privateersmen were withheld, and a communication was sent to the Confederate authorities demanding an explanation. An answer came back that Gen. Huger

had exceeded his authority, and that further conference would be necessary before the exchange could be effected. With a view to the holding of such a conference, the flag of truce boat remained at the Point until the 6th, when, learning that nothing further was expected from Richmond, she returned to Fortress Monroe.

The following letter from the Confederate Secretary of War, of which a copy was transmitted by Gen. Huger to Gen. Wool, gives his reasons for refusing to abide by Gen. Huger's communication of May 23:

C. S. A. WAR DEPARTMENT, RICHMOND, June 8, 1862.

GENERAL: I have received your letter of the 23th ultimo, in which you give a construction in your agreement with Gen. Wool for the exchange of the privateersmen and the persons formerly held as hostages, which requires us to return *all* of the latter for all of the former, and to parole such of the so-called hostages as are not exchanged, and to support this construction you refer me to your letter of May 23 to Gen. Wool.

Upon examining that letter I find that you use the following language: "I must be responsible that on the delivery of *all* the privateersmen all the officers detained as hostages will be released upon parole." If this were the agreement, there could be no doubt of your promise to return all the "officers retained as hostages;" but in the same letter you state that the agreement was contained in your letter of May 3, and you say, "I consider the War Department has fully agreed to the terms stated in my letter of the 3d inst."

The letter of May 3, so far from promising "to return all the officers, as hostages," as you apparently suppose, confines the proposed exchange to such as Gen. Wool might name, and as would be equivalent to the privateersmen according to the tariff agreed upon by the cartel between Great Britain and the United States in 1813, and consents that when that exchange had been made the other officers held as hostages might be exchanged "as usual." There can be no doubt about the agreement; your language is perfectly explicit. You say to Gen. Wool, "I will return such officers as you may name in exchange according to the tariff agreed upon by the cartel between Great Britain and the United States in 1813. As soon as these men are exchanged, any other officers that have been held as hostages will be exchanged as usual."

I am willing to perform the agreement which you stated to Gen. Wool that the department had fully agreed to perform, but I cannot consent to carry out a palpable misconstruction of it, much more disadvantageous to the Government of the Confederate States than the agreement itself, and evidently the result of mere inadvertence on your part. Even this erroneous interpretation of your promise is founded on the supposition that "officers were still retained as hostages," when, in fact, they had all been restored to the condition of prisoners of war, and a colonel and three captains were actually then on parole. It is therefore not only erroneous in its construction of the agreement actually made, but is founded upon such a misconception of facts that it would not bind you as an independent agreement.

You will, therefore, inform Gen. Wool that the War Department will execute faithfully your agreement with him of May 3, without considering whether you were authorized to make it or not; that we will exchange such officers recently held as hostages as he may name for the privateersmen, according to the cartel agreed on, but that we shall hold others to be exchanged hereafter.

I might justly complain that Gen. Wool, after being informed by Gen. Cobb that the "officers hitherto held as hostages for the privateersmen had been placed on the same footing as other prisoners of war," and knowing that a number of them, more than equivalent to the

privateersmen, had actually been paroled, should yet negotiate with you as if they were all still held as hostages, apparently taking advantage of the circumstance that you were not so well informed as himself.

Very respectfully, your obedient servant,

G. W. RANDOLPH, Secretary of War.

Major-General B. HUGER,  
Commanding Department of the Appomattox.

Accompanying this letter was the following personal explanation of Gen. Huger:

HEADQUARTERS HUGER'S DIVISION, June 5, 1862.

SIR: I enclose you a copy of a letter I received from the War Department. I have heard from private persons that the privateersmen whom you promised to send for exchange had arrived at City Point, but no letter to me has as yet been forwarded. As I had charge of the correspondence with yourself on the subject, I hasten to send you this communication, which I must confess I do not clearly understand. The language of one of my letters may not have been the same as another; but I did intend not to give you all the officers once retained as hostages in exchange for all the privateersmen, but to give you such numbers of them in exchange as would be required by the cartel exchanging the equivalent of rank, and the other officers to be exchanged as usual. As you agreed to these terms, and had a sufficient number of our officers, there was no reason why the exchange should not be made at once; and I shall insist, if the privateers have been sent, as I hear, that all the officers referred to above be given in exchange. I think it but fair we should name the officers to be exchanged on our side; and as the most equitable way, I propose to exchange those who have been longest prisoners, including navy officers.

I am, General,

Very respectfully, your obedient servant,

BENJ. HUGER,

Major-General Commanding.

Major-Gen. JOHN E. WOOL,  
or Officer Commanding Department of Virginia.

Here the matter rested, and for upward of a month nothing seems to have been done toward a general exchange, notwithstanding in the mean time prisoners had accumulated in large numbers on either side. The Confederates had indeed made certain overtures, by sending to Washington Col. Miller and Major Stone, who had been captured in the battle near Pittsburg Landing, to induce the National Government to adopt some general plan. This the latter declined to do, claiming that certain Confederate officers of rank, as Gen. Buckner, captured at Fort Donelson, had, in consequence of acts done previous to the war, forfeited their right to be considered prisoners of war, and ought to be excepted from any cartel entered into by the belligerents, and to be held amenable for treason. The Confederates, on the other hand, insisted that the rule should be general, although from the reluctance which they had manifested in releasing Col. Corcoran and other prisoners demanded by the people of the Northern States, it was evident that they had been themselves inclined to make exceptions.

In obedience to a very general popular demand the National Government finally decided to yield its point, and on July 17, Gen. Dix, who had meanwhile succeeded Gen. Wool in command at Fortress Monroe, met the Confederate general D. H. Hill, in conference, at Turkey Island Creek on the James river, where on the 22d was signed the following agreement

for the exchange of prisoners, based upon the cartel of 1812 between the United States and Great Britain, and which was claimed by the Richmond papers to mark an important era in the war, by acknowledging the quasi nationality of the Confederate Government:

HAXALL'S LANDING, ON JAMES RIVER, VA. }  
July 22, 1862. }

The undersigned, having been commissioned by the authorities they respectively represent to make arrangements for a general exchange of prisoners of war, have agreed to the following articles:

ARTICLE 1.—It is hereby agreed and stipulated that all prisoners of war held by either party, including those taken on private armed vessels, known as privateers, shall be discharged upon the conditions and terms following:

Prisoners to be exchanged man for man and officer for officer; privates to be placed on the footing of officers and men of the navy.

Men and officers of lower grades may be exchanged for officers of a higher grade, and men and officers of different services may be exchanged according to the following scale of equivalents:

A general commander-in-chief or an admiral shall be exchanged for officers of equal rank, or forty-six privates or common seamen.

A flag officer or major-general shall be exchanged for officers of equal rank, or for forty privates or common seamen.

A commodore carrying a broad pennant, or a brigadier-general, shall be exchanged for officers of equal rank, or twenty privates or common seamen.

A captain in the navy, or a colonel, shall be exchanged for officers of equal rank, or for fifteen privates or common seamen.

A lieutenant-colonel, or a commander in the navy, shall be exchanged for officers of equal rank, or for ten privates or common seamen.

A lieutenant commander or a major shall be exchanged for officers of equal rank, or eight privates or common seamen.

A lieutenant or a master in the navy, or a captain in the army or marines, shall be exchanged for officers of equal rank, or six privates or common seamen.

Masters' mates in the navy, or lieutenants and ensigns in the army, shall be exchanged for officers of equal rank, or four privates or common seamen.

Midshipmen, warrant officers in the navy, masters of merchant vessels, and commanders of privateers, shall be exchanged for officers of equal rank, or three privates or common seamen: second captains, lieutenants, or mates of merchant vessels or privateers, and all petty officers in the navy and all non-commissioned officers in the army or marines, shall be severally exchanged for persons of equal rank, or for two privates or common seamen; and private soldiers and common seamen shall be exchanged for each other, man for man.

ART. 2.—Local, State, civil, and militia rank held by persons not in actual military service will not be recognized, the basis of exchange being of a grade actually held in the naval and military service of the respective parties.

ART. 3.—If citizens held by either party on charge of disloyalty or any alleged civil offence are exchanged, it shall only be for citizens, captured sutlers, teamsters, and all civilians in the actual service of either party, to be exchanged for persons in similar position.

ART. 4.—All prisoners of war to be discharged on parole in ten days after their capture, and the prisoners now held and those hereafter taken to be transported to the points mutually agreed upon at the expense of the capturing party. The surplus prisoners not exchanged shall not be permitted to take up arms again, nor to serve as military police or constabulary force in any fort, garrison, or field work held by either of the respective parties, nor as guards of prisoners, depots, or stores, nor to discharge any duty usually performed by

soldiers, until exchanged under the provisions of this cartel. The exchange is not to be considered complete until the officer or soldier exchanged for has been actually restored to the lines to which he belongs.

ART. 5.—Each party, upon the discharge of prisoners of the other party, is authorized to discharge an equal number of their own officers or men from parole, furnishing at the same time to the other party a list of their prisoners discharged and of their own officers and men relieved from parole, enabling each party to relieve from parole such of their own officers and men as the party may choose. The lists thus mutually furnished will keep both parties advised of the true condition of the exchanges of prisoners.

ART. 6.—The stipulations and provisions above mentioned to be of binding obligation during the continuance of the war, it matters not which party may have the surplus of prisoners, the great principle involved being:

1. An equitable exchange of prisoners, man for man, officer for officer, or officers of higher grade exchanged for officers of lower grade or for privates, according to the scale of equivalents.

2. That privates and officers and men of different services may be exchanged according to the same rule of equivalents.

3. That all prisoners, of whatsoever arm of service, are to be exchanged or paroled in ten days from the time of their capture, if it be practicable to transfer them to their own lines in that time; if not, as soon thereafter as practicable.

4. That no officer, soldier, or employé in the service of either party is to be considered as exchanged and absolved from his parole until his equivalent has actually reached the line of his friends.

5. That the parole forbids the performance of field, garrison, police, or guard or constabulary duty.

JOHN A. DIX, Major-General.

D. H. HILL, Major-General, C. S. Army.

#### Supplementary Articles.

ART. 7.—All prisoners of war now held on either side, and all prisoners hereafter taken, shall be sent with all reasonable despatch to A. H. Aikens, below Dutch Gap, on the James river, in Virginia, or to Vicksburg, on the Mississippi river, in the State of Mississippi, and there exchanged, or paroled until such exchange can be effected, notice being previously given by each party of the number of prisoners it will send, and the time when they will be delivered at those points respectively; and in case the vicissitudes of war shall change the military relations of the places designated in this article to the contending parties, so as to render the same inconvenient for the delivery and exchange of prisoners, other places, bearing as nearly as may be the present local relations of said places to the lines of said parties, shall be, by mutual agreement, substituted. But nothing in this article contained shall prevent the commanders of two opposing armies from exchanging prisoners or releasing them on parole at other points mutually agreed on by said commanders.

ART. 8.—For the purpose of carrying into effect the foregoing articles of agreement, each party will appoint two agents, to be called Agents for the Exchange of Prisoners of War, whose duty it shall be to communicate with each other by correspondence and otherwise, to prepare the list of prisoners, to attend to the delivery of the prisoners at the places agreed on, and to carry out promptly, effectually, and in good faith, all the details and provisions of the said articles of agreement.

ART. 9.—And in case any misunderstanding shall arise in regard to any clause or stipulation in the foregoing articles, it is mutually agreed that such misunderstanding shall not interrupt the release of prisoners on parole, as herein provided, but shall be made the subject of friendly explanations, in order that the object of this agreement may neither be defeated nor postponed.

JOHN A. DIX, Major-General.

D. H. HILL, Major-General C. S. A.

Acting in the humane spirit which charac-

terized this agreement, the adjutant-general of the United States a few days afterward issued an order that chaplains should not be held as prisoners of war, and directing the immediate and unconditional release of all chaplains so held.

In accordance with the terms of the cartel, an exchange of prisoners commenced forthwith, and by the middle of August most of the officers of rank on either side, who had been for any lengthened period in captivity, were released. So far as the case of prisoners of this class was concerned, matters worked harmoniously enough; but new complications, the result of circumstances happening subsequent to the cartel, soon occurred, which gave rise to an acrimonious correspondence between the belligerent parties, and a series of retaliatory orders from the Confederate authorities.

Previous to the adoption of the cartel of July 22, however, the Confederate general, R. E. Lee, had written to the authorities at Washington, under date of July 6, requesting information respecting the alleged execution by the national authorities of John Owens and William B. Mumford, citizens of the seceded States, and on certain other points, indicated in the following reply of Gen. Halleck, the general-in-chief of the United States army:

HEADQUARTERS OF THE ARMY, WASHINGTON, }  
Aug. 7, 1862. }

Gen. R. E. Lee, Commanding, &c. :

GENERAL: Your letter of July 6 was received at the Adjutant-General's office on the 14th, but supposing from the endorsement that it required no further reply, it was filed without being shown to the President or Secretary of War. I learned to day, for the first time, that such letter had been received, and hasten to reply.

No authentic information has been received in relation to the execution of either John Owens or Mumford, but measures will be immediately taken to ascertain the facts of these alleged executions, of which you will be duly informed.

I need hardly assure you, general, that, so far as the United States authorities are concerned, this contest will be carried on in strict accordance with the laws and usages of modern warfare, and that all excesses will be duly punished.

In regard to the burning of bridges, &c., within our lines by persons in disguise as peaceful citizens, I refer you to my letter of the 22d of January last to Gen. Price.\* I think you will find the views there expressed as most materially differing from those stated in your letter.

In regard to retaliation, by taking the lives of innocent persons, I know of no modern authority which justifies it except in the extreme case of a war with any uncivilized foe, which has himself first established such a barbarous rule. The United States will never countenance such a proceeding unless forced to do so by the barbarous conduct of an enemy who first applies such a rule to our own citizens.

Very respectfully, your obedient servant,

H. W. HALLECK,

General-in-Chief of U. S. Army.

\* In this letter Gen. Halleck, then commanding the department of Missouri, reiterated his intention to subject persons, other than soldiers, accused of burning or destroying railroads, bridges, and similar property, to trial by court-martial, notwithstanding such persons had been authorized and instructed by Gen. Price to commit such acts. Armed men, in the garb of soldiers, destroying bridges as a military act, would, if captured, be treated as ordinary prisoners of war.

On July 31, Gen. Lee addressed a communication to Gen. McClellan, then in command at Harrison's Landing, stating that he was informed that many Confederate citizens, engaged in peaceful vocations, had been arrested and imprisoned because they refused to take the oath of allegiance to the United States; while others, by harsh treatment, had been compelled to take an oath not to bear arms against the National Government; adding:

This Government refuses to admit the right of the authorities of the United States to arrest our citizens, and extort from them their parole not to render military service to their country under the penalty of incurring punishment in case they fall into the hands of your forces.

I am directed by the Secretary of War to inform you that such oaths will not be regarded as obligatory, and persons who take them will be required to render military service. Should your Government treat the rendition of such service by these persons as a breach of parole, and punish it accordingly, this Government will resort to retaliatory measures as the only means of compelling the observance of the rules of civilized warfare.

The matter was referred by Gen. McClellan to Gen. Halleck, who in reply to that officer, dated August 13, made the following statement of the policy which the Government would pursue:

The Government of the United States has never authorized any extortion of oaths of allegiance or military paroles, and has forbidden any measures to be resorted to tending to that end. Instead of extorting oaths of allegiance and paroles, it has refused the applications of several thousand prisoners to be permitted to take them and return to their homes in the rebel States.

At the same time this Government claims and will exercise the right to arrest, imprison, or place beyond its military lines any persons suspected of giving aid and information to its enemies, or of any other treasonable act. And if persons so arrested voluntarily take the oath of allegiance, or give their military parole, and afterward violate their plighted faith, they will be punished according to the laws and usages of war.

You will assure Gen. Lee that no unseemly threats of retaliation on his part will deter this Government from exercising its lawful rights over both persons and property, of whatsoever name or character.

On July 22 an important order was issued by Secretary Stanton, acting under instructions from the President, by which military commanders in Virginia and other parts of the seceded States were empowered "in an orderly manner to seize and use any property, real or personal, which may be necessary or convenient for their several commands, for supplies or for other military purpose;" to employ at reasonable wages persons of African descent when needed; and requiring that "as to both property and persons of African descent, accounts shall be kept sufficiently accurate and in detail, to show quantities and amounts, and from whom both property and such persons shall have come, as a basis upon which compensation can be made in proper cases." In accordance with the terms of this document Gen. Pope, then recently appointed to the command of the army of Virginia, directed his division

generals to seize all horses and mules in their vicinity, and all stores not absolutely needed by the inhabitants for their maintenance or subsistence; and his General Order No. 11, dated July 23, required all officers of his army holding independent commands to arrest all disloyal male citizens within their lines or within their reach. "Such as are willing to take the oath of allegiance to the United States," &c., the order continued. (*See ARMY OPERATIONS.*)

These several orders did not fail to create excitement among the Confederate authorities at Richmond, and ultimately led to the retaliatory action suggested by the two following documents, of which the first was addressed by President Davis to Gen. Lee:

RICHMOND (VA.), July 31, 1862.

SIR: On the 22d of this month a cartel for the general exchange of prisoners of war was signed between Maj.-Gen. D. H. Hill, in behalf of the Confederate States, and Maj.-Gen. John E. Dix, in behalf of the United States. By the terms of this cartel it is stipulated that all prisoners of war hereafter taken shall be discharged on parole till exchanged.

Scarcely had that cartel been signed when the military authorities of the United States commenced a practice changing the whole character of the war from such as becomes civilized nations into a campaign of indiscriminate robbery and murder.

The general order issued by the Secretary of War of the United States, in the city of Washington, on the very day the cartel was signed in Virginia, directs the military commanders of the United States to take the private property of our people for the convenience and use of their armies, without compensation.

The general order issued by Maj.-Gen. Pope on the 23d day of July, the day after the signing of the cartel, directs the murder of our peaceful inhabitants as spies, if found quietly tilling the farms in his rear, even outside of his lines; and one of his brigadier-generals, Steinwehr, has seized upon innocent and peaceful inhabitants to be held as hostages, to the end that they may be murdered in cold blood, if any of his soldiers are killed by some unknown persons whom he designates as "bushwhackers."

Under this state of facts, this Government has issued the enclosed general order, recognizing Gen. Pope and his commissioned officers to be in the position which they have chosen for themselves—that of robbers and murderers, and not that of public enemies, entitled, if captured, to be considered as prisoners of war.

We find ourselves driven by our enemies by steady progress toward a practice which we abhor and which we are vainly struggling to avoid.

Some of the military authorities of the United States seem to suppose that better success will attend a savage war in which no quarter is to be given, and no age or sex to be spared, than has hitherto been secured by such hostilities as are alone recognized to be lawful by civilized men in modern times.

For the present we renounce our right of retaliation on the innocent, and shall continue to treat the private enlisted soldiers of Gen. Pope's army as prisoners of war; but if, after the notice to the Government at Washington of our confining repressive measures to the punishment only of the commissioned officers who are willing participants in these crimes, these savage practices are continued, we shall be reluctantly forced to the last resort of accepting the war on the terms observed by our foes, until the outraged voice of common humanity forces a respect for the recognized rules of war.

While these facts would justify our refusal to execute the generous cartel by which we have consented to



liberate an excess of thousands of prisoners held by us beyond the number held by the enemy, a sacred regard to plighted faith, shrinking from the mere semblance of breaking a promise, prevents our resort to this extremity.

Nor do we desire to extend to any other forces of the enemy the punishment merited alone by Gen. Pope and the commissioned officers who choose to participate in the execution of his infamous orders.

You are hereby instructed to communicate to the commander-in-chief of the United States the contents of this letter, and a copy of the enclosed general order, to the end that he may be notified of our intention not to consider the officers hereafter captured from Gen. Pope's army as prisoners of war.

Very respectfully yours, &c.,

JEFFERSON DAVIS.

To Gen. R. E. LEE, Commanding.

The substance of this letter was communicated by Gen. Lee, according to President Davis's request, to Gen. Halleck on Aug. 2, with the accompanying General Order No. 54:

*Confederate General Order No. 54.*

ADJUTANT AND INSPECTOR-GENERAL'S OFFICE, }  
RICHMOND, August 1, 1862. }

*First.* The following orders are published for the information and observance of all concerned.

*Second.* Whereas, by a general order dated the 22d of July, 1862, issued by the Secretary of War of the United States, under the order of the President of the United States, the military commanders of that Government within the States of Virginia, South Carolina, Georgia, Florida, Alabama, Mississippi, Louisiana, Texas and Arkansas, are directed to seize and use any property, real or personal, belonging to the inhabitants of this Confederacy, which may be necessary or convenient for their several commands, and no provision is made for any compensation to the owners of private property thus seized and appropriated by the military commands of the enemy.

*Third.* And whereas, by General Order No. 11, issued by Major-General Pope, commanding the forces of the enemy in Northern Virginia, it is ordered that all commanders of any army corps, divisions, brigades, and detached commands, will proceed immediately to arrest all disloyal male citizens within their lines or within their reach in the rear of their respective commands. Such as are willing to take the oath of allegiance to the United States, and shall furnish sufficient security for its observance, will be permitted to remain in their houses, and pursue in good faith their accustomed avocations; those who refuse shall be conducted south beyond the extreme pickets of the army, and be notified if found again anywhere within our lines, or at any place in the rear, they will be considered spies and subjected to the extreme rigor of military law. If any person, having taken the oath of allegiance as above specified, be found to have violated it, he shall be shot, and his property seized and applied to the public use.

*Fourth.* And whereas, by an order issued on the 18th of July, 1862, by Brigadier-General A. Steinwehr, Major William Steadman, a cavalry officer of his brigade, has been ordered to arrest five of the most prominent citizens of Page county, Virginia, to be held as hostages, and to suffer death in the event of any of the soldiers of said Steinwehr being shot by bushwhackers, by which term are meant the citizens of this Confederacy who have taken up arms to defend their lives and families.

*Fifth.* And whereas it results from the above orders that some of the military authorities of the United States, not content with the unjust and aggressive warfare hitherto waged with savage cruelty against an offending people, and exasperated by the failure of their efforts to subjugate them, have now determined to violate all the rules and usages of war, and to convert the hostilities, hitherto waged against armed forces,

into a campaign of robbery and murder against innocent citizens and peaceful tillers of the soil.

*Sixth.* And whereas this Government, bound by the highest obligations of duty to its citizens, is thus driven to the necessity of adopting such just measures of retribution and retaliation as shall seem adequate to repress and punish these barbarities. And whereas the orders above recited have only been published and made known to this Government since the signature of a cartel for the exchange of prisoners of war, which cartel, in so far as it provides for an exchange of prisoners hereafter captured, would never have been signed or agreed to by this Government, if the intention to change the war into a system of indiscriminate murder and robbery had been made known to it. And whereas a just regard to humanity forbids that the repression of crime, which this Government is thus compelled to enforce, should be unnecessarily extended to retaliation on the enlisted men of the army of the United States who may be unwilling instruments of the savage cruelty of their commanders, so long as there is hope that the excesses of the enemy may be checked or prevented by retribution on the commissioned officers, who have the power to avoid guilty action by refusing service under a Government which seeks their aid in the perpetration of such infamous barbarities.

*Seventh.* Therefore it is ordered that Major-General Pope, Brigadier-General Steinwehr, and all commissioned officers serving under their respective commands, be and they are hereby expressly and especially declared to be not entitled to be considered as soldiers, and therefore not entitled to the benefit of the cartel for the parole of future prisoners of war.

*Ordered, further,* That in the event of the capture of Major-General Pope or Brigadier-General Steinwehr, or of any commissioned officers serving under them, the captive so taken shall be held in close confinement, so long as the orders herein expressed shall continue in force, and until repealed by the competent military authorities of the United States, and that in the event of the murder of any unarmed citizen or inhabitant of this Confederacy, by virtue or under the pretext of any of the orders hereinbefore recited, whether with or without trial, whether under the pretence of such citizen being a spy or hostage, or any other pretence, it shall be the duty of the commanding General of the forces of this Confederacy to cause immediately to be hung, out of the commissioned officers prisoners as aforesaid, a number equal to the number of our own citizens thus murdered by the enemy.

By order.

B. COOPER,

Adjutant and Inspector-General.

On the same day, August 2, Gen. Lee addressed the following communication on a different subject, but one involving similar principles, to Gen. Halleck:

HEADQUARTERS OF THE CONFEDERATE STATES, NEAR }  
RICHMOND, VA., Aug. 2, 1862. }

To the General Commanding Army of the United States, Washington:

GENERAL: On the 29th of June last I was instructed by the Secretary of War to inquire of Maj.-Gen. McClellan as to the truth of alleged murders committed on our citizens by officers of the United States army.

The case of Wm. B. Mumford, reported to have been murdered at New Orleans by order of Maj.-Gen. B. F. Butler, and of Col. John Owens, reported to have been murdered in Missouri by order of Maj.-Gen. Pope, were those referred to. I had the honor to be informed by Maj.-Gen. McClellan that he had referred these inquiries to his Government for a reply. No answer has as yet been received.

The President of the Confederate States has since been credibly informed that numerous other officers of the army of the United States within the Confederacy have been guilty of felonies and capital offences which are punishable by all laws, human and divine. I am

directed by him to bring to your notice a few of those best authenticated.

Newspapers received from the United States announce as a fact that Maj.-Gen. Hunter has armed slaves for the murder of their masters, and has thus done all in his power to inaugurate a servile war, which is worse than that of the savage, inasmuch as it superadds other horrors to the indiscriminate slaughter of all ages, sexes, and conditions.

Brig.-Gen. Phelps is reported to have initiated at New Orleans the example set by Maj.-Gen. Hunter on the coast of South Carolina.

Brig.-Gen. G. N. Fitch is stated in the same journals to have murdered in cold blood two peaceful citizens, because one of his men, while invading our country, was killed by some unknown person while defending his home.

I am instructed by the President of the Confederate States to repeat the inquiry relative to the cases of Mumford and Owens, and to ask whether the statements in relation to the action of Gens. Hunter, Phelps, and Fitch are admitted to be true, and whether the conduct of these generals is sanctioned by their Government.

I am further directed by his Excellency the President to give notice that, in the event of not receiving a reply to these inquiries within fifteen days from the delivery of this letter, it will be assumed that the alleged facts are true, and are sanctioned by the Government of the United States. In such an event, on that Government will rest the responsibility of the retribution or retaliatory measures which shall be adopted to put an end to the merciless atrocities which now characterize the war against the Confederate States.

I am, most respectfully, your obedient servant,  
R. E. LEE, General Commanding.

To both communications but one answer was returned, and that was given in the following brief note, with which, for the time, all correspondence on the subject between the parties ended:

HEADQUARTERS OF THE ARMY, WASHINGTON, }  
Aug. 9, 1862. }

Gen. R. E. Lee, Commanding, &c. :

GENERAL: Your two communications of the 2d instant, with enclosure, are received. As these papers are couched in language insulting to the Government of the United States, I most respectfully decline to receive them. They are returned herewith.

Very respectfully, your obedient servant,  
H. W. HALLECK,  
General-in-Chief U. S. Army.

The Confederates, however, not receiving what they considered a satisfactory answer to the allegations contained in the last quoted letter of Gen. Lee, of August 2, proceeded to issue two vindictive orders in the nature of retaliatory measures against officers of the United States army. The first, dated August 20, threatened retaliation for the lives of peaceable citizens said to have been taken by Gen. (Colonel) Fitch in Arkansas, and the second, dated on the succeeding day, and known as General Order No. 60, was to the following effect:

Whereas Maj.-Gen. Hunter, recently in command of the enemy's forces on the coast of South Carolina, and Brig.-Gen. Phelps, a military commander of the enemy in the State of Louisiana, have organized and armed negro slaves for military service against their masters, citizens of this Confederacy:

And whereas the Government of the United States has refused to answer an inquiry whether said conduct of its officers meets its sanction, and has thus left to this Government no other means of repressing said

crimes and outrages than by the adoption of such measures of retaliation as shall serve to prevent their repetition:

Ordered that Maj.-Gen. Hunter and Brig.-Gen. Phelps be no longer held and treated as public enemies of the Confederate States, but as outlaws; and that in the event of the capture of either of them, or that of any other commissioned officer employed in drilling, organizing or instructing slaves, with a view to their armed service in this war, he shall not be regarded as a prisoner of war, but held in close confinement for execution as a felon, at such time and place as the President may order.

The retaliatory orders against Gen. Pope's command were for several weeks enforced with a considerable degree of strictness; but when he retired from command, they were rescinded.

An event occurring in Missouri in October gave occasion for further retaliatory action on the part of the Confederate authorities. Andrew Allsman, a loyal citizen of Palmyra, in the northeastern part of the State, and a non-combatant, having been forcibly abducted by a band of guerillas under the command of one Porter, the latter was notified by Gen. McNeil, commanding a portion of the Missouri State militia, that unless Allsman was returned unharmed to his family by the 18th of October, ten of the captured guerillas would be summarily shot. Allsman not appearing on the day specified, the death penalty was inflicted on ten men selected from Porter's band, in the presence of a large concourse of citizens. Intelligence of this event reached the Confederate capital in due season, and produced the following order from President Davis:

EXECUTIVE OFFICE, RICHMOND, Nov. 17, 1862.

Lieut.-Gen. T. J. Holmes, Commanding, Trans-Mississippi Department:

GENERAL: Enclosed you will find a slip from the Memphis "Daily Appeal" of the 8d instant, containing an account, purporting to be derived from the Palmyra (Missouri) "Courier," a federal journal, of the murder of ten Confederate citizens of Missouri by order of Gen. McNeil of the United States army.

You will communicate by flag of truce with the Federal officer commanding that department, and ascertain if the facts are as stated. If they be so, you will demand the immediate surrender of Gen. McNeil to the Confederate authorities, and, if this demand is not complied with, you will inform said commanding officer that you are ordered to execute the first ten United States officers who may be captured and fall into your hands. Very respectfully, yours,

JEFFERSON DAVIS.

Whether from inability, on the part of Gen. Holmes, to capture the requisite number of United States officers, or in consequence of subsequent instructions received by him, he seems never to have fulfilled the requirements of the order.

The retaliatory order of President Davis, of Dec. 23, elicited by the execution of Mumford in New Orleans, and by various administrative acts of Gen. Butler, and directed against that general, and the officers and negro slaves under his command, will be found among the Public Documents published in this volume.

PROTESTANT EPISCOPAL CHURCH.  
This church is one of the few religious denominations of the United States which maintained

a national organization embracing all the States of the Union until the outbreak of the civil war. After the organization of a government for the seceded States, and the interruption of all communications between the seceded and the Federal States, the Bishops of the former thought it necessary to provide for an independent church organization. A preliminary meeting of the Bishops determined to unite the dioceses of the seceded States into "the Protestant Episcopal Church of the Confederate States." The first "General Council" of the church (this name was adopted for the general assemblies of the church instead of General Synods) met at Augusta, Georgia, on November 12, 1862. A pastoral letter was issued by the House of Bishops. No complaint was raised against the church of the United States, but the abolition movement in the northern States was styled "that hateful and infidel pestilence." Although the bishops accept the doctrine of the perpetuation of slavery, and announce that the "national life of the Confederate States is to be planted upon it," they acknowledge that hitherto the slavery system, in the southern States, has had some "unchristian features," and they, therefore, urge upon the masters of the country "their obligations as Christian men, so to arrange this institution as not to necessitate the violation of those sacred relations which God has created, and which man cannot, consistently with Christian duty, annul," and, in particular, to prevent all necessity for the separation of parents and children, of husbands and wives. The bishops claim to know "that the public sentiment is rapidly becoming sound upon this subject, and that the Legislatures of several of the Confederate States have already taken steps toward this consummation."

The triennial general convention of the Protestant Episcopal Church of the United States met in the city of New York, on Oct. 1, 1862. It was not attended by any bishops or delegates from the seceded dioceses. At the opening of the convention, it was thought that a majority of the House of Delegates would be opposed to any resolutions on the state of the country; but a series was brought in by a special committee of nine, to which all the proposed resolutions of this class had been referred, declaring that the church is teaching the duty of loyalty to the civil authority, regularly and legitimately constituted; that in a spirit of forbearance, the convention refrains from employing any terms of condemnation or reproach toward the ministers or laymen who have arrayed themselves in open and armed resistance to the regularly constituted government of the church; that as individuals and as citizens the members of the convention acknowledge their duty in sustaining and defending the country in the great struggle in which it is engaged, but that as an ecclesiastical body, the convention can pledge to the National Government only earnest and devout prayers for a speedy and complete success. After a long

and animated discussion the resolutions were adopted by a large majority. The convention was closed by a pastoral address, which referred to secession in much stronger terms than the resolutions passed by the lower house, calling secession a sin and a crime against the laws of God and man. Through a debate concerning the authorship of the pastoral address in the denominational organs it was ascertained that the draft of the pastoral letter had been originally prepared by Bishop Hopkins, of Vermont. Bishop McIlvaine of Ohio, not considering the draft sufficiently explicit on the great question involved in the war, proposed a counter-draft. In the committee charged with submitting a draft to the House of Bishops, two bishops (those of Wisconsin and Michigan) voted for the draft of Bishop Hopkins; two (the Bishop of Kentucky and Bishop McIlvaine) for the counter-draft of Bishop McIlvaine. Bishop Hopkins refrained from voting. Thus both drafts came before the House of Bishops, which, on motion of the Bishop of Maryland, gave the preference to the address prepared by Bishop McIlvaine.

The general convention also inaugurated a movement that may become of great importance for the future of the Anglican Church, by appointing a committee to consider the question of "establishing intercommunion with the Russo-Greek Church." The English convocation of Canterbury which met on February 10, 1863, had also a discussion on the same subject and unanimously declared in favor of it. A particular interest in the promotion of the scheme is taken by Rev. George Williams, of King's College, Cambridge, England, who is in correspondence with prominent members of the Russian Church, who have assured him that the prospects for a realization of the plan are good. In former years, the Protestant Episcopal Church had already expressed its desire to establish an official intercourse with the Church of Sweden, which, although Lutheran, is yet strictly Episcopal in its form of government. The Bishop of Illinois, in 1862, received into his diocese an ordained minister of the Church of Sweden upon his letters of orders and other papers. This is believed to be the second case when the Protestant Episcopal Church has expressly acknowledged the validity of the Swedish orders.

The Church has a bishop in each of the United States. The State of New York is divided into 2 dioceses, New York and Western New York; and there is besides a missionary bishop of the Northwest, residing in Nebraska City. The *Church Calendar*, for 1863, gives the following statistics of the church (including the seceded States): clergy, 2,270; parishes, 2,327; communicants, 160,612.

In the British provinces of North America there are sees at Montreal (Metropolitan), Quebec, Toronto, Nova Scotia, Newfoundland, Fredericton, Huron, Rupert's Land, Columbia, and Ontario; in the West Indies, at Barbadoes,

Antigua, Guiana, Jamaica, Kingston, Nassau. The Episcopalian population, according to the official census taken in 1861, was 68,822 in Lower Canada, 811,565 in Upper Canada, 47,744 in Nova Scotia, 44,285 in Newfoundland, 6,787 in Prince Edward's Island.

The most important subject discussed by the provincial synod of the Episcopal Church in Canada was the mode of electing a metropolitan of the Canadian dioceses. Both houses expressed themselves in favor of permanently connecting the dignity of metropolitan with the Episcopal See of Montreal. A committee was appointed to examine how justice could be done to the claims of the Diocese of Montreal as well as to those of the other dioceses of the province, and to make a report to the next provincial synod.

Identical with the Protestant Episcopal Church of this country, is the established Church of England and Ireland, and the Episcopal Church of Scotland, and it is, therefore, common to comprise them together under the name of Anglican Church. The Church of England and Ireland has, in England 2 archbishops and 26 bishops, in Ireland 2 archbishops and 10 bishops. The Episcopal Church of Scotland is a comparatively small body, which has 7 bishops, but not more than about 157 churches and 166 clergy. The Church of England is governed by the two convocations of Canterbury and York, which are regularly convened with Parliament. From the time of George the First until the reign of Victoria the powers of the convocations have been suspended by the Crown and Parliament, but they are now gradually returning, and the proceedings of both become from year to year more interesting and important. The bishops of Ireland will also take steps for having their convocation revived.

One of the most important questions which the convocations of England were called to act upon, during the year 1862, was the doctrinal controversy which had been kindled by that famous volume of theological writing, called, "The Essays and Reviews." In the course of the year, two of the authors, Dr. Williams and Rev. H. B. Wilson, had a suit brought against them, and on June 25th, the Court of Arches gave judgment in their cases, some of the charges against them were rejected, others were ordered to be modified. In accordance with the order of the judge, the charges were altered, and the cause came up again on Dec. 15th. Both the essayists were declared to have taught doctrines contravening some of the articles of the Church of England, and were therefore sentenced to one year's suspension from their livings and the offices and benefits belonging thereto. In both instances, notice of appeal to the privy council was given. The great excitement which the *Essays and Reviews* had produced in the entire theological world, received new fuel by the publication of a work of one of the colonial

bishops—Bishop Colenso of Natal,—who deviated even more than any of the essayists from the old doctrine of the church on inspiration. The organs of the church generally demanded his resignation, but in his case a new difficulty arose. The Bishop appeared to be unwilling to resign, and there seemed to be no law to compel him. Toward the close of the year, notice was given by Archdeacon Denison, that he would move at the first meeting of the convocation of Canterbury, in 1863, an inquiry into the Bishop's case.

As no official census is taken of the membership of the religious denominations in England and Scotland, it is not known how large a portion of the population belongs to the Anglican Church. From a careful comparison of the marriage, educational, and other statistics, it is, however, probable, that in England proper from 65 to 70 per cent. of the population (which, in 1861, amounted to 20,061,725) are connected with the Established Church. In Ireland, the number of the Episcopalian population, according to the official census of 1861, was 687,661, out of a total population of 5,764,548.

Outside of Great Britain the Anglican Church has only one Episcopal See in Europe, at Gibraltar, the bishop of which place has jurisdiction over the churches in Malta, Constantino-ple, and the Mediterranean.

In Asia, there are bishops in connection with the Church of England at Calcutta, Madras, and Bombay in India, at Colombo in Ceylon, at Labuan in Borneo, at Victoria in Hongkong, at Jerusalem; and one bishop in connection with the Protestant Episcopal Church of America, at Amoy, China.

In the British possessions in Africa, there are bishops at Capetown, Grahamstown, Sierra Leone, Natal, St. Helena and Mauritius. For countries outside of the British possessions, missionary bishops have been appointed for Zambezi (1862) and the Orange Territory (1863). The Protestant Episcopal Church of America has sent a missionary bishop to Liberia.

A considerable number of Episcopal Sees have been established in Oceanica; in Australia, there are bishops at Sydney (the bishop of which is the metropolitan of the Australian dioceses), Tasmania, New Castle, Adelaide, Melbourne, Perth, Christ Church, Brisbane and Goulburn (established in 1863). New Zealand has a metropolitan called the Bishop of New Zealand, and the bishops of Christ Church, Nelson, Waiakua, Wellington. A missionary bishop, who has the title of Bishop of Melanesia, was appointed in 1861, for the islands of Polynesia, most of which are not under British rule.

In 1861, at the request of the king of the Sandwich Islands, the diocese of Honolulu was erected, and in 1862, the king, the queen, and the ministers received the rite of confirmation, and the Anglican Church now bears the character of the state church.

**PUBLIC DOCUMENTS.—***Message of President LINCOLN on the Emancipation of Slaves and Compensation to their owners.*

WASHINGTON, March 6, 1862.

*Fellow Citizens of the Senate and House of Representatives :*

I recommend the adoption of a joint resolution by your honorable body which shall be, substantially, as follows :

*Resolved,* That the United States, in order to cooperate with any State which may adopt gradual abolition of slavery, give to such State pecuniary aid, to be used by such State, in its discretion, to compensate it for the inconvenience, public and private, produced by such change of system.

If the proposition contained in the resolution does not meet the approval of Congress and the country, there is an end of it. But if it does command such approval I deem it of importance that the States and people immediately interested should be at once distinctly notified of the fact, so that they may begin to consider whether to accept or reject it.

The Federal Government would find its highest interest in such a measure as one of the most important means of self-preservation. The leaders of the existing rebellion entertain the hope that this Government will ultimately be forced to acknowledge the independence of some part of the disaffected region, and that all the Slave States north of such part will then say, "The Union for which we have struggled being already gone, we now choose to go with the Southern section." To deprive them of this hope substantially ends the rebellion; and the initiation of emancipation deprives them of it, and of all the States initiating it.

The point is not that all the States tolerating slavery would very soon, if at all, initiate emancipation, but while the offer is equally made to all, the more Northern shall, by such initiation, make it certain to the more Southern that in no event will the former ever join the latter in their proposed Confederacy. I say initiation, because, in my judgment, gradual and not sudden emancipation is better for all.

In the mere financial or pecuniary view, any member of Congress, with the census or an abstract of the Treasury report before him, can readily see for himself how very soon the current expenditures of this war would purchase, at a fair valuation, all the slaves in any named State.

Such a proposition on the part of the General Government sets up no claim of a right by the Federal authority to interfere with slavery within State limits—referring as it does the absolute control of the subject, in each case, to the State and the people immediately interested. It is proposed as a matter of perfectly free choice to them.

In the annual Message, last December, I thought fit to say "the Union must be preserved, and hence all indispensable means must be employed." I said this not hastily, but deliberately. War has been made, and continues to be an indispensable means to this end. A practical reacknowledgment of the national authority would render the war unnecessary, and it would at once cease. But resistance continues, and the war must also continue; and it is impossible to foresee all the incidents which may attend, and all the ruin which may follow it. Such as may seem indispensable, or may obviously promise great efficiency toward ending the struggle, must and will come.

The proposition now made (though an offer only), I hope it may be esteemed no offence to ask whether the pecuniary consideration tendered would not be of more value to the States and private persons concerned than would the institution and property in it, in the present aspect of affairs. While it is true that the adoption of the proposed resolution would be merely initiatory, and not within itself a practical measure, it is recommended in the hope that it would lead to important practical results.

In full view of my great responsibility to my God and my country, I earnestly beg the attention of Congress and the people to the subject.

ABRAHAM LINCOLN.

*Proclamation of President LINCOLN countermanding the Emancipation order of General David Hunter, in the Department of the South :*

*Whereas,* There appears in the public prints what purports to be a proclamation of Maj. Gen. Hunter, in the words and figures following :

HEADQUARTERS DEPARTMENT OF THE SOUTH,  
Hilton Head, S. C., May 9, 1862.

General Order No. 11.

The three States of Georgia, Florida, and South Carolina, comprising the Military Department of the South, having deliberately declared themselves no longer under the United States of America, and having taken up arms against the United States, it becomes a military necessity to declare them under martial law.

This was accordingly done on the 25th day of April, 1862. Slavery and martial law in a free country are altogether incompatible. The persons in these States—Georgia, Florida, and South Carolina—heretofore held as slaves, are therefore declared forever free.

[OFFICIAL.] Signed, DAVID HUNTER,  
Major-General Commanding.  
Ed. W. SMITH, Acting Assistant Adj't-Gen.

*And, whereas,* the same is producing some excitement and misunderstanding, therefore I, Abraham Lincoln, President of the United States, proclaim and declare that the Government of the United States had no knowledge or belief of an intention on the part of General Hunter to issue such proclamation, nor has it yet any authentic information that the document is genuine; and, further, that neither General Hunter nor any other commander or person has been authorized by the Government of the United States to make proclamation declaring the slaves of any State free, and that the supposed proclamation now in question, whether genuine or false, is altogether void so far as respects such declaration. I further make known that, whether it be competent for me, as Commander-in-Chief of the Army and Navy, to declare the slaves of any State or States, free; and whether at any time, or in any case, it shall have become a necessity indispensable to the maintenance of the Government to examine such supposed power, are questions which, under my responsibility, I reserve to myself, and which I cannot feel justified in leaving to the decision of commanders in the field.

These are totally different questions from those of police regulations in armies in camps.

On the 6th day of March last, by a special Message, I recommended to Congress the adoption of a joint resolution, to be substantially as follows :

*Resolved,* That the United States ought to cooperate with any State which may adopt a gradual abolishment of slavery, giving to such State earnest expression to compensate for its inconveniences, public and private, produced by such change of system.

The resolution in the language above quoted was adopted by large majorities in both branches of Congress, and now stands an authentic, definite, and solemn proposal of the Nation to the States and people most interested in the subject matter. To the people of these States now, I mostly appeal. I do not argue—I beseech you to make the arguments for yourselves. You cannot, if you would, be blind to the signs of the times.

I beg of you a calm and enlarged consideration of them, ranging, if it may be, far above partisan and personal politics.

This proposal makes common cause for a common object, casting no reproaches upon any. It acts not the Pharisee. The change it contemplates would come gently as the dews of Heaven, not rending or wrecking anything. Will you not embrace it? So much good has not been done by one effort in all past time, as in the Providence of God, it is now your high privilege to do. May the vast future not have to lament that you have neglected it.

In witness whereof I have hereunto set my hand and caused the seal of the United States to be hereunto affixed.

Done at the City of Washington this 19th day of May, in the year of our Lord one thousand eight hundred and sixty-two, and of the independence of the United States the eighty-sixth.

(Signed) ABRAHAM LINCOLN.

By the President:

W. H. SEWARD, Secretary of State.

*Appeal of President LINCOLN to the Border States on Emancipation.*

The Representatives and Senators of the Border Slaveholding States having, by special invitation of the President, been convened at the Executive Mansion on Saturday morning, July 12, President LINCOLN addressed them as follows from a written paper held in his hands:

GENTLEMEN: After the adjournment of Congress, now near, I shall have no opportunity of seeing you for several months. Believing that you of the Border States hold more power for good than any other equal number of members, I feel it a duty which I cannot justifiably waive to make this appeal to you.

I intend no reproach or complaint when I assure you that, in my opinion, if you all had voted for the resolution in the gradual emancipation Message of last March the war would now be substantially ended. And the plan therein proposed is yet one of the most potent and swift means of ending it. Let the States which are in rebellion see definitely and certainly that in no event will the States you represent ever join their proposed Confederacy, and they cannot much longer maintain the contest. But you cannot divest them of their hope to ultimately have you with them so long as you show a determination to perpetuate the institution within your own States. Beat them at elections, as you have overwhelmingly done, and, nothing daunted, they still claim you as their own. You and I know what the lever of their power is. Break that lever before their faces, and they can shake you no more forever.

Most of you have treated me with kindness and consideration, and I trust you will not now think I improperly touch what is exclusively your own, when, for the sake of the whole country, I ask, Can you, for your States, do better than to take the course I urge? Discarding *punctilio* and maxims adapted to more manageable times, and looking only to the unprecedentedly stern facts of our case, can you do better in any possible event? You prefer that the constitutional relation of the States to the nation shall be practically restored without disturbance of the institution: and if this were done, my whole duty, in this respect, under the Constitution and my oath of office, would be performed. But it is not done, and we are trying to accomplish it by war. The incidents of the war cannot be avoided. If the war continues long, as it must if the object be not sooner attained, the institution in your States will be extinguished by mere friction and abrasion—by the mere incidents of the war. It will be gone, and you will have nothing valuable in lieu of it. Much of its value is gone already. How much better for you and for your people to take the step which at once shortens the war, and secures substantial compensation for that which is sure to be wholly lost in any other event! How much better to thus save the money which else we sink forever in the war! How much better to do it while we can, lest the war ere long render us pecuniarily unable to do it! How much better for you, as seller, and the nation, as buyer, to sell out and buy out that without which the war could never have been, than to sink both the thing to be sold and the price of it in cutting one another's throats!

I do not speak of emancipation at once, but of a decision at once to emancipate gradually. Room in South America for colonization can be obtained cheaply, and in abundance, and when numbers shall be

large enough to be company and encouragement for one another, the freed people will not be so reluctant to go.

I am pressed with a difficulty not yet mentioned—one which threatens division among those who, united, are none too strong. An instance of it is known to you. Gen. Hunter is an honest man. He was, and I hope still is, my friend. I valued him none the less for his agreeing with me in the general wish that all men everywhere could be free. He proclaimed all men free within certain States, and I repudiated the proclamation. He expected more good and less harm from the measure than I could believe would follow. Yet, in repudiating it, I gave dissatisfaction, if not offence, to many whose support the country cannot afford to lose. And this is not the end of it. The pressure in this direction is still upon me and is increasing. By conceding what I now ask you can relieve me, and, much more, can relieve the country in this important point.

Upon these considerations I have again begged your attention to the Message of March last. Before leaving the Capitol, consider and discuss it among yourselves. You are patriots and statesmen, and as such I pray you consider this proposition; and at the least commend it to the consideration of your States and people. As you would perpetuate popular government for the best people in the world, I beseech you that you do in no wise omit this. Our common country is in great peril, demanding the loftiest views and boldest action to bring a speedy relief. Once relieved, its form of government is saved to the world; its beloved history and cherished memories are vindicated, and its happy future fully assured and rendered inconceivably grand. To you, more than to any others, the privilege is given to assure that happiness and swell that grandeur, and to link your own names therewith forever.

At the conclusion of these remarks some conversation was had between the President and several members of the delegations from the Border States, in which it was represented that these States could not be expected to move in so great a matter as that brought to their notice in the foregoing address while as yet the Congress had taken no step beyond the passage of a resolution, expressive rather of a sentiment than presenting a substantial and reliable basis of action.

The President acknowledged the force of this view, and admitted that the Border States were entitled to expect a substantial pledge of pecuniary aid as the condition of taking into consideration a proposition so important in its relations to their social system.

It was further represented, in the conference, that the people of the Border States were interested in knowing the great importance which the President attached to the policy in question, while it was equally due to the country, to the President, and to themselves that the representatives of the Border Slaveholding States should publicly announce the motives under which they were called to act and the considerations of public policy urged upon them and their constituents by the President.

With a view to such a statement of their position, the members thus addressed, met in council to deliberate on the reply they should make to the President, and, as the result of a comparison of opinions among themselves, they determined upon the adoption of a majority and a minority answer.

## REPLY OF THE MAJORITY.

The following paper was sent to the President, signed by the majority of the representatives from the Border Slaveholding States. It was prepared by J. W. Crisfield, of Maryland:

WASHINGTON, July 14, 1862.

To the President:

The undersigned, Representatives of Kentucky, Virginia, Missouri, and Maryland, in the two Houses of Congress, have listened to your address with the profound sensibility naturally inspired by the high source from which it emanates, the earnestness which marked its delivery, and the overwhelming importance of the subject of which it treats. We have given it a most respectful consideration, and now lay before you our response. We regret that want of time has not permitted us to make it more perfect.

We have not been wanting, Mr. President, in respect to you, and in devotion to the Constitution and the Union. We have not been indifferent to the great difficulties surrounding you, compared with which all former national troubles have been but as the summer cloud; and we have freely given you our sympathy and support. Repudiating the dangerous heresies of the secessionists, and believing, with you, that the war on their part is aggressive and wicked, and the objects for which it was to be prosecuted on ours, as defined by your Message at the opening of the present Congress, to be such as all good men should approve, we have not hesitated to vote all supplies necessary to carry it on vigorously. We have voted all the men and money you have asked for, and even more; we have imposed onerous taxes on our people, and they are paying them with cheerfulness and alacrity; we have encouraged enlistments and sent to the field many of our best men; and some of our number have offered their persons to the enemy as pledges of their sincerity and devotion to the country. We have done all this under the most discouraging circumstances and in the face of measures most distasteful to us and injurious to the interests we represent, and in the hearing of doctrines avowed by those who claim to be your friends most abhorrent to us and our constituents. But, for all this, we have never faltered, nor shall we as long as we have a Constitution to defend and a Government which protects us. And we are ready for renewed efforts, and even greater sacrifices, yes, any sacrifice, when we are satisfied it is required to preserve our admirable form of government and the priceless blessings of constitutional liberty.

A few of our number voted for the resolution recommended by your Message of the 6th of March last; the greater portion of us did not, and we will briefly state the prominent reasons which influenced our action.

In the first place, it proposed a radical change of our social system, and was hurried through both Houses with undue haste, without reasonable time for consideration and debate, and with no time at all for consultation with our constituents, whose interests it deeply involved. It seemed like an interference by this Government with a question which peculiarly and exclusively belonged to our respective States, on which they had not sought advice or solicited aid. Many of us doubted the constitutional power of this Government to make appropriations of money for the object designated, and all of us thought our finances were in no condition to bear the immense outlay which its adoption and faithful execution would impose upon the National Treasury. If we pause but a moment to think of the debt its acceptance would have entailed, we are appalled by its magnitude. The proposition was addressed to all the States, and embraced the whole number of slaves. According to the census of 1860, there were then very nearly four million slaves in the country; from natural increase they exceed that number now. At even the low average of three hundred dollars, the price fixed by the emancipation act for the slaves of this District, and greatly below their real worth,

their value runs up to the enormous sum of twelve hundred millions of dollars; and if to that we add the cost of deportation and colonization, at one hundred dollars each, which is but a fraction more than is actually paid by the Maryland Colonization Society, we have four hundred millions more! We were not willing to impose a tax on our people sufficient to pay the interest on that sum, in addition to the vast and daily increasing debt already fixed upon them by the exigencies of the war; and, if we had been willing, the country could not bear it. Stated in this form the proposition is nothing less than the deportation from the country of sixteen hundred million dollars' worth of producing labor, and the substitution in its place of an interest-bearing debt of the same amount!

But, if we are told that it was expected that only the States we represent would accept the proposition, we respectfully submit that even then it involves a sum too great for the financial ability of this Government at this time. According to the census of 1860—

Kentucky had.....	325,490 slaves.
Maryland.....	67,188 "
Virginia.....	490,887 "
Delaware.....	1,798 "
Missouri.....	114,965 "
Tennessee.....	275,784 "

Making in the whole.....1,196,119 "

At the same rate of valuation these would amount to.....\$358,833,600  
Add for deportation and colonization \$100 each..... 119,244,568

And we have the enormous sum of..... \$478,078,168

We did not feel that we should be justified in voting for a measure which, if carried out, would add this vast amount to our public debt at a moment when the Treasury was reeling under the enormous expenditures of the war.

Again, it seemed to us that this resolution was but the annunciation of a sentiment which could not, or was not likely to be, reduced to an actual, tangible proposition. No movement was then made to provide and appropriate the funds required to carry it into effect; and we were not encouraged to believe that funds would be provided. And our belief has been fully justified by subsequent events. Not to mention other circumstances, it is quite sufficient for our purpose to bring to your notice the fact, that, while this resolution was under consideration in the Senate, our colleague, the Senator from Kentucky, moved an amendment appropriating \$500,000 to the object therein designated, and it was voted down with great unanimity. What confidence, then, could we reasonably feel that if we committed ourselves to the policy it proposed, our constituents would reap the fruits of the promise held out; and on what ground could we, as fair men, approach them and challenge their support?

The right to hold slaves is a right appertaining to all the States of this Union. They have the right to cherish or abolish the institution, as their tastes or their interests may prompt, and no one is authorized to question the right, or limit its enjoyment. And no one has more clearly affirmed that right than you have. Your inaugural address does you great honor in this respect, and inspired the country with confidence in your fairness and respect for the law. Our States are in the enjoyment of that right. We do not feel called on to defend the institution, or to affirm it is one which ought to be cherished; perhaps, if we were to make the attempt, we might find that we differ even among ourselves. It is enough for our purpose to know that it is a right; and, so knowing, we did not see why we should now be expected to yield it. We had contributed our full share to relieve the country at this terrible crisis; we had done as much as had been required of others, in like circumstances; and we did not see why sacrifices should be expected of us from which others, not more loyal, were exempt. Nor could we see what good the nation would derive from it. Such a sacrifice submitted to by us would not have strengthened the arm of this Government or weakened that of

the enemy. It was not necessary as a pledge of our loyalty, for that had been manifested beyond a reasonable doubt, in every form, and at every place possible. There was not the remotest probability that the States we represent would join in the rebellion, nor is there now; or of their electing to go with the Southern section in the event of a recognition of the independence of any part of the disaffected region. Our States are fixed unalterably in their resolution to adhere to and support the Union; they see no safety for themselves and no hope for constitutional liberty but by its preservation. They will under no circumstances consent to its dissolution, and we do them no more than justice when we assure you that while the war is conducted to prevent that deplorable catastrophe, they will sustain it as long as they can muster a man or command a dollar. Nor will they ever consent, in any event, to unite with the Southern Confederacy. The bitter fruits of the peculiar doctrines of that region will forever prevent them from placing their security and happiness in the custody of an association which has incorporated in its organic law the seeds of its own destruction.

We cannot admit, Mr. President, that if we had voted for the resolution in the emancipation Message of March last the war would now be substantially ended. We are unable to see how our action in this particular has given, or could give, encouragement to the rebellion. The resolution has passed; and if there be virtue in it, it will be quite as efficacious as if we had voted for it. We have no power to bind our States in this respect by our votes here; and whether we had voted the one way or the other, they are in the same condition of freedom to accept or reject its provisions. No, sir; the war has not been prolonged or hindered by our action on this or any other measure. We must look for other causes for that lamented fact. We think there is not much difficulty, not much uncertainty, in pointing out others far more probable and potent in their agencies to that end.

The rebellion derives its strength from the union of all classes in the insurgent States; and while that union lasts the war will never end until they are utterly exhausted. We know that at the inception of these troubles Southern society was divided, and that a large portion, perhaps a majority, were opposed to secession. Now the great mass of Southern people are united. To discover why they are so we must glance at Southern society, and notice the classes into which it has been divided, and which still distinguish it. They are in arms, but not for the same objects; they are moved to a common end, but by different and even inconsistent reasons. The leaders, which word comprehends those who were previously known as the State Rights party, and which party is much the lesser class, seek to break down national independence and set up State domination. With them it is a war against nationality. The other class is fighting, as it supposes, to maintain and preserve its rights of property and domestic safety, which it has been made to believe are assailed by this Government. This latter class are not disunionists *per se*; they are so only because they have been made to believe that this Administration is inimical to their rights, and is making war on their domestic institutions. As long as these two classes act together they will never assent to a peace. The policy, then, to be pursued is obvious. The former class will never be reconciled, but the latter may be. Remove their apprehensions; satisfy them that no harm is intended to them and their institutions; that this Government is not making war on their rights of property, but is simply defending its legitimate authority, and they will gladly return to their allegiance as soon as the pressure of military dominion imposed by the Confederate authority is removed from them.

Twelve months ago both Houses of Congress, adopting the spirit of your Message, then but recently sent in, declared with singular unanimity the objects of the war, and the country instantly bounded to your side to assist you in carrying it on. If the spirit of that resolution had been adhered to, we are confident that we should before now have seen the end of this

deplorable conflict. But what have we seen? In both Houses of Congress we have heard doctrines subversive of the principles of the Constitution, and seen measure after measure founded in substance on those doctrines proposed and carried through, which can have no other effect than to distract and divide loyal men, and exasperate and drive still further from us and their duty the people of the rebellious States. Military officers, following these bad examples, have stepped beyond the just limits of their authority in the same direction, until in several instances you have felt the necessity of interfering to arrest them. And even the passage of the resolution to which you refer has been ostentatiously proclaimed as the triumph of a principle which the people of the Southern States regard as ruinous to them. The effect of these measures was foretold, and may now be seen in the indurated state of Southern feeling.

To these causes, Mr. President, and not to our omission to vote for the resolution recommended by you, we solemnly believe we are to attribute the terrible earnestness of those in arms against the Government, and the continuance of the war. Nor do we (permit us to say, Mr. President, with all respect for you) agree that the institution of slavery is 'the lever of their power,' but we are of the opinion that 'the lever of their power' is the apprehension that the powers of a common Government, created for common and equal protection to the interests of all, will be wielded against the institutions of the Southern States.

There is one other idea in your address we feel called on to notice. After stating the fact of your repudiation of Gen. Hunter's proclamation, you add:

Yet, in repudiating it, I gave dissatisfaction, if not offence, to many whose support the country cannot afford to lose. And this is not the end of it. The pressure in this direction is still upon me and is increasing. By conceding what I now ask, you can relieve me, and, much more, can relieve the country in this important point.

We have anxiously looked into this passage to discover its true import, but we are yet in painful uncertainty. How can we, by conceding what you now ask, relieve you and the country from the increasing pressure to which you refer? We will not allow ourselves to think that the proposition is, that we consent to give up slavery, to the end that the Hunter proclamation may be let loose on the Southern people, for it is too well known that we would not be parties to any such measure, and we have too much respect for you to imagine you would propose it. Can it mean that by sacrificing our interest in slavery we appease the spirit that controls that pressure, cause it to be withdrawn, and rid the country of the pestilent agitation of the slavery question? We are forbidden so to think, for that spirit would not be satisfied with the liberation of seven hundred thousand slaves, and cease its agitation, while three millions remain in bondage. Can it mean that by abandoning slavery in our States, we are removing the pressure from you and the country, by preparing for a separation on the line of the Cotton States? We are forbidden so to think, because it is known that we are, and we believe that you are, unalterably opposed to any division at all. We would prefer to think that you desire this concession as a pledge of our support, and thus enable you to withstand a pressure which weighs heavily on you and the country. Mr. President, no such sacrifice is necessary to secure our support. Confine yourself to your constitutional authority; confine your subordinates within the same limits; conduct this war solely for the purpose of restoring the Constitution to its legitimate authority; concede to each State and its loyal citizens their just rights, and we are wedded to you by indissoluble ties. Do this, Mr. President, and you touch the American heart and invigorate it with new hope. You will, as we solemnly believe, in due time restore peace to your country, lift it from despondency to a future of glory; and preserve to your countrymen, their posterity, and man, the inestimable treasure of constitutional government.

Mr. President, we have stated with frankness and



candor the reasons on which we forbore to vote for the resolution you have mentioned; but you have again presented this proposition, and appealed to us, with an earnestness and eloquence which have not failed to impress us, to "consider it, and at the least to commend it to the consideration of our States and people." Thus appealed to by the Chief Magistrate of our beloved country, in the hour of its greatest peril, we cannot wholly decline. We are willing to trust every question relating to their interest and happiness to the consideration and ultimate judgment of our own people. While differing from you as to the necessity of emancipating the slaves of our States as a means of putting down the rebellion, and while protesting against the propriety of any extra territorial interference to induce the people of our States to adopt any particular line of policy on a subject which peculiarly and exclusively belongs to them, yet when you and our brethren of the loyal States sincerely believe that the retention of slavery by us is an obstacle to peace and national harmony, and are willing to contribute pecuniary aid to compensate our States and people for the inconveniences produced by such a change of system, we are not unwilling that our people shall consider the propriety of putting it aside.

But we have already said that we regarded this resolution as the utterance of a sentiment, and had no confidence that it would assume the shape of a tangible practical proposition, which would yield the fruits of the sacrifice it required. Our people are influenced by the same want of confidence, and will not consider the proposition in its present impalpable form. The interest they are asked to give up is to them of immense importance, and they ought not to be expected even to entertain the proposal until they are assured that when they accept it their just expectations will not be frustrated. We regard your plan as a proposition from the Nation to the States to exercise an admitted constitutional right in a particular manner and yield up a valuable interest. Before they ought to consider the proposition it should be presented in such a tangible, practical, efficient shape as to command their confidence that its fruits are contingent only upon their acceptance. We cannot trust anything to the contingencies of future legislation. If Congress, by proper and necessary legislation, shall provide sufficient funds and place them at your disposal to be applied by you to the payment of any of our States or the citizens thereof who shall adopt the abolishment of slavery, either gradual or immediate, as they may determine, and the expense of deportation and colonization of the liberated slaves, then will our States and people take this proposition into careful consideration, for such decision as in their judgment is demanded by their interests, their honor, and their duty to the whole country. We have the honor to be, with great respect,

C. A. WICKLIFFE, Chairman, of Kentucky.  
 GARRETT DAVIS, of Kentucky.  
 R. WILSON, of Missouri.  
 J. J. CRITTENDEN, of Kentucky.  
 JNO. S. CARLILE, of Western Virginia.  
 J. W. CRISFIELD, of Maryland.  
 J. S. JACKSON, of Kentucky.  
 H. GRIDER, of Kentucky.  
 JOHN S. PHELPS, of Missouri.  
 FRANCIS THOMAS, of Maryland.  
 CHARLES B. CALVERT, of Maryland.  
 C. L. L. LEARY, of Maryland.  
 EDWIN H. WEBSTER, of Maryland.  
 R. MALLORY, of Kentucky.  
 AARON HARDING, of Kentucky.  
 JAMES S. ROLLINS, of Missouri.  
 J. W. MENZIES, of Kentucky.  
 THOS. L. PRICE, of Missouri.  
 G. W. DUNLAP, of Kentucky.  
 WM. A. HALL, of Missouri.

REPLY OF THE MINORITY.

WASHINGTON, July 15, 1862.

MR. PRESIDENT: The undersigned, Members of Congress from the Border States, in response to your ad-

dress of Saturday last, beg leave to say that they attended a meeting on the same day the address was delivered for the purpose of considering the same. The meeting appointed a committee to report a response to your address. That report was made on yesterday, and the action of the majority indicated clearly that the response reported, or one in substance the same, would be adopted and presented to you.

Inasmuch as we cannot, consistently with our own sense of duty to the country, under the existing perils which surround us, concur in that response, we feel it to be due to you and to ourselves to make you a brief and candid answer over our own signatures.

We believe that the whole power of the Government, upheld and sustained by all the influences and means of all loyal men in all sections, and of all parties, is essentially necessary to put down the rebellion and preserve the Union and the Constitution. We understand your appeal to us to have been made for the purpose of securing this result. A very large portion of the people in the Northern States believe that slavery is the "lever power of the rebellion." It matters not whether this opinion is well-founded or not. The belief does exist, and we have to deal with things as they are, and not as we would have them be. In consequence of the existence of this belief, we understand that an immense pressure is brought to bear for the purpose of striking down this institution through the exercise of military authority. The Government cannot maintain this great struggle if the support and influence of the men who entertain these opinions be withdrawn. Neither can the Government hope for early success if the support of that element called "conservative" be withdrawn.

Such being the condition of things, the President appeals to the Border State men to step forward and prove their patriotism by making the first sacrifice. No doubt like appeals have been made to extreme men in the North to meet us half way, in order that the whole moral, political, pecuniary, and physical force of the nation may be firmly and earnestly united in one grand effort to save the Union and the Constitution.

Believing that such were the motives that prompted your address, and such the results to which it looked, we cannot reconcile it to our sense of duty, in this trying hour, to respond in a spirit of fault-finding or querulousness over the things that are past. We are not disposed to seek for the cause of present misfortunes in the errors and wrongs of others who now propose to unite with us in a common purpose. But, on the other hand, we meet your address in the spirit in which it was made, and, as loyal Americans, declare to you and to the world that there is no sacrifice that we are not ready to make to save the Government and institutions of our fathers. That we, few of us though there may be, will permit no men, from the North or from the South, to go farther than we in the accomplishment of the great work before us. That, in order to carry out these views, we will, so far as may be in our power, ask the people of the Border States, calmly, deliberately, and fairly to consider your recommendations. We are the more emboldened to assume this position from the fact, now become history, that the leaders of the Southern rebellion have offered to abolish slavery amongst them as a condition to foreign intervention in favor of their independence as a nation.

If they can give up slavery to destroy the Union, we can surely ask our people to consider the question of emancipation to save the Union.

With great respect, your obedient servants,

JOHN W. NOELL, of Missouri.  
 SAM. S. CASEY, of Kentucky.  
 GEORGE P. FISHER, of Delaware.  
 A. J. CLEMENTS, of Tennessee.  
 WM. G. BROWN, of Western Virginia.  
 JACOB B. BLAIR, of Western Virginia.  
 W. F. WILLEY, of Western Virginia.

REPLY OF MR. MAYNARD, OF TENNESSEE.

HOUSE OF REPRESENTATIVES, July 16, 1862.

SIR: The magnitude and gravity of the proposition submitted by you to Representatives from the Slave States would naturally occasion diversity, if not contrariety of opinion. You will not, therefore, be surprised that I have not been able to concur in view with the majority of them. This is attributable, possibly, to the fact that my State is not a Border State, properly so called, and that my immediate constituents are not yet disenthralled from the hostile arms of the rebellion. This fact is a physical obstacle in the way of my now submitting to their consideration this or any other proposition looking to political action, especially such as, in this case, would require a change in the organic law of the State.

But do not infer that I am insensible to your appeal. I am not. You are surrounded with difficulties far greater than have embarrassed any of your predecessors. You need the support of every American citizen, and you ought to have it, active, zealous, and honest. The union of every Union man to aid you in preserving the Union is the duty of the time. Differences as to policy and methods must be subordinated to the common purpose.

In looking for the causes of this rebellion, it is natural that each section and each party should ascribe as little blame as possible to itself, and as much as possible to its opponent section and party. Possibly you and I might not agree on a comparison of our views. That there should be differences of opinion as to the best mode of conducting our military operations, and the best men to lead our armies, is equally natural. Contests on such questions weaken ourselves and strengthen our enemies. They are unprofitable and possibly unpatriotic. Somebody must yield, or we waste our strength in a contemptible struggle amongst ourselves.

You appeal to the loyal men of the Slave States to sacrifice something of feeling and a great deal of interest. The sacrifices they have already made and the sufferings they have endured give the best assurance that the appeal will not have been made in vain. He who is not ready to yield all his material interests, and to forego his most cherished sentiments and opinions for the preservation of his country, although he may have perilled his life on the battle-field in her defence, is but half a patriot. Among the loyal people that I represent there are no half patriots.

Already the rebellion has cost us much, even to our undoing; we are content, if need be, to give up the rest to suppress it. We have stood by you from the beginning of this struggle, and we mean to stand by you, God willing, till the end of it.

I did not vote for the resolution to which you allude, solely for the reason that at the time I was absent at the capital of my own State. It is right.

Should any of the Slave States think proper to terminate that institution, as several of them, I understand, or at least some of their citizens propose, justice and a generous comity require that the country should interpose to aid it in lessening the burden, public and private, occasioned by so radical a change in its social and industrial relations.

I will not now speculate upon the effect, at home or abroad, of the adoption of your policy, nor inquire what action of the rebel leaders has rendered something of the kind important. Your whole administration gives the highest assurance that you are moved, not so much from a desire to see all men everywhere made free, as from a far higher desire to preserve free institutions for the benefit of men already free; not to make slaves freemen, but to prevent freemen from being made slaves; not to destroy an institution which a portion of us only consider bad, but to save institutions which we all alike consider good. I am satisfied that you would not ask from any of your fellow citizens a sacrifice not, in your judgment, imperatively required by the safety of the country.

This is the spirit of your appeal, and I respond to it in the same spirit.

I am, very respectfully, your obedient servant,  
HORACE MAYNARD.

To the PRESIDENT.

*Proclamation of President LINCOLN on the  
Emancipation of the Slaves.*

I, ABRAHAM LINCOLN, President of the United States of America, and Commander-in-Chief of the army and navy thereof, do hereby proclaim and declare that hereafter, as heretofore, the war will be prosecuted for the object of practically restoring the constitutional relation between the United States and each of the States, and the people thereof, in which States that relation is or may be suspended or disturbed.

That it is my purpose, upon the next meeting of Congress, to again recommend the adoption of a practical measure tendering pecuniary aid to the free acceptance or rejection of all Slave States, so called, the people whereof may not then be in rebellion against the United States, and which States may then have voluntarily adopted, or thereafter may voluntarily adopt, immediate or gradual abolishment of slavery within their respective limits; and that the effort to colonize persons of African descent, with their consent, upon this continent or elsewhere, with the previously obtained consent of the governments existing there, will be continued.

That on the first day of January, in the year of our Lord one thousand eight hundred and sixty-three, all persons held as slaves within any State, or designated part of a State, the people whereof shall then be in rebellion against the United States, shall be then, thenceforward, and forever free; and the Executive Government of the United States, including the military and naval authority thereof, will recognize and maintain the freedom of such persons, and will do no act or acts to repress such persons, or any of them, in any efforts they may make for their actual freedom.

That the Executive will, on the first day of January aforesaid, by proclamation, designate the States and parts of States, if any, in which the people thereof respectively shall then be in rebellion against the United States; and the fact that any State, or the people thereof, shall on that day be in good faith represented in the Congress of the United States, by members chosen thereto at elections wherein a majority of the qualified voters of such State shall have participated, shall, in the absence of strong countervailing testimony, be deemed conclusive evidence that such State, and the people thereof, are not then in rebellion against the United States.

That attention is hereby called to an act of Congress entitled "An Act to make an additional Article of War," approved March 18, 1862, and which act is in the words and figures following:

*As it enacted by the Senate and House of Representatives of the United States of America in Congress assembled.* That hereafter the following shall be promulgated as an additional article of war for the government of the army of the United States, and shall be obeyed and observed as such:

ARTICLE.—All officers or persons in the military or naval service of the United States are prohibited from employing any of the forces under their respective commands for the purpose of returning fugitives from service or labor who may have escaped from any persons to whom such service or labor is claimed to be due; and any officer who shall be found guilty by a court martial of violating this article shall be dismissed from the service.

SEC. 2. *And be it further enacted,* That this act shall take effect from and after its passage.

Also, to the ninth and tenth sections of an act entitled "An Act to Suppress Insurrection, to Punish Treason and Rebellion, to Seize and Confiscate Property of Rebels, and for other Purposes," approved July 17, 1862, and which sections are in the words and figures following:

SEC. 9. *And be it further enacted,* That all slaves of per-

sons who shall hereafter be engaged in rebellion against the Government of the United States, or who shall in any way give aid or comfort thereto, escaping from such persons and taking refuge within the lines of the army; and all slaves captured from such persons, or deserted by them and coming under the control of the Government of the United States; and all slaves of such persons found on [or] being within any place occupied by rebel forces and afterward occupied by the forces of the United States, shall be deemed captives of war, and shall be forever free of their servitude, and not again held as slaves.

Sec. 10. *And be it further enacted*, That no slave escaping into any State, Territory, or the District of Columbia, from any other State, shall be delivered up, or in any way impeded or hindered of his liberty, except for crime, or some offence against the laws, unless the person claiming said fugitive shall first make oath that the person to whom the labor or service of such fugitive is alleged to be due is his lawful owner, and has not borne arms against the United States in the present rebellion, nor in any way given aid and comfort thereto; and no person engaged in the military or naval service of the United States shall, under any pretence whatever, assume to decide on the validity of the claim of any person to the service or labor of any other person, or surrender up any such person to the claimant, on pain of being dismissed from the service.

And I do hereby enjoin upon and order all persons engaged in the military and naval service of the United States to observe, obey, and enforce, within their respective spheres of service, the act and sections above recited.

And the Executive will in due time recommend that all citizens of the United States who shall have remained loyal thereto throughout the rebellion shall (upon the restoration of the constitutional relation between the United States and their respective States and people, if that relation shall have been suspended or disturbed) be compensated for all losses by acts of the United States, including the loss of slaves.

In witness whereof I have hereunto set my hand and caused the seal of the United States to be affixed.

Done at the city of Washington, this twenty-second day of September, in the year of our [SEAL.] Lord one thousand eight hundred and sixty-two, and of the Independence of the United States the eighty-seventh.

ABRAHAM LINCOLN.

By the President:

WILLIAM H. SEWARD, Secretary of State.

*Message of President LINCOLN at the third session of the Thirty-seventh Congress, Dec. 1, 1862.*

*Follow Citizens of the Senate and House of Representatives:*

Since your last annual assembling another year of health and bountiful harvests has passed. And while it has not pleased the Almighty to bless us with a return of peace, we can but press on, guided by the best light he gives us, trusting that, in his own good time and wise way, all will yet be well.

The correspondence touching foreign affairs which has taken place during the last year is herewith submitted, in virtual compliance with a request to that effect made by the House of Representatives near the close of the last session of Congress.

If the condition of our relations with other nations is less gratifying than it has usually been at former periods, it is certainly more satisfactory than a nation so unhappily distracted as we are might reasonably have apprehended. In the month of June last there were some grounds to expect that the maritime Powers which, at the beginning of our domestic difficulties, so unwisely and unnecessarily, as we think, recognized the insurgents as a belligerent, would soon recede from that position, which has proved only less injurious to themselves than to our own country. But the temporary reverses which afterward befell the national arms, and which were exaggerated by our own disloyal citizens abroad, have hitherto delayed that act of simple justice.

The civil war which has so radically changed, for the moment, the occupations and habits of the Ameri-

can people, has necessarily disturbed the social condition, and affected very deeply the prosperity of the nations with which we have carried on a commerce that has been steadily increasing throughout a period of half a century. It has, at the same time, excited political ambitions and apprehensions which have produced a profound agitation throughout the civilized world. In this unusual agitation we have forborne from taking part in any controversy between foreign states, and between parties or factions in such states. We have attempted no propagandism, and acknowledged no revolution. But we have left to every nation the exclusive conduct and management of its own affairs. Our struggle has been, of course, contemplated by foreign nations with reference less to its own merits, than to its supposed and often exaggerated effects and consequences resulting to those nations themselves. Nevertheless, complaint on the part of this Government, even if it were just, would certainly be unwise.

The treaty with Great Britain for the suppression of the slave trade has been put into operation with a good prospect of complete success. It is an occasion of special pleasure to acknowledge that the execution of it, on the part of her Majesty's Government, has been marked with a jealous respect for the authority of the United States and the rights of their moral and loyal citizens.

The convention with Hanover for the abolition of the slave dues has been carried into full effect, under the act of Congress for that purpose.

A blockade of three thousand miles of seacoast could not be established and vigorously enforced, in a season of great commercial activity like the present, without committing occasional mistakes, and inflicting unintentional injuries upon foreign nations and their subjects.

A civil war occurring in a country where foreigners reside and carry on trade under treaty stipulations is necessarily fruitful of complaints of the violation of neutral rights. All such collisions tend to excite misapprehensions, and possibly to produce mutual reclamations between nations which have a common interest in preserving peace and friendship. In clear cases of these kinds I have, so far as possible, heard and redressed complaints which have been presented by friendly Powers. There is still, however, a large and an augmenting number of doubtful cases upon which the Government is unable to agree with the Governments whose protection is demanded by the claimants. There are, moreover, many cases in which the United States, or their citizens, suffer wrongs from the naval or military authorities of foreign nations, which the Governments of these states are not at once prepared to redress. I have proposed to some of the foreign states thus interested, mutual conventions to examine and adjust such complaints. This proposition has been made especially to Great Britain, to France, to Spain, and to Prussia. In each case it has been kindly received, but has not yet been formally adopted.

I deem it my duty to recommend an appropriation in behalf of the owners of the Norwegian bark Admiral P. Tordenskiold, which vessel was, in May, 1861, prevented by the commander of the blockading force off Charleston from leaving that port with cargo, notwithstanding a similar privilege had, shortly before, been granted to an English vessel. I have directed the Secretary of State to cause the papers in the case to be communicated to the proper committees.

Applications have been made to me by many free Americans of African descent to favor their emigration, with a view to such colonization as was contemplated in recent acts of Congress. Other parties, at home and abroad—some from interested motives, others upon patriotic considerations, and still others influenced by philanthropic sentiments—have suggested similar measures; while, on the other hand, several of the Spanish-American Republics have protested against the sending of such colonies to their respective territories. Under these circumstances I have declined to move any such colony to any state without first obtaining the consent of its Government, with an agreement on its part to receive and protect such emigrants in all the

rights of freemen: and I have, at the same time, offered to the several states situated within the tropics, or having colonies there, to negotiate with them, subject to the advice and consent of the Senate, to favor the voluntary emigration of persons of that class to their respective territories, upon conditions which shall be equal, just, and humane. Liberia and Hayti are, as yet, the only countries to which colonists of African descent from here could go with certainty of being received and adopted as citizens; and I regret to say such persons, contemplating colonization, do not seem so willing to migrate to those countries as to some others, nor so willing as I think their interest demands. I believe, however, opinion among them in this respect is improving; and that ere long there will be an augmented and considerable migration to both these countries from the United States.

The new commercial treaty between the United States and the Sultan of Turkey has been carried into execution.

A commercial and consular treaty has been negotiated, subject to the Senate's consent, with Liberia; and a similar negotiation is now pending with the Republic of Hayti. A considerable improvement of the national commerce is expected to result from these measures.

Our relations with Great Britain, France, Spain, Portugal, Russia, Prussia, Denmark, Sweden, Austria, the Netherlands, Italy, Rome, and the other European states remain undisturbed. Very favorable relations also continue to be maintained with Turkey, Morocco, China, and Japan.

During the last year there has not only been no change of our previous relations with the Independent States of our own continent, but more friendly sentiments than have heretofore existed are believed to be entertained by these neighbors, whose safety and progress are so intimately connected with our own. This statement especially applies to Mexico, Nicaragua, Costa Rica, Honduras, Peru, and Chili.

The commission under the convention with the Republic of New Granada closed its session without having audited and passed upon all the claims which were submitted to it. A proposition is pending to revive the convention, that it may be able to do more complete justice. The joint commission between the United States and the Republic of Costa Rica has completed its labors and submitted its report.

I have favored the project for connecting the United States with Europe by an Atlantic telegraph, and a similar project to extend the telegraph from San Francisco to connect by a Pacific telegraph with the line which is being extended across the Russian Empire.

The Territories of the United States, with unimportant exceptions, have remained undisturbed by the civil war; and they are exhibiting such evidence of prosperity as justifies an expectation that some of them will soon be in a condition to be organized as States, and be constitutionally admitted into the Federal Union.

The immense mineral resources of some of those Territories ought to be developed as rapidly as possible. Every step in that direction would have a tendency to improve the revenues of the Government and diminish the burdens of the people. It is worthy of your serious consideration whether some extraordinary measures to promote that end cannot be adopted. The means which suggests itself as most likely to be effective, is a scientific exploration of the mineral regions in those Territories, with a view to the publication of its results at home and in foreign countries—results which cannot fail to be auspicious.

The condition of the finances will claim your most diligent consideration. The vast expenditures incident to the military and naval operations required for the suppression of the rebellion have been hitherto met with a promptitude and certainty unusual in similar circumstances; and the public credit has been fully maintained. The continuance of the war, however, and the increased disbursements made necessary by the augmented forces now in the field, demand your

best reflections as to the best modes of providing the necessary revenue, without injury to business, and with the least possible burdens upon labor.

The suspension of specific payments by the Banks, soon after the commencement of your last session, made large issues of United States notes unavoidable. In no other way could the payment of the troops, and the satisfaction of other just demands, be so economically or so well provided for. The judicious legislation of Congress, securing the receivability of these notes for loans and internal duties, and making them a legal tender for other debts, has made them a universal currency, and has satisfied partially at least, and for the time, the long felt want of an uniform circulating medium, saving thereby to the people immense sums in discounts and exchanges.

A return to specie payments, however, at the earliest period compatible with due regard to all interests concerned, should ever be kept in view. Fluctuations in the value of currency are always injurious, and to reduce these fluctuations to the lowest possible point will always be a leading purpose in wise legislation. Convertibility, prompt and certain convertibility into coin, is generally acknowledged to be the best and surest safeguard against them; and it is extremely doubtful whether a circulation of United States notes, payable in coin, and sufficiently large for the wants of the people, can be permanently, usefully, and safely maintained.

Is there, then, any other mode in which the necessary provision for the public wants can be made, and the great advantages of a safe and uniform currency secured?

I know of none which promises so certain results, and is, at the same time, so unobjectionable as the organization of banking associations, under a general act of Congress, well guarded in its provisions. To such associations the Government might furnish circulating notes, on the security of United States bonds deposited in the Treasury. These notes, prepared under the supervision of proper officers, being uniform in appearance and security, and convertible always into coin, would at once protect labor against the evils of a vicious currency, and facilitate commerce by cheap and safe exchanges.

A moderate reservation from the interest on the bonds would compensate the United States for the preparation and distribution of the notes, and a general supervision of the system, and would lighten the burden of that part of the public debt employed as securities. The public credit, moreover, would be greatly improved, and the negotiation of new loans greatly facilitated by the steady market demand for Government bonds which the adoption of the proposed system would create.

It is an additional recommendation of the measure, of considerable weight, in my judgment, that it would reconcile as far as possible all existing interests, by the opportunity offered to existing institutions to reorganize under the act, substituting only the secured uniform national circulation for the local and various circulation, secured and unsecured, now issued by them.

The receipts into the Treasury, from all sources, including loans, and balance from the preceding year, for the fiscal year ending on the 30th June, 1862, were \$583,885,247 06, of which sum \$48,056,397 62 were derived from customs; \$1,795,331 73 from the direct tax; from public lands, \$152,203 77; from miscellaneous sources, \$981,787 64; from loans in all forms, \$529,892,460 50. The remainder, \$2,257,065 80, was the balance from last year.

The disbursements during the same period were for Congressional, Executive, and Judicial purposes, \$5,939,009 29; for foreign intercourse, \$1,359,710 35; for miscellaneous expenses, including the mints, loans, post office deficiencies, collection of revenue, and other like charges, \$14,129,771 50; for expenses under the Interior Department, \$3,102,985 52; under the War Department, \$394,868,407 36; under the Navy Department, \$42,674,569 69; for interest on public

debt, \$18,190,824 45; and for payment of public debt, including reimbursement of temporary loan, and redemptions, \$96,096,922 09; making an aggregate of \$570,841,700 25, and leaving a balance in the Treasury on the 1st day of July, 1862, of \$18,048,546 81.

It should be observed that the sum of \$96,096,922 09, expended for reimbursements and redemption of public debt, being included also in the loans made, may be properly deducted, both from receipts and expenditures, leaving the actual receipts for the year \$487,788,324 97, and the expenditures, \$474,744,778 16.

Other information on the subject of the finances will be found in the report of the Secretary of the Treasury, to whose statements and views I invite your most candid and considerate attention.

The reports of the Secretaries of War and of the Navy are herewith transmitted. These reports, though lengthy, are scarcely more than brief abstracts of the very numerous and extensive transactions and operations conducted through those Departments. Nor could I give a summary of them here, upon any principle which would admit of its being much shorter than the reports themselves. I therefore content myself with laying the reports before you, and asking your attention to them.

It gives me pleasure to report a decided improvement in the financial condition of the Post Office Department, as compared with several preceding years. The receipts for the fiscal year 1861 amounted to \$3,849,296 40, which embraced the revenue from all the States of the Union for three quarters of that year. Notwithstanding the cessation of revenue from the so-called seceded States during the last fiscal year, the increase of the correspondence of the loyal States has been sufficient to produce a revenue during the same year of \$3,299,820 90, being only \$50,000 less than was derived from all the States of the Union during the previous year. The expenditures show a still more favorable result. The amount expended in 1861 was \$13,606,759 11. For the last year the amount has been reduced to \$11,125,364 13, showing a decrease of about \$2,481,000 in the expenditures as compared with the preceding year, and about \$3,750,000 as compared with the fiscal year 1860. The deficiency in the Department for the previous year was \$4,551,966 98. For the last fiscal year it was reduced to \$2,112,814 57. These favorable results are in part owing to the cessation of mail service in the insurrectionary States, and in part to a careful review of all expenditures in that department in the interest of economy. The efficiency of the postal service, it is believed, has also been much improved. The Postmaster General has also opened a correspondence, through the Department of State, with foreign Governments, proposing a convention of postal representatives for the purpose of simplifying the rates of foreign postage, and to expedite the foreign mails. This proposition, equally important to our adopted citizens and to the commercial interests of this country, has been favorably entertained and agreed to by all the Governments from whom replies have been received.

I ask the attention of Congress to the suggestions of the Postmaster General in his report respecting the further legislation required, in his opinion, for the benefit of the postal service.

The Secretary of the Interior reports as follows in regard to the public lands:

The public lands have ceased to be a source of revenue. From the 1st July, 1861, to the 30th September, 1862, the entire cash receipts from the sale of lands were \$187,476 26—a sum much less than the expenses of our land system during the same period. The homestead law, which will take effect on the 1st of January next, offers such inducements to settlers that sales for cash cannot be expected, to an extent sufficient to meet the expense of the General Land Office, and the cost of surveying and bringing the land into market.

The discrepancy between the sum here stated as arising from the sales of the public lands, and the sum derived from the same source as reported from the Treasury Department, arises, as I understand, from

the fact that the periods of time, though apparently, were not really coincident at the beginning point—the Treasury report including a considerable sum now which had previously been reported from the Interior—sufficiently large to greatly overreach the sum derived from the three months now reported upon by the Interior, and not by the Treasury.

The Indian tribes upon our frontiers have, during the past year, manifested a spirit of insubordination, and, at several points, have engaged in open hostilities against the white settlements in their vicinity. The tribes occupying the Indian country south of Kansas renounced their allegiance to the United States, and entered into treaties with the insurgents. Those who remained loyal to the United States were driven from the country. The chief of the Cherokees has visited this city for the purpose of restoring the former relations of the tribe with the United States. He alleges that they were constrained, by superior force, to enter into treaties with the insurgents, and that the United States neglected to furnish the protection which their treaty stipulations required.

In the month of August last, the Sioux Indians, in Minnesota, attacked the settlements in their vicinity with extreme ferocity, killing indiscriminately, men, women, and children. This attack was wholly unexpected, and therefore no means of defence had been provided. It is estimated that not less than eight hundred persons were killed by the Indians, and a large amount of property was destroyed. How this outbreak was induced is not definitely known, and suspicions, which may be unjust, need not to be stated. Information was received by the Indian Bureau, from different sources, about the time hostilities were commenced, that a simultaneous attack was to be made upon the white settlements by all the tribes between the Mississippi River and the Rocky Mountains. The State of Minnesota has suffered great injury from this Indian war. A large portion of her territory has been depopulated, and a severe loss has been sustained by the destruction of property. The people of that State manifest much anxiety for the removal of the tribes beyond the limits of the State as a guarantee against future hostilities. The Commissioner of Indian Affairs will furnish full details. I submit for your especial consideration whether our Indian system shall not be remodelled. Many wise and good men have impressed me with the belief that this can be profitably done.

I submit a statement of the proceedings of commissioners, which shows the progress that has been made in the enterprise of constructing the Pacific railroad. And this suggests the earliest completion of this road, and also the favorable action of Congress upon the projects now pending before them for enlarging the capacities of the great canals in New York and Illinois, as being of vital and rapidly increasing importance to the whole nation, and especially to the vast interior region hereinafter to be noticed at some greater length. I purpose having prepared and laid before you at an early day some interesting and valuable statistical information upon this subject. The military and commercial importance of enlarging the Illinois and Michigan canal, and improving the Illinois river, is presented in the report of Col. Webster to the Secretary of War, and now transmitted to Congress. I respectfully ask attention to it.

To carry out the provisions of the act of Congress of the 15th of May last, I have caused the Department of Agriculture of the United States to be organized.

The Commissioner informs me that within the period of a few months this department has established an extensive system of correspondence and exchanges, both at home and abroad, which promises to effect highly beneficial results in the development of a correct knowledge of recent improvements in agriculture, in the introduction of new products, and in the collection of the agricultural statistics of the different States. Also, that it will soon be prepared to distribute largely seeds, cereals, plants and cuttings, and has already published and liberally diffused much valuable in-

formation in anticipation of a more elaborate report, which will in due time be furnished, embracing some valuable tests in chemical science now in progress in the laboratory.

The creation of this department was for the more immediate benefit of a large class of our most valuable citizens; and I trust that the liberal basis upon which it has been organized will not only meet your approbation, but that it will realize, at no distant day, all the fondest anticipations of its most sanguine friends, and become the fruitful source of advantage to all our people.

On the 22d day of September last a proclamation was issued by the Executive, a copy of which is herewith submitted.

In accordance with the purpose expressed in the second paragraph of that paper, I now respectfully recall your attention to what may be called "compensated emancipation."

A nation may be said to consist of its territory, its people, and its laws. The territory is the only part which is of certain durability. "One generation passeth away and another generation cometh, but the earth abideth forever." It is of the first importance to duly consider and estimate this ever enduring part. That portion of the earth's surface which is owned and inhabited by the people of the United States is well adapted to the home of one national family; and it is not well adapted for two or more. Its vast extent and its variety of climate and productions are of advantage in this age for one people, whatever they might have been in former ages. Steams, telegraphs, and intelligence have brought these to be an advantageous combination for one united people.

In the Inaugural Address I briefly pointed out the total inadequacy of disunion as a remedy for the differences between the people of the two sections. I did so in language which I cannot improve, and which, therefore, I beg to repeat:

"One section of our country believes slavery is right, and ought to be extended, while the other believes it is wrong, and ought not to be extended. This is the only substantial dispute. The fugitive slave clause of the Constitution, and the law for the suppression of the foreign slave trade, are each as well enforced, perhaps, as any law can ever be in a community where the moral sense of the people imperfectly supports the law itself. The great body of the people abide by the dry legal obligation in both cases, and a few break over in each. This, I think, cannot be perfectly cured; and it would be worse in both cases after the separation of the sections than before. The foreign slave trade, now imperfectly suppressed, would be ultimately revived without restriction in one section; while fugitive slaves, now only partially surrendered, would not be surrendered at all by the other.

"Physically speaking, we cannot separate. We cannot remove our respective sections from each other, nor build an impassable wall between them. A husband and wife may be divorced and go out of the presence and beyond the reach of each other; but the different parts of our country cannot do this. They cannot but remain face to face; and intercourse, either amicable or hostile, must continue between them. Is it possible, then, to make that intercourse more advantageous or more satisfactory after separation than before? Can aliens make treaties easier than friends can make laws? Can treaties be more faithfully enforced between aliens than laws can among friends? Suppose you go to war, you cannot fight always; and when, after much loss on both sides, and no gain on the other, you cease fighting, the identical old questions, as to terms of intercourse, are again upon you."

There is no line, straight or crooked, suitable for a national boundary upon which to divide. Trace through, from east to west, upon the line between the free and slave country, and we shall find a little more than one third of its length are rivers, easy to be crossed, and populated, or soon to be populated, thickly upon both sides; while nearly all its remaining length are merely surveyors' lines, over which people may walk back and forth without any consciousness of their

presence. No part of this line can be made any more difficult to pass by writing it down on paper, or parchment, as a national boundary. The fact of separation, if it comes, gives up, on the part of the seceding section, the fugitive slave clause, along with all other constitutional obligations upon the section seceded from, while I should expect no treaty stipulation would ever be made to take its place.

But there is another difficulty. The great interior region, bounded east by the Alleghenies, north by the British dominions, west by the Rocky Mountains, and south by the line along which the culture of corn and cotton meets, and which includes part of Virginia, part of Tennessee, all of Kentucky, Ohio, Indiana, Michigan, Wisconsin, Illinois, Missouri, Kansas, Iowa, Minnesota, and the Territories of Dakota, Nebraska, and part of Colorado, already has above ten millions of people, and will have fifty millions within fifty years if not prevented by any political folly or mistake. It contains more than one third of the country owned by the United States—certainly more than one million of square miles. Once half as populous as Massachusetts already is it would have more than seventy-five millions of people. A glance at the map shows that, territorially speaking, it is the great body of the Republic. The other parts are but marginal borders to it, the magnificent region sloping west from the Rocky Mountains to the Pacific being the deepest and also the richest in undeveloped resources. In the production of provisions, grains, grasses, and all which proceed from them, this great interior region is naturally one of the most important of the world. Ascertain from the statistics the small proportion of the region which has as yet been brought into cultivation, and also the large and rapidly increasing amount of its products, and we shall be overwhelmed with the magnitude of the prospect presented. And yet this region has no seacoast, touches no ocean anywhere. As part of one nation, its people now find, and may forever find, their way to Europe by New York, to South America and Africa by New Orleans, and to Asia by San Francisco. But separate our common country into two nations, as designed by the present rebellion, and every man of this great interior region is thereby cut off from some one or more of these outlets, not perhaps by a physical barrier, but by embarrassing and onerous trade regulations.

And this is true, wherever a dividing or boundary line may be fixed. Place it between the now free and slave country, or place it south of Kentucky or north of Ohio, and still the truth remains that none south of it can trade to any port or place north of it, and none north of it can trade to any port or place south of it, except upon terms dictated by a Government foreign to them. These outlets, east, west, and south, are indispensable to the well-being of the people inhabiting and to inhabit this vast interior region. Which of the three may be the best is no proper question. All are better than either, and all of right belong to that people and to their successors forever. True, to themselves, they will not ask where a line of separation shall be, but will vow rather that there shall be no such line. Nor are the marginal regions less interested in these communications to and through them to the great outside world. They too, and each of them, must have access to this Egypt of the West, without paying toll at the crossing of any national boundary.

Our national strife springs not from our permanent part; not from the land we inhabit; not from our national homestead. There is no possible severing of this, but would multiply and not mitigate evils among us. In all its adaptations and aptitudes, it demands union and abhors separation. In fact it would ere long force reunion, however much of blood and treasure the separation might have cost.

Our strife pertains to ourselves—to the passing generations of men; and it can without convulsion be hushed forever with the passing of one generation.

In this view, I recommend the adoption of the following resolution and articles amendatory to the Constitution of the United States:

*Resolved by the Senate and House of Representatives of the United States of America in Congress assembled* (two thirds of both Houses concurring), That the following articles be proposed to the Legislatures (or Conventions) of the several States as amendments to the Constitution of the United States, all or any of which articles when ratified by three fourths of the said Legislatures (or Conventions) to be valid as part or parts of the said Constitution, viz.:

**ARTICLE** — Every State wherein slavery now exists which shall abolish the same therein at any time or times before the first day of January, in the year of our Lord one thousand and nine hundred, shall receive compensation from the United States, as follows, to wit:

The President of the United States shall deliver to every such State bonds of the United States, bearing interest at the rate of — per cent. per annum, to an amount equal to the aggregate sum of — for each slave shown to have been therein by the eighth census of the United States, said bonds to be delivered to such State by instalments, or in one parcel, at the completion of the abolishment, accordingly as the same shall have been gradual, or at one time, within such State; and interest shall begin to run upon any such bond only from the proper time of its delivery as aforesaid. Any State having received bonds as aforesaid, and afterward reintroducing or tolerating slavery therein, shall refund to the United States the bonds so received, or the value thereof, and all interest paid thereon.

**ARTICLE** — All slaves who shall have enjoyed actual freedom by the chances of the war, at any time before the end of the rebellion, shall be forever free; but all owners of such who shall not have been disloyal shall be compensated for them, at the same rates as is provided for States adopting abolishment of slavery, but in such way that no slave shall be twice accounted for.

**ARTICLE** — Congress may appropriate money, and otherwise provide, for colonizing free colored persons, with their own consent, at any place or places without the United States.

I beg indulgence to discuss these proposed articles at some length. Without slavery the rebellion could never have existed; without slavery it could not continue.

Among the friends of the Union there is great diversity of sentiment and of policy in regard to slavery, and the African race amongst us. Some would perpetuate slavery; some would abolish it suddenly and without compensation; some would abolish it gradually and with compensation; some would remove the freed people from us, and some would retain them with us; and there are yet other minor diversities. Because of these diversities we waste much strength in struggles among ourselves. By mutual concession we should harmonize and act together. This would be compromise; but it would be compromise among the friends and not with the enemies of the Union. These articles are intended to embody a plan of such mutual concessions. If the plan shall be adopted, it is assumed that emancipation will follow at least in several of the States.

As to the first article the main points are: first, the emancipation; secondly, the length of time for consummating it—thirty-seven years; and, thirdly, the compensation.

The emancipation will be unsatisfactory to the advocates of perpetual slavery; but the length of time should greatly mitigate their dissatisfaction. The time spares both races from the evils of sudden derangement—in fact from the necessity of any derangement—while most of those whose habitual course of thought will be disturbed by the measure will have passed away before its consummation. They will never see it. Another class will hail the prospect of emancipation, but will deprecate the length of time. They will feel that it gives too little to the now living slaves. But it really gives them much. It saves them from the vagrant destitution which must largely attend immediate emancipation in localities where their numbers are very great; and it gives the inspiring assurance that their posterity shall be free forever. The plan leaves to each State choosing to act under it to abolish slavery now or at the end of the century, or at any intermediate time, or by degrees, extending over the whole or any part of the period; and it obliges no two States to proceed alike. It also provides for compensation, and generally the mode of making it. This, it would seem,

must further mitigate the dissatisfaction of those who favor perpetual slavery, and especially of those who are to receive the compensation. Doubtless some of those who are to pay and not to receive will object. Yet the measure is both just and economical. In a certain sense, the liberation of slaves is the destruction of property—property acquired by descent or by purchase, the same as any other property. It is no less true for having been often said, that the people of the South are not more responsible for the original introduction of this property than are the people of the North; and when it is remembered how unhesitatingly we all use cotton and sugar, and share the profits of dealing in them, it may not be quite safe to say that the South has been more responsible than the North for its continuance. If, then, for a common object this property is to be sacrificed, is it not just that it be done at a common charge?

And if with less money, or money more easily paid, we can preserve the benefits of the Union by this means than we can by the war alone, is it not also economical to do it? Let us consider it, then. Let us ascertain the sum we have expended in the war since compensated emancipation was proposed last March, and consider whether, if that measure had been promptly accepted by even some of the Slave States, the same sum would not have done more to close the war than has been otherwise done. If so, the measure would save money, and, in that view, would be a prudent and economical measure. Certainly it is not so easy to pay something as it is to pay nothing; but it is easier to pay a large sum than it is to pay a larger one. And it is easier to pay any sum when we are able than it is to pay it before we are able. The war requires large sums, and requires them at once. The aggregate sum necessary for compensated emancipation of course would be large. But it would require no ready cash, nor the bonds even, any faster than the emancipation progresses. This might not, and probably would not, close before the end of the thirty-seven years. At that time we shall probably have a hundred millions of people to share the burden, instead of thirty-one millions, as now. And not only so, but the increase of our population may be expected to continue for a long time after that period as rapidly as before; because our territory will not have become full. I do not state this inconsiderately.

At the same ratio of increase which we have maintained, on an average, from our first national census, in 1790, until that of 1860, we should, in 1800, have a population of 103,208,415. And why may we not continue that ratio far beyond that period? Our abundant room—our broad national homestead—is our ample resource. Were our territory as limited as are the British Isles, very certainly our population could not expand as stated. Instead of receiving the foreign born as now, we should be compelled to send part of the native born away. But such is not our condition. We have two millions nine hundred and sixty-three thousand square miles. Europe has three millions and eight hundred thousand, with a population averaging seventy-three and one third persons to the square mile. Why may not our country at some time average as many? Is it less fertile? Has it more waste surface, by mountains, rivers, lakes, deserts, or other causes? Is it inferior to Europe in any natural advantage? If then we are, at some time, to be as populous as Europe, how soon? As to when this may be, we can judge by the past and the present; as to when it will be, if ever, depends much on whether we maintain the Union. Several of our States are already above the average of Europe—seventy-three and a third to the square mile. Massachusetts has 157; Rhode Island 183; Connecticut 99; New York and New Jersey, each 80. Also two other great States, Pennsylvania and Ohio, are not far below, the former having 63 and the latter 59. The States already above the European average, except New York, have increased in as rapid a ratio, since passing that point, as ever before; while no one of them is equal to some other parts of our country in natural capacity for sustaining a dense population.

Taking the nation in the aggregate, and we find its population and ratio of increase, for the several decennial periods, to be as follows:

1790....	3,929,827			
1800....	5,305,937	35.03	per cent. ratio of increase.	
1810....	7,289,914	36.45	"	"
1820....	9,688,181	33.18	"	"
1830....	12,866,020	33.49	"	"
1840....	17,069,458	32.67	"	"
1850....	23,191,876	35.87	"	"
1860....	31,448,790	35.56	"	"

This shows an average decennial increase of 34.60 per cent. in population through the seventy years, from our first to our last census yet taken. It is seen that the ratio of increase, at no one of these two periods, is either two per cent. below or two per cent. above the average; thus showing how inflexible, and consequently how reliable, the law of increase in our case is. Assuming that it will continue, it gives the following results:

1870.....	42,823,841
1880.....	56,967,216
1890.....	76,677,872
1900.....	108,308,415
1910.....	139,918,526
1920.....	184,984,885
1930.....	251,680,914

These figures show that our country may be as populous as Europe now is at some point between 1920 and 1930—say about 1925—our territory, at seventy-three and a third persons to the square mile, being of capacity to contain 217,186,000

And we will reach this, too, if we do not ourselves relinquish the chance, by the folly and evils of disunion, or by long and exhausting wars springing from the only great element of national discord among us. While it cannot be foreseen exactly how much one huge example of secession, breeding lesser ones indefinitely, would retard population, civilization, and prosperity, no one can doubt that the extent of it would be very great and injurious.

The proposed emancipation would shorten the war, perpetuate peace, insure this increase of population, and proportionately the wealth of the country. With these, we should pay all the emancipation would cost, together with our other debt, easier than we should pay our other debt without it. If we had allowed our old national debt to run at six per cent. per annum, simple interest, from the end of our Revolutionary struggle until to-day, without paying anything on either principal or interest, each man of us would owe less upon that debt now than each man owed upon it then; and this because our increase of men, through the whole period, has been greater than six per cent.; has run faster than the interest upon the debt. Thus, time alone relieves a debtor nation, so long as its population increases faster than unpaid interest accumulates on its debt.

This fact would be no excuse for delaying payment of what is justly due; but it shows the great importance of time in this connection—the great advantage of a policy by which we shall not have to pay until we number a hundred millions, what, by a different policy, we would have to pay now, when we number but thirty-one millions. In a word, it shows that a dollar will be much harder to pay for the war than will be a dollar for the emancipation on the proposed plan. And then the latter will cost no blood, no precious life. It will be a saving of both.

As to the second article, I think it would be impracticable to return to bondage the class of persons therein contemplated. Some of them, doubtless, in the property sense, belong to loyal owners; and hence provision is made in this article for compensating such. The third article relates to the future of the freed people. It does not oblige, but merely authorizes Congress to aid in colonizing such as may consent. This ought not to be regarded as objectionable on the one hand or the other, in so much as it comes to nothing unless by the mutual consent of the people to be deported, and the American voters, through their representatives in Congress.

I cannot make it better known than it already is that I strongly favor colonization. And yet I wish to say there is an objection urged against free colored persons remaining in the country which is largely imaginary, if not sometimes malicious.

It is insisted that their presence would injure and displace white labor and white laborers. If there ever could be a proper time for mere catch arguments, that time surely is not now. In times like the present men should utter nothing for which they would not willingly be responsible through time and in eternity. Is it true, then, that colored people can displace any more white labor by being free than by remaining slaves? If they stay in their old places they jostle no white laborers; if they leave their old places they leave them open to white laborers. Logically, there is neither more nor less of it. Emancipation even without deportation, would probably enhance the wages of white labor, and, very surely, would not reduce them. Thus the customary amount of labor would still have to be performed—the freed people would surely not do more than their old proportion of it, and very probably for a time would do less, leaving an increased part to white laborers, bringing their labor into greater demand, and consequently enhancing the wages of it. With deportation, even to a limited extent, enhanced wages to white labor is mathematically certain. Labor is like any other commodity in the market—increase the demand for it and you increase the price of it. Reduce the supply of black labor, by colonizing the black laborer out of the country, and by precisely so much you increase the demand for and wages of white labor.

But it is dreaded that the freed people will swarm forth and cover the whole land! Are they not already in the land? Will liberation make them any more numerous? Equally distributed among the whites of the whole country, and there would be but one colored to seven whites. Could the one, in any way, greatly disturb the seven? There are many communities now having more than one free colored person to seven whites; and this, without any apparent consciousness of evil from it. The District of Columbia and the States of Maryland and Delaware are all in this condition. The District has more than one free colored to six whites; and yet, in its frequent petitions to Congress, I believe it has never presented the presence of free colored persons as one of its grievances. But why should emancipation South send the freed people North? People of any color seldom run unless there be something to run from. Heretofore colored people to some extent have fled North from bondage; and now, perhaps, from bondage and destitution. But if gradual emancipation and deportation be adopted they will have neither to flee from. Their old masters will give them wages at least until new laborers can be procured, and the freed men in turn will gladly give their labor for the wages till new homes can be found for them in congenial climes and with people of their own blood and race. This proposition can be trusted on the mutual interests involved. And in any event, cannot the North decide for itself whether to receive them?

Again, as practice proves more than theory, in any case, has there been any irruption of colored people northward because of the abolishment of slavery in this District last spring?

What I have said of the proportion of free colored persons to the whites in the District is from the census of 1860, having no reference to persons called contrabands, nor to those made free by the act of Congress abolishing slavery here.

The plan consisting of these articles is recommended, not but that a restoration of national authority would be accepted without its adoption.

Nor will the war, nor proceedings under the proclamation of September 22, 1862, be stayed because of the recommendation of this plan. Its timely adoption, I doubt not, would bring restoration, and thereby stay both.

And, notwithstanding this plan, the recommendation that Congress provide by law for compensating any State which may adopt emancipation before this plan



shall have been acted upon, is hereby earnestly renewed. Such would be only an advance part of the plan, and the same arguments apply to both.

This plan is recommended as a means, not in exclusion of, but additional to, all others for restoring and preserving the national authority throughout the Union. The subject is presented exclusively in its economical aspect. The plan would, I am confident, secure peace more speedily, and maintain it more permanently, than can be done by force alone; while all it would cost, considering amounts, and manner of payment, and times of payment, would be easier paid than will be the additional cost of the war, if we rely solely upon force. It is much—very much—that it would cost no blood at all.

The plan is proposed as permanent constitutional law. It cannot become such without the concurrence of, first, two-thirds of Congress, and afterward three-fourths of the States. The requisite three-fourths of the States will necessarily include seven of the Slave States. Their concurrence, if obtained, will give assurance of their severally adopting emancipation, at no very distant day, upon the new constitutional terms. This assurance would end the struggle now, and save the Union forever.

I do not forget the gravity which should characterize a paper addressed to the Congress of the nation by the Chief Magistrate of the nation. Nor do I forget that some of you are my seniors; nor that many of you have more experience than I in the conduct of public affairs. Yet I trust that, in view of the great responsibility resting upon me, you will perceive no want of respect to yourselves in any undue earnestness I may seem to display.

Is it doubted, then, that the plan I propose, if adopted, would shorten the war, and thus lessen its expenditure of money and of blood? Is it doubted that it would restore the national authority and national prosperity, and perpetuate both indefinitely? Is it doubted that we here—Congress and Executive—can secure its adoption? Will not the good people respond to a united and earnest appeal from us? Can we, can they, by any other means, so certainly or so speedily assure these vital objects? We can succeed only by concert. It is not "can any of us imagine better?" but "can we all do better?" Object whatsoever is possible, still the question recurs, "can we do better?" The dogmas of the quiet past are inadequate to the stormy present. The occasion is piled high with difficulty, and we must rise with the occasion. As our case is new, so we must think anew, and act anew. We must disenthrall ourselves, and then we shall save our country.

Fellow citizens, we cannot escape history. We of this Congress and this Administration will be remembered in spite of ourselves. No personal significance or insignificance can spare one or another of us. The fiery trial through which we pass will light us down in honor or dishonor to the latest generation. We say we are for the Union. The world will not forget that we say this. We know how to save the Union. The world knows we do know how to save it. We—even we here—hold the power and bear the responsibility. In giving freedom to the slave we assure freedom to the free—honorable alike in what we give and what we preserve. We shall nobly save or meanly lose the last best hope of earth. Other means may succeed; this could not fail. The way is plain, peaceful, generous, just—a way which, if followed, the world will forever applaud and God must forever bless.

DECEMBER 1, 1862. ABRAHAM LINCOLN.

*Inaugural Address of JEFFERSON DAVIS on entering upon his duties as President of the Confederate States under the "Permanent Constitution," Feb. 22, 1862.*

FELLOW CITIZENS: On this the birthday of the man most identified with the establishment of American independence, and beneath the monument erected to

commemorate his heroic virtues and those of his compatriots, we have assembled to usher into existence the permanent Government of the Confederate States. Through this instrumentality, under the favor of Divine Providence, we hope to perpetuate the principles of our Revolutionary fathers. The day, the memory, and the purpose seem fitly associated.

It is with mingled feelings of humility and pride that I appear to take, in the presence of the people and before high Heaven, the oath prescribed as a qualification for the exalted station to which the unanimous voice of the people has called me. Deeply sensible of all that is implied by this manifestation of the people's confidence, I am yet more profoundly impressed by the vast responsibility of the office, and humbly feel my own unworthiness.

In return for their kindness I can only offer assurances of the gratitude with which it is received, and can but pledge a zealous devotion of every faculty to the service of those who have chosen me as their Chief Magistrate.

When a long course of class legislation, directed not to the general welfare but to the aggrandizement of the Northern section of the Union, culminated in a warfare on the domestic institutions of the Southern States—when the dogmas of a sectional party, substituted for the provisions of the constitutional compact, threatened to destroy the sovereign rights of the States, six of those States, withdrawing from the Union, confederated together to exercise the right and perform the duty of instituting a Government which would better secure the liberties for the preservation of which that Union was established.

Whatever of hope some may have entertained that a returning sense of justice would remove the danger with which our rights were threatened, and render it possible to preserve the Union of the Constitution, must have been dispelled by the malignity and barbarity of the Northern States in the prosecution of the existing war. The confidence of the most hopeful among us must have been destroyed by the disregard they have recently exhibited for all the time-honored bulwarks of civil and religious liberty. Bastilles filled with prisoners, arrested without civil process or indictment duly found; the writ of habeas corpus suspended by Executive mandate; a State Legislature controlled by the imprisonment of members whose avowed principles suggested to the Federal Executive that there might be another added to the list of Seceded States; elections held under threats of a military power; civil officers, peaceful citizens, and gentle women incarcerated for opinion's sake, proclaimed the incapacity of our late associates to administer a Government as free, liberal, and humane as that established for our common use.

For proof of the sincerity of our purpose to maintain our ancient institutions we may point to the Constitution of the Confederacy and the laws enacted under it, as well as to the fact that through all the necessities of an unequal struggle there has been no act on our part to impair personal liberty, or the freedom of speech, of thought, or of the press. The courts have been open, the judicial functions fully executed, and every right of the peaceful citizen maintained as securely as if a war of invasion had not disturbed the land.

The people of the States now confederated became convinced that the Government of the United States had fallen into the hands of a sectional majority, who would pervert that most sacred of all trusts to the destruction of the rights which it was pledged to protect. They believed that to remain longer in the Union would subject them to a continuance of disparaging discrimination, submission to which would be inconsistent with their welfare, and intolerable to a proud people. They therefore determined to sever its bonds and establish a new Confederacy for themselves.

The experiment instituted by our Revolutionary fathers, of a voluntary union of sovereign States for purposes specified in a solemn compact, had been perverted by those who, feeling power and forgetting

right, were determined to respect no law but their own will. The Government had ceased to answer the ends for which it was ordained and established. To save ourselves from a revolution which, in its silent and rapid progress, was about to place us under the despotism of numbers, and to preserve in spirit, as well as in form, a system of government we believed to be peculiarly fitted to our condition, and full of promise to mankind, we determined to make a new association, composed of States homogeneous in interest, in policy, and in feeling.

True to our traditions of peace and our love of justice, we sent Commissioners to the United States to propose a fair and amicable settlement of all questions of public debt or property which might be in dispute. But the Government at Washington, denying our rights to self-government, refused even to listen to any proposals for a peaceful separation. Nothing was then left to us but to prepare for war.

The first year in our history has been the most eventful in the annals of this continent. A new Government has been established, and its machinery put in operation over an area exceeding seven hundred thousand square miles. The great principles upon which we have been willing to hazard everything that is dear to man, have made conquests for us which could never have been achieved by the sword. Our confederacy has grown from six to thirteen States, and Maryland, already united to us by hallowed memories and material interests, will, I believe, when able to speak with unsoftened voice, connect her destiny with the South. Our people have rallied with unexampled unanimity to the support of the great principles of constitutional government, with firm resolve to perpetuate by arms the rights which they could not peacefully secure. A million of men, it is estimated, are now standing in hostile array and waging war along a frontier of thousands of miles. Battles have been fought, sieges have been conducted, and although the contest is not ended, and the tide for the moment is against us, the final result in our favor is not doubtful.

The period is near at hand when our foes must sink under the immense load of debt which they have incurred—a debt which in their effort to subjugate us has already attained such fearful dimensions as will subject them to burdens which must continue to oppress them for generations to come.

We, too, have had our trials and difficulties. That we are to escape them in the future is not to be hoped. It was to be expected when we entered upon this war that it would expose our people to sacrifices and cost them much, both of money and blood. But we knew the value of the object for which we struggled, and understood the nature of the war in which we were engaged. Nothing could be so bad a failure, and any sacrifice would be cheap as the price of success in such a contest.

But the picture has its lights as well as its shadows. This great strife has awakened in the people the highest emotions and qualities of the human soul. It is cultivating feelings of patriotism, virtue, and courage. Instances of self-sacrifice and of generous devotion to the noble cause for which we are contending are rife throughout the land. Never has a people evinced a more determined spirit than that now animating men, women, and children in every part of our country. Upon the first call the men fly to arms; and wives and mothers send their husbands and sons to battle without a murmur of regret.

It was perhaps in the ordination of Providence that we were to be taught the value of our liberties by the price which we pay for them.

The recollections of this great contest, with all its common traditions of glory, of sacrifice, and of blood, will be the bond of harmony and enduring affection among the people, producing unity in policy, fraternity in sentiment, and joint effort in war.

Nor have the material sacrifices of the past been made without some corresponding benefits. If the acquiescence of foreign nations in a pretended blockade has

deprived us of our commerce with them, it is fast making us a self-supporting and an independent people. The blockade, if effectual and permanent, could only serve to divert our industry from the production of articles for export, and employ it in supplying commodities for domestic use.

It is a satisfaction that we have maintained the war by our unaided exertions. We have neither asked nor received assistance from any quarter. Yet the interest involved is not wholly our own. The world at large is concerned in opening our markets to its commerce. When the independence of the Confederate States is recognized by the nations of the earth, and we are free to follow our interests and inclinations by cultivating foreign trade, the Southern States will offer to manufacturing nations the most favorable markets which ever invited their commerce. Cotton, sugar, rice, tobacco, provisions, timber, and naval stores will furnish attractive exchanges. Nor would the constancy of those supplies be likely to be disturbed by war. Our confederate strength will be too great to tempt aggression; and never was there a people whose interests and principles committed them so fully to a peaceful policy as those of the Confederate States. By the character of their productions they are too deeply interested in foreign commerce wantonly to disturb it. War of conquest they cannot wage, because the constitution of their Confederacy admits of no coerced association. Civil war there cannot be between States held together by their volition only. This rule of voluntary association, which cannot fail to be conservative, by securing just and impartial government at home, does not diminish the security of the obligation by which the Confederate States may be bound to foreign nations. In proof of this it is to be remembered that, at the first moment of asserting their right of secession, these States proposed a settlement on the basis of a common liability for the obligations of the General Government.

Fellow citizens, after the struggles of ages had consecrated the right of the Englishman to constitutional representative Government, our Colonial ancestors were forced to vindicate that birthright by an appeal to arms. Success crowned their efforts, and they provided for their posterity a peaceful remedy against future aggression. The tyranny of an unbridled majority, the most odious and least responsible form of despotism, has denied us both the right and the remedy. Therefore we are in arms to renew such sacrifices as our fathers made to the holy cause of constitutional liberty. At the darkest hour of our struggle the provisional gives place to the permanent Government. After a series of successes and victories, which covered our arms with glory, we have recently met with serious disaster. But in the heart of a people resolved to be free, these disasters tend but to stimulate to increased resistance. To show ourselves worthy of the inheritance bequeathed to us by the patriots of the Revolution, we must emulate that heroic devotion which made reverse to them but the crucible in which their patriotism was refined.

With confidence in the wisdom and virtue of those who will share with me the responsibility and aid me in the conduct of public affairs; securely relying on the patriotism and courage of the people, of which the present war has furnished so many examples, I deeply feel the weight of the responsibilities I now, with unaffected diffidence, am about to assume; and, fully realizing the inadequacy of human power to guide and sustain, my hope is reverently fixed on Him whose favor is ever vouchsafed to the cause which is just. With humble gratitude and adoration, acknowledging the Providence which has so visibly protected the Confederacy during its brief but eventful career, to Thee, O God, I trustingly commit myself, and prayerfully invoke Thy blessing on my country and its cause.

JEFFERSON DAVIS.

*Message of President DAVIS to the Confederate Congress at its first Session under the "Permanent Constitution," Feb. 28, 1862.*

*To the Senate and House of Representatives of the Confederate States:*

In obedience to the constitutional provision requiring the President from time to time to give to Congress information of the state of the Confederacy, and recommend to their consideration such measures as he shall judge necessary and expedient, I have to communicate that, since my Message at the last session of the Provisional Congress, events have demonstrated that the Government had attempted more than it had power successfully to achieve. Hence in the effort to protect by our arms the whole territory of the Confederate States, seaboard and inland, we have been so exposed as recently to encounter serious disasters.

When the Confederacy was formed the States comprising it were, in the peculiar character of their pursuits and a misplaced confidence in their former associates, to a great extent destitute of the means for the prosecution of the war on so gigantic a scale as that which it has attained. The workshops and artists were mainly to be found in the Northern States, and one of the first duties which devolved upon this Government was to establish the necessary manufactories, and in the mean time to obtain, by purchase from abroad, as far as practicable, whatever was required for the public defence. No effort has been spared to effect both these ends, and, though the results have not equalled our hopes, it is believed that an impartial judgment will, upon full investigation, award to the various departments of the Government credit for having done all which human power and foresight enabled them to accomplish. The valor and devotion of the people have not only sustained the efforts of the Government, but have gone far to support its deficiencies.

The active state of military preparations among the nations of Europe in April last, the date when our agents first went abroad, interposed unavoidable delays in the procurement of arms, and the want of a navy has greatly impeded our efforts to import military supplies of all sorts.

I have hoped for several days to receive official reports in relation to our discomfiture at Roanoke Island and the fall of Fort Donelson. They have not yet reached me, and I am, therefore, unable to communicate to you such information of the late events and the consequences resulting from them as would enable me to make recommendations founded upon the changed condition which they have produced. Enough is known of the surrender of Roanoke Island to make us feel that it was deeply humiliating, however imperfect may have been the preparations for defence. The hope is still entertained that our reported losses at Fort Donelson have been greatly exaggerated, inasmuch as I am not only unwilling but unable to believe that a large army of our people have surrendered without a desperate effort to cut their way through the investing forces, whatever may have been their numbers, and to endeavor to make a junction with other divisions of the army. But, in the absence of that exact information which can only be afforded by official reports, it would be premature to pass judgment, and my own is reserved, as I trust yours will be, until that information is received.

In the mean time, strenuous efforts have been made to throw forward reinforcements to the armies at the positions threatened, and I cannot doubt that the bitter disappointments we have borne, by nerving the people to still greater exertions, will speedily secure results more accordant with our just expectations, and as favorable to our cause as those which marked the earlier periods of the war.

The reports of the Secretaries of War and Navy will exhibit the mass of resources for the conduct of the war which we have been enabled to accumulate, notwithstanding the very serious difficulties against which we have contended. They afford cheering hope that

our resources, limited as they were at the beginning of the contest, will, during its progress, become developed to such an extent as fully to meet our future wants.

The policy of enlistment for short terms, against which I have steadily contended from the commencement of the war, has, in my judgment, contributed in no immaterial degree to the recent reverses which we have suffered, and even now renders it difficult to furnish you an accurate statement of the army. When the war first broke out many of our people could with difficulty be persuaded that it would be long or serious. It was not deemed possible that anything so insane as a persistent attempt to subjugate these States could be made; still less that the delusion would so far prevail as to give to the war the vast proportions which it has assumed. The people, incredulous of a long war, were naturally averse to long enlistments, and the early legislation of Congress rendered it impracticable to obtain volunteers for a greater period than twelve months. Now that it has become probable that the war will be continued through a series of years, our high-spirited and gallant soldiers, while generally re-enlisting, are, from the fact of having entered the service for a short term, compelled, in many instances, to go home to make the necessary arrangements for their families during their prolonged absence.

The quotas of new regiments for the war, called for from the different States, are in rapid progress of organization. The whole body of new levies and re-enlisted men will probably be ready in the ranks within the next thirty days. But in the mean time it is exceedingly difficult to give an accurate statement of the number of our forces in the field. They may in general terms be stated at four hundred regiments of infantry, with a proportionate force of cavalry and artillery, the details of which will be shown by the report of the Secretary of War. I deem it proper to advert to the fact that the process of furloughs and re-enlistments in progress for the last month had so far disorganized and weakened our forces as to impair our ability for successful defence; but I heartily congratulate you that this evil, which I had foreseen and was powerless to prevent, may now be said to be substantially at an end, and that we shall not again during the war be exposed to seeing our strength diminished by this fruitful cause of disaster—short enlistments.

The people of the Confederate States, being principally engaged in agricultural pursuits, were unprovided at the commencement of hostilities with ships, ship yards, materials for ship building, or skilled mechanics and seamen in sufficient numbers to make the prompt creation of a navy a practical task, even if the required appropriations had been made for the purpose. Notwithstanding our very limited resources, however, the report of the Secretary will exhibit to you a satisfactory proportion in preparation, and certainty of early completion of vessels of a number and class on which we may confidently rely for testing the vaunted control of the enemy over our waters.

The financial system devised by the wisdom of your predecessors has proved adequate to supplying all the wants of the Government, notwithstanding the unexpected and very large increase of expenditures resulting from the great augmentation in the necessary means of defence. The report of the Secretary of the Treasury will exhibit the gratifying fact that we have no floating debt; that the credit of the Government is unimpaired; and that the total expenditure of the Government for the year has been, in round numbers, one hundred and seventy millions of dollars—less than one-third of the sum wasted by the enemy in his vain effort to conquer us; less than the value of a single article of export—the cotton crop of the year.

The report of the Postmaster-General will show the condition of that Department to be steadily improving, its revenues increasing, and already affording the assurance that it will be self-sustaining at the date required by the Constitution, while affording ample facilities for the people.

In the Department of Justice, which includes the

Patent Office and Public Printing, some legislative provision will be required, which will be specifically stated in the report of the head of that department. I invite the attention of Congress to the duty of organizing a Supreme Court of the Confederate States, in accordance with the mandate of the Constitution.

I refer you to my Message, communicated to the Provisional Congress in November last, for such further information touching the condition of public affairs as it might be useful to lay before you, the short interval which has since elapsed not having produced any material changes in that condition other than those to which reference has already been made.

In conclusion, I cordially welcome representatives who, recently chosen by the people, are fully imbued with their views and feelings, and can so ably advise me as to the needful provisions for the public service. I assure you of my hearty cooperation in all your efforts for the common welfare of the country.

JEFFERSON DAVIS.

*Message of President DAVIS at the second or adjourned Session of the Confederate Congress*  
—August 15, 1862.

*To the Senate and House of Representatives of the Confederate States:*

It is again our fortune to meet for devising measures necessary for the public welfare, whilst our country is involved in a desolating war. The sufferings endured by some portions of the people excite the deepest solicitude of the Government, and the sympathy thus evoked has been heightened by the patriotic devotion with which these sufferings have been borne. The gallantry and good conduct of our troops, always claiming the gratitude of the country, have been further illustrated on hard-fought fields, marked by exhibitions of individual prowess which can find but few parallels in ancient or modern history. Our army has not faltered in any of the various trials to which it has been subjected, and the great body of the people have continued to manifest a zeal and unanimity which not only cheer the battle-stained soldier, but give assurance to the friends of constitutional liberty of our final triumph in the pending struggle against despotic usurpation. The vast army which threatened the capital of the Confederacy has been defeated and driven from the lines of investment, and the enemy, repeatedly foiled in his efforts for its capture, is now seeking to raise new armies on a scale such as modern history does not record to effect that subjugation of the South so often proclaimed as on the eve of accomplishment.

The perfidy which disregarded rights secured by compact, the madness which trampled on obligations made sacred by every consideration of honor, have been intensified by the malignity engendered by defeat. These passions have changed the character of the hostilities waged by our enemies, who are becoming daily less regardful of the usages of civilized war and the dictates of humanity. Rapine and wanton destruction of private property, war upon non-combatants, murder of captives, bloody threats to avenge the death of an invading soldiery by the slaughter of unarmed citizens, orders of banishment against peaceful farmers engaged in the cultivation of the soil, are some of the means used by our ruthless invaders to enforce the submission of a free people to foreign sway. Confiscation bills of a character so atrocious as to insure, if executed, the utter ruin of the entire population of these States, are passed by their Congress and approved by their Executive. The moneyed obligations of the Confederate Government are forged by citizens of the United States, and publicly advertised for sale in their cities with a notoriety that sufficiently attests the knowledge of their Government, and its complicity in the crime is further evinced by the fact that the soldiers of the invading armies are found supplied with large quantities of these forged notes as a means of despoiling the country people, by fraud, out of such portions of their property as armed violence may fail to reach. Two,

at least, of the generals of the United States are engaged, unchecked by their Government, in exciting servile insurrection, and in arming and training slaves for warfare against their masters, citizens of the Confederacy. Another has been found of instincts so brutal as to invite the violence of his soldiery against the women of a captured city.

Yet, the rebuke of civilized men has failed to evoke from the authorities of the United States one mark of disapprobation of its acts; nor is there any reason to suppose that the conduct of Benjamin F. Butler has failed to secure from his Government the sanction and applause with which it is known to have been greeted by public meetings and portions of the press of the United States. To inquiries made of the Commander-in-Chief of the armies of the United States, whether the atrocious conduct of some of their military commandants met the sanction of that Government, answer has been evaded on the pretext that the inquiry was insulting, and no method remains for the suppression of these enormities but such retributive justice as it may be found possible to execute. Retaliation in kind for many of them is impracticable, for I have had occasion to remark in a former Message, that under no excess of provocation could our noble-hearted defenders be driven to wreak vengeance on unarmed men, on women, or on children. But stern and exemplary punishment can and must be meted out to the murderers and felons, who, disgracing the profession of arms, seek to make of public war the occasion for the commission of the most monstrous crimes. Deeply as we regret the character of the contest into which we are about to be forced, we must accept it as an alternative which recent manifestations give us little hope can be avoided. The exasperation of failure has aroused the worst passions of our enemies, a large portion of their people, even of their clergymen, now engage in urging an excited populace to the extreme of ferocity, and nothing remains but to vindicate our rights and to maintain our existence by employing against our foe every energy and every resource at our disposal.

I append for your information a copy of the paper exhibiting the action of the Government, up to the present time, for the repression of the outrages committed on our people. Other measures, now in progress, will be submitted hereafter. In inviting your attention to the legislation which the necessities of our condition require, those connected with the prosecution of the war command almost undivided attention.

The acts passed at your last session intended to secure the public defence by general enrolment, and to render uniform the rule governing troops in the service, have led to some unexpected criticism that is much to be regretted. The efficiency of the law has been thus somewhat impaired, though it is not believed that in any of the States the popular mind has withheld its sanction from either the necessity or propriety of your legislation. It is only by harmonious as well as zealous action, that a Government as new as ours, ushered into existence on the very eve of a great war, and unprovided with the material necessary for conducting hostilities on so vast a scale, can fulfil its duties. Upon you, who are fully informed of the acts and purposes of the Government, and thoroughly imbued with the feelings and sentiments of the people, must reliance be placed to secure this great object. You can best devise the means for establishing that cooperation of the State and Confederate Governments which is essential to the well-being of both at all times, but which is now indispensable to their very existence. And if any legislation shall seem to you appropriate for adjusting differences of opinion, it will be my pleasure as well as duty to cooperate in any measures that may be devised for reconciling a just care for the public defence with a proper deference for the most scrupulous susceptibilities of the State authorities.

The report of the Secretary of the Treasury will exhibit in detail the operations of that department. It will be seen with satisfaction that the credit of the Government securities remains unimpaired, and that

this credit is fully justified by the comparatively small amount of accumulated debt, notwithstanding the magnitude of our military operations. The legislation of the last session provided for the purchase of supplies with the bonds of the Government, but the preference of the people for Treasury notes has been so marked that the legislation is recommended to authorize an increase in the issue of Treasury notes, which the public service seems to require. No grave inconvenience need be apprehended from this increased issue, as the provision of law by which these notes are convertible into eight per cent. bonds, forms an efficient and permanent safeguard against any serious depreciation of the currency. Your attention is also invited to the means proposed by the Secretary for facilitating the preparation of these notes, and for guarding them against forgery. It is due to our people to state that the manufacture of counterfeit notes exists within our limits, and that they are imported also from the Northern States.

The report of the Secretary of War, which is submitted, contains numerous suggestions for the legislation deemed desirable in order to add to the efficiency of the service. I invite your favorable consideration especially to those recommendations which are intended to secure the proper execution of the conscript law, and the consolidation of companies, battalions, and regiments, when so reduced in strength as to impair that uniformity of organization which is necessary in the army, while an undue burden is imposed on the Treasury. The necessity for some legislation for controlling military transportation on the railroads, and improving their present defective condition, forces itself upon the attention of the Government, and I trust that you will be able to devise satisfactory measures for attaining this purpose. The legislation on the subject of general officers involves the service in some difficulties which are pointed out by the Secretary, and for which the remedy suggested by him seems appropriate.

In connection with this subject I am of opinion that prudence dictates some provision for the increase of the army, in the event of emergencies not now anticipated. The very large increase of force recently called into the field by the President of the United States may render it necessary hereafter to extend the provisions of the conscript law, so as to embrace persons between the age of thirty-five and forty-five years. The vigor and efficiency of our present forces, their condition, and the skill and ability which distinguish their leaders, inspire the belief that no further enrolment will be necessary, but a wise foresight requires that if a necessity should be suddenly developed during the recess of Congress requiring increased forces for our defence, means should exist for calling such forces into the field, without awaiting the reassembling of the legislative department of the Government.

In the election and appointment of officers for the provisional army, it was to be anticipated that mistakes would be made, and incompetent officers of all grades introduced into the service. In the absence of experience, and with no reliable guide for selection, executive appointments, as well as elections, have been sometimes unfortunate. The good of the service, the interests of our country, require that some means be devised for withdrawing the commissions of officers who are incompetent for the duties required by their position, and I trust that you will find means for relieving the army of such officers by some mode more prompt and less wounding to the sensibility than judgment of court martial.

Within a recent period we have effected the object so long desired, of an arrangement for the exchange of prisoners, which is now being executed by delivery at the points agreed upon, and which will, it is hoped, speedily restore our brave and unfortunate countrymen to their places in the ranks of the army, from which, by the fortune of war, they have for a time been separated. The details of this arrangement will be communicated to you in a special report when further progress has been made in their execution.

Of other particulars concerning the operations of the War Department you will be informed by the Secretary in his report and the accompanying documents.

The report of the Secretary of the Navy embraces a statement of the operations and present condition of this branch of the public service, both afloat and ashore; the construction and equipment of armed vessels at home and abroad, the manufacture of ordnance and ordnance stores, the establishment of workshops and the development of our resources of coal and of iron. Some legislation seems essential for securing crews for vessels. The difficulties now experienced on this point are fully stated in the Secretary's report, and I invite your attention to providing a remedy.

The report of the Postmaster-General discloses the embarrassments which resulted in the postal service from the occupation by the enemy of the Mississippi river and portions of the territory of the different States. The measures taken by the department for relieving these embarrassments, as far as practicable, are detailed in the report. It is a subject of congratulation, that during the ten months which ended on the 31st of March last, the expenses of the department were largely decreased, whilst its revenue was augmented, as compared with a corresponding period ending on the 30th June, 1860, when the postal service for these States was conducted under the authority delegated to the United States. Sufficient time has not yet elapsed to determine whether the measures heretofore devised by Congress will accomplish the end of bringing the expenditures of the department within the limit of its own revenues by the first of March next, as required by the Constitution.

I am happy to inform you that, in spite both of blandishments and threats, used in profusion by the agents of the Government of the United States, the Indian nations within the Confederacy have remained firm in their loyalty and steadfast in the observance of their treaty engagements with this Government. Nor has their fidelity been shaken by the fact that, owing to the vacancies in some of the offices of agents and superintendents, delay has occurred in the payments of the annuities and allowances to which they are entitled. I would advise some provision authorizing payments to be made by other officers, in the absence of those especially charged by law with this duty.

We have never-ceasing cause to be grateful for the favor with which God has protected our infant Confederacy. And it becomes us reverently to return our thanks and humbly to ask of his bounteousness that wisdom which is needful for the performance of the high trusts with which we are charged.

JEFFERSON DAVIS.

*Emancipation Proclamation of President LINCOLN, issued January 1st, 1863.*

Whereas on the 22d day of September, in the year of our Lord one thousand eight hundred and sixty-two, a proclamation was issued by the President of the United States, containing, among other things, the following, to wit:

"That on the first day of January, in the year of our Lord one thousand eight hundred and sixty-three, all persons held as slaves within any State or designated part of a State, the people whereof shall then be in rebellion against the United States, shall be then, thenceforward, and for ever free; and the Executive Government of the United States, including the military and naval authority thereof, will recognize and maintain the freedom of such persons, and will do no act or acts to repress such persons, or any of them, in any efforts they may make for their actual freedom.

"That the Executive will, on the first day of January aforesaid, by proclamation, designate the States and parts of States, if any, in which the people thereof, respectively, shall then be in rebellion against the United States; and the fact that any State, or the people thereof, shall on that day be in good faith represented in the Congress of the United States, by members chosen thereto at elections wherein a majority of

the qualified voters of such State shall have participated, shall, in the absence of strong countervailing testimony, be deemed conclusive evidence that such State, and the people thereof, are not then in rebellion against the United States."

Now, therefore, I, Abraham Lincoln, President of the United States, by virtue of the power in me vested as Commander-in-Chief of the Army and Navy of the United States in time of actual armed rebellion against the authority and Government of the United States, and as a fit and necessary war measure for suppressing said rebellion, do, on this first day of January, in the year of our Lord one thousand eight hundred and sixty-three, and in accordance with my purpose so to do, publicly proclaimed for the full period of one hundred days, from the day first above mentioned, order and designate as the States and parts of States wherein the people thereof respectively are this day in rebellion against the United States, the following, to wit:

Arkansas, Texas, Louisiana (except the parishes of St. Bernard, Plaquemines, Jefferson, St. John, St. Charles, St. James, Ascension, Assumption, Terre Bonne, Lafourche, Ste. Marie, St. Martin, and Orleans, including the city of New Orleans), Mississippi, Alabama, Florida, Georgia, South Carolina, North Carolina, and Virginia (except the forty-eight counties designated as West Virginia, and also the counties of Berkeley, Accomac, Northampton, Elizabeth City, York, Princess Ann, and Norfolk, including the cities of Norfolk and Portsmouth), and which excepted parts are for the present left precisely as if this proclamation were not issued.

And by virtue of the power and for the purpose aforesaid, I do order and declare that all persons held as slaves within said designated States and parts of States are and henceforward shall be free; and that the Executive Government of the United States, including the military and naval authorities thereof, will recognize and maintain the freedom of said persons.

And I hereby enjoin upon the people so declared to be free to abstain from all violence, unless in necessary self-defence; and I recommend to them that, in all cases when allowed, they labor faithfully for reasonable wages.

And I further declare and make known that such persons, of suitable condition, will be received into the armed service of the United States to garrison forts, positions, stations, and other places, and to man vessels of all sorts in said service.

And upon this act, sincerely believed to be an act of justice, warranted by the Constitution upon military necessity, I invoke the considerate judgment of mankind, and the gracious favor of Almighty God.

In testimony whereof I have hereunto set my name, and caused the seal of the United States to be affixed.

Done at the city of Washington this first day of January, in the year of our Lord one thousand [L. S.] eight hundred and sixty-three, and of the independence of the United States the eighty-seventh.

ABRAHAM LINCOLN.

By the President:

WILLIAM H. SEWARD, Secretary of State.

### *Retaliatory Proclamation by JEFFERSON DAVIS, President of the Confederate States.*

WHEREAS a communication was addressed on the 6th day of July last, 1862, by Gen. Robert E. Lee, acting under the instructions of the Secretary of War of the Confederate States of America, to Gen. H. W. Halleck, Commander-in-Chief of the United States army, informing the latter that a report had reached this Government that Wm. B. Mumford, a citizen of the Confederate States, had been executed by the United States authorities at New Orleans, for having pulled down the United States flag in that city before its occupation by the United States forces, and calling for a statement of the facts, with a view of retaliation if such an outrage had really been committed under the sanction of the United States; and whereas (no answer

having been received to said letter) another letter was on the 2d of August last (1862), addressed by Gen. Lee, under my instructions, to Gen. Halleck, renewing the inquiries in relation to the execution of the said Mumford, with the information that in the event of not receiving a reply within fifteen days, it would be assumed that the fact was true, and was sanctioned by the Government of the United States; and whereas an answer, dated on the 7th of August last (1862), was addressed to Gen. Lee by Gen. W. H. Halleck, the said General-in-Chief of the armies of the United States, alleging sufficient causes for failure to make early reply to said letter of the 6th of July, asserting that "No authentic information had been received in relation to the execution of Mumford, but measures will be immediately taken to ascertain the facts of the alleged execution," and promising that Gen. Lee should be duly informed thereof; and whereas, on the 25th of November last (1862), another letter was addressed, under my instructions, by Robert Ould, Confederate agent for the exchange of prisoners, under the cartel between the two Governments, to Lieut.-Col. W. H. Ludlow, agent of the United States under said cartel, informing him that the explanation promised in the said letter of Gen. Halleck, of the 7th of August last, had not yet been received, and that if no answer was sent to the Government within fifteen days from the delivery of this last communication, it would be considered that an answer is declined; and whereas, in a letter dated on the 3d day of the present month of December, the said Lieut.-Col. Ludlow apprized the said Robert Ould that the above-recited communication of the 19th of November had been received and forwarded to the Secretary of War of the United States, and whereas this last delay of fifteen days allowed for answer has elapsed, and no answer has been received; and whereas, in addition to the tacit admission resulting from the above refusal to answer, I have received evidence fully establishing the truth of the fact that the said Wm. B. Mumford, a citizen of the Confederacy, was actually and publicly executed in cold blood by hanging, after the occupation of New Orleans by the forces under Gen. Benjamin F. Butler, when said Mumford was an unresisting and non-combatant captive, and for no offences even alleged to have been committed by him subsequent to the date of the capture of said city; and whereas the silence of the Government of the United States, and its maintaining of said Butler in high office under its authority for many months after his commission of an act that can be viewed in no other light than as a deliberate murder, as well as of numerous other outrages and atrocities hereafter to be mentioned, afford evidence too conclusive that the said Government sanctions the conduct of the said Butler, and is determined that he shall remain unpunished for these crimes;

Now, therefore, I, Jefferson Davis, President of the Confederate States of America, and in their name do pronounce and declare the said Benjamin F. Butler a felon, deserving capital punishment. I do order that he be no longer considered or treated simply as a public enemy of the Confederate States of America, but as an outlaw and common enemy of mankind, and that in the event of his capture, the officer in command of the capturing force do cause him to be immediately executed by hanging, and I do further order that no commissioned officer of the United States taken captive shall be released on parole before exchange until the said Butler shall have met with due punishment for his crimes. And whereas the hostilities waged against this Confederacy by the forces of the United States, under the command of said Benjamin F. Butler, have borne no resemblance to such warfare as is alone permissible by the rules of international law or the usages of civilization, but have been characterized by repeated atrocities and outrages;

The following are examples:

Peaceful and aged citizens, unresisting captives, and non-combatants have been confined at hard labor with chains attached to their limbs, and are so held in dungeons and fortresses; others have been submitted to a

like degrading punishment for selling medicine to the sick soldiers of the Confederacy. The soldiers have been incited and encouraged by general orders to insult and outrage the wives, the mothers, and the sisters of our citizens, and helpless women have been torn from their homes and subjected to solitary confinement, some in fortresses and prisons, especially one, on an island of barren sand, under a tropical sun, have been fed with loathsome rations, and have been exposed to the vilest insults. Prisoners of war who surrendered to the naval forces of the United States on the agreement that they should be released on parole have been seized and kept in close confinement; and repeated pretenses have been sought or invented for plundering the inhabitants of the captured city by fines levied and collected under threat of imprisonment at hard labor with ball and chain. The entire population of New Orleans have been forced to elect between starvation by the confiscation of all their property, and taking an oath against their conscience to bear allegiance to the invader of their country. Egress from the city has been refused to those whose fortitude withstood the test, and even to lone and aged women, and to helpless children, and after being ejected from their houses and robbed of their property, they have been left to starve in the streets or subsist on charity. The slaves have been driven from the plantations in the neighborhood of New Orleans, until their owners consent to share their crops with the Commanding General, his brother Andrew J. Butler, and other officers, and when such consent had been extorted the slaves have been restored to the plantations, and then compelled to work under the bayonets of the guard of United States soldiers. Where that partnership was refused armed expeditions have been sent to the plantations to rob them of everything that was susceptible of removal, and even slaves too aged and infirm for work have, in spite of their entreaties, been forced from the homes provided by their owners and driven to wander helpless on the highway. By a recent order, No. 91, the entire property in that part of Louisiana, west of the Mississippi river, has been sequestrated for confiscation, and officers have been assigned to the duty, with orders to gather up, collect the personal property, and turn over to the proper officers, upon their receipts, such of said property as may be required for the use of the United States army; to collect together all the personal property and bring the same to New Orleans, and cause it to be sold at public auction to the highest bidders. An order, which, if executed, condemns to punishment by starvation, at least a quarter of a million of all ages, sexes, and conditions, and of which the execution, although forbidden to military officers by orders of President Lincoln, is in accordance with the confiscation law of our enemy, which he has enforced through the agency of cruel officials; and finally the African slaves have not only been incited to insurrection by every license and encouragement, but numbers of them have actually been armed for a servile war—a war in its nature far exceeding the horrors and most merciles atrocities of savages. And whereas the officers under the command of the said Butler have been in many instances active and zealous agents in the commission of these crimes, and no instance is known of the refusal of any one of them to participate in the outrages above narrated. And whereas the President of the United States has by public and official declaration signified, not only his approval of the effort to excite servile war within the Confederacy, but his intention to give aid and encouragement thereto if these independent States shall continue to refuse submission to a foreign power after the 1st day of January next, and he has thus made known that all the appeals to the law of nations, the dictates of reason and instincts of humanity would be addressed in vain to our enemy, and that they can be deterred from the commission of these crimes only by the horrors of just retaliation. Now, therefore, I, Jefferson Davis, President of the Confederate States, and acting by their authority, appeal to divine justice in altering my conduct that I am not guided by the passion of

revenge, but reluctantly yield to the solemn duty of redressing by necessary severity the crimes of which their citizens are the victims, and thus issue my proclamation, and by virtue of my authority as Commander-in-Chief of the army of the Confederate States, do order:

1st. That all commissioned officers in the command of the said Benjamin F. Butler be declared not entitled to be considered as soldiers engaged in honorable warfare, but as robbers and criminals deserving death, and that they and each of them be, whenever captured, reserved for execution.

2d. That the private soldiers and non-commissioned officers of the army of said Butler be considered as only the instruments for the commission of crimes perpetrated by his orders, and not as free agents, and that they, therefore, be treated, when captured, as prisoners of war, with kindness and humanity, and be sent home on the usual parole that they will in no manner aid or serve the United States in any capacity during the continuance of this war, unless duly exchanged.

3d. That all negro slaves captured in arms be at once delivered over to the executive authorities of the respective States to which they belong, to be dealt with according to the laws of said States.

4th. That the like orders be executed in all cases with respect to all commissioned officers of the United States, when found serving in company with said slaves in insurrection against the authorities of the different States of this Confederacy.

In testimony whereof, I have signed these presents and cause the seal of the Confederate States of America to be affixed thereto, at the city of Richmond, on the 23d day of December, in the year of our Lord one thousand eight hundred and sixty-two.

(Signed) JEFFERSON DAVIS.

By the President,  
J. H. BENJAMIN, Sec. of State.

*The overtures of France and the replies of Great Britain and Russia on mediation in the affairs of the United States:*

The following is the despatch of the French Minister of Foreign Affairs addressed to the Ambassadors of France at London and St. Petersburg:

PARIS, Oct. 30, 1862.

Europe watches with painful interest the struggle which has been raging more than a year upon the American continent. The hostilities have provoked sacrifices and efforts certainly of a nature to inspire the highest ideas of the perseverance and energy of the two populations. But this spectacle, which does so much honor to their courage, is only given at the price of numberless calamities and a prodigious effusion of blood. To these results of civil war, which from the very first assumed vast proportions, there is still to be added the apprehension of servile war, which would be the culminating point of so many irreparable disasters.

The suffering of a nation toward which we have always professed a sincere friendship would have sufficed to excite the sincere solicitude of the Emperor, even had we ourselves not suffered by the counterblow of these events. Under the influence of intimate relations which extensive intercourse has multiplied between the various regions of the globe, Europe itself has suffered from the consequences of the crisis which has dried up one of the most fruitful sources of public wealth, and which has become, for the great centres of labor, a cause of the most sad trials.

As you are aware, when the conflict commenced, we held it our duty to observe the most strict neutrality in concert with other maritime Powers, and the Washington Cabinet has repeatedly acknowledged the honorable manner with which we adhered to that line of conduct. The sentiments dictated to us have undergone no change, but of a benevolent character. That

neutrality, instead of imposing upon the Powers the attitude which might resemble indifference, ought rather to make them of service to the two parties by helping them out of a position which seems to have no issue. From the commencement of the war an armed force was set on foot by the belligerents, which since then has almost constantly been kept up. After so much bloodshed, they are now, in that respect, nearly in the same position—nothing authorizing the presumption that more decisive military operations will shortly occur, according to the last news received in Europe. The two armies, on the contrary, were in a condition that would not allow either party to hope, within a brief delay, for any decided advantage to turn the balance and accelerate the conclusion of a peace.

All these circumstances, taken together, point to the opportunity of an armistice, to which, moreover, under the present circumstances, no strategical objection can be made. The favorable dispositions toward peace which are beginning to manifest themselves in the North, as well as in the South, might, on the other hand, second steps that might be made to recommend the idea of truce.

The Emperor has, therefore, thought that the occasion has presented itself of offering to the belligerents the support of the good offices of the maritime Powers; and his Majesty has charged me to make the proposition of this Government to her Britannic Majesty, as well as to the Court of Russia. The three Cabinets would exert their influence at Washington, as well as with the Confederates, to obtain an armistice for six months, during which every act of war, direct or indirect, should provisionally cease on sea as well as on land, and it might be, if necessary, ulteriorly prolonged.

The overtures, I need not say, sir, would not imply, on our part, any judgment on the origin or issue of the struggle, nor any pressure upon the negotiations which might, it is to be hoped, ensue in favor of an armistice. Our task would consist solely in smoothing down obstacles, and in interfering only in a measure determined upon by the two parties. We should not, in fact, believe ourselves called upon to decide, but to prepare the solution of difficulties which hitherto have opposed reconciliation between the belligerent parties. Would not, moreover, an agreement between the three Courts respond sufficiently to their intentions? Would it not give to their step the character of evident impartiality? Acting in concert, they would combine the conditions best suited to inspire confidence—the Government of the Emperor, by the constant tradition of French policy toward the United States; England, by the community of race; Russia, by the marks of friendship she has never ceased to show to the Washington Cabinet.

Should the event not justify the hope of the three Powers, and should the ardor of the struggle overrule the wisdom of their councils, this attempt would not be the less honorable for them. They would have fulfilled a duty of humanity, more especially indicated in a war which has excited passions which render all direct attempts at negotiation more difficult. It is the mission which international law assigns neutrals; at the same time it prescribes to them a strict impartiality, and they could never make a nobler use of their influence than by endeavoring to put an end to a struggle which causes so much suffering, and compromises such great interests throughout the whole world.

Finally, even without immediate results, these overtures would not be entirely useless, for they might encourage public opinion to views of conciliation, and thus contribute to hasten the moment when the return of peace might become possible.

I request you, sir, in the name of his Majesty, to submit these considerations to Lord Russell or to Prince Gortchakoff, begging him to state the views of the Government of her Britannic Majesty or the Court of Russia.

DROUYN DE L'HUYS.

In reply to the above despatch the following

despatch was addressed by Earl Russell to Earl Cowley, her Majesty's Ambassador at Paris:

FOREIGN OFFICE, Nov. 12, 1862.

MR LORD: The Comte de Flahault came to the Foreign Office by appointment on Monday, 10th instant, and read to me a despatch from M. Drouyn de L'Huys relating to the civil war in North America.

In this despatch the Minister of Foreign Affairs states that the Emperor has followed with painful interest the struggle which had now been going on for more than a year on the American continent. He does justice to the energy and perseverance which have been displayed by both sides, but he observes that these proofs of their courage have been given at the expense of innumerable calamities and immense bloodshed; to these accompaniments of the civil conflict is to be added the apprehension of servile war, which would be the climax of so many irreparable misfortunes.

If these calamities affected America only, these sufferings of a friendly nation would be enough to excite the anxiety and sympathy of the Emperor; but Europe also has suffered in one of the principal branches of her industry, and her artisans have been subjected to most cruel trials. France and the maritime Powers have, during the struggle, maintained the strictest neutrality, but the sentiments by which they are animated, far from imposing on them anything like indifference, seem, on the contrary, to require that they should assist the two belligerent parties in an endeavor to escape from a position which appears to have no issue. The forces of the two sides have hitherto fought with balanced success, and the latest accounts do not show any prospect of a speedy termination of the war.

These circumstances taken together would seem to favor the adoption of measures which might bring about a truce. The Emperor of the French, therefore, is of the opinion that there is now an opportunity of offering to the belligerents the good offices of the maritime Powers. He, therefore, proposes to her Majesty, as well as to the Emperor of Russia, that the three Courts should endeavor, both at Washington and in communication with the Confederate States, to bring about a suspension of arms for six months, during which time every act of hostility, direct or indirect, should cease, at sea as well as on land. This armistice might, if necessary, be renewed for a further period.

This proposal, Drouyn de L'Huys proceeds to say, would not imply on the part of the three Powers any judgment on the origin of the war, or any pressure on the negotiations for peace, which, it is hoped, would take place during the armistice. The three Powers would only interfere to smooth the obstacles, and only within the limits which the two interested parties would prescribe. The French Government is of the opinion that, even in the event of a failure of immediate success, these overtures might be useful in leading the minds of men now heated by passion to consider the advantages of conciliation and peace.

Such is in substance the proposal of the Government of the Emperor of the French, and I need hardly say that it has attracted the serious attention of her Majesty's Government. Her Majesty is desirous of acting in concurrence with France upon the great questions now agitating the world, and upon none more than on the contingencies connected with the great struggle now going on in North America. Neither her Majesty the Queen, nor the British nation, will ever forget the noble and emphatic manner in which the Emperor of the French vindicated the laws of nations and assisted the cause of peace in the instance of the seizure of the Confederate Commissioners on board the Trent.

Her Majesty's Government recognizes with pleasure the design of arresting the progress of war by friendly measures, the benevolent views and humane intentions of the Emperor. They are also of the opinion that if the steps proposed were to be taken, the concurrence of Russia would be extremely desirable.



Her Majesty's Government have, however, not been informed up to the present time that the Russian Government have agreed to cooperate with England and France on this occasion, although that Government may support the endeavors of England and France to attain the end proposed.

But is the end proposed attainable at the present moment by the course suggested by the Government of France? Such is the question which has been anxiously and carefully examined by her Majesty's Government. After weighing all the information which has been received from America, her Majesty's Government are led to the conclusion that there is no ground at the present moment to hope that the Federal Government would accept the proposal suggested, and a refusal from Washington at the present time would prevent any speedy renewal of the offer.

Her Majesty's Government think, therefore, that it would be better to watch carefully the progress of opinion in America, and if, as there appears reason to hope, it may be found to have undergone, or may undergo hereafter, any change, the three Courts might then avail themselves of such change to offer their friendly counsel with a greater prospect than now exists of its being accepted by the two contending parties.

Her Majesty's Government will communicate to that of France any intelligence they may receive from Washington or Richmond bearing on this important subject.

Your Excellency may read this despatch to M. Drouyn de L'Huys, and give him a copy of it.

RUSSELL.

The following is the reply of the Russian Government to the French proposal of mediation in America :

*Despatch of Prince Gortchakoff to M. D' Oubri, Chargé d' Affaires of Russia at Paris.*

St. PETERSBURG, Oct. 27 (Nov. 5), 1862.

SIR: I herewith enclose you a copy of a despatch from M. Drouyn de L'Huys, which the Duke of Montebello has been charged to communicate to us.

It concerns the affairs of North America, and its object is to invite us to an *entente* with France and England to take advantage of the present lassitude of the parties to propose, in common, a suspension of hostilities.

In reply to this overture I reminded the French Ambassador of the solicitude which our august master has never ceased to feel in the American conflict from its very onset, a solicitude caused by the amicable relations existing between the two countries, and of which the Imperial Cabinet has given public proofs. I have assured him that nothing could better respond to our wishes than to see approach the termination of a struggle which we deplore, and that to this effect our Minister at Washington has instructions to seize every favorable opportunity to recommend moderation and conciliation, so as to appease conflicting passions and lead to a wise settlement of the interests at stake. I admitted that such counsels would certainly have greater weight if presented simultaneously and in the same friendly manner by the Great Powers who take an interest in the issue of this conflict.

But I added that, in our opinion, what ought specially to be avoided, was the appearance of any pressure whatsoever of a nature to wound public opinion in the United States, and to excite susceptibilities very easily aroused at the bare idea of foreign intervention. Now, according to the information we have hitherto received, we are inclined to believe that a combined step between France, England, and Russia, no matter how conciliatory and how cautiously made, if it were taken with an official and collective character, would run the risk of causing precisely the very opposite of the object of pacification, which is the aim of the wishes of the three Courts.

We have, therefore, drawn the conclusion that if the

French Government should persist in deeming a formal and collective step opportune, and that if the English Cabinet shares that opinion, it would be impossible for us, at the distance we are at, to anticipate the manner in which such a measure would be received. But if in that case our Minister should not participate officially, his moral support is not the less acquired beforehand to any attempt at conciliation.

By giving it to his colleagues of France and of England, under the friendly form (*forme officieuse*) which he might deem best suited to avoid the appearance of pressure, M. de Stoeckl will only be continuing the position and language which, by order of our august master, he has never ceased to observe since the commencement of the American quarrel.

It is in this sense that I request you to explain yourself to the French Minister of Foreign Affairs, in reply to the communication he has made to us.

GORTCHAKOFF.

The following letter is from the French Minister of Foreign Affairs, M. Drouyn de L'Huys, to M. Mercier, the representative of France at Washington, relative to the preceding overtures :

PARIS, Nov. 23, 1862.

SIR: The proposition we made to London and to St. Petersburg, the text of which I despatched to you by the last mail, has not met with the immediate acquiescence we had some reason to expect. Although we have received but summary information on that subject, I do not hesitate to look upon the common demand, in which we had reason to suppose Great Britain and Russia would associate themselves, as being impossible to be realized.

Convinced as we were that an understanding between the three Powers in the sense presented by us would answer as much the interests of the American people as our own; that even that understanding was in the present circumstances a duty of humanity, you will easily form an idea of our regret at seeing the initiative we have taken, after mature reflection, remain without results. Being also desirous of informing Mr. Dayton of our project, I confidentially communicated it to him, and even read in his presence the despatch sent to London and St. Petersburg.

I could not be surprised that the Minister of the United States should oppose his objections to the project I communicated to him, and to hear him express personally some doubts as to the reception which would be given by the Cabinet at Washington to the joint offers of the good offices of France, Russia, and Great Britain. But whatever might have been the answer of the Federal Government to our overtures, we have not now to solicit or discuss it since the evident dispositions of the two latter Courts were to observe an absolute neutrality. We will return, like them, to the passive attitude which we had also made our duty to observe—an attitude from which we would never have departed had we remained indifferent to the present evils and the fatal consequences of the endless continuation of a devastating war.

The rumors reëchoed by the press on this occasion having seemed to us calculated to deceive public opinion, or at least to leave it in uncertainty about the true character of our movements, we have deemed it proper to cut short all hazardous conjectures to place before the eyes of the world the plain terms of our proposition, confident of the approbation which the country will accord to our motives. We have thought that by giving open publicity to our intentions we would besides establish, against all contrary suppositions, the friendly and conciliatory spirit attending the offer of our good offices, and the respect which, however pressing, we would have manifested for the independence of the United States. In respect to this, sir, we believe that there will be no misunderstanding concerning the incentive of our conduct and of our sentiments, and we desire the Cabinet of Washington to discern in all that has just passed the proof that it

will find us always disposed to lend it, if it should desire at some future time, the assistance we should have been happy to have seen accepted at the present time in the interest of peace and conciliation.

DROUYN DE L'HUYS.

*Treaty between the United States of America and Her Majesty the Queen of the United Kingdom of Great Britain and Ireland for the suppression of the African slave trade. Ratified, April 25, 1862.*

The United States of America and her Majesty the Queen of the United Kingdom of Great Britain and Ireland, being desirous to render more effectual the means hitherto adopted for the suppression of the slave trade carried on upon the coast of Africa, have deemed it expedient to conclude a treaty for that purpose, and have named as their Plenipotentiaries, that is to say: the President of the United States of America, William H. Seward, Secretary of State; and her Majesty the Queen of the United Kingdom of Great Britain and Ireland, the right honorable Richard Bickerton Pemell, Lord Lyons, a peer of her United Kingdom, a knight grand cross of her most honorable order of the Bath, and her Envoy Extraordinary and Minister Plenipotentiary to the United States of America, who, after having communicated to each other their respective full powers, found in good and due form, have agreed upon and concluded the following articles:

ARTICLE 1. The two high contracting parties mutually consent that those ships of their respective navies which shall be provided with special instructions for that purpose, as hereinafter mentioned, may visit such merchant vessels of the two nations as may, upon reasonable grounds, be suspected of being engaged in the African slave trade, or of having been fitted out for that purpose; or of having, during the voyage on which they are met by the said cruisers, been engaged in the African slave trade, contrary to the provisions of this treaty; and that such cruisers may detain, and send or carry away such vessels, in order that they may be brought to trial in the manner hereinafter agreed upon.

In order to fix the reciprocal right of search in such a manner as shall be adapted to the attainment of the object of this treaty, and at the same time avoid doubts, disputes, and complaints, the said right of search shall be understood in the manner and according to the rules following:

First. It shall never be exercised except by vessels of war, authorized expressly for that object, according to the stipulations of this treaty.

Secondly. The right of search shall in no case be exercised with respect to a vessel of the navy of either of the two Powers, but shall be exercised only as regards merchant vessels; and it shall not be exercised by a vessel of war of either contracting party within the limits of a settlement or port, nor within the territorial waters of the other party.

Thirdly. Whenever a merchant vessel is searched by a ship of war, the commander of the said ship shall, in the act of so doing, exhibit to the commander of the merchant vessel the special instructions by which he is duly authorized to search, and shall deliver to such commander a certificate, signed by himself, stating his rank in the naval service of his country, and the name of the vessel he commands, and also declaring that the only object of the search is to ascertain whether the vessel is employed in the African slave trade, or is fitted up for the said trade. When the search is made by an officer of the cruiser who is not the commander, such officer shall exhibit to the captain of the merchant vessel a copy of the before-mentioned special instructions, signed by the commander of the cruiser; and he shall in like manner deliver a certificate signed by himself, stating his rank in the navy, the name of the commander by whose orders he proceeds to make the search, that of the cruiser in which he sails, and the object of the search, as above described. If it appears

from the search that the papers of the vessel are in regular order, and that it is employed on lawful objects, the officer shall enter in the log-book of the vessel that the search has been made in pursuance of the aforesaid special instructions; and the vessel shall be left at liberty to pursue its voyage. The rank of the officer who makes the search must not be less than that of lieutenant in the navy, unless the command, either by reason of death or other cause, is at the time held by an officer of inferior rank.

Fourthly. The reciprocal right of search and detention shall be exercised only within the distance of two hundred miles from the coast of Africa, and to the southward of the thirty-second parallel of north latitude, and within thirty leagues from the coast of the island of Cuba.

ART. 2. In order to regulate the mode of carrying the provisions of the preceding article into execution, it is agreed—

First. That all the ships of the navies of the two nations which shall be hereafter employed to prevent the African slave trade, shall be furnished by their respective governments with a copy of the present treaty, of the instructions for cruisers annexed thereto (marked A), and of the regulations for the mixed courts of justice annexed thereto, marked B, which annexes respectively shall be considered as integral parts of the present treaty.

Secondly. That each of the high contracting parties shall, from time to time, communicate to the other the names of the several ships furnished with such instructions, the force of each, and the names of their several commanders. The said commanders shall hold the rank of captain in the navy, or at least that of lieutenant; it being nevertheless understood that the instructions originally issued to an officer holding the rank of lieutenant of the navy, or other superior rank, shall, in case of his death or temporary absence, be sufficient to authorize the officer on whom the command of the vessel has devolved, to make the search, although such officer may not hold the aforesaid rank in the service.

Thirdly. That, if at any time, the commander of a cruiser, of either of the two nations, shall suspect that any merchant vessel under the escort or convoy of any ship or ships-of-war of the other nation carries negroes on board, or has been engaged in the African slave trade, or is fitted out for the purpose thereof, the commander of the cruiser shall communicate his suspicions to the commander of the convoy, who, accompanied by the commander of the cruiser, shall proceed to the search of the suspected vessel; and in case the suspicions appear well founded, according to the tenor of this treaty, then the said vessel shall be conducted or sent to one of the places where the mixed courts of justice are stationed, in order that it may there be adjudicated upon.

Fourthly. It is further mutually agreed that the commanders of the ships of the two navies, respectively, who shall be employed on this service, shall adhere strictly to the exact tenor of the aforesaid instructions.

ART. 3. As the two preceding articles are entirely reciprocal, the two high contracting parties engage, mutually, to make good any losses which their respective subjects or citizens may incur by an arbitrary and illegal detention of their vessels; it being understood that this indemnity shall be borne by the Government whose cruiser shall have been guilty of such arbitrary and illegal detention; and that the search and detention of vessels specified in the first article of this treaty shall be effected only by ships which may form part of the two navies, respectively, and by such of those ships only as are provided with the special instructions annexed to the present treaty, in pursuance of the provisions thereof. The indemnification for the damages of which this article treats shall be paid within the term of one year, reckoning from the day in which the mixed court of justice pronounces its sentence.

ART. 4. In order to bring to adjudication, with as little delay and inconvenience as possible, the vessels

which may be detained according to the tenor of the first article of this treaty, there shall be established, as soon as may be practicable, three mixed courts of justice, formed of an equal number of individuals of the two nations, named for this purpose by their respective Governments. These courts shall reside, one at Sierra Leone, one at the Cape of Good Hope; and one at New York.

But each of the two high contracting parties reserves to itself the right of changing, at its pleasure, the place of residence of the court or courts held within its own territories.

These courts shall judge the causes submitted to them according to the provisions of the present treaty, and according to the regulations and instructions which are annexed to the present treaty, and which are considered an integral part thereof, and there shall be no appeal from their decision.

Art. 5. In case the commanding officer of any of the ships of the navies of either country, duly commissioned according to the provisions of the first article of this treaty, shall deviate in any respect from the stipulations of the said treaty, or from the instructions annexed to it, the Government which shall conceive itself to be wronged thereby shall be entitled to demand reparation; and in such case the Government to which such commanding officer may belong binds itself to cause inquiry to be made into the subject of the complaint, and to inflict upon the said officer a punishment proportioned to any wilful transgression which he may be proved to have committed.

Art. 6. It is hereby further mutually agreed that every American or British merchant vessel which shall be searched by virtue of the present treaty may lawfully be detained, and sent or brought before the mixed courts of justice established in pursuance of the provisions thereof, if, in her equipment, there shall be found any of the things hereinafter mentioned, namely:

First. Hatchets with open gratings, instead of the close hatchets, which are usual in a merchant vessel.

Second. Divisions or bulk heads in the hold or on deck in greater number than are necessary for vessels engaged in lawful trade.

Third. Spare plank fitted for laying down as a second or slave deck.

Fourth. Shackles, bolts, or handcuffs.

Fifth. A larger quantity of water in casks or in tanks than is requisite for the consumption of the crew of the vessel as a merchant vessel.

Sixth. An extraordinary number of water casks or of other vessels for holding liquid, unless the master shall produce a certificate from the custom-house at the place from which he cleared outward, stating that a sufficient security had been given by the owners of such vessel that such extra quantity of casks or of other vessels should be used only to hold palm oil, or for other purposes of lawful commerce.

Seventh. A greater number of mess tubs or kids than requisite for the use of the crew of the vessel as a merchant vessel.

Eighth. A boiler, or other cooking apparatus, of an unusual size, and larger, or capable of being made larger, than requisite for the use of the crew of the vessel as a merchant vessel; or more than one boiler, or other cooking apparatus, of the ordinary size.

Ninth. An extraordinary quantity of rice, of the flour of Brazil, of manioc or cassada, commonly called farinha, of maize, or of Indian corn, or of any other article of food whatever, beyond the probable wants of the crew; unless such rice, flour, farinha, maize, Indian corn, or other article of food, be entered on the manifest as part of the cargo for trade.

Tenth. A quantity of mats or matting greater than is necessary for the use of the crew of the vessel as a merchant vessel; unless such mats or matting be entered on the manifest as part of the cargo for trade.

If it be proved that any one or more of the articles above specified is or are on board, or have been on board during the voyage in which the vessel was captured, that fact shall be considered as *prima facie* evi-

dence that the vessel was employed in the African slave trade, and she shall in consequence be condemned and declared lawful prize, unless the master or owners shall furnish clear and incontrovertible evidence, proving to the satisfaction of the mixed court of justice that at the time of her detention or capture the vessel was employed in a lawful undertaking, and that such of the different articles above specified as were found on board at the time of detention, or as may have been embarked during the voyage on which she was engaged when captured, were indispensable for the lawful object of her voyage.

Art. 7. If any one of the articles specified in the preceding article as grounds for condemnation should be found on board a merchant vessel, or should be proved to have been on board of her during the voyage on which she was captured, no compensation for losses, damages, or expenses consequent upon the detention of such vessel, shall, in any case, be granted either to the master, the owner, or any other person interested in the equipment or in the lading, even though she should not be condemned by the mixed court of justice.

Art. 8. It is agreed between the two high contracting parties that in all cases in which a vessel shall be detained under this treaty by their respective cruisers as having been engaged in the African slave trade, or as having been fitted out for the purposes thereof, and shall consequently be adjudged and condemned by one of the mixed courts of justice to be established as aforesaid, the said vessel shall immediately after its condemnation be broken up entirely, and shall be sold in separate parts, after having been so broken up, unless either of the two Governments should wish to purchase her for the use of its navy, at a price to be fixed by a competent person chosen for that purpose by the mixed courts of justice, in which case the Government whose cruiser shall have detained the condemned vessel shall have the first option to purchase.

Art. 9. The captain, master, pilot, and crew of any vessel condemned by the mixed courts of justice shall be punished according to the laws of the country to which such vessel belongs, as shall also the owner or owners and the persons interested in her equipment or cargo, unless they prove that they had no participation in the enterprise.

For this purpose the two high contracting parties agree that, in so far as it may not be attended with grievous expenses and inconvenience, the master and crew of any vessel which may be condemned by a sentence of one of the mixed courts of justice, as well as any other persons found on board the vessel, shall be sent and delivered up to the jurisdiction of the nation under whose flag the condemned vessel was sailing at the time of capture; and that the witnesses and proofs necessary to establish the guilt of such master, crew, or other persons, shall also be sent with them.

The same course shall be pursued with regard to subjects or citizens of either contracting party who may be found by a cruiser of the other on board a vessel of any third Power, or on board a vessel sailing without flag or papers, which may be condemned by any competent court for having engaged in the African slave trade.

Art. 10. The negroes who are found on board of a vessel condemned by the mixed courts of justice, in conformity with the stipulations of this treaty, shall be placed at the disposal of the Government whose cruiser has made the capture; they shall be immediately set at liberty, and shall remain free, the Government to whom they have been delivered guaranteeing their liberty.

Art. 11. The acts or instruments annexed to this treaty, and which it is mutually agreed shall form an integral part thereof, are as follows:

(A.) Instructions for the ships of the navies of both nations, destined to prevent the African slave trade.

(B.) Regulations for the mixed courts of justice.

Art. 12. The present treaty shall be ratified, and the ratifications thereof shall be exchanged at London in six months from this date, or sooner if possible. It

shall continue and remain in full force for the term of ten years from the day of exchange of the ratifications, and further, until the end of one year after either of the contracting parties shall have given notice to the other of its intention to terminate the same, each of the contracting parties reserving to itself the right of giving such notice to the other at the end of said term of ten years. And it is hereby agreed between them that, on the expiration of one year after such notice shall have been received by either from the other party, this treaty shall altogether cease and determine.

In witness whereof the respective plenipotentiaries have signed the present treaty, and have thereunto affixed the seal of their arms.

Done at Washington the seventh day of April, in the year of our Lord one thousand eight hundred and sixty-two.

WILLIAM H. SEWARD. [L. S.]  
LYONS. [L. S.]

An additional article to the preceding treaty was subsequently agreed upon, which extends the right of visit and detention, by providing that it may be exercised within thirty leagues of the Island of Madagascar, within thirty leagues of the Island of Puerto Rico, and within the same distance of the Island of San Domingo. Benjamin Pringle was appointed judge at Cape Town, and — Avery, arbitrator, under this treaty, by the President; also Thomas V. Dyer and M. Hibbard, judge and arbitrator respectively, at Sierra Leone. The respective ratifications of this article were exchanged at London on April 1st, 1863, and made public by the President on the 22d of April.

## R

**REFORMED CHURCHES.** This is the collective name of those churches in Switzerland, Germany, France, Belgium, and Holland which followed the Reformation of Calvin and of Zuingli, and of their offshoots in the United States of America. Of the latter there are two, the Dutch Reformed and the German Reformed Church.

In the Dutch Reformed Church there were, in 1862, 81 classes, answering to the Presbyteries in Presbyterian churches, including the Missionary Classis of Arcot in India. To these was soon to be added a classis in China, where, as in India, the missions are prosperous and where native pastors will soon be placed over the mission churches. With a view to meet this exigency, the constitution, in its application to such churches, is to be so modified as to dispense with the attendance of a deputation from another classis, when a candidate for license, or for a pastorate, is examined. These classes—the 81 in the whole church—have 429 churches and 419 ministers, an average of nearly 14 ministers and 14 churches in each, and each classis is entitled to a representation of 8 ministers and 8 elders in the Particular Synods (answering to the synods in the Presbyterian Church), and to the same number in the General Synod. Hence a full general synod would have nearly two hundred members. The churches have an average of about 80 families, and 120 communicants each, and raise about 8 dollars for benevolent objects, and more than 7 dollars for congregational purposes, yearly, to each communicant. The contributions for domestic missions the past year exceeded by about 2,600 dollars those of the previous year, while those for foreign missions showed a slight falling off.

The annual union of the General Synod of the Dutch Reformed Church, in 1862, commenced in Syracuse, New York, on June 4, and was attended by about 150 delegates. Rev. John Garretson, D.D., was elected president. On motion of Rev. Romeyn Berry a series of resolutions on the state of the country were adopted by a large majority, pledging "an ear-

nest and unqualified support to the Government in its efforts to suppress this disastrous and most wicked rebellion" and declaring that their prayers shall continually be that "God in infinite wisdom will guide us in a way by which in the best manner every yoke may in his own time be broken and the oppressed go free." The General Synod also resolved to celebrate in an appropriate manner the adoption of the Belgic Confession of Faith, one of the doctrinal standards of the Reformed churches, in 1563, and appointed to that end the second Sabbath in September, requesting all the churches of the denomination to hold a special service at their usual hour of morning worship.

Since the great split in the Presbyterian church in 1837, the Dutch Reformed Church has held correspondence only with the Old School body, but at its session of 1862, the General Synod adopted a resolution proposing to open correspondence with the New School Assembly. The New School Presbyterian papers complained, however, that inasmuch as the General Synod said in substance that the proposal was not made on the ground that the New School Church was *sound in the faith*, the New School Assembly could not with any regard to its own dignity or self-respect entertain it.

The German Reformed Church of the United States reported, in 1862, the following statistics: synods, 2, classes, 25, ministers, 421, congregations, 1,122, members, 100,691, baptisms, 11,894. Compared with the report of the previous year, this shows the following increase: ministers 7, congregations 69, members 3,284, baptisms 81. Of the members about 70,000 belong to the Eastern Synod, and about 30,000 to the Western. The two synods are represented in general synod, which meets once in three years, and is the highest judicatory of the church. The German Reformed Church has only a feeble representation in the slave States, only three of its classes—Maryland, Virginia, and North Carolina—being located there. The connection of the North Carolina classis with

the church has been for several years very loose, yet, as far as is known, no effort has yet been made to organize an independent church.

For the last twelve years, the German Reformed Church has been considerably agitated by the liturgical question, some of the leading men of the Eastern Synod—as Dr. Nevin, Dr. Schaff, Dr. Gerhard—favoring a more strictly ritualistic or altar worship than has before been in use in the church; while the Western Synod and a minority of the Eastern Synod have taken ground against the liturgical change. Six years ago, the draft of a liturgy was presented to the Eastern Synod by a liturgical committee, and ordered to be printed for provisional use. In 1862, the synod had another long discussion on the Provisional Liturgy, a version of which has been demanded by most of the classes. It was finally resolved to allow the liturgy to remain in the church provisional use for five years longer.

In Switzerland the great majority of the Protestant population, which, according to last census of 1860, numbered 1,476,982 souls, belongs to the Reformed State Church, which in every canton has an independent organization. For several years, a kind of union between the cantonal churches has been established by means of an Annual Helvetic Conference, an assembly of delegates from the the church governments of the several cantons. Its resolutions are, however, merely advisory. Conformity with the old Confessions of Faith is nowhere insisted upon in the Reformed State churches, and there prevails therefore the greatest possible divergence of theological opinions. Besides the State churches there are a number of independent Reformed churches, which have, however, generally only a small membership.

In Germany, a considerable portion of the Reformed churches has been absorbed by the United Evangelical Church, which was formed out of a union of the Reformed and the Lutheran churches. There are, however, still Reformed churches in a number of states, especially in Hanover (97,018 souls); Bavaria, Hesse-Cassel, Hesse-Darmstadt (29,200 souls), Bremen, and several others. Several years ago, annual conferences of the German Reformed churches began to be held, but the participation in them has not yet become general, and there is as yet no kind of official communication between them. Of the theological faculties of the German universities none is exclusively Reformed.

In Austria, the Reformed Church, which is officially called the Evangelical Church of Helvetic Confession, is divided into three independent bodies, whose condition was, in 1862, as follows: 1. The Evangelical Church of Helvetic Confession in Hungary had 4 superintendentships (synods), called the superintendentships on the Danube, beyond the Danube, this side of the Theiss, and beyond the Theiss; 88 "Seniorats" (presbyteries), 1,427 congregations, and a population of 1,511,842 souls. 2.

3. The Evangelical Church of H. C. in Transylvania, had 1 superintendentship, 18 districts, 559 congregations, and a population of about 800,000 souls. 3. The Reformed churches in the German and Slavic countries of Austria, are comprised with the Lutherans into one organization, in which the Lutherans form 5, and the Reformed 3 superintendentships (Vienna, Prague, and Ingrowitz in Moravia). The latter have the following statistics: 1. Vienna, 3 congregations, 6,810 souls; 2. Prague, 3 "Seniorats," 38 congregations, 56,882 souls; 3. Ingrowitz, 2 "Seniorats," 19 congregations, 84,797 souls.

The Reformed State Church of France had, in 1862, 105 consistories, 477 parishes with 688 stations, 889 churches and oratories, 1,293 schools, 567 official pastors, 82 assistant pastors and chaplains. The mixed consistory of Algiers (comprising under its jurisdiction both the Lutheran and Reformed churches of Algeria) had 18 parishes, 30 stations, 42 places of worship, 15 pastors.

Holland has an established and a free Reformed church. In the former liberal (rationalistic) principles prevail, while the latter adheres strictly to the old standards of the church. To the former belongs a population of about 1,900,000, to the latter about 55,000 souls.

Belgium has likewise a Reformed church which is recognized and supported by the state, and free Reformed churches. The former had, in 1859, 16 preachers; the latter, likewise, 16 preachers and 4 evangelists. Both together are supposed to have a population of about 25,000 souls.

Russia had in 1860 1,045 German Reformed in the Baltic provinces, 3,772 in St. Petersburg, 11,911 in Lithuania and the adjoining Polish provinces, 36,000 in the interior of the empire. Many of them were, however, in connection with the Lutheran Church.

In Asia, the Dutch Reformed Church of the United States has a number of missionary congregations in India and China, which in the former country have been organized into a regular classis. The same church has also commenced a mission in Japan. The State Church of Holland has a number of flourishing missions in the large Dutch possessions in the Archipelago.

In Africa, the Dutch Reformed Church has still the character of State Church in the Cape colony. The Dutch language has been hitherto used in all the churches, but the synod of the church, held in 1862, made provision for the use of the English language, where there was a sufficient demand for it.

RHODE ISLAND, one of the New England States, and the smallest of the Union excepting Delaware, had in 1860 a population of 174,620, which was an increase of 27,075 during the ten years ending June, 1860. The industrial and commercial statistics of this enterprising little State will be found under UNITED STATES.

The governor of the State in 1862 was Wm. Sprague. The election takes place on the first

Wednesday of April. The citizens of the State were divided into three parties, the republican, the democratic, and Union. The democratic and Union parties united at the election in 1861, and elected Governor Sprague. The Union party was comparatively small in numbers. On the 20th of February, 1862, the democratic electors of the State assembled by their representatives in convention at Providence, and nominated William Sprague for reelection as governor; Samuel G. Arnold for lieutenant governor; John R. Bartlett, secretary of State; Walter S. Burgess, attorney general, and Samuel A. Parker, treasurer. The views of the convention on national affairs were expressed by the following resolutions:

*Resolved*, That the Democracy of Rhode Island stand to-day upon their ancient platform; that they are for the country, and nothing less than the country—for the Union and the Constitution, without conditions or higher law reservations—for peace with all men and all nations, when it can be honorably secured or preserved, and for war when peace is no longer consistent with national dignity or the preservation of the people's just rights—for a strict construction of the Constitution of the country, and a sacred regard, at all times and under all circumstances, by ruler as well as people, by servant as well as citizen, for all its guaranties and provisions—for the preservation of the freedom of speech, and the liberty of the press,—for an honest and economical administration of the Government, the faithful guardianship of the public credit, and the prompt punishment of treasury plunderers; and against all encroachments upon State or individual rights—against the irresponsible exercise, by public servants, of powers not delegated in the Constitution—against oppression of every description—against sectionalism in all its aspects—against underground railroads and John Brown raids, and, finally and especially, against all attempts by the Federal Government to subjugate States or divest their governments or people of any of the powers or privileges which they have heretofore exercised or enjoyed.

*Resolved*, That the so-called "Right of Secession," claimed by many politicians and citizens of States now in arms against our Federal Government, is inconsistent with all government, and a denial of the fundamental principles of all democratic republics. It is just as false to-day as it was only a few years or months ago, when it was claimed by Northern abolitionists and at least one Northern Legislature, and should be condemned and opposed by all good men, at all times, as tending to the abrogation of law and the inauguration of civil war. And, denying the right of secession, we declare that the present rebellion against Federal authority, and the attempt to overthrow, by a resort to force, the best government which the sun ever shone upon, is both unreasonable and criminal—an indefensible violation of all the pledges which citizenship implies, and such an outrage against humanity and civilization as even the aggressions and menaces of Northern abolitionists, during thirty years of vengeful warfare upon Southern institutions, cannot justify or palliate.

*Resolved*, That while this civil war continues, it is our duty and the duty of all loyal citizens to render to the Government a cheerful and earnest support; to stand by it in the enforcement of all constitutional measures tending to the suppression of armed rebellion; to give its officers, so far as they are true to the trusts reposed in them, the aid and comfort which may be derived from our moral influence and physical resources. And that we extend to those citizens of our own and other States who have responded to the call of the Government for that protection which arms alone can give, our hearty commendation and warmest sympathies. We congratulate them upon the recent brilliant victories which their valor has achieved,

and bespeak for them, when their work shall have been accomplished and their purpose consummated in the restoration of the Union, the warm gratitude of all true patriots.

*Resolved*, That the effort now being made to divert this war from its original purpose, as proclaimed by the President and Congress of the United States seven months ago—the maintenance of the Federal Constitution and the preservation of the Union's integrity—and to turn it into a war for the emancipation of slaves and the subjugation of the Southern States, or their return to a territorial condition, is an effort against the Union, against the Constitution, against justice, and against humanity, and should be promptly frowned upon by all the friends of democratic institutions. It is unworthy of loyal citizens, and can find support only with sectional fanatics, who have no love for the Union or desire for its restoration, and whose highest patriotism is an unnatural and unrighteous hatred of the citizens of sister States. And whereas we perceive gratifying indications that President Lincoln is resisting and will continue to resist this treasonable effort, it is further resolved, that in such patriotic resistance he is entitled to and does and shall continue to receive our cordial sympathy and unflinching support.

*Resolved*, That to bring the present war to a final and happy conclusion, and secure a union of hearts as well as a union of hands, it is absolutely necessary to reassure the misguided people of the South that we mean no warfare upon their rights, and are actuated by no spirit of revenge; to disavow, in the language of Gov. Sprague, "any other wish than that of bringing together these now belligerent States, without the loss to any one of them of a single right or privilege which it has heretofore enjoyed;" to show, by our acts as well as by our professions, that our whole purpose is to preserve our Government just as it came to us from the hands of our fathers—to regard all the guaranties of the Constitution, whether to States or to people of the States—and to become once more a powerful and prosperous nation, and a harmonious and happy people. And that, to this end, it is the duty of the Democratic party, not only to preserve its distinctive organization, but to demonstrate by honorable and patriotic measures, both its determination and its power to withstand and render harmless the assaults of Northern sectionalists upon constitutional liberty.

*Resolved*, That the effort now being made to secure to adopted citizens in this State their just political rights, meets with our hearty sympathy and is entitled to and shall receive our cordial support; that the purpose of this effort is especially commended to us at this time by the promptness and unanimity with which this class of our citizens are rallying to the support of our institutions; and that we urge upon the present General Assembly of our State to take such measures as are necessary to bring their claims to an equality of political privileges directly before the people.

The course pursued by the governor and other State officers during the previous year had been so satisfactory to the citizens, that the other parties made no nominations for these offices, although their party organization was preserved.

The votes of the electors which were given to Sprague were 11,195, scattering 62.

For members of Congress the vote was as follows:

	Democratic Union.	Republican.
1st Dist. ....	6,998	6,656
2d " .....	4,545	4,004

The members of the Legislature were elected as follows:

	Senate.	House.
Dem. Union.....	21	50
Republican .....	11	23

The Legislature, at its subsequent session, elected Governor Sprague a senator in the Federal Congress.

The debt of the State has been contracted within the last two years to meet the expenses of organizing, equipping, and paying the bounty to its troops. Bonds to the amount of \$1,800,000 at 6 per cent. were authorized to be issued, of which \$1,200,000 were sold at a premium of 11 per cent.

The banking capital of the State amounts to \$20,862,979—divided among 88 banks.

The length of the railroads of the State is 283 miles, costing \$11,670,528.

There is one college in the State, and a Friends' boarding school of a high grade, and many flourishing academies. The public school fund amounts to \$248,000, of which the income is \$14,442 per annum. The average attendance on the schools exceeds 21,691.

Under the calls for troops in 1862, the State filled her quota without a resort to a draft, making all the troops raised by her for the war amount to thirteen regiments consisting of 14,326 officers and men. About 1,500 men were also furnished by the State to the United States navy. Of the troops sent to the war, one regiment was light artillery and one cavalry.

The militia of the State is composed of 2,339 active militia and 17,944 enrolled militia. Of the active militia, 43 belong to the general staff, 77 to the cavalry, 423 to the artillery, 1,574 to the infantry, and 222 to the riflemen.

An unsuccessful attempt was made by Gov. Sprague to enlist a regiment of free colored persons, for which he issued the following order:

STATE OF RHODE ISLAND AND PROVIDENCE PLANTATIONS, ADJ'T-GENERAL'S OFFICE,  
PROVIDENCE, Aug. 4, 1862.

*General Orders No. 26.*—The Sixth Regiment, authorized by the Secretary of War, under date Oct. 23, 1861, and orders issued therefor from this Department, No. 108, Dec. 23, 1861, will consist entirely of colored citizens. Enlistment will commence immediately. Camp will be established under direction of Gen. Robins, who is directed to organize the regiment.

The quartermaster-general will furnish rations and equipments on requisition.

Our colored fellow citizens are reminded that the regiment from this State in the Revolution, consisting entirely of colored persons, was pronounced by Washington equal, if not superior, to any in the service. They constitute a part of the quota from this State, and it is expected they will respond with zeal and spirit to this call.

The commander-in-chief will lead them into the field, and will share with them, in common with the patriotic soldiers of the army of the republic, their trials and dangers, and will participate in the glories of their successes.

By order of the Commander-in-Chief.

EDWARD C. MAURAN, Adjutant-General.

The deposits in the savings institutions of the State, at the beginning of 1862, amounted to \$9,282,879.

RICHARDSON, ISRAEL B., a major-general of volunteers in the United States service, born at Burlington, Vt., in 1819, died at Sharpsburg,

Md., Nov. 3, 1862. He was a descendant of the Revolutionary hero, Gen. Israel Putnam, graduated at West Point in 1841, was appointed 2d lieutenant in the 8d infantry, and 1st lieutenant Sept. 21, 1846. He distinguished himself in nearly every important battle during the Mexican war; was brevetted captain for gallant and meritorious conduct at Contreras and Churubusco, and major for gallantry at Chapultepec—and so distinguished himself for bravery that he was known in the army by the sobriquet of "Fighting Dick." In March, 1851, he was promoted to a captaincy. In 1855, he left the army and retired to private life in Michigan. Upon the commencement of the present war he promptly offered himself again to the Government, organized a regiment, the 2d Michigan volunteers, of which he was made colonel, and soon after was placed in command of a brigade with which he covered the retreat of the army at Bull Run. His commission as brigadier-general dated back to May 12, 1861. At the battle of the Chickahominy he commanded a division of Gen. Sumner's corps and won much honor upon that occasion. He received his commission of major-general July 4, 1862, distinguished himself at the battles of South Mountain and Antietam, in the latter of which he received the wound causing his death.

ROMAN CATHOLIC CHURCH. At the end of the year 1862 the Roman Catholic church counted 902 dioceses with a population of about 182,000,000 souls. They were distributed as follows: America had 148 dioceses, and a Roman Catholic population of about 38,759,000 souls; Europe 603 dioceses, with about 138,103,000; Asia (inclusive of the Archipelago) 102 dioceses, with about 4,167,000; Africa 88 dioceses, with about 1,113,000; Australasia and Polynesia 17 dioceses, with about 280,000 souls.

In America, Central (2,227,000) and South America (21,278,000), Mexico (7,660,000), the French (801,000) and Spanish (2,032,000) possessions have an almost entirely Roman Catholic population. British North America has 19 dioceses, with about 2,590,000 Catholics. The United States has 46 dioceses and 4 Apostolic vicariates, divided into 7 provinces, Baltimore, New York, New Orleans, Cincinnati, St. Louis, Oregon City, and San Francisco, and a Roman Catholic population estimated at from three to four millions.

The statistics of the Roman Catholic population in the countries of Europe was as follows: Italy, 263 dioceses, 24,000,000 Roman Catholics; France, 81 dioceses, 35,734,000 Catholics; Austria (exclusive of Venetia), 58 dioceses, 25,000,000 Catholics; Spain, 58 dioceses, 16,550,000 Catholics; Prussia and the other German states, 24 dioceses, 12,450,000 Catholics; Great Britain, 45 dioceses, 6,000,000 Catholics; Russia, 16 dioceses, 7,020,000 Catholics; Belgium, 6 dioceses, 4,600,000 Catholics; Portugal, 17 dioceses, 3,900,000 Catholics; Turkey, 15

dioceses, 640,000 Catholics; Holland, 6 dioceses, 1,250,000 Catholics; Switzerland, 5 dioceses, 1,023,000 Catholics; Greece, 5 bishoprics, 15,000 Catholics; Scandinavia, 3 dioceses, 6,000 Catholics.

The only country in Asia, in which the Roman Catholic church prevails, is the Philippine Isles. There is, however, a considerable Roman Catholic population also in India (1,033,000), Farther India (520,000), China (837,000), and Turkey (260,000). In Farther India, in consequence of the treaty of peace concluded between France and Cochin China, six provinces of the latter country have been annexed to France, and are likely to become ere long Catholic territory.

In Africa the Catholic church has a stronghold in the Portuguese, Spanish, and French possessions, in some of which the entire population is connected with the church. France is constantly extending her possessions in Northern Africa, where now a territory of 7,107 geographical square miles, and a population of 2,999,124 souls are under her rule, and in Senegambia, where she owns a country of about 5,000 geographical square miles and 252,000 inhabitants.

During the years 1861 and 1862, seventeen new dioceses have been established. Four bishoprics have been organized in America, viz., Marysville and Quincy in the United States, Chatham in New Brunswick, and Puno in Peru; besides two apostolical vicariates, that of the Rocky Mountains in the United States, and Sandwich in British America. In Europe, a new diocese has been organized in Bulgaria (for the United Bulgarians), and the apostolical vicariate, Stockholm, has been made a bishopric. In Asia, episcopal sees have been established at Madiat (for the United Syrians), at Sebaste (for the United Armenians), and at Su-tchuen in China. In Africa, an apostolical prefecture has been established in Senegambia and Zanguebar, and apostolical vicarships in Madagascar and for central Africa. Congo has been separated from Angola, and made a separate bishopric, and a mission has also been commenced in Dahomey.

The present number of secular priests is estimated at about 820,000, of whom about 2,800 belong to the United States, 115,000 to Italy, 50,000 to France, 31,800 to Spain, 30,000 to Germany, 4,000 to the British Isles. There were in 1862 about 8,000 male convents with 120,000 monks, the most numerous orders being the Franciscans (50,000), the brothers of the Christian schools (16,000), the Jesuits (8,000), Benedictines (5,000), Dominicans (4,000), Augustines (4,000). The female religious orders had about 190,000 members, of whom about 10,000 belonged to North America, 10,000 to South America, 100,000 to France, 80,000 to Italy, 10,000 to Belgium.

The most important event in the history of the Roman Catholic church during the year 1862, was the great council in Rome, to which all

the Roman Catholic bishops of the world had been specially invited by the Pope. The primary object of the council, according to the circular by which the presence of the bishops was solicited, was the canonization of some Japanese martyrs; but even before the council met, it was generally known that the most important subject of deliberation would be a joint and solemn declaration of the assembled episcopate on the temporal power of the Pope. The council was held on Sunday, June 8th, and Monday, June 9th. On Sunday the Japanese martyrs were canonized in the most solemn manner in the Basilica of St. Peter. The ceremony lasted 6 hours, and was attended by an immense concourse of bishops, priests, and people. On Monday, June 9th, the Pope held a consistory at which all the foreign bishops were present. He pronounced an allocution, in which he deplored the errors spread by the revolutionary spirit against the authority of the Catholic church, as well as against divine and human laws. In reply to this allocution, the bishops signed an address to the Pope, in which they declare that the temporal power is necessary for the independence of the papal power. They approve all that the Pope has done in defence of his power, and exhort him to continue firm in his resistance. The address is signed by 21 cardinals and two hundred and forty-four bishops. An authentic history of the proceedings of the council has not yet been published, but a series of articles in a daily newspaper of Paris, "*La Patrie*," which claimed to give the minutest accounts of all the proceedings, called out letters from the bishop of Montauban and Cardinal Wiseman, which established at least some important points of the history of the council. Prominent among the great number of bishops were Cardinal Wiseman and Bishop Dupanloup of Orleans. The bishops did not appoint themselves a committee for preparing an address to the Pope, because as the bishop of Montauban says, "no one had the right of taking the initiative in such a grave question" and the Pope was therefore asked to designate the members of the committee. The committee consisted of eighteen members, and the great Roman Catholic nations, Spain, France, Italy, Austria, were each represented by one archbishop and one bishop. Cardinal Wiseman was selected as president, in order to avoid a jealousy of these four Catholic nations against each other. One of the most active and prominent members of the committee was Bishop Dupanloup of Orleans. The address, before its adoption, underwent several changes. A vote of thanks to the French Government for its support of the temporal power was proposed, but rejected at the demand of the non-French bishops. Whether, as the "*La Patrie*" had asserted, a passage in favor of liberalism was proposed, the bishop of Montauban says he does not know, but considers it probable, "as the liberal principles were represented at Rome by a certain number of foreign



pilgrims." If it really was proposed, the bishop says, it had to be rejected, because the church cannot express a preference for any form of society. The bishops had no opportunity to examine the address before signing it, but as the bishop of Montauban says, they felt no hesitation, because they knew what its general character would be, and that it had received the approval of the Pope. Nearly every country of the world was represented at the council, only the governments of Italy and Portugal had forbidden their bishops to take part in it. All, or nearly all of the bishops of these two countries, as well as such bishops of other countries as had been absent, signed an address to the Pope, expressing their concurrence with this declaration of the council. It may therefore be said, that the episcopate of the Roman Catholic church, with almost perfect unanimity, has declared in favor of maintaining the temporal power.

The Italian parliament replied immediately to the declaration of the episcopate, by pledging unwavering fidelity to the principle of Italian unity, involving, as it does, the abolition of the temporal power, for which also a number of the lower clergy declared themselves. One of the leading men of this party among the clergy, Father Passaglia, drew up an address to the Pope, requesting him to abandon voluntarily the temporal power, and he claimed to have obtained for this address the signatures of about ten thousand priests, whose names he published in his journal, *Il Mediatore*. The correctness of this list was denied by the organs of the other party, although it was generally admitted that there were associations of priests in Milan, Florence, Naples, and elsewhere, who sympathized with Passaglia, and a part of whom demanded, besides the abolition of the temporal power, the introduction of other changes.

Outside of Italy this movement found but little support. In Paris, two papers are published, *L'Observateur Catholique* and *l'Unité Chrétienne*, which, while claiming to remain Catholic, strongly reject the temporal power, the infallibility of the Pope, the doctrine of the immaculate conception, and other doctrines and views generally held by the church, and advocate a union with other churches holding the apostolical succession of bishops; but it does not seem that they represent a considerable party.

The Roman Catholic church has for some time made considerable progress among the eastern churches of Turkey, and during the past year large accessions have been again reported to each of the united eastern churches, which, while retaining the language and rites of their former communions, have adopted the doctrines of the Roman Catholic church. Of the most recent origin among these united churches is the United Bulgarian church, which originated in 1859, and received in 1860 the first bishop, Sokolski. This bishop, after some

time, suddenly and mysteriously disappeared, and it was asserted that he had been carried off from Constantinople against his will by the Russians, and was now retained by them in a Russian convent. The United Bulgarian church has since received from the Pope a patriarch at Constantinople, and an archbishop at Philippopolis. They have been recognized by the Turkish Government as a political community, but they cannot take with them to the new church the edifices in which they formerly worshipped. These remain to the Greek church, and the Bulgarian congregations that wish to join the new United Bulgarian church have to build new chapels. On Dec. 9th, 1862, the Bulgarian archbishop of Sophia applied for admission to the communion of the Roman Catholic church, and the same application was made a few days after by the assistant bishop of Adrianople, but according to the statement of Roman Catholic papers, both applications were refused because it was found out that they had been made from mercenary motives. The United Bulgarians are chiefly numerous in the province of Adrianople, where their total number in April, 1862, was stated to be 2,612 families.

It is also reported that numerous congregations of the Greek church have entered during the year 1862 into communion with the Roman Catholic church in the plain of Damascus, and in the country between Lebanon and Balbeck. At the head of this movement is the former Greek bishop of the town of Holms. He has solemnly joined the Roman Catholic church, and as he is a man of great influence in Syria, it is believed that many will follow his example. A particular zeal for the interests of the Roman Catholic church in Syria is displayed by the Paris "Association for establishing Christian schools in the East." The bulletin of this society claims that more than four thousand schismatics, among whom were several priests, have already joined the communion of Rome, and that many others are on the point of following them.

While thus, according to all accounts, the Roman Catholic church is making considerable progress among the Bulgarians, Greeks, Armenians, and other Eastern churches, it is reported by a missionary of the English church missionary society, that nearly the whole United Syrian church in Travancore, India, has seceded from the communion of the Roman Catholic church. This body, which counts about 97 churches and a population of 96,000 souls, is reported to have sent a deputation to the Jacobites (Monophysites) of Syria. The bishops of the latter sect consecrated one of the delegates a bishop, who on his return to Travancore declared for a separation from Rome. With but few exceptions, writes the English missionary, the members of the Syrian church gave in their adherence to the new bishop, and the Roman Catholic bishop was left with no more than 10 or 12 parishes. No account of this

movement had, however, up to the end of the year been received from Roman Catholic sources.

ROSS, Admiral Sir JAMES CLARK, D.C.L., F.R.S., F.L.S., an English naval officer and polar voyager, born in London, April 15, 1800, died at Aston Abbott's House, Aylesbury, April 8, 1862. He was a nephew of the late Sir John Ross, and entered the navy in 1812, as a volunteer on his uncle's ship, and between 1818 and 1827 accompanied his uncle and Commodore Parry in 5 voyages of exploration to the arctic regions. In 1827 he was made a commander, and in 1829 joined Sir John Ross's arctic expedition, which was detained for four years in the polar regions. During this expedition, in 1831, he discovered the north magnetic pole, and planted the British flag upon it, and on his return in 1834 was raised to the rank of post-captain. In 1836, he crossed the Atlantic to search for and relieve some missing whale ships, and after his return was engaged for two or three years on a magnetic survey of Great Britain and Ireland. In 1839 he took command of the antarctic expedition, and in his four years' cruise approached within 160 miles of the South magnetic pole. In 1844 the University of Oxford bestowed on him the honorary degree of D.C.L. He had been elected a fellow of the Linnean Society in 1823, and of the Royal Society in 1827, and was also a corresponding member of many of the foreign scientific societies. For his discoveries in his antarctic expedition he received the gold medals of the London and Paris Geographical Societies. He made an independent discovery of the antarctic continent, though a few months later than Com. Wilkes. In 1844 he was knighted. In 1848 he was appointed to the *Enterprise* and made a voyage to Baffin's Bay in search of Sir John Franklin. He published in 1847 a narrative of his antarctic explorations under the title of "A Voyage of Discovery and Research in the Southern and Antarctic Regions." (3 vols. 8vo, London.)

RUSSIA, an autocratic empire of Europe and Asia, having in Europe a territory of 2,120,397 square miles, and a population in 1861 of 66,891,493 inhabitants. Emperor, or Czar, Alexander II, born in 1818, ascended the throne in 1855. Estimated revenues for 1862, \$245,571,150, including about \$75,000,000 to be derived from a loan; estimated expenditure for the same year, \$231,771,150.

At the beginning of 1862, two topics occupied the thoughts of the Russian people, and of the nations adjacent who were interested in Russian affairs; viz., the condition of Poland, and the effects of the promised emancipation of the serfs. Other topics allied to one or the other of these, became prominent in the course of the year, which has been for Russia one of the most eventful of her history.

The Poles, who had resolved to assemble at Warsaw on the 15th of Oct. 1861, to celebrate the memory of Kosciusko, were prevented from

making the demonstration they had intended by the Russian authorities, who on the day preceding declared the city in a state of siege, and stationed a large body of troops in the streets. The people nevertheless assembled in the churches peaceably. When they were filled, the soldiers surrounded them and commanded the people to go to their homes; this was refused quietly but steadily, unless the soldiers would first withdraw; and for 17 hours they remained in the churches, singing national hymns; finally, the Russian general Gerstenweig, a Russian of the old type, gave the order to the soldiers to take them out of the churches by force at 4 o'clock in the morning. The soldiers obeyed and dragged away more than 2,000, many of them women and children, to the citadel. This order of the general, given without consultation with the Governor of Warsaw, Count Lambert, led to a violent altercation between the latter and the general, which terminated in the latter committing suicide, and the former leaving Warsaw the next day, on the plea of ill health.

The proceedings of the 15th were followed by other arrests, and by the imprisonment, banishment, and condemnation to death of prominent Poles, and the Russian Government, as it has often done, alternated acts of mildness and severity, in such a way as to lose the confidence of all parties of Warsaw, and to give the impression of a vacillating and timid policy, cruel when it was safe to be so, and only gentle when the threatened uprising of the whole people inspired it with alarm. In the appointment of a new archbishop, the former archbishop having died in the summer of 1861, the emperor, who nominated the new incumbent, showed a desire to gratify the Poles, and to efface the remembrance of his past despotic acts; as he did also in the appointment of his brother the Archduke Constantine as his lieutenant of Poland, in May, 1862; but the Poles had been too often cajoled, and then treated with cruelty, to be readily placated. The Russian general, Luders, Count Wialopolski, the Governor of Warsaw, and the archduke himself were repeatedly attacked by assassins, and the general and the archduke severely wounded. These assailants were arrested, tried, and executed. After some months quiet seemed in a fair way of being restored, when the Russian Government was again guilty of one of those acts of tyranny which every few months excite the Poles to insurrection and resistance. The conscription for the ensuing year was to be made in November, 1862, and instead of proceeding as the law required, and as was practised in Russia, throughout Poland the citizens of the towns, who had been more active than the peasants of the country in their opposition to the Government, were seized for the army, and every man who had united in singing the national hymns, whether beyond military age or not, and without regard to his social position or circumstances, was put at once into the ranks,

as a common soldier, and informed that the Polish contingent was to be sent to Siberia for military service. This gratuitous cruelty led at once to a general insurrection, which in April, 1863, had not been fully repressed.

The promised emancipation of the serfs, announced by the Czar in his proclamation of February, 1861, to be consummated in two years, was a measure which, though reflecting much credit on its projectors, and fraught with future benefits for Russia, was involved in great difficulties of detail. The serfs comprised considerably more than one half of the population of the European portion of the empire, and were, the agricultural portion of them at least, attached to the soil, and could only be sold with it. Hence they had come to regard the soil as belonging to them, while they acknowledged themselves the serfs of their masters. Among the provisions of the code drawn up for the regulation of the future relations between masters and serfs, was one which required the serf to work for his master on low wages till the expiration of the two years, and previous to that time to negotiate with the landholders for the purchase at a certain price (to be fixed by disinterested appraisers) of the fee simple of the land, which they were henceforth to own themselves. The serfs, who, though ingenious in mechanical inventions, are very slow to understand legal or constitutional matters, in many districts refused to work for the boyars or landed proprietors, or to make provision for the payment for the lands, alleging that they already belonged to them, or that the Emperor would pay for them. On the other hand the boyars, who by the refusal of the serfs to work or to purchase their lands were likely to be reduced to poverty, were disposed to resist the decree. In some of the governments armed bodies of the serfs assembled and committed violence, and were only reduced to order by considerable loss of life. The serfs who were not attached to landed estates, also had their difficulties, and in some instances engaged in *emeutes*, but on the whole, there was perhaps less trouble than was to be expected. The freedom of the serfs was to date from February, 1863, but they were not to come into full possession of their lands, in most instances, free from incumbrance till the expiration of seven or nine years. The serfs of the crown, whose condition had been much superior to that of the serfs on private estates, were also to be liberated by the Emperor at the same time with the others and to pay for the lands in instalments, the Government giving them liberal terms both as to time of payment and the price of their lands.

The feeling pervaded all classes in Russia, on the announcement of the Emperor's determination to emancipate the serfs, that a measure involving such changes in the principles on which the Government was founded, was but a preliminary step to other and equally radical changes in the political management of

the empire, which should transform it into a limited and constitutional monarchy. The Emperor, if he had formed any such plans, did not immediately reveal them, and, indeed, repressed, though with an apparently vacillating purpose, any manifestations of a desire for greater freedom.

The students of the universities of St. Petersburg, Moscow, and Kasan, and the academy of military engineering at St. Petersburg, had since the accession of Alexander II to the throne, enjoyed greater liberty than under the stern and despotic rule of his father; and they had improved their opportunities to establish libraries, aside from those of the universities, mutual aid societies to help the poorer students, and to discuss the questions of state policy. The minister of public instruction, M. Kovalefsky, was supposed to favor these developments of youthful freedom, and he was removed, and the Admiral Putiatin, a reactionary officer, put in his place. His first acts were the closing of all the female seminaries, the advance of the charges at the universities to \$160 per year, in order to exclude the poorer students; and the dismissal of the ablest and most liberal professors. By the second of these measures over 600 students were at once excluded from the university of St. Petersburg, and a larger number from the other universities. The dismissal of the professors led to protests on the part of the students, for which many of them were imprisoned, their libraries confiscated, and the universities closed. The Polish students, affected by the condition of Poland, and the massacres at Warsaw, chanted requiems for the dead, and the Polish national hymn, "Poland is not Dead," and many of the Russian students sympathized with them. The Poles were arrested and imprisoned, and 600 of the Russian students petitioned the Emperor to be allowed to share their fate, but received no reply. M. Putiatin, not satisfied with having closed the female seminaries and the universities, proceeded to shut up also the scientific schools, and the private schools and Sunday schools of the empire. In Moscow the conflicts between the students and the authorities led to some bloodshed, and many of the students were banished or consigned to unwholesome prisons at Perm, Archangel, Viatka, Vologda, and Olonetz, where they died of typhus fever. Admiral Putiatin was finally removed by the Emperor, and M. Golownin appointed in his place, who, though not fully a liberal in his views, reopened the universities and schools, and undid a part of the mischiefs of his predecessor.

But it was not the students alone who were thus excited by the radical changes proposed by the Emperor. The press also demanded a relief from censorship, and a liberty of utterance befitting a free people, and was disposed to take, ere the Emperor was ready to grant, that which it asked for. The Constituent Assemblies of the different governments, which

met in the latter part of January, 1862 (the Russian empire is divided into 88 governments and provinces), whose discussions had usually been confined to local matters of finance, the management of the communes, or sanitary topics, at their sessions at this time took up questions of greater importance, and voted addresses to the Emperor, demanding local self-government, publicity of legal processes, the yearly publication of the budget, the liberty of the press, and the assembling of the General Assembly at Moscow, composed of representatives of all classes, which should be charged with the preparation of a plan of reform for the Government, or, in other words, a constitution. The Constituent Assembly of Moscow adopted this address by a vote of 300 out of 362 members. The Assembly of Twer went farther; they declared that the official regulations concerning emancipation were impracticable, and should be modified; that the liberated serfs should immediately become proprietors, by means of purchase of lands, in which they should be assisted by the Government; that the nobility of that Government (the Constituent Assembly was mainly composed of nobles) renounced its privileges of freedom from taxation, and asked to be taxed in the same way and on the same principles as the peasants, and urged the necessity of calling a National Assembly, composed of representatives of all classes to form a constitution.

The Government was not prepared for such demonstrations on the part of the people, and did not respond very cordially to them, although the Emperor was undoubtedly deeply impressed with the sentiments of the addresses. On the 29th of September, O. S. (October 11), the Emperor promulgated a decree, in which, while withholding as yet the asked for National Assembly, he grants other reforms of a very important character, and even some which had not been directly sought. Among these are the taking away from the police all judicial power (which has hitherto been one of the greatest of abuses), and vesting the judicial authority, in petty cases, civil and criminal, in civil magistrates or justices of the peace, elect-

ed every three years by the people; more important cases are to be decided by district tribunals, composed of judges appointed by the Emperor, at the nomination of the minister of justice, of whom three at least must be present at the trial of every cause. All civil and criminal cases are tried before a jury taken from all classes of the population, eligibility depending upon age, residence, property, and general intelligence and morality. The state is represented by a prosecuting attorney, and both plaintiff and defendant may employ advocates. A majority of the jury decide the case. In cases where the judges unanimously consider a person innocent, whom the jury pronounce guilty, they have the right to refer the case to another jury; but the verdict of the second jury shall be final. The directing senate constitutes the high court of appeal, which may refer the case back for trial to another tribunal of equal rank, whose decision shall be final in all cases. Imprisonment for debt for sums less than \$80 (100 rubles) is abolished, and in no case can a debtor be imprisoned over five years. All legal distinctions, resulting from social conditions, are abolished, all domiciliary visits, searches under warrant, and seizures must be made in the presence of witnesses. All persons arrested, upon whatever charge, must positively be examined within 24 hours, and the classes who would suffer from personal detention are exempted from it. Crimes against the state, against religion, or committed by government officers in the exercise of their functions, are not tried by the courts above described, but by special courts, and the mode of procedure is so arranged that the Emperor is relieved from the personal examination of these cases, and the necessity of a system of espionage, which has hitherto been the curse of Russian society, is obviated. These measures, if honestly and fully carried out, will be the beginning of a new era in the history of Russia, and will fully entitle her, as she enters upon the second thousand years of her history (the thousandth anniversary of the founding of the empire was celebrated in 1862) to a high rank among the civilized nations of the world.

## S

**SAN MIGUEL, EVARISTO**, a Spanish general and statesman, born in the Asturias in 1780, died in Madrid, May 29, 1862. He volunteered in the war against the French in 1808, and from his energy and military ability was soon promoted to the rank of lieutenant-colonel, and elected a member of the Cortes from Cadiz. After the restoration of Ferdinand VII, he was placed on the retired list, and not long after founded the *Espectador* newspaper, in which he advocated with great ability a constitutional government. In 1820, when the tyranny of Ferdinand had utterly extinguished the hopes

of all the friends of a constitutional government in Spain, and Riego raised his Andalusian expedition, San Miguel joined him as chief of staff, and at that time composed the "Hymn of Riego," one of the most popular of Spanish war songs. The expedition was unsuccessful, and in 1821 San Miguel was exiled to Zamora. But the tyrant found himself unable to stem the tide of public feeling, and in 1822 was compelled to accept a liberal ministry. The exile was recalled and offered the post of Minister of Foreign Affairs in the new cabinet, which he accepted. The time was a critical one. Austria,

France, Prussia, and Russia had each bound themselves in the Congress of Verona to put down all liberal movements among the monarchies of the Continent; and each power addressed a note to the Madrid cabinet, summoning it to return to the old system. To these notes San Miguel replied in a manner which indicated alike the strength of his devotion to liberal principles and his intellectual ability in defending them. He gave the history of the liberal movement, showed that the present constitution had been recognized by the Emperor of Russia in 1812, that they professed the right to manage their own affairs, and denied the right of other powers to intermeddle, and concluded with the declaration that his Majesty's Government would not deviate a hair's breadth from the line which national honor and its unvarying adhesion to the constitution of 1812, which it had sworn to observe, had traced out for it. The Holy Alliance was astonished; but it had gone too far to recede. The ambassadors of the four powers were withdrawn, and France took the lead in the work of attempting to crush out constitutional freedom. A long war ensued, and San Miguel, as brave in the field as in the cabinet, joined the army in Catalonia, and greatly distinguished himself in almost every engagement of the next three years. He was repeatedly wounded, in 1826 so severely that his recovery seemed almost a miracle, and finally taken prisoner, but soon after released on condition of quitting Spain. The next 8 years of his life were spent in honorable exile in England, and he did not return to his own country till the amnesty proclaimed by the queen regent in 1834 restored him to his rights. Soon after his return, he was appointed by the queen Captain-General of Aragon, and elected a Deputy to the Cortes. In 1842, under the regency of Espartero, he was appointed Captain-General of the Basque Provinces, and after the fall of the regent in 1843, retired into private life, and resided chiefly in Madrid. In 1847, he published a History of Philip II, on which he had been for some years engaged. In 1854, he was again called into public life, on the overthrow of the Sartorius Ministry, being named by the queen Captain-General of Madrid and Minister of War. For some time he was in effect universal minister, Espartero not having arrived, and none of his colleagues being efficient. In July he was named President of the Junta, and in that position controlled and held in check both O'Donnell and Espartero. He was, at the close of the revolution, raised to the rank of field marshal, and having been elected to the constitutional Cortes, was for some time its president. In 1856, he was made a grandee of the first class, and appointed Commandant General of the Household Guard. As a grandee, he took his seat in the Senate in 1857, when he supported a liberal government to the last. He was greatly esteemed in private life for his probity and amia-

bility. Beside the History above named, he was the author of several other works, mostly relating to the wars of his time.

SLAVES. The questions relative to the political, civil, and social position of negroes, or "colored persons of African descent," as they were designated by Congress and the executive officers of the Federal Government, became more prominent during 1862 than in any previous period. An elaborate opinion was prepared by the U. S. Attorney-General, Mr. Bates, on the question "are colored men citizens of the United States?" The chief points of the opinion were—that the Constitution does not define the word citizen, the Attorney General therefore examines history and the civil law from the existence of the Roman Empire to the present day to discover its meaning. His conclusion is—that all free persons, without distinction of race or color, if native born, are citizens. A distinction is made between the inherent rights of citizens and the political privileges of certain classes. All citizens have a right to protection, but only certain classes enjoy the privileges of voting and holding office. Hitherto not only the public but jurists have often confounded the two. A child or a woman is a citizen, though not always privileged to vote or hold office. The Dred Scott opinions are pronounced void and of no authority, since the province of the Supreme Court was only to settle the questions of the jurisdiction of the Circuit Court. They are simply entitled to the respect due to the views of eminent gentlemen, and no more. The paper concludes as follows:

"And now, upon the whole matter, I give it as my opinion that the free man of color mentioned in your letter, if born in the United States, is a citizen of the United States, and, if otherwise qualified, is competent, according to the acts of Congress, to be master of a vessel engaged in the coasting trade."

The same general question was raised by the Secretary of State in referring an application for a passport by a negro to the Attorney General.

In Massachusetts the governor, Andrew, ordered negroes to be enrolled as well as white persons for the purpose of drafting soldiers. The Attorney General of the State justified the order on the ground that—"Congress and the war department both leave out the word *white* from the description of the class to be enrolled." He further adds: "The only possible question now open is whether colored men are citizens of Massachusetts, which no one, I presume, will have the hardihood to deny, inasmuch as they are tax-payers, voters, jurors, and eligible to office, and there is no inequality founded on distinction of races known to our laws."

On the other hand the Circuit Court of Illinois sitting in Montgomery county decided that negroes were not citizens. In this case the complainant filed his bill to enjoin the payment to

the defendant, W. C. Lowry, who was alleged to be at least one fourth negro, by the trustees of a school district, the sum of one hundred and fifty dollars, which a majority of them agreed to pay him as compensation for teaching a common school in the district for six months. The trustees admitted the charges of the bill, but stated that they had no knowledge of the fact charged and did not believe it.

The defendant Lowry denied under oath that he was of African descent or that he had any African blood in his veins, but declined to offer evidence that he was not a mulatto, and made no attempt to sustain his answer by proof. The complainant and others refused to send their children to said Lowry, and offered a number of witnesses who stated they were well acquainted with the African race, and believed the defendant mixed with African blood. The evidence, in the absence of any testimony to the contrary, being in the opinion of the Court sufficient to establish the allegation in the bill that the defendant, Lowry, was at least one fourth negro blood, the simple question remained, is it competent for directors of schools, under their common school system, to appropriate the common school fund raised by taxation to the payment of persons of color as teachers in the public schools? In the opinion of the Court no such use could be made of the common school fund by the agents of the corporations created for school purposes. The Court said:

While it is admitted that persons of color are capable of contracting, and further, that there is by statute no express prohibition as to the employment of persons of that class as teachers in the public schools of the State, we think it clear that the spirit of legislation in this State, with reference to negroes, as well as good taste and sound public policy, forbid it.

The Constitution of this State, and the statutes adopted in pursuance thereto, forbid the migration to and settlement in this State of such persons. They are forbidden to vote, sit upon juries, hold office, and to testify in causes where white persons are parties. Especially by the common school law of this State are negro children prohibited from attending as pupils and enjoying the benefits of schools established for the benefit of white children. No doubt, had the Legislature conceived it probable that an attempt would ever be made to place negroes in the delicate and almost parental relation of teachers of the white children of the country in the public schools, they would have inserted an express provision against it. We think, however, enough is shown to demonstrate the fact that the Legislature intended that the races should be separate in the public schools beyond any reasonable doubt. It would also seem that any attempt to appropriate the public school funds to such a use is an abuse, and an assumption of power wholly unwarranted, against which the tax-payers interested ought to have relief.

A decree is therefore granted according to the prayer of the bill.

In the same State indictments were found in the Jersey County Court against officers of the State troops who returned from the army at the South and brought negroes with them. The penalty was a fine of from one to five hundred dollars and imprisonment in the county jail not more than one year.

VOL. II.—48 A

The manner in which the Navy Department regarded the negro is shown by the following order:

NAVY DEPARTMENT, April 30, 1862.

"Sir—The approach of the hot and sickly season upon the Southern coast of the United States renders it imperative that every precaution should be used by the officers commanding vessels to continue the excellent sanitary condition of their crews. The large number of persons known as 'contrabands' flocking to the protection of the United States flag affords an opportunity to provide in every department of a ship, especially for boats' crews, acclimated labor. The flag-officers are required to obtain the services of these persons for the country by enlisting them freely in the navy, with their consent, rating them as boys, at eight, nine, or ten dollars per month, and one ration. Let a monthly return be made of the number of this class of persons employed on each vessel under your command.

"I am, respectfully, your obedient servant,  
"GIDEON WELLES."

On an application by a citizen of North Carolina to the naval commander Rowan for a favorite servant supposed to be with the United States forces, the Secretary gave the following instructions:

As similar applications may frequently be made, it is proper to remind you that persons who have enlisted in the naval service cannot be discharged without the consent of the Department, and that no one should be "given up" against his wishes.

The social position of the negro is illustrated by many facts which occurred. The following correspondence will serve to show their position in the army:

TRENTON (TENN.), August 12, 1862.

Geo. W. Deitzler, Col. Com'ding First Regt. Kan. Vols.

We, the undersigned, non-commissioned officers and privates of Company G, First Regiment Kansas Volunteers, respectfully request that Francisco Adalger, of the above company, be transferred to the original company to which he was assigned or be mustered out of the service. Our reasons are—firstly, we believe him to be a "nigger;" secondly, that he never was properly assigned to our company, but, after being refused in several other companies, he was placed in Company G. We have no objection to giving our services to our country, to endure all the privations that we may be called on to endure, but to have one of the company, or even one of the regiment, pointed out as a nigger while on dress parade or guard, is more than we like to be called upon to bear.

We hope that the above will meet your hearty approval.

[Signed by thirty-six of the company, and endorsed as follows:]

HEADQUARTERS UNITED STATES TROOPS, }  
TRENTON (TENN.), August 14, 1862. }

Brig.-Gen. G. M. Dodge, Commanding Division.

GENERAL: The person referred to in the within protest was transferred, together with eighty-four others, to the regiment from the First Kansas and New Mexico Regiment, by order of the Governor of Kansas, and assigned to Company G. He is full two thirds "nigger"—too black to serve upon terms of equality with white soldiers. I respectfully recommend that he be mustered out of service, or transferred to Jim Lane's nigger brigade. The recommendation is not made out of disrespect for the nigger.

GEORGE W. DEITZLER,

Col. First Kansas Vols., Commanding Post.

In the month of July disturbances broke out in various parts of the country, arising from apprehensions that the negroes who have in-

creased largely in numbers in all the Northern states since the commencement of the war, were about to be put upon a footing of equality. In Chicago, at a public meeting of the workmen of the leading slaughter and packing houses, the following preamble and resolution were adopted:

*Whereas* it has come to the knowledge of this meeting that it is the intention of one or more of the leading packers of this town to bring negro labor into competition with that of the white men, for the purpose of reducing the wages of the latter to the lowest possible standard:

*Resolved*, That we, the packing-house men of the town of South Chicago, pledge ourselves not to work for any packer, under any consideration, who will, in any manner, bring negro labor into competition with our labor.

In Brooklyn, N. Y., on the 4th of August, a disturbance took place between Irish laborers and negroes, in which the former demanded that the latter should be discharged from the tobacco manufactories. This was done. The military on this occasion were called to aid the police. It was stated that the facility with which negroes gained employment at the navy yard, custom house and other public places, increased the ire of the assailants. Similar disturbances took place at Cincinnati and Toledo, Ohio, and New Albany, Indiana.

The social position of the negro in all the Northern or free States is similar to his position in Ohio as described by the Senator from that State in Congress—Sherman—in these words:

"The negro race is looked upon by the people of Ohio as a class to be kept by themselves; to be debarred of social intercourse with the whites; to be deprived of all advantages which they cannot enjoy in common with their own class. They have always been deprived of the elective franchise in this State; and no party among our citizens has ever contemplated that they should be given that right of citizenship; and, for aught that appears to the contrary, the colored man in Ohio will not, in all future time that he may remain an inhabitant of the State, attain any material improvement in the social or political rights over what he now enjoys. Deprived of the advantages here enumerated, it could not be expected that he should attain any great advancement in social improvement. Generally, the negro in Ohio is *lazy, ignorant, and vicious*. But it is only fair to acknowledge that almost any race, in similar circumstances, would be reduced to about the same level. Deprived of liberty, social and political rights, for centuries, it is unreasonable to expect an improved state of society."

The operations of the Federal forces within slaveholding States necessarily released many slaves from the restraints of their masters. The mass of them took advantage of this circumstance to escape from servitude. Their presence within the Federal lines led to the adoption of various measures by the Commanding officers and by the Federal Government relative to them, all looking toward their ultimate freedom. For the action of the Government on the subject of emancipation see UNITED STATES.

In January the Marshal of the District of Columbia was instructed by order of the President "not to receive into custody any persons

claimed to be held to service or labor within the District, or elsewhere, and not charged with any crime or misdemeanor, unless upon arrest or commitment, pursuant to law, as fugitives from such service or labor, and not to retain any such fugitives in custody, beyond a period of thirty days from their arrest and commitment, unless by special order from the civil authority." The effect of this order was to relieve from any fears of apprehension all the fugitives that had escaped to the District from Virginia. Thousands of slaves flocked to the District and were sustained throughout the year by rations furnished by the Government.

In Missouri, General Halleck had, previous to this time, issued an order that fugitive slaves should not be permitted to enter the lines of any camp, or any forces on the march. This order occasioned much discussion, especially in Congress, as it cut off an opportunity for escape to thousands of slaves. It was explained by Gen. Halleck in these words, "unauthorized persons, black or white, free or slave, must be kept out of our camps, unless we are willing to publish to the enemy every thing we do, or intend to do."

In Arkansas, Gen. Curtis issued orders of immediate emancipation under confiscation of a number of slaves who had been at work for the Confederate Government by the consent of their masters.

Similar orders were issued by Gen. Hunter, under like circumstances in the Department of South Carolina. These were extended until he at length issued an order confiscating and emancipating all the slaves in his military district, embracing South Carolina, Georgia, and Florida. This was countermanded by the President. (See PUBLIC DOCUMENTS.)

At Baton Rouge, in Louisiana, Brig.-Gen. Williams issued an order that, in consequence of the demoralizing and disorganizing tendencies to the troops of harboring runaway negroes, the commanders should turn all such fugitives beyond the limits of their respective guards and sentinels. Col. Paine of this brigade refused obedience and justified himself by the following act of Congress:

"Be it enacted by the Senate and House of Representatives of the United States of America in Congress assembled, That hereafter the following shall be promulgated as an additional article of war for the government of the Army of the United States, and shall be obeyed and observed as such:

"ART. —. All officers or persons in the military or naval service of the United States are prohibited from employing any of the forces under their respective commands for the purpose of returning fugitives from service or labor who may have escaped from any person to whom such service or labor is claimed to be due, and any officer who shall be found guilty, by a court-martial, of violating this article shall be dismissed from the service.

"SEC. 2. And be it further enacted, That this act shall take effect from and after its passage."

In North Carolina an appeal was made to Gov. Stanley by some masters for the restora-

tion of their slaves. In one instance this was granted, but the slave was rescued by the soldiers, and the master's property destroyed. It occasioned so much censure of the conduct of Gov. Stanley among the friends of the Administration, that the Secretary of War found it necessary to deny that the act was in accordance with the instructions to the governor.

The effect of all the regulations adopted, except in Missouri and Baton Rouge, was to secure freedom to every slave that would make the effort to obtain it. Wherever permanent headquarters for Federal troops were established within slaveholding States, they soon became crowded with hundreds and thousands of fugitive slaves. The Government was immediately obliged to feed them or starvation would ensue. At Washington, at Fortress Monroe, Newbern, and Port Royal were large numbers furnished with quarters and fed at the national expense. Various schemes were devised for the occupation of these negroes, particularly in the department of South Carolina. The following were the instructions originally issued to the commander of that department :

WAR DEPARTMENT, Oct. 14, 1861.

SIR: In conducting military operations within States declared by the proclamation of the President to be in a state of insurrection, you will govern yourself, so far as persons held to service under the laws of such States are concerned, by the principles of the letters addressed by me to Maj.-Gen. Butler on the 30th of May and the 8th of August, copies of which are herewith furnished to you. As special directions, adapted to special circumstances, cannot be given, much must be referred to your own discretion as commanding general of the expedition. You will, however, in general, avail yourself of the services of any persons, whether fugitives from labor or not, who may offer them to the National Government. You will employ such persons in such services as they may be fitted for, either as ordinary employés, or, if special circumstances seem to require it, in any other capacity, in such organization, in squads, companies, or otherwise, as you may deem most beneficial to the service. This, however, not to mean a general arming of them for military service. You will assure all loyal masters that Congress will provide just compensation to them for the loss of the services of the persons so employed. It is believed that the course thus indicated will best secure the substantial rights of loyal masters and the benefit to the United States of the services of all disposed to support the Government, while it avoids all interference with the social systems or local institutions of every State beyond that which insurrection makes unavoidable, and which a restoration of peaceful relations to the Union, under the Constitution, will immediately remove.

Respectfully,

SIMON CAMERON,  
Secretary of War.

On the 6th of February, Gen. Sherman, then in command, issued an order relative to the fugitive slaves, in which he said:

Until proper legislation on the subject, or until orders from higher authority, the country in occupation of the forces of this command will be divided off into districts of convenient size for proper superintendence. For each of these districts a suitable agent will be appointed to superintend the management of the plantations by the blacks, to enroll and organize the willing blacks into working parties, to see that they

are well fed, clad, and paid a proper remuneration for their labor; to take charge of all property on the plantations, whether found there, provided by the Government, or raised from the soil, and to perform all other administrative duties connected with the plantations that may be required by the Government. A code of regulations on this subject, as well as a proper division of districts, will be furnished in due time.

In the mean while, and until the blacks become capable themselves of thinking and acting judiciously, the services of competent instructors will be received—one or more for each district—whose duties will consist in teaching them, both young and old, the rudiments of civilization and Christianity—their amenability to the laws of both God and man—their relation to each other as social beings, and all that is necessary to render them competent to sustain themselves in social and business pursuits.

Subsequently the Secretary of War, without any authority from Congress, and without the knowledge of the people, issued orders, which developed the following plan for a social experiment with the negroes:

HEADQUARTERS, E. C., HILTON HEAD, S. C., }  
March 3, 1862. }

General Order, No. 17.

1. Mr. Edward L. Pierce having been appointed by the Hon. Secretary of the Treasury General Superintendent and Director of all persons engaged in the cultivation of the land and the employment of the blacks, he is hereby announced as such.

2. The following instructions to the general commanding are hereby published for the information of all concerned; and commanding officers of all posts and stations within the limits of this command, will be governed in strict conformity thereto.

WAR DEPARTMENT, Feb. 13, 1862.

To Gen. T. W. Sherman, Commanding at Port Royal, S. C.:

GENERAL: You are hereby directed to afford protection, subsistence, and facilities, so far as may be consistent with the interests of the service and the duties and objects of your command, to all persons who may present to you written permits, issued to them under the authority of the Secretary of the Treasury, setting forth that said persons have proceeded to Port Royal under the sanction of the Government, for the collection, safe keeping, and disposition of cotton, rice, and other property abandoned by the possessors within your military department, and for the regulation and employment of persons of color lately held to service or labor by enemies of the United States, and now within the occupying lines and under the military protection of the army.

Such permits, signed by the Collector of Customs at New York city, will be considered by you as emanating from the Treasury Department.

Under the head of subsistence will be included rations to such persons as may be employed under the direction of the Treasury Department, in the temporary charge of the abandoned plantations; or, with its sanction, to labor for the instruction and improvement of the laboring population.

EDWIN M. STANTON, Secretary of War.

To L. H. Pelouse, Captain 15th Infantry, Acting Assistant Adjutant-General:

3. No quarters, hospitals, storehouses, or other public buildings, however temporary, will be erected within the limits of this command, without previous sanction and order of the general commanding.

When any temporary building is proposed to be erected, a plan and specification of the same will be sent to the chief quartermaster for the examination and consideration of the general commanding.

Brig.-Gen. T. W. SHERMAN.



## NOMINATION OF INSTRUCTORS AND MANAGERS.

To *Hiram Barney, Esq., Collector of the Port of New York.*

NEW YORK, —, 186 .

SIR: On the nomination of —, I, the undersigned, do hereby recommend — as suitable persons to receive your permit to proceed to Port Royal, in the State of South Carolina, for the purpose of assisting in the instruction and management of the negroes within the lines of the United States army, at Port Royal and its vicinity.

Respectfully, yours,

## PERMIT OF THE COLLECTOR FOR KEEPING OF COTTON.

CUSTOM HOUSE, NEW YORK, COLLECTOR'S }  
OFFICE, —, 186 . }

In pursuance of authority vested in me by the Secretary of the Treasury, I, Hiram Barney, Collector of the Port of New York, do hereby permit — to proceed from the city of New York to Port Royal, in the State of South Carolina, on board of any vessel in the employment of the United States, carrying passengers to the latter place.

The said — proceeds to Port Royal under the sanction of the Government of the United States, upon business relating to the collection, safe keeping, and disposition of cotton, rice, and other property abandoned by persons inhabiting any district within the late territorial limits of States declared by proclamation of the President to be in insurrection against the United States; and also upon business relating to the condition and employment of persons of color at Port Royal and its vicinity, lately held to service or labor by the enemies of the United States, and now within the limits and under the military protection of the army of the United States.

The transportation of the said — is to be in — of the vessel on which he may sail, and it will cover all baggage belonging to him; and also —.

This permit is given upon the express condition, that the holder is to obey all rules and regulations established by the Treasury Department, or the military or naval authorities at Port Royal, and its vicinity; and also all other rules and regulations established by the aforesaid authorities at any and all places he may visit. This permit is to become void if transferred by the holder to any other person, either permanently or temporarily.

On receiving this permit, the said — took the oath of allegiance as prescribed by the act of Congress.

For the purpose of identification, and as proof that he receives this permit for the above mentioned purpose, and on the above named conditions, the said — has written his name hereon.

In witness whereof, I have hereunto set my hand the day and year above written.

Signature of holder. —, Collector.

## PERMIT FOR INSTRUCTING NEGROES.

CUSTOM HOUSE, NEW YORK, COLLECTOR'S }  
OFFICE, —, 186 . }

In pursuance of authority vested in me by the Secretary of the Treasury, on the 24th day of February, 1862, I, Hiram Barney, Collector of the Port of New York, do hereby permit — to proceed as a — passenger, with his baggage, from the city of New York to Port Royal, in the State of South Carolina, on board of any vessel in the employment of the United States, carrying passengers to the latter place.

This permit is given upon the express understanding and condition, that the said — proceeds to Port Royal for the purpose of assisting in the instruction and management of the negroes within the lines of the United States army at Port Royal and its vicinity; and upon the further condition that he shall obey all rules and regulations established by the Treasury Department or the military or naval authorities at Port Royal and its vicinity, in regard to said negroes, and the persons engaged in their instruction and man-

agement; and all other rules and regulations established by the aforesaid authorities at any and all places which he may visit. This permit is to become void if it is transferred by the holder to any other person, either permanently or temporarily.

For the purpose of identification, and as a proof that he receives this permit upon the conditions above mentioned, the said — has appended his name hereto.

On receiving this permit, the said — took the oath of allegiance as prescribed by act of Congress.

In witness whereof, I have hereunto set my hand, the day and year first above written.

Signature of holder. —, Collector.

Several societies undertook to take charge of the matter, and seventy-two persons, farmers, mechanics, physicians, and teachers, were sent out by the Government, receiving each one ration a day from the commissariat, and paid salaries by the affiliated societies. They were "to teach Christianity and civilization to the freed men of the colored race, to imbue them with notions of order, industry, and economy, and self-reliance, and to elevate them in the scale of humanity, by inspiring them with self-respect." The cost of rations to the Government, a part of which were consumed in this experiment, was estimated at \$100,000 per day. Educational associations were formed in Boston and other places, by whom the teachers were procured. On the 2d of June, the Agent, E. L. Pierce, made a report to the Secretary of the Treasury, Mr. Chase, in which he stated that seventy men, and sixteen women, were engaged in missionary work among the negroes, under the auspices of the Treasury Department. The number of plantations under the care of these persons was 189, having on them 9,050 Africans, classified as follows: 809 mechanics and house servants, 698 old, sickly, and unable to work, 3,619 children, not useful for field labor, 4,429 field hands, of whom 3,202 were full hands, 295 three-quarter hands, 597 half hands, and 835 quarter hands. The amount of labor performed was as follows:

"The aggregate result makes (adding the negro patches to the cornfields of the plantations) 8,314.13 acres of provisions (corn, potatoes, &c.) planted, 5,489.11 acres of cotton planted—in all, 13,795.23 acres of provisions and cotton planted. Adding to these the 2,894 acres of late corn, to a great extent for fodder, cowpens, &c., to be planted, and the crop of this year presents a total of 16,189.2 acres. The crops are growing, and are in good condition."

"The sum of \$5,479 has been distributed among 4,080 negroes in payment for labor on the plantations. The rate is \$1 per acre for cotton."

After the novelty had passed away very little was accomplished by the slaves. A report in September, makes the effective hands 8,817, non-effective 8,110; acres of corn, 6,444, potatoes, 1,407, cotton, 3,884—which was considered more than enough for their own support, but not sufficient to reimburse the Government. The whole experiment finally failed, and was abandoned by order of Gen. Hunter, and the negroes fell upon the Government for support.

The following order, issued by the Commanding General, would indicate that the moral state

of the negroes had also become deplorable. The General is entitled to much credit for his motives, although the attempt to reform the inveterate conjugal habits of the negro, by a military order, may prove a task beyond his power.

HEADQUARTERS, BEAUFORT, S. C.,  
August, 22, 1862. }

I. In the hope of correcting a wide-spread and deplorable evil, the following regulations are announced:

1st. Any negro claiming to have or charged with having more than one wife, is required to confine himself to, and, if need be, support that one to whom he has been lawfully married. If no such marriage has ever been celebrated, he will select that one of his so-called wives who is the mother of his children, if any he have; and, after a marriage service duly performed by some minister of the Gospel, take her to himself as his own sole lawful wife.

2d. Hereafter any of the colored people wishing to be united in holy wedlock will apply to Rev. M. French, chaplain U. S. Army, or other minister, who will keep a register of marriages and furnish the parties with a marriage certificate duly authenticated.

3d. All negroes, male or female, hereafter living in a state of concubinage, or found unfaithful to their marriage vows, will be liable to arrest and imprisonment.

II. There being on every plantation more or less persons unable to support themselves, and having no near relative to whom the duty can be assigned of providing for their wants, a charitable fund will be established on each plantation, by deducting from the amount due for labor thereon such percentage as may be found, upon trial, sufficient for the purpose.

The fund thus created will be placed in the hands of the superintendent, to be expended by him for the benefit of the helpless and friendless, in providing them with suitable food and clothing, either according to the directions of the surgeon in attendance, or in obedience to the suggestions of his own common sense and experience. A proper account of the expenditures under this head will be furnished monthly to the assistant quartermaster at these headquarters.

III. This order will be read by the superintendents to the negroes on every plantation, and care taken to explain its provisions so that they may be fully understood as designed to secure and regulate the performance of duties which are enjoined by the plainest dictates of a mere worldly experience as well as by the sublimer teachings of a living Christianity.

By order of Brig.-Gen. SEXTON, Commanding.

The efforts in North Carolina were equally unsuccessful.

The negroes near Fortress Monroe, made a better use of their advantages. The military commission to examine into their condition, stated that by the report of the provost marshal at Camp Hamilton, it appears that for the five months ending 1st January, 1862, he had drawn rations amounting to about 383 per day, which were issued to about 650 women and children, and old infirm men, all of whom returned little or no equivalent to the Government. But since the 1st of January, the rations issued there have not exceeded seventy, and for part of the time were less than forty per day. As a consequence the negroes have been thrown very much upon their own exertions to provide for themselves; and the commission of inquiry do not find that any amount of suffering has ensued; but in many instances the effort at self-support has been successful and improving.

Schools have been in successful operation at Camp Hamilton under the charge of clergymen, assisted by other teachers, black and white, where children and adults were daily instructed in reading, writing, and the elements of arithmetic; also religious instruction, and meetings were regularly held on Sunday and stated evenings during the week.

Another measure undertaken, in order to put the negroes to a useful purpose, was to organize the ablebodied ones into regiments of soldiers. The most conspicuous friends of the negroes, who have long urged the measure, have doubtless hoped that so much military spirit might thereby be infused into a considerable number as to qualify them to strike for the emancipation of their race.

On the 9th of June resolutions of inquiry relative to the organization of a negro regiment in South Carolina were offered in the House of Representatives in Congress, and adopted soon after. The resolution was referred to Gen. Hunter by the secretary, who replied as follows:

HEADQUARTERS, DEPARTMENT OF THE SOUTH,  
POST ROYAL (S. C.), June 23, 1862. }

Hon. Edwin M. Stanton, Secretary of War, Washington:

SIR: I have the honor to acknowledge the receipt of a communication from the adjutant general of the army, dated June 13, 1862, requesting me to furnish you with the information necessary to answer certain resolutions introduced in the House of Representatives, June 9, 1862, on motion of the Hon. Mr. Wickliffe, of Kentucky, their substance being to inquire—

1st. Whether I had organized or was organizing a regiment of "fugitive slaves" in this department?

2d. Whether any authority had been given to me from the War Department for such organization? and

3d. Whether I had been furnished by order of the War Department with clothing, uniforms, arms, equipments, &c., for such a force?

To the first question, therefore, I reply that no regiment of "fugitive slaves" has been or is being organized in this department. There is, however, a fine regiment of persons whose late masters are "fugitive rebels"—men who everywhere fly before the appearance of the national flag, leaving their servants behind them to shift as best they can for themselves. So far indeed are the loyal persons composing this regiment from seeking to avoid the presence of their late owners, that they are now, one and all, working with remarkable industry to place themselves in a position to go in full and effective pursuit of their fugacious and traitorous proprietors.

To the second question I have the honor to answer that the instructions given to Brig.-Gen. T. W. Sherman, by the Hon. Simon Cameron, late Secretary of War, and turned over to me by succession for my guidance, do distinctly authorize me to employ all loyal persons offering their services in defence of the Union and for the suppression of this rebellion, in any manner I might see fit, or that the circumstances might call for. There is no restriction as to the character or color of the persons to be employed, or the nature of the employment, whether civil or military, in which their services should be used. I conclude, therefore, that I have been authorized to enlist "fugitive slaves" as soldiers, could any such be found in this department. No such characters, however, have yet appeared within view of our most advanced pickets; the loyal slaves everywhere remaining on their plantations to welcome us, aid us, and supply us with food, labor, and information. It is the masters who have in every instance been the "fugitives," running away from loyal slaves as well as loyal soldiers, and whom we have only par-

tially been able to see—chiefly their heads over ram-parts, or, rifle in hand, dodging behind trees—in the extreme distance. In the absence of any "fugitive master law," the deserted slaves would be wholly without remedy, had not the crime of treason given them the right to pursue, capture, and bring back those persons of whose protection they have been thus suddenly bereft.

To the third interrogatory it is my painful duty to reply that I never have received any specific authority for issues of clothing, uniforms, arms, equipments, and so forth to the troops in question—my general instructions from Mr. Cameron to employ them in any manner I might find necessary, and the military exigencies of the department and the country being my only, but, in my judgment, sufficient justification. Neither have I had any specific authority for supplying these persons with shovels, spades, and pickaxes when employing them as laborers, nor with boats and oars when using them as lightermen; but these are not points included in Mr. Wickliffe's resolutions. To me it seemed that liberty to employ men in any particular capacity implied with it liberty also to supply them with the necessary tools; and acting upon this faith I have clothed, equipped, and armed the only loyal regiment yet raised in South Carolina.

I must say, in vindication of my own conduct, that had it not been for the many other diversified and imperative claims on my time a much more satisfactory result might have been hoped for; and that in place of only one, as at present, at least five or six well-drilled, brave, and thoroughly acclimated regiments should by this time have been added to the loyal forces of the Union.

The experiment of arming the blacks, so far as I have made it, has been a complete and even marvellous success. They are sober, docile, attentive, and enthusiastic, displaying great natural capacities for acquiring the duties of the soldier. They are eager beyond all things to take the field and be led into action; and it is the unanimous opinion of the officers who have had charge of them, that in the peculiarities of this climate and country they will prove invaluable auxiliaries, fully equal to the similar regiments so long and successfully used by the British authorities in the West India Islands.

In conclusion, I would say it is my hope—there appearing no possibility of other reinforcements owing to the exigencies of the campaign in the Peninsula—to have organized by the end of next fall, and to be able to present to the Government, from forty-eight to fifty thousand of these hardy and devoted soldiers.

Trusting that this letter may form part of your answer to Mr. Wickliffe's resolutions, I have the honor to be, most respectfully, your very obedient servant,

D. HUNTER,

Major-General Commanding.

On the 18th of October Gen. Saxton, in command of the Department, issued an order to organize the First Regiment of South Carolina Volunteers as soon as possible. The enlisting of the negroes had proceeded very slowly. Thirteen dollars a month, with army rations and clothing, was to be the pay of the soldier. By the close of the year the regiment was completed.

The attempt was made in Kansas by Gen. Lane to enlist negroes, but it failed of success. His order for their enlistment was as follows:

RECRUITING COMMISSION, DEPARTMENT OF KANSAS, }  
LEAVENWORTH CITY, August 6, 1862. }

*General Orders—No. 8.—1.* That persons of African descent who may desire to enter the service of the United States in this Department, shall fully understand the terms and conditions upon which they will be received into such service, recruiting officers who are authorized, under instructions from this office, to

receive such persons, shall, before receiving them, read to them and in their presence, the following sections of an act entitled "An act to amend the act calling for the militia to execute the laws of the Union, suppress and repel invasion," approved February 23, 1795, and the acts amendatory thereof and for other purposes, approved July 17, 1862, as follows:

Section 12. And be it further enacted, That the President be, and he is hereby authorized to receive into the service of the United States, for the purpose of constructing intrenchments or camp service, or any other labor, or any military or naval service for which they may be found competent, persons of African descent, and such persons shall be enrolled and organized under such regulations, not inconsistent with the constitution and laws, as the President may prescribe.

Section 13. And be it further enacted, That when any man or boy of African descent, who, by the laws of any State, shall owe service or labor to any person who, during the present rebellion, has levied war or has borne arms against the United States, or adhered to their enemies by giving them aid and comfort, shall render any such service as is provided for in this act, he, his mother, and his wife and children, shall forever thereafter be free, any law, usage or custom whatsoever to the contrary notwithstanding. Provided, That the mother, wife, and children of such man or boy of African descent shall not be made free by the operation of this act, except where such mother, wife, or children owe service or labor to some person who, during the present rebellion, has borne arms against the United States, or adhered to their enemies by giving them aid and comfort.

By order of

JAS. H. LANE,  
Commissioner of Recruiting.

T. J. WEED, Major and A. A. G.

An attempt was made by Gen. Sprague, of Rhode Island, to raise a regiment of free negroes, but it met with no success. An attempt was also made at New Orleans to organize negro troops, but at the close of the year it was still an experiment.

Another measure proposed relative to the slaves was their colonization in Chiriqui in Central America. For this purpose Senator Pomroy, of Kansas, who had been very successful in organizing "Emigrant Aid Expeditions" from Massachusetts at the time of the Kansas disturbances, received a kind of general permission from the President to settle at any suitable point within the tropics, being charged "to maintain the honor of the republic abroad." Some progress was made in organizing this enterprise, but it was abandoned.

Another measure proposed relative to the slaves was the removal of a portion of those at Fortress Monroe to Massachusetts and other Northern States, both for "humane and military reasons." (See MASSACHUSETTS.)

Notwithstanding all the measures proposed, the Southern slaves still remain a great burden on the hands of the Government, excepting those who have pressed forward to the free States, already well supplied with white labor.

SMITH, CHARLES FERGUSON, a major-general of volunteers in the United States service, born in Pennsylvania about 1806, died at Savannah, Tennessee, April 25, 1862. He was a son of the late Dr. Samuel B. Smith, U. S. A., graduated with honor at West Point in 1825, and was made second lieutenant of artillery on the 1st of July in the same year. In 1829 he was

appointed assistant instructor in infantry tactics at West Point; in 1831 was promoted to the adjutancy, and in 1832 was made a first lieutenant. In 1838 he was appointed instructor in infantry tactics and commandant of cadets, and the same year was promoted to a captaincy. He took an important part in most of the battles during the Mexican war; in 1847 was brevetted major for gallant conduct in the battles of Palo Alto and Resaca de la Palma, in Texas, and at the battles of Monterey, Contreras, and Ohrubusco, won the successive brevets of lieutenant-colonel and colonel. In the same year he was appointed acting inspector-general in Mexico. On the 25th of November, 1854, he was made major of the 1st artillery, and the following year lieutenant-colonel of the 10th infantry. In Sept. 1861, he was promoted to the colonelcy of the 3d infantry, having the previous month been appointed brigadier-general of volunteers and taken charge of the troops at Paducah, Ky. At the attack on Fort Donelson, the most brilliant charge was made by the troops under his command and had much to do with the surrender. For his gallantry on that memorable occasion he was promoted to a major-generalship, and ordered to take possession of Savannah, Tenn., where he died of chronic dysentery contracted during the Mexican war, and fatally aggravated by his exposures in the campaign of the West.

SOUTH CAROLINA, the first of the Southern States to pass an ordinance of secession from the Union, increased in population 35,201 in the ten years ending June, 1860, when her entire population was 703,708. (*See UNITED STATES.*)

On the last week in December, 1861, the State Convention assembled at Columbia. Its term of existence would have expired some time previous, but by its own act it extended the term. This was done in consequence of the invasion of the State at Port Royal, and the exigencies which arose. Apprehensions were entertained of the ability and competency of the State Government to cope successfully with the unusual affairs, and for this reason the final adjournment was postponed. Its sessions were conducted with closed doors, and none of its acts were made public. An advisory council was instituted, to whom, in conjunction with the governor, extraordinary powers were granted.

The sessions of the Legislature are convened on the second Monday in October. At the last session in 1861 an act was passed authorizing a draft to be made in the districts near the sea coast to make up a strong military force for twelve months to be engaged in the coast defence. Two thirds of all the men capable of bearing arms were to be placed in the field. At the beginning of 1862 these forces were obtained and brought into the field without a draft. At the same time, all persons who had removed their slaves from the seaboard to the interior were required to place them under the

control of white masters. The command of the sea coast defences was vested in General R. E. Lee, who was assisted by Brigadier-Generals Ripley, Lawton, Drayton, and Trapier of the Confederate army, Generals Capers, Harrison, and Walker of Georgia, and Gonzales, De Saussure, and others of South Carolina. The department embraced South Carolina, Georgia, and Eastern Florida. The force in command was regarded as sufficient to repel any invasion of the Federal troops into the interior. The citizens of Charleston had joined the army to such an extent that business was nearly suspended. Seven distinct regiments had at this time taken the field from the city, besides numerous companies and individuals who had entered the army. The cotton on the coast that was exposed to seizure by Federal troops was either entirely removed or destroyed.

In some instances the troops raised for the defence of the State refused to go beyond her borders. This was particularly the case with the 18th regiment of volunteers, which being ordered to the West, after reaching the Georgia railroad, flatly refused to obey the orders of their officers. They alleged that they were enlisted to serve the State, and were willing to fight in her defence, but that they would not go out of the State. Some declared that they would have gone if they had been consulted before starting, but that their officers had not notified them that they were to leave the State; others had furloughs, and desired to see their families. The officers urged in vain the stigma that would rest upon them for refusing to go where their country most needed their services, and the reproach they would bring upon the State of South Carolina, which had been foremost in the work of resistance. Their appeals were unavailing, and the malcontents returned. On the first of May South Carolina had in the field 89,274 men, of whom 22,000 were in the Confederate service. The excess above her quota was 4,064. The State quota at this time was about one fourth of her free white male population.

A very large amount of land in the State was planted in corn, and it was supposed that an enormous crop capable of supplying that species of food in superabundance and at a low price would be the result. But the season was marred by a drought, and in many parts of the State the corn crop was seriously injured, so that there was scarcely more than was produced in the previous year, when much less land was planted. The production of rice also was curtailed to a considerable extent by the removal of the planters from the tide water region. Still the season for rice was good, and those who planted generally made good crops. Apprehensions were entertained that sufficient efforts would not be made to secure the crop.

In October the Legislature convened in Columbia, and the message of Governor F. Pickens was delivered. He urged the support

of the Confederate authorities in measures of the common defence. He withheld all objections to the conscript law, though he regarded all such acts as against the spirit of the Constitution; and recommended that a State guard of citizens under eighteen and over forty-five years of age be formed to counteract the effects of President Lincoln's emancipation proclamation. The State had at that date furnished forty-two thousand troops to the Confederate army, besides eight regiments for coast defence.

At this time General Beauregard was ordered to the command of the Confederate forces at Charleston, and immense fortifications were commenced for the defence of that city against the anticipated attack of the Federal forces.

The attempt to blockade the harbor by the sinking of hulks proved a failure. Numerous passages in the water-front of six miles which the harbor had were left unobstructed, and more vessels ran the blockade and reached the city than at any other Southern port. The force of the west winds, the heave of the sea, and the action of the quicksands soon began to dissipate the obstructions.

STEVENS, ISAAC INGALLS, a major-general of volunteers in the United States service, born in Andover, Mass., in 1817, killed in the battle near Chantilly, Fairfax co., Va., Sept. 1, 1862. He graduated at West Point in 1839, ranking first in his class, and was commissioned second lieutenant of engineers. In 1840 he became first lieutenant, and was employed upon the fortifications of the New England coast until the Mexican war, at that time being adjutant of engineers. He was attached to Gen. Scott's staff, and for gallant and meritorious conduct at the battles of Contreras and Churubusco was brevetted captain, and major for his heroic conduct at the storming of Chapultepec, and the city of Mexico, where he received a severe wound from which he never fully recovered. His profound knowledge of the principles of war, attracted the attention of his general, who spoke of him as "the most promising officer of his age." Upon his return to the United States he was selected by Prof. Bache to perform the duties of chief of the Coast Survey at Washington. In 1853 he resigned his commission and accepted the appointment of Governor of Washington Territory, where he became known as an able executive officer, displaying the most unremitting devotion to the interests of the Territory. During the administration of Pres. Buchanan, he represented Washington Territory as delegate in Congress for two terms. He was the chairman of the Breckinridge executive committee in the presidential campaign of 1860; but when the leaders of the party declared for secession he openly denounced them and stood by the Union, strongly urging President Buchanan to remove Secretaries Floyd and Thompson from the cabinet, and trust to the

counsels of Gen. Scott. At the close of the session of Congress Gov. Stevens proceeded to Washington Territory, but upon hearing of the attack on Fort Sumter, returned to Washington and offered his services to the Government. He was appointed colonel of the 79th New York Highlanders. He was commissioned brigadier-general of volunteers, Sept. 28, 1861, and accompanied Gen. Sherman to South Carolina, where he bore a prominent part in all the battles near Port Royal. He was then transferred to North Carolina, whence he came to Virginia in the corps of Gen. Reno, and was promoted to the rank of major-general, his commission bearing date July 4, 1862. He was in all the skirmishes along the Rappahannock under Gen. Pope, and fought most gallantly in the battle near Bull Run. As he was bearing aloft the colors of one of his regiments, cheering on his men, he fell fatally wounded by a Minie ball passing through his head. In 1851 he published a work entitled "Campaigns of the Rio Grande and Mexico, with Remarks on the recent Work of Major Ripley."

SUMNER, JOHN BRID, D. D., Archbishop of Canterbury, Primate of all England and Metropolitan, born in 1780 at Kenilworth, Warwickshire, died at Lambeth palace Sept. 6, 1862. He was the eldest son of Rev. Robert Sumner, Vicar of Kenilworth, Stoneleigh, was educated at Eton and at King's College, Cambridge, where he graduated B. A. in 1808, obtaining university honors as Browne's Medallist and Hulse's Prizeman. Having been successively Assistant Master and Fellow of Eton College, he became Rector of Mapledurham, Oxon, and was appointed a Canon of Durham in 1820. In 1828 he was consecrated Bishop of Chester, and during the 20 years he held that see, he gave a remarkable impulse to the building of churches and the promotion of education, especially primary education. In 1848 he was translated to the archbishopric of Canterbury, having an annual income of £15,000, and the patronage of the archdeaconries of Canterbury and Maidstone, of two canonries, six preacher-ships in Canterbury Cathedral, and 168 benefices. Dr. Sumner was a prolific theological writer. His first work, "Apostolic Preaching," was published in 1815, and was followed soon after by the "Records of Creation," which obtained the 2d Burnett prize of £400. He was also the author of "Chester Charges," "Evidences of Christianity," "Expository Lectures" on the whole of the New Testament except the Apocalypse, in nine separate volumes, and several volumes of sermons. He belonged to what is termed the Evangelical School in the established Church, and his term of office will be memorable in the Church history of England by the revival of the synodical power of the two Convocations of England, and the violent controversy arising out of the publication of the work entitled "Essays and Reviews."

## T

**TAE-PING REBELLION, THE.** As the principal interest in Chinese matters centres in this rebellion, it will, perhaps, be more gratifying to the readers of the Annual Cyclopædia, to have a clear and connected account of this protracted and extensive insurrection than to read a mere summary of the prominent events which have transpired in China during the year 1862.

The Government of China, though seemingly so immobile, has yet passed through numerous changes. Its vast area has been at some periods divided into two, three, and even four independent kingdoms, and after years of civil war again and again reunited in a single empire; its rulers have been native Chinese, Mongol Tartars, Chinese again, and lastly, since 1644, Mantchoo Tartars. In the 4,000 years of its history, there have been few periods when, either from Tartar invasion, or native insurrection, from religious feuds, or conflicts of race, there has not been, in one or other of its populous provinces, a rebellion of some sort. At the present time, under the feeble and corrupt rule of the late Mantchoo emperor, there have been and are now in existence four distinct insurrections; the Tae-ping rebellion, occupying a territory of over 80,000 square miles on the lower Yang-Tsze; the Tu-feh rebellion, in the vast western province of Sz'chuan, on the upper Yang-Tsze and its affluents; the Chinese Mussulman insurrection, in the S. W. province of Yu-nan, and a formidable and powerful band of insurgents in the north-eastern province of Shan-Tung.

All of these have native Chinese leaders, and all are alike hostile to the Mantchoo dynasty; but beyond this they have little in common, except that cowardly cruelty, which delights in profuse slaughter, under circumstances of terrible atrocity, of all their captives. The last three of these insurrections, though, perhaps, counting nearly as many followers as the first, have not for a variety of reasons excited so much attention or remark abroad as the Tae-ping rebellion.

Hung-Siu-Tsuen, the leader of the Tae-ping rebellion, or as he styles himself the *Tien-Wang* (king of Heaven), is a native of an insignificant village, 80 miles from Canton, and was born in 1818. His parents were very poor, so poor that they were unable to give him sufficient education to compete successfully at the state examinations, which every one who seeks to become an officer of Government in China must pass. From his 19th year, he repaired annually for half a dozen years to Canton to these examinations, but each time failed of success. At one of these visits, in 1838, an American missionary, Rev. I. J. Roberts, gave him a package of tracts in Chinese, which he put in his pocket and for the time thought no more of them.

Four years after, again meeting with his accustomed ill fortune, he returned home, was attacked with a violent sickness, during which he saw visions, and uttered inflated rhapsodies in regard to his future; on his recovery he engaged in menial occupations for his support, and once more passed an unsuccessful examination. On his return home the tracts he had received five years before, fell under his notice, and he read them with avidity. He declared that they gave him the key to the visions he had had in his sickness, and abandoning the religion of Confucius, he left his native place, and, betaking himself to the mountains, set about making converts to his new religion. His views were very crude; he at first worshipped the name of God instead of the idols, to which he had formerly burned incense and gold paper, but after a few months, becoming more enlightened, he abandoned this and adopted some forms nearer to those of Christian worship, though modified to suit the sensuous ideas of the Chinese. In 1840 he had made a considerable number of converts, who were called God-worshippers, and not long after, there were nearly 2,000 of his adherents in the single district of Kevei. He now sallied forth with his followers to destroy the idolatrous temples of the Buddhists and Lao-tze. This provoked disturbance, and two of his disciples were thrown into prison, where one of them died. Alarmed, perhaps, at this result of his iconoclastic mission, Hung-Siu-Tsuen (or as he now called himself Sin-Tsuen, *i. e.* elegant and perfect) abandoned his public teachings, and lived a quiet life as a cattle herd for some years. He seems still, however, to have kept up his connection with the God-worshippers, and to have been regarded as their leader. Up to this time, his views and teachings seem to have been those of an ill-instructed but sincere convert to Christianity, but a change for the worse took place in 1850. A rebellion had sprung up in the districts of Kwang-si and Kwang-rung, in the province of Canton, resulting primarily from the restless and wretched condition of the people, who had been visited by famine and pestilence during that year. Bands of robbers infested the country, and being hard pressed by the imperial soldiers, joined the God-worshippers, to enlist their influence in protecting them. The authorities sought to arrest Sin-Tsuen as their leader, but he, calling all his followers together, seized and fortified a market town, and thus in December, 1850, commenced the Tae-ping (peace) rebellion. He selected from among the most intelligent and bold of his followers, leaders for the numerous adherents who now began to flock to his standard, and gave them the title of *Wang* (king). In four months' time he had, accord-

ing to Chinese ideas, a powerful and well-disciplined army, strongly attached to him personally, and ready to fight to the death for their creed. The rebel chief now commenced issuing proclamations, in which the influence of flattery in producing arrogance and intolerable conceit were very evident. He assumed the title of Tien-Wang (king of Heaven), and soon began to claim divine honors; at first he declared himself the brother and equal of Christ, and required the same homage, but of late he has grouped in his manifestoes God the Father, Jesus Christ, himself, and his son, whom he styles the junior Lord, as the co-equal rulers of the Universe; and at one time he conferred the title of the third person of the Trinity upon Tung-Wang, the most blood-thirsty of his subordinate kings, but subsequently withdrew it, and now admits no other divine personages but those we have mentioned. He professes to have often visited heaven, and of late declares that his favorite wife (he has 108 in his harem) has also been permitted to ascend to the celestial regions. His proclamations, whatever may be their principal topic, are always interlarded with theological disquisitions, and as he has read extensively theological and religious books, they often present a singular medley of truth and error, presented in a most arrogant and grandiloquent style.

But with all his religious vagaries, he showed a considerable amount of administrative ability. In August, 1851, he captured the city of Yung-an, and held it until April 7, 1852, when, at the head of a large force, he traversed and ravaged the province of Hoo-nan, destroying many of its finest cities; he next descended the Yang-tze river, visited Hankow and other cities on its banks, and early in 1853 sat down before the great city of Nanking, which surrendered to him on the 19th of March, 1853, after a feeble resistance, and whose inhabitants to the number of more than 20,000 he put to death. One hundred only of those who fell into his hands were saved. This ferocity he justified by some of the examples of the Old Testament. The people, he said, were idolaters, whom it was his right, as king of Heaven, to destroy.

Nanking, thus captured, was made his capital, and instead of moving forward, as he could have done, upon Peking, he retired into complete seclusion, forbidding the admission even of most of his officers to his presence, and spending his whole time in his harem, in theological studies, and in the composition of prayers and proclamations. The imperial forces soon commenced the siege of the city, but did not for several years close the river, and the Tae-pings were not distressed; finally a fleet of junks blockaded the river, and starvation began to threaten the Tien-Wang and his followers. In the emergency he composed a doxology, which all the officers and soldiers were required to commit to memory, the purport of

which was that the power of God would be exerted for their relief, day after day as the rations grew more scanty, this doxology was shouted by the Tae-ping army, till at last two of the kings, who were at some distance, attacked the imperial force from the rear, while the besieged made a sortie which broke up the siege. Shanghae was subsequently attacked by the Tae-pings, but the English naval force defended it, and made terrible havoc among the rebel troops with their artillery.

During the war between the allied forces (England and France) and the Chinese emperor, which terminated in the treaty of Tien-tsin in Oct. 1860, the Tae-pings contented themselves with plundering the region about Nankin; and attempted no great enterprises; but since that time they have been more active, and on the 9th Dec. 1861, captured the city of Ningpo, one of the free ports, at which the Western powers traded. They respected the lives and property of the foreign residents, but butchered without mercy the native inhabitants. They next announced their determination to attack Shanghae; but the allied forces notified them that that city was under their protection. The Tae-pings paid no attention to this notice, but approached the city, and prepared to assault it. Thus defied, the allied forces attacked them in April, 1862, and between the 17th of that month, and the 19th of May, had captured six large cities, and among them Ningpo, which were occupied by the rebels. These successes were not obtained without considerable losses both from the fire of the Tae-pings and the climate, and though they were able to protect Shanghae from invasion, they could not act further on the offensive. The imperial Government, meantime, had signified its willingness to undertake the putting down of the rebellion if it could be supplied with ships of war and artillery, which the European powers have agreed to furnish.

The changes which have taken place in the imperial Government of China since August, 1861, give some reason to hope that the period of misrule there is past, and that a wiser policy is to be pursued in the future. The emperor, Hien-fung, on the approach of the allied forces to Peking in 1860, had gone to his country palace of Jehoh or Jehol, in Chinese Tartary, where he remained, refusing to return after the treaty of peace had been concluded between the allies and his brother, Prince Kung. At this palace he died on the 22d August, 1861, at the age of 80, after a reign of a little more than ten years. He was the fourth son of Tao-Kouang, whom he succeeded, but had been chosen by his father as his successor, in the belief that he possessed high capacities for the ruler of a great nation. He was but 19 years of age when he ascended the throne, and he was surrounded by artful courtiers, who soon persuaded him to give himself up to the pleasures of the harem, and leave to

them the labor of governing. Under the management of these councillors, the people were outrageously plundered and robbed, and all real knowledge of their condition was kept from him. At his death, his son Tsai-Chun, 7 years old, was proclaimed emperor under the regency of these same corrupt councillors and the empress mother, and remained at Jehoh. The prince Kung, who had shown himself a man of more ability, integrity, and enlightened views than any other of the imperial family, and through whom the treaty with the allied forces had been concluded and ratified, was left out of the regency. As the nearest relative, except the empress, of the young emperor, he was not disposed to submit to this exclusion. He accordingly visited Jehoh, and in October returned to Peking with the young emperor and his mother, proclaimed a joint regency of the empress mother and himself, the late emperor having, as he declared, made no appointment of regents; caused the late councillors to be arrested, and summoned a high court of members of the imperial family to try them. The three who had usurped the regency were condemned to death, and the others were degraded and exiled. The prince Kung has since turned his attention to the reformation of the Chinese Government, to a more vigorous and honest administration of the laws, and the putting down of the various rebellions in progress. He has carefully and faithfully observed the treaties made with the allies, and has requested them to procure for him, at the expense of the Government, ships of war, artillery, and ammunition, to enable him to suppress the insurrections. He has opened a considerable number of the interior ports to foreign trade, and seems determined to encourage commercial and social progress. Foreign missionaries are to be allowed to instruct the people in Christianity without hindrance. There is, however, much to be done to make the Chinese a really civilized nation.

TENNESSEE, the first Confederate State occupied by the Federal armies, and one of the most populous of the Southern States, increased in population 107,084 during the ten years ending in June, 1860. The full details given by the census returns thus far made up, relative to the State, will be found under UNITED STATES, to which the reader is referred.

Nothing of special importance occurred in the State at the commencement of the year 1862, while under Confederate control, previous to the advance of the Federal army under Gen. Grant—for which see ARMY OPERATIONS, and also NASHVILLE.

The great Federal victories at Forts Henry and Donelson, and the consequent evacuation of Bowling Green, rendered Nashville no longer tenable.

The Legislature and executive officers of Tennessee had made preparations for such a contingency, and lost no time in removing to Memphis, where, on the 20th of February, Gover-

nor Harris addressed a message to the senate and house of representatives, in which he said:

I deemed it my duty to remove the records of the Government to and convene the Legislature at this city, for the following reasons: The disaster to our arms at Fishing Creek [Mill Spring or Webb's Crossroads] had turned the right flank of our army, and left the country from Cumberland Gap to Nashville exposed to the advance of the Union army. The fall of Fort Henry had given the enemy the free navigation of the Tennessee river, through which channel he had reached the southern boundary of Tennessee, and the fall of Fort Donelson left the Cumberland river open to his gunboats and transports, enabling him to penetrate the heart of the State, and reach its capital at any time within a few hours, when he should see proper to move upon it.

The message, after enumerating the measures previously taken by the executive in support of the Confederate cause, and reminding the Legislature that at the time of the capture of Fort Donelson there was not a single organized and armed company in the State subject to the governor's command, recommended the amendment of the militia system, the organization of a part of the militia as cavalry and artillery, and the passing of a bill to authorize the raising, arming, and equipping of a provisional army of volunteers, and to appropriate ample means for this purpose. Governor Harris immediately took the field in person, having on the previous day issued a proclamation calling upon the people to arm themselves, and a general order to the militia, appointing places of rendezvous, and designating their commanders. On the 22d, Gen. U. S. Grant issued the following order from Fort Donelson:

Tennessee, by her rebellion, having ignored all laws of the United States, no courts will be allowed to act under State authority, but all cases coming within the reach of the military arm, will be adjudicated by the authorities the Government has established within the State.

Martial law is therefore declared to extend over West Tennessee. Whenever a sufficient number of citizens return to their allegiance to maintain law and order over the territory, the military restriction here indicated will be removed.

On the next day (the 23d), the Confederate troops evacuated Nashville; and on the 25th the city was occupied by the advance of the Federal army under Gen. Nelson. A large portion of the State having now been reconquered to the Union, President Lincoln nominated Andrew Johnson Military Governor of Tennessee, with the rank of brigadier-general of volunteers, and the nomination was confirmed by the Senate on the 5th of March. Governor Johnson, a native of North Carolina, had been 5 times a representative in Congress, and twice Governor of Tennessee, and at the time of his appointment was U. S. Senator from that State. He reached Nashville March 12th, in company with Emerson Etheridge, Clerk of the House of Representatives, and Horace Maynard, Member of Congress from Tennessee, and the next evening, in response to a serenade, he made an address, which he afterward published as an "Appeal to the People of Tennessee." After briefly recounting the



history of the secession movement, and the measures adopted by the Federal Government, he proceeded as follows:

The President has conducted this mighty contest, until, as commander-in-chief of the army, he has caused the national flag again to float undisputed over the Capitol of our State. Meanwhile, the State Government has disappeared. The executive has abdicated; the Legislature has dissolved: the judiciary is in abeyance. The great ship of state, freighted with its precious cargo of human interests and human hopes, its sails all set, and its glorious old flag unfurled, has been suddenly abandoned by its officers and mutinous crew, and left to float at the mercy of the winds, and to be plundered by every rover upon the deep. Indeed, the work of plunder has already commenced. The archives have been desecrated, the public property stolen and destroyed; the vaults of the State Bank violated, and its treasures robbed, including the funds carefully gathered and consecrated for all time to the instruction of our children.

In such a lamentable crisis, the Government of the United States could not be unmindful of its high constitutional obligation to guarantee to every State in this Union a republican form of government, an obligation which every State has a direct and immediate interest in having observed toward every other State; and from which, by no action on the part of the people in any State, can the Federal Government be absolved. A republican form of government, in consonance with the Constitution of the United States, is one of the fundamental conditions of our political existence, by which every part of the country is alike bound, and from which no part can escape. This obligation the national Government is now attempting to discharge. I have been appointed, in the absence of the regular and established State authorities, as Military Governor for the time being, to preserve the public property of the State, to give the protection of law actively enforced to her citizens, and, as speedily as may be, to restore her Government to the same condition as before the existing rebellion.

In this grateful but arduous undertaking, I shall avail myself of all the aid that may be afforded by my fellow citizens. And for this purpose I respectfully but earnestly invite all the people of Tennessee, desirous or willing to see a restoration of her ancient Government, without distinction of party affiliations or past political opinions or action, to unite with me, by counsel and coöperative agency, to accomplish this great end. I find most, if not all of the offices, both State and Federal, vacated either by actual abandonment, or by the action of the incumbents in attempting to subordinate their functions to a power in hostility to the fundamental law of the State, and subversive of her national allegiance. These offices must be filled temporarily, until the State shall be restored so far to its accustomed quiet, that the people can peaceably assemble at the ballot box and select agents of their own choice. Otherwise anarchy would prevail, and no man's life or property would be safe from the desperate and unprincipled.

I shall, therefore, as early as practicable, designate for various positions under the State and county Governments, from among my fellow citizens, persons of probity and intelligence, and bearing true allegiance to the Constitution and Government of the United States, who will execute the functions of their respective offices, until their places can be filled by the action of the people. Their authority, when their appointments shall have been made, will be accordingly respected and observed.

To the people themselves, the protection of the Government is extended. All their rights will be duly respected, and their wrongs redressed when made known. Those who through the dark and weary night of the rebellion have maintained their allegiance to the Federal Government will be honored. The erring and misguided will be welcomed on their return. And while it may become necessary, in vindicating the

violated majesty of the law, and in reasserting its imperial sway, to punish intelligent and conscious treason in high places, no merely retaliatory or vindictive policy will be adopted. To those, especially, who in a private, unofficial capacity have assumed an attitude of hostility to the Government, a full and complete amnesty for all past acts and declarations is offered, upon the one condition of their again yielding themselves peaceful citizens to the just supremacy of the law. This I advise them to do for their own good, and for the peace and welfare of our beloved State, endeared to me by the associations of long and active years, and by the enjoyment of her highest honors.

The address was listened to with respect and some favor; but the Union feeling developed in Nashville, and other parts of Middle Tennessee, after their occupation by the Federal forces, was far from answering the expectations of the North, or even of the Tennessee Unionists themselves. On the 9th of March, the citizens of Shelbyville, in Bedford county, burned a quantity of Confederate stores, to prevent them from falling into the hands of the Confederates; and soon afterward the people of Gallatin, a place in which the Southern party had before been strongly in the ascendant, held a town meeting, and expressed a readiness to return to their allegiance; but these were exceptional instances, and the Federal occupation did not become popular until there seemed reason to think it would be permanent.

On the 25th, the governor required the Common Council and other city officials of Nashville, to take the oath of allegiance to the United States, and on their refusal to do so, he issued a proclamation declaring vacant the offices of most of them, and appointing persons to act in their places until a new election could be held by the people. The mayor of Nashville, and some other citizens, were arrested on the 29th, on the charge of "disloyal practices." The newspaper press was placed under military supervision; several papers suspended publication, and on April 10th, the "Daily Nashville Union" was commenced by S. C. Mercer, a refugee from Kentucky. Affairs soon began to wear a more flattering aspect. "For several days," says the "Union" of April 11th, "the office of Governor Johnson in the Capitol has been thronged with secession men and women from the city, and adjacent country, earnestly interceding for their sons who have been, or are now, in the rebel army, and expressing the utmost willingness and even anxiety, to take the oath of allegiance to the good old Government, and faithfully discharge the duties of law-abiding, and loyal citizens." On the 12th, the editor of the "Nashville Banner" was arrested, and placed in confinement, on the charge of uttering treasonable and seditious language; and on the 15th, J. O. Guild, of Gallatin, judge of the Chancery Court, was arrested on charge of treason, by an officer of Governor Johnson's staff, and conveyed to Nashville.

On the 20th the following letter was addressed to the governor by seven Confederate officers confined at Camp Chase, near Columbus, on behalf of themselves and "a great

many others whose names were not subscribed:"

*To Andrew Johnson, Governor, &c., of the State of Tennessee:*

We the undersigned citizens of Columbia, Tenn., having gone into service, under the last call of Gov. Harris, the circumstances of which call, and our enlistment, you have by this time become fully aware of, are very desirous of returning to loyalty by taking the oath of allegiance to the Federal Government, and will ever feel grateful to you for our deliverance from our present confinement.

Several other letters of like import, from Tennesseans who had served in the Southern army, were published about the same time.

Trade, for some time after the occupation of Nashville, gave no sign of reviving. Northern merchants had followed the national armies into Tennessee, in the expectation of buying cotton, and obtaining markets for their own commodities; but there was little or no cotton at Nashville and other river ports, and the planters of the interior showed no disposition to send it forward. Northern products of nearly all sorts were in great demand, and quoted at high prices; but the people had no money except the currency of the Southern Confederacy, which the Northern speculators, of course, refused to take. In a few weeks' time, however, U. S. money became comparatively plentiful throughout Middle Tennessee; confidence in the depreciated bills of Tennessee banks was restored; and cotton gradually found its way to the ports of outlet.

Buyers began to scour the country in all directions, within, and sometimes even beyond the Federal lines. The reluctance of the cotton planters to sell was soon entirely overcome. Good middling brought in April, 16 and 17 cents in specie, or U. S. Treasury notes, and 22 and 25 cents in current Tennessee paper. The following extract from the "Nashville Union" of May 10, shows the state of the Tennessee cotton traffic at that date:

Upon enquiry we have ascertained that down to the 1st of this month permits were granted for the shipment from Nashville of 2,913 bales of cotton. The requirement of permits for the shipment of goods from this to the loyal States having been abrogated, it is not easy to ascertain the precise number of bales of cotton that have been shipped since the 30th ult. Upon enquiry we have ascertained that since that date there have been shipped 634 bales. To this amount may be added from 50 to 100 bales shipped by outsiders, who are unknown to us. The whole amount shipped since the 11th of March, when trade was opened, may be set down as not less, and probably something over, 3,600 bales. The price it now commands readily is 20 cents in gold or U. S. Treasury notes—at times lots are sold at 21 cents, and at others at 19 cents. The entire amount which it may be expected will be shipped from this place during the season is estimated to be about 13,000 bales. From two to three thousand bales have been burned by the Confederate troops—chiefly in Giles county. The cotton already sold at this point has brought into the country \$360,000 of good currency, either in specie or U. S. Treasury notes. If no obstacle shall be placed in the way of trade by the further operations of rebel marauding parties composed of worthless and irresponsible vagabonds, the cotton already shipped and to be shipped at this point will bring \$1,800,000. That burned by

the rebels is estimated at \$800,000, the average value of the bales being \$100 each.

Rice was also shipped to some extent, and the quantity of both these staples sent into the loyal States would have been much greater but for guerilla bands, who made it their object to prevent the crops from being sold. A proclamation was issued by the governor, threatening to imprison five or more secessionists of the neighborhood where such things occurred.

On May 12, in pursuance of a call signed by a number of prominent citizens, requesting "their fellow citizens of the State of Tennessee, who are in favor of the restoration of the former relations of this State to the Federal Union, to be present at a public meeting to be held at the capitol, in the city of Nashville," a large gathering of persons from different parts of the State took place in the Hall of Representatives. Ex-Gov. Wm. B. Campbell (now brigadier-general) was chosen president of the convention, and on taking the chair made a few remarks, in the course of which he said:

We invite all to help us in restoring the supremacy of law over Tennessee, and reinstating her in all the privileges and immunities of the Union. We wish to welcome back all our deluded fellow citizens cordially. The Government intends no sweeping confiscation, nor wild turning loose of slaves, against the revolted States. It designs no infringement on the rights of property. All will be protected who will be loyal to the Government. We bear no malice toward any one, but deep sympathy for the deluded. He had dear friends and dear relations who had gone astray, and his heart yearned for their return. The Federal Government will pursue a kind, liberal, and benevolent policy toward the people of the South, to bring them to the Union.

Addresses were made by W. H. Wiseman, Hon. W. B. Stokes, Edmund Cooper, Col. W. H. Polk, Gov. Johnson, Col. L. D. Campbell, Gen. Dumont, and others.

At the request of many persons present at this convention, the chairman appointed Allen A. Hall, John Lellyett, Russell Houston, Horace H. Harrison, and M. M. Brien, a "State Central Union Committee," for the purpose of communicating with the friends of Union in various parts of the State.

The United States circuit court opened at Nashville on the 13th, and in his charge to the Grand Jury, Judge Catron instructed them to ferret out and indict all persons guilty of aiding and abetting the marauding parties who infested the State.

On the 14th ex-Gov. Neil S. Brown, one of the leaders of the secession party in Tennessee, was arrested, by order of Gov. Johnson, on charge of treason, but was afterward released on parole. He took the oath of allegiance, and became a prominent advocate of the Union.

The following notice was issued at Nashville on May 18:

After this date no shipment of merchandise from this city or State will be allowed, except upon permits therefor issued by the proper constituted officers of the Government of the United States.

On the 21st, D. F. Carter, president, and John Herriford, cashier of the Bank of the Union at Nashville, were arrested on charge of treason, and placed in confinement.

An election for judge of the circuit court of Nashville, held on the 22d, resulted in the choice of Turner S. Foster, secessionist, by a majority of about 190. The Union vote was about 1,000; the vote against separation in Nashville in June, 1861, was only 300.

Judge Foster received his commission from the provisional governor on the 26th of July, and the same day was arrested and sent to the penitentiary.

On the 24th of May a Union meeting was held at Murfreesboro', at which speeches were made by Gov. Johnson and others, and the resolutions of the Nashville Union Convention of the 12th were unanimously adopted. Thirty-four soldiers of a Tennessee regiment in the Southern army came before the provost marshal on that occasion, and took the oath of allegiance.

On the same day, under the provisions of the general confiscation act of August 6, 1861, the United States Marshal for the Middle District of Tennessee seized at Nashville the offices of the "Republican Banner," "Union and American," and "Gazette" newspapers, and the Southern Methodist Publishing House, and on the 26th the Baptist Publishing House, and "Patriot" newspaper office, all having been active supporters of the secession movement. He also seized two gun factories in South Nashville, belonging to stock companies.

The address of the committee appointed by the Nashville Union Convention to draw up a paper setting forth the purposes of that meeting was published, June 4th. After reviewing the prosperity of Tennessee before the civil war broke out, it thus depicts the condition to which the State had been reduced by secession:

We are without representation in the national Legislature, and laws touching our most vital interests are enacted without our participation or consent. War in its most terrible form is at our doors—civil war, the scourge of nations and of the human race; here it is with all its horrors. And look at its effects upon the interests of our people! Our schools, academies, colleges, and universities as places of education and instruction are closed, and are only used as barracks for troops or as hospitals for sick and wounded soldiers. Our common school fund, for the education of the poor and helpless, has been abstracted and carried off by unauthorized and irresponsible persons beyond the control of the legitimate authorities of the State or even their own control. The funds of our State bank, our only financial agent and place of safe-keeping of the money of the State, have been seized and carried within the control of men at war against the Government. Our State debt is increased by millions without a dollar consideration. Our credit is dishonored and our currency ruined. Our commerce is cut off and our manufactures shut up. Our fences are destroyed, bridges burned, private property taken, and crops consumed under the plea of military necessity. Our fields are uncultivated and the hand of industry is still. Our cities, towns and country, are crowded with troops, and our public highways and street corners blockaded with military guards. Our Governor,

Secretary of State, Comptroller, and Treasurer, with the public records of the State, are missing. Our courts are suspended, and we are without a regular government. Our sons and brothers, and our relations and friends are on the eve of battles, probably the most destructive to be recorded in history. And at a time when most needed, our churches are closed, our ministers of religion absent from their duties or in the army, and instead of "Peace on earth; good will to men," it is war to extermination.

The address discusses the abstract right of secession, defends the conduct of the Federal Government, shows the advantages of adhering to the North and the certain misery to follow a union with the Southern Confederacy.

Governor Johnson, about the same time, issued an order providing that all persons who should be arrested for using treasonable and seditious language, and who should refuse thereafter to take the oath of allegiance and give bonds in the sum of \$1,000 for future good behavior, should be sent South beyond the Federal lines, with the distinct understanding that if they returned they were to be treated as spies.

Memphis was captured by the river fleet on the 6th, and West Tennessee was thus brought under the control of the Federal Government. (See MEMPHIS.)

On the 7th a Union meeting was held at Shelbyville, Governor Johnson, Col. May of Kentucky, and James L. Scudder, formerly a prominent secessionist and assistant inspector general of State troops under Governor Harris, being among the orators.

On June 17th Governor Johnson summoned six prominent secession clergymen of Nashville to meet him at the capitol, and requested them to take the oath of allegiance to the Federal Government. At their urgent desire, a few days were granted them for deliberation. On the 28th, as they refused to take the oath, five were sent to the penitentiary, to be kept in close confinement until arrangements could be made for escorting them beyond the lines: the sixth, being in feeble health, was paroled. On the same day Dr. J. P. Ford, and on the next day the Rev. C. D. Elliott, principal of a girls' boarding-school, and Dr. Cheatham, superintendent of the State Lunatic Asylum, were arrested at Nashville and similarly disposed of. At a Union meeting held in Pulaski, June 17, Mr. George Baber, formerly identified with the Southern party as editor of the Nashville "Banner," delivered an address in which he disavowed his past course. Another meeting of the people of Giles county was held at the same place on the 21st, when resolutions were passed whereby the citizens pledged themselves to use their influence for the speedy restoration of the State to her federal relations. Giles county is one of the most flourishing in Middle Tennessee. It is largely engaged in cotton growing, and works over 5,000 negroes. On the 23d five of the most prominent secessionists of Pulaski, including the Rev. Mr. Mooney, a Methodist clergyman, were arrested

and sent beyond the Federal lines under an escort of cavalry.

A Union meeting was held at Valley Springs Meeting House, Dickson county, on the 21st.

The anniversary of American independence was celebrated with great enthusiasm, and Union speeches were delivered at the capital and in other parts of the State.

Arrests continued frequent, and in the early part of July twenty-eight persons were arrested at Goodlettsville, but were all released on taking the oath of allegiance.

In the mean time, the Union citizens of the State had been almost incessantly harassed by roving bands of guerillas and marauders, of whom the cavalry forces of Cols. Forrest and Morgan acquired the greatest notoriety. Scarcely a day passed which did not bring a report of their seizing horses, cattle, and stores, burning bridges, tearing up railroad tracks, destroying telegraphic communications, and not unfrequently killing prominent Union men or falling unexpectedly upon small detachments of Federal troops. On the 1st of May a party of Col. Morgan's horsemen entered Pulaski and destroyed the goods of a shop keeper of that place. A military commission examined the case on the 20th, and ordered the provost marshal to collect from the secession authorities of the town, or failing in that, from certain well-known Confederate citizens, a sum sufficient to cover all the damages. As soon as Memphis had fallen the Confederate cavalry began to infest the line of the Memphis and Charleston railroad, burning cotton, carrying off Union citizens, and threatening to seize the person and destroy the property of any one who attempted to enter Memphis upon whatever pretext. On the 7th of July the pickets of a Minnesota brigade were attacked near Murfreesboro' by a party of civilians, and two of the soldiers were killed. The next day 90 guerillas were captured between Gallatin and Hartsville. On the 9th a wagon master and a sutler were fired upon from an ambush near Franklin, the latter being killed and the former severely wounded. Similar murders were perpetrated near Memphis. On the 18th Colonels Forrest and Warner, with a regiment of Texan Rangers and a strong force of other Confederate troops, captured Murfreesboro'; and on the 21st a party of Forrest's guerillas captured the Federal pickets on the Lebanon road.

The greatest excitement now existed at Nashville, and the loyal citizens proceeded to enroll themselves in anticipation of an attack upon the city, but in a few days reinforcements arrived and the guerillas fell back toward McMinnville. On the 17th an attack was made by about 60 guerillas upon a small scouting party belonging to Gen. Negley's command, between Mount Pleasant and Columbia. The Federal soldiers, only 8 in number, took refuge in a house and defended themselves for 6 hours, the guerillas finally retiring. On the 19th a party of 11 guerillas entered Brownsville and destroyed a

large quantity of cotton. On the 2d of August Gen. Nelson occupied McMinnville, the Confederates falling back before his arrival. Gen. Negley about the same time led an expedition against the guerillas in the direction of Columbia, dispersing a large assemblage of the marauders at Williamsport, and engaging them again with success at Kinderhook. On the 12th a detachment of Col. Morgan's guerillas surprised Gallatin, on the Louisville and Nashville railroad, making 130 prisoners and capturing a quantity of government stores, with a train of grain and 65 horses on the way from Louisville to Nashville. A force was immediately sent from Nashville to intercept them, but arrived only in time to capture a wagon load of arms, and exchange shots with stragglers on the outskirts of the town. On the 16th a party of workmen sent to repair the railroad which had been injured by Morgan near Gallatin were captured by guerillas, and the same day two Federal couriers were made prisoners a few miles south of Nashville. Railroad communication with the latter place was now entirely cut off on every side, bridges being burned and the track torn up for considerable distances, but the interruption lasted only a short time. On the 18th a railroad train was fired into near Columbia, a woman and child and two Federal soldiers being killed. The day afterward Clarksville was captured by a guerilla force, assisted by the disunion inhabitants of the town, Col. Mason of the 71st Ohio and about 800 men surrendering without resistance.

On the 20th a guard of 20 men under Captain Atkinson of the 50th Indiana volunteers, being attacked at Edgfield junction by an overwhelming force of guerillas under Col. Morgan, defended themselves for 3 hours behind a stockade, repulsing their assailants three times, and saving the train to Bowling Green which it seems to have been Morgan's intention to capture.

A second engagement with Morgan at Gallatin on the 22d proved a much more disastrous affair than the raid on the 12th. Gen. R. W. Johnson was taken prisoner, and more than half his command of 800 men were killed or captured. The guerillas emboldened by success now became more than ever troublesome. Travel ceased to be safe even within a few miles of the capital; the mails were robbed; Union citizens were seized and sent to the South, and small detachments of Federal troops were frequently surprised by these daring horsemen, whose rapid movements generally set pursuit at defiance. At McMinnville they attacked the stockade, but the little guard repulsed them with heavy loss; and on the 28th Col. Forrest's band had a severe engagement with a Federal Kentucky regiment near Woodbury, losing 8 killed, 30 wounded, and 15 prisoners. On the 10th of September some Federal officers were captured by guerillas while dining at a house two or three miles

from Nashville. At Covington, Tipton county, in the western part of the State, where such raids had been common, the citizens gave bonds in the sum of \$50,000 to protect Union residents, and declared their purpose of hanging all guerillas who fell into their hands. The interior of the State was not only harassed by organized bands, such as those of Forrest and Morgan, who held regular commissions in the Confederate army, but were also ravaged by marauders of the worst description, who had no object but plunder, and robbed both parties alike. The guerillas also gathered in considerable force in the counties bordering on the Mississippi, and attacked transports and other vessels on the river, generally with musketry alone, but sometimes with light field artillery. On the 29d of September a party of twenty-five or thirty men at Randolph, armed with rifles, muskets, and shot-guns, signalled the steamer Eugene to land. As the boat had two passengers and some freight for that point, she rounded to, none of the officers perceiving the guerilla band, who in fact had kept in the background up to that time. It was now apparent, as the guerillas sprang from their hiding place, that the intention was to seize the boat; and the captain, regardless of the demand to surrender, boldly pushed back into the stream amid several volleys of musketry. There were a great many passengers on board, including women and children, but no one was killed or hurt.

The outrage having been reported the next day to Gen. Sherman, at Memphis, he sent the forty-sixth regiment of Ohio volunteers and a section of Willard's Chicago battery to destroy the town. These troops took passage on the steamers Ohio Belle and Eugene, which arrived at Randolph on the 25th. The inhabitants seemed to have been impressed with the conviction that the town would be destroyed, and consequently most of them had left the place. The quartermaster of the regiment went through the town and took an inventory of the buildings and their probable worth, with their owners' names, as far as they could be learned. This having been done, and everything in each house having been removed, every house in the town was burnt to the ground, except the Methodist church, which was left standing for the accommodation of the few persons turned out of doors by the fire. All the cotton and other property of value as merchandise was brought away.

The town of Randolph, thus destroyed, contained about ninety houses, said to be mostly in a dilapidated condition. It is situated about sixty miles above Memphis, and was the site of extensive Confederate fortifications before the Mississippi river was opened.

To prevent similar occurrences in future, General W. T. Sherman, commanding at Memphis, ordered that for every boat fired upon ten disloyal families should be expelled the city.

On Oct. 21st the President recommended an election for members of Congress to be held in several districts of Tennessee, and instructed the military commanders to take measures to facilitate the execution of the order.

The progress of the campaign had now brought the Confederate forces almost within sight of Nashville, and the guerillas, hovering over the route of the regular forces, carried off stragglers from the Federal columns and rendered important service to their cause by burning bridges, skirmishing with pickets, and threatening the Union supply trains. On the 19th of October, Col. Forrest was defeated on the Gallatin turnpike about 7 miles from Nashville by a Union brigade under Col. Miller. On Nov. 5th Morgan made a dash at a Federal camp north of the Cumberland, but was repulsed with some loss. The same active chieftain on the 9th was driven out of Gallatin by a detachment of Gen. Crittenden's corps, and the next day was beaten at Lebanon, where the Federalists captured a quantity of stores and some prisoners. On the following morning Morgan returned and carried off thirty men from the Union camp, soon after which exploit he joined the rebel army near Murfreesboro'.

Col. Forrest's cavalry was also active in the same part of the State, but the vigorous measures of the Federal generals soon succeeded in checking this species of irregular warfare.

Some of the Federal soldiers, however, had been guilty of excesses hardly less outrageous than those of the guerillas, and rigid orders were issued by Gen. Grant to prevent it.

On the 7th of November, a portion of one of the Illinois regiments broke open a shop at Jackson, Tenn., and plundered and destroyed property to the value of some \$1,242. Gen. Grant ordered that sum to be assessed against the regiment, and such of its officers as were absent without leave at the time when the depredations were committed, the money when collected to be paid to the persons who had suffered by the outrage; and two officers who had failed to prevent it were mustered out of the service.

Toward the close of the same month, a plan was matured by the governor and Gen. Rosecrans for requiring bonds and sureties for good behavior from persons suspected as disunionists, or known to have been formerly secessionists.

On the 7th, a brigade of Gen. Dumont's division was captured by Col. Morgan, at Hartsville, near Nashville, having been surprised in their camp, and forced to surrender after a short and desultory resistance. The Confederate military authorities proclaimed a general conscription in Tennessee, and proceeded to draft into the Confederate army all able-bodied men under 40, in the portions of the State under their control. The Union men made a determined resistance, but in general, as might be supposed, with little effect. Even in Middle and West Tennessee, where the na-

tional arms were nominally paramount, the guerillas were employed to drive conscripts into the ranks. East Tennessee suffered still more severely, and it is stated that particular care was had to draft into the Confederate ranks those persons who were most conspicuous for their devotion to the Union.

In accordance with the President's order of October 21st, Governor Johnson, in the early part of December, issued a proclamation, calling for an election of representatives to the 37th Congress, to be held on the 29th, in the Ninth and Tenth Districts of Tennessee. The Ninth District embraces the counties of Henry, Weakly, Dyer, Oberon, Lauderdale, Tipton, Gipson, Carroll, and Henderson, and the Tenth includes the counties of Haywood, Madison, Hardeman, Fayette, and Shelby. The governor ends his proclamation with the notice that "no person will be considered an elector qualified to vote who, in addition to the other qualifications required by law, does not give satisfactory evidence to the judges holding the election, of his loyalty to the Government of the United States."

About the same time, Gov. Johnson published an order assessing the wealthy secessionists of Nashville and the vicinity to the amount of \$60,000, for the support of the poor during the winter.

On the 20th, a body of Confederate horsemen made a raid on the railroad near Jackson, in the western part of the State, burned a long trestle work, and tore up the track for a considerable distance. The day following, a small guerilla force entered the suburbs of Memphis, pillaged several shops, and carried off 100 cattle and 180 mules. As the armies of Gens. Bragg and Rosecrans began to prepare for battle, the guerilla raids became more numerous and more destructive; Nashville was again almost isolated, and the situation of the Union troops, in continual danger of having their supplies cut off, became extremely precarious. Soon after the close of the year, the Chattanooga "Rebel" published the following from an official source:

Gen. Morgan's report of his expedition shows that 2,000 prisoners were paroled, and several hundred of the enemy killed and wounded, and an immense quantity of arms and property destroyed.

Forrest's report shows 1,500 prisoners taken, 1,000 of the enemy killed and wounded, an immense quantity of arms, ammunition, and stores destroyed, and his whole command splendidly equipped from their captures.

Our operations at Murfreesboro', including the capture of 5,000 prisoners and the capture of 2,000 at Hartsville and around Nashville, sum up 10,000 prisoners in less than a month.

We have also captured and sent to the rear 30 cannon, 60,000 small arms, with 2,000 more in the hands of our troops; 1,500 wagons destroyed, and the mules and harnesses secured. The enemy's loss in killed and wounded is estimated at 20,000, including 7 generals.

The exploits of Cols. Forrest and Morgan referred to in this summary were performed principally in the latter half of December, but

VOL. II.—49 A

the greater part of the figures set down in the subsequent part of the article should be credited to the year 1863. For the more extensive military movements, and the battles in Tennessee, see ARMY OPERATIONS.

#### TERRITORIES OF THE UNITED STATES.

The Territories of the United States are constantly changing their form, by the admission of some of them into the Union as States, and the division and new organization of others in Territorial governments. The third session of the 37th Congress admitted Nevada, hitherto a Territory (organized in 1860), as a State, and organized two new Territories, Idaho, from the eastern part of Washington Territory, including the recently discovered gold regions of the Salmon, John Day, and Powder rivers; and Arizona, formerly the southern portion of New Mexico.

The Territories now existing (April, 1863) are Nebraska, Dakota, Idaho, Washington, Utah, Colorado, New Mexico, Arizona, and the Indian Territory.

NEBRASKA was organized in 1854, and the vote for its admission into the Union as a State passed one House and was lost by only a few votes in the other, at the second session of the 37th Congress. Its capital is Omaha City. Estimated area over 100,000 square miles. Population in 1860, 28,541, besides over 5,000 Indians. The governor, appointed by the President with the advice and consent of the Senate, is Alvin Saunders, whose official residence is at Omaha City. The Territorial secretary is Algernon S. Paddock, also residing at Omaha City. An election was held in the autumn for a delegate from the Territory to Congress, and Samuel G. Daly, republican, the delegate in the 37th Congress, was elected, receiving 2,333 votes, a majority of 153 over ——— Kenney, the democratic candidate. Nebraska raised two regiments of volunteers for the war, and at the time of the Indian invasion in Minnesota in Sept., 1862, a third regiment was called into the field for home service by the acting governor, A. S. Paddock, one of the other regiments from the Territory being also recalled for that service. There was some doubt whether the new mining region at the base of the Wind River Mountains, and on the headwaters of Grasshopper Creek, concerning which more will be said under Dakota, was not partly within the limits of Nebraska; it is probable at all events that the gold region extends into Nebraska. The new Territory of Idaho takes a long narrow strip from Nebraska, embracing the space between the 42d and 43d degrees of latitude from its western boundary to the 27th degree of west longitude.

DAKOTA is one of the three Territories organized by the 36th Congress in 1861. Its area is estimated at 825,000 square miles, and its population in 1860 was 44,501, of whom 89,664 were tribal Indians. Since its organization it has received a considerable addition to its white population. The capital is Yankton

on the Missouri river, about due west from Chicago, and 60 miles from the Iowa line. The governor to March, 1868, was Wm. Jayne, who was elected, in the autumn of 1862, delegate to the 38th Congress. The Territorial secretary was John Hutchinson. Both have their official residence at Yankton. The white population of the Territory was too small and too much scattered to permit of its furnishing any contingent for the war, but at the time of the Indian raid in Minnesota, some of the whites in the settlements bordering on that State were massacred, and all who were able volunteered for the punishment of the marauders. In the election for delegate to the 38th Congress, in Oct., 1862, William Jayne, republican, received 386 votes, a majority of 151 over J. B. S. Todd, democrat. On the official canvass the votes of Charles Mix and Bonhomme counties were thrown out for informality, and Gov. Jayne's majority was thus reduced to 16. Union Territorial officers (auditor and treasurer) were also chosen by a small majority. About the 1st of August, 1862, John White and ——— D'Orsay, miners from Colorado, who had started for the Salmon river mines in Washington co., commenced prospecting on Grasshopper creek or river (an affluent of the Yellowstone), near the summit of the Wind River Mountains, a spur of the Rocky Mountains, in the southwest corner of Dakota near the line of Nebraska. They soon found gold in great abundance, and other miners making discoveries of the precious metal in the vicinity, a government was organized by the miners, then about 250 in number, on the 27th of August, and the region named the Northwestern District. Subsequently two settlements were established, viz., Bannock City and Grasshopper Diggings, each of which, in Dec. 1862, contained over 1,000 inhabitants. The gold, mostly in the form of scales, proved very abundant, and the earnings of the miners were very large. It is supposed that gold deposits exist all along the eastern slope of the Rocky Mountains to the northern line of Dakota. Most of this region is now included in the new Territory of Idaho.

IDAHO is the name given to the new Territory organized by the 37th Congress at its late session. It extends from the eastern boundary of Oregon to the 27th degree of longitude west from Washington, and from the 42d to the 46th parallel of north latitude, and will have an area of about 125,000 square miles. Its capital will probably be Bannock City in the new gold region on the eastern slope of the Rocky Mountains, as it is most centrally situated, though Florence, in Idaho county, a village of 3,000 or 4,000 inhabitants in the Salmon river mining region, is now the largest town in the Territory. The discovery of extensive gold deposits on the Salmon and Nez Percé rivers (tributaries of the Snake river) in 1861 and 1862, has led to a rapid influx of population into this region. A good wagon road was completed in August last, by the Government, under the su-

perintendence of Lieut. Mullan, from Fort Benton, the head of navigation on the Missouri, to Fort Walla Walla on the Columbia river; it is 624 miles in length and passes through a country well watered and easily traversed.

WASHINGTON Territory was organized in 1853. Its capital is Olympia. The area was 176,141 square miles before Idaho was set off, and the estimated population in 1861, 14,249, aside from about 31,000 tribal Indians. Wm. Pickering is the governor, appointed by the President, and Elwood Evans secretary. The official residence of both is at Olympia. The Territory has a university at Seattle, for which buildings have been erected at a cost of about \$30,000, and which has received from the General Government an endowment of 46,080 acres of land. The Territory was too sparsely settled and too remote from the seat of war to be able to send any considerable number of troops to the army, though some volunteers have united with the contingent sent from the Pacific States. Extensive gold mines were discovered in 1861 on the tributaries of the Upper Columbia, known as the Wenatchee, O'Kanagon, Kettle river, and Colville mines, and in the autumn of the same year others on the Salmon and Nez Percé rivers, now included in Idaho. It was estimated that the gold sent to market from the Washington mines in 1862 was about \$5,000,000.

NEVADA, though now admitted into the Union, was a Territory during the whole of 1862. It was organized March 2, 1861, and has an estimated area of 80,000 square miles. Its population in 1860 was 50,568, of whom 23,811 were Indians. Its present population is said considerably to exceed 100,000. The capital is Carson City. The Territorial governor was James W. Nye, and the Territorial secretary Orion Clemens. The official residence of both is at Carson City.

Silver mining was the all-engrossing topic in this Territory during the year 1862. In the spring there was for a short period a lull in the speculation in mining stocks, but the discovery of numerous new lodes and veins, some of them very rich in silver, gave it a fresh impulse, and from August to December new companies with capital amounting in the aggregate to more than \$100,000,000 were organized in San Francisco and in Nevada Territory, three or four being often formed in a day. The Legislature of the Territory at its November session, 1862, passed a general incorporation bill requiring a majority of the trustees of these mining companies to be residents of the Territory, and protecting the stockholders and creditors against frauds, &c. The yield of the silver mines during the year was very large, amounting to nearly \$15,000,000, and would have been double or triple this amount could sufficient machinery and labor have been procured to extract the ore. The Ophir, Gould and Curry, and Comstock leads have been known favorably for two or three years for

their large yield of ore containing a heavy percentage of silver and some gold, and to these have been added the Monterey, Simpson's Park, Reese river, and numerous other leads equally valuable. The yield of several of these is from \$385 to \$1,093 worth of silver to each ton of ore, besides a small percentage of gold. The Territorial Government subscribed liberally to the Central Pacific Railroad to be constructed from Sacramento to Washoe, and to form a part of the line of the great Pacific Railway. The boundary line between Nevada and California had never been carefully run, and the attempt to define it led to some difficulty and collision, although the governors of California and Nevada endeavored to come to an amicable agreement in regard to it.

UTAH.—This Territory was organized in 1850. Its capital is Great Salt Lake City. Its area is 120,000 square miles, and its estimated population in 1862, 79,193, of whom about 20,000 are Indians; fully 50,000 of the whites are Mormons, or, as they term themselves, members of the "Church of Jesus Christ of the Latter Day Saints." The Territorial governor is Stephen S. Harding, and the Territorial secretary, Frank Fuller, both residing at Great Salt Lake City. The principal topic of interest in Utah during the year has been the organization by the citizens of the Territory of a State Government, and their urgent request to be admitted into the Union. On the 20th of January a convention, called in accordance with a resolution of the Territorial Legislature, met, and, on the 28d of January, had reported a State constitution, in its provisions essentially similar to those of most of the States. On the 3d of March the constitution was submitted to the people for ratification, and at the same time an election for State officers and member of Congress took place. The name of the State was to be "Deseret." The constitution was adopted by a vote of 9,879. Brigham Young was elected governor, receiving 9,980 votes (the whole number cast), Heber C. Kimball, lieutenant-governor, receiving 9,880 votes, and John Bernhisel (delegate from the Territory in the 37th Congress) representative in Congress, receiving 9,862 votes. The entire board of State officers and the State Legislature, elected at the same time, were Mormons, and bound to support the Mormon creed and practices, while the head of the Mormon Church was elected their chief magistrate. Senators were elected by the Legislature, which commenced its session April 14. Congress did not take action on their application during the session further than to refer it to the proper committee. A law "to punish and prevent polygamy" was passed by Congress, July 1, 1862, which was evidently intended for Utah, and a strip of land, the whole length of the Territory, and one degree in width, was taken from Utah, and annexed to Nevada. These measures did not please the authorities of Deseret, and loud threats were uttered in public

and private by the leaders of what they would do unless the State should be admitted without restriction. On the second Monday of December, 1862, the Territorial Legislature assembled, and Gov. Harding sent them a long Message, in which he avowed his determination to enforce the law of Congress for the punishment of polygamy, and discussed in very free and decided terms some of the derelictions of the Legislature and citizens of the Territory. There was manifested on both sides a considerable bitterness of feeling, which might at any time result in an outbreak. The 37th Congress did not at its third and final session admit the State of Deseret, and there were indications in the spring of 1863 of a collision between the Territorial and State authorities.

COLORADO.—This Territory, like Nevada and Dakota, was organized in March, 1861. Its capital is Denver City. Its area is about 100,000 square miles, and its estimated population in 1862 was about 70,000, of whom about 6,000 were tribal Indians. The Territorial governor is John Evans, and the Territorial secretary Samuel H. Elbert. The official residence of both is at Denver City. At the election, on the 1st Tuesday of October, Hiram P. Bennett, republican, was elected delegate to Congress by a plurality vote, receiving 3,655 votes, while William Gilpin, also republican, had 2,312, and ——— Francisco, democrat, 2,754. Colorado has raised for the war two regiments of cavalry, one of infantry, and a battery of artillery, besides a volunteer militia force organized at home to repel anticipated invasions from the Indians. The inhabitants of Colorado have shown themselves thoroughly loyal throughout the war. The gold mines of Colorado are very rich, and of a peculiar character, the gold being mostly deposited in connection with pyrites (sulphuret of iron, in a rotten quartz,) and these deposits grows richer the deeper they are mined. The gold raised in the Territory in 1862 amounted to about \$12,000,000, and could have been easily doubled with a sufficiency of labor and machinery. On the western slopes of the Snowy Mountains there are extensive silver deposits, as well as some gold mines; lead and quicksilver ores of great extent and value have also been discovered in the Territory, and immense beds of coal of good quality near Denver City—an important discovery, as the proposed route of the Pacific Railroad is directly past these coal beds, which will furnish the needed fuel, the want of which has hitherto been the greatest difficulty apprehended in the working of that gigantic enterprise.

INDIAN TERRITORY.—Under the head of Kansas the only incidents of interest in connection with this Territory, those relating to the expedition of the force of Gen. Blunt, have been mentioned. The capital of the Indian Territory is Tahlequah. The Territory contains 65,171 square miles, and had in 1860 a population of Indians and negroes of 65,380 persons.



**NEW MEXICO.**—This Territory was organized in 1850. Its capital is Santa Fé. Area, before Arizona was separated from it, 256,300 square miles; population, in 1860, 83,009, besides 55,100 tribal Indians. Territorial governor, Henry Connelly; Territorial secretary, W. F. M. Army. Both have their official residence at Santa Fé. The slave laws of the Territory were repealed in December, 1861. New Mexico, during the year 1862, was the theatre of some of the most desperate and hard-fought battles of the war. On the 4th of Jan., 1862, it was ascertained that a Texan force 1,500 strong, under command of the Confederate general Sibley, were approaching Fort Craig, 200 miles south of Santa Fé, which Col. E. R. Canby held with about 1,000 regular troops, and 1,500 volunteers. Finding the Federal force too strong to be attacked, Sibley and his Texans fell back, and did not again approach Fort Craig till they had been largely reinforced. In the last days of January, having received reinforcements, which brought his force up to fully 3,500, the Confederate general again advanced slowly and cautiously, in two columns, toward the fort. Col. Canby, hearing, on the 13th of February, from scouts and deserters, that the enemy were within 80 miles from Fort Craig, sallied out with a large force to meet and attack them, but could find no trace of them, and returned to the fort. On the 18th the Confederates appeared in front of the fort, about 2,000 strong, but retired the same day, and it was supposed commenced a retreat. Col. Canby despatched Major Duncan, with a squadron of dragoons and mounted men, to follow and harass them. The Texans retreated down the valley of the Rio Grande to a ravine about eight miles below the fort, where they had a battery of eight guns strongly planted. From this, after a sharp skirmish, Major Duncan was recalled. On the 19th and 20th the Texans attempted to cross the Rio Grande, in order to take possession of the heights opposite Fort Craig, but were driven back by the Federal forces without material loss on either side. On the 21st a desperate battle was fought, lasting most of the day, at a place called Valverde, about 10 miles below Fort Craig. Early in the morning the Federal forces captured 200 mules belonging to the Texans, and burned many of their wagons, and soon crossed the Rio Grande to attack them, with a battery of six pieces and two mountain howitzers. Both parties fought with the greatest desperation, the Texans, to capture the battery, the deadly execution of which cut them off from access to water, for want of which they and their animals were near perishing, and the Federal troops to hold the ground they had gained. The two howitzers were under command of Lieut. Hall, who successfully, and with great carnage, repulsed their attempts to capture them; the six-gun battery was commanded by Capt. McRae, and to the capture of this the main efforts of the Texans

were directed. They would not have succeeded, however, had not the New Mexican volunteers (Col. Pino's regiment) been panic-stricken and fled in great disorder, and the regulars refused to obey their commander. The Texans, repeatedly repulsed by the terrible fire of the battery, which was admirably served by Capt. McRae, finally came up to the charge, armed with only their long bowie knives and Colt's revolvers, and though more than half their number fell before they reached it, they finally succeeded in killing all the gunners, and capturing the battery. The brave McRae and his two lieutenants, Michler and Bell, stood at their guns when all the rest had fled, and defended themselves with their revolvers till they were killed. The loss of this battery compelled Col. Canby to fall back to Fort Craig. His loss was 62 killed and 140 wounded; that of the Confederates was very much greater, and effectually crippled their subsequent operations. They did not attempt to capture Fort Craig, but proceeded up the Rio Grande to Albuquerque and Santa Fé, both of which towns were evacuated by our forces, which fell back to Fort Union, 100 miles east of Santa Fé, a strong position, where the Government stores for the department were concentrated. Col. Canby intercepted and captured a force of 400 Texans on their way north to reinforce Gen. Sibley. Col. Slough, in command of a force of 1,800 Colorado mounted volunteers, reached Apache Pass, on the 26th of March, on his way to reinforce Col. Donelson at Fort Union, and there met a considerable force of Texans, whom, after a severe action, he routed, capturing 100 men and officers, killing and wounding between 300 and 400, and burning 50 loaded wagons. The Federal loss was less than 150 killed and wounded. On the 28th he had another battle at Pigeon's Rancho, 25 miles north of Santa Fé, and captured more prisoners and supplies. He then fell back to Fort Union, and there received orders from Col. (now General) Canby to form a junction with his forces at Galesto, which he accomplished on the 9th of April, and there learned that the Texans were retreating from the Territory. Major Duncan, commanding the advance guard of Gen. Canby's forces, had a battle with a body of Texans in the early part of April, and defeated them. Finding themselves hard pressed in their retreat, the Texans took a strong position at Parillo, on the Rio Grande, and fortifying it hastily, awaited an attack there about the middle of April; Gen. Canby attacked them in front, and sent Major Paul, in command of the Colorado troops, to assail them in the rear. After a sharp action, in which the Federal forces lost 25 killed and wounded, the Texans were defeated with great slaughter, and compelled to fly to the mountains. From this point their retreat was a succession of disasters; the destruction of the greater part of their train reduced them to the verge of starvation, and more than one half of the original number

were left in New Mexico, as killed, wounded, or prisoners. They reached Nussilla with five pieces of artillery and seven wagons, and even this scanty supply, the small remainder of the magnificent train with which they had invaded the Territory, was destined to be still further diminished before they reached El Paso. With bitter curses on their leaders, who had gone on in advance, and left them to take care of themselves, the half-starved and wretched remnant of the Texan troops, once the flower of the Texas chivalry, made their way, sadly and slowly, homeward, and every point which they left, as for instance, Nussilla, Fort Fillmore, Fort Bliss, and El Paso, was immediately occupied by loyal troops, under the efficient movements of Gen. Carleton.

ARIZONA.—This new Territory, organized in March, 1863, comprises about two fifths of the former territory of New Mexico, being all that portion lying S. of the line of 34° N. lat. The eastern portion, forming a part of the *Llano Estacado* or Staked Plains, is arid and not desirable for settlers; the western portion, watered by the Colorado and the Gila and its tributaries, has many fertile valleys and abundant mines of gold, silver, quicksilver, and copper of great productiveness. Many new mines, rivalling in richness the best of those in California, Idaho, or Colorado, were discovered in the summer of 1862. A new port, with a good harbor, near the head of the gulf of California, has been opened, and bids fair to open this region abounding in mineral wealth to the commerce of the world.

TEXAS, the most south-western of all the States, was so completely cut off from communication outside of the Confederacy, during the year 1862, that but little is known of the internal affairs of the State. The increase in the population of the State during the ten years ending June, 1860, was 391,622, of whom 131,405 were slaves. For the further details of the census of 1860 relative to this State the reader is referred to UNITED STATES.

The crops of the State in 1862 were good, and that of grain was the largest ever known. Beef, mutton, corn, and wheat were plentiful and cheap. Thousands of cattle were sent across the Mississippi to feed the Confederate army, and immense supplies of grain. In addition to these supplies, Texas furnished as many men to the army, in proportion to the population, as any other State. In July she had furnished forty-eight regiments, or forty-five thousand men, out of a voting population of sixty-four thousand. This number of troops was increased to sixty-four regiments. The conscript act was also fully enforced. Even many churches were abandoned by their pastors for the army. In the Confederate Congress, on a motion to authorize the President to receive into service any regiments of conscripts organized by any commanding officer west of the Mississippi, Mr. Oldham, the Senator from Texas, thus spoke of affairs there:

The section west of the Mississippi was as important as any part of the Confederacy; but regiments after regiments have been transported east of the Mississippi, and far beyond the Alleghany mountains, to fight battles in Virginia. I am proud of the fact that they were brought here, inasmuch as they were not needed at the time and were an enormous expense to the Government. The enemy are going to make one convulsive movement, and I think it will be their last. My impression is, that they will make an effort soon west of the Mississippi. I have received information from an officer in the Engineer Department that the enemy has obtained a footing upon the Gulf coast; they have possession of the Aransas Pass. They are building gunboats of light draft which they can run up the little streams and take possession of the entire coast. The troops of Arkansas are united with us by fate—the same destiny pertains to the one as to the other; and Missouri is linked in the same chain of good or ill fortune. The best troops of Texas you have transported east of the Mississippi, brought to Virginia, put into the hottest part of the contest, where they have been decimated, and now three fourths of each regiment from Texas sleep in their graves or have been discharged on account of sickness. Let this Government continue to draw on the fighting population of Texas to keep up these regiments and Texas will be ruined, irretrievably ruined. I think it is wrong and impolitic and unjust. My constituents have families, property, and homes to defend, and I protest against the men west of the Mississippi being transferred east of it, leaving their country open to the incursions of the enemy north, east, west, and south.

On the wild goose Sibley expedition thirty-five hundred of the very best troops of Texas were sent to perish on the arid plains of New Mexico, and they have only drawn the enemy upon our frontier, ready to come down upon us this winter. If the Government had sent these troops with other troops in Arkansas, and struck into Missouri, and there raised a hundred thousand men, which she would have furnished, seizing St. Louis, and made a diversion in favor of Tennessee and Kentucky, what would not have been accomplished that now remains to be done at the sacrifice of oceans of blood! I do not think it is just to deplete those States west of the Mississippi of their protective forces, that their troops should be brought away to fight the battles of the populous States.

Some military movements of interest took place on the coast. On the 17th of May the commander of the Federal naval forces before Galveston, Henry Eagle, summoned the place to surrender "to prevent the effusion of blood and the destruction of property which would result from the bombardment of the town," also stating that the land and naval forces would appear in a few days. The reply was that "when the land and naval forces made their appearance the demand would be answered." The city, however, was finally taken on the 8th of October. The military and the municipal authorities retired, and the inhabitants appointed a temporary mayor. On the morning of that day Commander Renshaw, with four steamers, approached so as to command the city with the guns of his vessels, and upon a signal the mayor came off to the flag ship. The mayor requested Commander Renshaw to communicate to him his intentions in regard to the city, informing him at the same time of its abandonment by the military, of the absence of the mayor and city council, and of his appointment as mayor pro tem. by a meeting of citizens.

Commander Renshaw replied that he had come for the purpose of taking possession of the city; that it was at his mercy under his guns; that he should not interfere in the municipal affairs of the city; that the citizens might go on and conduct their business as heretofore; that he did not intend to occupy the city for the present, or until the arrival of a military commander; but that he intended to hoist the United States flag upon the public buildings, and that his flag should be respected. Whereupon the mayor pro tem. answered that he could not guarantee to him the protection of the flag; that he would do everything in his power, but that persons over whom he had no control might take down the flag and create a difficulty.

Commander Renshaw replied that, although in his previous communications with the military commander he had insisted that the flag should be protected by the city, still he thought it would be onerous upon the good citizens; and, to avoid any difficulty like that which occurred in New Orleans, he would waive that point, and when he sent the flag ashore he would send a sufficient force to protect it, and that he would not keep the flag flying for more than a quarter or half an hour—sufficient to show the absolute possession.

Commander Renshaw further said that he would insist upon the right for any of his men in charge of an officer to come on shore and walk the streets of the city, but that he would not permit his men to come on shore indiscriminately or in the night; that, should his men insult citizens, he gave the mayor the right to arrest and report them to him, when he would punish them more rigidly than the mayor possibly could; but, on the other hand, should any of his men be insulted or shot at in the streets of Galveston, or any of his ships or boats be shot at from the land or wharves, he would hold the city responsible and open his broadsides on the same instantly; that his guns were kept shotted and double shotted for that purpose; that it was the determination of his Government to hold Galveston at all hazards until the end of the war.

Commander Renshaw thus held the city, in which a small military force was placed, until the 1st of January, when it was captured by the Texans. The Federal naval force in possession at this time consisted of the gunboats Westfield, Harriet Lane, Clifton, Owasco, Corypheus, and Sachem, the latter being broken down. The troops on shore were two hundred and fifty men under Col. Burnel, of the Massachusetts 42d regiment. On the night previous, information was received by the commanding officers of both the land and naval forces that such an attack would be made. At 1 30 A. M. on the night of the 1st two or three Confederate steamers were discovered in the bay by the Clifton and Westfield. Soon after the force on shore was informed by their pickets that the Confederate

artillery was in possession of the market place, about one quarter of a mile distant from the wharf on which they were quartered.

The attack commenced on shore about 3 A. M., by the enemy, upon the Federal troops, which were defended by the Sachem and Corypheus, with great energy, the troops only replying with musketry, having no artillery. About dawn the Harriet Lane was attacked, or, rather, attacked two Confederate steamers, one of which, the Bayou City, was armed with 68-pounder rifle guns, had 200 troops, and was barricaded with cotton bales, some twenty feet from the water line. The other, the Neptune, was similarly barricaded, and was armed with two small brass pieces and 160 men—(both were common river steamers). The Harriet Lane was under way in time, and went up to the attack, firing her bow gun, which was answered by the Confederates, but their 68-pounder burst at the third fire.

The Harriet Lane then ran into the Bayou City, carrying away her whole guard, passed her and gave her a broadside that did her little or no damage. The other Confederate steamer then ran into the Harriet Lane, but was so disabled by the collision that she was soon afterward obliged to back in on the flats, where she sunk in about eight feet of water, near to the scene of action. The Bayou City turned into the Harriet Lane, and she remained secured to her by catching under her guard, pouring in incessant volleys of musketry, as did the other steamer, which was returned by the Harriet Lane, with musketry. This drove the Harriet Lane's men from her guns, and probably wounded Commander Wainwright and Lieutenant Commander Lee—the latter mortally. She was then carried by boarding, by the Bayou City; her commander was summoned to surrender, which he refused to do, gallantly defending himself with his revolver until killed. But five of the Harriet Lane's men were killed, and five wounded. One hundred and ten, inclusive of officers and wounded men, were landed on shore, prisoners.

The Owasco, which had been anchored below the town, moved up at the commencement of the attack, and engaged the Confederate artillery on shore. When it was light enough for her to observe the two Confederate steamers alongside of the Harriet Lane, she moved up to her assistance, grounding several times, owing to the narrowness of the channel. Occasionally she brought her 11-inch gun to bear, but was soon driven off by the fire of the Confederate musketry. Soon the howitzers of the Harriet Lane opened on her, and she backed down below, continuing her engagement on shore. All her rifle gun crew were wounded.

The Clifton, before the action commenced, went around into Bolivar Channel to render assistance to the steamer Westfield, which had got under weigh when the Confederate steamers were first discovered. Soon after, she got

hard and fast ashore, at high water, and made a signal for assistance. When the Clifton was in the act of rendering this assistance, the flashes of the Confederate guns were first seen in the town. Commander Renshaw then directed Lieutenant Commander Law to leave him and to return to the town.

The moon had now gone down, and it became quite dark, yet the Clifton, with some difficulty, got around in the other channel, opening her batteries upon Fort Point, which the Confederates now had possession of, shelling them out and driving them up the beach as she neared the town. Here she anchored, and continued the engagement, but did not proceed up to the rescue of the Harriet Lane, owing to the failure of the Owasco, the intricacy of the channel, and the apprehension of killing the crew of the Harriet Lane, who were then exposed upon her upper deck. It was now about half past seven A. M. A white flag was hoisted on the Harriet Lane. A boat bearing a flag of truce, with a Confederate officer and an acting master of the Harriet Lane, came down to the Clifton, informing her commander of the capture of the Harriet Lane, the death of her commander and first lieutenant, and the killing and wounding of two thirds of her crew.

The proposition was made by the Confederate officer that all the Federal vessels should surrender, and one be allowed, with the crews of all, to leave the harbor, or they would proceed to capture them with the Harriet Lane and all their steamers, three more of which were in sight. These were neither armed nor barricaded. Upon being informed of this proposition, Commander Renshaw refused to consent, and directed Lieutenant Law to return and get all the vessels out of port as soon as possible, and, as he could not get the Westfield afloat, he should blow her up, and go on board the army transports Saxon and M. A. Bardman, then near him. Lieut. Law returned to execute these directions. Meanwhile, the Confederates had hauled the Harriet Lane alongside the wharf, and had made prisoners of the troops on shore, although it had been understood that all should remain *in statu quo* until the answer was returned. When the Clifton was half way toward the bar, her commander was informed by a boat from the Westfield, that, in the explosion of that vessel (which they observed some half an hour before), Commander Renshaw, Lieutenant Zimmerman, Engineer Green, and some ten or fifteen of the crew, had perished, the explosion being premature. Lieutenant Commander Law, now being commanding officer, proceeded to cross his vessel over the bar, and finally concluded to abandon the blockade altogether, considering the Owasco as his only efficient vessel, and regarding her as not equal to resist an attack from the Harriet Lane, should she come out for that purpose.

The vessels which were left in possession of

the Confederates were the Harriet Lane and two coal barks, the Oaralto and Elias Pike. The only injury sustained by the Harriet Lane appears to have been from a twelve-inch shell under her counter, fired by the Owasco, and the damage to her guard from the collision.

TWIGGS, DAVID EMANUEL, a major-general in the Confederate service, born in Georgia, in 1790, died in Augusta, Ga., Sept. 15, 1862. He entered the army as a captain in the 8th infantry in 1812, served throughout the war, and was afterward retained in service as captain in the 7th infantry, with the brevet rank of major. In the Mexican war he held the rank of colonel of the 2d dragoons, but acted as brigadier, commanding the right wing in the battles of Palo Alto and Resaca de la Palma, and in the same month was made brigadier-general. He was subsequently brevetted major-general for gallant and meritorious conduct at Monterey, and presented with a sword by Congress. In 1847 he was in command of a division under Gen. Scott, and the following year was military governor of Vera Cruz. At the commencement of the present war, he was in command of the Union troops in Texas, and through complicity with the Confederate leaders surrendered great quantities of military stores and material into the hands of the State authorities, and betrayed the troops under his charge to the Confederate authorities. For a short time he was in command at New Orleans, but very soon resigned, and after a retirement of a few months upon his estate in Mississippi, becoming alarmed at the approach of the Union troops, he removed to Augusta, Ga., where he died.

TYLER, JOHN, Ex-President of the United States, born in Charles City Co., Virginia, March 29, 1790, died in Richmond, Va., Jan. 18, 1862. He graduated at William and Mary College in 1807, studied law and was admitted to the bar in 1809 when but 19 years of age, and soon obtained a large and lucrative practice. In 1811 he was elected by an almost unanimous vote to the State Legislature, and continued in that body 5 years where he vigorously supported the war policy. He was elected to Congress in 1816 to fill a vacancy, and reelected in 1817 and 1819. He resigned in 1820 on account of ill health. In 1823-1825, he was again a member of the Legislature and in 1825 was elected by that body governor by a large majority over John B. Floyd. In 1826 he was again elected governor almost unanimously. He 1827 he was elected to the United States Senate, his competitor being the famous John Randolph, and both candidates avowing the same principles. At the expiration of his first term in the Senate in 1833 he was reelected. While in the Senate he opposed the administration of John Quincy Adams, though he had voted for him for the Presidency. He at first supported Gen. Jackson, but favored the nullification movement in South Carolina, and voted alone against the "Force Bill." He voted for the resolution of censure against Gen.

Jackson, for removing the deposits, as an arbitrary and illegal act, though he regarded the United States Bank as an unconstitutional institution. The Legislature of Virginia in 1836 instructed their Senators to vote for the expunging this resolution, and Mr. Tyler in consequence resigned his seat. In the Presidential campaign of 1836, he was supported in Maryland by the Whigs, and in other States by the friends of Judge White for the Vice Presidency, and thenceforward became identified with the Whig party, which in 1840 nominated him for the Vice Presidency on the ticket with General Harrison. He was elected, and in April, 1841, by the death of Gen. Harrison became President. His vetoes of two successive bank bills at the extra session of Congress which followed, and his seeking the support and counsel of leading democrats, lost him the confidence of the Whigs, and before the close

of his administration he had become in a degree identified with the democratic party, and finally selected his cabinet (of which John C. Calhoun was premier) wholly from that party. The most important measures of his administration were the general bankrupt act of 1841, the protective tariff of 1842, and the annexation of Texas, March 1, 1845. At the close of his administration he retired to private life, and held no public position again till February, 1861, when he was president of the Peace Conference at Washington. The measures he advocated there failing of success, he soon avowed himself a secessionist, and was elected a Senator from Virginia in the Confederate Congress at Richmond, which position he held at the time of his death. For a more full account of his political career and measures see *NEW AMERICAN CYCLOPEDIA*, Vol. xv, p. 683, Art. TYLER, JOHN.

## U

UHLAND, JOHANN LUDWIG, an eminent German poet, born in Tübingen, April 26, 1787, died in that city Nov. 13, 1862. He graduated at the University in Tübingen, receiving the degree of doctor of laws, and in 1810 visited Paris, where he applied himself to the study of the old French poets. He began the practice of law in Stuttgart, in which city he also held for some time a position in the office of the minister of justice. He was one of the noblest champions of the cause of liberty and democratic progress, and in 1814 published a volume of poems, the national songs of which became immensely popular during the great political excitement which resulted in the overthrow of the French rule in Germany. In 1819 and 1820 he was elected from Tübingen, and subsequently from Stuttgart, to the representative assembly of Wurtemberg. In 1829, having given up his legal practice, he became professor in the university of his native city, but resigned his post in consequence of not being able to attend the sittings at the Chamber. In 1839 he declined being a candidate for reelection and retired for several years to private life. After the crisis of 1848, the Wurtemberg ministry having sent him as a delegate to Frankfort, he took part in the reorganization of the Congress, where he sat on the left side, assisted at all the sessions, and migrated with the remainder of that body to Stuttgart, where, shortly afterward, the Wurtemberg Government dissolved the conference by force. From that period he withdrew from public life, living among his numerous friends, and giving himself up wholly to study. As a lyric poet, Uhland is one of the greatest Germany has ever produced, nor was his fame confined to his own country; he has been widely known and admired in England and America.

In 1815 he issued the first collection of his *Gedichte*. In 1836 appeared his work entitled

*Ueber den Mythos der nordischen Sagenlehre von Thor*, which was followed in 1845 by a collection of popular songs entitled, *Alter hoch- und niederdeutscher Volkslieder*, each being the result of profound researches into the history of the middle ages. Among his finest ballads are "Graf Eberhard der Greiner," and the legends from Suabian history.

UNITED STATES. The prosperity and growth of the United States during the ten years ending in June, 1860, exceeded in proportion that of any previous period of ten years since the organization of the Government. The labors of compiling the census returns have become so arduous that portions are published from time to time as the work progresses. The enumeration of the people and the collection of the other statistics required the services of sixty-four marshals, and 4,417 assistants. The compensation paid to them was \$1,045,206, less \$207,000 still due officers in the seceded States. In the compilation of the returns there are employed in the Census Bureau 168 clerks and 16 messengers, laborers, and watchmen.

Though the number of States has increased during the ten years ending in 1860, from thirty-one to thirty-four, and five new Territories were organized, the United States received no accessions of territory within that period except a narrow strip to the southward of the Colorado river, along the Mexican line, not yet inhabited. Good health generally prevailed, peace reigned, and there was no apparent interruption to the natural progress of the population. The increase was greater by more than one million of souls than the whole population in 1810, and nearly as great as the entire number of people in 1820. The gross returns of the population are to be found in this "Cyclopædia" for 1861. The returns, by sexes, and other details, are as follows:

POPULATION, DISTINGUISHED BY COLOR, CONDITION, AND SEX, 1850 AND 1860.

STATES AND TERRITORIES.	Whites.*						Free Colored.			
	Males.		Females.		Total.		Males.		Females.	
	1850.	1860.	1850.	1860.	1850.	1860.	1850.	1860.	1850.	1860.
Maine.....	296,745	316,580	285,068	310,422	581,813	626,952	724	659	630	668
New Hampshire.....	159,960	159,968	161,496	166,016	317,456	325,579	260	253	260	241
Vermont.....	159,653	183,415	153,744	155,974	313,402	314,389	875	871	848	833
Massachusetts.....	454,093	599,244	501,337	629,220	955,450	1,221,464	4,424	4,469	4,640	5,133
Rhode Island.....	70,340	82,302	73,535	85,965	143,875	170,685	1,788	1,831	1,932	2,121
Connecticut.....	179,884	321,855	182,215	229,662	368,099	451,520	3,820	4,136	3,573	4,491
New York.....	1,544,459	1,910,354	1,509,836	1,921,376	3,048,825	3,831,730	23,452	23,173	25,617	25,827
New Jersey.....	293,452	322,733	282,057	323,966	485,509	646,699	11,798	12,312	12,012	13,006
Pennsylvania.....	1,142,784	1,427,946	1,115,426	1,421,520	2,258,160	2,849,266	25,969	26,373	23,257	30,475
Delaware.....	85,746	45,940	85,423	44,649	171,169	90,559	9,085	9,859	9,083	9,940
Maryland.....	211,187	256,839	206,756	259,079	471,943	518,918	35,192	39,746	39,581	44,196
District of Columbia.....	18,494	29,555	19,447	31,179	37,941	60,764	4,448	4,702	5,311	6,429
Virginia.....	451,300	528,597	443,500	518,514	894,800	1,047,411	26,092	27,721	25,331	30,321
North Carolina.....	273,025	314,267	280,003	316,833	553,023	631,100	13,298	14,850	14,165	15,533
South Carolina.....	137,747	146,201	136,816	145,187	274,563	291,388	4,131	4,548	4,329	5,366
Georgia.....	266,233	301,053	253,399	290,505	521,572	591,588	1,375	1,669	1,556	1,831
Florida.....	25,705	41,129	21,498	36,619	47,208	77,748	418	454	514	473
Alabama.....	219,433	270,271	207,081	256,160	426,514	526,431	1,056	1,254	1,209	1,436
Mississippi.....	156,257	156,275	139,431	167,626	295,715	353,901	474	852	456	891
Louisiana.....	141,243	189,733	114,248	167,891	255,491	357,629	7,479	8,279	9,938	10,363
Texas.....	84,869	228,797	69,165	192,497	154,034	421,294	211	151	186	174
Arkansas.....	55,874	171,501	76,315	152,690	102,189	324,191	314	72	294	72
Tennessee.....	352,235	422,510	374,601	403,972	756,896	826,732	3,117	3,538	3,305	3,762
Kentucky.....	392,804	474,211	368,609	445,306	761,413	919,517	4,863	5,101	5,148	5,533
Ohio.....	1,004,117	1,171,720	950,933	1,131,118	1,955,050	2,302,833	12,691	13,398	12,588	13,266
Michigan.....	208,465	391,127	186,606	351,187	395,071	742,314	1,431	3,567	1,132	3,232
Indiana.....	506,178	698,469	470,976	645,531	977,154	1,389,000	5,715	5,791	5,547	5,637
Illinois.....	445,544	598,952	400,490	505,371	846,034	1,104,323	2,777	3,809	2,659	3,819
Wisconsin.....	164,851	406,796	140,405	367,914	304,756	774,710	365	653	270	518
Minnesota.....	3,695	99,391	2,348	79,665	6,098	173,596	21	126	18	133
Iowa.....	100,857	333,927	90,994	319,917	191,851	673,844	165	581	168	523
Missouri.....	312,987	563,144	279,017	500,365	592,004	1,068,509	1,361	1,697	1,237	1,875
Kansas.....	58,592	106,579	47,657	106,579	59,000	106,579	286	286	...	...
California.....	84,708	270,510	6,927	105,398	91,635	375,908	872	2,827	90	1,259
Oregon.....	8,133	31,515	4,949	20,822	13,057	52,337	120	76	87	52
Washington.....	...	8,420	...	3,144	...	11,564	...	26	...	4
Nevada.....	...	6,102	...	710	...	6,812	...	35	...	10
Utah.....	6,020	20,224	5,310	19,990	11,330	40,214	14	13	10	17
New Mexico.....	31,725	49,046	29,800	44,385	61,525	93,431	17	45	5	9
Colorado.....	...	82,654	...	1,577	...	84,231	...	37	...	...
Nebraska.....	...	16,719	...	12,040	...	28,759	...	35	...	32
Dakota.....	...	2,797	...	2,940	...	4,837	...	...	...	...
Total.....	10,026,402	13,869,434	9,526,666	13,133,890	19,533,068	27,003,314	208,724	234,000	225,771	253,996

STATES AND TERRITORIES.	Free Colored.		Slaves.				Aggregate.	
	Total.		Males.		Females.		Total.	
	1850.	1860.	1850.	1860.	1850.	1860.	1850.	1860.
Maine.....	1,856	1,327	...	...	...	...	583,169	623,279
New Hampshire.....	520	494	...	...	...	...	317,976	326,073
Vermont.....	718	709	...	...	...	...	314,120	315,098
Massachusetts.....	9,064	9,602	...	...	...	...	994,514	1,231,066
Rhode Island.....	3,670	3,952	...	...	...	...	174,545	174,545
Connecticut.....	7,693	8,627	...	...	...	...	370,792	460,147
New York.....	49,069	49,005	...	...	...	...	3,097,394	3,890,735
New Jersey.....	23,810	25,818	...	...	...	...	459,555	672,035
Pennsylvania.....	53,626	56,849	...	...	...	...	2,311,786	2,906,115
Delaware.....	13,073	19,829	1,174	860	1,116	938	2,290	1,798
Maryland.....	74,723	83,942	45,944	44,313	44,424	42,576	90,863	87,189
District of Columbia.....	10,059	11,181	1,422	1,212	2,265	1,973	3,687	3,185
Virginia.....	54,393	58,042	240,562	249,438	231,966	241,382	472,528	490,865
North Carolina.....	27,463	30,463	144,581	166,469	143,967	164,590	288,548	331,059
South Carolina.....	8,960	9,914	187,756	196,571	197,223	205,835	384,984	402,406
Georgia.....	2,931	3,500	188,857	229,193	192,285	233,005	381,682	482,195
Florida.....	932	932	19,804	31,348	19,506	30,397	39,310	61,745
Alabama.....	2,265	2,690	171,804	217,766	171,400	217,314	342,844	435,080
Mississippi.....	930	773	154,674	219,301	154,626	217,330	309,573	436,631
Louisiana.....	17,462	13,647	125,874	171,977	118,963	159,749	244,809	331,726
Texas.....	397	855	38,700	91,189	29,461	91,377	58,161	182,566
Arkansas.....	608	144	23,658	56,174	23,442	54,941	47,100	111,115
Tennessee.....	6,422	7,300	118,780	136,370	120,679	139,349	239,459	275,719
Kentucky.....	10,011	10,634	105,063	113,009	105,918	112,474	210,981	225,433
Ohio.....	25,279	36,664	...	...	...	...	...	1,980,329
Michigan.....	2,583	6,799	...	...	...	...	...	2,339,502
Indiana.....	11,262	11,428	...	...	...	...	...	397,654
Total.....	11,262	11,428	...	...	...	...	...	988,416

\* Including taxed Indians and Chinese as follows: Maine, 5; Vermont, 20; Massachusetts, 32; Rhode Island, 19; Connecticut, 16; New York, 140; Pennsylvania, 7; Virginia, 112; North Carolina, 1,158; South Carolina, 88; Georgia, 38; Florida, 1; Alabama, 160; Mississippi, 2; Louisiana, 173; Texas, 403; Arkansas, 48; Tennessee, 60; Kentucky, 33; Ohio, 30; Michigan, 2,515; Indiana, 290; Illinois, 32; Wisconsin, 1,017; Minnesota, 2,369; Iowa, 65; Missouri, 20; Kansas, 189; California, 37,903 (including 23,140 Chinese); Oregon, 177; Washington, 426; Utah, 89; New Mexico, 10,507; Nebraska, 63; Dakota, 2,261; District of Columbia, 1; total, 60,469, of whom 37,329 were Indians and 23,140 Chinese, and 42,078 males and 13,391 (7,249 of both races in California) females.

## POPULATION, DISTINGUISHED BY COLOR, CONDITION, AND SEX, 1850 AND 1860—(Continued.)

STATES AND TERRITORIES.	Free Colored.		Slaves.						Aggregate.	
	Total.		Males.		Females.		Total.		1850.	1860.
	1850.	1860.	1850.	1860.	1850.	1860.	1850.	1860.		
Illinois.....	5,486	7,628	....	....	....	....	....	....	851,470	1,711,951
Wisconsin.....	635	1,171	....	....	....	....	....	....	805,891	775,881
Minnesota.....	89	259	....	....	....	....	....	....	6,077	178,855
Iowa.....	338	1,104	....	....	....	....	....	....	192,214	674,943
Missouri.....	2,618	3,572	43,484	57,360	43,938	57,571	87,422	114,981	682,044	1,182,612
Kansas.....	....	625	....	....	....	2	....	2	....	107,206
California.....	962	4,086	....	....	....	....	....	....	92,597	879,994
Oregon.....	207	128	....	....	....	....	....	....	13,294	52,465
Washington.....	....	80	....	....	....	....	....	....	1,201	11,594
Nevada.....	....	45	....	....	....	....	....	....	....	6,857
Utah.....	....	80	12	18	14	11	26	29	11,880	40,373
New Mexico.....	....	85	....	....	....	....	....	....	61,547	63,516
Colorado.....	....	46	....	....	....	....	....	....	....	34,377
Nebraska.....	....	67	....	6	....	9	....	15	....	28,841
Dakota.....	....	....	....	....	....	....	....	....	....	4,887
Total.....	434,449	487,996	1,602,245	1,982,625	1,601,490	1,971,135	3,204,318	3,958,760	23,191,876	31,445,080

## DEATHS IN THE UNITED STATES, BY MONTHS AND BY SEX, 1860.

MONTHS.	Number recorded			Proportions.			State registry.
	Males.	Females.	Total.	Males.	Females.	Total.	
January.....	17,587	15,156	32,693	4.42	3.82	8.24	7.60
February.....	17,791	16,208	33,999	4.79	4.37	9.16	7.75
March.....	20,569	18,473	39,042	5.18	4.65	9.83	8.11
April.....	19,396	17,593	36,929	5.03	4.58	9.61	7.88
May.....	21,865	19,376	40,741	5.33	4.88	10.26	7.25
June.....	14,323	13,223	27,546	3.73	3.44	7.17	6.81
July.....	16,151	14,351	30,532	4.08	3.62	7.70	8.01
August.....	13,287	16,553	34,845	4.61	4.17	8.78	10.99
September.....	17,243	15,552	33,095	4.49	4.13	8.62	11.40
October.....	15,457	13,692	29,149	3.89	3.45	7.34	8.51
November.....	13,194	11,365	24,559	3.44	2.96	6.40	7.45
December.....	14,614	12,753	27,367	3.63	3.21	6.89	7.94
Unknown.....	1,383	986	2,324	....	....	....	....
Total.....	207,235	185,586	392,821	52.72	47.28	100.00	100.00

## DEATHS CLASSIFIED BY AGES AND BY SEX, 1860.

AGES.	Number enumerated.			Proportions.			
	Males.	Females.	Total.	Males.	Females.	Total, 1860.	Total, 1850.
0—1.....	44,480	36,794	81,274	11.85	9.39	20.74	16.90
1—2.....	20,588	17,643	38,236	5.25	4.51	9.76	....
2—3.....	12,493	11,153	23,646	3.19	2.85	6.04	....
3—4.....	7,567	7,083	14,650	1.93	1.81	3.74	21.41
4—5.....	5,332	5,147	10,479	1.36	1.31	2.67	....
5—10.....	13,822	13,637	27,459	3.53	3.43	7.01	6.63
10—15.....	6,969	6,763	13,737	1.69	1.73	3.86	4.12
15—20.....	8,111	9,265	17,376	2.07	2.36	4.43	4.79
20—25.....	10,598	10,551	20,949	2.65	2.69	5.94	11.74
25—30.....	9,452	9,560	19,012	2.41	2.44	4.85	....
30—40.....	16,224	15,343	31,567	4.14	3.92	8.06	9.07
40—50.....	13,470	10,322	23,992	3.44	2.63	6.12	7.14
50—60.....	11,902	8,514	20,416	3.04	2.17	5.21	5.56
60—70.....	11,284	8,323	20,107	2.88	2.25	5.13	5.12
70—80.....	8,995	8,009	17,004	2.30	2.05	4.35	4.17
80—90.....	4,776	4,508	9,584	1.22	1.23	2.45	2.54
90—.....	1,284	1,590	2,874	0.33	0.41	0.74	0.76
Unknown.....	683	371	1,059	....	....	....	....
Total.....	207,235	185,586	392,821	52.72	47.28	100.00	100.00

UNITED STATES.

TABLE SHOWING THE POPULATION OF THE PRINCIPAL CITIES AND TOWNS IN THE UNITED STATES, ACCORDING TO THE SEVENTH CENSUS (1850) AND THE EIGHTH CENSUS (1860), RESPECTIVELY; ALSO THE NUMERICAL INCREASE AND INCREASE PER CENT.

The letter *l* indicates loss.

CITIES AND TOWNS.	Population in 1850.	Population in 1860.	Increase.	Increase per cent.	CITIES AND TOWNS.	Population in 1850.	Population in 1860.	Increase.	Increase per cent.
Albany, N. Y.	50,768	62,267	11,604	22.86	Manchester, N. H.	18,923	30,109	6,177	44.83
Alleghany City, Pa.	21,261	28,702	7,441	35.00	Mobile, Ala.	20,515	22,258	8,748	42.61
Augusta, Ga.	11,758	12,498	740	6.30	Montgomery, Ala.	4,985	35,022	30,067	607.49
Augusta, Me.	8,225	7,609	l 4,488	l 54.32	Millwaukee, Wis.	20,061	45,246	25,185	125.54
Auburn, N. Y.	9,549	10,936	1,488	15.06	Marblehead, Mass.	6,167	7,547	1,480	23.99
Alexandria, Va.	8,784	19,652	3,913	44.86	Middleborough, Mass.	5,256	6,272	936	17.94
Ann Arbor, Mich.	4,386	4,458	l 7.91	l 0.18	Memphis, Tenn.	8,889	22,622	18,754	211.54
Annapolis, Md.	8,011	4,529	1,518	50.49	Muscatine, Iowa	2,540	5,324	2,784	109.60
Alton, Ill.	8,585	7,283	3,758	104.49	Madison, Ind.	8,019	8,180	113	1.47
Baltimore, Md.	169,054	212,418	43,364	25.65	New Haven, Conn.	20,245	29,267	18,922	93.00
Buffalo, N. Y.	42,261	81,199	38,968	91.97	New York, N. Y.	515,547	805,651	290,104	56.27
Boston, Mass.	136,881	177,819	40,981	29.90	Newark, N. J.	28,984	71,914	38,020	84.59
Bangor, Me.	14,432	16,407	1,975	13.68	Norfolk, Va.	14,226	15,811	1,585	8.96
Bath, Me.	8,029	8,076	56	0.70	Nashville, Tenn.	10,478	16,988	6,510	62.18
Burlington, Vt.	6,110	7,718	1,608	26.24	New Brunswick, N. J.	10,019	11,225	1,207	12.26
Burlington, N. J.	4,586	5,193	657	14.48	New Orleans, La.	116,875	163,673	52,900	44.94
Burlington, Iowa	4,082	6,706	2,624	64.28	Nashua, N. H.	5,820	10,065	4,245	72.98
Brooklyn, N. Y.	96,538	266,661	169,283	175.37	Nantucket, Mass.	9,572	13,001	l 27.59	
Camden, N. J.	9,479	14,858	4,379	51.47	Newburyport, Mass.	9,572	9,899	4,000	40.00
Charleston, S. C.	42,985	40,573	l 2,412	l 5.63	Newport, R. I.	9,563	10,515	945	9.88
Cincinnati, Ohio.	115,486	161,044	45,608	39.51	New London, Conn.	8,991	10,165	1,174	13.05
Columbus, Ohio.	17,889	18,534	679	3.76	Newburg, N. C.	11,415	13,122	875	8.31
Cleveland, Ohio.	17,984	42,417	24,388	154.88	Newbern, N. C.	4,461	6,412	751	16.94
Charlestown, Mass.	17,984	25,068	7,847	43.58	Natchez, Miss.	4,494	6,812	2,179	49.12
Chicago, Ill.	29,968	109,260	79,297	264.65	Norwich, Conn.	10,285	14,047	3,739	36.54
Cambridge, Mass.	15,315	26,600	10,485	71.82	Pekin, Ill.	1,678	2,467	1,789	106.61
Canandaigua, N. Y.	6,148	7,075	923	15.17	Portland, Me.	20,815	26,341	5,526	26.54
Columbia, S. C.	6,980	8,039	1,059	22.08	Portsmouth, N. H.	9,788	9,385	l 4.13	
Columbus, Ohio.	17,889	18,229	340	1.90	Portsmouth, Va.	8,122	5,822	1,980	16.99
Columbus, Ga.	9,342	9,221	8,679	61.91	Providence, R. I.	41,513	50,662	9,158	22.04
Chillicothe, Ohio.	7,100	7,226	526	7.40	Philadelphia, Pa.	840,045	668,522	222,484	26.48
Detroit, Mich.	21,019	45,819	24,600	117.08	Pittsburgh, Pa.	45,601	49,217	2,616	5.61
Dover, N. H.	8,196	8,502	306	3.73	Petersburg, Va.	14,010	13,266	4,256	30.88
Dayton, Ohio.	10,870	20,951	9,111	88.03	Plymouth, Mass.	6,024	4,272	782	4.12
Davenport, Iowa.	3,108	12,267	9,119	509.63	Poughkeepsie, N. Y.	18,944	14,736	824	7.58
Dubuque, Iowa.	8,108	18,000	9,892	120.77	Paterson, N. J.	11,824	19,538	8,204	72.58
Des Moines, Iowa.	936	8,265	2,270	302.12	Peoria, Ill.	5,095	14,045	8,950	175.66
Fall River, Mass.	11,524	14,026	2,502	21.71	Quincy, Ill.	6,902	13,682	6,780	97.51
Frederick, Md.	6,028	8,143	2,115	35.08	Rochester, N. Y.	26,408	43,204	11,501	43.43
Fayetteville, N. C.	4,446	4,790	144	3.09	Richmond, Va.	27,570	37,910	10,940	39.50
Fredericksburg, Va.	4,061	5,022	961	23.66	Roxbury, Mass.	18,804	26,187	6,773	35.98
Freeport, Ill.	1,486	3,529	2,092	145.75	Reading, Pa.	15,748	28,161	7,413	47.12
Fort Wayne, Ind.	4,302	10,383	6,106	142.59	Raleigh, N. C.	4,519	4,730	262	5.80
Gardiner, Me.	4,436	4,457	l 21	l 0.47	Richmond, Ind.	1,448	6,808	5,160	357.51
Gloucester, Mass.	7,736	10,904	3,118	40.04	Rock Island, Ill.	1,711	5,190	8,419	199.32
Georgetown, D. C.	5,286	8,783	367	4.83	Springfield, Mass.	11,766	15,199	3,438	29.18
Galveston, Texas.	4,177	7,807	3,180	74.98	Salem, Mass.	20,264	22,252	1,988	9.81
Galena, Ill.	6,004	8,193	2,189	36.45	Syracuse, N. Y.	22,271	23,119	8,843	39.68
Hartford, Conn.	18,535	29,154	15,599	115.03	Savannah, Ga.	15,812	22,292	6,990	45.69
Hudson, N. Y.	8,896	7,187	901	14.83	St. Louis, Mo.	77,960	180,773	82,913	106.49
Harrisburg, Pa.	7,584	13,405	5,711	71.11	San Francisco, Cal.	24,778	56,902	22,026	63.84
Ithaca, N. Y.	6,909	6,549	l 360	l 5.21	Schenectady, N. Y.	8,921	9,579	658	7.38
Indianapolis, Ind.	8,084	18,611	10,577	131.65	Steubenville, Ohio	6,140	6,154	14	0.16
Iowa City, Iowa.	1,582	5,214	3,632	229.58	Thomaston, Me.	2,728	3,218	495	18.18
Jersey City, N. J.	6,536	29,226	22,870	326.23	Trenton, N. J.	6,461	20,223	13,767	213.07
Keokuk, Iowa	2,473	3,186	5,603	223.82	Troy, N. Y.	28,765	39,232	10,447	36.29
Lowell, Mass.	28,858	26,927	3,444	10.81	Taunton, Mass.	10,441	15,876	4,935	47.27
Louisville, Ky.	43,194	63,088	24,899	57.50	Utica, N. Y.	17,665	22,529	4,964	28.36
Lynn, Mass.	14,357	19,083	4,926	34.30	Vicksburg, Miss.	3,678	4,591	913	24.83
Lockport, N. Y.	12,823	18,222	1,900	9.78	Washington, D. C.	40,001	61,122	21,121	52.78
Lawrence, Pa.	12,839	17,608	5,294	42.81	Wilmington, N. C.	7,294	9,552	2,288	31.50
Lynchburg, Va.	8,071	6,538	l 1,533	l 18.99	Worcester, Mass.	17,049	24,960	7,911	46.40
Lexington, Ky.	9,180	9,221	171	1.85	West Troy, N. Y.	7,664	8,920	1,256	16.60
La Fayette, Ind.	1,215	9,257	3,173	272.59	Wilmington, Del.	18,979	21,503	7,529	39.66
Lansing, Mich.	1,229	3,074	1,945	150.12	Wheeling, Va.	11,435	14,058	2,643	23.16
La Porte, Ind.	1,524	5,023	3,204	176.65	Zanesville, Ohio.	10,855	9,229	l 1,626	l 14.87



AGRICULTURAL STATISTICS OF THE UNITED STATES FOR THE YEARS 1850 AND 1860.

STATES AND TERRITORIES.	Acres of improved land in farms.		Acres of unimproved land in farms.		Cash value of farms.		Cash value of implements and machinery.		Horses.	
	1850.	1860.	1850.	1860.	1850.	1860.	1850.	1860.	1850.	1860.
Maine.....	2,039,596	2,677,216	2,515,797	3,023,539	\$54,861,748	\$78,690,725	\$2,284,557	\$3,298,327	41,721	60,683
New Hampshire.....	2,251,488	2,367,089	1,140,926	1,377,591	55,245,997	69,689,761	2,314,125	2,682,412	34,233	41,191
Vermont.....	2,601,409	2,758,443	1,524,413	1,402,396	63,867,227	91,511,673	2,739,282	3,554,728	61,057	67,250
Massachusetts.....	2,133,436	2,155,512	1,222,576	1,183,212	109,076,347	123,255,948	3,209,584	3,894,998	42,216	47,156
Rhode Island.....	356,487	329,884	197,451	189,814	17,070,809	19,385,573	497,201	587,241	6,168	7,121
Connecticut.....	1,768,173	1,890,808	615,701	673,457	72,726,427	90,530,005	1,892,541	2,389,451	26,879	33,376
New York.....	12,408,964	14,376,397	6,710,120	6,616,553	554,546,642	803,343,593	22,084,926	29,166,895	447,014	503,725
New Jersey.....	1,767,991	1,944,445	984,955	1,039,086	120,237,511	180,250,335	4,425,508	5,746,567	63,955	72,707
Pennsylvania.....	8,628,619	10,463,806	6,294,728	6,548,847	407,376,099	662,050,707	14,729,541	22,442,842	250,398	437,654
Delaware.....	580,562	637,065	375,282	367,230	18,850,081	31,426,357	510,279	817,838	18,352	16,262
Maryland.....	2,797,905	3,002,269	1,896,445	1,833,306	87,178,545	145,978,677	2,463,443	4,010,259	75,634	93,406
District of Columbia.....	16,267	16,267	11,187	16,789	1,730,460	2,989,267	40,220	54,410	824	641
Virginia.....	10,360,135	11,435,954	15,792,176	19,578,946	216,401,543	371,696,211	7,021,772	9,381,006	272,403	237,222
North Carolina.....	5,453,975	6,517,284	15,543,008	17,245,685	37,891,766	143,301,005	3,381,532	5,573,492	148,698	150,661
South Carolina.....	4,072,651	4,572,060	12,145,049	11,623,860	82,491,663	139,632,508	4,136,354	6,151,657	97,171	81,125
Georgia.....	6,378,479	8,062,758	16,442,900	18,587,732	95,738,445	157,072,803	5,894,150	8,544,887	151,331	130,771
Florida.....	349,049	676,464	1,246,240	2,273,005	6,323,109	16,371,684	658,795	888,980	10,848	18,424
Alabama.....	4,435,614	6,462,987	7,702,067	12,687,913	64,323,224	172,176,168	5,125,663	7,287,599	123,001	137,305
Mississippi.....	3,444,358	5,150,008	7,046,061	11,703,556	54,738,694	156,566,914	5,762,927	8,664,816	115,460	117,134
Louisiana.....	1,590,925	2,734,901	3,899,018	6,765,879	75,814,898	215,566,421	11,576,938	20,891,888	89,514	72,063
Texas.....	6,437,976	2,649,207	10,852,363	20,486,990	16,550,008	104,007,629	2,151,704	6,114,362	76,760	320,621
Arkansas.....	731,580	1,933,036	1,816,684	7,609,938	15,265,245	91,678,403	1,601,296	4,024,114	60,197	101,249
Tennessee.....	5,175,173	6,897,974	13,808,849	18,457,969	97,851,212	272,555,054	5,360,210	8,871,095	270,636	292,545
Kentucky.....	5,968,270	7,644,217	10,981,478	11,519,059	155,021,262	291,496,955	5,169,037	7,474,573	113,629	325,704
Ohio.....	9,851,493	12,665,587	8,146,000	8,075,551	358,758,603	666,564,171	12,750,585	16,790,256	463,367	632,229
Michigan.....	1,929,110	3,419,561	2,454,780	3,511,581	51,872,446	163,279,087	2,891,371	5,855,642	58,200	154,163
Indiana.....	5,046,543	8,161,717	7,746,879	8,154,059	136,385,173	344,909,776	6,704,444	10,290,826	314,299	409,204
Illinois.....	5,039,545	13,251,473	6,997,567	7,993,557	96,138,290	432,331,072	6,405,561	18,726,160	267,638	575,161
Wisconsin.....	1,045,499	3,746,036	1,931,159	4,153,134	16,528,563	117,811,092	1,641,568	5,768,347	30,179	116,192
Minnesota.....	5,035	554,397	23,546	2,222,734	161,948	19,070,737	15,981	1,044,009	860	17,132
Iowa.....	824,682	3,780,253	1,911,382	5,649,136	16,657,567	118,741,405	1,172,689	5,190,042	38,536	174,837
Missouri.....	2,938,425	6,246,571	6,794,245	13,737,939	63,225,543	230,682,126	3,931,255	8,711,058	225,319	361,574
Kansas.....	.....	372,535	.....	1,284,626	.....	11,394,184	.....	675,896	.....	13,832
California.....	32,454	2,430,882	3,861,531	6,533,585	8,374,041	14,671,994	103,438	2,443,297	21,719	160,335
Oregon.....	132,857	595,375	299,951	5,816,817	4,249,170	46,755,385	138,423	949,103	8,046	36,600
Washington.....	.....	.....	.....	300,897	.....	1,116,292	.....	202,506	.....	5,005
Utah.....	16,333	16,333	30,516	58,598	311,799	1,637,854	84,288	255,854	2,429	5,145
New Mexico.....	166,201	166,201	124,370	1,177,055	1,653,922	2,701,626	77,960	194,005	5,079	10,119
Nebraska.....	.....	.....	.....	501,723	.....	3,916,002	.....	150,082	.....	4,522
Dakota.....	.....	.....	.....	24,333	.....	97,335	.....	15,574	.....	34

STATES AND TERRITORIES.	Asses and Mules.		Milk cows.		Working oxen.		Other cattle.		Sheep.	
	1850.	1860.	1850.	1860.	1850.	1860.	1850.	1860.	1850.	1860.
Maine.....	55	104	133,556	147,315	83,593	79,792	125,890	149,827	451,577	452,472
New Hampshire.....	19	10	94,277	94,880	50,027	51,512	114,606	118,005	884,756	310,534
Vermont.....	213	35	146,133	171,693	45,677	42,959	154,143	149,359	1,014,122	731,983
Massachusetts.....	34	10	130,099	144,492	46,611	38,221	83,284	97,201	183,631	114,329
Rhode Island.....	1	10	15,693	19,700	8,139	7,827	9,875	11,548	44,296	32,024
Connecticut.....	49	82	85,461	95,877	46,983	47,939	80,226	95,091	734,151	117,107
New York.....	963	1,553	931,324	1,123,634	178,909	121,702	767,406	727,837	453,241	2,617,533
New Jersey.....	4,089	6,362	117,736	138,813	12,070	10,067	80,453	89,909	160,483	133,235
Pennsylvania.....	2,259	8,532	530,224	673,547	61,527	60,371	562,195	685,575	1,522,257	1,631,540
Delaware.....	791	2,294	19,243	22,595	9,797	9,330	24,166	25,596	27,603	15,337
Maryland.....	5,644	9,239	86,856	99,463	34,135	34,324	95,365	119,254	177,902	153,765
District of Columbia.....	57	122	813	639	104	69	123	150	150	40
Virginia.....	21,483	41,014	317,619	330,627	59,513	97,862	669,137	615,696	1,310,004	1,042,946
North Carolina.....	23,259	51,383	221,799	228,623	87,303	45,511	434,402	416,676	595,249	346,749
South Carolina.....	37,433	56,456	193,244	163,933	20,507	22,629	563,335	525,551	333,599	233,590
Georgia.....	57,379	101,069	334,223	299,638	73,286	74,437	690,019	637,707	560,433	513,613
Florida.....	5,002	19,909	72,876	92,704	5,794	7,737	182,415	284,736	29,311	29,033
Alabama.....	59,325	108,701	227,791	234,045	66,961	92,495	432,263	452,648	371,530	369,061
Mississippi.....	54,517	112,438	214,291	207,134	33,485	104,184	436,254	413,559	304,929	337,754
Louisiana.....	44,349	92,320	105,576	130,672	54,968	61,003	414,793	329,855	116,333	130,355
Texas.....	12,463	63,000	217,311	598,036	51,285	172,423	61,013	2,733,267	100,530	158,615
Arkansas.....	11,539	44,158	93,131	158,873	34,239	70,944	165,320	313,535	91,256	202,674
Tennessee.....	75,303	119,221	270,436	247,103	83,255	104,495	414,051	408,874	111,591	773,317
Kentucky.....	63,609	117,635	247,475	269,215	62,351	108,999	442,763	457,545	1,109,001	933,990
Ohio.....	3,423	6,917	544,439	696,309	65,381	61,760	743,067	901,751	8,949,292	8,063,837
Michigan.....	70	339	99,676	200,635	55,330	55,549	119,471	237,633	746,435	1,465,477
Indiana.....	6,599	18,627	254,354	491,033	40,221	93,982	339,801	531,090	1,129,433	2,137,375
Illinois.....	10,573	38,581	294,671	532,731	76,156	90,973	541,209	831,777	884,043	775,330
Wisconsin.....	156	1,919	64,339	193,996	42,301	93,660	76,293	225,210	124,896	332,434
Minnesota.....	14	305	607	40,386	655	27,574	740	51,043	280	13,123
Iowa.....	74	5,713	45,704	188,546	21,592	56,563	69,125	291,145	149,960	233,223
Missouri.....	41,667	80,941	230,169	345,243	112,165	166,538	449,173	657,153	762,511	937,445
Kansas.....	.....	1,430	.....	26,726	.....	20,133	.....	.....	.....	15,702
California.....	1,666	13,744	4,250	98,559	4,770	31,527	233,599	952,043	17,574	1,075,713
Oregon.....	420	900	9,427	53,072	8,114	7,426	24,188	95,001	15,382	75,936
Washington.....	.....	173	.....	10,094	.....	2,777	.....	16,072	.....	10,162
Utah.....	325	973	.....	13,052	3,266	9,903	2,439	17,369	.....	37,838
New Mexico.....	8,654	11,255	10,635	34,461	12,257	26,104	10,085	29,228	377,271	836,459
Nebraska.....	.....	473	.....	7,125	.....	12,720	.....	8,570	.....	1,757
Dakota.....	.....	19	.....	2-6	.....	348	.....	388	.....	33

AGRICULTURAL STATISTICS.—Continued.

STATES AND TERRITORIES.	Swine.		Value of live stock.		Value of animals slaughtered.		Wheat, bushels.		Eys, bushels.	
	1850.	1860.	1850.	1860.	1850.	1860.	1850.	1860.	1850.	1860.
Maine.....	54,598	54,788	\$9,705,796	\$15,487,588	\$1,646,778	\$2,780,179	296,259	228,877	102,916	123,290
New Hampshire.....	63,487	51,985	8,871,901	10,924,627	1,523,873	3,737,500	135,658	228,966	183,117	123,248
Vermont.....	66,296	49,438	12,643,328	15,884,898	1,861,836	2,549,001	585,955	431,127	176,238	180,976
Massachusetts.....	81,119	73,948	9,647,710	12,787,744	2,500,924	2,915,045	31,911	119,788	481,021	388,085
Rhode Island.....	19,509	17,478	1,632,637	2,042,044	667,436	718,725	49	1,181	26,409	23,259
Connecticut.....	76,472	75,120	7,467,490	11,911,079	2,202,266	3,181,992	41,762	52,401	600,398	618,702
New York.....	1,018,259	910,178	78,570,499	108,856,296	18,578,888	15,841,408	18,121,499	8,651,100	4,148,182	4,786,905
New Jersey.....	250,870	236,089	10,679,391	16,194,698	2,683,552	4,120,376	1,601,190	1,763,128	1,255,578	1,489,497
Pennsylvania.....	1,040,866	1,081,266	41,500,058	69,672,726	8,219,848	18,899,878	15,867,691	18,043,281	4,806,160	5,474,792
Delaware.....	56,261	47,848	1,949,381	8,144,706	878,665	573,075	452,511	912,941	8,066	27,209
Maryland.....	852,911	887,756	7,997,684	14,667,858	1,954,900	9,821,510	4,494,680	6,108,480	226,014	513,901
District of Columbia.....	1,635	1,099	109,640	109,640	9,083	65,440	17,370	12,760	5,509	6,989
Virginia.....	1,339,348	1,589,519	88,656,659	47,794,256	7,502,936	11,488,441	11,912,616	18,129,180	453,980	944,024
North Carolina.....	1,812,818	1,338,214	17,717,647	81,180,905	5,767,866	10,414,546	2,130,102	4,748,706	229,568	486,856
South Carolina.....	1,065,508	965,779	15,060,015	28,984,465	8,502,687	6,072,822	1,066,277	1,285,681	43,790	89,091
Georgia.....	2,163,617	2,086,116	26,839,416	88,873,784	2,689,762	10,908,204	1,088,934	2,544,918	58,750	115,523
Florida.....	209,458	274,814	2,830,058	5,490,789	514,685	1,201,441	1,027	2,503	1,152	21,314
Alabama.....	1,904,540	1,736,959	21,690,112	48,061,905	4,823,435	10,825,022	294,044	1,222,467	17,261	73,942
Mississippi.....	1,532,734	1,584,997	19,408,662	40,245,079	3,684,582	7,528,007	137,990	679,452	9,606	41,260
Louisiana.....	997,801	642,955	11,152,275	24,751,822	1,453,990	2,058,736	417	29,283	475	12,759
Texas.....	692,022	1,363,878	10,412,927	52,899,984	1,116,137	5,218,957	41,729	1,464,273	3,105	95,012
Arkansas.....	886,727	1,155,379	6,647,969	22,040,211	1,163,318	3,395,899	199,639	955,293	8,047	77,569
Tennessee.....	3,104,800	2,348,948	29,973,016	61,257,874	6,401,765	12,845,696	1,619,866	5,409,568	89,137	265,844
Kentucky.....	2,861,163	2,380,595	29,661,436	61,963,237	6,462,598	11,640,740	2,142,822	7,894,311	415,073	1,055,262
Ohio.....	1,964,770	2,175,623	44,121,741	80,488,730	7,489,248	14,298,972	14,487,351	14,532,570	425,913	656,146
Michigan.....	205,847	874,664	8,003,784	28,920,086	1,328,827	4,080,720	4,925,859	8,818,155	105,371	494,197
Indiana.....	2,263,776	2,493,528	22,478,555	50,116,964	6,667,935	9,562,322	6,214,453	15,219,120	73,792	400,226
Illinois.....	1,915,907	2,279,732	24,209,258	78,484,621	4,572,256	15,159,948	4,414,575	24,159,600	88,364	961,322
Wisconsin.....	159,276	888,957	4,397,385	17,907,866	920,178	3,868,710	4,266,181	15,812,625	81,253	888,594
Minnesota.....	734	101,229	92,859	8,655,866	2,840	732,418	1,401	2,195,312	125	124,259
Iowa.....	823,247	921,161	8,639,275	21,776,736	821,164	4,408,468	1,580,531	8,438,205	19,916	176,035
Missouri.....	1,702,825	2,354,425	19,587,930	68,698,673	3,867,106	9,344,449	2,931,652	4,227,568	44,263	293,262
Kansas.....	.....	193,909	.....	8,205,592	.....	547,450	.....	1,682,527	.....	3,393
California.....	2,776	453,523	8,351,053	36,601,154	107,178	8,562,587	17,328	5,946,619	.....	51,244
Oregon.....	30,233	79,660	1,876,159	6,273,992	164,530	640,196	211,948	822,403	106	2,714
Washington.....	.....	9,836	.....	1,147,631	.....	105,109	.....	92,609	.....	244
Utah.....	.....	10,730	546,963	1,729,012	67,925	263,752	107,702	382,697	210	870
New Mexico.....	9,114	9,439	1,494,629	4,386,064	82,125	809,168	56,516	446,075	.....	1,800
Nebraska.....	.....	25,985	.....	1,216,823	.....	100,755	.....	72,263	.....	1,185
Dakota.....	.....	287	.....	89,116	.....	875	.....	945	.....	700

STATES AND TERRITORIES.	Indian corn, bushels.		Oats, bushels.		Rice, lbs.		Tobacco, lbs.		Ginned cotton, bales (400 lbs. each).	
	1850.	1860.	1850.	1860.	1850.	1860.	1850.	1860.	1850.	1860.
Maine.....	1,750,066	1,546,071	2,181,087	2,968,989	.....	.....	.....	1,658	.....	.....
New Hampshire.....	1,573,670	1,414,628	978,891	1,829,213	.....	.....	50	21,881	.....	.....
Vermont.....	2,082,896	1,468,200	2,907,734	3,511,603	.....	.....	.....	12,158	.....	.....
Massachusetts.....	2,345,490	2,157,063	1,165,146	1,180,075	.....	.....	183,246	3,283,193	.....	.....
Rhode Island.....	589,201	458,912	115,232	284,453	.....	.....	.....	705	.....	.....
Connecticut.....	1,935,043	2,059,585	1,258,788	1,522,213	.....	.....	1,267,624	6,000,188	.....	.....
New York.....	17,853,400	30,061,043	96,532,814	95,175,188	.....	1,120	88,159	5,764,532	.....	.....
New Jersey.....	8,759,704	9,273,886	8,378,063	4,599,182	.....	.....	810	149,485	.....	.....
Pennsylvania.....	19,883,214	23,196,921	21,588,156	27,887,149	.....	.....	912,651	8,181,536	.....	.....
Delaware.....	8,145,542	8,392,887	604,519	1,046,910	.....	.....	.....	9,699	.....	.....
Maryland.....	10,749,858	18,444,922	2,242,151	8,959,298	.....	.....	21,407,497	83,410,963	.....	.....
Dist. of Columbia.....	63,290	80,840	8,184	99,548	.....	.....	.....	7,800	.....	15,200
Virginia.....	25,354,319	38,860,704	10,179,144	10,184,965	17,154	8,225	56,908,227	128,967,737	8,947	19,727
North Carolina.....	37,941,051	30,803,564	4,052,073	2,761,860	5,465,868	7,599,976	11,984,736	32,858,250	73,845	145,514
South Carolina.....	16,271,454	15,065,606	2,822,155	986,974	159,930,618	119,100,828	74,235	104,412	800,901	858,418
Georgia.....	30,090,099	30,776,293	8,820,044	1,281,817	83,950,691	52,507,652	423,924	919,316	499,091	701,340
Florida.....	1,996,800	2,324,538	66,586	46,779	1,075,090	223,200	993,614	758,015	45,181	66,063
Alabama.....	23,754,043	32,761,194	2,963,696	716,485	2,812,252	499,559	164,990	921,284	564,429	933,651
Mississippi.....	32,448,532	29,563,785	1,608,288	191,088	2,719,856	657,293	49,960	127,756	484,292	1,202,055
Louisiana.....	10,266,373	16,205,856	89,637	65,945	4,425,849	6,455,017	26,878	40,610	173,777	722,944
Texas.....	6,023,876	16,521,898	199,017	983,313	83,208	25,670	66,897	98,016	58,072	415,251
Arkansas.....	8,893,380	17,758,663	656,138	602,566	67,179	215	213,938	999,757	63,344	866,465
Tennessee.....	52,278,223	50,748,266	7,793,096	2,848,122	258,354	80,516	20,143,982	88,981,277	194,832	212,019
Kentucky.....	53,672,591	64,048,693	8,201,311	4,617,029	5,688	24,407	56,501,196	108,102,483	733	4,092
Ohio.....	59,073,635	70,637,140	18,472,742	15,479,183	.....	.....	10,454,449	25,598,272	.....	.....
Michigan.....	5,641,420	19,152,110	2,866,056	4,078,093	.....	.....	.....	1,245	.....	.....
Indiana.....	52,964,363	69,641,591	6,585,014	5,023,755	.....	.....	1,219	1,044,620	7,260,182	14
Illinois.....	57,648,984	115,396,779	10,827,241	13,886,072	.....	.....	.....	841,394	7,014,230	6
Wisconsin.....	1,988,979	7,585,290	8,414,672	11,059,370	.....	.....	.....	1,963	67,593	.....
Minnesota.....	16,725	2,937,570	80,583	2,920,050	.....	.....	.....	.....	83,510	.....
Iowa.....	8,656,799	41,116,994	1,524,345	5,879,638	.....	.....	.....	6,041	812,919	.....
Missouri.....	36,214,387	73,899,157	5,378,079	8,650,370	700	9,767	17,118,784	25,056,196	.....	101½
Kansas.....	.....	5,673,884	.....	80,744	.....	.....	.....	16,978	.....	.....
California.....	12,236	524,357	.....	957,634	.....	1,800	.....	1,000	.....	.....
Oregon.....	2,918	74,566	61,214	900,204	.....	.....	.....	825	.....	.....
Washington.....	.....	4,799	.....	158,001	.....	.....	.....	.....	.....	.....
Utah.....	9,399	98,361	10,900	138,086	.....	.....	.....	70	10	1,188
New Mexico.....	865,411	710,605	5	7,491	.....	.....	8,467	6,999	.....	.....
Nebraska.....	.....	1,846,735	.....	79,977	.....	.....	.....	8,801	.....	.....
Dakota.....	.....	30,296	.....	2,540	.....	.....	.....	.....	.....	.....

AGRICULTURAL STATISTICS.—Continued.

STATES AND TERRITORIES.	Wool, lbs.		Fens and beans, bushels.		Irish potatoes, bushels.		Sweet potatoes, bushels.		Barley, bushels.	
	1880.	1889.	1880.	1889.	1880.	1889.	1880.	1889.	1880.	1889.
	Maine.....	1,264,084	1,485,068	905,541	246,918	3,484,040	6,374,017	.....	1,485	151,731
New Hampshire.....	1,108,478	1,160,319	70,866	79,435	4,904,919	4,187,548	.....	161	70,356	121,168
Vermont.....	3,400,717	2,973,544	104,649	63,912	4,951,014	5,147,908	.....	622	42,150	73,226
Massachusetts.....	583,186	377,267	43,709	43,246	3,583,334	3,201,901	.....	616	112,383	134,521
Rhode Island.....	129,992	90,999	6,846	7,699	631,028	542,909	.....	946	18,379	40,396
Connecticut.....	497,454	335,956	19,090	23,864	2,689,728	1,538,148	.....	80	2,710	19,999
New York.....	10,071,801	9,454,473	741,546	1,609,334	15,395,363	24,447,339	5,629	7,522	3,535,059	4,189,967
New Jersey.....	375,396	349,350	14,174	27,675	3,307,236	4,171,690	508,015	1,064,833	8,492	24,915
Pennsylvania.....	4,481,570	4,752,523	55,251	123,064	5,980,733	11,631,463	53,172	108,190	165,864	330,716
Delaware.....	57,768	50,301	4,120	7,483	240,542	377,931	63,443	143,218	56	3,446
Maryland.....	477,438	491,511	12,816	24,407	764,939	1,264,429	208,992	22,744	745	17,359
District of Columbia.....	525	100	7,754	4,749	23,292	31,738	8,497	4,191	75	178
Virginia.....	2,960,765	2,509,443	521,579	515,004	1,816,996	2,229,118	1,813,634	1,960,808	25,437	63,729
North Carolina.....	970,739	883,473	1,584,252	1,982,204	620,313	580,565	5,093,709	6,140,039	2,735	3,445
South Carolina.....	437,338	427,102	1,026,900	1,723,074	184,494	224,730	4,387,469	4,115,698	4,588	11,699
Georgia.....	990,019	946,329	1,142,011	1,763,214	237,379	316,352	6,954,423	5,608,541	11,601	14,623
Florida.....	23,247	59,594	135,359	964,783	1,622	13,549	707,226	1,218,958	.....	16
Alabama.....	657,113	651,404	692,701	1,433,609	246,001	397,566	5,473,204	5,420,937	3,858	14,738
Mississippi.....	559,619	687,729	1,072,737	1,966,353	261,433	401,504	4,741,795	4,343,491	323	1,396
Louisiana.....	109,397	396,187	161,732	490,410	95,632	332,722	1,423,453	2,070,941	.....	144
Texas.....	131,917	1,497,743	179,330	359,560	94,645	163,937	1,332,153	1,333,306	4,776	33,395
Arkansas.....	182,595	140,253	235,738	439,412	193,332	418,000	753,149	1,462,714	177	3,079
Tennessee.....	1,364,373	1,400,506	869,321	550,918	1,067,844	1,174,647	2,777,716	2,614,555	2,737	23,439
Kentucky.....	2,297,433	2,323,124	202,574	283,319	1,492,437	1,736,532	993,179	1,067,568	95,348	270,829
Ohio.....	10,196,871	10,643,161	60,163	105,219	5,037,739	5,732,573	157,997	297,908	354,535	1,601,923
Michigan.....	2,043,338	4,762,558	74,234	182,193	2,359,397	3,264,733	1,177	36,225	73,249	303,914
Indiana.....	2,610,237	2,463,264	35,773	77,701	2,068,337	3,732,180	201,711	224,804	45,438	224,574
Illinois.....	2,150,118	2,477,568	32,814	112,624	2,514,581	3,799,964	107,433	841,448	110,739	1,176,651
Wisconsin.....	353,968	1,011,915	20,637	99,304	1,402,077	3,545,505	379	2,345	209,692	673,997
Minnesota.....	65	22,740	10,002	13,502	276,120	2,027,945	200	751	1,216	173,199
Iowa.....	373,393	638,068	4,775	43,570	21,143	2,700,515	2,243	50,933	23,098	434,116
Missouri.....	1,627,164	2,069,773	46,017	107,999	939,006	1,990,350	335,503	335,102	9,331	223,539
Kansas.....	.....	22,698	.....	10,167	.....	233,968	.....	9,221	.....	413
California.....	5,520	2,681,922	2,292	194,932	9,292	1,647,293	1,000	158,001	9,712	4,307,770
Oregon.....	29,656	303,943	6,566	84,616	91,326	311,700	.....	335	.....	24,608
Washington.....	.....	90,720	.....	33,005	.....	191,334	.....	19	.....	1,739
Utah.....	9,222	75,633	289	3,135	43,968	140,370	60	.....	1,799	13,333
New Mexico.....	33,901	479,345	15,638	33,554	3	8,304	.....	180	5	6,009
Nebraska.....	.....	3,312	.....	4,503	.....	169,762	.....	168	.....	1,949
Dakota.....	.....	.....	.....	236	.....	9,459	.....	.....	.....	.....

STATES AND TERRITORIES.	Buckwheat, bushels.		Value of orchard products.		Wine, gallons.		Value of market-garden products.		Butter, lbs.	
	1880.	1889.	1880.	1889.	1880.	1889.	1880.	1889.	1880.	1889.
	Maine.....	104,533	339,520	\$342,365	\$501,767	794	3,165	\$122,387	\$194,006	9,243,511
New Hampshire.....	65,256	89,996	248,568	557,934	344	9,401	56,810	76,256	6,977,056	6,954,794
Vermont.....	209,519	215,521	315,255	198,427	659	9,228	18,838	24,792	12,197,980	15,661,334
Massachusetts.....	105,895	128,202	463,995	925,579	4,638	20,915	600,020	337,025	9,071,370	8,237,936
Rhode Island.....	1,345	8,573	63,994	83,691	1,013	507	96,298	146,661	3,950,670	1,014,336
Connecticut.....	229,297	309,107	175,118	508,848	4,269	45,738	196,374	1,397,323	6,492,119	7,620,913
New York.....	3,188,935	5,126,805	1,761,950	3,726,390	9,173	61,404	912,047	831,596	79,766,904	108,977,519
New Jersey.....	378,934	377,836	607,263	429,403	1,311	21,038	475,242	1,542,155	9,487,310	10,714,447
Pennsylvania.....	2,193,692	5,572,026	728,839	1,479,938	25,590	38,628	668,714	1,334,970	89,378,418	58,633,511
Delaware.....	8,615	16,355	46,574	114,225	145	633	12,714	37,797	1,056,308	1,439,503
Maryland.....	103,671	212,338	164,051	252,196	1,431	3,222	200,369	530,221	3,906,160	5,235,226
District of Columbia.....	378	445	14,343	9,930	863	118	67,222	139,106	14,372	18,335
Virginia.....	214,398	477,503	177,137	300,650	5,430	40,506	183,047	539,411	11,069,359	13,461,713
North Carolina.....	16,704	35,924	34,843	643,633	11,058	54,064	39,462	75,668	4,146,290	4,735,495
South Carolina.....	233	602	35,106	213,939	5,930	24,964	47,236	137,343	2,961,350	3,177,334
Georgia.....	250	2,023	92,776	176,043	796	27,646	76,500	201,916	4,640,559	5,433,735
Florida.....	65	.....	1,230	21,716	10	1,661	8,721	18,213	371,493	404,470
Alabama.....	848	1,334	15,403	213,323	220	19,130	84,321	135,151	4,006,311	6,123,793
Mississippi.....	1,121	1,740	50,405	259,330	407	10,106	46,250	124,608	4,344,234	5,111,133
Louisiana.....	3	160	22,359	110,923	15	5,030	143,329	390,742	688,069	1,440,943
Texas.....	59	1,612	12,505	46,802	99	13,946	12,354	55,943	2,344,900	5,943,611
Arkansas.....	175	433	40,141	56,230	85	1,005	17,150	38,094	1,354,239	4,062,431
Tennessee.....	19,427	14,421	52,394	314,269	92	13,562	97,133	274,163	8,139,555	10,000,323
Kentucky.....	16,097	18,929	106,230	604,351	3,093	179,949	303,120	453,246	9,947,523	11,716,099
Ohio.....	693,060	2,327,005	695,921	1,333,673	48,207	562,640	214,004	360,313	34,449,379	50,493,743
Michigan.....	472,917	600,435	132,650	1,137,678	1,654	13,733	14,733	145,053	7,062,376	14,650,834
Indiana.....	149,740	367,797	324,940	1,212,142	14,055	83,270	72,964	238,070	12,581,533	17,394,737
Illinois.....	134,504	345,069	446,409	1,145,936	2,997	47,093	127,494	418,195	12,526,548	23,337,516
Wisconsin.....	79,378	67,822	4,323	76,096	118	9,511	32,142	207,153	3,633,730	18,631,036
Minnesota.....	515	27,677	.....	293	.....	394	150	94,631	1,100	2,961,391
Iowa.....	52,516	216,524	4,334	131,234	420	3,706	3,343	141,549	2,171,138	11,523,002
Missouri.....	23,641	132,292	514,711	310,975	10,663	27,327	99,454	346,400	7,334,359	12,704,337
Kansas.....	.....	86,739	.....	724	.....	241	.....	36,353	.....	1,012,975
California.....	.....	36,436	17,700	607,459	53,055	494,516	75,273	1,074,143	705	3,333,500
Oregon.....	.....	2,635	1,271	474,934	.....	2,603	90,241	36,333	211,464	1,012,339
Washington.....	.....	977	.....	23,779	.....	179	.....	27,749	.....	137,333
Utah.....	332	96	.....	9,230	.....	60	23,368	45,465	33,309	203,333
New Mexico.....	100	6	8,231	19,701	2,363	3,201	6,679	17,640	111	3,333
Nebraska.....	.....	12,329	.....	161	.....	631	.....	9,630	.....	3,333
Dakota.....	.....	.....	.....	115	.....	.....	.....	500	.....	1,333

AGRICULTURAL STATISTICS.—Continued.

STATES AND TERRITORIES.	Cheese, lbs.		Hay, tons.		Clover seed, bushels.		Other grass-seeds, bushels.		Hops, lbs.	
	1850.	1860.	1850.	1860.	1850.	1860.	1850.	1860.	1850.	1860.
	Maine.....	2,484,454	1,799,862	755,889	975,716	9,097	48,851	9,214	6,907	40,120
New Hampshire.....	8,196,568	2,232,092	598,854	642,741	829	11,992	8,071	5,573	257,174	130,428
Vermont.....	8,720,834	8,077,689	66,163	919,066	760	2,444	14,936	11,420	288,023	631,641
Massachusetts.....	7,088,142	5,294,090	651,807	665,331	1,002	1,295	5,085	4,852	121,595	111,301
Rhode Island.....	316,508	177,252	74,818	82,725	1,328	1,221	3,708	4,229	277	50
Connecticut.....	5,963,277	3,893,411	516,131	562,425	13,841	13,671	16,628	13,024	554	959
New York.....	49,741,413	48,548,288	3,728,797	3,564,786	88,222	106,933	96,493	81,622	2,536,299	9,655,542
New Jersey.....	365,756	182,172	435,950	508,729	28,280	39,208	63,051	85,410	2,133	3,722
Pennsylvania.....	2,505,084	2,508,556	1,842,970	2,245,420	125,030	274,363	53,913	57,204	22,088	41,576
Delaware.....	3,187	6,579	80,159	36,973	2,525	3,595	1,403	1,165	348	414
Maryland.....	3,975	8,342	157,956	191,744	15,217	39,511	2,561	3,195	1,870	2,943
District of Columbia.....	1,500	2,279	8,180	3,180	8	8	.....	.....	15	15
Virginia.....	436,292	280,792	369,098	445,529	29,727	36,961	23,428	59,063	11,506	10,015
North Carolina.....	95,921	51,119	145,653	181,365	576	332	1,275	3,008	9,246	1,767
South Carolina.....	4,970	1,543	20,925	37,592	376	28	80	38	26	122
Georgia.....	46,976	15,557	28,449	46,448	132	635	428	1,914	261	199
Florida.....	18,015	3,754	2,510	7,594	.....	.....	2	.....	14	.....
Alabama.....	31,412	9,607	32,685	55,219	138	187	547	653	276	1,069
Mississippi.....	21,191	3,419	12,504	32,885	84	217	533	1,175	473	221
Louisiana.....	1,957	5,494	25,752	46,999	2	.....	97	701	125	8
Texas.....	95,399	277,512	8,354	11,849	10	449	.....	2,976	7	122
Arkansas.....	30,088	16,952	8,276	8,276	90	60	436	3,110	137	164
Tennessee.....	177,631	126,794	74,091	146,027	5,096	8,062	9,118	41,532	1,032	2,329
Kentucky.....	218,954	190,400	113,747	158,484	3,230	2,308	21,481	62,563	4,309	5,899
Ohio.....	20,819,542	23,758,738	1,443,142	1,602,518	103,197	216,545	37,810	53,475	63,731	22,344
Michigan.....	1,011,492	2,009,064	404,934	756,908	16,989	49,480	9,285	6,555	10,663	61,704
Indiana.....	624,564	569,574	403,230	635,322	18,320	45,321	11,951	31,866	92,796	75,053
Illinois.....	1,278,225	1,595,358	601,952	1,334,265	3,427	16,687	14,350	202,808	3,551	7,129
Wisconsin.....	400,283	1,104,459	275,662	533,799	483	3,848	5,003	26,338	15,930	135,587
Minnesota.....	.....	198,904	2,019	274,952	.....	156	.....	2,314	.....	149
Iowa.....	209,540	901,220	89,055	707,260	342	1,564	2,096	69,482	8,242	1,797
Missouri.....	203,572	259,633	116,925	401,070	619	2,216	4,346	55,713	4,130	2,265
Kansas.....	.....	28,038	.....	50,812	.....	98	.....	2,633	.....	130
California.....	150	1,564,857	2,038	306,741	.....	4	.....	162	.....	10
Oregon.....	36,980	82,456	373	26,441	4	307	22	3,793	8	137
Washington.....	.....	12,146	.....	4,871	.....	116	.....	211	.....	23
Utah.....	30,998	21,325	4,805	20,026	2	3	.....	101	50	95
New Mexico.....	5,848	37,250	.....	1,103	.....	2	.....	.....	.....	.....
Nebraska.....	.....	15,762	.....	25,320	.....	5	.....	206	.....	41
Dakota.....	.....	.....	.....	1,122	.....	35	.....	.....	.....	.....

STATES AND TERRITORIES.	Dew-rotted hemp, tons.		Water-rotted hemp, tons.		Other prep'd hemp, tons.	Flax, lbs.		Flax seed, bushels.		Silk cocoons, lbs.	
	1850.	1860.	1850.	1860.		1850.	1860.	1850.	1860.	1850.	1860.
	Maine.....	..	..	..		..	50	17,081	2,997	550	489
New Hampshire.....	..	18	..	50	13	7,652	1,947	189	31	191	..
Vermont.....	..	2	..	1	.....	20,552	5,107	939	331	268	..
Massachusetts.....	..	..	..	..	.....	1,162	165	72	7	7	7
Rhode Island.....	..	..	..	..	.....	85	.....	.....	.....	.....	.....
Connecticut.....	..	3	..	..	.....	17,928	1,187	703	109	323	18
New York.....	1	32,191	3	99	3,531	940,577	1,514,476	57,963	56,986	1,774	259
New Jersey.....	..	230	..	..	200	182,965	48,657	16,525	3,241	23	..
Pennsylvania.....	44	1,640	..	189	2,174	530,307	310,080	41,723	24,209	285	163
Delaware.....	..	..	..	..	.....	11,174	8,112	904	2,126	9	9
Maryland.....	63	18	..	..	254	35,636	14,481	2,446	1,570	39	3
District of Columbia.....	..	..	..	..	.....	.....	.....	.....	.....	.....	.....
Virginia.....	88	5	51	3	4	1,000,450	487,330	52,313	30,673	517	225
North Carolina.....	36	..	3	..	3,016	593,796	216,490	38,196	20,008	229	338
South Carolina.....	..	1	..	..	.....	333	344	55	313	123	20
Georgia.....	..	1	..	..	30	5,887	3,303	622	96	813	72
Florida.....	..	..	..	..	1	50	.....	.....	.....	.....	.....
Alabama.....	..	..	..	..	.....	3,921	109	69	68	167	..
Mississippi.....	7	6	..	..	.....	665	.....	26	10	2	..
Louisiana.....	..	..	..	..	.....	.....	.....	.....	.....	.....	.....
Texas.....	..	..	..	10	.....	1,048	.....	.....	.....	.....	26
Arkansas.....	..	140	15	30	676	12,291	3,233	821	541	38	1
Tennessee.....	454	6	141	10	787	363,131	161,740	18,904	9,611	1,923	50
Kentucky.....	16,432	33,044	1,355	2,026	4,844	2,100,116	723,234	75,501	28,881	1,251	340
Ohio.....	100	..	50	..	3	446,932	.....	188,880	250,768	1,552	2,166
Michigan.....	..	..	..	..	.....	7,152	3,859	519	223	108	1,043
Indiana.....	..	..	..	..	1	584,469	73,112	36,888	153,159	887	959
Illinois.....	..	..	..	..	.....	160,063	32,636	10,787	11,202	47	436
Wisconsin.....	..	97	..	15	244	68,393	21,644	1,191	4,256	..	15
Minnesota.....	..	..	..	..	.....	.....	1,968	.....	73	..	..
Iowa.....	..	..	..	..	.....	62,660	28,888	1,959	6,130	246	217
Missouri.....	15,963	15,789	60	1,507	1,972	527,160	109,887	13,696	4,656	186	127
Kansas.....	..	44	..	..	.....	.....	13	.....	9	..	..
California.....	..	..	..	..	.....	.....	.....	.....	.....	.....	.....
Oregon.....	..	5	..	..	.....	640	50	.....	4	..	..
Washington.....	..	..	..	..	.....	.....	39	.....	.....	..	..
Utah.....	..	..	..	1	.....	550	4,197	5	145	..	1
New Mexico.....	..	..	..	..	.....	.....	.....	.....	.....	..	..
Nebraska.....	..	7	..	2	.....	.....	.....	.....	2	..	..
Dakota.....	..	..	..	..	.....	.....	.....	.....	.....	..	..

AGRICULTURAL STATISTICS—Continued.

STATES AND TERRITORIES.	Maple sugar, lbs.		Cane sugar, hhd. (1,000 lbs. each).		Molasses, gallons.*			Beeswax and honey, lbs.		Value of home-made manuf.		
	1850.	1860.	1850.	1860.	1850.		1860.	1850.	1860.	1850.	1860.	
					Cane and maple.	Cane and sorghum.						
Maine.....	93,542	306,742	..	..	3,167	....	....	189,618	8,769	314,685	\$513,599	\$490,787
N. H.....	1,298,863	2,255,012	..	..	9,811	....	....	117,140	4,986	125,142	898,455	251,013
Vermont.....	6,349,357	9,819,939	..	..	5,997	....	....	249,422	8,258	204,647	267,710	63,295
Mass.....	795,525	1,006,078	..	..	4,698	....	....	59,508	3,289	59,125	205,338	243,586
R. I.....	28	..	..	..	4	5	....	6,847	540	5,261	26,495	7,824
Conn.....	50,796	44,259	..	..	665	2,277	395	98,304	4,371	62,730	192,252	48,954
New York.....	10,857,484	10,816,458	..	..	56,539	181,856	265	1,755,880	121,019	2,369,751	1,280,338	717,865
New Jersey.....	2,197	3,455	..	..	954	8,124	360	156,694	8,180	185,925	112,781	27,888
Penn.....	2,326,525	2,768,965	..	..	50,652	127,455	9,605	839,509	52,570	1,402,128	749,132	544,732
Delaware.....	..	..	..	..	50	761	582	41,248	1,998	66,137	38,121	17,561
Maryland.....	47,740	68,281	..	..	1,430	2,449	862	74,802	6,960	193,354	111,828	67,003
D. Columbia.....	..	..	..	..	..	..	..	550	24	510	2,075	440
Virginia.....	1,227,665	937,643	..	..	40,822	100,189	221,017	880,767	94,861	1,480,811	2,156,312	1,575,885
N. Carolina.....	27,932	80,845	..	88	704	30,253	263,475	512,289	170,495	2,055,969	2,086,522	2,048,372
S. Carolina.....	200	205	671	198	15,904	15,144	51,041	216,281	40,479	526,077	909,525	815,117
Georgia.....	50	991	1,642	1,167	216,150	546,790	103,450	732,514	61,505	903,915	1,838,965	1,431,413
Florida.....	..	..	2,750	1,761	352,898	435,890	..	18,971	10,888	1,163,540	75,882	62,345
Alabama.....	643	543	8,242	108	83,428	81,694	67,172	897,021	158,018	1,189,078	1,934,120	1,920,115
Mississippi.....	..	99	888	244	18,818	21,734	8,207	397,460	40,449	595,859	1,164,020	1,318,426
Louisiana.....	255	..	226,001	297,816	10,931,177	14,601,627	..	96,701	4,748	90,770	139,232	508,124
Texas.....	..	69	7,351	590	441,918	392,337	115,051	850,825	26,885	550,708	206,984	496,169
Arkansas.....	9,330	3,097	..	..	18	115,673	..	192,338	50,797	802,748	638,217	928,481
Tennessee.....	158,557	117,359	248	..	7,233	301,076	485,828	1,036,572	104,286	1,494,680	3,137,790	3,166,185
Kentucky.....	437,405	380,941	254	..	30,079	139,036	365,861	1,158,019	68,340	1,768,692	2,459,128	2,065,575
Ohio.....	4,588,209	3,323,942	..	..	197,308	392,932	707,416	804,275	52,415	1,389,292	1,712,194	600,661
Michigan.....	2,439,794	2,988,018	..	..	19,523	384,521	266,509	859,232	41,972	728,900	840,947	148,181
Indiana.....	2,921,192	1,515,594	..	..	180,325	203,028	827,777	935,329	85,074	1,186,865	1,631,039	847,251
Illinois.....	248,904	181,751	..	..	8,354	21,428	797,096	869,444	56,874	1,333,250	1,153,902	938,515
Wisconsin.....	610,976	1,584,406	..	283	9,874	83,003	19,253	131,005	8,009	207,184	43,624	128,423
Minnesota.....	2,950	370,947	..	..	..	21,829	14,974	80	2,083	32,840	..	8,067
Iowa.....	78,407	243,951	..	..	8,162	97,751	1,998,474	821,711	32,502	919,750	221,292	314,466
Missouri.....	178,910	149,430	..	..	5,636	22,805	776,101	1,328,972	79,190	1,585,933	1,674,705	1,984,362
Kansas.....	..	1,548	..	..	..	2	73,482	..	467	14,942	..	15,871
California.....	..	..	..	..	..	..	100	..	570	2,370	7,060	263,674
Oregon.....	..	..	..	..	..	24	..	..	334	627	..	45,914
Washington.....	..	..	..	..	..	..	..	..	564	5,256	..	33,206
Utah.....	..	..	..	..	..	58	..	..	3	..	1,392	69,643
New Mexico.....	..	..	..	..	..	4,236	..	..	2	..	6,038	26,396
Nebraska.....	..	316	..	..	..	..	275	..	..	..	..	1,776
Dakota.....	..	..	..	..	..	..	20	..	..	..	..	..

TOTAL AGRICULTURAL PRODUCTIONS OF THE UNITED STATES DURING THE YEARS ENDING JUNE 1, 1850, AND JUNE 1, 1860.

PRODUCTIONS.	1850.	1860.	PRODUCTIONS.	1850.	1860.
Improved lands in farms, acres.....	113,032,614	163,261,389	Buckwheat, bushels.....	8,956,912	17,664,914
Unimproved land in farms, acres.....	180,528,800	246,508,244	Value of orchard products.....	\$7,723,186	\$19,753,361
Cash value in farms.....	\$3,271,575,426	\$6,650,872,507	Wine, gallons.....	221,249	1,860,066
Value of farming implements and machinery.....	\$151,587,638	\$247,027,496	Value of produce of market-gardens.....	\$5,280,080	\$15,541,027
Horses.....	4,336,719	6,115,458	Butter, lbs.....	313,345,306	460,509,534
Asses and mules.....	595,331	1,129,553	Cheese, lbs.....	105,835,898	105,873,135
Milch cows.....	6,385,094	8,728,562	Hay, tons.....	13,838,642	19,129,133
Working oxen.....	1,700,694	2,240,075	Clover seed, bushels.....	465,978	929,010
Other cattle.....	10,293,069	14,671,400	Other grass-seeds, bushels.....	416,831	900,356
Sheep.....	21,723,220	23,317,756	Hops, lbs.....	3,497,029	11,010,012
Swine.....	30,354,213	32,555,267	Dew-rotted hemp, tons.....	38,198	83,247
Value of live stock.....	\$544,180,516	\$1,107,490,216	Water-rotted hemp, tons.....	1,678	8,343
Value of animals slaughtered.....	\$111,703,142	\$212,871,653	Other prepared hemp, tons.....	..	17,800
Wheat, bushels.....	100,485,944	171,183,381	Flax, lbs.....	7,709,676	3,783,079
Rye, bushels.....	14,188,813	20,976,286	Flaxseed, bushels.....	562,812	611,927
Indian corn, bushels.....	592,071,104	890,451,707	Silk cocoons, lbs.....	10,843	6,562
Oats, bushels.....	146,584,179	172,554,688	Maple sugar, lbs.....	34,259,436	38,863,854
Rice, lbs.....	215,313,497	187,140,173	Cane sugar, hhd. of 1,000 lbs.....	237,133	302,205
Tobacco, lbs.....	199,752,655	429,390,771	Molasses, gallons.....	12,700,991	25,516,699
Ginned cotton, bales of 400 lbs. each.....	2,469,493	5,198,077	Maple molasses, gallons.....	..	1,944,594
Wool, lbs.....	52,516,959	60,511,343	Cane molasses, gallons.....	..	16,337,501
Peas and beans, bushels.....	9,219,901	15,188,013	Sorghum molasses, gallons.....	..	7,235,255
Irish potatoes, bushels.....	65,797,896	110,571,201	Beeswax and honey, lbs.....	14,853,790	26,386,855
Sweet potatoes, bushels.....	38,268,148	41,606,302	Beeswax, lbs.....	..	1,357,844
Barley, bushels.....	5,167,015	15,635,119	Honey, lbs.....	..	25,028,991
			Val. of home-made manufactures.....	\$27,493,644	\$94,353,232

\* Cane and maple molasses are returned together in the census of 1850, and separately in that of 1860. The product of Delaware and Missouri in 1860 was all cane molasses; of that of North Carolina, 13,484 gallons was cane, and 17,759 maple; of Mississippi, 8,345 cane; of Louisiana, 66,470 maple; of Texas, 8,600 maple; and of Tennessee, 6,754 maple. In all other cases the kind of molasses, with slight exceptions, corresponds with that of the sugar produced. The culture of sorghum has been introduced since 1850.

CONDENSED TABULAR STATEMENT OF THE AGGREGATE OF MANUFACTURES IN EACH STATE AND TERRITORY, 1860.

STATES AND TERRITORIES.	Number of establishments.	Capital.	Cost of raw material.	Male hands.	Female hands.	Cost of labor per annum.	Value of product.
Alabama.....	1,026	\$3,450,606	\$2,224,960	4,897	539	\$1,105,524	\$4,523,876
Arkansas.....	261	305,015	215,789	812	80	159,876	687,908
California.....	1,008	1,006,197	1,201,154	3,964	.....	3,717,180	12,662,522
Connecticut.....	3,787	25,375,648	28,608,971	24,248	16,438	12,435,984	47,114,585
Delaware.....	581	2,975,945	2,364,607	3,237	651	936,924	4,649,296
District of Columbia.....	408	1,001,575	1,405,871	2,084	536	737,534	2,690,258
Florida.....	103	547,000	220,611	876	115	199,452	663,335
Georgia.....	1,522	5,456,488	3,404,917	6,650	1,718	1,709,664	7,082,075
Illinois.....	3,162	6,217,765	8,959,827	11,066	498	3,204,326	16,534,272
Indiana.....	4,292	7,750,402	10,369,700	13,748	692	3,723,944	13,725,423
Iowa.....	522	1,222,875	2,356,881	1,037	20	473,016	8,551,738
Kentucky.....	3,609	11,810,462	12,165,075	19,576	1,900	5,106,043	21,710,212
Louisiana.....	1,006	5,082,424	2,459,508	5,458	759	2,068,923	6,779,417
Maine.....	3,274	14,699,152	18,558,144	21,858	6,167	7,485,533	24,661,067
Maryland.....	3,735	14,924,450	17,690,886	22,729	7,423	7,403,523	33,048,822
Massachusetts.....	8,852	83,940,222	85,856,771	107,734	69,677	41,954,736	157,743,994
Michigan.....	2,033	6,533,620	6,186,823	8,990	354	2,717,124	11,169,002
Mississippi.....	247	1,815,820	1,275,771	8,046	108	2,717,523	3,912,068
Missouri.....	2,223	3,576,607	12,793,851	14,880	923	4,692,648	24,324,418
New Hampshire.....	3,211	18,242,114	12,745,466	14,108	12,939	6,128,876	28,164,508
New Jersey.....	4,207	22,298,258	22,011,871	29,063	8,763	9,264,740	39,351,256
New York.....	23,553	99,904,405	124,655,674	147,737	51,619	49,131,000	237,597,249
North Carolina.....	2,623	7,456,860	4,602,501	12,473	2,123	2,333,456	9,111,050
Ohio.....	10,222	22,019,588	34,673,019	47,054	4,437	13,467,156	62,692,279
Pennsylvania.....	21,605	94,473,810	87,206,877	124,633	32,078	37,162,232	155,044,910
Rhode Island.....	864	12,938,676	13,186,708	12,923	8,044	5,047,080	22,117,683
South Carolina.....	1,420	6,058,285	2,787,584	5,992	1,074	1,137,712	7,045,477
Tennessee.....	2,287	6,527,739	5,166,826	11,030	959	2,247,422	9,723,603
Texas.....	809	539,220	394,642	1,042	24	322,363	1,163,533
Vermont.....	1,249	5,001,377	4,173,523	6,594	1,551	2,202,243	8,570,920
Virginia.....	4,740	13,109,143	13,101,131	25,790	3,320	5,434,478	29,602,507
Wisconsin.....	1,222	3,323,143	5,414,981	5,798	291	1,712,426	9,223,068
Minnesota.....	5	94,000	24,300	68	.....	13,540	58,300
New Mexico.....	23	63,300	110,220	81	.....	20,773	249,010
Oregon.....	52	843,600	302,560	235	.....	333,620	2,232,640
Utah.....	14	44,400	337,331	51	.....	9,294	291,220
Aggregate.....	123,025	\$532,245,351	\$555,123,822	731,137	225,922	\$226,755,464	\$1,019,104,616

STATEMENT OF THE LEADING MANUFACTURES, AND THE VALUE OF PRODUCT OF EACH IN THE YEARS ENDING JUNE 1, 1850, AND JUNE 1, 1860.

Number.	LEADING MANUFACTURES.	Value of product in 1850.	Value of product in round numbers, 1860.
1	Flour and meal.....	\$134,056,736	\$224,000,000
2	Cotton goods.....	63,501,637	115,000,000
3	Lumber.....	53,520,966	96,000,000
4	Boots and shoes.....	53,967,408	90,000,000
5	Leather, including morocco and patent leather.....	37,702,823	72,000,000
6	Clothing.....	43,311,709	70,000,000
7	Woolen goods.....	39,343,567	69,000,000
8	Machinery, steam engines, &c.....	27,928,344	47,000,000
9	Printing: book, job, and newspaper.....	11,536,549	42,000,000
10	Sugar refining.....	9,698,809	38,500,000
11	Iron founding.....	90,111,517	28,500,000
12	Spirituous liquors.....	15,770,240	25,000,000
13	Cabinet furniture.....	17,663,064	24,000,000
14	Bar and other rolled iron.....	4,928,061	22,000,000
15	Pig iron.....	22,424,608	19,500,000
16	Malt liquors.....	3,723,563	18,000,000
17	Agricultural implements.....	6,342,611	17,000,000
18	Paper.....	10,137,177	17,500,000
19	Soap and candles.....	10,199,730	17,000,000

## APPROXIMATE STATISTICS OF THE PRODUCTS OF INDUSTRY FOR THE YEAR ENDING JUNE 1, 1860

STATES AND TERRITORIES.	Number of establishments.	Capital invested, in real and personal estate, in the business.	Value of raw material used, including fuel.	Average number of hands employed.		Value of annual product.
				Male.	Female.	
Maine.....	3,582	\$22,000,000	\$20,861,452	25,000	14,710	\$26,075,423
New Hampshire.....	2,582	25,900,000	24,400,000	19,200	16,900	45,500,000
Vermont.....	1,501	9,500,000	8,110,000	8,940	1,860	16,000,000
Massachusetts.....	7,766	133,000,000	141,000,000	148,800	65,800	266,000,000
Rhode Island.....	1,160	23,300,000	23,400,000	21,200	12,000	47,500,000
Connecticut.....	2,923	45,720,000	40,140,000	44,160	21,620	83,000,000
Total in New England States.....	19,514	259,420,000	257,911,452	267,300	135,390	494,075,423
New York.....	23,236	175,449,206	209,899,890	174,059	47,422	379,623,560
Pennsylvania.....	21,100	189,000,000	145,300,000	185,141	38,000	255,500,000
New Jersey.....	4,060	40,000,000	42,600,000	114,660	18,060	81,000,000
Delaware.....	564	5,860,000	5,375,000	5,332	860	9,920,000
Maryland.....	2,980	51,800,000	21,900,000	20,500	20,100	42,576,000
District of Columbia.....	424	2,650,000	2,501,000	2,556	387	5,512,000
Total in Middle States.....	52,364	464,259,206	427,875,890	502,548	119,829	804,131,560
Ohio.....	10,710	58,000,000	70,000,000	69,800	11,400	125,000,000
Indiana.....	5,120	13,875,000	27,360,000	20,600	710	43,250,000
Michigan.....	2,530	24,000,000	19,000,000	22,860	1,260	35,200,000
Illinois.....	4,100	27,700,000	33,800,000	23,500	870	56,750,000
Wisconsin.....	3,120	16,580,000	17,250,000	16,320	770	28,500,000
Minnesota.....	565	2,400,000	2,060,000	2,215	15	3,600,000
Iowa.....	1,790	7,500,000	8,500,000	6,475	102	14,900,000
Missouri.....	2,800	20,500,000	24,000,000	20,130	1,200	43,500,000
Kentucky.....	3,160	20,000,000	21,380,000	20,580	1,460	36,330,000
Kansas.....	299	1,063,000	669,269	1,719	.....	2,800,000
Nebraska.....	107	271,475	238,225	381	8	531,942
Total in Western States.....	34,301	196,889,475	224,257,494	204,530	17,795	390,411,942
Virginia.....	4,890	26,640,000	30,880,000	33,050	8,540	51,300,000
North Carolina.....	2,790	9,310,000	9,560,000	11,760	2,130	14,450,000
South Carolina.....	1,050	5,610,000	3,620,000	6,000	800	6,800,000
Georgia.....	1,724	11,160,000	10,000,000	9,910	2,180	13,700,000
Florida.....	180	6,675,000	965,000	2,310	170	2,700,000
Alabama.....	1,117	8,260,000	4,400,000	6,620	1,140	9,400,000
Louisiana.....	1,710	7,110,000	7,380,000	7,610	80	5,500,000
Texas.....	910	3,850,000	2,770,000	3,360	110	6,250,000
Mississippi.....	860	3,740,000	2,460,000	4,540	150	6,000,000
Arkansas.....	375	1,040,000	909,000	1,520	35	2,150,000
Tennessee.....	2,420	17,270,000	9,365,000	11,960	1,135	17,100,000
Total in Southern States.....	18,026	100,665,000	82,609,000	98,640	11,470	145,350,000
Utah.....	152	412,126	393,528	248	9	823,000
California.....	3,505	23,682,593	16,568,636	23,803	463	59,500,000
Oregon.....	300	1,293,000	1,452,000	986	10	3,188,000
Washington.....	52	1,296,700	505,000	896	4	1,405,000
New Mexico.....	86	2,081,900	432,000	949	30	1,165,000
Total in Pacific States.....	4,095	28,766,319	19,346,164	26,982	516	66,081,000
Aggregate in United States.....	128,300	\$1,050,000,000	\$1,012,000,000	1,100,000	285,000	\$1,900,000,000

Such are the important facts furnished by the census of 1860, so far as they have been compiled. The political action of the United States in 1862 is the next topic to be considered.

Perhaps a brief summary of the opinions which had existed, the declarations which had been made, and the measures which had been adopted up to the close of 1861, will greatly assist in forming a correct view of the course of the Government in 1862, relative to the war, which was the great and absorbing subject of its action. The measures and disputes which resulted in war, all had reference to the existence of slavery in the Southern States. The Federal Government was conducted by those who were mixed up in these measures and disputes on the one side, and the Confederate Government by those involved in them on the other. The opinion entertained by Southern statesmen previous to the difficulties was that the Constitution of the United States pro-

tected the institution of slavery in the States, in so far as it withheld from the Government all power to interfere with the institutions of the States, as it required the Government to restore fugitives, as it gave a representation in Congress based upon their numbers, and as all direct taxes were to be estimated on a basis including this population.

Those known as radical abolitionists in the Northern States held the same opinion relative to the Constitution of the United States, and for this reason they denounced it as "a covenant with death and a league with hell." In their view disunion immediate and complete was the only feasible means by which to be released from its obligations. Those known as anti-slavery men had a distinct political organization, and took a position in the rear of the former. They held a similar opinion relative to the powers of the Federal Government over the institutions of the States, but de-

voted their efforts to defeat the operations of the law for the recovery of fugitives, to aid the slave in escaping from his servitude, to thwart on every occasion, if possible, all measures tending to promote the interests of slaveholders, and to persuade persons tenderly conscientious, that slavery was a sin which it was their duty to exterminate, and that the black man was the equal of the white man. The remainder of the people held the same opinion on the powers of the Federal Government over the institutions of the States. Indeed, it may be said there was not a dissentient opinion on that subject. But while the great mass of the people in the Northern States held these views they also considered that slavery was an institution abolished as profitless at the North, and, therefore, one in which they had no concern.

The thoughtful reader will see that here were the seeds of a dissolution of the Union of the States. So long as the persons of anti-slavery or abolition views were few and insignificant, they remained in obscurity, but if the hour should ever come in which they should hold the control of the Federal Government, it would involve a concession on their part, or on that of the slaveholders, or a rupture. There was nothing to encourage the patriotic citizen to hope that concessions would be made if this hour of fate should ever come. The anti-slavery men of the Northern States and the slaveholding citizens of the Southern States quickly grew to be antagonists, and their differences and disputes were conducted with the most bitter and vindictive denunciations to be found in human language. On the floor of Congress members from the Northern States, holding high positions for intelligence and piety, denounced the slaveholding citizens of the Southern States as "bartering their own children," as "dealing in the image of God," as "buying and selling the souls of men," as "making merchandise of the Holy Ghost."\* The reply to such expressions was "contemptible fanatic," &c., &c.

Meanwhile the anti-slavery sentiment grew apace, and there became enough who held those views to control State elections, by acting as a third party, and thus in one instance to control the vote of a great State at a Presidential election, which was thereby decided. The progress of these views now was more rapid; slavery was attacked in both Senate and House of Congress at every assailable point. To satisfy the scruples of the citizen who knew his duty of non-interference under the Constitution, and the stings of a conscience called to act under a belief that citizenship with a slaveholder was sin, the principle of a "higher law" was proclaimed which relieved the conscience from the obligations of the Federal Constitution. The progress of anti-slavery views now was rapid. One of the great political parties

of the country was demoralized and broken up, and an anti-slavery candidate for the Presidency brought forward who carried every free State but four, and thus was almost successful. Four years of bitter anti-slavery contests ensued in which the object was to defeat the extension of slavery to any Territory by preventing the creation of any authority for its existence there. This was to be done by a direct prohibition by Congress, as some urged, or by absolute non-interference by Congress, but by the decision of the settlers. Meantime the slaveholders were told that the contest was "irrepressible," that it would go on, from the very nature of the question, until all the States became free, or all became slaveholding. At length, by the Presidential election of 1860, the administration of the Federal Government was put into the hands of the anti-slavery party. Such had been the bitterness of the contest that seven of the extreme Southern States took steps immediately to withdraw from the Union. The reason on which they attempted to justify their acts was that, in their opinion, it was the determined purpose of the Republican or anti-slavery party to so interfere with their domestic institutions as to render it unsafe for them longer to continue in the Union. (*See ANNUAL CYCLOPEDIA, 1861, CONGRESS, U. S.*) Such, however, was the attachment of the mass of the people in those seven states to the Union, and such their indifference to these movements—that if the Republican President and party had not entertained such designs of interference, and had boldly, promptly, and fully denied it, the people would have been satisfied and secession would have been a failure from the start. On the other hand, this great party after a struggle of years had won the rightful possession to the sceptre of the nation, and were indignant at these proceedings. They preserved a moody silence, and defied the consequences. But it was the design of a portion of them to interfere with the institution of slavery and destroy it if possible. The radical abolitionists of the party preferred disunion to a longer continuance under the Constitution as it was and the Union as it had been. The anti-slavery men of the party hoped for some way to be opened to remove this institution which they regarded as a national sin. Others were determined if possible to divorce the Government from all connection with the institution, and secure "its administration on the side of freedom." Notwithstanding these were the views of considerable portions of the friends of the incoming administration, yet the great mass of them had the highest attachment to the Constitution and the Union. President Lincoln, representing their views, in his inaugural said—"the property and peace of no section are to be in no wise endangered by the now incoming Administration." In all his messages of the year 1861—in the despatches of the State Department, and in the resolutions of Congress at the extra session,

\* See speeches of Horace Mann, successor to Ex-President John Quincy Adams, and others.



the maintenance of the Constitution and the preservation of the Union, with all the dignity, equality, and rights of the several States unimpaired, was declared to be the only object of the Government. In addition a proclamation by Gen. Fremont of emancipation to slaves in Missouri was countermanded by the President; and that portion of the report of the Secretary of War, Cameron, at the commencement of the session of Congress in Dec. 1861, which contained the following among other remarks, was suppressed: "If it shall be found that the men who have been held by the rebels as slaves are capable of bearing arms, and performing efficient military service, it is the right and may become the duty of this Government to arm and equip them, and to employ their services against the rebels, under proper military regulation, discipline, and command."

Such was the declared position of the Government at the close of 1861, and it was understood to be its policy not to interfere with the institutions of the States, or their domestic and local policy. These views received the approval of the great mass of the people in the States remaining in the Union, and they were producing a paralyzing effect upon the hostile elements in the seceded States. No evidence to sustain the charges which had led to secession was to be found in the acts of the Government, nor were there any indications of a purpose to approve of or adopt any distinctive anti-slavery measures in the conduct of public affairs. It may have been true that the sudden and unusual state of affairs into which the Government was thrown, demanded all its energies for the emergency, and no opportunity was given to introduce or develop any particular policy beyond its reference to present events. In the single instance of fugitives or "contrabands" as they were called, the whole action of the Government, however, was in favor of the freedom of the slaves.

At this time the first regular session of the 37th Congress commenced, Dec. 1861, and it soon appeared to differ widely from the Government. The position was assumed by the majority that slavery was the cause of the war with all its evils, and therefore it was the duty of the Government in all its branches to strive to remove this cause. Measures were at once introduced to emancipate the slaves in the district of Columbia, to prohibit the existence of slavery in all the Territories, and to abolish slavery in the seceded States by confiscation; also to remove every obstacle to the successful escape of the slave from his master in those States (*see* CONGRESS, U. S.) The introduction and discussion of these measures indicated that the legislative branch of the Government was rapidly adopting anti-slavery views. The difficulties presented by the Constitution to some of the measures proposed were avoided on the ground that under the "war power," as it was called, Congress could adopt any measures necessary to sustain the existence of the Govern-

ment. The way was thus cleared for the enforcement of the most thorough anti-slavery measures, if the administrative officers of the Government came up to the necessary point for their execution. Those who had struggled for so many years under obloquy and reproach, as the friends of the slave, to whom it was necessary to give freedom, whether in the Divine order of events or not, now conceived that the day of universal emancipation through their efforts would soon dawn.

On the 6th of March President Lincoln sent a message to Congress recommending an expression by that body, that the United States ought to cooperate with any State which might adopt gradual emancipation by giving them pecuniary aid. (*See* PUBLIC DOCUMENTS, page 720). This was a great step. It was a direct and positive interference with the domestic institutions of the States. It was justified on the ground, that to deprive the leaders of secession of the hope that they would ultimately be joined by the border slave States would end the contest. It admitted the absolute right of the States to control their domestic institutions; it admitted the property of the master in the slave, but it was a preliminary step to get rid of the institution. In Congress even those who had heretofore denounced such suggestions on the ground that the "body and soul" of man could not be made the subject of pecuniary purchase or compensation, except at the sacrifice of admitting the rightfulness of the slaveowner's "claim," approved of the measure and suggested "the deportation of the institution over a bridge of gold." On the 10th of April the following resolution having passed Congress was approved:

*Be it resolved by the Senate and House of Representatives of the United States of America in Congress assembled, That the United States ought to co-operate with any State which may adopt gradual abolition of slavery, giving to such State pecuniary aid, to be used by such State in its discretion, to compensate for the inconveniences, public and private, produced by such a change of system.*

*Approved, April 10, 1862.*

Among the people, those classed as extreme conservatives said, with regard to the proposition, "the intervention which it calls for is a violation of all the pledges of the previous year, and its influence must be to undo the good effected by the few conservative measures of that year." On the other hand, those of extreme anti-slavery views objected to the measure, as it offered a bounty to all the States that were in Confederate secession as much as to any so called loyal slave States, which could not be done with any sort of propriety, justice, or consistency. It held out no inducement for immediate emancipation, whereas slavery ought not to exist for one moment, and special inducements ought to be held out for its instant abolition, as against a lingering process. Ethically and pecuniarily immediate emancipation was better for all parties; and the President was culpable for keeping up the old delusion

of "gradualism." Their views of the position of affairs were thus emphatically expressed:

The President, as well as Congress, in consequence of this slaveholding rebellion, and the dire extremity to which it has brought the nation, has now the constitutional right, power, and opportunity to "proclaim liberty throughout all the land to all the inhabitants thereof;" and neither the President nor Congress must be allowed to evade this solemn duty by any dodge of this kind. "Now is the accepted time;" and now let it be "the day of salvation." Multitudes of petitions from all the free States, signed by tens of thousands of estimable citizens, are before Congress, asking for the immediate abolition of slavery under the war power; and are these to be satisfied by proposing such a will-o'-the-wisp as a substitute? Why wait for the dealers in human flesh to determine when they will deem it advisable to cease from their villainy as a matter of pecuniary advantage and cunning speculation with the Government, when the Government is clothed with the constitutional power to dispose of the whole matter at once, without any huckstering or delay? "Let justice be done; though the heavens fall." President Lincoln, delay not at your peril! "Execute judgment in the morning—break every yoke—let the oppressed go free."

In a word, the proclamation was regarded by them as a "dodge" which must not be allowed to succeed.

The views of the President respecting the importance of emancipation with compensation are stated more fully and earnestly in a proclamation issued on the 19th of May, countermanding an emancipation order of General Hunter. (See PUBLIC DOCUMENTS.) He said:

"The resolution was adopted by large majorities in both branches of Congress, and now stands an authentic, definite, and solemn proposal of the nation to the States and people most interested in the subject matter. To the people of these States now I mostly appeal. I do not argue—I beseech you to make the arguments for yourselves. You cannot, if you would, be blind to the signs of the times. I beg of you a calm and enlarged consideration of them, ranging, if it may be, far above partisan and personal politics.

"This proposal makes common cause for a common object, casting no reproaches upon any. It acts not the Pharisee. The change it contemplates would come gently as the dews of Heaven, not rending or wrecking anything. Will you not embrace it? So much good has not been done by one effort in all past time as, in the Providence of God, it is now your high privilege to do. May the vast future not have to lament that you have neglected it."

The measure had frequently been suggested by public men before, but not in an official form.

On the 16th of April the President approved of the bill for the emancipation of the slaves in the District of Columbia, with compensation to the owners. At the same time he sent a message to Congress stating the fact, and adding:

"I have never doubted the constitutional authority of Congress to abolish slavery in the District, and I have ever desired to see the national capital freed from the institution in some satisfactory way. Hence there has never been, in my mind, any question upon the subject, except those of expediency, arising in view of all the circumstances. If there be matters within and about this act which might have taken the course or shape more satisfactory to my judgment, I do not attempt to specify them. I am gratified that the two principles of compensation and colonization are both recognized and practically applied in the act."

On the 9th of May Gen. Hunter, in the department of South Carolina, issued an order, stating that the States of South Carolina, Georgia, and Florida were declared, on the 25th of April preceding, to be under martial law. He then added: "Slavery and martial law in a free country are altogether incompatible. The persons in these States heretofore held as slaves are, therefore, declared forever free." The President immediately afterward issued his proclamation, as above stated, disavowing, on the part of the Government, any previous knowledge of this proceeding, and denying the authority of any general to take such a step, also stating that it was a question reserved to himself for decision.

This measure of Gen. Hunter served as a new occasion to call forth the sentiments of the people relative to the policy of the Government. In the course which it had thus far pursued, especially in countermanding this act, it was regarded as proceeding in the manner prescribed by the Constitution and the law. The act itself was almost universally regretted or condemned. It was apprehended that it would tend to alienate the sympathies of Unionists residing in these States, and in the other slaveholding States, and that it would be used by the Confederates to add fresh fuel to the flames by which the hearts of the Southern people had been fired, and to extinguish which more blood must necessarily flow. By some it was condemned on the great principle that each State had exclusive jurisdiction of the subject, as it had of all its internal or domestic affairs; some opposed it because of its manifest injustice in punishing, without discrimination, those who were Unionists as well as those who were disunionists; others were against it because of its direct and violent antagonism to the often declared policy of the Administration, viz., so to conduct the war as not to render the reconstruction of the Union impossible.

Emancipation with compensation still continued to be the favorite measure of the President, and, in pursuance of that object, he specially invited the Representatives and Senators from the border slaveholding States to meet him in conference on the 12th of July. On that occasion he urged, as motives for the States which they represented to resolve upon such a measure, that it would divest the Confederate States of all hope that they would ultimately join the Confederacy; the incidents of the war might extinguish the institution in their States without compensation; such a step would also shorten the war and save the money otherwise expended. He said: "How much better for you, as seller, and the nation, as buyer, to sell out and buy out that without which the war could never have been, than to sink both the thing to be sold and the price of it in cutting one another's throats!" Mr. Lincoln then appealed to them with personal considerations, representing himself under a

constraint, from which he could escape by their approval of emancipation in this form. He thus stated it :

"I am pressed with a difficulty not yet mentioned—one which threatens division among those who, united, are none too strong. An instance of it is known to you. Gen. Hunter is an honest man. He was, and I hope still is, my friend. I valued him none the less for his agreeing with me in the general wish that all men everywhere could be free. He proclaimed all men free within certain States, and I repudiated the proclamation. He expected more good and less harm from the measure than I could believe would follow. Yet, in repudiating it, I gave dissatisfaction, if not offence, to many whose support the country cannot afford to lose. And this is not the end of it. The pressure in this direction is still upon me, and is increasing. By conceding what I now ask you can relieve me, and, much more, can relieve the country in this important point."

The remarks of the President were brought to a close with appeals, extremely urgent and almost pathetic, to the border State members, to induce them to act upon the measure. Thus :

"Before leaving the capitol, consider and discuss it among yourselves. You are patriots and statesmen, and as such I pray you consider this proposition, and, at the least, commend it to the consideration of your States and people. As you would perpetuate popular government for the best people in the world, I beseech you that you do in no wise omit this. Our common country is in great peril, demanding the loftiest views and boldest action to bring a speedy relief. Once relieved, its form of Government is saved to the world; its beloved history and cherished memories are vindicated, and its happy future fully assured and rendered inconceivably grand. To you, more than to any others, the privilege is given to assure that happiness and swell that grandeur, and to link your own names therewith forever."

The delegation, which consisted of Senators and Representatives from Maryland, Western Virginia, Kentucky, and Missouri, retired to consult upon the proposition and prepare their answer to the President. Two replies, a majority and a minority, were made. The majority stated their reasons for declining to support the measure. The minority promised to recommend the measure to the consideration of the people. (*See PUBLIC DOCUMENTS.*) Replies were also made by individuals.

The answer of the majority contains also a statement of the posture of public affairs at the time and of the conduct of the war, which expressed the views of a large mass of the citizens of the Northern States. It was in these words :

The rebellion derives its strength from the union of all classes in the insurgent States; and while that union lasts the war will never end until they are utterly exhausted. We know that at the inception of these troubles Southern society was divided, and that a large portion, perhaps a majority, were opposed to secession. Now the great mass of Southern people are united. To discover why they are so we must glance at Southern society, and notice the classes into which it has been divided, and which still distinguish it. They are in arms, but not for the same objects; they are moved to a common end, but by different and even inconsistent reasons. The leaders, which word comprehends those who were previously known as the State Rights party, and which party is much the lesser class, seek to break down national independence and set up State domination. With them it is a war against nationality. The

other class is fighting, as it supposes, to maintain and preserve its rights of property and domestic safety, which it has been made to believe are assailed by this Government. This latter class are not disunionists *per se*; they are so only because they have been made to believe that this Administration is inimical to their rights, and is making war on their domestic institutions. As long as these two classes act together they will never assent to a peace. The policy, then, to be pursued is obvious. The former class will never be reconciled, but the latter may be. Remove their apprehensions: satisfy them that no harm is intended to them and their institutions; that this Government is not making war on their rights of property, but is simply defending its legitimate authority, and they will gladly return to their allegiance as soon as the pressure of military dominion imposed by the Confederate authority is removed from them.

Twelve months ago both Houses of Congress, adopting the spirit of your Message, then but recently sent in, declared with singular unanimity the objects of the war, and the country instantly bounded to your side to assist you in carrying it on. If the spirit of that resolution had been adhered to, we are confident that we should before now have seen the end of this deplorable conflict. But what have we seen? In both Houses of Congress we have heard doctrines subversive of the principles of the Constitution, and seen measure after measure founded in substance on those doctrines proposed and carried through, which can have no other effect than to distract and divide loyal men, and exasperate and drive still further from us and their duty the people of the rebellious States. Military officers, following these bad examples, have stepped beyond the just limits of their authority in the same direction, until in several instances you have felt the necessity of interfering to arrest them. And even the passage of the resolution to which you refer has been ostentatiously proclaimed as the triumph of a principle which the people of the Southern States regard as ruinous to them. The effect of these measures was foretold, and may now be seen in the indurated state of Southern feeling.

To these causes, Mr. President, and not to our omission to vote for the resolution recommended by you, we solemnly believe we are to attribute the terrible earnestness of those in arms against the Government, and the continuance of the war. Nor do we (permit us to say, Mr. President, with all respect for you) agree that the institution of slavery is "the lever of their power," but we are of the opinion that "the lever of their power" is the apprehension that the powers of a common Government, created for common and equal protection to the interests of all, will be wielded against the institutions of the Southern States.

It will be seen by this statement that in the opinion of its authors the anti-slavery character of the Government was the cause of the bitterness of the war, and that the indications of an extreme anti-slavery policy served to divide the Northern people and exasperate the Southern. This, therefore, was the charge made against the Government at the time: that by an extreme anti-slavery course it would violate the Constitution and ultimately destroy, instead of restoring, the Union, which was the desire of all. There was truth in this charge. The expression of Congress at the session of July, 1861, had passed away, and the Government was advancing step by step to a proclamation of emancipation. Still an apparent or real reluctance thus to advance was manifest on the part of the President. His own declarations show that a most extreme pressure was put upon him to cause the use of his power for the destruction of slavery. The extreme anti-

slavery men were resolved to control the Government and wield it to their purposes, and by them the pressure was made to achieve their object. The answer of the delegates presents the various views relative to this point. They say :

How can we, by conceding what you now ask, relieve you and the country from the increasing pressure to which you refer? We will not allow ourselves to think that the proposition is, that we consent to give up slavery, to the end that the Hunter proclamation may be let loose on the Southern people, for it is too well known that we would not be parties to any such measure, and we have too much respect for you to imagine you would propose it. Can it mean that by sacrificing our interest in slavery we appease the spirit that controls that pressure, cause it to be withdrawn, and rid the country of the pestilent agitation of the slavery question? We are forbidden so to think, for that spirit would not be satisfied with the liberation of seven hundred thousand slaves, and cease its agitation, while three millions remain in bondage. Can it mean that by abandoning slavery in our States, we are removing the pressure from you and the country, by preparing for a separation on the line of the cotton States? We are forbidden so to think, because it is known that we are, and we believe that you are, unalterably opposed to any division at all. We would prefer to think that you desire this concession as a pledge of our support, and thus enable you to withstand a pressure which weighs heavily on you and the country. Mr. President, no such sacrifice is necessary to secure our support. Confine yourself to your constitutional authority; confine your subordinates within the same limits; conduct this war solely for the purpose of restoring the Constitution to its legitimate authority; concede to each State and its loyal citizens their just rights, and we are wedded to you by indissoluble ties.

Such were the views entertained of the policy of the Government by those who sustained it in the conduct of the war, but who were opposed to its political and anti-slavery principles. (See PUBLIC DOCUMENTS.)

This measure of emancipation with compensation soon proved a failure. Kentucky refused to act upon it. Maryland gave it no heed. Missouri was disposed to adopt it, but Congress expired without making any appropriation for the purpose. The next Congress will be less disposed to approve it than the last, as many of the States have protested against being taxed for any such purpose.

Bills were passed by Congress and approved by the Executive to open diplomatic relations with Hayti and Liberia. All the other measures of the same character at this session were likewise approved. At the same time military governors had been appointed in North Carolina, Tennessee, and Louisiana, on the principle that the State still lived and was a part of the Union, while some of its citizens were in a condition of hostility to the Federal Government. It was the duty of the governors to protect those loyal to the Constitution, who were considered as composing the State.

Near the 1st of July the following singular method was adopted to furnish the Government with new levies of troops. A letter was drawn up by the Governor of New York, with the concurrence of one or two others, and copies

sent to all the governors of the Federal States for their signatures. It was addressed to the President, and suggested that he had better call more troops into the field. The President replied, saying that he thought so too. The correspondence was as follows:

*To the President:* The undersigned, governors of States of the Union, impressed with the belief that the citizens of the States which they respectively represent are of one accord in the hearty desire that the recent successes of the Federal arms may be followed up by measures which must ensure the speedy restoration of the Union, and believing that in view of the important military movements now in progress, and the reduced condition of our effective forces in the field, resulting from the usual and unavoidable casualties of the service, that the time has arrived for prompt and vigorous measures to be adopted by the people in support of the great interests committed to your charge, we respectfully request, if it meets with your entire approval, that you at once call upon the several States for such number of men as may be required to fill up all the military organizations now in the field, and add to the armies heretofore organized such additional number of men as may, in your judgment, be necessary to garrison and hold all the numerous cities and military positions that have been captured by our armies, and to speedily crush the rebellion that still exists in several of the Southern States, thus practically restoring to the civilized world our great and good Government. All believe that the decisive moment is near at hand, and to that end the people of the United States are desirous to aid promptly in furnishing all reinforcements that you may deem needful to sustain our Government.

- ISRAEL WASHBURN, Jr., Gov. of Maine.
- N. S. BERRY, Gov. of New Hampshire.
- FREDERICK HOLBROOK, Gov. of Vermont.
- WM. A. BUCKINGHAM, Gov. of Connecticut.
- E. D. MORGAN, Gov. of New York.
- CHAS. S. OLDEN, Gov. of New Jersey.
- A. G. CURTIN, Gov. of Pennsylvania.
- A. W. BRADFORD, Gov. of Maryland.
- F. H. PIERPONT, Gov. of Virginia.
- AUSTIN BLAIR, Gov. of Michigan.
- J. B. TEMPLE, Pres. Mil. Board of Kentucky.
- ANDREW JOHNSON, Gov. of Tennessee.
- H. R. GAMBLE, Gov. of Missouri.
- C. P. MORTON, Gov. of Indiana.
- DAVID TOD, Gov. of Ohio.
- ALEXANDER RAMSEY, Gov. of Minnesota.
- RICHARD YATES, Gov. of Illinois.
- EDWARD SALOMON, Gov. of Wisconsin.

REPLY OF THE PRESIDENT.

EXECUTIVE MANSION, WASHINGTON, July 1.—*Gentlemen:* Fully concurring in the wisdom of the views expressed to me in so patriotic a manner by you in the communication of the 28th day of June, I have decided to call into the service an additional force of three hundred thousand men. I suggest and recommend that the troops should be chiefly of infantry. The quota of your State would be ———. I trust that they may be enrolled without delay, so as to bring this unnecessary and injurious civil war to a speedy and satisfactory conclusion. An order fixing the quota of the respective States will be issued by the War Department to-morrow.

(Signed) ABRAHAM LINCOLN.

This was the first call for three hundred thousand men.

In August charges were made against the President in the name of "twenty millions of people," in the most radical anti-slavery press, stating "that a great proportion of those who triumphed in his election are sorely disappointed and deeply pained by the policy he seems

to be pursuing with regard to the slaves of the rebels." "You are strangely and disastrously remiss in the discharge of your official and imperative duty with regard to the emancipation provisions of the new confiscation act." It was further added:

We complain that the Union cause has suffered, and is now suffering immensely, from mistaken deference to rebel slavery. Had you, sir, in your inaugural address, unmistakably given notice that, in case the rebellion already commenced were persisted in, and your efforts to preserve the Union and enforce the laws should be resisted by armed force, you would recognize no loyal person as rightfully held in slavery by a traitor, we believe the rebellion would therein have received a staggering if not fatal blow.

President Lincoln took notice of these charges, and replied by explaining the policy he was pursuing in these words:

As to the policy I "seem to be pursuing," as you say, I have not meant to leave any one in doubt.

I would save the Union. I would save it the shortest way under the Constitution. The sooner the national authority can be restored the nearer the Union will be "the Union as it was." If there be those who would not save the Union unless they could at the same time save slavery, I do not agree with them. If there be those who would not save the Union unless they could at the same time destroy slavery, I do not agree with them. My paramount object in this struggle is to save the Union, and is not either to save or to destroy slavery. If I could save the Union without freeing any slave I would do it, and if I could save it by freeing all the slaves I would do it; and if I could save it by freeing some and leaving others alone, I would also do that. What I do about slavery and the colored race, I do because I believe it helps to save this Union; and what I forbear, I forbear because I do not believe it would help to save the Union. I shall do less whenever I shall believe what I am doing hurts the cause, and I shall do more whenever I shall believe doing more will help the cause. I shall try to correct errors when shown to be errors; and I shall adopt new views so fast as they shall appear to be true views.

I have here stated my purpose according to my view of official duty; and I intend no modification of my oft-expressed personal wish that all men everywhere could be free. Yours, A. LINCOLN.

This letter of the President, expressing a purpose to effect the restoration of the Union without regard to incidental consequences to the slaves, was in accordance with the sentiments of the great mass of the people in the Federal States, including a large portion of his own political party. It had the effect for the moment of reviving the confidence of that portion of the people not adherents to abolitionism as such, that in spite of the "pressure" the war would yet be conducted for the sole purpose of restoring the Union of the States. The anti-slavery men were hushed. Their bitter and unsparing denunciation of all Northern citizens who stood aloof, through patriotic or conscientious motives, from the strictly anti-slavery views and measures of the Government, as "secessionists" and "traitors," was silenced—only, however, to break out again with the renewed effort to give another turn to the screws under which the President was writhing. Nevertheless the education of the people up to emancipation was becoming more com-

plete every day. A second call for three hundred thousand men was made, but the enlistments were slow. Threats of draft and most liberal bounties were required. This reluctance among the people to enter the ranks of the army was ascribed to the policy of the Government in not adopting bold emancipation measures. It was declared by the advocates of such measures that the streets and byways would be crowded with volunteers to fight for the freedom of the "loyal blacks," and thrice three hundred thousand could be obtained easily for that object. Still the Federal Government kept aloof. It was now urged by the advocates of emancipation that slavery in the seceded States should be treated by the Government as a military question. It was contributing nearly all the subsistence by which the enemy in arms was supported; it built the greater part of their fortifications; it dug the greater number of trenches; it alone enabled nearly all the able-bodied whites to join the Confederate army, &c. The watchword now was "the abolition of slavery by the force of arms for the sake of the Union." Those who objected to such a measure as at least futile, if not likely to be disastrous to the cause of the country, were put to silence by epithets of "disunionists," "traitors," "Southern sympathizers," and threats of imprisonment by their fellow citizens as enemies in disguise. But the Government made no proclamation. As late as the 18th of September the President was visited by a deputation representing the Christians in the city of Chicago, Illinois, with a memorial requesting him to issue a proclamation of emancipation. The deputation presented the memorial with such reasons in its favor as occurred to their minds, to which Mr. Lincoln replied as follows:

The subject presented in the memorial is one upon which I have thought much for weeks past, and I may even say for months. I am approached with the most opposite opinions and advice, and that by religious men, who are equally certain that they represent the Divine will. I am sure that either the one or the other class is mistaken in that belief, and perhaps in some respect both. I hope it will not be irreverent for me to say that if it is probable that God would reveal his will to others, on a point so connected with my duty, it might be supposed he would reveal it directly to me; for, unless I am more deceived in myself than I often am, it is my earnest desire to know the will of Providence in this matter. And if I can learn what it is I will do it! These are not, however, the days of miracles, and I suppose it will be granted that I am not to expect a direct revelation. I must study the plain physical facts of the case, ascertain what is possible and learn what appears to be wise and right. The subject is difficult, and good men do not agree. But we will talk over the merits of the case.

What good would a proclamation of emancipation from me do, especially as we are now situated? I do not want to issue a document that the whole world will see must necessarily be inoperative, like the Pope's bull against the comet! Would my word free the slaves, when I cannot even enforce the Constitution in the rebel States? Is there a single court, or magistrate, or individual that would be influenced by it there? And what reason is there to think it would have any greater effect upon the slaves than the late law of Congress, which I approved, and which offers

protection and freedom to the slaves of rebel masters who come within our lines? Yet I cannot learn that that law has caused a single slave to come over to us. And suppose they could be induced by a proclamation of freedom from me to throw themselves upon us, what should we do with them? How can we feed and care for such a multitude? Gen. Butler wrote me a few days since that he was issuing more rations to the slaves who have rushed to him than to all the white troops under his command. They eat, and that is all; though it is true Gen. Butler is feeding the whites also by the thousand; for it nearly amounts to a famine there. If, now, the pressure of the war should call off our forces from New Orleans to defend some other point, what is to prevent the masters from reducing the blacks to slavery again; for I am told that whenever the rebels take any black prisoners, free or slave, they immediately auction them off! They did so with those they took from a boat that was aground in the Tennessee river a few days ago. And then I am very ungenerously attacked for it! For instance, when, after the late battles at and near Bull Run, an expedition went out from Washington under a flag of truce to bury the dead and bring in the wounded, and the rebels seized the blacks who went along to help and sent them into slavery, Horace Greeley said in his paper that the Government would probably do nothing about it. What could I do!

Now, then, tell me, if you please, what possible result of good would follow the issuing of such a proclamation as you desire?

The conference continued for an hour and then closed with the following remarks by the President:

Do not misunderstand me, because I have mentioned these objections. They indicate the difficulties that have thus far prevented my action in some such way as you desire. I have not decided against a proclamation of liberty to the slaves, but hold the matter under advisement. And I can assure you that the subject is on my mind, by day and night, more than any other. Whatever shall appear to be God's will I will do.

On the 22d of September, nine days after the preceding conference, the President issued his proclamation, declaring "that hereafter, as heretofore, the war will be prosecuted for the object of practically restoring the constitutional relation between the United States and each of the States and the people thereof in which States that relation is or may be suspended or disturbed;" that at the next session of Congress the proposition of emancipation with compensation in the Union slaveholding States would be again recommended; and that on January 1st, 1863, "all persons held as slaves within any State or designated part of a State the people whereof shall then be in rebellion against the United States, shall be then, thenceforward, and forever free; and the Executive Government of the United States, including the military and naval authority thereof, will recognize and maintain the freedom of such persons, and will do no act or acts to repress such persons, or any of them, in any efforts they may make for their actual freedom." (See PUBLIC DOCUMENTS).

This declaration was received with great joy by the anti-slavery portion of the people. Those of different views took decided grounds against the measure. Their views were expressed at the State conventions held in the different States preparatory to an approaching

election. (See the States respectively.) In the Confederate States attempts were made by some to use this act for the purpose of exasperating the spirit of the Southern people, but there were others who declared it a *brutum fulmen*, which had been exacted of the Federal Government, and powerless to injure them. The Administration was now completely on an anti-slavery platform. The extreme abolitionists had grown from a small handful to a mighty host, and held the sword and the purse of the nation in their hands. The republican party, as such, could only follow the footsteps of their leader, and give to his measures their hearty support. Or, rather, the fact was that the President followed the footsteps of the party. As is usual, in all parties the men of extreme views finally rule, unless they are seasonably sloughed off. So the republican party furnished no exception. They were in advance of the President in adopting extreme anti-slavery views. On the 13th of March, Congress passed an act making an additional "article of war," which practically made all the camps of the army "cities of refuge" to the flying slave. On the 17th of July it passed another act, declaring forever free the slaves of all disloyal persons who escaped or came under the control of the Federal Government, &c. These acts were expressive of the views of the citizens by whom the members of Congress were elected. They show the change of views which had taken place in the minds of a majority of the members, when it is remembered that the same body of men in July, 1861, adopted a resolution, a part of which was as follows: "That this war is not prosecuted upon our part in any spirit of oppression, nor for any purpose of conquest or subjugation, nor for the purpose of overthrowing or interfering with the rights or established institutions of those States; but to defend and maintain the supremacy of the Constitution and all laws made in pursuance thereof, and to preserve Union, with all the dignity, equality, and rights of the several States unimpaired," &c. The vote in favor of the resolution, in the Senate, was, ayes 30, noes 4; in the House, ayes 117, noes 2. On the same day on which the proclamation was issued a convention of governors from most of the free States assembled in Altoona, in Pennsylvania. The sessions of this extraordinary assemblage were held in secret, and its designs and proceedings were never directly known. It was charged that their purpose was to press the Administration to place in the hands of persons of strict anti-slavery views the execution of military affairs. However this may have been, an address was prepared and presented in person to the President; which thus spoke of the emancipation proclamation:

We hail with heartfelt gratitude and encouraged hope the proclamation of the President, issued on the 22d instant, declaring emancipated from their bondage all persons held to service or labor as slaves in the rebel

States, whose rebellion shall last until the first day of January now next ensuing. The right of any persons to retain authority to compel any portion of the subjects of the national Government to rebel against it, or to maintain its enemies, implies in those who are allowed possession of such authority the right to rebel themselves; and, therefore, the right to establish martial law or military government in a State or Territory in rebellion, implies the right and duty of the Government to liberate the minds of all men living therein by appropriate proclamations and assurances of protection, in order that all who are capable, intellectually and morally, of loyalty and obedience, may not be forced into treason as the unwilling tools of rebellious traitors. To have continued indefinitely the most efficient cause, support, and stay of the rebellion, would have been, in our judgment, unjust to the loyal people whose treasures and lives are made a willing sacrifice on the altar of patriotism—would have discriminated against the wife who is compelled to surrender her husband, against the parent who is to surrender his child to the hardships of the camp and the perils of battle, in favor of rebel masters permitted to retain their slaves. It would have been a final decision alike against humanity, justice, the rights and dignity of the Government, and against sound and wise national policy. The decision of the President to strike at the root of the rebellion will lend new vigor to the efforts and new life and hope to the hearts of the people. Cordially tendering to the President our respectful assurances of personal and official confidence, we trust and believe that the policy now inaugurated will be crowned with success, will give speedy and triumphant victories over our enemies, and secure to this nation and this people the blessing and favor of Almighty God. We believe that the blood of the heroes who have already fallen, and those who may yet give their lives to their country, will not have been shed in vain.

This address was signed by the following governors of States: A. G. Curtin, Penn.; John A. Andrew, Mass.; Richard Yates, Ill.; Israel Washburne, jr., Me.; Edward Salomon, Wis.; Samuel J. Kirkwood, Iowa; O. P. Morton, Ind., by D. G. Rose, his representative; Wm. Sprague, R. I.; F. H. Pierpont, Western Va.; David Tod, Ohio; N. S. Berry, N. H.; and Austin Blair, Mich.

The only ground upon which the Government could rest for authority to adopt this measure was, that it was a military necessity. Whether it was so or not, this is not the place to argue. In estimating public measures, however, in the light of history, facts should be considered. The white male population of the Federal States was 13,690,864. The white male population of the Confederate States was 5,449,468. The number of troops which the Federal Government had called into the field was upward of 1,000,000. (*See ARMY, UNITED STATES.*) The number of troops which the Confederate Government had in the field was 400,000. (*See ARMY, CONFEDERATE.*) The Federal Government had a navy which was only third in rank in the world, and more ironclads than any other nation. (*See NAVY, UNITED STATES.*) The Confederate Government had a navy, which at that time consisted of a single ship on the ocean. (*See NAVY, CONFEDERATE.*) The people of the Federal States had a commerce afloat all over the world. The people of the Confederate States had not a single commercial vessel that dared to venture freely upon

the ocean. The people of the Federal States were the rivals of the greatest nations in manufactures of every kind. The people of the Confederate States had few manufactures, and those of inferior articles. The Government of the Federal States possessed the Treasury of the United States, a nation of eighty years, with its vast resources. The Confederate States had no treasury nor financial resources. The ambassadors and representatives of the former were welcomed at every court in the world. The representatives of the latter were not recognized anywhere.

Five days before the proclamation was issued, the battle of Antietam was fought, which was the turning point of the war, and decided it in favor of the Federal States.

The Secretary of War, in his report at the commencement of the session of Congress, December, 1862, thus describes the military necessity which rendered emancipation necessary:

It is seen that a force has been placed by the people of the United States at the command of the Government to maintain its authority more mighty in all the elements of warlike power than was ever before arrayed under one banner. How shall that force be employed? To smite the enemy on every hand, to attack his armies and strongholds, to occupy his ports, clear the great rivers of the West of his obstructions, and pause not until he is subdued, is our plain duty. Above all, it is our duty to disdain no legitimate aid that may save the lives of our gallant soldiers, diminish their labors, provide for their wants, and lessen the burdens of our people. No aphorism is more universally received than that "the sole object of a just war is to make the enemy feel the evils of his injustice, and by his sufferings amend his ways; he must, therefore, be attacked in his most accessible quarter."

The power of the rebels rests upon their peculiar system of labor, which keeps laborers on their plantations to support owners who are devoting their time and strength to destroy our armies and destroy our Government. Whenever that system is in hostility to the Government, it is, in my opinion, the duty of those conducting the war to strike down the system, and turn against the rebels the productive power that upholds the insurrection. Rightly organized in the recovered territory, the laborers of the rebel States will not only aid in holding fortified positions, but their labor will, as in India, free the white soldier from the most unwholesome exposure of the South. They will cultivate the corn and forage which will feed our cavalry and artillery horses, and save the country a portion of the enormous burden now attending their purchase and transport from the North.

A population of four millions true to the interests of the Union, with slight assistance from the army, will, under proper regulation and government, be of the greatest assistance in holding the territory once recovered. The principal staples of the South are the product exclusively of their labor. If protected upon the lands they have heretofore cultivated, with some organization, and with support from small detachments of loyal troops, they would not only produce much of what is needed to feed our armies and their trains, but they would forever cut off from the rebellion the resources of a country thus occupied.

On the 1st of January, 1863, the emancipation was made absolute in the Confederate States, with the exception of a few districts, by the proclamation of President Lincoln.

The proclamation closes with these words:

And by virtue of the power, and for the purpose aforesaid, I do order and declare that all persons held as slaves within said designated States and parts of States are and henceforward shall be free; and that the Executive Government of the United States, including the military and naval authorities thereof, will recognize and maintain the freedom of said persons.

And I hereby enjoin upon the people so declared to be free to abstain from all violence, unless in necessary self-defence; and I recommend to them that, in all cases when allowed, they labor faithfully for reasonable wages.

And I further declare and make known that such persons of suitable condition will be received into the armed service of the United States to garrison forts, positions, stations, and other places, and to man vessels of all sorts in said service.

And upon this act, sincerely believed to be an act of justice, warranted by the Constitution upon military necessity, I invoke the considerate judgment of mankind, and the gracious favor of Almighty God.

Thus the consummation of the original anti-slavery views was verbally reached. But it was attended with disunion, war, and blood.

The consequences of such a measure on the part of the Government depend to a certain extent upon its future action. It satisfied for the moment the extreme anti-slavery friends of the Administration. They, however, insisted that the military action of the Government should be made strictly to conform to this proclamation. How far they were successful the events of the year 1863 will demonstrate.

It is natural to suppose that the military operations of the Government could not escape the effects of this gradual change of policy, which was taking place in the Administration during 1862, especially as the Cabinet contained members who were desirous of seeing this change made. The singular inconsistency was presented of removing a commanding general of the army for certain consequences alleged to flow from his actions, while those consequences were declared in a degree to have created the "military necessity" which justified the Government in adopting the favorite measure of its political friends. For the military campaigns of 1862, *see* ARMY OPERATIONS. The effort, however, was made by the Government to secure an approval of its measures not only from the officers of the army and navy, but from all the people, by designating dissentients as "disloyal" and subjecting the boldest to a sudden and secret arrest and imprisonment. (*See* HABEAS CORPUS.) The dissentients were thereby cut off from exerting any influence whatever in favor of their peculiar views except by that last implement of constitutional liberty,—the secret ballot. The year closed with the friends of the Administration worsted at the polls at almost every election.

It is designed in this article to notice only the political action of the Government during the year. Whatever relates to its finances or foreign relations, which were conducted with much success, or to its immense army and great navy, or to its conduct of the war with the seceded States, will be found elsewhere

under appropriate titles. So likewise the commerce of the country and the developments of the respective States. The legislation of Congress will be found elsewhere.

The appropriations made by Congress at the session closing in the summer of 1862, were summarily as follows:

Legislative, executive, and miscellaneous.....	\$18,997,594
Support of army for 1862.....	238,548,438
Support of navy for 1862.....	80,486,291
Diplomatic and consular.....	1,235,889
Army for 1862 and 1863.....	542,846,846
Navy for 1862 and 1863.....	42,741,838
Indian Department.....	2,117,962
Post Office Department.....	14,744,800
Military Academy.....	156,211
Fortifications.....	7,036,000
Invalid and other pensions.....	1,450,800
Treaty with Hanover.....	44,487

Total.....\$894,905,966

The act passed at the same session for the collection of taxes in the seceded States, was expected to give the United States the complete title to all property of its enemies in those States which could be seized and held. It provided that in all States where obstruction was made to the collection of the taxes by reason of the war, they become chargeable upon all lands within the same, which may thereby be forfeited to the United States, and a summary sale of the same "in fee simple, free and discharged from all prior liens, incumbrances, right, title, and claim whatsoever."

Another act was passed, bestowing pensions upon invalid soldiers and the relatives of those who died:

Every soldier discharged for wounds received in service, or sickness contracted after the day of his enlistment, is entitled to an Invalid Pension.

A full pension for a soldier is \$8 per month from the day of his discharge, if he applies for it within one year from the date of his discharge. If he is not fully disabled, he is not entitled to a full pension, but to that portion of a pension corresponding with his disability. If he is but one fourth disabled, he is entitled to that portion of a pension. Pensions are based on the soldier's degree of disability at the time he makes his application.

Pensions are payable each year, on the fourth of March and the fourth of September.

Widows of officers, soldiers, or seamen, dying of wounds received or of disease contracted in the military or naval service, are entitled to pensions, to date from the day of the soldier's death; also children, under 16 years of age, of such deceased person, if there is no widow surviving, or from the time of the widow's re-marriage.

Mothers of officers, soldiers, or seamen, deceased as aforesaid, providing the latter have left neither widow nor children under 16 years of age, and providing, also, that the mother was dependent, wholly or in part, on the deceased for support. The mother's dependence must be clearly established.



Sisters under 16 years of age of such deceased persons dependent on the latter, wholly or in part, for support, provided there are no rightful claimants of either of the three last preceding classes.

No class of persons is provided for by the pension law except the abovenamed five.

The soldier disabled by sickness is as much entitled to a pension as though he were wounded. Pensions will be granted as soon after they are applied for as the necessary proof can be made, and the necessary examination gone through with, if the claim is properly prepared. For other important acts *see* CONGRESS, U. S.

A treaty was negotiated with Great Britain and ratified unanimously by the Senate for the suppression of the slave trade. It defined and settled within specified limits the right of search, which had been a fruitful source of vexation between the two countries for many years. A similar treaty for the same object was once negotiated with Great Britain by Mr. John Q. Adams, and confirmed by the American Senate with a single amendment, striking out the privilege of search in American waters. This was not acceded to by England, and that treaty failed. Since that time various efforts to adjust the question have been made, but it has remained open—one party frequently exercising the right of visit, if not of search, the other resisting and complaining of it as an insult and aggression, often threatening serious misunderstanding between the two nations. In the present instance Great Britain accedes to the exception, and also confines the exercise of the search to particular vessels, stated in the treaty. *See* PUBLIC DOCUMENTS.

On the 21st of February the first execution under the Federal laws for the suppression of

the slave trade took place in New York. The victim was Nathaniel Gordon, captain of the slaver *Erie*. He was a native of the State of Maine.

During the year diplomatic relations were opened with Hayti and St. Domingo, in compliance with an act of Congress.

At the close of the year but one sentiment animated the people of the Federal States—that was the restoration of the Union and the preservation of the integrity of the country. However much some portions of the citizens might differ from the Administration on minor questions growing out of the existing circumstances, yet such was the patriotism and the devotion of all to these leading objects, that the treasure expended and the lives sacrificed would be regarded as a drop compared with what would be expended if required to succeed.

Nothing had, however, taken place up to that time of the year which indicated any such change of views as would allow of an amicable agreement between the people and Government of the Confederate States and the people and Government of the Federal States on the great question at issue between them—that of negro slavery. To the North no prospect was presented of a close of the war and permanent peace, except by so far destroying the Southern people as to make further resistance an impossibility; to the South there was no prospect of achieving their independence through the weariness or exhaustion of the North, nor any inducement voluntarily to return to the Union, arising out of a change of views or a disposition to concession on the part of the Federal Government. The year 1863 began with fiery Mars in the ascendant.

## V

VAN BUREN, MARTIN, ex-President of the United States, born at Kinderhook, Columbia co., N. Y., Dec. 5, 1782, died at his residence, Lindenwald, in the same town, July 24, 1862. He commenced the study of law at the age of 14, was admitted to the bar of Columbia county in 1803, and appointed surrogate of that county in 1808. In 1812, having been for some years prominent as a member of the democratic party, he was elected to the State Senate, where he gave a hearty support to the war with Great Britain. He was elected in 1814 attorney-general of the State, and in 1816 reelected to the State Senate. In 1818 he effected a new organization of the democratic party of the State, known for many years afterward as the Albany Regency, in opposition to De Witt Clinton, whom he formerly supported. The next year he was removed from the attorney-generalship. In 1821 he was elected to the United States

Senate, and the same year was chosen a member of the State Constitutional Convention. In 1827 he was again elected to the Senate, but resigned in 1828 on being chosen governor of New York, after the death of Governor Clinton. In March, 1829, he became a member of Gen. Jackson's Cabinet, as Secretary of State, and in April, 1831, was appointed minister to England, and entered upon his duties, but the Senate, in its next session (Dec. 1831), by the casting vote of John C. Calhoun, then Vice-President, rejected his nomination; he returned in 1832, and was elected the same year Vice-President. In 1836 he was chosen President by a large majority over Gen. Harrison. The period of his administration was one of great financial embarrassment to the country, the great commercial crisis of 1837 occurring at its very commencement. The passage of the Independent Treasury Bill, which he strong-

ly advocated, and other plans for relief to the country, were the most important of the legislative measures of his administration. He took vigorous measures to prevent American aid to the Canadian insurrection of 1838, better known as the Patriot War. In 1840 he was a candidate for reelection, but was defeated by Gen. Harrison, the embarrassments of the people being attributed to the party whose standard bearer he was. In 1848 he was nominated as the candidate of the "Free Democracy," whose motto was the "Non-extension of Slavery to the Territories," for the Presidency, in opposition to Gen. Cass, who was the candidate of the regular democrats, and to Gen. Taylor, the candidate of the whig party. Gen. Taylor was elected in consequence of this division of his opponents. In 1853-1855 Mr. Van Buren made an extensive tour in Europe. For a more full account of Mr. Van Buren's political career and history see vol. xvi. *New American Cyclopædia*, p. 15, art. VAN BUREN, MARTIN.

VERMONT, the only State of the Union which has remained nearly stationary in population during the ten years ending June, 1860, is saved from an actual loss by only one third of one per cent. The actual increase of the population during that period was 978. (*See UNITED STATES.*)

The elections in the State take place annually on the 1st Tuesday of September. In 1862 the State officers and Legislature and members of Congress were elected. The voters of the State were divided into two parties, the republican and the democratic. A convention of delegates from the former was held at Montpelier, on the 9th of July, and nominated, for reelection, as governor, Francis Holbrook; for lieutenant governor, Paul Dillingham; for treasurer, J. G. Page. The first and last were republicans, the second a democrat. The views of the convention were expressed by the adoption of resolutions "in favor of the confiscation of the slaves and property of rebels, urging the speedy and effectual suppression of the rebellion, approving the general policy of the national Administration, and pledging Vermont to furnish men and money to the last extent of her ability; tendering hearty thanks to the brave and patriotic soldiers in the field, and thanking Governor Holbrook for the prompt manner in which he tendered to the President Vermont's quota of 300,000 additional soldiers.

"Another resolution, accepting certain special acts of President Lincoln as pledges that the Government has cut itself free from all complicity with slavery, was, after an animated debate, adopted with but few dissenting voices."

A convention of delegates from the democratic party was subsequently held, which nominated for governor Benj. H. Smalley; lieutenant governor, E. A. Chapin; State treasurer, George Washburn. The views of the convention were expressed by the following resolutions, which were unanimously adopted:

*Resolved*, That in the present distracted state of our

national affairs, and having continued confidence in the national and conservative principles and practices of the democratic party, we recommend to democrats the preservation of the democratic organization as one of the methods of patriotically saving the country.

*Resolved*, That it is the duty of every citizen in the present national crisis to support the Government in all constitutional efforts to subdue the existing rebellion and vindicate the authority of the Constitution over the whole country.

*Resolved*, That while we regret the existence of four or five millions of negroes in this country as slaves, we are unwilling to sacrifice the Constitution and the Union, or the interests of the white race, for the fancied or real grievances of the black race.

*Resolved*, That the abolition and radical opinions of a portion of the people of the North have been largely productive of the present war and national difficulties, and we record our hearty condemnation of the action of that class of our citizens in Congress or elsewhere.

The votes of the electors for 1862 were given as follows: republican, 80,032; democratic, 8,724. The majority of President Lincoln in 1860 over all others was 22,970. The Legislature elected was without any party division. It convened on the second Thursday in October. The message of the governor thus describes the political views of the people of the State:

It is an occasion for renewed congratulation that the people of Vermont have again shown their devotion to the cause of the Union by laying aside, almost unanimously, all considerations of a partisan character and uniting in earnest support of the national Government, which is charged with the high duty of defending and maintaining that sacred cause. The position of Vermont in this great life-struggle of the nation can neither be questioned nor misunderstood. The blood of her sons has reddened many battle-fields, and their valor and endurance have vindicated her historical renown. Her people admit no thought of concession to or compromise with the causeless and wicked rebellion now striking at the vitals of the nation, and their determination is fixed to endure and fight and sacrifice till the Government established by the wisdom, the patriotism, and blood of our fathers is restored in its beneficent and rightful sway over every portion of our Union.

The receipts into the State treasury for the year ending September 1, 1862, were \$1,442,509, and the disbursements \$1,218,250, leaving a balance in the treasury of \$224,250. The liabilities of the State on September 1 were \$1,164,977, and the resources \$552,868, of which \$284,988 is a balance due from the United States. The indebtedness of the State in excess of its resources is funded in State bonds, payable in ten years from June 1, 1860. The expenses of the ensuing year were estimated at \$1,334,839.

Solomon Foot was reelected by the Legislature as senator in Congress, and L. P. Polard was reelected chief justice of the State.

The number of men sent to the army previous to the call in July for 300,000 men was 10,065. In answer to the call of July 4, 1,164 volunteered, and in answer to the call for nine months' men 4,777 volunteered. The entire quota of the State was completed without a draft.

There are three colleges in the State, two theological schools, and three medical schools.

The number of academies in the State is 84, of private and select schools 292. The num-

ber of common school districts in the State is 2,928; the number of children between four and eighteen years of age 89,599; the number of them attending schools 63,728. The amount of public money distributed was \$105,165.

VIRGINIA, the most populous of the Southern States, increased in the number of inhabitants 174,657 during the ten years ending June 1860. (*See UNITED STATES* for further details of the census.)

The State of Virginia, by its local position and resources, occupied the most prominent position in the Confederate States. The Confederate capital was located within her borders, and the strength of the Confederacy was exerted to preserve her from occupation by the Federal troops. The considerations which induced the State to secede from the Union were stated by the governor, in a message to the Legislature of the State, on the 6th of Jan. 1862, to have been as follows:

Virginia dissolved her connection with the Government of the United States on the 17th day of April last, having watched closely the political conduct of President Lincoln and his cabinet from the 4th of March preceding. A large portion of our people believed, from the revelations of his inaugural message, that he designed to subjugate the South, and much of his policy, as developed in the first six weeks of his administration, tended to confirm and strengthen this belief. The appearance of his proclamation, however, calling on Virginia and other States for volunteers, removed all doubts, and made it plain and palpable that subjugation was his object. He had revealed his purpose by the issue of his proclamation, to use Virginians, if possible, in coercing their Southern slaveholding brethren into submission to his will and obedience to his Government and authority. Virginia, seeing that the only hope of preserving her rights and honor as a State, and the liberties of her people, consisted in dissolving her connection with the Government of the United States and resuming her sovereignty, adopted that course, and subsequently determined to unite her destiny with her Southern sisters. She did so; and her convention, being at the time in session, adopted such ordinances and regulations as were necessary to protect her citizens against the machinations of enemies at home and the encroachments of enemies from abroad.

Events that have transpired since the 17th day of April last have more than confirmed the worst apprehensions of the people of Virginia, and have furnished an ample and complete justification for the secession of the State. All the wicked results apprehended when she seceded have been fearfully realized, and they now constitute an important chapter in the history of the stirring times in which we live.

Such were the considerations that influenced and determined the action of Virginia.

The term of office of the governor expires on Jan. 1, 1864. The Legislature of the State assembles annually at Richmond on the second Monday of January. Some matters of a general interest took place at the regular session in 1862. Two Senators were elected to the Confederate Congress, viz., R. M. T. Hunter and Wm. Ballard Preston. The other candidates nominated were James Barbour and Wm. O. Rives. The State convention had, at its last session, passed a bill providing for the enrollment of free negroes to be drafted to serve in the Confederate army for the term of one

hundred and eighty days. A bill was passed subjecting the enrolling officers to a fine of fifty to a hundred dollars for neglect to discharge their duty. An amendment to reduce the time to one hundred and twenty days, out of regard to the families of the negroes, was rejected.

On the successes of the Federal troops in Kentucky and North Carolina, the governor sent a message to the Legislature, urging them to prepare for the danger which threatened. He said:

"A crisis is upon us. The results of recent reverses to our arms at Mill Springs, Fort Henry, and Roanoke Island appeal in the strongest terms to our patriotism, and demand an exhibition of all our energies, an uncompromising spirit, and stern and determined resolution.

The exigencies of the times are not duly appreciated by many of our people; the dangers which environ us are too lightly estimated. We must see and feel their imminence before we can be aroused to that action which is necessary to save us from alarming ills, and to avert evils which threaten our existence, our peace, and our organization as a government.

It cannot but be apparent to every mind that the object of our enemies is to cut off our southern connections by railroad and otherwise, and to defeat the transportation of troops from one point to another with certainty and celerity, as our necessities may demand. This result accomplished, and one great step will have been taken toward their success and our subjugation."

He further remarked that the capture of Richmond, which is the special purpose of the Federal Government, would be an irreparable blow to the Confederate cause, as the city was rendering it great aid by its mechanical and manufacturing resources. Therefore, in order to save that city and other cities, and prevent the subjugation of Virginia, he proposed that the male inhabitants of all the cities and towns be subjected to ordinary and extraordinary draft, by which means all males between the ages of sixteen and sixty would be available for the defence of the State. He also proposed that the Legislature should require all places of business to be closed at 2 o'clock P. M., and the whole force drafted as aforesaid to turn out for discipline and instruction.

On the call for troops by the Confederate Government, the Legislature passed a bill which provided for filling up the companies in the field to 100 men, authorized the governor to call for volunteers, and, if the requisite number was not obtained, to make a draft from the enrolled militia.

Even at this date the distillation of whiskey had increased to such an extent as to affect the supply of corn. Two hundred establishments had commenced within six months. Petitions from all quarters of the State were sent to the Legislature, requesting that its distillation should be prohibited. This was done by an act of that body.

An other act was passed prohibiting the issue of licenses to sell any kind of merchandise to foreign-born citizens who had not been naturalized. The reason of this was, because such persons, in order to avoid the draft for

soldiers put themselves under the protection of foreign consuls.

Another act prohibited the issue of licenses for a less period than a year, and annulled the permission to dealers to close out by auction. Instead of increasing, this measure diminished the State revenue. The first week in May was signalized as the great week of auctions in Richmond. Many first-class houses were thus closed. The blockade prevented these houses from replenishing their stocks of goods, but they would have continued in business with the remnants of their stock if they had been allowed to take out licenses for fractions of a year, and then sell out at auction.

The regular session of the Legislature closed in March, but an extra session was commenced soon after.

As the Federal army approached the capital, Richmond, the determination of the authorities to defend it increased. It was regarded as the point in which "centered the hopes and apprehensions of the South." The Legislature adopted a resolution relative to its defence, and the governor issued the following proclamation:

The General Assembly of this commonwealth having resolved that "the capital of the State shall be defended to the last extremity, if such defence is in accordance with the views of the President of the Confederate States, and having declared that whatever destruction and loss of property of the State or individuals shall thereby result will be cheerfully submitted to, and this action being warmly approved and seconded by the Executive,

Therefore, I do hereby request all officers who are out of service, from any cause, and all others who may be willing to unite in defending the capital of this State, to assemble this evening at the City Hall, at 5 o'clock, and proceed forthwith to organize a force to co-operate with the Tredegar battalion, and any other force which may be detailed for the purpose indicated. The organization, upon being reported to the Executive, will be recognized and properly officered, as prescribed by law, and be subject to the orders of the Governor, for local defence, under regulations to be hereafter prescribed.

Prompt and efficient action is absolutely necessary. We have a gallant army in the field, upon whom we fully and confidently rely; but no effort should be spared which can contribute to the noble object. The capital of Virginia must not be surrendered. Virginians must rally to the rescue.

Given under my hand and under the seal of the [L. s.] the Commonwealth, at Richmond, this 15th day of May, 1862, and in the eighty-sixth year of the Commonwealth.

JOHN LETCHER.

The following resolution relative to partisan rangers was adopted on May 17:

Whereas this General Assembly places a high estimate upon the value of the ranger or partisan service in prosecuting the present war to a successful issue, and regards it as perfectly legitimate, and it being understood that a Federal commander on the northern border of Virginia has intimated his purpose, if such service be not discontinued, to lay waste by fire the portion of our territory at present under his power:

Resolved by the General Assembly, That, in its opinion, the policy of employing such rangers and partisans ought to be carried out energetically, both by the authorities of this State and of the Confederate States, without the slightest regard to such threats.

A message of the governor to the Legisla-

ture at the beginning of this extra session, May 5, states that a conscription act has been passed by the Confederate Congress. His views in relation to it were thus expressed:

Since your adjournment the Confederate Congress have passed a conscription bill, which relieves the General Assembly, in a great measure, from the necessity of further legislation in regard to military matters. This bill divests the State authorities of all control over the troops of Virginia, and vests in the Confederate Government the power to enroll all persons between the ages of eighteen and thirty-five, organize them, commission the officers, call them into service, and dispose of them in such manner as they may deem advisable.

It is my deliberate conviction that this act is *unconstitutional*, but, taking into consideration the peculiar condition of affairs existing at the time of its passage, I forbear to debate the question at present. When the war is ended we can discuss these questions, and so settle them as to preserve the rights of the States. Harmony, unity, and conciliation are indispensable to success now, and I will, as the Executive of the State (protesting against it as an infringement of State rights), acquiesce in its passage, and respectfully and earnestly urge upon our people, as I have uniformly done, a prompt and cheerful response to its requirements. Drive the invader from our soil, establish the independence of the Southern Confederacy, and then we can mark, clearly and distinctly the line between State and Confederate authority.

The loss of slave property sustained by the citizens of the State at this time was estimated by the governor to exceed the loss from the destruction of cotton or any other species of property. The counties in Virginia which had been overrun contained an aggregate slave population of 80,728, valued at \$45,000,000, which had been lost to the citizens.

The principle of emancipation with compensation proposed by President Lincoln in a message to Congress in March, attracted some attention at Richmond, and the following joint resolution indicative of some of the views entertained respecting it was introduced into the Senate:

The General Assembly of Virginia doth hereby declare that negroes in slavery in this State and the whole South (who are withal in a higher condition of civilization than any of their race has ever been elsewhere), having been a property of their masters for two hundred and forty years, by use and custom at first, and ever since by recognition of the public law in various forms, ought not to be, and cannot justly be, interfered with in that relation of property by the State, neither by the people in convention assembled to alter an existing constitution, or to form one for admission into the confederacy, nor by the representatives of the people in the State of the Confederate Legislature, nor by any means or mode which the popular majority might adopt; and that the State, whilst remaining republican in the structure of its government, can lawfully get rid of that species of property, if ever, only by the free consent of the individual owners, it being true, as the General Assembly doth further declare, that for the State, without the free consent of the owner, to deprive him of his identical property, by compelling him to accept a substituted value thereof, no matter how ascertained, or by the post nati policy, or in any other way not for the public use, but with a view to rid the State of such property already resident therein, and so to destroy the right of property in the subject, or to constrain the owner to send his slaves out of the State, or else to expatriate himself and carry them with him,

would contravene and frustrate the indispensable principles of free government; and whereas these Confederate States, being now all slaveholding, may be disturbed by some act of the majority in any one of them in derogation of the rights of the minority unless this doctrine above declared be interposed; therefore,

*Resolved, by the General Assembly of Virginia,* That the Governor of Virginia be, and he is hereby, requested to communicate this proceeding to the several governors of the Confederate States, and to request them to lay the same before their respective legislatures, and to request their concurrence therein in such way as they may severally deem best calculated to secure stability to the fundamental doctrine of Southern civilization which is hereby declared and proposed to be advanced.

Mr. Collier, the member who submitted the resolution, thus explained his purpose :

His reason for forbearing to ask a vote at this time, he said, was that he did not believe the public men of the South appreciate the doctrine announced. They do not appreciate it at its vital and most valuable point, which is its denial of the power of the majority, in making a constitution for a State, to disturb a pre-existing and resident property. The prevalence of this doctrine in the intelligence of the world can alone give the slaveholding States exemption from war. It is the repudiation of this doctrine that is at the top and bottom, and in all the circumference of the struggle in which we are engaged. If the principal sentiments asserted in that declaration, and from which the doctrine proposed as the practical result is deduced, be not sound in the philosophy of the subject, and ought not to be adopted into the public law, then negro slavery ought to be abolished, and Divine wisdom will accomplish the deliverance. But, he said, he did believe the sentiments sound and the doctrine logically inevitable, and that negro slavery will exist in the countries governed by the white race until the native land of the black man shall have been civilized and Christianized. Mr. Collier said he would only now add the desire that every newspaper in the Confederacy, and as many elsewhere as will, would publish that declaration.

On the 10th of May the Legislature adjourned to the first Monday in December. But on the 15th of Sept. another special session was held. It was called together in reference to the scarcity of salt, which had become alarming. The proclamation of the governor calling an extra session thus explains the cause :

*Whereas,* it is represented by many citizens of this State that it is impossible to obtain supplies of the necessary article of salt, except at fabulous prices, and even then not in sufficient quantities to supply the demand, and a portion of the salt works of the Commonwealth, from which a large quantity of salt was derived, being in possession of the public enemy, and the remaining works, being owned by private persons and carried on by private enterprise, are insufficient to furnish the amount necessary for the consumption of our own people, and yet a large proportion of the annual product of the works is continually exported into the neighboring States :

*And whereas* the importation of foreign salt has been prevented by the blockade of our ports, and it is not probable that the demand can be supplied from that source; and the season is rapidly advancing when it will be necessary to salt up meats for the ensuing year to provide our armies and people with suitable provision; and the Legislature having made no appropriation of money to purchase or to manufacture this essential article, or to provide a remedy.

The result was the prohibition of the export of salt from the State, except upon contracts which had been previously made with the

Confederate Government, until the State was supplied.

At this session the following resolutions were offered in the Senate, relative to President Lincoln's emancipation proclamation :

*Whereas* Abraham Lincoln, President of the United States, by his recent proclamation, is acting in stolid contempt of the principles of property in slaves of African descent, which is no less consecrated in their Federal Constitution than in ours, and is aiming, by his said proclamation, to excite a servile insurrection in our midst :

*Resolved,* therefore, That no person within this State shall be held to have committed any offence against the criminal laws thereof, or shall be tried, or imprisoned, or required by any magistrate, or judge, or police officer, to answer at any time for any act done in driving from the State, or putting to death by any means, any person, with or without arms, who may be found on our soil, aiding or abetting in any way to give effect in this State, or on its border, to the lawless and fiendish purposes of the said proclamation.

No action was taken upon it, and the Legislature, after a brief session, adjourned.

The new Constitution which had been drafted by the State convention was submitted to the voters of the State in March, and rejected.

The active state of hostilities within the limits of the State during the year interfered with all peaceful pursuits. The manufacturing industry of the people in the cities was occupied by the demands of the Confederate Government. Agriculture suffered by the reduction of laborers and the laying waste of the fields, except in those parts of the State removed from the scene of hostilities. Commerce was entirely cut off. The public institutions of education were closed, and the teachers became officers in the army. With wonderful earnestness and simplicity, Virginia sacrificed everything for the success of the Confederate Government. With the single exception that she would not allow conscripts to be taken from the camps of her militia, all the demands of the latter were acceded to. The spirit of ex-Gov. Floyd prevented this invasion of what was deemed her State rights. Her blood and treasure, however, were poured out as no State is recorded to have done either in ancient or modern history. She gave the Confederate service, from her own armories and stores, 75,000 rifles and muskets, 233 pieces of artillery, a magnificent armory, containing all the machinery necessary for manufacturing arms on a large scale, and, after draining her arms-bearing population to the dregs in service of the Confederacy, raised a force of her own people to drive the Federal troops from her western border, which the Confederate Government were either unable or unwilling to do.

VIRGINIA, WESTERN, which consists of the counties west of the Alleghany Mountains, has been represented in both houses of Congress and finally formed into an independent State. The proceedings which have been taken to reach this result of the formation of a new State out of a part of a State are so important as to require an accurate description.

In the winter of 1860-'61 the Legislature of the State of Virginia was convened in special session to consider the exigencies pressing upon the country in consequence of secession of the Gulf States. That Legislature passed a law directing the people of Virginia to elect delegates to a convention to be held on February 14th, at Richmond, to determine the duty of the State under the extraordinary circumstances with which she was surrounded. A vote was required to be taken at the same time when the delegates were elected, to decide whether, if the convention passed an ordinance of secession, it should be referred back to the people for their adoption or rejection. The majority of votes in favor of such reference was nearly sixty thousand. The convention assembled, an ordinance of secession was passed and formally referred to the people to be voted upon on the 4th Tuesday of May, 1861. The authorities of the State began to levy war against the United States on the next day after the passage of the ordinance, and Virginia was immediately annexed to the Confederate States, and their troops immediately occupied portions of the State. Mass meetings were immediately held in Western Virginia to take into consideration the best means of preserving their allegiance to the United States. A convention of nearly five hundred delegates assembled there early in May, 1861, which declared the ordinance of secession to be null and void; that its provision suspending the election of members of the Federal Government was a usurpation, and that if the ordinance of secession was ratified by a vote they recommended the election on June 4th of delegates to a general convention to be held on the 11th to devise such measures as the welfare of the people might demand. This convention met at Wheeling. Meantime nearly all the judicial and executive officers in that part of the State had fled to Richmond before the Federal forces. Legal protection to life, liberty, or property was given up. This convention declared the office of governor, &c., vacant, "by reason of those who occupied them having joined the rebellion," and proceeded to fill those offices. The action of this convention was not confined to Western Virginia, but intended to embrace the whole State. The governor elected thus stated the object of the convention:

It was not the object of the Wheeling convention to set up any new government in the State, or separate, or other government than the one under which they had always lived. They made a single alteration in the Constitution of the State, which prescribes the number of delegates in the General Assembly which shall be necessary to constitute a quorum.

A declaration was made by the convention, and an ordinance adopted for the reorganization of the State Government. According to this ordinance the Government to be reorganized, either in its executive or legislative departments, was not for a part of the State, but for all of Virginia. In conformity with

VOL. II.—51 A

this ordinance a State Government was reorganized in all its branches in every county of the State not occupied by an armed foe.

On the 20th of August, 1861, the convention passed an ordinance "to provide for the formation of a new State out of a portion of the territory of this State." In compliance with its provisions delegates were elected to a constitutional convention which assembled at Wheeling, Nov. 26, 1861, and proceeded to draft a Constitution, which was submitted to the people on the first Thursday of April, 1862. The vote in favor was 18,862, that against it was 514.

The governor appointed by the convention of June, 1861, which declared the State offices vacant, now issued his proclamation convening an extra session of the Legislature, elected and organized under the same authority, and which claimed to be the Legislature of Virginia. This Legislature met on the 6th of May, 1862, and passed an act, giving its consent to the formation of a new State, and forwarded its consent to the Congress of the United States, together with an official copy of the Constitution adopted by the voters, and with the request that the said new State be admitted into the Union.

On the 31st of December, 1862, the following act of Congress was approved by the President:

*An act for the admission of the State of "Western Virginia" into the Union, and for other purposes.*

Whereas the people inhabiting that portion of Virginia known as West Virginia did, by a convention assembled in the city of Wheeling on the twenty-sixth of November, eighteen hundred and sixty-one, frame for themselves a Constitution, with a view of becoming a separate and independent State; and whereas at a general election held in the counties composing the territory aforesaid on the third day of May last, the said Constitution was approved and adopted by the qualified voters of the proposed State, and whereas the Legislature of Virginia, by an act passed on the thirteenth day of May, eighteen hundred and sixty-two, did give its consent to the formation of a new State within the jurisdiction of the said State of Virginia, to be known by the name of West Virginia, and to embrace the following named counties, to wit: Hancock, Brooke, Ohio, Marshall, Wetzel, Marion, Monongalia, Preston, Taylor, Tyler, Pleasants, Ritchie, Doddridge, Harrison, Wood, Jackson, Wirt, Roane, Calhoun, Gilmer, Barbour, Tucker, Lewis, Braxton, Upshur, Randolph, Mason, Putnam, Kanawha, Clay, Nicholas, Cabell, Wayne, Boone, Logan, Wyoming, Mercer, McDowell, Webster, Pocahontas, Fayette, Raleigh, Greenbrier, Monroe, Pendleton, Hardy, Hampshire, and Morgan; and whereas both the convention and the Legislature aforesaid have requested that the new State should be admitted into the Union, and the Constitution aforesaid being republican in form, Congress doth hereby consent that the said forty-eight counties may be formed into a separate and independent State. Therefore—

*Be it enacted by the Senate and House of Representatives of the United States of America in Congress assembled, That the State of West Virginia be and is hereby declared to be one of the United States of America, and admitted into the Union on an equal footing with the original States in all respects whatever, and until the next general census, shall be entitled to three members in the House of Representatives of the United States: Provided, always, That this*

act shall not take effect until after the proclamation of the President of the United States hereinafter provided for.

It being represented to Congress that since the convention of the twenty-sixth of November, eighteen hundred and sixty-one, that framed and proposed the Constitution for the said State of West Virginia, the people thereof have expressed a wish to change the seventh section of the eleventh article of said Constitution by striking out the same and inserting the following in its place, viz.: "The children of slaves born within the limits of this State after the fourth day of July, eighteen hundred and sixty-three, shall be free; and that all slaves within the said State who shall, at the time aforesaid, be under the age of ten years, shall be free when they arrive at the age of twenty-one years; and all slaves over ten and under twenty-one years, shall be free when they arrive at the age of twenty-five years; and no slave shall be permitted to come into the State for permanent residence therein:"

Therefore,  
 Sec. 2. *Be it further enacted*, That whenever the people of West Virginia shall, through their said convention, and by a vote to be taken at an election to be held within the limits of the said State, at such time as the convention may provide, make and ratify the change aforesaid, and properly certify the same under the hand of the President of the Convention, it shall be lawful for the President of the United States to issue his proclamation stating the fact, and thereupon this act shall take effect and be in force from and after sixty days from the date of said proclamation.

Approved, Dec. 31, 1862.

These conditions were subsequently complied with by the citizens, and the President of the United States issued his proclamation accordingly:

The following is a provision of the Constitution of the United States:

New States may be admitted by the Congress into this Union; but no new States shall be formed or erected within the jurisdiction of any other State, nor any State be formed by the junction of two or

more States, or parts of States, without the consent of the Legislatures of the States concerned, as well as of the Congress.

The following is the population of the counties embraced in this new State according to the census of 1860:

COUNTIES.	White population.	Slaves.	COUNTIES.	White population.	Slaves
Hancock.....	4,449	9	Lewis.....	7,796	290
Brooke.....	5,425	18	Gilmer.....	2,685	58
Ohio.....	22,196	100	Calhoun.....	2,492	9
Marshall.....	12,936	29	Braxton.....	4,835	104
Wetzel.....	6,691	10	Clay.....	1,761	21
Pleasants.....	2,926	15	Nicholas.....	4,470	154
Wood.....	10,791	176	Fayette.....	8,716	271
Jackson.....	8,940	55	Raleigh.....	8,291	64
Mason.....	8,752	266	Wyoming.....	2,797	..
Cabell.....	7,691	205	McDowell.....	1,535	..
Wayne.....	6,604	143	.....	6,428	363
Logan.....	4,789	148	Monroe.....	9,526	1,114
Boone.....	4,681	158	Greenbrier.....	10,499	1,325
Kanawha.....	13,787	2,184	Pocahontas.....	8,656	252
Roane.....	5,909	72	Webster.....	1,552	8
Wirt.....	3,723	23	Upshur.....	7,064	312
Ritchie.....	6,609	35	Randolph.....	4,793	158
Doddridge.....	5,168	34	Tucker.....	1,896	20
Tyler.....	6,458	18	Putnam.....	5,708	560
Harrison.....	12,185	352	Pendleton.....	6,873	244
Marion.....	12,654	63	Hardy.....	6,521	1,073
Monongalia.....	12,907	101	Hampshire.....	12,451	1,213
Preston.....	15,182	67	Morgan.....	6,618	94
Taylor.....	7,300	112	.....	.....	.....
Barbour.....	8,729	95	Total, 48 cos.....	884,921	12,771

The officers of Western Virginia, at the close of the year, were Francis H. Pierpont, governor; Daniel Palsley, lieutenant-governor; Lucian A. Hugans, secretary; Campbell Tarr, treasurer.

On the 1st of November, 1862, these counties had furnished to the Federal army sixteen regiments of infantry, three regiments of cavalry, and one of artillery, or nearly 20,000 men.

W

WAKLEY, THOMAS, coroner for Middlesex, born in 1795, at South Devon, England, died at Madeira, whither he went for the benefit of his health, May 16, 1862. His earliest tastes were for the sea, and at ten years of age he took a voyage to Calcutta as a midshipman. Upon his return he relinquished his profession at his father's urgent request, and resolved to study medicine. With this object in view he went to a school at Wiveliscombe, and was subsequently apprenticed to an apothecary at Taunton. In 1815 he went to London to complete his medical training, and to attend Sir Astley Cooper's lectures on surgery at Guy's Hospital. In less than eighteen months after entering the hospital he passed his examination at the College of Surgeons, though he continued to attend the borough hospitals for two or three years after, and then settled in Argyle Street, London, in which locality he practised for about three years. In 1823 he retired from practice, and devoted himself to the establishment of the "Lancet," a medical journal, with

which his name has been associated for nearly forty years. At the time of the establishment of the "Lancet" no clinical lectures were delivered in any of the London hospitals, nor were the cases of interest reported. The lectures at the medical schools were confined to the theories of disease and treatment, and the medical students had little opportunity of forming a practical acquaintance with the diagnosis and treatment of the medical and surgical cases they would meet in practice. Mr. Wakley determined to effect a reform in these particulars, and he commenced reporting the lectures of the most eminent professors of medicine and surgery, and the clinical instruction and hospital cases, with the consent of the lecturers when he could obtain it, and without it when he could not. This led to much opposition; he was several times prosecuted for reporting lectures, and, in one instance, removed by policemen from the amphitheatre, but in every case he eventually obtained decisions in his favor. He also effected other reforms in the manage-

ment and efficiency of the Royal College of Surgeons, and in the exercise of the duties of coroners. In short, he made the "Lancet" felt as a power which would be exercised on the side of right, the removal of abuses, and the reform of practices, which injured and dishonored the medical profession. In 1839 he was chosen coroner of Middlesex, which office he held until his death. His ability and eloquence, displayed on several occasions, led his friends to request that he would become a candidate for the representation of Finsbury in Parliament. He was defeated, however, in 1832, and again in 1834, but in January, 1835, was elected, and continued to hold his seat until 1852, when he retired from Parliamentary life. While in Parliament, he always spoke and voted for the abolition of all taxes upon knowledge, and was influential in obtaining a select committee to enquire into the state of medical education and practice, the report of which had great influence on the progress of medical reform.

**WATER WORKS.—BOSTON, COCHITUATE WATER WORKS.** The expenditures, on account of the Water Works, to January 1, 1863, are \$9,526,121.29, from which there should be deducted sundry credits by the city, and amounts received for water rates, \$3,515,303.23, leaving the actual cost of the works, January 1, 1863, \$6,010,818.06. The total amount received for water used during the year ending January 1, 1863, was \$364,036.37. The average daily consumption of water during the year has been 16,600,000 gall., which daily consumption is 1,589,304 gall. less than in the year 1861. The consumption has decreased over one million gallons per day, but the receipts for water used during the year have considerably increased. This saving of water is mainly owing to the number of water meters placed in establishments where large quantities of water are used.

During 3½ days in May, water was wasted from the lake into Sudbury river, amounting in all to 33,200,000 gallons, equal to about 2 days' supply for the city. This was the total amount of waste for the whole year.

During the year there has been a gain of 5 ft. of water in the lake, equal to about 60 days' supply—nearly ¼ of the number of days in the year—but there has been about ¼ more than the average annual rain fall, showing an amount used equal to the average annual rain-fall, and also showing all that the lake can be relied on to furnish annually is used. More storage room is needed with the present means of supply, as well as a new source of supply.

According to Mr. J. P. Hall's measurements of rain fall in Boston, the average annual amount for 29 years previous to 1852 was 42.24 inches; and for ¼ of that time the annual amount was less than the average of 41 inches. In 1828 it was only 32.41 inches.

From 1852 to 1862, inclusive—51.61 inches.

A similar increase has taken place, to a greater or less extent, at neighboring places.

**BROOKLYN NASSAU WATER WORKS.**—Water has been introduced and distributed by means of these works since 1859, but it was not till May, 1862, that the whole works were completed and transferred by the contractors and constructing board to the city.

The works were constructed under the charge of James P. Kirkwood, Esq., chief engineer, by Messrs. H. S. Welles & Co., contractors. The sources of supply are several ponds along the south shore of Long Island, as follows:

Name of Pond.	Area of Pond and Grounds. Acres.	Water Surface. Acres.	Surface above Tide in feet.	Drainage Area. Square Miles.	Minimum Summer Delivery, N. Y. Gallons, per Diem.
Hempstead..	26 <sup>58</sup> / <sub>100</sub>	23 <sup>58</sup> / <sub>100</sub>	10 <sup>58</sup> / <sub>100</sub>	25 <sup>79</sup> / <sub>100</sub>	8,500,000
Rockville....	15 <sup>58</sup> / <sub>100</sub>	8	12	8 <sup>58</sup> / <sub>100</sub>	2,800,000
Valley Str'm.	23 <sup>58</sup> / <sub>100</sub>	17 <sup>78</sup> / <sub>100</sub>	12 <sup>58</sup> / <sub>100</sub>	6 <sup>58</sup> / <sub>100</sub>	2,600,000
Clear Stream.	1 <sup>58</sup> / <sub>100</sub>	1 <sup>07</sup> / <sub>100</sub>	11 <sup>58</sup> / <sub>100</sub>	8 <sup>57</sup> / <sub>100</sub>	800,000
Brookfield....	11 <sup>58</sup> / <sub>100</sub>	8 <sup>75</sup> / <sub>100</sub>	15 <sup>58</sup> / <sub>100</sub>	8 <sup>58</sup> / <sub>100</sub>	2,000,000
Jamaica.....	67 <sup>33</sup> / <sub>100</sub>	40	7 <sup>58</sup> / <sub>100</sub>	10 <sup>58</sup> / <sub>100</sub>	3,800,000
	146 <sup>38</sup> / <sub>100</sub>	99 <sup>18</sup> / <sub>100</sub>		60 <sup>38</sup> / <sub>100</sub>	20,000,000

The average rain fall over this drainage district has been, for the past 37 years, 39 <sup>50</sup>/<sub>100</sub> inches.

The minimum rain fall was, in the year 1835, 23 <sup>75</sup>/<sub>100</sub> inches. The maximum, in the year 1859, was 59 <sup>58</sup>/<sub>100</sub>.

**Main Conduit.**—This starts at Hempstead pond, and leads as directly as the character of the ground admits to the pump well—total length 12½ miles; dimensions, 8 ft. 2 in. wide, by 6 ft. 4 in. high; the top is semicircular, and the bottom an invert of 1 ft. versed sine, side walls vertical 15 in. It is built this size, 2,092 ft. when it receives the water from Rockville pond by a circular conduit 2 ft. in diam. and 8 in. thick. The main conduit is here enlarged by increasing the width 6 in. and the height 3 in., and continues this size 14,094 ft., to the next branch, from Valley stream, 2½ ft. diam. The main is here increased in width 6 in., and in height 3 in., and the entire arch is laid 12 in. thick: it continues this size 4,371 ft., to the next branch of the Clear Stream, 2 ft. in diam. The main is again increased in width 2 in. and in height 1 in., and thus continues 5,400 ft., to the Brookfield branch, 2 ft. diam. The main is here enlarged to a width of 9 ft. 8 inches, and a height of 7 ft. 1 inch., and thus continues over 13,500 feet., to the junction of Jamaica pond branch, 3½ ft. diam., and 8 in. thick. The fall of the conduit to this point is 1 in 10,000. It is built wholly of brick, except in a few short pieces across embankments, where the side walls are strengthened by stone, and a spandrel backing. From this point to the pump well the conduit is 8 ft. 8 in. high, and



10 ft. wide, side walls 8 ft. high, with a fall of 6 in. to the mile: the distance is  $4\frac{24}{100}$  miles.

At the pump wells there are at present 2 engines erected, which, according to the contract, were each to afford a duty of not less than 600,000 lbs., raised 1 ft. high with 1 lb. of coal, and capacity of 10 million New York galls. of water to be raised into the reservoir in 16 continuous hours. The first engine was tested Jan. 1860, and the duty was found to be 607,982 lbs. ft. per lb. of coal; the capacity, for 16 hours, 10,298,102 gallons delivered into the reservoir; diameter of steam

cylinder, 90 inches; length of stroke of piston and pumps, 10 ft.; diameter of barrel of pumps 86 in. The 2nd engine was tested in Jan. 1862, and the duty was found to be 619,037 lbs. ft. per lb. of coal, and the capacity, for 16 hours, 10,652,366 galls.; diameter of steam cylinder, 85 inches; stroke and diameter of pumps same as No. 1 engine.

The two engines differ somewhat in detail, but in general construction are represented by (Fig. 1), which is a section of the No. 2 engine. The engines were built by Messrs. Woodruff & Beach of Hartford, after designs by Mr. Wright.

In the fig. *a* is the steam cylinder with pis-

FIG. 1.

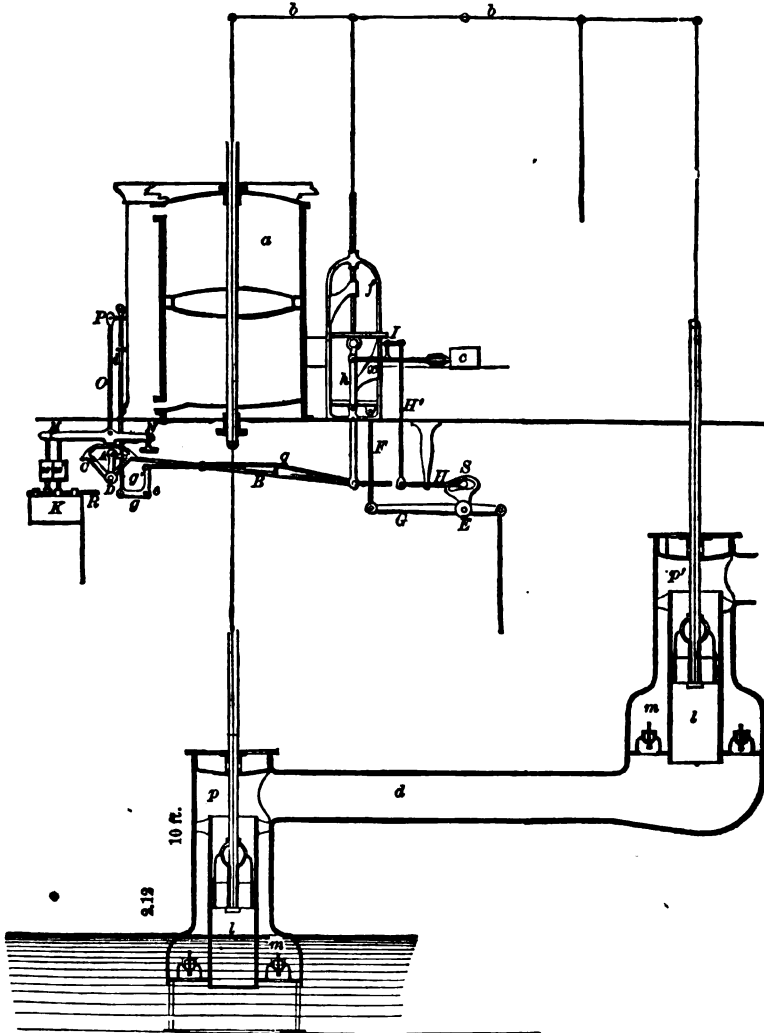

ton, steam, and exhaust ports, like other engines. In the bottom of the steam cylinder is a stuffing box, through which the steam piston rod passes, and is coupled below to the rod of

lower pump, *p*. *b* is the beam, to the one end of which the piston rod is connected by a cross head and links. The upper pump rod is connected to the other end of beam in the

same manner as the steam piston rod. *f* is a frame moving with the beam in guides, which, in combination with the water cylinder, *c*, and roll levers, *h*, works the steam and exhaust valves. *e* is the lower rock shaft, which is connected to the upper or main rock shaft (hung in bearings between the side pipes) by the arms, *gg'*, and rod, *i*. The lower rock shaft is operated from the lower ends of the roll levers, *h*. The piston of the water cylinder, *c*, is connected to the roll lever near its upper end. *C* is a segment, one part of the face being formed on a longer radius than the other (the difference being equal to the lift of the steam valves), and fastened at the centre to the rock shaft *D*. This segment is adjustable by hand, and its office is to close the steam valves, early or late in the stroke, as may be required. The rock shaft *D* is connected, through the arm *A*, by the rod *B*, to an arm on the rock shaft *E*. This latter shaft is operated from the frame, *f*, by the rod *F*, and lever *G*. The valves of the water cylinder, *c*, are operated from the rock shaft *E*, by the cam arm *S*, and rods *H* and *H'*, and right angled arm, *I*. The steam valves are operated by the cataract, *K*, which consists of two small open water cylinders (one for each steam valve), fitted with pistons and weighted with the weights *w*, *w'*. Each plunger rod is connected to one end of a lever, *M*, the other end, *N*, being the fulcrum; this lever is connected to the steam valve stems by the rod *O*, and arm *P*. When the steam valve is closed, it is kept so by a latch bolt, *R*, inserted into a socket in its cataract plunger rod, the latch being moved into gear by a spring on the back of it, and withdrawn by an arm on the rock shaft *e*.

Assuming the piston in the steam cylinder to be at half stroke, and the lower steam valve being still open, the different parts of the gearing described above, and depending on the motion of the beam for theirs, will also be at half movement, but the cataract plunger attached to the lower steam valve will be at the bottom of its cylinder, and the latch, *R*, withdrawn. Now, when the piston has reached that part of the stroke when the lower steam valve ought to be close, and the remainder of the stroke be performed by the expanding steam, the closing face of the segment, *C*, moves under the lever, *M*, by the operation of its connecting rod and arm—as before described—closing the lower steam valve instantly through the rods *O* and *P*, at the same time carrying its cataract plunger to the top of its cylinder, being held there by the latch bolt. The piston continues moving upward until it has reached the point where the lower exhaust and upper steam valves should open: the former operation being performed by the inclined plane, *x*, on the inside of frame, *f*, coming in contact with the roll on the upper end of the lever *h*, moving it out of the perpendicular, at the same time giving a like move-

ment in an opposite direction to the lower end of the lever, which opens—through the rod *g*, and the lower and upper rock shafts—the lower exhaust valve.

The water cylinder, *c*, now comes into play, finishing the operation by carrying the roll lever to its extreme movement quickly, liberating by its action through the rod *g*, and arm on rock shaft *e*, the latch bolt of the upper steam valve cataract plunger, permitting the latter to fall open by the gravitation of its weighted plunger rod, and admitting steam on the upper side of the piston, checking it in its course, and forming a cushion; the valve still being open, the movement of the piston is reversed, and the downward stroke commenced. When the piston has reached the point of "cutting off," the upper valve is instantly closed by the same operation as that described above for the lower steam valve.

The lower pump, *P*, is placed in a well below the engine room floor, and directly under the steam cylinder; the upper pump, *p'*, is also beneath the floor, and connected directly to the opposite end of beam. This pump has a nozzle, *n*, to which the forcing main is joined. Each pump is constructed of two barrels, *l* and *m*; the inside one, *l*, being the working barrel, fitted with a bucket and double-beat valve, and the annular space between them being connected to the suction by 8 double-beat valves.

Their operation is as follows:

The lower pump on its up stroke lifts the water above its bucket through the connecting pipe, *d*, and through the annular valves and valve of descending bucket of upper pump, at the same time charging itself below its bucket by suction. On its down stroke, the upper pump is lifting the charge above its bucket, and filling the space below it by suction; the lower pump again ascends, performing the above operation, each pump moving on its up stroke a column of water about 86 inches in diameter, 10 feet toward the reservoir.

The total expense during the past year of pumping at Ridgewood, including all labor, fuel, repairs to engines and engine buildings, has been \$23,976  $\frac{2}{100}$ . The total number of gallons pumped into the reservoir, has been 1,962,131,200. This shows the cost of pumping, including all repairs to engines and engine buildings, to have been \$12  $\frac{2}{100}$  per 1,000,000 gallons, or one cent and two mills per 1,000 gallons. This should be increased by the amount due to interest on the cost of the engines, engine house, pump well, coal sheds, railroad track, and engineer's house, which was about \$300,000.

Engine No. 1 has been in operation during the year 2,187 hours, delivering 1,197,866,650 gallons. No. 2 has pumped 1,399 hours and delivered 774,641,700 gallons. It will be seen by this that the amount of water pumped the past year exceeds that of 1861 by 23  $\frac{1}{2}$  per cent. The amount of coal consumed when pumping, has been for engine No. 1, 8,376,550 lbs., and

for engine No. 2, 2,070,808 lbs. Duty in lbs. raised one foot high per pound of coal, for engine No. 1, 526,936 feet lbs., and for engine No. 2, 555,628 feet lbs.

The water is raised about 163 feet into the Ridgewood Reservoir, a double reservoir, constructed with earth banks whose inside slopes are lined with stone laid in cement.

The area of water surface is of the

Eastern Division.....	11½ acres.
Western ".....	13½ "

Total water area..... 25½ acres.

The height of the surface of the water, when the reservoir is full, or the water 20 feet in depth, is 170 feet above the Navy Yard high water mark. The total capacity of this reservoir, when full, is 161,000,000 gallons.

From the Ridgewood Reservoir the water is conveyed to the city by a single 36-inch main.

For the supply of a portion of the city above the level of the Ridgewood Reservoir, another engine has been erected at Prospect Hill, with a reservoir at the summit, with earth embankments and brick and cement lining. Its area of water surface is 3½ acres; depth of water, 20 feet; capacity, 20,086,558 N. Y. gallons; height above mean tide, 198 feet. No distributing pipes are yet laid from this reservoir, but it is kept full as a store reservoir against accident to other parts of the work which might reduce the supply or diminish the head in the mains. The engine supplying this reservoir is represented in outline in (fig. 2).

The engine is of the crank and fly-wheel variety. The steam cylinder, *S*, is fitted with slide valves, and a cut-off controlled by a governor. The pumps are constructed on the same general principles and mode of action as the

FIG. 2.

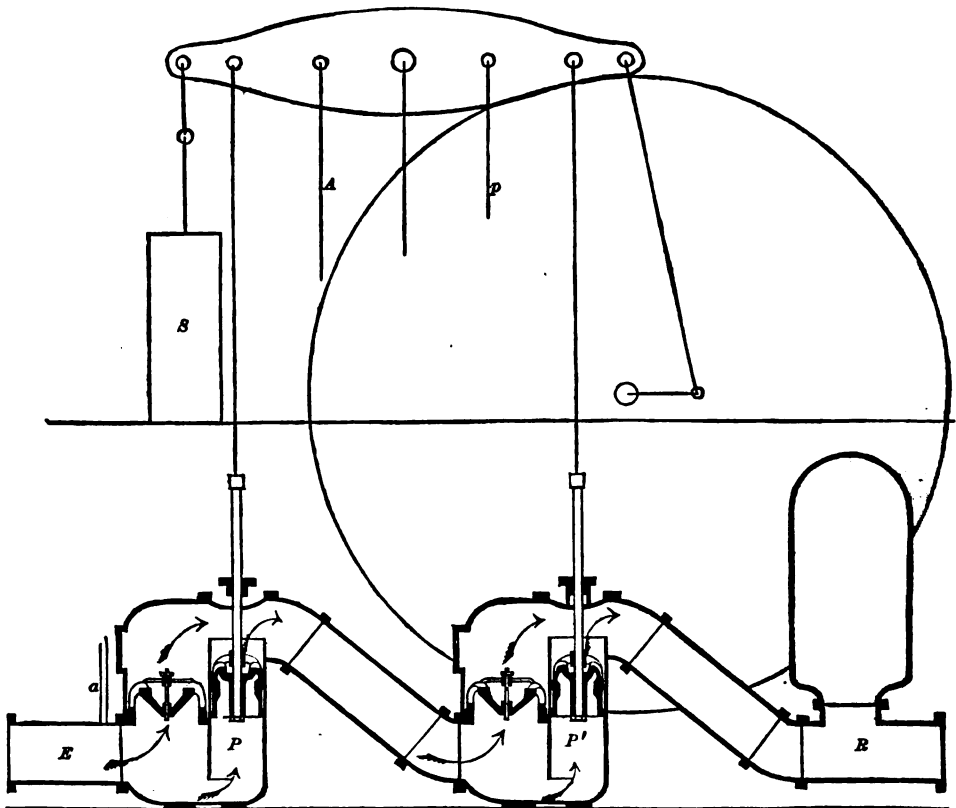

pumps at Ridgewood. They are 2 pumps attached to opposite sides of the working beam; they have valves in their buckets, and in channels at the sides of the pump. The pumps are placed in a branch main, and the water flows into and through the pumps under a considerable head, variable with the draft upon the

mains in other parts of the city. There are 2 air chambers: one shown at *R* on the rising main, the other, and a somewhat larger one, is connected by a branch pipe with the induction pipe at *E*. At *A* are the connections with the air pump. At *p* the connections of a small single-acting plunger pump to supply the boiler

feed, and return the injection water to the main. *P* is the lower pump; *P'* the upper.

STEAM CYLINDER.

Length of stroke, ..... 4 ft. 6 in.  
Diameter of cylinder, ..... 24 inches.

PUMPS.

Length of stroke (average), ..... 3.466 feet.  
Diameter of barrels, ..... 20½ inches.

FLY WHEEL.

Diameter of, ..... 20 feet.  
Length of crank, ..... 27 inches.

Duty pr. test, May, 1862, 649,577 lbs. ft. pr. lb. of coal, for 93 consecutive hours; capacity for the same time 14,557,027 N. Y. gallons delivered into the reservoir.

CINCINNATI.—The average daily consumption has varied from 4,675,800 gallons in February, to 6,793,414 in August, the daily average for the year being 5,643,087 gallons, or about 37½ gallons per head, for a population of 150,000, supplied by the works. The rate as at present charged for manufacturers is 12 cents per 1,000 gallons, to be reduced after the 1st of July next to 9 cents per 1,000 gallons. The demands upon the works are steadily increasing, and the full capacity for supply will be taxed until the new engine is brought into operation. The water is pumped from the river by steam power, and additional works are in progression on which \$184,000 have been spent during the last 2 years. The non-condensing engines of the Cincinnati works consist of two cylinders each 21 inches bore and 10 feet stroke. The two condensing engines have each a cylinder 45 inches diameter, and 8 feet stroke.

DETROIT.—The expenditures to January 23d, 1863, for construction of water works was \$621,283.51. The whole quantity distributed during the year 1862, 999,945,329 U. S. galls. Average daily distribution, 2,725,877 galls., or 45 galls. to each inhabitant of a population of 60,000. The water supply is by means of pumps from the Detroit river, and a new engine has been contracted for, and is nearly finished.

Wood Distribution Pipes.—Tamarack logs have been used for conveying water in this city for 35 years past. When the works were purchased and reconstructed by the city, in 1840, iron mains were used, but tamarack pipes were laid for general service, about ½ of which are still in use. The others were mostly removed to give place to iron pipes of greater capacity, and but few were removed in consequence of being decayed. Of the 18½ miles laid subsequently, 15 miles have failed through neglect in the selection of the logs, or laying them too near the surface of the ground, and have been removed. Consequently from 1852 to 1857 no logs were laid, when, in consequence of the rapid growth of the city and expansion of the settled portions of its limits, a demand was made to supply near 2,000 families residing in sparsely settled districts beyond the lines of water pipes. To supply them by means of even the minimum (4-inch) size iron pipe would have been unremunerative. An investigation

was therefore made as to the failure of the wooden pipes, and it was found that the best logs were those that were first laid about 17 years before, which had been well selected, and laid at sufficient depth, and as the cost of wooden pipes was but ½ that of iron, at this reduced price, the water rates would repay the outlay. A small steam engine and Wykoff's tubular boring machine were bought, since which time 29 miles of logs have been laid, mostly in districts that could not otherwise have been supplied with water from the works with any present prospect of remuneration. The logs are sound green tamarack, not less than 6 inches diameter at the small end, and 8 feet in length. The joints are made with cast-iron thimbles, and the lines are laid 5 ft. below the surface of the earth, mostly on stiff compact clay, and when the soil is sandy the logs are bedded in clay. The entire cost per foot laid has been 15½ cts., which includes the cost of shop, engine, and boring machine.

The average annual rain fall at Detroit for the past 23 years is 48¼ inches.

NEW HAVEN.—Water works have been recently completed for the supply of the city of New Haven, Conn. Water was introduced into the distributing mains Jan. 1, 1862, and there are now laid 24 miles of distributing pipes.

Mill River, the stream from which the supply of water is obtained, has a water shed of over 56 square miles, and a minimum flow of 12,000,000 gallons per day.

The water is backed up by the dam for about 2½ miles, forming Lake Whitney. During the past year the quantity of water in the lake has never been less than 500,000,000 gallons; its average depth is about 20 feet. The dam is a well-built structure of its kind, being laid up with heavy stones, protected from the action of the water by a layer of concrete and that again by a gravel bank. The pipe chamber, built of hydraulic masonry, contains the gate, screens, and pipe through which the water is conveyed into the pump house. The elevation of this pipe above the base of the dam is 17 feet, which leaves 13 feet of water available to the uses of the company, and this is the lowest point to which it is practicable to draw the supply.

The water of the lake, after passing through screens in the pipe chamber in the dam, enters the pump house through a 4-foot iron pipe. This pipe is surrounded by a brick arched culvert, of sufficient size to allow easy access to all parts, and connects with 2 large cast-iron tanks containing a series of gates. These tanks are again connected by cast-iron pipes with the two cast-iron fore bays, and also with the rear valve boxes of the pumps. From the forebays the water is conducted upon the wheels, through gates placed at various points, so that the surface water can be used upon the wheels, no matter what its elevation may be.

There are 2 pitch-back wheels 30 feet in diameter, constructed of wood and iron. The

buckets are 6 feet long, and of wrought iron, 80 in each wheel. The wheel shafts are 14 inches, and their bearings 12 inches in diameter. The power is communicated by a driving wheel to a pinion on the crank shaft, giving to the pump piston a stroke of five feet. The 2 crank shafts are furnished with a coupling, by means of which either pump can be worked by either wheel, or one pump by both wheels.

The pumps consist each of a single cylinder 16 inches in diameter. The ordinary velocity at which they are worked is 12 strokes per minute, delivering 1,000 gallons. The speed may be increased with safety so as to deliver 1,500 gallons per minute. From the pumps the water passes through the force main, of cast iron, 16 inches in diameter, and 3,100 feet long. The force main contains 2 check valves, one at an elevation of 80 feet, and the other near the reservoir.

The reservoir, situated on Sachem's Hill, at an elevation of 125 feet above mean high water, is in the form of an ellipse, whose diameters at the water line are 488 and 244 feet, with a depth of 19 feet, the walls being carried up 4 feet above the water line. Its capacity is 10,000,000 gallons. It is built in two divisions. The bottom and inner slopes are covered with 18 inches of clay puddle; upon this is placed a layer of concrete 4 inches thick. The concrete on the sides is protected by a stone wall 12 in. thick, laid in cement. The outer slopes are turfed. The slope wall is covered by a coping 2 feet wide, and upon the top of the banks is a gravelled walk 6 feet wide. The whole width at top is 10 feet. The inner slopes 1 to 1, and the outer slopes  $1\frac{1}{2}$  to 1. At the east end of the division bank is placed the influent chamber, which consists of two apartments. The water is delivered by the force main into one of these, which contains the screens; from thence it passes in pipes of cast iron, 12 inches in diameter, through the other apartment, which contains the gates into the reservoir, or by means of a wrought-iron and cement pipe 16 inches in diameter, into the effluent chamber. By the arrangement of these pipes and gates the flow of water is controlled and directed into either division of the reservoir, or into the effluent chamber, without passing through the reservoir, and a special casting, which may be placed in either chamber, so connects the force and distributing mains, that in the event of accident to both divisions of the reservoir and one of the chambers at the same time, the supply of water to the city will be uninterrupted.

The 16-inch distributing main connects with the effluent chamber; placed at the west end of the division bank, is a duplicate of the influent chamber, with the exception of its depth. This peculiar arrangement of chambers, pipes, and gates is very complete, and calculated to meet any emergency, providing amply for future enlargement of capacity, as well as for present use. It gives to the works when need-

ed 2 16-inch force tubes; 2 16-inch and 2 12-inch distributing mains. Upon the occurrence of fire, at a time when, from any cause whatever, the water in the reservoir is low, the full head of 129 feet may be given without delay.

One third of the distribution is in cast-iron pipes, and the remainder is of the cement pipes manufactured by the Patent Water and Gas Pipe Company, Jersey City, New Jersey. The pipes are made from sheet iron, lined on the inside with cement, and coated on the outside with the same material. The lengths of pipe are connected by sheet-iron bands, similarly lined and coated with cement; the bore of the pipe presents an even surface throughout the entire length of pipe, and forms a conduit of uniform size.

*New York Croton Aqueduct.*—Various improvements, under the charge of A. W. Craven, chief engineer, have now been in progress for a series of years to increase the average supply and to guard against any contingencies of accident to the aqueduct or failure of supply from the river.

*High Bridge Improvement.*—As originally constructed, the supply was conducted across High Bridge by 2 siphon pipes of 3 feet in diameter, involving great loss of head, and consequent capacity of aqueduct on this side of Harlem River, and of supply. To obviate this a new pipe has been introduced.

The new pipe is 7 feet 6 $\frac{1}{2}$  inches interior diameter. It is made of wrought-iron plates, each 8 ft. by 6 ft., and  $\frac{1}{4}$  an inch in thickness. These plates are butted together, and the joints made by horizontal and transverse straps on the outside, each strap being 9 inches in width and  $\frac{1}{4}$  of an inch in thickness. There are 4 rows of  $\frac{1}{2}$ -inch rivets in each strap. In the interior, the rivets are countersunk to the plane of the pipe, thus affording a smooth surface and avoiding unnecessary friction. Both the exterior and interior surfaces are well painted, to preserve them from rust. The pipe is supported by cast-iron stanchions and saddles, placed between the 2 8-foot pipes now there. These stanchions are 12 feet apart longitudinally, and are of sufficient height to allow 2 feet of clear space, between the old pipes and the new one, for the free movement of workmen in repairs, &c. The tops of the stanchions or pedestals are 2 $\frac{1}{4}$  feet square, and are planed to a smooth and accurate surface, to permit the proper action of the rollers. At the centre of the bridge, the pipe rests upon the pedestal, without the intervention of rollers. For the rest of its length, in each direction from the centre, there are 3 cast-iron rollers on each stanchion. Upon these rollers rest the saddles, which come into immediate contact with and support the pipe itself. The base of each saddle is of the same size as the top of the pedestal, and is in a similar manner planed to a smooth and uniform surface.

At each end of the bridge, and built into the

masonry connecting the pipe with the gate-house, there is a cast-iron cylinder, into which a cast-iron ring, which forms the end of the pipe, is inserted and fitted as a piston. Thus there is a movable joint at each end of the pipe, which, together with the rollers between the planed surfaces of the pedestals and saddles, fully provide for the longitudinal contraction and expansion of the pipe, under any variations of temperature to which it can be subjected. The three rollers on each pedestal are kept in their proper relative position to each other by an iron frame. The surfaces of contact in the pistons and cylinders, at the ends of the pipe, are faced with brass.

Fig. 3 represents a vertical and transverse section of the bridge, at the centre of one of the arches. It shows the former construction of the top of the bridge and the line of the former gravel covering over the pipes, and also shows the contemplated change in the sides and the proposed covering arch. All the masonry above the line of the old coping, and all the interior brick work, above the points marked A A, will be new work. When finished, the whole interior will be an open chamber, with sufficient space around all of the pipes for examination and repair. This chamber will be lighted and ventilated from the roof, and approached by doors, cut into the masonry at the sides of the north end of the bridge, which will be large enough to admit the introduction of cast-iron pipe or wrought-iron plate, or any other material for repairs. The roof will be of brick, abutting against cast-iron skew backs, kept in place by wrought-iron tie-rods. The arch will be made water tight by a covering of concrete and asphaltum.

To keep up the supply of water to the city during the progress of the work in connecting the new pipe, it was necessary to change the entrance gates of the old pipes, from the front to the side of each gate chamber, and to do this, also, without drawing off the water from the aqueduct and gate chambers. A caisson or coffer dam of wood was framed and sunk to its position, against the inner face of the west wall of each chamber, leaving a narrow space between the masonry and the inner face of the coffer dam. The water from this space was then pumped out. The west walls were then cut away and rebuilt, with the proper variation for new gates, and the reception of the mouth pieces for the two 8-foot pipes. From these points, two new lines of pipes were carried round, on the outside of the gate houses, and down to the floor of the bridge, to the point at which the re-

moval of the old pipes was necessary. Here the pipes were, one at a time, cut off, and connected with the new lines leading into the side of the gate house. The water was then passed through the old pipes by these new connections, and the fronts of the gate houses were free for further operations. The masonry of almost the entire fronts (below the water line) was removed in the same manner it had been from the sides, and the new construction went on without interruption. During the whole of this work, there was at no time a stoppage of the entire flow of water into the city. It was not shut off at all, for any of the operations, at the gate-chambers themselves.

*Manhattan Valley Improvements.*—At this valley there is an interruption of the brick conduit similar to that at High Bridge. As originally constructed, the water was conducted across this valley in 2 3-ft. siphon pipes, to which was added, in 1853, a 4-ft. pipe. This year a fourth pipe has been added, 5 feet diam., of cast iron, in lengths of 12 ft. 5 in., and 1½ inches in thickness. The average

FIG. 3.

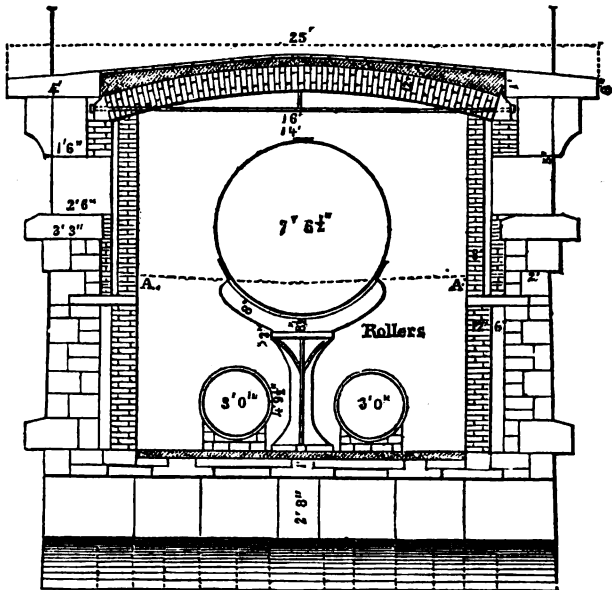

weight of each length is 11,226 lbs., and the aggregate extent of this line, measured as laid, is 4,116 ft.

*The New Reservoir.*—The water was formally introduced into the new reservoir on the 19th of August, with a celebration by the civic authorities, and speeches from the mayor (Mr. Opdyke), and from Myndert Van Schaick, for many years president of the Croton board, and from many others. The reservoir is probably the largest purely artificial construction in the world. Its water surface, when full, is 96 acres, its depth 87 ft., and its capacity

1,039,000,000 N. Y. galls. It has been built on the most substantial plan and in the most careful and skilful manner possible. The puddle trench is carried down to and founded on the solid rock throughout its entire circuit. The interior slopes are protected by a facing of hydraulic masonry.

There are three gate houses. The first of these gate houses is that by means of which the water is taken out of the old aqueduct, at the corner of 9th av. and 92nd st. The old aqueduct has been opened for the space of 46 feet, and a chamber built, combining two sets of gates—one set permitting the water to pursue its old course through the old aqueduct to the present receiving reservoir at 85th st., and the other set diverting the water into the new junction aqueduct, which leads to the new reservoir. There are 5 gates to each channel, so arranged that all the water can be passed either into the old or new reservoir at pleasure, or a portion sent to each. From this junction gate house to the north gate house of the new reservoir, the aqueduct is 2,629 feet in length, and similar, in the form of its sectional area, to the old aqueduct. In order to carry this structure across the 9th av. and through 92nd st., without interfering with their grades, it was necessary to place it about 7 ft. below the regular level of the old aqueduct. When, therefore, the old aqueduct runs full, there will be a pressure on the top of the new one, due to that height. The masonry has been accordingly strengthened to meet this pressure.

The junction aqueduct terminates at the north gate house of the reservoir. This gate house, situated at the north end of the central or dividing bank of the reservoir, serves the double purpose of an inlet and an outlet gate house. The water is received into an induction chamber, which is furnished with 2 sets of gates, 5 in each set. Through these gates the water is discharged immediately into either or both of the divisions of the reservoir, at pleasure. Directly below the induction chamber are the inlet channels from the 2 divisions of the reservoir to the fore bays, which are the entrances to that portion of the gate house which is arranged for the discharge of the water into the city. These fore bays are divided into spaces 7 ft. in width by 12 ft. in length. The fore bays are built of granite. In front of the gates which let the water into the main outlet chambers, grooves are cut in the sides of the fore bays for a double set of screens of copper wire gauze, and for the insertion of temporary coffer dams, should they ever be required. Beyond the gates is the back bay, into which water passes from both divisions of the reservoir. This back bay is so arranged, however, that the whole of it can be filled with water from either division at pleasure. And, again, it can be divided in itself, so as to use but one portion of it at a time, should it be necessary. The rear wall

of the back bay separates that portion of the gate houses into which the water flows from the portion of it called the pipe vault. In this wall are inserted the mouths of the outlet pipes. In the pipe vault beyond, and through which the pipes pass into the city, are the stop cocks controlling the pipes and other arrangements for division and shutting off water, should repairs to the stop cocks or pipes be required. The vault is entered from the top of the bank by a circular staircase, through a well large enough to admit the lowering of pipe, or stop cocks, or other material. Underneath the whole of this structure passes the main sewer, to receive the overfall of water from the waste weir, which is also included in the general plan of the gate houses.

Passing under the floor of the gate house, there is also a pipe, 3 ft. in diameter, leading from each division of the reservoir to the main sewer, at a point beyond the pipe vault. These pipes are not in any wise connected with the distribution pipes, but are intended only to draw off the water from either division, when necessary. 4 distribution pipes lead from this gate house to the upper part of the city, each 3 feet in diameter.

The south gate house is situated at the south end of the bank dividing the reservoir. It is arranged only for distribution, and has, therefore, no induction chamber for the purpose of delivering water into the reservoir. In all other respects it is similar in design and character of work to the north gate house, except that it has 6, instead of 4, outlet or distribution pipes, each of which is 4 ft. in diameter.

Both gate houses are built on the natural solid rock. The outer exposed walls and the sides of the fore bays, the openings for the gateways, screens, &c., the wells for the waste weirs and their approaches, the mouth pieces to the pipes, and the braces in the fore bays, are of granite. The walls under the banks are of gneiss and brick, the other face walls and arches are of brick, while the foundations and the interior of the walls are of concrete. The tops of all the walls of the gate houses are covered with a floor of granite 1 ft. in thickness. On this floor will be placed the gearing for working the gates below, a vertical distance of 44 ft. The gates and gate frames are of cast iron, with the sliding parts faced with brass. There are upper and lower sets of gates, by which a circulation in the water can be effected, and which at the same time will facilitate other operations. With a view to provide for every possible contingency, there is no portion of the whole work which cannot be examined and repaired without shutting off the water from the city for a moment.

There are now 5 main pipes supplying the city from the old receiving reservoir, as follows: 1, 2½ ft. in diam., from the west side of the reservoir, passing down 8th av.; 1, 2½ ft. in diam., from the east side, passing down 3d av.; 2, each 3 ft. in diam., passing down the 5th

av., and 1 pipe, 8 ft. in diam. where it leaves the reservoir (but connected with the four-foot pipe immediately after), passing down the 4th avenue.

With these five pipes a corresponding number of the effluent or distributing pipes from the south gate house of the new reservoir are to be connected; so that, when this is done, the whole water distribution of the city can be supplied from both, or either of the reservoirs, at pleasure; and, so far as the new reservoir is concerned, with either division of it, as any emergency may require.

INTEREST ON CROTON DEBT.  
Payable from Sinking Fund.

Amount in 1859.....	\$512,193 85
" 1860.....	447,901 39
1861.....	476,404 29
	\$1,436,502 03

CROTON WATER RENT.

Income from	1859.	1860.	1861.
Water Registrar.....	\$759,250 65	\$767,169 62	\$765,954 35
Receiver of Taxes....	30,708 39	22,850 02	22,861 02
Clerk of Arrears.....	81,546 95	32,901 17	20,840 53
	\$821,505 99	\$822,920 81	\$809,656 50
	822,920 81		
	809,656 50		
	\$2,454,083 30		
	1,436,502 03		
Surplus.....	\$1,017,581 27		

Present debt, December 31, 1861.....\$9,917,605 00

This statement shows that in three years the Croton revenue paid into the sinking fund nearly two and a half millions of dollars, and the sinking fund paid the interest on the then existing Croton debt of nearly one and a half millions of dollars, leaving \$1,017,581.27 surplus; and that the present Croton debt is only \$9,917,605, notwithstanding the very large aggregations of expenditures on improvements and repairs of the works which make the opinion credible, that the total amount of expenditures on the works exceeds \$24,000,000, though the aqueduct and its dependencies cost originally, according to engineer Jarvis' last report, only \$9,000,000.

PHILADELPHIA.—From early summer until about the middle of November, there was not sufficient water in the River Schuylkill, except at limited intervals, to drive the machinery at the old Fairmount Works. During this period, it has been only with the unremitting operation of the engines and pumps at their fullest capacity that the Kensington Spring Garden, and Twenty-fourth Ward Works have been enabled to supply their districts; and even then not always successfully, nor adequate to the demands of the population. Generally, there is no difficulty in furnishing a full supply to the entire city during seven months of the year, with the works and facilities at present in operation. But this is the utmost extent of their entire reliability, and during the warmer months, it is not without difficulty that an adequate supply can be maintained in any year.

*The Fairmount Works.*—The 8 old wooden wheels and their pumps were originally designed and intended to raise the water to an elevation of about 96 feet, and such was the service performed by them satisfactorily for some years after their completion; but, since the construction of the Corinthian Avenue Reservoir, making an additional altitude of 27 feet above that of the reservoirs, as designed in the original plan of the works, these pumps have frequently been much overworked.

On the security of the dam at Fairmount depends the entire ability of the Fairmount, Spring Garden, and Twenty-fourth Ward Works to supply their respective districts.

The new wheel house and machinery are completed, and the new pumps have been in operation at intervals since the month of June last, and work satisfactorily, but they cannot become fully available until the capacity of the ascending main is increased to a degree better corresponding to the area of the pumps. The six new pumps are each of 18 inches diameter, and the number of gallons pumped during the year was 3,564,724,753; average number of gallons raised per day was 9,766,369.

The engines and pumps at the *Spring Garden Works*, with one exception, are much worn, and their efficiency much impaired by constant and frequently excessive service, almost without interruption from the time of their construction. In 1862, Nos. 1, 2, and 3 pumped 1,897,391,860 gallons, and the Cornish engine, No. 4, pumped 1,141,136,060 gallons. In the performance of this work, the former three engines consumed 5,777,571 lbs. of coal, and the latter one engine consumed 2,547,161 lbs., and the number of gallons of water pumped during the year was 3,038,527,420; average number of gallons per day was 8,324,782. Average duty for the year, 32,993,838 pounds raised one foot high with 100 lbs. coal. Total amount of coal consumed by engines, 8,895,459 lbs.

The *Kensington Works* draw their supply from the Delaware. Such is the demand upon them that if it is decided that they shall be continued, it will be soon necessary to have an additional ascending main, of such capacity as to anticipate, at least in some measure, the greater demand that must arise. There are at present at these works two engines, one of which is a condensing engine, driving a pump of 19 inches diameter; the other is a non-condensing engine, driving a pump of 18 inches diameter. The single ascending main is 13,300 feet long, and 18 inches in diameter, being capable of carrying the water from one pump only. During the warm season, more water is required in the district than this one main can safely supply. The average maximum capacity of the pumps is rated at 3,000,000 gallons each per twenty-four hours. The daily demand has reached as high as 3,780,290 gallons, and the least demand in any day of the past year was 2,954,770 gallons, and the number of gallons of water pumped during the year was 909,126,-



440; average number of gallons pumped per day, 2,490,757.

Average duty for the year, 22,778,365 pounds raised one foot high by the consumption of 100 lbs. of anthracite coal. Total amount of coal consumed by engines, 1,662 tons 4 cwt. 1 qr.

Such is the rapid increase in the demand in the district supplied by the *Twenty-fourth Ward Works* that it is difficult to provide for it satisfactorily. On account of there being no reservoir, nor any other facilities for storage, and the fact that there is only one main from the works to the stand-pipe, the demand is supplied directly from the pumps, and requires the constant and unremitting operation of one engine, the other being kept in constant readiness in case of accidents. The number of gallons pumped during the year was 420,507,810; average number of gallons raised per day, 1,152,076.

Average duty for the year, 88,525,000 pounds raised one foot high by the consumption of 100 pounds of anthracite coal. Total amount of coal consumed by engines was 938 tons 18 cwt. 19 lbs.

Number of gallons pumped by all the works during the year, 7,932,886,423. Average number of gallons pumped each day, 21,738,935.

WINDISCHGRATZ, ALFRED ZU PRINCE, formerly commander-in-chief of the Austrian armies, born in Brussels, May 11, 1787, died at Vienna, March 24, 1862. He entered the military service in 1804, received the command of the Cuirassiers of the Grand Duke of Constantine for his brilliant conduct at Leipsic, and distinguished himself during the campaign of 1814 at Troyes. He was promoted to be major-general in 1826, and made general of division and lieutenant field marshal in 1838. In 1848 he led the armies which bombarded Prague, Pesth, and the Austrian capital in succession, but meeting with reverses in Hungary he was driven from Buda-Pesth in 1849 by Görgey, and in April of that year was deprived of his command. Fierce and cruel, he never treated the Hungarians with the least leniency, and his latter days were saddened by seeing the principles against which he had fought so obstinately, carried out, at least partially, by the Government. On one occasion, during the first session of the Reichsrath, he ascended the tribune of the Upper Chamber, and prophesied new catastrophes, the necessary consequence, he said, of the statute of February, and announced his readiness to protect Austria as heretofore with his sword, but meeting with no response he retired henceforth to private life. In 1851 he published a work defending his conduct in the Hungarian campaign entitled "*Der Winterfeldzug Von 1848-'9 in Ungaru.*"

WISCONSIN, one of the most thriving Northwestern States, increased in population during the ten years ending June, 1860, 470,490, when the whole population was 775,881. (See UNITED STATES.)

The Governor of the State, Harvey, was in-

augurated on the 1st of January, 1862. He had been elected by the Republican voters on the first Thursday of November, 1861, by a majority of 8,820 over the Democratic candidate.

The Legislature convened on the 9th of January. The members of the Assembly and half of the Senate had been elected in November previous, and were divided as follows:

	Senate.	House.
Republicans.....	22	43
Democrats.....	11	34
Union.....	—	23

The governor in his message recommended economy in the expenditures, the introduction of military drill in public schools, and the establishment of an armory and arsenal at Milwaukee, on the Lake Michigan.

The following resolutions expressive of the views of the majority of the Legislature on Federal affairs were adopted with seven dissenting votes in the House and nine in the Senate:

*Whereas*, The language of joint resolution number 4, adopted by the Legislature of 1859, is in some of its parts identical with those of the Kentucky resolutions of 1798;

*And whereas* such language is liable to be so misconstrued and perverted as to lead to misapprehension of the purpose of its adoption, and to favor secession;

*And whereas* there is evidence in the fact of such Kentucky resolutions having been endorsed by and incorporated into and made part of several of the Democratic national and State platforms, and especially by that recently promulgated by the Democratic State Convention of Indiana, that the true intent and meaning of such language has been misconstrued and perverted; therefore,

*Resolved by the Assembly, the Senate concurring*, That we regard the action of the rebellious States of this Government, in their attempt to destroy the Union by the pretended lawful right of secession, as unwarranted by the spirit of the Constitution, and utterly subversive of the well-established principles of good government.

*Resolved*, That no State of this Union has a right to defy or resist the laws of the Federal Government, but should yield a willing and hearty support to the enforcement of the laws, unless such laws are unjust or deleterious in their operation, in which case the only rightful remedy lies in their repeal or lawful abrogation.

*Resolved*, That joint resolution number 4, of the Legislature of Wisconsin of the year 1859, in theory enunciates the dangerous doctrine of nullification and resistance to the lawfully constituted authority of the Federal Government, and is incompatible with the safety and perpetuity of the Union.

*Resolved*, That said joint resolution number 4, of the Legislature of this State of the year 1859, entitled "Joint resolution relative to the decision of the Supreme Court of Wisconsin," be and the same is hereby repealed.

On the 5th of April a resolution passed the House with one dissenting vote tendering to the President of the United States an unqualified approval of his course from the day of his inauguration.

A bill was brought before the Legislature at this session to repeal the "Personal Liberty" law of the State. But no final action was taken upon it until the extra session in July, when it was passed, and the law repealed. (See ANNUAL CYCLOPEDIA, 1861 — PERSONAL

**LIBERTY LAWS.)** This was the first instance among the Western States of the repeal of these obnoxious laws. At this same extra session resolutions were passed by a majority of fourteen which emphatically condemned all future anti-slavery agitation in the Northern States.

On the 19th of April, Governor Harvey was drowned at Savannah, in Tennessee, whither he had gone with hospital stores for the soldiers of the State who were wounded at the battle of Shiloh. He was succeeded by the lieutenant governor, Edward Salomon, a German-born citizen.

An election for six members of Congress took place on the first Thursday of November, when the votes were given as follows:

	Republican.	Democratic.
1st District.....	10,077	12,598
2d " .....	18,107	10,974
3d " .....	10,000	7,514
4th " .....	9,613	15,848
5th " .....	10,005	11,021
6th " .....	9,087	6,672

The Democratic candidates were elected in the 1st, 4th and 5th districts, and Republican candidates in the 2d, 3d and 6th districts.

The debt of the State previous to the war was \$100,000. A loan for war purposes was authorized by the Legislature in extra session, May, 1861, of one million dollars. Of this loan \$800,000 was taken by the bankers of the State, who paid 70 per cent. at once, and the balance in instalments of 1 per cent. every six months, giving their personal bonds as security for the payment, and depositing the State bonds with the Bank Comptroller as a basis for banking in place of the depreciated bonds of Southern States.

The number of banks in the State in May, 1862, was seventy, whose capital was \$4,397,000; specie, \$380,000; circulation, \$4,600,000.

The length of the railroads in the State is 1,157 miles, cost \$41,809,817.

There are nine colleges in the State, three theological seminaries, and a medical school. The number of common school districts is 4,558, and the number of children in attendance at the schools is 198,448, besides 8,000 estimated to be in attendance at private schools. The school fund of the State is derived from the proceeds of the sale of the sixteenth section of each township and an additional grant by Congress of 500,000 acres of land; 25 per cent. of the proceeds of sale of swamp and overflowed lands, and lands selected in lieu thereof (25 per cent. goes to the Normal School Fund); 5 per cent. of the proceeds of sales of Government public lands in the State (this has been withheld in consequence of a claim of Government against the State); 5 per cent. penalty as forfeiture for non-payment of interest on school land certificates and school fund loans; and the clear proceeds of all fines collected in the several counties for penal offences and for trespasses on State lands. The productive fund from the sale of these lands, &c., September 30, 1861,

was \$2,458,851 49, and there remained unsold and forfeited 454,775 acres of sixteenth section lands; forfeited lands of 1861, 219,000 acres; 125,000 acres unsold swamp lands; 118,750 acres of forfeited swamp lands; and 39,500 acres of forfeited swamp lands of 1861. There are also 140,000 acres of land claimed from Government, and sixteenth section and swamp land, yet unsurveyed. The lands as yet unsold will exceed 1,500,000 acres.

Previous to the 1st of July, 1862, the State had sent to the war nineteen regiments of infantry, three regiments of cavalry, and seven batteries of artillery and two companies of sharpshooters—numbering entire 24,658 men. Under the call for 300,000 men in July, six regiments were raised, and under the call for 300,000 nine months men about twelve regiments more. The attempts to complete the quota under the first call by drafting met with much opposition in some parts of the State. At Port Washington, in Ozaukee county, the commissioner was forced to flee for his life, the machinery for the draft was destroyed, and the houses of eight citizens who encouraged the draft were attacked and injured. A military detachment was sent to restore order. In Washington county serious disturbances occurred.

WOLFF, JOSEPH, D. D. LL.D., a traveller, author and clergyman of the Church of England; born at Weilersback, near Bamberg, Germany, in 1795; died at the vicarage, Isle Brewers, Somersetshire, England, May 2, 1862. He was the son of a Jewish rabbi, named David, and received the name Wolf from his parents, to which he prefixed "Joseph" when he became a Christian. While yet a child he manifested so strong a predilection for Christianity that the Jewish neighbors called him "the little Nazarene." At the age of 17, through the influence of Count Stolberg and Bishop Zeiler, he embraced the Roman Catholic faith, and was baptized by Leopold Zolder, a Benedictine abbot, near Prague, September 18, 1812. The next year he commenced the study of Arabic, Syriac and Chaldean, and the following year attended theological lectures in Vienna, enjoying the friendship of Profs. John, Friedrich, Von Schlegel, Werner, and Hofbauer, the General of the Redemptorist fathers. From 1814 to 1816 he studied at Tubingen, being supported by Prince Dalberg. His attention was here given to the study of the Oriental languages, for which he possessed a Jewish aptitude, together with ecclesiastical history and Biblical exegesis, under Professors Stendell, Schnurrer, and Flatt. He next travelled for a year in Switzerland and Italy, enjoying the society of Madame de Staël, Holstein, the historian, Niebuhr, Zschokke, Madame Kürdener and others. Toward the close of the same year, he was first received as a pupil of the Collegio Romano at Rome, and afterward transferred to the College of the Propaganda; but his spirit was too restless and dogmatic to accept without questioning all the teachings of

the Propagandist fathers, and in 1818 his religious views were declared erroneous, and he was expelled from Rome. He returned to Vienna, where, after consultation with F. Von Schlegel, Dr. Emanuel Veit, and Hofbauer, he entered the monastery of the Redemptorists at Val-Saint, near Fribourg; but his nature rebelled against unquestioning acquiescence in the theological *dicta* of the fathers, and after a few months he left Val-Saint and came to London, where he found the late Henry Drummond, M. P., whose acquaintance he had formed at Rome. He soon avowed his conversion to Protestantism, and, at Mr. Drummond's suggestion, went to Cambridge, and continued his Oriental studies under Prof. Lee, and also commenced a course of theological studies under the late Rev. Charles Simeon. In 1821, he set out for a tour in the East for the purpose of proclaiming the Gospel to Jews, Mohammedans, and Pagans, and ascertaining the condition of the Eastern Christians with a view to missionary labor among them. In this tour, which occupied him for five years, he visited Egypt, Mount Horeb, Mount Sinai, and Jerusalem, distributing copies of the Scriptures, and in his peculiar way discussing the merits of the Scriptures with all controversialists. He was at first supported by some of the charitable societies, but as his erratic habits occasioned some fault-finding, his friend Drummond after a time sustained him at his own expense. In 1826 he returned to England, and formed the acquaintance of Lady Georgiana Mary Walpole, daughter of the second Earl of Orford, whom he married in 1827, and with whom he set out almost immediately on a second missionary tour, visiting Malta, where his wife remained awaiting his return from Smyrna, the Ionian Islands, and Jerusalem, where he was poisoned by some bigoted Jews, and nearly lost his life. He returned, on his recovery, to Constantinople, where his wife met him, and soon set out again from that city for Bokhara, to search for the remains of the ten tribes. On his route he encountered the plague, was taken prisoner and sold as a slave, but was redeemed by the Persian Minister, Abbas Mirza. He resided at Bokhara for three months, preaching to his countrymen, and then set out for India by way of Khorassan. On his route he fell into the hands of the Kharijee, a robber tribe, who stripped him of everything he possessed, and to escape from them he made his way on foot and nearly naked through the mountain passes to Cabool, a distance of 600 miles. Finding friends at Cabool, he went on through the Punjab, Lahore, Loodiana, and Simlah to Calcutta, preaching on his way at 180 stations. At Calcutta he was the guest of the governor general. From Calcutta he went to Masulipatam and Madras, and near the latter city was seized

with cholera. On his recovery he visited Pondicherry, Tinnevely, Goa, and Cochin China, visiting the Jews of those regions, and Bombay, and sailed from thence for Arabia, whence he crossed into Abyssinia, acquired the Amharic language, and in 1834 returned to England *via* Malta. In January, 1836, he visited Abyssinia again, and finding Bishop Gobat sick at Axum, brought him to Jiddah, and returned to Abyssinia, where the natives worshipped him as their new *abouna*, or patriarch. Leaving them he crossed into Arabia, visited the Rechabites in Yemen, and met a party of Wahabites in the mountains of Arabia, who horsewhipped him, because they could find nothing in the Arabic Bible, he had given them about Mohammed. Escaping from their hands, he sailed in the beginning of 1837 for Bombay, and thence for New York, where he arrived in August, 1837. While in the United States he was ordained deacon by Bishop Doane, visited the principal cities, preached before Congress, received the degree of D. D., and in January, 1838, sailed for England. He next visited Dublin, where he received priest's orders from the Bishop of Dromore, and settled as curate first at Southwaite and afterward at High Hoyland, in Yorkshire. In 1843, the news of the imprisonment of Col. Stoddart and Capt. Conolly (the latter a personal friend of Wolff, and one who had rendered him great service in one of his tours) reached England, and Dr. Wolff offered to attempt their release, or learn their fate. The British Government declined to send him officially, but individuals furnished the means, and he went out, passing through Persia in full clerical dress, with a Bible in his hand, and announcing himself as "Joseph Wolff, the grand dervish of England, Scotland, and Ireland, and of the whole of Europe and America," and reached Bokhara in safety, having learned, however, before arriving at that city that Stoddart and Conolly had been beheaded. At Bokhara he was made a prisoner by the emir who had put the English officers to death, and a day fixed for his execution; but the Persian ambassador interfered, and he made his escape, and was enabled to avoid the assassins who were sent after him by the emir. On his return to England he was presented to the vicarage of Isle Brewers, where he resided till his death, and by his persistent efforts succeeded in erecting a neat and commodious church. Lady Georgiana died January 16, 1859, and in May, 1861, he married a second wife, who survives him. Dr. Wolff was the author of the following works: "Journal of Missionary Labors," 1839; "Mission to Bokhara," 1846; "Missionary Labors and Researches," 1854; and "Travels and Adventures of Rev. Joseph Wolff, D. D., LL.D., 1860-61.

## INDEX OF SUBJECTS.

	PAGE		PAGE
AFRICA .....	1	DELAWARE .....	373
AGRICULTURE .....	4	DIPLOMATIC CORRESPONDENCE .....	373
ALABAMA .....	8	DRURY'S BLUFF, VA. ....	398
ARGENTINE REPUBLIC .....	10	EARTH .....	398
ARKANSAS .....	10	EDUCATION .....	395
ARMY, CONFEDERATE .....	19	ELECTRICITY .....	409
ARMY OF THE UNITED STATES .....	16	ELLET, CHARLES, JR. ....	412
ARMY OPERATIONS .....	24	EXHIBITION, BRITISH INDUSTRIAL .....	412
ASTRONOMICAL PHENOMENA AND PROGRESS, .....	173	FAYETTEVILLE, ARKANSAS .....	451
AUROEAS .....	177	FELTON, CORNELIUS C. ....	452
AUSTRIA .....	181	FERNANDINA, FLA. ....	452
BALLOONING .....	184	FINANCES OF THE UNITED STATES .....	452
BAPTISTS .....	187	FLORIDA .....	474
BAROMETER .....	189	FRANCE .....	475
BATESVILLE .....	191	FREDERICK, MD. ....	479
BATON ROUGE .....	191	FREDERICKSBURG, VA. ....	479
BEAUFORT .....	191	FREEDOM OF THE PRESS .....	490
BECKWITH, JOHN CHARLES .....	191	FRELINGHUYSEN, THEODORE .....	481
BERESFORD, JOHN GEORGE .....	192	FRONT ROYAL, VA. ....	481
BETHUNE, GEORGE W. ....	192	GEOGRAPHICAL AND ARCHÆOLOGICAL EX- PLORATIONS .....	481
BLOCKADE .....	193	GEORGIA .....	493
BRAZIL .....	197	GREAT BRITAIN .....	496
BRODIE, BENJAMIN C. ....	200	GREAT EASTERN, STEAMSHIP .....	501
BUCKLE, HENRY THOMAS .....	200	GREECE .....	506
BUILDING MATERIALS .....	201	HABEAS CORPUS .....	508
CALIFORNIA .....	206	HARRISONBURG, VA. ....	516
CANNING, CHARLES J. ....	206	HOGG, THOMAS J. ....	516
CHEMISTRY .....	208	HOLLY SPRINGS, MISS. ....	516
CHILL .....	222	HOPE, FREDERICK WILLIAM .....	516
COCHIN-CHINA .....	223	HORNE, THOMAS H. ....	517
COLT, SAMUEL .....	225	HUNTSVILLE, ALA. ....	517
COMMERCE .....	227	ILLINOIS .....	518
CONFEDERATE STATES .....	235	ILLUMINATION .....	520
CONGREGATIONALISTS .....	235	INDIANA .....	526
CONGRESS, CONFEDERATE .....	236	INGERSOLL, CHARLES J. ....	529
CONGRESS, UNITED STATES .....	275	INSURANCE .....	529
CONNECTICUT .....	276	IOWA .....	524
DECATUR, ALABAMA .....	278		

	PAGE		PAGE
ITALY.....	585	OBITUARIES, FOREIGN.....	698
JOHNSTON, ALBERT SIDNEY.....	588	OHIO.....	695
KANSAS.....	589	OREGON.....	698
KEARNY, PHILIP.....	540	PASQUIER, ETIENNE DENIS.....	699
KENTUCKY.....	540	PATENTS.....	699
KNOWLES, JAMES SHERIDAN.....	548	PENNSYLVANIA.....	708
LANDER, FREDERICK WILLIAM.....	548	PRESBYTERIANS.....	707
LITERATURE AND LITERARY PROGRESS IN 1862.....	544	PRISONERS, EXCHANGE OF.....	710
LOUISIANA.....	552	PROTESTANT EPISCOPAL CHURCH.....	717
LUTHERANS.....	554	PUBLIC DOCUMENTS.....	739
MACKENZIE, BISHOP.....	557	REFORMED CHURCHES.....	743
MAINE.....	557	RHODE ISLAND.....	744
MARYLAND.....	559	RICHARDSON, ISRAEL B.....	746
MASSACHUSETTS.....	561	ROMAN CATHOLICS.....	746
MCCULLOCH, BEN.....	566	ROSS, JAMES CLARK.....	749
McNAB, ALLAN N.....	566	RUSSIA.....	749
MEADE, WILLIAM.....	566	SAN MIGUEL, EVARISTO.....	751
MEMPHIS.....	567	SLAVES.....	752
METEOROLOGY.....	570	SMITH, CHARLES FERGUSON.....	758
METHODISTS.....	579	SOUTH CAROLINA.....	759
MEXICO.....	588	STEVENS, ISAAC INGALLS.....	760
MICHIGAN.....	585	SUMNER, JOHN BIRD.....	760
MINNESOTA.....	586	TAE-PING REBELLION.....	761
MISSISSIPPI.....	588	TENNESSEE.....	763
MISSOURI.....	589	TERRITORIES OF THE UNITED STATES.....	769
MITCHEL, ORMSBY M.....	595	TEXAS.....	773
NASHVILLE.....	596	TWIGGS, DAVID EMANUEL.....	775
NAVY, CONFEDERATE.....	599	TYLER, JOHN.....	775
NAVY, UNITED STATES.....	604	UHLAND, JOHANN LUDWIG.....	776
NAVY, UNITED STATES, OPERATIONS OF.....	629	UNITED STATES.....	776
NELSON, WILLIAM.....	640	VAN BUREN, MARTIN.....	796
NESSELRODE, CARL ROBERT VON.....	641	VERMONT.....	797
NEW HAMPSHIRE.....	641	VIRGINIA.....	798
NEW JERSEY.....	643	VIRGINIA, WESTERN.....	800
NEW ORLEANS.....	645	WAKLEY, THOMAS.....	803
NEW YORK.....	654	WATER WORKS.....	808
NORTH CAROLINA.....	660	WINDISCHGRATZ, ALFRED ZU.....	813
OBITUARIES, AMERICAN.....	662	WISCONSIN.....	813
		WOLFF, JOSEPH.....	813

## INDEX OF CONTENTS.

*Africa*, its political divisions, 1; explorations in, 2; affairs in Morocco, 2; Egypt, its internal affairs, 2; the ship canal at Suez, 3; Abyssinia, 3; Madagascar, 3; Zulu country, 3; Bight of Benin, 3; Liberia, 4; its cotton culture, 4.

*Agriculture*.—Crops of the Northern States, 4; short crop of western Europe, 4; exports of grain from the United States, 4; prices, 5; measures of Congress affecting agriculture, 5; agricultural college act, 5; agricultural department, 5; colleges of Michigan, Iowa, Pennsylvania, 6; studies at Pennsylvania College, 6; uses of machinery in agriculture, 7; fruit culture, 7; experience of fruit-growers, 7; favorite apples, 7; do. in different parts of the country, 7; do. pears, 8; grapes, 8; varieties, 8.

*Alabama*.—Increase of population, 8; other census statistics, 8; cotton at Mobile in 1861-'2, 8; mineral treasures, 9; orders of the governor to burn cotton, 9; appeal to the people for shot guns, 9; militia ordered out, 9; soldiers sent to the war, 9; advance of Gen. Mitchell into, 9; other expeditions into, 10; Confederate tax, 10.

*AMES*, Rev. Bishop, appointed commissioner to negotiate exchange of prisoners, 710.

*Argentine Republic*.—Situation, 10; boundaries, 10; government, 10; parties, 10; political divisions of the country, 10; population, 10.

*Arkansas*.—Census statistics, 10; military movements in, 11; poisoning of wells, 11; appeal of the governor to the people, 11; martial law, 11; skirmish near Searcy, 11; military governor appointed, 12; State election, 12; manufactures, 12.

*Army, Confederate*.—White male population of the Confederate States, 12; estimate of soldiers between eighteen and thirty-five years of age, 12; do. Confederate estimate, 12; volunteers in 1861, 13; quota, 13; another call for troops, 13; conscription law, 13; number obtained under it, 13; list of officers of the Confederate army, 13; condition of the troops in November, 1862, 14; appeal of the Governor of North Carolina for clothes and shoes, 15; straggling from the army, 16.

*Army, United States*.—Policy of the Government, 16; regular army, historical sketch of, 16; officers of each grade in 1862, 16; militia force, 17; how organized, 17; volunteers, 17; various calls for by the President, 18; number actually raised, 18; monthly pay of non-commissioned officers and privates, 18; pay and commissions allowed to officers, 19; materials for equipment of such a vast force, how obtained, 20; sanitary condition, 20; mortal-

ity, 20; proportion sick, 21; absentees, 21; orders to provost marshals to arrest them, 21; surgical department, 21; subsistence department, 21; ordnance department, issues of, 21; list of officers in the regular and volunteer service, 22, 23; casualties, 23.

*Army Operations*.—Number and position of the Federal forces, January, 1862, 24; number and positions of Confederate forces, January, 1862, 24; results of the previous year, 24; what required to organize and equip the Federal army, 25; plans of the Government for the war, 25; influence of railroads on military operations, 25; movements in Kentucky, 25; object of the Confederate officers, 25; defeat of Humphrey Marshall, 25; despatches of Col. Garfield, 25, 26; proclamation of Gen. Crittenden, 26; position at Mill Spring, 26; movements of Gen. Thomas, 27; defeat of Gen. Zollicoffer, 27; forces on each side, 27; thanks of the Government, 27; effect of the victory at the North, 27.

Reconnoissances in Kentucky, 28; plan of the campaign and force of Gen. Buell, 28; from what States, 28; naval force to cooperate, 28; gunboats, 28; order of the President for an advance of all the forces, 29; effect, 29; movements after the battle of Mill Spring, 29; advance upon Fort Henry, 29; its capture by the gunboats, 31; advance of the gunboats up the Tennessee into Alabama, 31; preparations for an attack on Fort Donelson, 31; forces of Gen. Grant, 32; Confederate force, 32; remarks of Senator Trumbull, 32; location of the fort, 32; attack by the gunboats, 33; conflict with the land forces, 33; summons to surrender, 33; surrender, 33; troops captured, 33; effects, 35; Clarksville surrendered, 35; advance of Gen. Buell, 36; address of Gen. Mitchell, 36; evacuation of Nashville, 36; it surrenders, 37; effect upon the Southern people, 37; address of Gen. Halleck to the troops, 37; movement of gunboats to Columbus, 37; its occupation, 37; proceedings at Nashville, and important events elsewhere, 38.

Expedition of Gen. Burnside, 38; calls from Fortress Monroe, 38; the storm, 39; its disasters, 39; address of Gen. Burnside, 39; advance up Pamlico Sound, 39; capture of Roanoke Island, 40; thanks of the President, 40; expedition to Elizabeth City, 40; address of Gen. Burnside and Com. Goldsborough to the people of North Carolina, 41; proclamation of Gov. Clark, 41; advance upon Newbern, 42; defeat of the Confederate force, 42; congratulations of Gen. Burnside, 43; movement toward Beaufort, 44; expedition to Washington, N. C.,

44; capture of Fort Mason, 44; advance toward Norfolk under Gen. Reno, 44; skirmishes, 44; expedition to the Dismal Swamp Canal, 45; subsequent movements of Gen. Burnside, 45.

Expedition to South Carolina, 45; movements against batteries at Seabrook Island, 46; approaches to Savannah, 46; explorations at Wall's Cut, 46; further reconnaissances, 47; Wilmington Narrows, 47; attack on the vessels under Com. Tatnall, 47; preparations to capture Fort Pulaski, 48; attack, 48; surrender, 49; expedition against Fernandina, 49; its capture, 51; expedition to Brunswick, Ga., 51; St. Simon's Sound, 51; St. John's River, 51; Jacksonville, its surrender, 51; Union proceedings, 51; report of Com. Dupont, 51; Mosequito Inlet, 52; movements toward Charleston, 52; Wappoo Creek, 52; movement against Hilton Head, 53.

Movements in Missouri, 53; skirmishes at Mount Zion and Fayette, 53; occupation of Springfield by Gen. Curtis, 54; advance into Arkansas, 54; report of Gen. S. Price, 54; driven from Cross Hollows, 54; address of Gen. Curtis to the people, 54; position and strength of his forces, 55; advance of Confederate forces, 56; preparations for the battle at Pea Ridge, 56; the battle, 56, 57; flag of truce, 57; correspondence, 57; retreat of the Confederate forces, 58; movements of Gen. Curtis, 58; advance to Batesville, 58; lack of supplies, 58; ten regiments sent to Corinth, 58; moves to Helena, 58; expedition down the Mississippi, 58; expedition to White River under Gen. Hovey, 58; subsequent operations in Arkansas, 58; Cross Hollow, 60; Cane Hill, 60; Crawford's Prairie, 60.

Expedition down the Mississippi under Com. Foote, 60; land and naval forces, 60; reaches Columbus, 60; Island No. 10, 60; its situation, 60; fortifications, 61; movement of Gen. Pope, 61; capture of New Madrid, 61; occupies Point Pleasant, 61; takes his army across the Mississippi, 61; gunboat Carondelet runs past the batteries on the island, 62; evacuation of Island No. 10, 62; capture of Confederate force, 63.

New Confederate line of defence, 63; gunboats move down the Mississippi, 63; anchor at Plum Point, 64; naval battle with Confederate gunboats, 64; evacuation of Fort Pillow, 65; Gen. Pope ordered to Corinth, 65; naval battle before Memphis, 65; surrender of Memphis, 66; expedition up the White River, 66.

Operations in Tennessee, 67; forces of Gen. Grant, 67; line of defence, 67; Confederate force, 67; movements of the Federal force, 67; plan of Gen. Buell, 68; Pittsburg Landing, 68; battle at Shiloh, 69, 70, 71, 72, 73; despatch of Gen. Beauregard, 73; message of President Davis to the Confederate Congress, 73; Gen. Halleck takes command and moves on Corinth, 74; its situation, 75; advances of the Federal army, 75; despatches of Gen. Halleck, 75; evacuation of Corinth, 76; Confederate works, 76; pursuit of the Confederate forces, 78; movements of Gen. Mitchell, 78; capture of Huntsville, 78; seizure of the railroad, 79; operations in Alabama, 79; close of operations in Tennessee, 80.

Situation in Virginia, 80; movements of Gen. Lander, 80; intended movements of Gen. Jackson, 80; attack at Blue's Gap, 81; march of Gen. Lander from Romney, 81; position of the Confederate army; 81; address of Gen. Beauregard, 81; do. of Gen. Johnson, 82; design of Gen. McClellan, 82; effects of the order of the President for a general movement of all the troops, 82; a decided injury, 83; opinion at Richmond on this order, 83; salvation of the Confederacy, 82; Federal movement at Harper's Ferry, 82; retreat of Confederate army commenced, 83; battle of Winchester, 83; new Confederate line, 83; order of the President dividing the army of the

Potomac into corps, 84; assigning Gen. McClellan to the command, 84; effect, 84; address of Gen. McClellan, 84; exposure of his plans, 85; his position, 85; movement of troops begun, 86; number in the army of the Potomac, 86; withdrawal of Gen. Blenker's division, 86; reason, 86; Letter of President Lincoln, 86; withdrawal of Gen. McDowell's corps, 87; statements in the Senate, 87; statement of Gen. McClellan at a court martial, 88; his instructions to Gen. Wadsworth, 88; do. to Gen. Banks, 88-89; letter to Gen. Thomas, 89; further statements of Gen. McClellan in a court martial, 90; generals under command of Gen. McClellan, 90; countermanded, 90; order creating the Mountain Department, 90; do. Shenandoah, 90; do. Rappahannock, 90; duty assigned to Gen. McDowell to protect the capital, 90; movements of the army of the Potomac from Fortress Monroe, 90; Yorktown, 90; Gloucester, 90; progress of army, 92; attack of Vermont troops on the enemy's line, 93; sharpshooters, 93; operations of the siege, 93; evacuation of Yorktown, 94; causes to retard its capture, 94; guns captured, 94; situation of Williamsburg, 94; advance upon, 94; movements of Gen. McClellan, 94; misinformed of affairs in front, 94; fight before Williamsburg, 95; success of Gen. Hancock, 95; arrival of Gen. McClellan, 96; address to the troops, 96; advance of Gen. Franklin to West Point, 96; conflict, 96; aid of the gunboats, 96; delays at Williamsburg, 97; evacuation of Norfolk, 97; its occupation by Federal troops, 97; advance of Gen. McClellan's army, 98; description of the country, 98; concentration of Confederate forces, 99; skirmishing, 99; instructions from the War Department, 99; to Gen. McDowell to join Gen. McClellan, 99; movement under Gen. Porter upon Hanover Court House, 99; conflict, 100; opinion of Gen. McClellan on the effect of a junction with Gen. McDowell, 100; Prince de Joinville, 100; cause of the failure of Gen. McDowell to join Gen. McClellan, 100; advance of the former to Fredericksburg, 101; Gen. Shields sent to join Gen. McDowell, 101; orders from the War Department to Gen. McDowell how to proceed after the junction with Gen. Shields, 101; force of Gen. Shields, 101; joins Gen. McDowell, 101; ordered to fall back to relieve Gen. Banks, 100; correspondence, 101; Gen. Shields falls back, 102; Gen. Fremont's department, 102; his movements, 102; conflict at McDowell, 104; Gen. Fremont ordered to the relief of Gen. Banks, 104; order of the President, 104; his reply, 104; reaches Strasburg, 105; skirmish with Gen. Jackson's rear, 105; valley of the Shenandoah, 105; situation of Gen. Banks, 105; connection with the forces east, 105; the plan to capture Gen. Banks, 105; designs of the enemy, 105; movements of Gen. Jackson, 105-106; attack at Front Royal, 106; plan of Gen. Banks on hearing of it, 106; his movements, 106; retreats, 106; pursuit of Gen. Jackson, 106; fight at Winchester, 106; further retreat, 107; crossing of the Potomac, 107; address of Gen. Jackson to his troops, 107; panic occasioned by the attack at Front Royal, 107; extends to Washington, 107; alarm of the Government, 107; telegraphic despatch of the Secretary of War, 107; do. of Gov. Morgan of New York, 107; orders of Gov. Curtin of Pennsylvania, 107; proclamation of Gov. Andrew of Massachusetts, 108; order of Gov. Sprague of Rhode Island, 108; proclamation of the Governor of Ohio, 108; order of the Secretary of War taking military possession of the railroads, 108; excitement in the Northern States, 108; success of Gen. Jackson's movements, 108; advance upon Harper's Ferry, 109; attack by his rear guard, 109; retreat of Gen. Jackson, 109; of his rear, 109; position of Gen. Fremont and Shields, 109; Gen. Fremont attacks Gen. Jackson's rear guard, 110; movements of Gen. Shields, 110;

movements of Gens. Banks and Sigel, 110; Gen. Fremont attacks the rear of Gen. Jackson beyond Strasburg, 110; pursuit continued, 110; affair near Mt. Jackson, 111; conflict near Harrisonburg, 111; Col. Ashby killed, 111; battle at Cross Keys, 111; situation of Port Republic, 111; advance of Gen. Shields repulsed, 112; Gen. Jackson escapes, 112; Gen. Fremont reaches Port Republic, 112; force of Gen. Jackson, 113; advance of Gen. Heath in Western Virginia and defeat, 118; consequences of these movements to prevent reinforcements to Gen. McClellan, 118; order of Gen. McClellan to his troops, 118; crossing of the Chickahominy, 118; battle of Fair Oaks, 114, 115, 116; retreat of the Confederate troops, 116; difficulties in capturing the city, 116; Confederate march in the rear of Gen. McClellan, 117; another prospect of the cooperation of Gen. McDowell, 117; letters of Gen. McDowell, 118; address of President Davis to the Confederate army, 118; completion of the bridges across the Chickahominy, 118; advance of Gen. Hooker, 118; his recall, 118; reason, 118; plans of the Confederate generals, 118; flank march of Gen. Jackson, 119; position of Gen. McClellan's forces, 119; attack on his right, 119; firm resistance of Gen. Porter's corps, 121; crossing to the right bank of the Chickahominy, 121; opinion of Confederate officers, 121; further developments, 121; plans of the Federal general comprehended, 121; battle at Savage's Station, 122; do. at White Oak Swamp, 122; do. at Charles City Crossroads, 122; confusion of the Confederate troops, 123; "Onward to Richmond" shout of Federal troops, 123; desperate valor of Confederate troops, 123; attack of Gens. Wise and Holmes, 123; attack at Malvern Hill, 123; army at Harrison's Landing, 123; address of Gen. McClellan to his soldiers, 123; address of President Davis to Confederate army, 124; arrival of Gen. Halleck, 124; his views, 124; instructions to Gen. McClellan, 124; letter of Gen. McClellan, 124; reply of Gen. Halleck, 125; army of the Potomac withdrawn from the Peninsula, 124.

Gen. Pope assigned to command the army of Virginia, 126; Gen. Fremont resigns, 126; Gen. Pope's address, 126; his orders, 127; situation of his army, 127; plans of the Confederate officers, 128; call of the President for three hundred thousand men, 128; movement of Confederate troops, 128; skirmishing on the Rappahannock, 128; battle of Cedar Mountain, 130; capture of Louisa Court House, 130; nature of the country, 131; forces of Gen. Pope begin to fall back, 131; Rappahannock bridge, 131; attempts of Confederates to cross the Rappahannock, 131; dash on Catlett's Station, 132; advance of Confederate army, 132; Gen. Pope continues to fall back, 132; concentration of his forces, 133; attack at Manassas Junction, 133; attack on Bristow's Station, 133; further movements of the Confederate forces, 133; continued retreat of Gen. Pope, 133; battle near Manassas, 134; conflict near Gainesville, 134; battles near Bull Run, 135; despatch of Gen. Lee, 135; message of President Davis, 135; excitement at Washington and through the North, 136; Gen. Pope falls back to the heights of Germantown, 136; his correspondence with Gen. Lee, 136; retreat of Gen. Banks, 136; battle of Chantilly, 137; retreat of Gen. Pope's army to fortifications at Washington, 137.

Movements of the Confederate forces, 137; advance toward Maryland, 137; enter Frederick, 138; address of Gen. Lee to the citizens of Maryland, 138; evacuates Frederick and enters Hagerstown, 138; excitement in Pennsylvania, 138; activity in Maryland, 139; Gen. McClellan ordered to command the troops for the defence of Washington, 139; effect upon the troops, 139; advance sent forward into Maryland, 139; movements

of Gen. Lee, 139; his order to Gen. Hill showing his plans, 140; advance of Gen. McClellan's forces, 140; enter Frederick, 140; pursue Confederate forces, 140; battle of South Mountain, 140, 141; movements at Harper's Ferry, 141; its surrender, 142; spoils taken, 142; battle at Antietam, 143, 144; losses, 144; retreat of the Confederate army from Maryland, 144.

Guerilla operations in Kentucky, 144; advance of Gen. E. K. Smith into Kentucky, 144; battle at Richmond, 144; removal of the Kentucky Legislature, 144; address of the governor, 145; proclamation of Gen. Smith, 145; movements of Gen. Buell, 145; advance of Gen. Bragg into Kentucky, 146; capture of Munfordsville, 146; object of Gen. Bragg's advance into Kentucky, 147; his address to the Kentuckians, 147; advance of Gen. Buell in pursuit, 149; battle of Perrysville, 149; Camp Dick Robinson, 149; spoils taken by Gen. Bragg, 150; his retreat and the pursuit, 150; result of the invasion of Kentucky, 151.

Cumberland Gap, its situation, 151; occupation by Confederate forces, 151; invasion by a Federal force, 151; its evacuation, 151; occupation by Gen. Morgan, 152; skirmishes, 152; evacuation by Gen. Morgan, 152.

Movements of Gen. Grant's forces in Tennessee and Mississippi, 152; dash upon Iuka, 153; movements of Federal forces upon Iuka, 153; its capture, 153; march of the Confederate forces upon Corinth, 154; position of the forces, 154; battle of Corinth, 155; retreat of the Confederate force, 156; pursuit, 156; address of Gen. Rosecrans, 156; advance of Gen. Grant's forces, 156; movement by a division of Gen. Curtis' army, 156; expedition from Helena, 157; capture of Holly Springs, 157; close of the second campaign in Kentucky and Tennessee, 158.

Gen. Rosecrans ordered to the command in Kentucky, 158; advance toward Nashville, 158; position of the Confederate forces, 158; Federal advance beyond Nashville, 159; position of the armies at Murfreesboro', 159; the battle at Murfreesboro', 159, 160, 161; losses, 161.

Conclusion of the campaign in Virginia, 161; position of the armies, 161; order to Gen. McClellan to cross the Potomac, 163; letter of Gen. Halleck to the Secretary of War, 163; causes of delay to advance, 163; advance of the troops, 163; the situation of the respective forces, 164; removal of Gen. McClellan, 164; his farewell to the troops, 164; the military aspect of affairs, 164; movement upon Fredericksburg, 165; that city summoned to surrender by Gen. Sumner, 165; correspondence, 166; concentration of Federal army, 166; delay of pontoons, 166; testimony of Gen. Burnside, 167; battle in the rear of Fredericksburg, 168, 169; retreat of the Federal forces, 170; despatches of Gen. Burnside, 170; address of Gen. Lee to his troops, 170; dash upon the Cumberland Gap, 171; attack upon Goldsboro', 171; fight at Pocotaglo, 172; at Baton Rouge, 172; summary of important military events, 172; results of the military operations of the year, 173.

*Astronomical Phenomena and Progress.* Asteroids, 173; comets, 174; new theory of, 174; nebulae, 175; stars, 176; refraction, 176.

*Auroras*, early observations of, 177; theories, 177; experimental observations on electric discharge, 178; other theories, 178; magnetic currents, 179; apparatus of M. De la Rive, 179; observations, 180.

*Austria*, emperor, 180; proceedings of Parliament, 181; parties, 181; efforts of the Government to overcome discontent, 181; nationalities of Austria, 182; population of cities, 182; financial condition of the empire, 182; expenditures, 182; receipts, 183; standing army, 183; navy, 183; religious statistics of the empire, 183.



- Ballooning**, practical applications of the art, 184; reconnaissance in war, 184; telegraphic connection, 184; reconnaissances before Washington and on the Peninsula, 185; ascent to great heights, 185; Mr. Gashier's ascent, 185; results, 185, 186, 187.
- BANKS, GEN. N. P.**, commands at Cedar Mountain, 180; takes command at New Orleans, 652.
- Baptists**, different denominations in the United States, 187; numbers, 187; anniversaries, 188; charitable contributions, 188; Baptists in England, 188; Pastor's College, 188; 50th annual session in London, 188; Baptists on the Continent, 189; Germany, 189; France, 189; Denmark, 189; missionary churches in India, 189; other missionary churches, 189.
- Barometer**, its uses, 189; measure heights by inspection, 190; observation on, 190; vertical movements of the atmosphere, 190; method for recording temperatures and pressures in balloon ascents, 191.
- Batesville**, its situation, 191; population, 191.
- Baton Rouge**, its situation, 191; battle at, 191.
- Beaufort**, its situation, 191; population, 191; capture, 191.
- BEAUBEGARD, GEN.**, address to his soldiers in Mississippi on taking command, 67; dispatch at the battle of Shiloh, 78; address, 74; address to his troops in Virginia, 81.
- BECKWITH, JOHN CHARLES**, birth, 191; death, 191; education, 191; public services in the army, 191; efforts to improve the condition of the Waldensians, 191.
- BEREFORD, JOHN GEORGE**, birth, 192; education, 192; services, 192; death, 192.
- BETHUNE, GEORGE W.**, birth, 192; education, 192; death, 192; writings, 192.
- Blockade**, its effectiveness, 196; letter of J. M. Mason to Earl Russell, 198; reports of British naval officers, 198; letter of Earl Russell to Lord Lyons, 198; views advanced in the House of Commons, 194; speech of the Solicitor-General, 194; speech of Lord Stratheden, 194; reply of Earl Russell on the effectiveness of the blockade, 195, 196; deliberate opinion of the British Government, 196; remarks of M. Regnault in the French Legislature, 196; reply of M. Billault, 196; memorial of British shipowners to the Secretary on Foreign Affairs, 197; reply of Earl Russell, 197.
- BOOCOCK, THOMAS S.**, speaker of the Confederate House, 257; his address, 257.
- Border States**.—Appeal of President Lincoln to, on emancipation, 721; replies of members of Congress, 723, 723, 724, 725.
- Brazil**, its situation, 197; provinces and population, 197; difficulty with Great Britain, 197; facts of the case, 197; another cause of complaint, 198; correspondence between the Governments of the two countries, 198; propositions for adjustment, 199; accepted under protest, 199; difficulty on the Amazon, 199; progress of the country, 199; commerce, 200.
- BRODIE, BENJAMIN C.**, birth, 200; death, 200; education, 200; distinction as a surgeon, 200.
- BROWN, JOSEPH E.**, Governor of Georgia, opposes conscription, 244; correspondence, 244.
- BUCKLE, HENRY T.**, birth, 200; education, 200; pursuits, 200; writings, 201; death, 201.
- BUELL, GEN. DON CARLOS**, his force in Kentucky, 28.
- Building Materials**.—Tendency to decay, 201; investigation in England, 201; Westminster Palace examined, 201; extent and position of decay, 201; causes, 201; best means of prevention, 202; qualities of stone recommended for future use, 203; principles likely to be effective in accomplishing the preservation of stone, 203; various applications, 203; processes, 204; mode of decay over-
- looked, 205; preservation of timber, 205; processes used, 205.
- BURNIDE, GEN. AMBROSE E.**, commands expedition to North Carolina, 88; address to his troops, 89; address to the people of North Carolina, 41; advance upon Newbern, 42; congratulates his troops upon their success, 42; appointed to command the army of the Potomac, 164; his orders, 165; his testimony before a committee of Congress, 167; orders before Fredericksburg, 170.
- BUTLER, GEN. BENJAMIN D.**, proceedings at New Orleans, 645; retires, 652.

## C

**California**, its situation, 206; civil officers, 206; amendments to the State Constitution, 206; State debt, 206; revenue, 207; civil affairs, 207; floods in the State, 207; mines and mining, 207; agricultural products, 208; gold and silver exported, 208; population, 208.

**CAMMERON, SIMON**, resigns as Secretary of War, 82; arrested on process of a court, 511.

**CANNING, CHARLES JOHN**, birth, 206; education, 206; public services, 206; death, 206.

**Chemistry**.—Elements, 208; cesium, 208; rubidium, 208; thallium, 209; lithium, 209; compounds—hydruret of iron, 209; silicuret of hydrogen, 210; peroxide of potassium and sodium, 210; hydrofluosilicic acid, 210; hydrochloric acid, 210; combustion of hydrocarbons in air at ordinary temperature, 210; allotropic states—oxygen, 211; nitric acid, 212; syntheses of organic substances, 213; alcohol, 213; dialysis, 214; transpiration, 215; applications of chemistry, 216; Webster's oxygen process, 216; potash for the animal kingdom, 216; copper paint, 216; aluminium bronze for philosophical instruments, 216; artificial plumbago, 217; determination of carbon in iron, 217; nitrogen in iron, 218; new fusible alloy, 218; cupreous acetylene, 218; improved matches, 218; India rubber varnish, 218; basis of artificial teeth, 218; guano polishing powder, 219; cement for rooms, 219; new system of bottling liquids, 219; new process of making vinegar, 219; new hydrometer 220; myrtle wax, 220; aniline colors, 220; Parkesine, 220; Australian oils and resins, 221; organic alkaloids, 221; refining sugar, 221; detection of picrotoxin, 221; oxygenated beverages, 221; preservation of meats, 222; rendering fabrics non-inflammable, 222; awards of the Exhibition of 1862, 222.

**Chili**, its situation, 222; provinces and population, 222; its claims to territory, 223; Aracanians, 223; tranquillity of the country, 223.

**Cochin China**, its boundaries, 223; population, 223; character of the country, 223; products, 223; difficulties with France, 224; military expeditions, 224; treaties, 224.

**COLT, SAMUEL**, birth, 225; death, 225; education, 225; pursuits, 225; inventions, 225; enterprise, 226; successes, 226; nature of his inventions, 226.

**Commerce of the United States**.—Demands for cotton, 227; movements in Kentucky and Tennessee, 227; operations at New Orleans, 227; comparison with other years, 228-229; opening the ports of North and South Carolina, 229; limits of the trade of the country, 229; exports from New York, 230-231; St. Mary's Canal, 230; influence of the operations of the banks, 231; rise in values, 231; imports of New York, 232; imports of cotton into Great Britain, 232; interruption to trade, 233; revenue at New York, 233; transfer of vessels to the English flag, 233; increase of foreign tonnage, 234; ocean steamers, 234; coastwise trade, 234.

**Confederate States**.—Population and resources under the census of 1860, 235; political proceedings from February,

1861, to January, 1862, 236; the Government weak and trembling for its existence in January, 1862, 237; influence of the Union policy of the Federal Government, 237; necessity of war to the Confederate States, 237; effects of it partially counteracted by moderate policy of Federal Government, 238; other causes to make the Confederate States weak, 238; disappointments in Europe, 238; success of the blockade, 238; call upon the people for arms, 238; attempts to rouse the people, 239; action of the State Legislatures, 239; of Confederate Congress, 239; Union sympathy at Richmond, 239; do. in Tennessee, 240; address of the Georgia members of Congress, 240; military plans, 241; inauguration of the permanent Government, 241; appeals to the people, 241; Confederate army, its condition, 242; conscription recommended to Congress, 242; furloughs revoked, 243; effect of the Federal military movements upon the Government and people, 243; the conscription act, 243; how executed, 243; its constitutionality questioned, 243; opposition at the South, 244; correspondence with the Governor of Georgia, 244; opinion of the Supreme Court of Georgia, 245; opposition in Alabama, 245; manner of executing the law, 245-246; rewards for the apprehension of deserters, 246; partisan rangers authorized, 247; the act, 247; instructions of the Secretary of War, 247; second conscription act, 247; its peculiar features, 247; calls for shot guns, sulphur, lead, and saltpetre, 248; order relative to bells of churches, 248; contributions of churches and individuals, 248; other sources for the supply of arms and munitions of war, 249; plans of defensive operations adopted by the Government, 249; preparations of the Confederate Government, 249; alarm at the approach of McClellan's army, 249; contraction of the line of defence, 250; object of the invasion of Maryland, 250; do. of Kentucky, 250; civil organization of the Confederate Government, 250; its finances, 250; loans, &c., 251; bonds and debt, 251-252; taxes, 253; plans to burn cotton, 253; manufactures, 254; postage system, 254; martial law, 254; foreign relations, 254; position at the close of 1862, 255; gradual exhaustion, 255; speech of Vice President Stephens, 255.

*Congregationalists.*—Numbers, 255; location, 255; enterprise, 255; numbers in England, 256; do. in British colonies, 256; missionaries, 256; similar churches in France, Italy, Switzerland, 256.

*Congress, Confederate,* its meeting and organization under the permanent constitution, 256; members, 256-257; address of the Speaker of the House, 257; votes cast for the President, 258; resolution offered in the House to abandon the defensive policy in the conduct of the war, 258; objected to as impeaching the Administration, 258; no people in a revolution ever adopted a defensive policy, 258; the generals have had the most liberal discretion, and the President not responsible, 259; Hannibal and the philosopher, 259; no disrespect intended, 259; more of an aggressive policy should have been adopted, 259; resolution laid on the table, 259; bill passed directing military commanders to destroy cotton, &c., 259; joint resolution relative to the war with the United States, 260; compensation of members, 260; resolution adopted to entertain no peace propositions excluding any portion of the soil of any Confederate State, 260; suspension of Gens. Floyd and Pillow, 260; a bill to curtail the cotton crop considered, 260; unconstitutional, 260; Congress cannot create a crime, 261; allowing cotton to fall into the hands of the enemy was giving him comfort, 261; cultivation of cotton should not be abandoned, 261; Congress no power to interfere with the internal affairs of the States, 261; the idea that cotton is king long since abandoned, 261; England will never interfere,

261; bill lost, 262; report on the surrender of Roanoke Island, 262; moneys transferred to the Confederate States Government by the several States, 263; appropriations for the Navy Department, 263; resolutions relative to the battle of Shiloh, 262; Treasury notes less than \$5 authorized, 263; increase of clerks in the departments, 263; adjournment to August 18th, second session convened, 263; bills introduced, 263; remarks on the conscription act, 263; resolution to transact business with open doors rejected, 264; resolutions favoring an aggressive war, 264; also favoring a proclamation to the people of the Northwestern States, 264; vote of thanks to the commander at Drury's Bluff, 264; message from President Davis with despatches from Gen. Lee, 264; vote of thanks to Gen. Lee on crossing the Potomac, 265; amendment proposed, 265; Congress not prepared to invite the Government to invade the enemy's country, 265; after we have crossed the border we are told we ought to hesitate, 265; could not take the responsibility of advising an advance into Pennsylvania, 265; what the people wanted was an aggressive war, 265; could the army safely go into the heart of the North? 265; it is not a war of conquest, but of independence, 265; amendment lost, 265; further debate on the resolutions, 266; passed, 266; an additional resolution proposed as not intended to indicate a policy for the President, 266; reports of the committee on the opening of Southern markets to the Northwestern States, 267; majority report in favor, minority opposed, 267; bill to provide further for the public defence passed, 267; motion to reconsider, 267; remarks on the difficulties between the Government and the States relative to conscription, 268; retaliatory measures considered, 268; report of a committee with a bill, 269; minority report, 269; remarks on President Lincoln's proclamation, 269; another bill proposed, 269; whole matter disposed of, by a resolution to sustain the President, 270; sequestration bill considered, 270; is the bill constitutional? 270; this is no civil war, but a war of some sovereign States against others, 270; no such thing as a citizen of the Confederate States, 270; people a right to choose their own government, 270; you cannot hang a man as a traitor to a government that has been made without his consent, 270; further debate, 271, 272, 273; bill laid on the table, 273; appropriations, 274; issue of copper coin authorized, 274.

*Congress of the United States, second session of Thirty-seventh, convened,* 275; members, 275; views of the majority, 275; vote of thanks to Commander Wilkes passed in the House, 276; anti-slavery resolutions offered, 276; resolutions proposing a conference with the Southern States offered, 276; further resolutions relating to slavery, 277; confiscation bill introduced, 277; its features, 277; grants of power in the Constitution, 278; armies in the field, 278; necessity for some regulation to govern the commanders, 278; other reasons for the measure, 278; further resolutions offered, 279.

Resolution relative to the order of Gen. Halleck, 279; considered, 279; system of excluding slaves inaugurated in Western Virginia, 279; a disgrace to the profession of arms, 279; no authority from the President to issue these orders, 280; explanation of Gen. Halleck, 280; this order regarded most wise and salutary by the officers and soldiers, 280; policy of the administration to deliver up the slaves to their masters, 280; the contrary inferred from the President's message, 281; the administration has had no hand directly or indirectly in the order of Gen. Halleck, 281; letter from Gen. Halleck, 281.

Resolutions relative to the conduct of the war con-

sidered, 281; let the military arm strike that blow more effective for peace and freedom than armies or victories can be, 281; whether right or wrong the majority of the soldiers are opposed to this anti-slavery agitation, 281; worst kind of folly and wickedness to retain slavery, 281; does not the President stand pledged before the country and the world to the conservative policy? 283; further debate, 283; resolution referred, 283.

Resolution of inquiry relative to arrests, 283; what arrests is it proposed to consider, 284; the right thing done at the right time, 284; the Constitution confers all the power that is necessary to enable the Government to crush secession, 284; it is assumed that these persons are traitors, but who is to decide that? 284; what becomes of constitutional liberty? 284; let this thing be regulated by law, 285; the resolution carries an implied censure upon the Government, 285; the resolution eminently proper, 285; some investigation of these arrests should be made, 286; are we fighting for the Constitution? 286; when these arrests were made the loyal people of the country felt that they had a Government, 286; if this is not the proper mode to make arrests, then bring in a bill to regulate it, 286; who seeks to make it a censure on the administration? 286; no necessity to trample on the Constitution in order to maintain it, 287; the man who stops to inquire whether there is a law, when the house is burning, is unfit for a great place, 287; inappropriate time to adopt the resolution, 287; referred to the Judiciary Committee, 288.

Bill to raise a volunteer force in Kentucky considered, 288; more soldiers now than can be used, 288; reasons for the bill, 288; economy forbids it, 288; what does the bill propose? 289; if you change the object of the war you paralyze the army, 289; not a war for the emancipation of slaves, 289; what evidence that more soldiers are needed, 290; importance of the bill, 290; peculiar situation of Kentucky, 290; force of Kentucky in the field, 290; best reason in the world for believing there are not men enough, 291; those who refuse to vote troops, derelict, 291.

Resolution that none but persons of superior competency should be appointed generals considered, 291; not half the brigadiers needed, 292; enough general officers now, 292; the question of expense should be considered, 292; thousands of volunteers unfit for duty, 293.

Resolution relative to using the soldiers to surrender fugitives considered, 293.

Inquiry relative to passports for California considered, 294, letter of Secretary Seward, 294.

Resolution relative to the cause of the war considered, 295; no just cause of war at the South, 295; what was the primary inciting cause? 295; dissatisfaction with the principles and operation of democratic government, 295; white laborers at the South, 295; views of Southern men, 296, 297.

Resolution calling for a copy of the proclamation of Gen. Phelps considered, 298; desirable to know authoritatively and positively that it is not an act of the Government, 298; an offset to the proclamation of Sherman and orders of Halleck, 298; resolutions offered in the House, 299.

Resolution relative to disloyalty of persons in the employ of the Government considered, 299; correspondence with the secretaries, 299; their replies, 299.

Resolution to inquire into the loyalty of the Senator from Oregon before administering the oath, 300; understood to be an open and avowed supporter of secession,

300; no precedent for such a motion, 300; the times are those when we are compelled to make precedents, 301; it belongs to the Senate to make a precedent, 301; this is not a new state of things, 301; right and duty of the Senate to make the investigation, 301; what are the facts? 301; he has a right to be sworn in, 302; is not loyalty a qualification under the Constitution, 302; the case of Philip Barton Key in 1808, 302; the question of loyalty too indeterminate and rests upon opinion, 302; different views of loyalty, 302; would you admit a felon? 302; with credentials—yes, 302; credentials referred, 303.

Inquiry relative to Ball's Bluff, 303; object of the resolution, 304; the question is—will the House interfere in the conduct of the war? 304; the Constitution provides that the military shall be subject to the civil power, 304; the nation has failed rightly to interpret the providences of God, 305; when we cast this accursed slavery overboard God will give us success, 305; if the institution of slavery ever stands in the way of constitutional liberty the people of Kentucky will wipe it out, 306; further debate, 307.

Resolution for a tax considered, 307; for twenty-six years the question of slavery has been debated in this House, 308; prepare for the great question of finance, 308; the war power of the Government under no limitation, 308; the essential destruction of lives and property justifiable, right, and proper, 308; Government invested with the right of self-defence and self-preservation, 308; such the rights, what are the duties of the Government. 309; the most needed of all was an act to liberate the slaves, 309; have the constitutional power, 309; no boundaries to the power of Congress? 309; not one dollar, nor one man to be voted under such an interpretation of the Constitution, 310; Congress can provide for the common defence only in the manner that the Constitution points out, 310; if we are successful without an interference with slavery, we return from victory like the Thracian horse, bearing his master on his back, 311; if abolitionism rules, this will be a war of extermination and death all over the country, 311; the first summons from the Government read, 312; what did the President mean by alleging there should be no interference with property of any kind, 312; to judge from the debates it would appear that the President had no support from the party that elected him, 312; universal emancipation must be proclaimed to all, 313; when the Constitution is defied and set aside, it grants to the President and Congress a supplemental power increasing and varying according to the increasing and varying necessities of the nation, 313; if no other means were left to save the Government we have power under the Constitution and according to its express provision to declare a dictator, 313; the war power is our special property, 314; how it should be used, 314; declare the oppressed to go free, 314.

Better attend to providing the means and the men for putting down these enemies, 314; the conduct of a war is specially confined to the executive department, 315; what are the motives and ends of the Committee on the War, 315; the commander-in-chief has been before the committee, 315; they intend to usurp the prerogatives of the executive, 316; the largest latitude is given to the President, Secretaries of War and Navy in the conduct of the war, 316; is it intended to force the administration into a John Brown raid, 317.

Issue of treasury notes considered, 317; necessary to carry on the war, 317; legal tender, 317; a novel proposition, 318; impair the obligations of every contract, 319; Congress has not power to do it, 318; the financial plan of the Government, 318; not one sound precedent for a

paper currency, 818; Congress has the power to declare what shall be a legal tender, 819; point out the words in the Constitution, 819; Congress has not the power to debase coin, 820; three propositions the sum of the argument, 821; existence of the Government depends upon its successful finance, 821; we are to conform our action to the Constitution of the country as it is, 822; what is this legal tender? 822; what power in the Constitution, 822; to coin money, 823; regulate commerce, 822; imperative necessity brings out the latent powers of the Constitution, 823; is this measure necessary to suppress the enemy, 823; bill passed the House, 824; vote, 824; in the Senate the bill considered, 824; legal tender constitutional, 824; obligation of an oath to support the constitution, 824; proposed to make these notes a legal tender to pay private debts, 824; who compelled to take this money, 825; said to be incidental to a great variety of powers, 825; those who choose may exercise their own judgments on the constitutionality of the measure, 826; a palpable violation of the Constitution, 826; Constitution silent, 826; if the Constitution has failed to speak Congress has not, 826; bill passed, 827.

Bill to authorize the President to take possession of railroads and telegraph lines, 827; its object, 827; where the judiciary cease the military begin to operate, 828; an extraordinary bill, 828; where do you get authority to subject civil employés to the articles of war, 828; an unauthorized power, 828; what is the whole object of the bill? 828; the power to do these things exists, 828; the war power is vested in Congress, not in the President, 828; without our assent the President cannot exercise what powers he pleases in the conduct of the war, 829; extending martial law over railroads, 829; the first step which costs, 829; the doctrine of state necessity at all times dangerous, 830; bill passed, 830.

Resolutions for the expulsion of the Senators from Missouri, 830; report on, 831.

Resolution for the expulsion of Senator Bright of Indiana, 831; debate, 831, 832; passed, 832.

Bill to prohibit slavery in the Territories considered, 832; amendment offered, 833; effects of emancipation in the British West Indies, 833; what involved in the negro question, 834; this bill a part of a series of measures already initiated, 834; Congress has no power to emancipate a slave anywhere, 835; all the rights secured by the Constitution to the citizen exist in the District of Columbia as elsewhere, 835; on what terms can private property be taken, 835; statements of the Administration on the objects of the war, 835; have not the American people the right to relieve themselves from the guilt of upholding slavery, 836; protest in the name of Maryland, 836; views of Henry Clay, 836; cannot place expediency in the scale against justice, 837; has slavery a national existence at the capital? 837; shall money be paid for its abolition? 837; examination of the constitutional question, 838; it is denied that property can exist in a human being, 838; slavery exists by the law of nations, 839; the slave trade cannot be restricted except by positive legislation, 840; slave trade would have been a legitimate trade to the citizens if the Government had not declared it piracy, 840; opinions of the Supreme Court, 840, 841; the Constitution treats the slaves as persons as well as property, 842; property in a horse has its origin in force, 842; vote on the question, 843; inexpediency of the measure, 843; is not this the commencement of a great system? 844; vote on the bill in the House, 844; message of the President on the bill, 845.

Resolutions declaring the relations between the United States and the territory once occupied by certain States, 845; other resolutions on the same subject, 846.

Resolution relative to emancipation with compensation, 846; where is the power in the Constitution to appropriate money for this purpose? 846; too late to discuss that question, 847; an olive branch of peace, harmony, and good faith, 847; simply a declaration of opinion, 847; amendment offered, 848; the proposition of the President promises nothing, 848; is this power granted? 849; vote on the resolution, 849.

Bill relative to confiscation considered, 849; intended to operate on property, 849; competent for Congress to prescribe punishment, 849; further provisions and objects of the bill, 850; the right of confiscation relative to slaves, 851; further provisions of the bill, 851; what constitutional power to transport, colonize, and settle emancipated negroes, 851; what is to become of the Union men of the South with millions of freed slaves left to roam at large, 851; this measure can never secure peace, 852; shall we stand or fall by the Constitution or leave it and adventure on the wide sea of revolution? 852; this bill would liberate three million slaves at a blow, 852; effect upon the war, 853; pass this bill and all that is left of the Constitution is not worth much, 853; the supreme power of conducting war is in Congress, 853; no limit to the power of Congress, 856; it leaves to the citizens of the seceded States the ownership of nothing, 854; want of power, 854; Congress cannot interfere with slavery in the States, 855; wars should not be a revengeful policy, 855; ends for which the Constitution was made, 856; two classes of persons whose property is forfeited, 856; it will cut off the great market of the free States, 856; depriving a person of his property without process of law, 857; Congress no right to interfere with slavery in a State, 857; interfering with pledged faith, 858; subject referred to a select committee, 858; report, 858; the bill reported unconstitutional, 858; moved to except slaves, 858; liberation is not confiscation, 858; the term forfeiture, 859; a substitute, 859; votes on the amendments, 860; motion to strike out the section authorizing the President to issue a proclamation of emancipation, 860; Congress no power to authorize him, 860; inexpedient, 861; contest in the Senate on the bill, 862; the debate in the House, 862; the Constitution not to be trampled on, 862; the bills examined under the law of nations and the Constitution, 862, 863, 864, 865; contest in the Senate renewed, 866; not one single word or letter in the Constitution which gives Congress any power to do an act in the exigency of war, which it cannot do in times of peace, 866; the doctrine that would concentrate all power in the Executive most fatal, 867; indifferent whether the Federal or Confederate States triumph, 867; the war power of the Government explained, 867, 868; doctrines subversive of every principle of free government, 869; authority of the President over the army and navy, 869; has Congress authority to control or direct the President in the use of the military force, 869; fatal sophistry to deny it, 869; manner in which the proceedings of the Senate have been conducted, 870; vote on the bill, 870; a substitute moved, 871; vote, 871; committee of conference, 871; subsequent legislation on the measure, 871; amendments moved, 872; confiscation and forfeiture, 873; features of the bill, 873; explanatory provision, 874; adopted, 874; message of the President relative to the bill, 874.

Acts of a general nature passed, 875; number of representatives in Congress, 875; additional article of war, 875; abolition of slavery in the District of Columbia, 875; department of agriculture, 875; homesteads to settlers, 875; railroad and telegraph to the Pacific, 875; punishment of polygamy, 875; oath to be taken by public officers, 876.

*Connecticut*.—Its situation, 376; civil officers, 376; census returns, 376; institutions, 376; census statistics, 377; proceedings of the Legislature, 377; debt of the State, 377; troops furnished, 377.

*Conscription in Confederate States*.—Act recommended by President Davis, 243; its adoption, 243; features, 243; constitutionality, 243; opposition at the South, 243; correspondence of the Governor of Georgia, 244; opinion of the Supreme Court of Georgia, 245; opposition in Alabama, 245; desertions, 246; debate in Congress, 263.

**CRITTENDEN, Gen. GEORGE B.**—Address to the people of Kentucky, 37.

**CURTIS, Gen.**—Address to the people of the southwest, 54; correspondence with Gen. Van Dorn, 57; appointed to command the department of Missouri, 58.

### D

**DAVIS, President JEFFERSON.**—Message on the capture of Fort Donelson, 85; message to Confederate Congress, 73; address to the army after the battle of Fair Oaks, 118; after seven days' battles, 184; message to Confederate Congress on despatch of Gen. Lee, 185; his inauguration at Richmond, 341; his views, 241; recommends a conscription law, 243; on its constitutionality, 243; letter to Gen. Lee respecting retaliatory measures, 715; his Inaugural address, 732; message at the first session of the permanent Congress, 734; do. at the second session of the permanent Congress, 735; retaliatory proclamation, 736.

*Decatur*.—Its situation, 378; military movements at, 378.

*Delaware*.—Its situation, 373; State election, 373; census statistics, 373; troops sent to the war, 373.

*Deserters*, provost marshals to arrest, 31.

*Diplomatic Correspondence of the United States*.—With Great Britain, 379; case of the British consul at Charleston, 379; the right to obtain coal at Nassau, 379; steam gunboat Oreto, 380; proceedings relative to, 380; case of the Alabama, 381; proceedings relative to, 382; the charge of furnishing assistance to the Confederates, 383; duty to suppress them, 384; letter of Mr. Adams explaining his position, 385; belligerent rights accorded to the Confederate States, 385; case of the Emily St. Pierre, 386; treaty for the suppression of the slave trade, 387; correspondence with France, 387; anxiety for cotton, 387; condition of the manufacturing districts, 388; uniformity of policy, 388; conversation relative to mediation, 388; proposition of France to England and Russia, 389; mediation proposed by France to the United States, 389; reply of Mr. Seward, 390; correspondence with Spain, 393; reference to the treaty surrendering the right of search, 392.

*Drury's Bluff*, its position, 393; attack on, 393.

**DUPONT, Com.**, commands expeditions on Florida coast, 49.

### E

*Earth*.—Relative sunshine of different zones, 393; extent of the earth's atmosphere, 393; thickness of the earth's crust, 393; excentricity of the earth, 394; earthquake waves, 395.

*Education*.—Its diffusion in the United States, 395; primary education, 396; scholars and expense of schools in the United States, 396; secondary instruction, 396; higher education, 396; universities and colleges, 396; total expenditures in the United States, 397; object teaching, 397; origin, 398; progress, 398; Comenius, 398; Pestalozzi, 398; his views, 399; pupils and assist-

ants, 399; the system in the Canadas and the United States, 400; books published, 400; method of teaching, 401; results, 401.

*Electricity*.—Measures of electric resistance, 403; Mathieson's unit of resistance, 403; Weber's proposed absolute standard, 403; electro-motive force of voltaic piles, 403; measures of electrical quantities, 403; proposed standard of electrical resistance, 406; influence of temperature on the conducting power of metals, 404; mechanical effects of powerful tension, 404; study of the electric spark by the aid of photography, 404; production of vibrations and musical sounds by electrolysis, 405; new experiments in electro-magnetism, 405; electricity developed during evaporation and effervescence, 405; experiment with the crural nerve of a frog, 406; electrical phenomena of Vesuvius, 406; Ritchie's electrical machines, 406; conducting power of pure and alloyed copper, 407; electric lights for lighthouses, 406; Way's electric light with mercury, 409; improvement in Holmes' magneto-electric light, 409; Serrin's electric light regulator, 410; Baker's apparatus for electric light, 410; present desideratum in electric lights, 410; electric light signals, 410; application of electric light to mining purposes, 411; engraving by electricity, 411; electric despatch, 411; electric sounding apparatus, 411.

**ELLET, CHARLES, JR.**—Birth, 412; education, 412; pursuits, 412; death, 412.

*Exhibition, British Industrial*.—Results of the first opened, 412; disposal of the profits, 413; plan of that of 1862, 413; laying out of the works, 413; progress of the building, 413; the building, 414; the interior, 415; construction, 415; decoration of the building, 415; exhibition opened, 417.

Objects and articles exhibited, 418; mining, quarrying, and metallurgy, 418; chemical substances and pharmaceutical processes, 419; coal tar and lichen dyes, 420; substances used for food, 420; Indian products, 420; machinery, 421; traction engines, 421; Young's type composing machine, 423; folding, pressing, and stitching machine, 423; agricultural machines and implements, 423; civil engineering, architecture, and building contrivances, 424; models, weapons, 424; new cartridge, 425; marine engines, 425; gas engineering, 426; photography and photographic apparatus, 426; clocks and watches, 427; electric telegraphs and electrical apparatus, 427; surgical instruments and appliances, 428; sanitary appliances, 428; musical instruments, 428; miscellaneous machinery, 429; American machinery, 429; sewing machines, 431; flax and hemp, 431; silk and velvet, 432; woollen, worsted, and mixed fabrics, 432; tapestries, 433; printed and dyed fabrics, 433; lace making, 433; furs, feathers, and hair, 434; India rubber manufactures, 434; leather, including saddlery and harness, 435; paper making and stationery, 435; printing, 436; bookbinding, 436; educational works and appliances, 436; furniture and upholstery, 437; iron manufactures, 437; forged iron, 438; welding, 438; rolled iron, 438; sheet iron, 438; bars, rails, and girders, 439; armor plates, 439; Canadian iron, 439; iron in India, 439; Swedish boat plates, 440; galvanized metals, 440; Hereford screen, 440; chandeliers, gaseliers, and lamps, 441; locks and safes, 441; steel manufactures, 442; Krupp's cast steel, 442; Bessemer steel, 442; work in the precious metals, 443; aluminum articles, 443; jewelry, 443; glass, stained and fancy, 443; pottery, 445; substances used in manufactures, 445; British colonies, 445, 446, 447; Australian colonies, 447; French colonies, 449; South American States, 449; Japan, 450; China, 450; Egypt, 450; fine arts, 450; foreign paintings and sculpture, 450; review, 451.

**Fayetteville.**—Its situation, 451; population, 451; occupied by Federal troops, 451.

**FELTON, CORNELIUS C.**—Birth, 452; education, 452; pursuits, 452; writings, 452; death, 452.

**Fernandina.**—Its situation, 452; capture, 452.

**Finances of the United States.**—Condition at the close of 1861, 452; loans, 452; views of the Secretary of the Treasury, 452; drafts on the banks, 452; position of the currency, 454; public deposits, 454; the currency act, 454; its effect, 455; wants of the Treasury, 455; certificates of indebtedness, 456; regulations respecting, 456; effect of the certificates, 456; a supplemental act, 457; purchase of coin, 457; contraction of the currency, 457; public debt, 458; interest paid in specie, 458; certificates of deposit, 459; mutilation of notes, 459; rules respecting, 459; exchange of bonds for old demand notes, 459; the tax law, 460; stamp revenue in one week, 460; principle of the law, 460; details of taxes, 461; change of the tariff, 461; expansion of paper currency, 461; effects, 461; disappearance of gold and silver, 462; shinpasters, 462; postage stamps, 462; stamp currency, 462; issues of, 462; necessities of the Treasury, 463; new loan bill, 463; resources of the Treasury, 463; its operations, 463-468; advances of stocks, 464; temporary loan of the banks, 464; bids, 465; receipts and expenditures for the year ending June 30th, 465; debt, January 1st, 1863, 466; remarks of the Secretary on the loans, 466; costs of the loans, 467; investments of surplus capital, 467; number of lenders, 468; effects of currency measures upon stocks and metals, 468; prices of produce, 469; cost of imports, 469; radical changes in trade, 469; foreign measures of the value of stocks, 470; consumption of gold and silver in manufactures, 470; specie in the Northern States, 471; specie movements in New York, 471; operations of the assay office at New York, 471, 472; influence of paper money on merchandise, 472; number of failures in the Northern States in 1862, 473; advances in railway freights, 473; prices of stocks in New York during the year, 474.

**FISH, HAMILTON,** appointed commissioner to negotiate exchange of prisoners, 710.

**FITZROY, Admiral.**—His system of weather forecasts and storm signals, 575.

**Florida.**—Population, 474; census returns, 474; Federal expeditions to, 474; troops withdrawn to Richmond, 474; occupation of Jacksonville, 475; plan for the armed colonization of, 475.

**France.**—Feeling of the people, 475; improvements of the Emperor at Paris, 475; his enterprises, 476; debt of France, 476; relations with Great Britain, 476; relations on the Continent, 476; do. with Mexico, 477; do. with the United States, 477; society of St. Vincent de Paul, 477; finances of France, 477; concessions, 477; effect of the American tariff, 478; state of the manufacturing districts, 478; statistics, 478; imports, 479; railroads, 479; army and navy, 479; postal service, 479.

**Frederick.**—Its situation, 479; population, 479; occupation by Confederate troops, 479; evacuation, 479.

**Fredericksburg.**—Its situation, 479; population, 479; evacuation by Confederate troops, 479; Federal occupation and evacuation, 479; battle at, 480.

**Freedom of the Press.**—Order of the Secretary of War relative to newspaper publications, 480; second order, 480; other orders, 480; restrictions on the press considered in Congress, 480; report of the committee, 480.

**Frelinghuysen, Theodora.**—Birth, 481; education, 481; pursuits, 481; death, 481.

**FREMONT, Gen. JOHN C.,** assumes command in the Mountain Department, 102; his movements, 102; ordered to

relieve Gen. Banks, 104; his reply, 104; his march, 104; resigns his command, 126.

**Front Royal.**—Its situation, 481; attack on the 1st Maryland at, 481.

## G

**GARFIELD, Col. JOHN A.,** defeats Confederate force in Kentucky 25; his despatches, 25-26.

**Geographical and Archaeological Explorations.**—Surveys of the Mississippi and its tributaries, 481; explorations for new mines in the Territories, 481; Lower California, 482; Russian America, 482; interior of Labrador, 482; explorations of C. F. Hall, 483; Northwest Boundary Survey, 482; explorations in Mexico, 483; Central America, 483; Honduras, 483; New Granada, 483; Venezuela, 483; Ecuador, 483; Guiana, 484; Brazil, 484; Argentine Confederation, 484; Chili, 484; Patagonia, 485; geographical publications in Europe, 485; Syria, 485; Palestine, 485; Lebanon Range, 485; Northern and Central Asia, 486; Persia, 486; coasts of Japan, 486-488; China, 488-487; Island of Formosa, 487; Siam, 487; interior of Burmah, 487; Australia, 488; discoveries, 488; discoveries in Africa, 489; Barbary States, 489; White Nile, 489; Northern Africa, 490; Central Africa, 490; Western Coast, 490; Gabun, 490; Upper Guinea, 491.

Discoveries in archeology, 491; lacustrine villages in Switzerland, 491; discoveries in Egypt, 491; Algeria, 491; Tunis, 491; Syria, 492; Greece, 492; Rome, 492; France, 492.

**Georgia.**—Conscription act not enforced in northern counties, 16; population, 498; census returns, 498; destruction of the crops, 498; drafting at Savannah, 498; excitement at Savannah on the capture of Fort Pulaski, 498; abandonment of the towns, 494; conscription act, 494; opposition to it, 494; action of the Legislature and the courts, 494; message of the governor relative thereto, 494; further action of the Legislature, 495; election of Senators to the Confederate Congress, 495-496; manufacturers' association, 496; crops, 496.

**GOLDBOROUGH, REAR AD. L. M.,** commands naval part of the expedition to North Carolina, 38.

**GRANT, GEN. ULYSSES,** advances upon Fort Henry, 29; attacks Fort Donelson, 38; summons to surrender, 38; congratulates the troops, 35; commands at Shiloh, 69.

**Great Britain.**—Revenue and expenditures, 496; Parliament, 496; action relative to the Confederate States, 497; iron-clad ships, change of views relative to, 497; fortifications, 497; poor rates, 497; diplomatic intercourse, 498; operatives in Lancashire, 498; their condition, 498; effects of the supply of cotton, 499; relief, 499; external affairs, 499; financial condition, 499; imports and exports, 500; education in England, 500; postal communication, 500.

**Great Eastern Steamship,** the accident to and the repairs of, 501, 502, 503, 504, 505, 506.

**Greece.**—Area and population, 506; causes of the revolution in 1826, 506; patience of the people, 507; feelings toward the king and queen, 507; exasperation, 508; flight of the king, 508; provisional government, 508.

## H

**Habeas Corpus.**—Arrest of citizens in the United States, 508; words of the Federal Constitution, 508; order relative to prisoners who employed an attorney, 509; official statement of a case of arrest, 509; matter of arrests transferred from the state to the War Department, 509; order in relation to state prisoners, 509; commission to examine State prisoners, 510; proceedings of the commission, 510; arrest of ex-Secretary Cameron on a pro-

- cess of a court, 511; correspondence relative to threats, 511; arrest of a judge in open court in Maryland, 512; proclamation of the President suspending the writ of Habeas Corpus, 512; arrests in Philadelphia, 512; action of the District Court of the United States, 513; arrests in Vermont, 513; action of the District Court, 513; its decision, 514; arrest in New Hampshire, 514; action of the State Supreme Court, 514; action of the Supreme Court of Wisconsin, 514; opinion of the Chief Justice, 514; order to release prisoners, 516.
- HALLECK, GEN. H. W.**—Thanks to Gen. Hunter for reinforcements to Gen. Grant, 99; letter to Gen. Grant on the capture of Fort Donelson, 85; address to the invading troops, 87; his despatch announcing the occupation of Springfield, 54; do. of Arkansas, 54; do. of Fayetteville, 54; despatch on battle at Pea Ridge, 66; goes to Pittsburg Landing, 74; takes command, 74; despatches from Corinth, 75; arrives at Washington to act as general-in-chief, 124; his views on affairs, 124; letter in reply to Gen. McClellan, 125; correspondence with Gen. Lee, 714; answer to interrogatories of Secretary of War, 162.
- Harrisburg.**—Its situation, 516; population, 516.
- HOGE, THOMAS JEFF.**—Birth, 516; education, 516; writings, 516; death, 516.
- Holy Springs.**—Its situation, 516; military occupation of, 516.
- Homestead.**—Act of Congress, 5.
- HOPF, FREDERICK W.**—Birth, 516; education, 516; pursuits, 517; death, 517.
- HORN, THOMAS H.**—Birth, 517; education, 517; pursuits, 517; death, 517.
- HUNTER, DAVID,** takes command in South Carolina, 49; demands the surrender of Fort Pulaski, 49; order dividing the department, 52.
- Huntsville.**—Its situation, 517; military occupation of, 517.
- I**
- Illinois.**—Population, 518; do. of cities, 518; census statistics, 518; constitutional convention, 518; proceedings, 518; vote of the people on the Constitution, 519; political organizations, 519; resolutions of the Republican State Convention, 519; nominations by the Democratic organization, 520; votes of the people for State officers and members of Congress, 520.
- Illumination.**—Igniting point of gas and coal, 520; origin and treatment of petroleum, 520; paraffine oils, 521; carbonation of gas, 522; Bassett's carburetting apparatus, 522; illuminating gases from petroleum, coal oil, or from their derivatives, 523; gas from petroleum alone, 524; Hill's air gas, oil-water gas, and electro-chemical gas, 524; McDougal's fixed gas and atmospheric gas, 524; Elmer's pure illuminating gas, 524; air light for locomotives, 525; lampe eolienne, 526.
- Indiana.**—Population of cities, 526; census statistics, 526; financial affairs, 527; elections, 527; political organizations, 527; conventions of the democratic organization, 527; nominations, 527; resolutions, 527; convention of the republican organization, 528; nominations, 528; resolutions, 528; votes of the people, 528; provisions of the State Constitution relative to negroes, 528; troops contributed to the war, 529.
- INGERSOLL, CHARLES JARED.**—Birth, 529; education, 529; public offices, 529; death, 529.
- Insurance Companies.**—Losses, 529; do. in Massachusetts, 530; do. marine, 530; do. by fire risks, 530; increase of fire risks, 531; cases of net losses, 531; foreign companies in New York, 532; participation plan, 532; activity of life insurance, 532; companies in New York, 533; returns, 533; returns in Massachusetts, 534.
- Iowa.**—Population, 534; census statistics, 534; civil officers, 534; debt, 534; banks, 534; Legislature, 535; conventions of the political organizations, 535; nominations, 535; votes of the citizens, 535.
- Italy.**—Area and population, 535; loss of Cavour, 535; his successor, 535; obstacles, 535; action of the French emperor, 536; Ratazzi, 536; his career, 536; restoration, 536; policy, 537; movements of Garibaldi, 537; defeat at Aspromonte, 538; arrest, 538.
- J**
- JOHNSON, GEN. A. S.**—Address to his troops at Corinth, 63.
- JOHNSON, REVERDY,** sent to New Orleans to examine difficulties, 650.
- JOHNSTON, ALBERT S.**—Birth, 533; education, 533; military career, 539; death, 539.
- JOHNSTON, GEN. J. E.**—Address to the army at Manassas, 62.
- K**
- Kansas.**—Population, 539; civil officers, 539; military force, 539; Indian expedition, 539; conflicts, 539.
- KARNEY, PHILIP,** birth, 540; education, 540; military career, 540; honors, 540; death, 540.
- Kentucky.**—Census statistics, 540; political position, 540; message of the governor, 540; extra session of the Legislature called, 541; governor resigns, 541; successor, 541; report of the committee on emancipation with compensation, 541; finances, 542; military operations in the State, 542.
- KNOWLES, JAMES S.**—Birth, 543; education, 543; pursuits, 543; death, 543.
- L**
- LANDER, FREDERICK W.**—Birth, 543; education, 543; military career, 543; death, 544.
- LEE, GEN. R. E.**—Despatch of battle at Manassas, 135; answer to Gen. Pope, 136; address to the citizens of Maryland, 138; order to Gen. Hill showing what his plans were, 140.
- LINCOLN, PRESIDENT ABRAHAM.**—Order of thanks to the officers and soldiers at Mill Spring, 27; order for an advance of all the forces, 29; order of thanks on the capture of Roanoke Island, 40; order creating the Mountain Department, 90; do. Shenandoah, 90; do. Rappahannock, 90; reply to Gen. McClellan's request for reinforcements, 99; order dividing the army into corps, 84; assigning Gen. McClellan to the command, 84; letter to Gen. McClellan respecting the withdrawal of Gen. Blenker's division, 86; order to Gen. McDowell to proceed to aid Gen. Banks, 101; correspondence, 101; order to Gen. Fremont to go to the relief of Gen. Banks, 104; order forming the Army of Virginia under Gen. Pope, 126; calls three hundred thousand men, 128; his order removing Gen. McClellan, 164; message with the bill abolishing slavery in the District of Columbia, 345; message relative to the Confiscation Bill, 374; his proclamation suspending the writ of Habeas Corpus, 512; countermands the proclamation of Gen. Hunter, 725; message at the third session of the Thirty-seventh Congress, 726; emancipation proclamation, 736.
- Literature and Literary Progress in 1862.**—In the United States, 544; in Great Britain, 550.
- Louisiana.**—Census statistics, 552; educational institutions, 552; military affairs, 552; calls for troops, 552; governor's appeal, 552; call of Gen. Beauregard, 553; affairs in New Orleans before its capture, 553; address of gov. Moore to the citizens with regulations relative to Federal forces, 553; military operations in the State, 554.

*Lutherans*.—Number of members, 554; synods, 554; meeting of General Synod, 555; resolutions, 555; seminaries, 555; do. in Great Britain, 555; do. in Germany, 555; do. in France, 556; do. Sweden, 556; do. Russia, 556.

## III

*MACKENZIE*, Rt. Rev. Bishop.—Birth, 557; education, 557; pursuits, 557; death, 557.

*Maine*.—Population, 557; political organizations, 557; republican convention, 557; nominations, 557; resolutions, 557; war democrat's convention, 557; nominations, 557; resolutions, 557; democratic convention, 557; nominations, 557; resolutions, 557; votes of the citizens, 558; troops furnished, 558; passage of British troops over the territory, 558; institutions of education, 559; railroads, 559; debt, 559.

*Maryland*.—Population, 559; Legislature, 559; appropriation to families of Massachusetts soldiers killed at Baltimore, 559; message of the governor on the position of Maryland, 560; resolutions of the Legislature, 560; effect of emancipation in the District of Columbia, 560; effect of Maryland and Kentucky on the Southern side, 561; reception of Gen. Lee's army, 561; political sympathies of Maryland, 561; contribution of soldiers, 561.

*MANSFIELD*, JOSEPH K. F.—Birth, 559; military position, 559; death, 559.

*Massachusetts*.—Population, 561; increase, 561; manufactures, 561; value of property, 562; State debt, 562; protection of seaports, 562; resolutions of Legislature relative to the action of Maryland Legislature, 562; answer of Gov. Andrew to a call for more troops, 562; rally of volunteers, 562; troops contributed, 562; political organizations, 562; resolutions of the republican convention, 562; people's convention, 562; resolutions, 562, 564; democratic convention, 564; resolutions, 564; votes of the citizens, 565; refusal of the governor to receive Southern blacks into Massachusetts, 565.

*MCCLELLAN*, GEN. GEORGE B.—Force before Washington, 94; directs Western operations up to the occupation of Nashville, 99; address on taking command in the field, 84; statement at a court martial relative to the troops left at Washington, 88; instructions to Gen. Wadsworth, 88; do. to Gen. Banks, 88, 89; letter to Gen. Thomas, 89; further statements, 90; moves on Yorktown, 90; movements after its capture, 94; arrives at Williamsburg, 96; addresses to the troops, 96; address to his army at Harrison's Landing, 123; ordered to command troops at Washington, 129; his general orders, 129; order relative to the President's proclamation, 161; ordered by the President to cross the Potomac, 162; removed from command, 164; farewell to the troops, 164; retires to Trenton, 164.

*MCCULLOCH*, BEN.—Birth, 566; education, 566; military campaigns, 566.

*McDOWELL*, GEN. IRWIN, ordered to cooperate with Gen. McClellan, 101; ordered to aid Gen. Banks, 101; correspondence, 101, 102; letters to Gen. McClellan, 117, 118.

*McNAB*, SIR ALLAN N.—Birth, 566; public positions, 566; honors, 566; death, 566.

*MRADE*, WILLIAM.—Birth, 566; education, 566; pursuits, 566; death, 566.

*Memphis*.—Surrender of the city, 567; correspondence, 567; civil organization, 567; trade, 567; circulation of Confederate script forbidden, 567; newspaper suspended, 568; Union meeting, 568; families of Confederate officers sent South, 568; trade opened by Gen. Sherman, 568; vacant stores occupied, 569; operation of the partisan corps, 569; government of the city, 569; guerrillas, 567.

*Meteorology*.—Comparative temperature of the air and soil, 570; experimental researches on evaporation and absorption, 570; Dalton's theory of an independent vapor atmosphere questioned, 571; vapor of the upper atmosphere, 572; meteorological observations in balloon ascents, 572; dew bow on the surface of mud, 572; soap bubbles and the nature of cloud, 574; formation of rain near the earth, 574; Admiral Fitzroy's system of weather forecast, storm signals, &c., 575; weather signs, 578; cyclones and anti-cyclones, 579.

*Methodists*, divisions of, 579; Methodist Episcopal, 579; numbers, 579; churches, 579; conferences, 579; proceedings, 580; church South, 580; churches in British America, 581; do. South America, 581; do. Hayti, 581; do. Great Britain, 581; French Wesleyan Conference, 582; German Annual Conference, 582; Methodists in Asia, 582; do. in Africa, 582; do. in Australia, 582.

*Mexico*.—Population, 582; internal affairs, 582; movements of the French, 584; position of the Government of the United States relative to, 584.

*Michigan*.—Situation, 585; Legislature, 585; resolutions of, 585; political organizations, 585; resolutions of the democratic organization, 585; nominations, 585; republican nominations, 585; votes of the citizens, 585; troops contributed, 585; railroads in the State, 585; institutions of education, 585; salt manufactures, 586; State debt, 586; its agricultural college, 5.

*Minnesota*.—Situation, 586; character of its population, 586; civil officers, 586; troops contributed, 586; Indian war, 586; attacks on the settlers, 586; defeat of the Indians, 587; consequences of the war, 588.

*Mississippi*.—Census statistics, 588; internal affairs of the State, 588; call of the governor for troops, 589; scarcity of arms, 589; military operations in the State, 589; crops, 589.

*Missouri*.—Condition at the beginning of 1862, 589; assessments, 590; provost marshal's order to publishers, 590; oath of allegiance exacted, Chamber of Commerce, teachers and civil officers, 590; trial of bridge burners, 590; correspondence between Gens. Halleck and Price, 591; advance of Gen. Curtis's forces, 591; civil officers of the State, 591; State convention, 591; proceedings, 592; emancipation bill, 592; qualification of voters, 592; provisional government, 592; action of the convention on emancipation and compensation, 592; emancipation convention, 592; resolutions, 592; guerilla operations, 592; order of Governor Gamble, 592; operations in Calloway county, 592; attack on Independence, 594; movements in northeastern counties, 594; capture of Andrew Allman, 594; Gen. McNell's order, 594; execution of ten prisoners, 594; State election, 595; meeting of the Legislature, 595; organization, 595; State debt, 595; emancipation, 595.

*MITCHELL*, GEN. O. M.—Address to his division of troops, 86; movements toward Huntsville, 78; its capture, 78; operations in Alabama, 79; made a Major-Gen., 79; ordered to command in South Carolina, 80; birth, 585; education, 585; pursuits, 585; military services, 586; death, 586.

## IV

*Nashville*, surrender of, 87; retreat of Confederate forces, 598; surrender of the city to Federal troops, 596; state of the city, 596; Andrew Johnson appointed military governor, 597; refusal of the city officers to take the oath of allegiance, 597; resolutions of the city council, 597, condition of the city, 597; order relative to the sale of provisions, medicines, &c., 577; operations of guerrillas, 598; assessment of wealthy citizens, 598; proceedings in the city, 599.



*Navy, Confederate.*—Instructions to Capt. Bullock, 338; organization of, 599; operations of the Sumter, 599; movements of the Oreto, 599; Commander Maffit, 600; steamer Alabama, 600; movements of, 600; captures of American vessels, 600; her papers, 600; crew, 601; capture of the Virginia, 601; statement of the captain, 601; capture of the Ellaha Dunbar, 601; statement of the captain, 601; disposal of prisoners, 601; excitement in New York, 602; do. in England, 602; correspondence with the British Minister relative to losses by British subjects, 602; capture of the Ariel, 603; other captures, 603; bonded, 603; validity of, 603; appearance of the Alabama after her conflict with the Hatteras, 603; the fight, 604; officers of the Alabama, 604.

*Navy, United States.*—Its organization, 604; officers, 604; vessels, 604; squadrons, 604.

Iron-clad or armored ships, 604; necessity of armor recognized, 605; progress in its application, 605; the revolving turret or capola, 606; earliest American iron-clads, 607; the first class Monitor, 607; the Passaic, details of, 608; improvements in working the new Monitors, 609; guns discharged within the turret, 609; recoil, 609; men, 609; bed of the turret water-tight, 610; experience in battle, 610; results at Charleston, 610; loss of the original Monitor, 611; new life raft, 611; second and third class Monitors, 611; Dictator and Puritan, 611; New Ironsides, 612; Galena, 612; Roanoke, 612; Keokuk, 613; Dunderberg, 613; the Benton gunboat, 614; Essex gunboat, 614; the Tuscombina gunboat, 614; other gunboats and rams, 614; recent English and French armored vessels, 614; manufacture and application of armor plates, 615, 616; aspects of the armor question changing, 617; destructive power of projectiles, 617, 618; resistance of iron plates, 619; recent experiments with modern heavy ordnance, 620, 621; practical qualifications as to the relative efficiency of guns and armor, 622; qualities of inclined or vertical armor, 622; the question of the kind of armor and of backing, 623; extent of armor and plans of armored vessels, 624; best construction of hull for armored ships, 625; preserving the bottoms of armored vessels, 626; rams, 626; coast and harbor defences, 627; conclusions, 627.

*Navy, U. S., operations of.*—North Atlantic squadron, 629; Roanoke Island, 629; Sewall's Point, 629; batteries on the James river, 629; at New River Inlet, 629; South Atlantic squadron, 630; Little Tybee river, 630; coast of Florida, 630; steam tug Plow, 630; Stone Inlet, 630; Jacksonville, 630; Gulf squadron, 630; Appalachicola, 630; St. Andrew, 630; Cedar Keys, 631; mouths of the Mississippi, 631; preparations to attack Forts Jackson and Philip, 631; attack commenced, 631; plan of the attack, 632; bombardment, 633; preparations to pass the forts, 633; passing of the forts, 634; conflict, 634; approach to New Orleans, 635; correspondence with the city authorities, 635, 636; operations of Com. Farragut above New Orleans, 637; operations of Com. Porter upon the forts, 637; their surrender, 638; Baton Rouge, 638; Natchez, 638; Vicksburg, 638; Confederate ram Arkansas, 639; further movements before Baton Rouge, 639; Western flotilla, 640; Potomac flotilla, 640; James river flotilla, 640.

*NELSON, WILLIAM.*—Birth, 640; education, 640; naval life, 640; transferred to a military command, 640; death, 640.

*NESSELRODE, KARL ROBERT VON.*—Birth, 641; education, 641; pursuits, 641; public employments, 641; death, 641.

*New Hampshire.*—Increase of population, 641; civil officers, 641; political organizations, 641; resolutions, 641; votes of the citizens, 642; resolutions of the Legislature, 642; troops contributed, 642; finances, 642; railroads, 642; institutions of education, 642.

*New Jersey.*—Population of cities, 642; political excitement, 642; political organizations, 642; republican convention, 642; nominations, 642; resolutions, 643; democratic convention, 643; nominations, 643; resolutions, 643; votes of the citizens, 643; troops furnished, 644; services, 644; State debt, 645; institutions of education, 645.

*New Orleans.*—Occupation by Gen. Butler, 645; proclamation of Gen. Butler, 645; the press, 645; landing of troops, 646; aspect of the city, 646; providing relief for the poor, 646; distribution of Confederate stores captured, 647; seizure of specie, 647; proclamation relative to females, 647; excitement, 647; apology of the mayor, 648; explanation of Gen. Butler, 648; his private letter, 648; result of one month, 648; execution of Mumford, 649; revengeful feeling excited, 649; explanation of Gen. Butler, 649; difficulties with the consuls, 649; action of Beverdy Johnson, 650; further difficulties, 650; correspondence, 651; emancipation order, 651; confiscations, 651; oath of allegiance renewed, 652; excitement, 652; further orders, 652; command transferred to Gen. Banks, 652; farewell address of Gen. Butler, 652-3; proclamation of Gen. Banks, 653.

*New York.*—Political aspect of the State, 654; political organization, 655; democratic convention, 655; nominations, 655; resolutions, 655; republican convention, 655; nominations, 655; resolutions, 655; votes of the citizens, 656; finances of the State, 656; operations of the canal department, 656; premium for specie to pay State interest, 656; canal debt, 657; banks of the State, 657; Federal stocks held, 657; railroads, 657; salt manufacture, 658; troops contributed, 658; militia law, 658; charter election in New York city, 659; operations of city railroads, 659; institutions of education, 660.

*North Carolina.*—Appeal of the governor for clothes and shoes for troops, 15; advance of Gen. Burnside's expedition against, 39; address of Gen. Clark, 41; population, 660; approach of Gen. Burnside's forces, 660; conscription, how received, 660; State convention, 660; State election, 660; candidates, 661; difference of parties, 661; result, 661; resolutions of the Legislature, 661; troops taken by conscription, 661; conference with provisional governor Stanley refused, 662.

## O

*Obituaries,* American, 662; do. foreign, 663.

*Ohio.*—Civil officers, 665; political organizations, 665; democratic convention, 665; nominations, 665; resolutions, 665; republican convention, 666; nominations, 666; resolutions, 667; votes of the citizens, 667; resolutions of the Legislature, 667; apprehension of an attack upon Cincinnati, 667; troops contributed, 667; charitable institutions, 667; institutions of education, 667; finances, 668; State debt, 668; railroads, 668.

*Oregon.*—Its situation, 668; population, 668; civil officers, 668; Legislature, 668; taxes, 668; colleges, 668; climate, 668.

## P

*PASQUIER, ETIENNE D.*—Birth, 668; education, 668; pursuits, 668; public services, 668; death, 668.

*Patents.*—Business of the patent office, 669; costs to patentees, 669; patents of 1863, 669; beer cooling, 669; ballast boxes, 669; canteens, 700; dredging machines, 700; firearms and implements of war, 700; accelerating projectiles, 700; revolving chambered pistols, 701; revolving guns, 701; hay elevator, 701; lamps, 701; locomotives, 701; locomotive tracks, 701; machine for planing wood mouldings, 702; shoes, 702; skeleton skirts, 702; sewing machines, 702.

*Pennsylvania*.—Population, 706; civil officers, 706; political organizations, 708; democratic convention, 703; nominations, 706; resolutions, 708; republican convention, 704; nominations, 704; resolutions, 704; votes of the citizens, 705; financial condition of the State, 705; tax, 706; interest on public debt, 706; troops contributed, 706; volunteers called to resist invasion, 706; capture of Chambersburg, 706; voting of absent soldiers, 706; banks, 706; railroads, 706; institutions of education, 707; charitable institutions, 707; mineral wealth, 707.

*Pensions* law passed by Congress, 795.

*Pera*, Gen.—Movement toward New Madrid, 61; its capture, 61; crosses the Mississippi, 63; surrender of the enemy, 68; ordered to Corinth, 65; address to the army of Virginia, 126; his orders, 127; correspondence with Gen. Lee, 136.

*Presbyterians*, divisions of, 707; membership—Old School, 707; church South, 707; Cumberland, do., 707; General Assembly, 707; New School, do., 708; views on slavery, 708; effects of the war, 708; other portions, 708; churches in the British provinces, 709; Scotland, 709; England, 709; Ireland, 709; Australia, 710; New Zealand, 710.

*PRICE, STELLING A.*, Gen.—His withdrawal from Missouri, 54.

*Prisoners, Exchange of*.—Position at the close of 1861, 710; commissioners to Richmond appointed, 710; admission to Richmond refused, 710; arrangements for an exchange, 711; recommendation to release Confederate prisoners from the obligations of parole, 711; exchange suspended, 711; privateersmen, 711; held as prisoners of war, 711; exchange proposed, 712; correspondence, 712; instructions of Confederate Secretary, 712; exchange suspended, 713; Federal Government yields, 713; terms of exchange established, 713-714; new complications, 714; correspondence of Gens. Lee and Halleck, 714; orders to military commanders in Virginia, 715; letter of President Davis to Gen. Lee, 716; letter of Gen. Lee to Gen. Halleck, 716; Confederate order relative to Gens. Hunter and Phelps, 717; do. relative to Gen. Nell, 717.

*Projectiles*, destructive power of, 617.

*Protestant Episcopal Church*.—First council in the Confederate States, 496.

*Protestant Episcopal Church*, division in, 717, 718; church in Confederate States, 718; General Convention, 718; pastoral letter, 718; church in the British provinces, 718; church of England, 719; outside of England, 719; in Asia, 719; British possessions in Africa, 719; in Oceania, 719; in Sandwich Islands, 719.

*Public Documents*.—Message of President Lincoln to Congress on the emancipation of slaves and compensation to the owners, 720; proclamation countermanding the order of Gen. Hunter relative to slaves, 720; message of President Lincoln to Congress on emancipation with compensation, 720; appeal to the Border State members of Congress in behalf of emancipation with compensation, 721; reply of a majority of the members, 722, 723; reply of the minority, 724; reply of Mr. Maynard of Tennessee, 725; proclamation of President Lincoln relative to future emancipation of slaves, 725; message of President Lincoln at the third session of the Thirty-seventh Congress, 730; inaugural address of Jefferson Davis, 732; do. message at the first session of the Confederate Congress, 734; do. message at the second session of the Confederate Congress, 734; emancipation proclamation of President Lincoln, 736; retaliatory proclamation of Jefferson Davis, 737; overtures of France and the replies of Great Britain and Russia on mediation in the affairs of the United States, 738; treaty between the United States and Great Britain for the suppression of the African slave trade, 741.

## R

*Reformed Churches*.—What the name designates, 743; Dutch Reformed Church, 773; German Reformed Church, 743; Reformed churches of Europe, 744.

*Rhode Island*.—Population, 744; political organizations in the State, 745; democratic convention, 745; nominations, 745; resolutions, 745; votes of the citizens, 745; debt of the State, 746; banking capital, 746; railroads, 746; schools, 746; troops furnished, 746; order for a negro regiment, 746.

*RICHARDSON, ISRAEL B.*—Birth, 746; education, 746; rank in the army, 746; death, 746.

*Roman Catholic Church*, population under, 746; other statistics, 746; increase, 747; present number, 747; great council at Rome, 747; temporal power of the Pope, 748; progress of the Church in Asia, 748.

*ROSCRANS, GEN.*—Address to the troops after the battle at Corinth, 154.

*ROSE, JAMES CLARK*.—Birth, 749; naval service, 749; death, 749.

*Russia*.—Population, relations with Poland, 749; emancipation of serfs, 750; feelings in Russia, 750; excitement produced by the proposed radical changes, 750; action of the Government, 751; decree of the Emperor, 751.

## S

*SAN MIGUEL, Evaristo*.—Birth, 750; education, 750; liberal views, 750; official positions, 751; death, 752.

*SAULSBURY, WILLARD*, Senator from Delaware, offers resolutions proposing a conference for the settlement of difficulties, 276.

*STANTON, EDWIN M.*, appointed Secretary of War, 53; order to Gen. McDowell how to proceed after junction with Gen. Shields, 101; call for troops to defend Washington, 107; order to take military possession of the railroads, 108; order relieving Gen. Fremont from command, 126; orders to military commanders in Virginia, 715.

*SEWARD, W. H.*, Secretary of State.—Reply to a resolution of Congress relative to passports for California, 294; reply to the French proposition for mediation, 290.

*Slaves*.—Questions raised, 752; is the negro a citizen? 752; opinion of Attorney General Bates, 752; his position in Massachusetts, 752; proceedings in Illinois, 752; fine for bringing negroes into the State, 753; instructions from the Navy Department, 753; proceedings of a Kansas regiment, 753; proceedings in Chicago, 753; do. in Brooklyn, 754; social position described in Congress, 754; instructions to the marshal of the District of Columbia relative to slaves, 754; order of Gen. Halleck, 754; do. of Gen. Curtis, 754; do. of Gen. Hunter, 754; do. of Gen. Williams, 754; proceedings in North Carolina, 754; instructions of Secretary Cameron relative to the employing slaves, 755; further orders, 755; social experiment with the negroes, 756; education, 756; field work, 756; order of Gen. Saxton relative to the morals of the negroes, 757; organization as soldiers, 757; letter of Gen. Hunter in answer to a resolution of Congress, 757; orders of Gen. Lane, 758; colonization, 758; removal to the New England States proposed, 758.

*SMITH, CHAS F.*—Birth, 758; military services, 758; death, 795.

*South Carolina*.—Population, 759; State convention, 759; command of the sea coast, 759; troops refuse to go out of the State, 759; crops, 759; troops furnished to the Confederate army, 760; failure of the stone blockade, 760.

*STEVENS, ISAAC I.*—Birth, 760; military rank, 760; civil offices, 760; military command, 760.

*SUMNER, JOHN B.*—Birth, 760; education, 760; pursuits, 760; writings, 760; death, 760.

## T

- Tai-ping Rebellion*.—Historical sketch, 761; the leader, 761; his life, 761; religious vagaries, 769; military exploits, 762; changes in the Government of China, 762; results, 763.
- Tennessee*.—Population, 768; address of Gov. Harris, 768; order of Gen. Grant, 768; appointment of Gov. Johnson, 768; his appeal to the people, 768; city council of Nashville required to take the oath of allegiance, 764; letter to the governor from Confederate officers, 765; trade, 765; cotton traffic, 765; Union Committee organization, 765; confiscation enforced, 766; Union meetings, 766; imprisonment of clergymen, 766; guerilla operations, 767, 768, 769.
- Territories of the United States*.—Organization, 769; Nebraska, 769; Dakota, 769; Idaho, 770; Washington, 770; Nevada, 770; silver mining, 770; Utah, 771; Colorado, 771; Indian Territory, 771; New Mexico, 772; military operations in, 772.
- Texas*.—Population, 778; crops, 778; affairs in, 778; occupation of Galveston, 778; its subsequent capture, 774.
- THOMAS, GEN. GEO. H., attacks Gen. Zollicoffer, 27.
- TRUMBULL, LYMAN, Senator, on the Federal force before Fort Donelson, 82.
- TYLER, JOHN—Birth, 775; education, 775; public offices, 775; death, 775; character, 775.

## U

- UHLAND, JOHANN LUDWIG.—Birth, 776; education, 776; writings, 776; death, 776.
- United States*.—Census statistics of 1860, 777-788; views of the people on the subject of slavery, 784, 787; growth of the anti-slavery sentiment, 787; denunciations on both sides, 787; third party success, 787; anti slavery almost successful in 1856, 787; successful in 1860, secession commenced, 787; silence of the incoming administration, 787; position of President Lincoln at the close of 1861 on the subject of slavery, 788; action of Congress, 788; message relative to emancipation with compensation, 788; views of the people relative to the proposition, 788; explanation of his views, 789; further remarks relative to the bill for emancipation in the District of Columbia, 789; proclamation countermanding the order of Gen. Hunter, 789; views of the people, 789; conference of the President with the Border State members, 790; answers of the members, 790; cause of the bitterness of the war, 790; failure of emancipation with compensation, 791; address of the Governors to the President relative to calling more troops, 791; his reply, 791; charges made against President Lincoln, 791; his reply, 792; reception of his reply by the people, 792; the watchword now of the friends of emancipation, 792; military necessity, 792; conference of the President with a deputation from Chicago, 792; issues his proclamation of prospective emancipation, 793; how received, 793; address of the Governors at Altoona, 793; whom signed by, 794; was it a military necessity? 794; argument of the Secretary of War to show the military necessity, 794; emancipation proclamation issued, 794; the consummation of anti-slavery, 795; appropriations by Congress, 795; tax laws in Southern States, 795; pension law, 795; treaty with England on the slave trade, 796; execution of Nathaniel Gordon for

engaging in the slave trade, 796; state of affairs at the close of the year, 796.

- VAN BUREN, MARTIN.—Birth, 796; public services, 796; character, 797; death, 797.
- Vermont*.—Population, 797; political organizations, 797; republican convention, 797; nominations, 797; resolutions, 797; democratic convention, 797; nominations, 797; resolutions, 797; vote of the citizens, 797; message of the governor, 797; finances, 797; troops contributed, 797; institutions of education, 797.
- Virginia*.—Population, 798; causes of secession, 798; election of Senators, 798; enrolment of negroes, 798; message of the governor on the successes of Federal troops, 798; importance of Richmond, 798; distillation of whiskey prohibited, 798; licenses to traders, 798; proclamation of the governor relative to the defence of Richmond, 799; resolution relative to partisan rangers, 799; loss of slave property, 799; principle of emancipation, 799; extra session of the Legislature, 800; resolution relative to President Lincoln's emancipation proclamation, 800; governor refuses to allow conscripts to be taken from the militia camps, 800.
- Virginia, Western*.—Proceedings in, 800; popular convention, 801; formation of a State Government Constitutional Convention, 801; act of Congress for the admission of Western Virginia, 801; population of, 802; civil officers, 802.
- WAKLEY, THOMAS.—Birth, 802; education, 802; publishes the *London Lancet*, 802; civil offices, 802; death, 802.

## W

- Water Works*.—At Boston, 808; cost, 808; supply of water, 808; water works at Brooklyn, 808; sources of supply, 808; main conduit, 808; pumping engines, 804; their operation, 805; reservoirs, 806; Cincinnati water works, 807; consumption, 807; changes, 807; Detroit water works, 807; wood distribution pipes, 807; New Haven water works, 807; source of supply, 807; reservoir, 808; distributing main, 808; New York water works, 808; High Bridge improvement, 808; Manhattan valley improvement, 809; new reservoir, 809; interest of Croton debt, 811; Croton water rent, 811; Philadelphia water works, 811; Fairmount works, 811; Spring Garden works, 811; Kensington works, 811; Twenty-fourth Ward works, 812.
- Webb's Cross Roads*, battle of, 29.
- WELLES, GIDEON, Secretary of Navy.—Letter of thanks to Com. Foote for the capture of Fort Henry, 81.
- WILSON, HENRY, Senator.—Statement respecting the retention of Gen. McDowell's corps, 87.
- WILSON, Lieut. J. H.—Explorations of Wall's Cut, Ga., 46.
- WINDISCHGRATZ, ALFRED ZU, Prince.—Public services, 812; death, 812.
- Wisconsin*.—Population, 812; Legislature, 812; resolutions, 812; personal liberty bills, 812; death of the governor, 812; election of members of Congress, 812; State debt, 812; banks, 812; railroads, 812; institutions of education, 812; troops contributed, 812.
- WOLFF, JOSEPH.—Birth, 812; education, 812; studies, 812; travels, 812; studies in England, 814; marriage, 814; perils in Asia, 814; visits the United States, 814; ordained deacon, 814; travels, 814; death, 814.
- ZOLLIFFER, Gen., defeated in Kentucky, 27.

## Z













ID:000020097219  
031Am35 v.2 1862  
The American annual  
route to: CATO-PARK  
in transit to:  
UP-ANNEX

1/8/2007, 7:48



**D. A. BULEN**  
301 RANDOLPH STREET  
MEADVILLE, PA.

Specializing on  
The War Between  
the States

